

Introduction

The VXR-9000 has been aligned at the factory for the specified performance across the entire frequency range specified. Realignment should therefore not be necessary except in the event of a component failure. All component replacement and service should be performed only by an authorized Vertex Standard representative, or the warranty policy may be voided.

The following procedures cover the sometimes critical and tedious adjustments that are not normally required once the transceiver has left the factory. However, if damage occurs and some parts are replaced, realignment may be required. If a sudden problem occurs during normal operation, it is likely due to component failure; realignment should not be done until after the faulty component has been replaced.

We recommend that servicing be performed only by authorized Vertex Standard service technicians who are experienced with the circuitry and fully equipped for repair and alignment. Therefore, if a fault is suspected, contact the dealer from whom the transceiver was purchased for instructions regarding repair. Authorized Vertex Standard service technicians realign all circuits and make complete performance checks to ensure compliance with factory specifications after replacing any faulty components. Those who do undertake any of the following alignments are cautioned to proceed at their own risk. Problems caused by unauthorized attempts at realignment are not covered by the warranty policy. Also, Vertex Standard must reserve the right to change circuits and alignment procedures in the interest of improved performance, without notifying owners. Under no circumstances should any alignment be attempted unless the normal function and operation of the transceiver are clearly understood, the cause of the malfunction has been clearly pinpointed and any faulty components replaced, and the need for realignment determined to be absolutely necessary. The following test equipment (and thorough familiarity with its correct use) is necessary for complete realignment. Correction of problems caused by misalignment resulting from use of improper test equipment is not covered under the warranty policy. While most steps do not require all of the equipment listed, the interactions of some adjustments may require that more complex adjustments be performed afterwards. Do not attempt to perform only a single step unless it is clearly isolated electrically from all other steps. Have all test equipment ready before beginning, and follow all of the steps in a section in the order presented.

Required Test Equipment

- RF Signal Generator with calibrated output level at 1 GHz
- AF Signal Generator
- Frequency Counter: ± 0.2 ppm accuracy at 1 GHz
- In-line Wattmeter with 5% accuracy at 1 GHz
- 50-ohm, 50-W RF Dummy Load
- Regulated DC Power Supply (standard 13.6V DC, 15A)
- AC Voltmeter
- DC Voltmeter
- UHF Sampling Coupler
- Microsoft® Windows® 98 or later operating system
- Vertex Standard VPL-1 Connection Cable and CE60 Alignment program

Alignment Preparation & Precautions

A 50-ohm RF Dummy load and in-line wattmeter must be connected to the main antenna jack in all procedures that call for transmission, except where specified otherwise. Correct alignment is not possible with an antenna.

After completing one step, read the following step to determine whether the same test equipment will be required. If not, remove the test equipment (except dummy load and wattmeter, if connected) before proceeding.

Correct alignment requires that the ambient temperature be the same as that of the transceiver and test equipment, and that this temperature be held constant between 20 °C and 30 °C (68 °F ~ 86 °F). When the transceiver is brought into the shop from hot or cold air, it should be allowed time to come to room temperature before alignment.

Whenever possible, alignments should be made with oscillator shields and circuit boards firmly affixed in place. Also, the test equipment must be thoroughly warmed up before beginning.

Note: Signal levels in dB referred to in this procedure are based on 0 dB μ EMF = 1.0 μ V.

Test Setup

Setup the test equipment as shown below, apply 13.6V DC power to the **VXR-9000**.

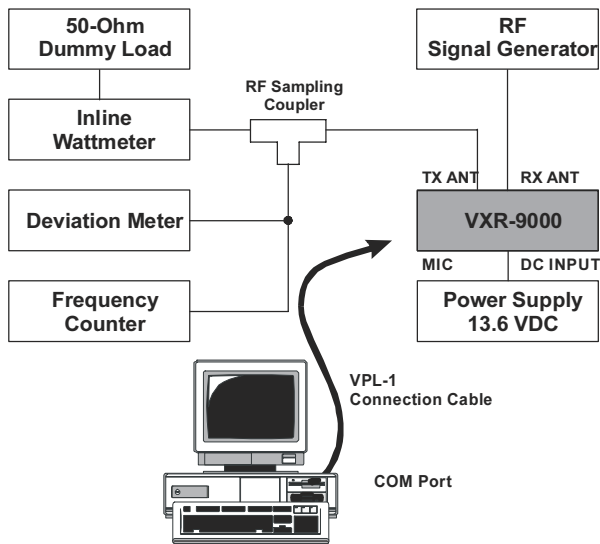

The **VXR-9000** must be programmed for use in the intended system before alignment is attempted. The RF parameters are loaded from the file during the alignment process.

In order to facilitate alignment over the complete switching range of the equipment it is recommended that the channel data in the transceiver is preset as the chart below.

| CHANNELS | FREQUENCY (SIMPLEX) |
|-----------|---------------------|
| Band-LOW | |
| Band-MID | |
| Band-HIGH | |

The alignment mode is accessed by "Alignment mode" command from the computer whilst switching on. And the alignment tool operates it automatically.

During the alignment mode, normal operation is suspended. Use the alignment tool program running on PC.

The Alignment Tool Outline

Installation the tool

Install the CE60 (Clone Editor) to your PC.

The re-alignment for **VXR-9000** may use the "Alignment" menu of CE60.

Basic sequence

The data displayed in screen of this tool is temporary data, and there is fear that the consistence of the displayed data and the data in the transceiver is failure when you do not keep the sequence which is specified below.

1. Enter the alignment mode
2. Data upload
3. Align data
4. Data download

When finish the alignment one parameter, the tool ask you "Update this data?" If you select "Yes," the temporary data is updated. If you select "Yes," the tool downloaded data to the transceiver.

Menu of the Tool (BASIC ALIGNMENT)

In the Basic Alignment mode, the aligned data written in the radio will be able to re-align its alignment data. In this mode, there are many items to align with three point (low edge, center and high edge) except "VCO," "RX Tune" and "Mod Balance." The value of each parameter can be changed to desired position by "←" / "→" arrow key for up/down, direct number input and drag the mouse.

To enter the Basic Alignment Mode, select "Basic Alignment" in the main menu "Radio." It will start to "Upload" the written personalized data from the radio and to "Download" alignment data to the radio. Then pressing the button "OK" will start the Basic Alignment Mode.

Note; when all items are aligned, it is strongly recommended to align according to following order. The detail information is written in the help of CE60 (Clone Editor).

1. RX VCO Tune Voltage (RX VCO)
2. TX VCO Tune Voltage (TX VCO)
3. PLL Reference Frequency (Frequency)
4. RX Sensitivity (RX Tune)
5. Squelch (SQL)
6. TX Power
7. Modulation Balance <Wide>
8. Modulation Balance <Narrow>
9. Maximum Deviation <Wide>
10. Maximum Deviation <Narrow>
11. Sub-Audio (CTCSS/DCS) Deviation