

***FCC Part 15***  
***EMI TEST REPORT***  
  
*of*

E.U.T. : WIRELESS RF SMOKE  
DETECTOR

FCC ID. : K4ESHSDT-1

MODEL : SHSDT-1

Working Frequency : 315MHz

*for*

APPLICANT : SUPERIOR ELECTRONICS CORPORATION  
ADDRESS : NO. 10, LANE 31, CHUNGTEH ST., TAIPEI,  
TAIWAN, R.O.C.

Test Performed by

**ELECTRONICS TESTING CENTER, TAIWAN**  
NO. 34, LIN 5, DING FU TSUN, LINKOU HSIANG  
TAIPEI HSIEN, TAIWAN, R.O.C.  
Tel : (02)26023052 Fax : (02)26010910  
<http://www.etc.org.tw> ; e-mail: [etcemi@seed.net.tw](mailto:etcemi@seed.net.tw)

Report Number : ET93R-12-055

## TEST REPORT CERTIFICATION

Applicant : SUPERIOR ELECTRONICS CORPORATION RHINE  
NO. 10, LANE 31, CHUNGTEH ST., TAIPEI, TAIWAN, R.O.C.

Manufacturer : SUPERIOR ELECTRONICS CORPORATION RHINE  
NO. 10, LANE 31, CHUNGTEH ST., TAIPEI, TAIWAN, R.O.C.

Description of EUT :

a) Type of EUT : WIRELESS RF SMOKE DETECTOR  
b) Trade Name : SECO-LARM  
c) Model No. : SHSDT-1  
d) FCC ID : K4ESHSDT-1  
e) Working Frequency : 315MHz  
f) Power Supply : DC 9V Battery

Regulation Applied : FCC Rules and Regulations Part 15 Subpart C (2003)

I HEREBY CERTIFY THAT; The data shown in this report were made in accordance with the procedures given in ANSI C63.4 and the energy emitted by the device was founded to be within the limits applicable. I assume full responsibility for accuracy and completeness of these data.

Note : 1. The results of the testing report relate only to the items tested.  
2. The testing report shall not be reproduced except in full, without the written approval of ETC.

Issued Date : Dec. 20, 2004

Test Engineer : Tien Lu Liao  
( Tien Lu Liao )

Approve & Authorized Signer : Will Yauo  
Will Yauo, Manager  
EMC Dept. II of ELECTRONICS  
TESTING CENTER, TAIWAN

# Table of Contents

Page

<b>1. GENERAL INFORMATION.....</b>	<b>1</b>
1.1 PRODUCT DESCRIPTION .....	1
1.2 CHARACTERISTICS OF DEVICE:.....	1
1.3 TEST METHODOLOGY .....	1
1.4 TEST FACILITY.....	1
<b>2. DEFINITION AND LIMITS .....</b>	<b>2</b>
2.1 DEFINITION.....	2
2.2 RESTRICTED BANDS OF OPERATION.....	2
2.3 LIMITATION.....	2
2.4 LABELING REQUIREMENT .....	4
2.5 USER INFORMATION.....	4
<b>3 SYSTEM TEST CONFIGURATION .....</b>	<b>5</b>
3.1 JUSTIFICATION .....	5
3.2 DEVICES FOR TESTED SYSTEM.....	5
<b>4. RADIATED EMISSION MEASUREMENT .....</b>	<b>6</b>
4.1 APPLICABLE STANDARD .....	6
4.2 MEASUREMENT PROCEDURE.....	6
4.3 TEST DATA .....	8
4.4 FIELD STRENGTH CALCULATION.....	10
4.5 ACTIVATE TIME .....	10
4.6 CALCULATION OF DUTY FACTOR.....	10
4.7 RADIATED TEST EQUIPMENT .....	15
4.8 MEASURING INSTRUMENT SETUP .....	15
4.9 RADIATED MEASUREMENT PHOTOS.....	16
<b>5. BANDWIDTH OF EMISSION.....</b>	<b>17</b>
5.1 APPLICABLE STANDARD PLOT GRAPHIC OF BANDWIDTH.....	17
5.2 BANDWIDTH TEST EQUIPMENT .....	17
5.3 PLOT GRAPHIC OF BANDWIDTH.....	17
<b>6. CONDUCTED EMISSION MEASUREMENT.....</b>	<b>19</b>
6.1 DESCRIPTION.....	19
<b>7 ANTENNA REQUIREMENT.....</b>	<b>20</b>
7.1 STANDARD APPLICABLE .....	20
7.2 ANTENNA CONSTRUCTION.....	20

# 1. GENERAL INFORMATION

## 1.1 Product Description

The SHSDT-1 is an advanced smoke detector with wireless RF transmission capability specifically designed as an accessory smoke detector that can be integrated with the NeighborLink-1 system.

Basically the smoke detector is designed to sense smoke that comes into the detector chamber. It does not sense gas, heat, or flame. This smoke detector is designed to give early warning of developing fires by giving off the alarm sounds from its built-in alarm horn, and if integrated with NeighborLink-1 system, it will simultaneously activate the NeighborLink-1 system as well. It can provide precious time for you and your family to escape before a fire spreads. However, the smoke detector makes such pre-warning of fire accident possible, only if the detector is located, installed, and maintained properly as described in this Owners Manual.

## 1.2 Characteristics of Device:

- Operates on 9-volt battery
- Equipped with a loud 85 decibel (at 10 ft.) alarm
- Equipped with a wireless RF transmitter that uses 315MHz radio band for transmission.
- Red LED indicator light flashes once every 45 seconds during operation (in ready mode).

## 1.3 Test Methodology

Both conducted and radiated testing were performed according to the procedures in chapter 13 of ANSI C63.4.

The Transmitter under test was operated continuously in its normal operating mode for the purpose of the measurements. In order to secure the continuous operation of the device under test, rewiring in the circuit was done by the manufacturer so as to affect its intended operation. The receiving antenna polarized horizontally was varied from 1 to 4 meters and the wooden turntable was rotated through 360 degrees to obtain the highest reading on the field strength meter or on the display of the spectrum analyzer. And also, each emission was to be maximized by changing the orientation of the Transmitter under test.

In order to determining the average value during one pulse train of the radiated power generated from the Transmitter under test, the encoded wave form in the time domain was used.

## 1.4 Test Facility

The open area test site and conducted measurement facility used to collect the radiated data is located on the roof top of Building at No.34, Lin 5, Ding Fu Tsun, Linkou Hsiang, Taipei Hsien, Taiwan, R.O.C.

This site has been fully described in a report submitted to your office, and accepted in a letter dated Feb. 10, 2000.

## 2. DEFINITION AND LIMITS

### 2.1 Definition

Intentional radiator:

A device that intentionally generates and emits radio frequency energy by radiation or induction.

### 2.2 Restricted Bands of Operation

Only spurious emissions are permitted in any of the frequency bands listed below:

MHz	MHz	MHz	GHz
0.090 - 0.110	16.42-16.423	399.9-410	4.5-5.15
0.495 - 0.505 **	16.69475 - 16.69525	608-614	5.35-5.46
2.1735 - 2.1905	16.80425 - 16.80475	960-1240	7.25-7.75
4.125-4.128	25.5-25.67	1300-1427	8.025-8.5
4.17725-4.17775	37.5-38.25	1435-1626.5	9.0-9.2
4.20725-4.20775	73-74.6	1645.5-1646.5	9.3-9.5
6.215-6.218	74.8-75.2	1660-1710	10.6-12.7
6.26775-6.26825	108-121.94	1718.8-1722.2	13.25-13.4
6.31175-6.31225	123-138	2200-2300	14.47-14.5
8.291-8.294	149.9-150.05	2310-2390	15.35-16.2
8.362-8.366	156.52475 - 156.52525	2483.5-2500	17.7-21.4
8.37625-8.38675	156.7-156.9	2655-2900	22.01-23.12
8.41425-8.41475	162.0125-167.17	3260-3267	23.6-24.0
12.29-12.293	167.72-173.2	3332-3339	31.2-31.8
12.51975-12.52025	240-285	3345.8-3358	36.43-36.5
12.57675-12.57725	322-335.4	3360-4400	Above 38.6
13.36-13.41			

Remark “\*\*”: Until February 1, 1999, this restricted band shall be 0.490-0.510 MHz

### 2.3 Limitation

#### (1) Conducted Emission Limits:

Except as shown in paragraphs (b) and (c) of this section, for an intentional radiator that is designed to be connected to the public utility (AC) power line, the radio frequency voltage that is conducted back onto the AC power line on any frequency or frequencies within the band 150kHz to 30 MHz shall not exceed the limits in the following table, as measured using a 50 $\mu$ H/50 ohms line impedance stabilization network (LISN). Compliance with the provisions of this paragraph shall be based on the measurement of the radio frequency voltage between each power line and ground at the power terminal. The lower limit applies at the boundary between the frequency ranges.

Frequency MHz	Quasi Peak dB $\mu$ V	Average dB $\mu$ V
0.15 - 0.5	66-56*	56-46*
0.5 - 5.0	56	46
5.0 - 30.0	60	50

- Decreases with the logarithm of the frequency

**(2) Radiated Emission Limits :**

According to 15.231, Periodic operation in the band 40.66-40.70 MHz and above 70 MHz, the field strength of emissions from intentional radiators operated under this section shall not exceed the following:

Frequency Band (MHz)	Field strength of Fundamental (uV/m)	Field strength of Spurious (uV/m)
40.66-40.70	2250	225
70-130	1250	125
130-174	*1,250 to 3,750	*125 to 375
174-260	3750	375
260-470	*3,750 to 12,500	*375 to 1250
Above 470	12500	1250

\* Linear interpolations.

Field strength limits are at the distance of 3 meters, emissions radiated outside of the specified bands, shall be according to the general radiated limits in 15.209, as following table:

Other Frequencies (MHz)	Field Strength of Fundamental	
	$\mu$ V/meter	dB $\mu$ V/meter
30 - 88	100	40.0
88 - 216	150	43.5
216 - 960	200	46.0
Above 960	500	54.0

As shown in 15.35(b), for frequencies above 1000MHz, the field strength limits are based on average detector, however, the peak field strength of any emission shall not exceed the maximum permitted average limits, specified above by more than 20 dB under any condition of modulation.

**B.**

According to 15.109, Except for Class A digital devices, the field strength of radiated emissions from unintentional radiators at a distance of 3 meters shall not exceed the following values:

**Class B Radiated Emission Limits :**

Frequency MHz	Distance Meters	Radiated dB $\mu$ V/m	Radiated $\mu$ V/m
30 - 88	3	40.0	100
88 - 216	3	43.5	150
216 - 960	3	46.0	200
above 960	3	54.0	500

### **(3) Limit of transmission time**

- a) A manually operated Transmitter shall employ a switch that will automatically deactivate the Transmitter (Transmitter) within not more than 5 seconds of being released.
- b) A Transmitter activated automatically shall cease transmission within 5 seconds after activation.

## **2.4 Labeling Requirement**

The device shall bear the following statement in a conspicuous location on the device :

This device complies with part 15 of the FCC Rules. Operation is subject to the following two conditions: (1) This device may not cause harmful interference, and (2) this device must accept any interference received, including interference that may cause undesired operation.

## **2.5 User Information**

The users manual or instruction manual for an intentional or unintentional radiator shall caution the user that changes or modifications not expressly approved by the party responsible for compliance could void the user's authority to operate the equipment.

### 3 SYSTEM TEST CONFIGURATION

#### 3.1 Justification

All measurement were intentional to maximum the emissions from EUT by varying the connection cables, therefore, the test result is sure to meet the applicable requirement.

#### 3.2 Devices for Tested System

Device	Manufacture	Model / FCC ID.	Description
WIRELESS RF SMOKE DETECTOR*	SUPERIOR ELECTRONICS CORPORATION	SHSDT-1 K4ESHSDT-1	----

Remark “\*” means equipment under test.



## 4. RADIATED EMISSION MEASUREMENT

### 4.1 Applicable Standard

For periodic operation intentional radiator, the radiated emission shall comply with 15.231(b).

### 4.2 Measurement Procedure

1. Setup the configuration per figure 5 and 6 for frequencies measured below and above 1 GHz respectively.
2. For emission frequencies measured below 1 GHz, a pre-scan is performed in a shielded chamber to determine the accurate frequencies of higher emissions will be checked on a open test site. As the same purpose, for emission frequencies measured above 1 GHz, a pre-scan also be performed with a 1 meter measuring distance before final test.
3. For emission frequencies measured below and above 1 GHz, set the spectrum analyzer on a 100 kHz and 1 MHz resolution bandwidth respectively for each frequency measured in step 2.
4. The search antenna is to be raised and lowered over a range from 1 to 4 meters in horizontally polarized orientation. Position the highness when the highest value is indicated on spectrum analyzer, then change the orientation of EUT on test table over a range from 0° to 360° with a speed as slow as possible, and keep the azimuth that highest emission is indicated on the spectrum analyzer. Vary the antenna position again and record the highest value as a final reading.

Note : A band pass filter was used to avoid pre-amplifier saturated when measure TX operation mode in frequency band above 1 GHz.

5. Repeat step 4 until all frequencies need to be measured were complete.
6. Repeat step 5 with search antenna in vertical polarized orientations.
7. Check the three frequencies of highest emission with varying the placement of cables associated with EUT to obtain the worse case and record the result.

Figure 1 : Frequencies measured below 1 GHz configuration

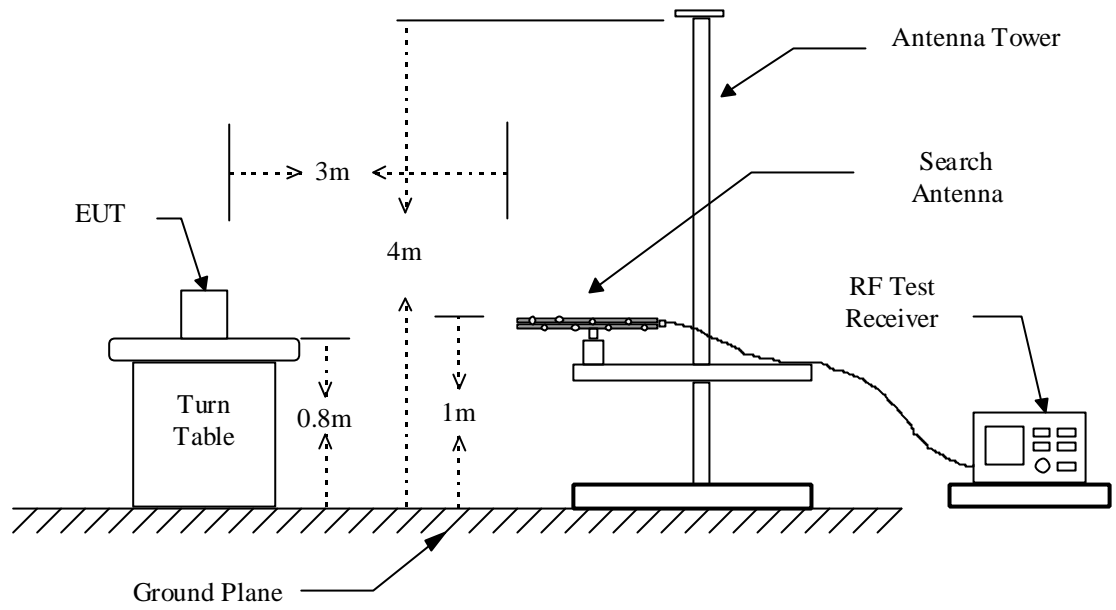
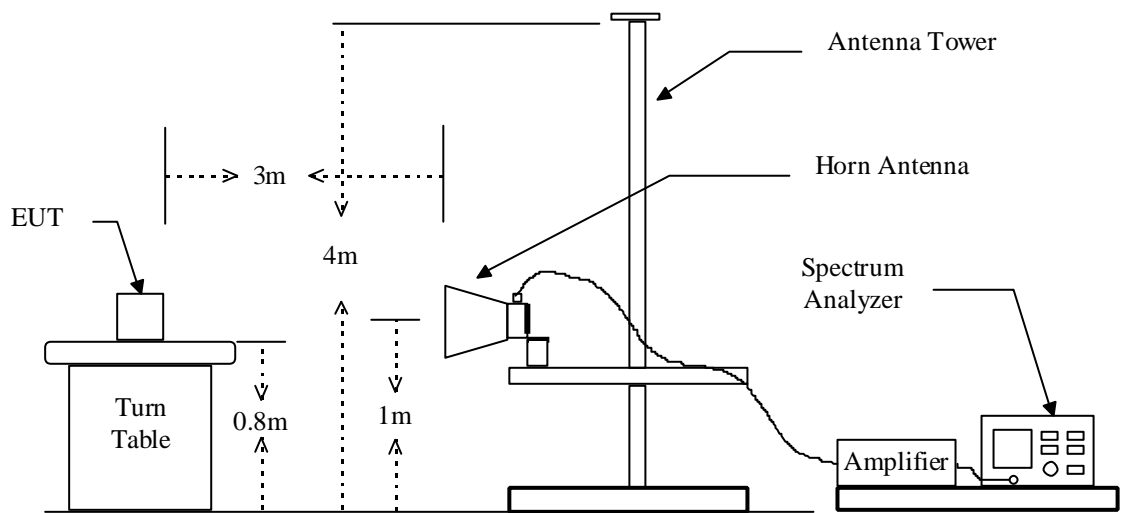

Figure 2 : Frequencies measured above 1 GHz configuration



### 4.3 Test Data

#### A. Fundamental and Harmonic

Operation Mode : Transmitting

Test Date : Dec. 14, 2004      Temperature : 22 °C      Humidity : 69 %

Frequency (MHz)	Ant Pol H/V	Reading (dBuV) Peak	Factor (dB)		Result @3m (dBuV/m)		Limit @3m (dBuV/m)		Margin (dB)	Table Degree (Deg.)	Ant. High (m)
			C	D	Peak	Ave.	Peak	Ave.			
315.046	H	57.4	19.0	-8.8	76.4	67.6	95.6	75.6	-8.0	180	1.0
630.092	H	13.0	26.4	-8.8	39.4	30.6	75.6	55.6	-25.0	0	1.2
945.138	H	8.8	33.4	-8.8	42.2	33.4	75.6	55.6	-22.2	180	1.1
1260.184	H/V	---	-38.5	-8.8	---	---	75.6	55.6	---	---	---
*1575.230	H/V	---	-37.5	-8.8	---	---	74.0	54.0	---	---	---
*1890.276	H/V	---	-34.0	-8.8	---	---	75.6	55.6	---	---	---
*2205.322	H/V	---	-31.9	-8.8	---	---	74.0	54.0	---	---	---
2520.368	H/V	---	-30.5	-8.8	---	---	75.6	55.6	---	---	---
2835.414	H/V	---	-29.1	-8.8	---	---	74.0	54.0	---	---	---
3150.457	H/V	---	-28.0	-8.8	---	---	75.6	55.6	---	---	---

Note :

1. Factor C means "corrected", and that includes antenna factor, cable loss, amplifier gain (if any). And Factor D means "Duty", that is for calculating the average value and derived from section 3.6 in this test report.
2. Peak Result = Reading + C. Factor  
Ave. Result = Peak Value + D Factor
3. "\*" means the frequency fall in the restricted frequency band, and the limit of emission is referred to FCC class B
4. The limit for spurious emissions refers to FCC §5.231.
5. The expanded uncertainty of the radiated emission tests is 3.53 dB.

If the measured frequencies fall in the restricted frequency band, the limit employed is § 15.209 general requirement when frequencies are below or equal to 1 GHz. And the measuring instrument is set to quasi peak detector function, no duty factor applied.

**B. Other Emission**

a) Emission frequencies below 1 GHz

Test Date : Dec. 14, 2004Temperature : 22 °CHumidity : 69 %

Frequency (MHz)	Ant-Pol H/V	Meter Reading (dBuV)	Corrected Factor (dB)	Result @3m (dBuV/m)	Limit @3m (dBuV/m)	Margin (dB)	Table Degree (Deg.)	Ant. High (m)
30.000	H/V	---	-9.8	---	40.0	---	85	1.1
50.000	H/V	---	-14.1	---	40.0	---	103	1.0
80.000	H/V	---	-15.0	---	40.0	---	125	1.1
150.000	H/V	---	-10.0	---	43.5	---	75	1.0
350.000	H/V	---	-10.5	---	46.0	---	236	1.1
500.000	H/V	---	-4.4	---	46.0	---	177	1.0
800.000	H/V	---	0.7	---	46.0	---	205	1.0

Note :

1. Remark "---" means that the emission level is too low to be measured.
2. The expanded uncertainty of the radiated emission tests is 3.53 dB.

b) Emission frequencies above 1 GHz

Radiated emission frequencies above 1 GHz to 5 GHz were too low to be measured with a pre-amplifier of 35 dB.

#### 4.4 Field Strength Calculation

The field strength is calculated by adding the Antenna Factor and Cable Factor, and subtracting the Amplifier Gain (if any) from the measured reading. For the limit is employed average value, therefore the peak value can be transferred to average value by subtracting the duty factor. The basic equation with a sample calculation is as follows:

$$\text{Peak} = \text{Reading} + \text{Corrected Factor}$$

where

Corr. Factor = Antenna Factor + Cable Factor - Amplifier Gain (if any)

And the average value is

$$\text{Average} = \text{Peak Value} + \text{Duty Factor}$$

*Note : If the measured frequencies are fall in the restricted frequency band, the limit employed must be quasi peak value when frequencies are below or equal to 1 GHz. And the measuring instrument is set to quasi peak detector function.*

#### 4.5 Activate Time

This transmitter is activated automatically when the sensor detects situation, it ceases transmission within 5 seconds after activation.

#### 4.6 Calculation of Duty Factor

The duty factor is calculated with following formula :

$$20 \log \frac{\text{Total Duty}}{\text{Period of Pulse Train}}$$

315.046 MHz

$$\text{Duty Factor} = 20 \log \frac{(611.111 \mu \text{s} \times 24) + (233.334 \mu \text{s} \times 17)}{51.288 \text{ms}} = -8.8 \text{dB}$$

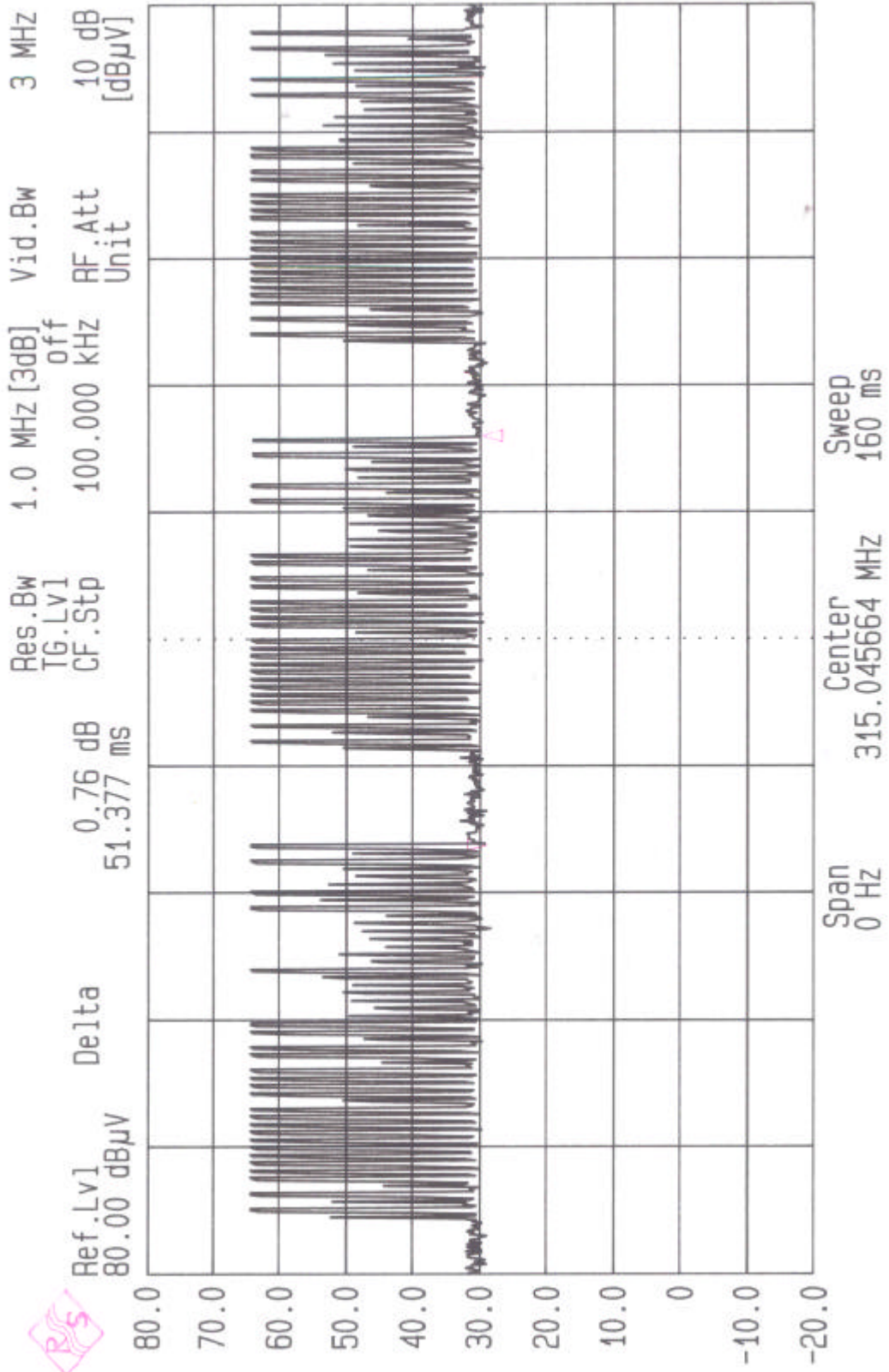

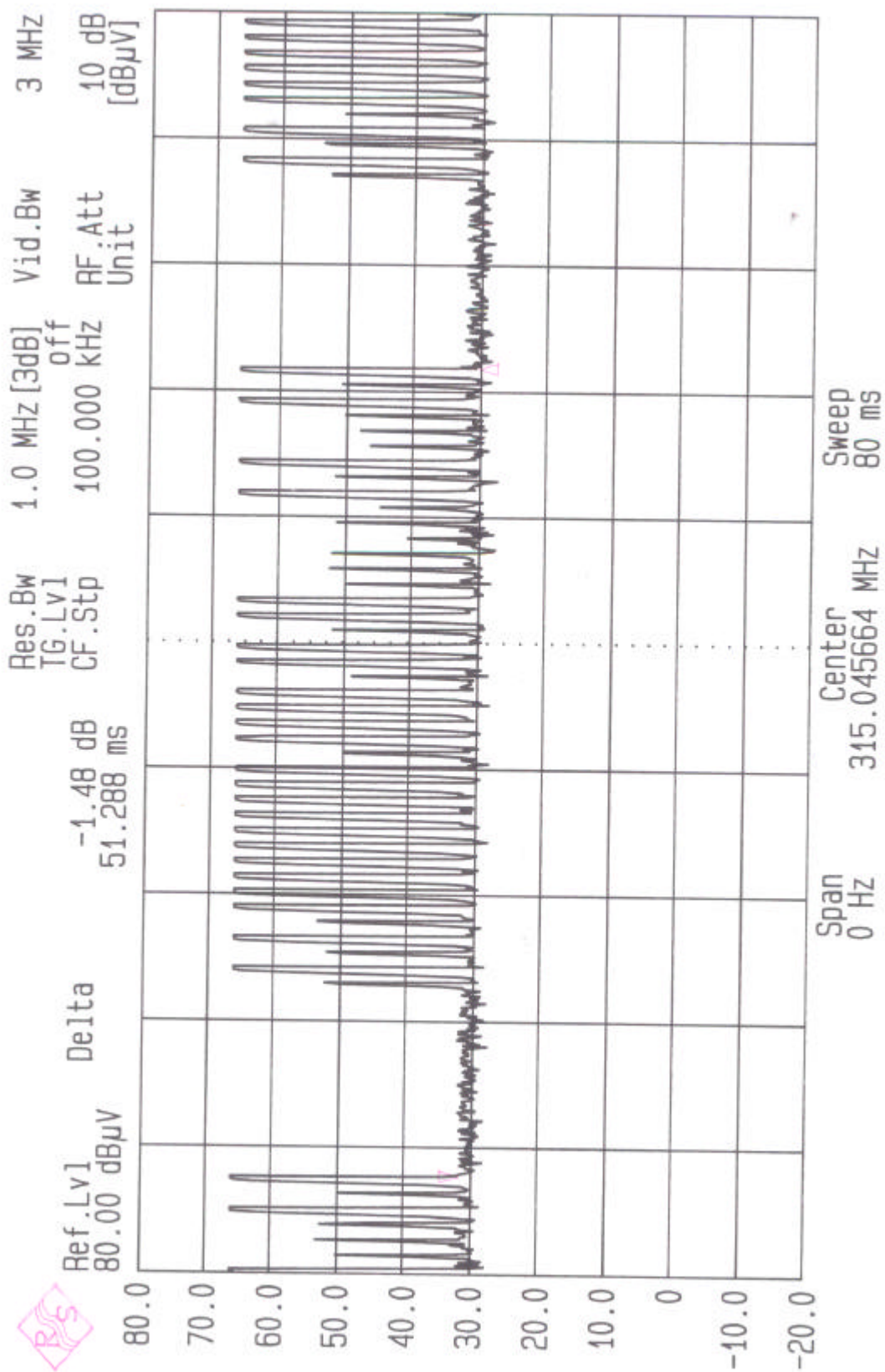

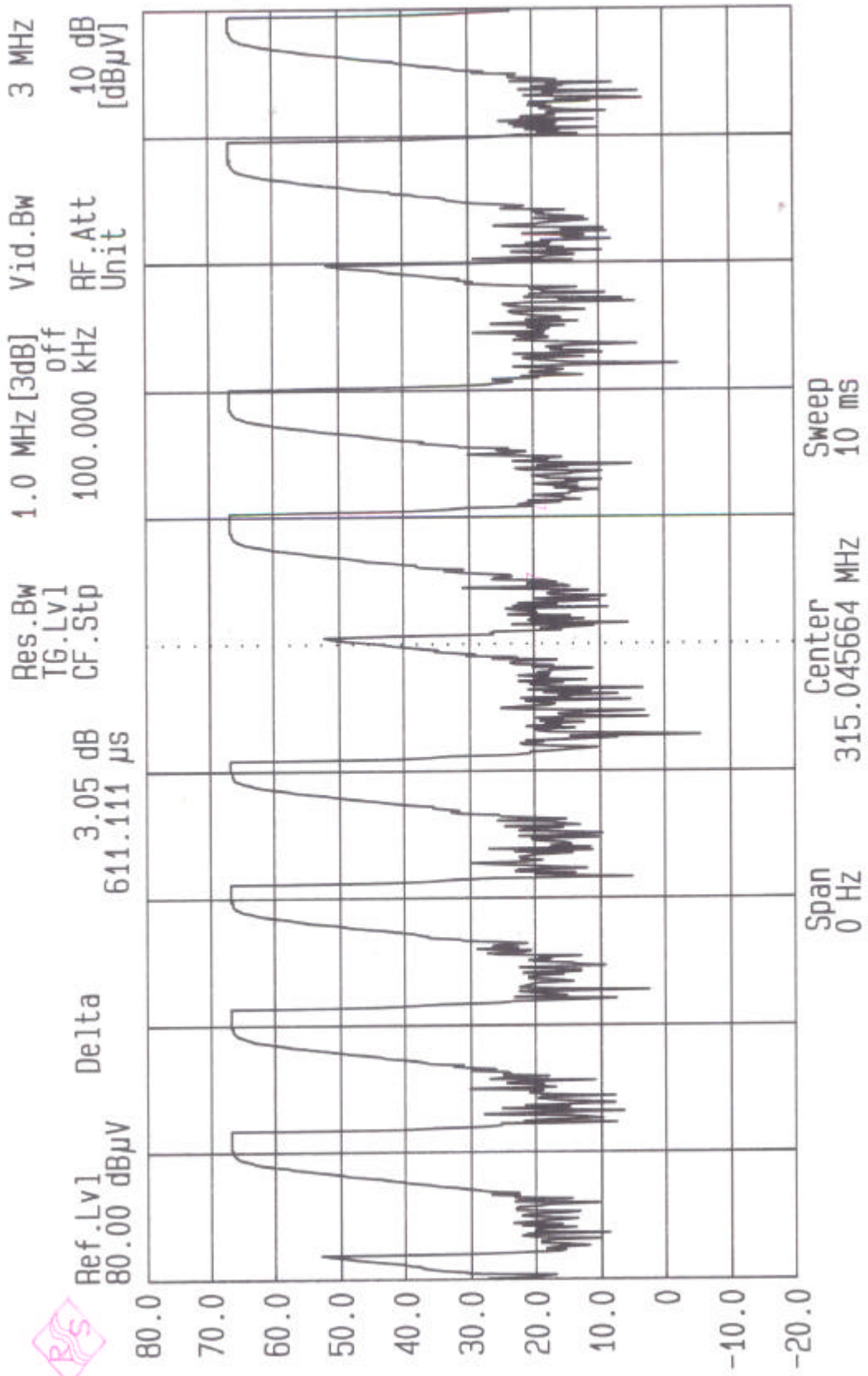



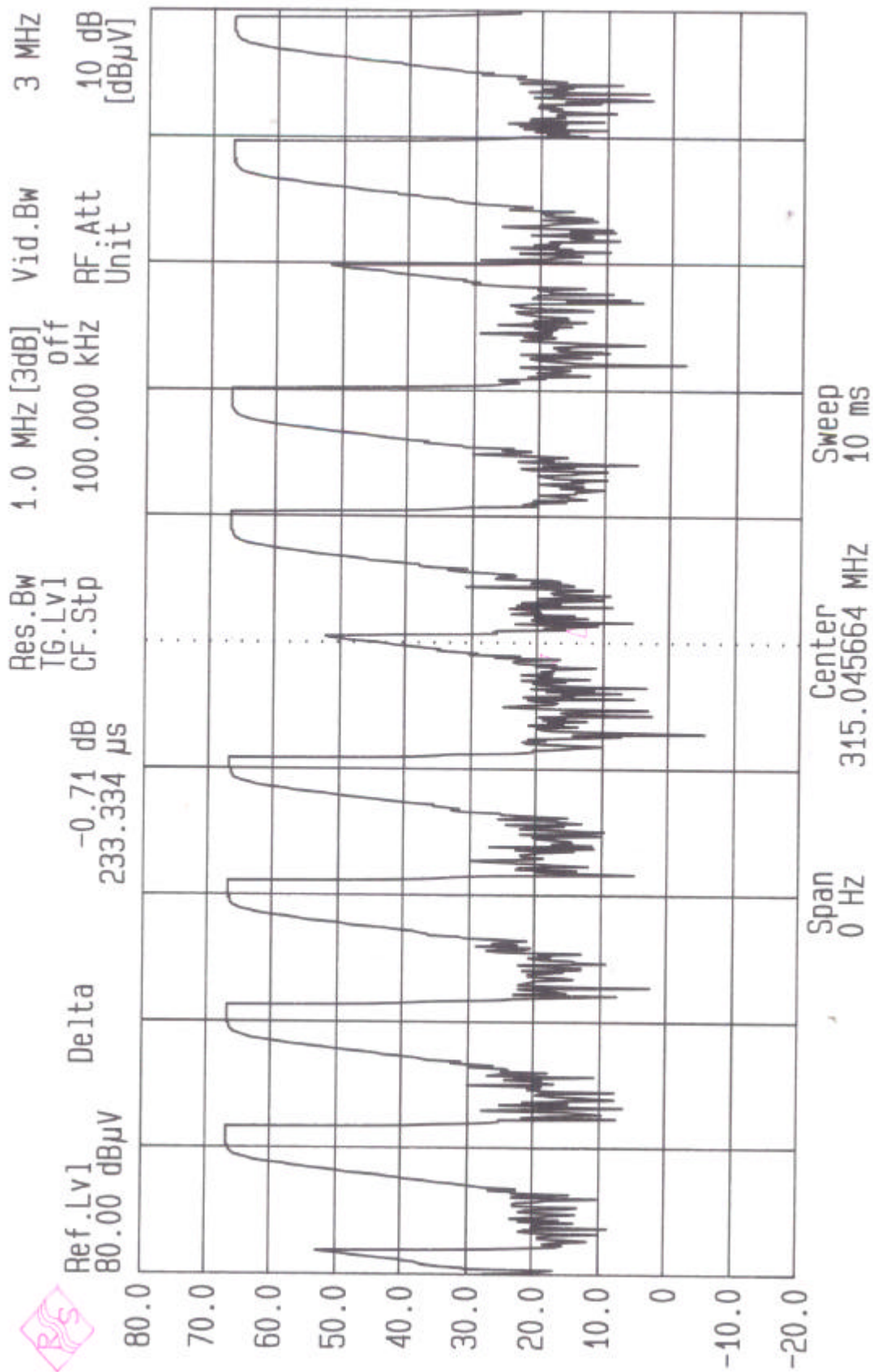

**4.7 Radiated Test Equipment**

<b>Equipment</b>	<b>Manufacturer</b>	<b>Model No.</b>	<b>Next Cal. Date</b>
Spectrum Analyzer	Hewlett-Packard	8564E	08/11/2005
RF Test Receiver	Rohde & Schwarz	ESVS 30	09/05/2005
Horn Antenna	EMCO	3115	03/17/2005
Log periodic Antenna	EMCO	3146	12/05/2005
Biconical Antenna	EMCO	3110B	12/22/2004
Preamplifier	Hewlett-Packard	83051A	03/31/2005
Preamplifier	Hewlett-Packard	8447D	02/18/2005

**4.8 Measuring Instrument Setup**

Explanation of measuring instrument setup in frequency band measured is as following :

Frequency Band (MHz)	Instrument	Function	Resolution bandwidth	Video Bandwidth
30 to 1000	RF Test Receiver	Quasi-Peak	120 kHz	N/A
	Spectrum Analyzer	Peak	100 kHz	100 kHz
Above 1000	Spectrum Analyzer	Peak	1 MHz	1 MHz
	Spectrum Analyzer	Average	1 MHz	10 Hz

### 4.9 Radiated Measurement Photos



## 5. BANDWIDTH OF EMISSION

### 5.1 Applicable Standard Plot Graphic of Bandwidth

Per FCC rule 15.231(c), the permitted emission bandwidth is no wider than 0.25% of the center frequency for devices operating above 70 MHz and below 900 MHz.

### 5.2 Bandwidth Test Equipment

Equipment	Manufacturer	Model No.	Next Cal. Date
Test Receiver	Rohde & Schwarz	ESBI	05/31/2005
Plotter	Hewlett-Packard	7550A	N/A

### 5.3 Plot Graphic of Bandwidth

The emission bandwidth limit for this transmitter is

$$315.046\text{MHz} \times 0.25\% = 787.614\text{KHz}$$

$$20 \text{ dB bandwidth} = 151.100\text{KHz}$$

**Test Result: 151.100KHz < 787.614KHz.**

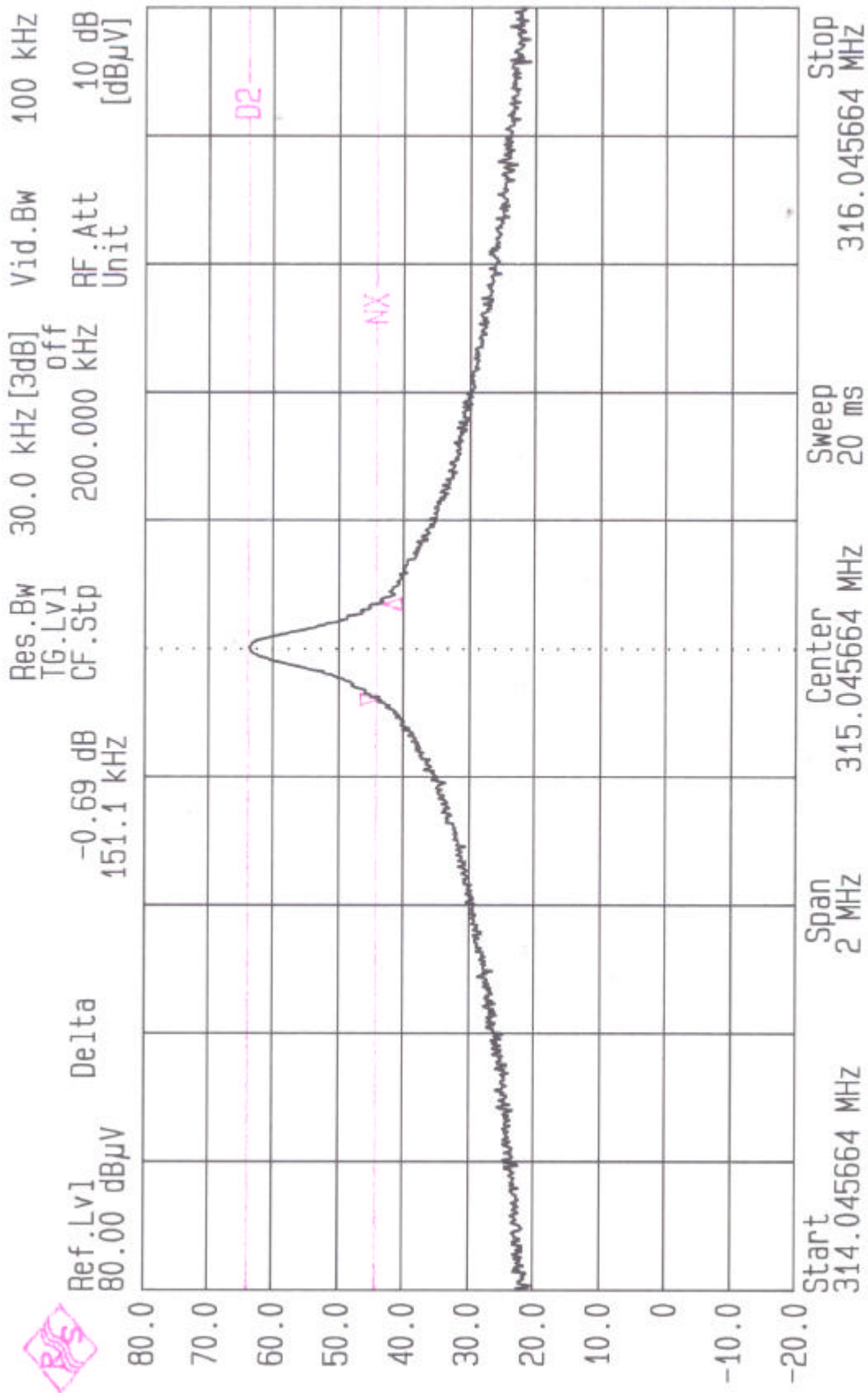

## **6. CONDUCTED EMISSION MEASUREMENT**

### **6.1 Description**

This EUT is excused from investigation of conducted emission, for it is powered by DC 9V battery only. According to 15.207(d), measurements to demonstrate compliance with the conducted limits are not required for devices which only employ battery power for operation and which do not operate from the AC power lines or contain provisions for operation while connected to the AC power lines.

## **7 ANTENNA REQUIREMENT**

### **7.1 Standard Applicable**

According to 15.203, an intentional radiator shall be designed to ensure that no antenna other than that furnished by the responsible party shall be used with the device.

### **7.2 Antenna Construction**

The antenna is permanently mounted on RF Board, no consideration of replacement.  
Please see photos submitted in Exhibit B.