

ENFORCER Wireless Help Button

Changing the Battery:

The Wireless Help Button has a multi-colored LED that illuminates blue when the button is pressed. When the battery begins to run low, the LED will illuminate red. To change the battery:

1. Remove the two screws from the front of the plate and remove the plate from the back box.
2. Remove the battery clip from the 9V battery and remove the battery from the bracket.
3. Place the new battery in the bracket and snap the battery clip to the new battery.
4. Test the unit with the new battery. The LED should illuminate blue.
5. Put the plate back in the back box and secure it to the back box using the screws on the front.

Troubleshooting:

LED does not light	<ul style="list-style-type: none">• Check battery connection• Replace 9V battery
LED lights blue, but does not activate lock	<ul style="list-style-type: none">• Ensure Wireless Help Button is not housed in a metal box• Test Wireless Help Button closer to the receiver• Clear codes from receiver and re-learn wireless transmitter code

Also Available from SECO-LARM®:

2-Channel RF Receiver



SK-910RB2Q

1-Button Handheld RF Transmitter



SK-919TP1H-BUQ

Room Monitor Kit



RM-R100-KB1Q

IMPORTANT: Users and installers of this product are responsible for ensuring this product complies with all national, state, and local laws and statutes related to monitoring and recording audio and video signals. SECO-LARM will not be held responsible for the use of this product in violation of any current laws or statutes.

FCC COMPLIANCE STATEMENT

FCC ID: K4ER100TBQ

THIS DEVICE COMPLIES WITH PART 15 OF THE FCC RULES. OPERATION IS SUBJECT TO THE FOLLOWING TWO CONDITIONS: (1) THIS DEVICE MAY NOT CAUSE HARMFUL INTERFERENCE AND (2) THIS DEVICE MUST ACCEPT ANY INTERFERENCE RECEIVED, INCLUDING INTERFERENCE THAT MAY CAUSE UNDESIRE OPERATION.

Notice: The changes or modifications not expressly approved by the party responsible for compliance could void the user's authority to operate the equipment.

IMPORTANT NOTE: To comply with the FCC RF exposure compliance requirements, no change to the antenna or the device is permitted. Any change to the antenna or the device could result in the device exceeding the RF exposure requirements and void user's authority to operate the device.

WARRANTY: This SECO-LARM product is warranted against defects in material and workmanship while used in normal service for one (1) year from the date of sale to the original customer. SECO-LARM's obligation is limited to the repair or replacement of any defective part if the unit is returned, transportation prepaid, to SECO-LARM. This Warranty is void if damage is caused by or attributed to acts of God, physical or electrical misuse or abuse, neglect, repair or alteration, improper or abnormal usage, or faulty installation, or if for any other reason SECO-LARM determines that such equipment is not operating properly as a result of causes other than defects in material and workmanship. The sole obligation of SECO-LARM and the purchaser's exclusive remedy, shall be limited to the replacement or repair only, at SECO-LARM's option. In no event shall SECO-LARM be liable for any special, collateral, incidental, or consequential personal or property damage of any kind to the purchaser or anyone else.

NOTICE: The SECO-LARM policy is one of continual development and improvement. For that reason, SECO-LARM reserves the right to change specifications without notice. SECO-LARM is also not responsible for misprints. All trademarks are the property of SECO-LARM U.S.A., Inc. or their respective owners. Copyright © 2018 SECO-LARM U.S.A., Inc. All rights reserved.

SECO-LARM® U.S.A., Inc.

16842 Millikan Avenue, Irvine, CA 92606
Phone: (949) 261-2999 | (800) 662-0800

Website: www.seco-larm.com
Email: sales@seco-larm.com

 PITSW1
Order Part# 763-190%
MI_RM-R100-TBQ_181211.docx



RM-R100-TBQ

SD-862M-GWSQ

Wireless Help Button

Manual



Features:

- Built-in RF transmitter:
 - Powered by 9VDC (battery included)
 - Range up to 250ft (76m)*, 433.92MHz
 - Over 68 billion (6.8x10¹⁰) possible codes
 - LED to indicate transmission and low battery
- ABS Plastic single-gang plate with surface mount back box
- Clear 2" square button
- "Push for Help" message plate included
- Requires RM-R100-KB1Q, or SK-910 (433.92MHz) series receiver
- Desktop or wall mounted

*Actual operating range will vary greatly depending on the installation and operating environment.

SECO-LARM® SLI®



Introduction:

The ENFORCER Wireless Help Button can be used to wirelessly expand the Room Monitor (RM-R100-KB1Q) with a service/help button. The button is perfect for placing on a desktop, mounting on walls, or any other location where it is difficult to run wires. The Wireless Help Button combines the very best of SECO-LARM, flexible wireless solutions and reliable access control.

Parts List:

1x Wireless Help Button	1x Back box	2x Wall plate screws
2x Mounting screws	2x Wall anchors	1x 9V Alkaline battery
4x Adhesive rubber feet	1x Manual	

Specifications:

Operating frequency		433.92MHz
Operating voltage		9VDC
Maximum range		250' (76m)*
Battery life		Up to four (4) years (60 uses per day)
Dimensions	Desktop	4 ⁵ / ₈ "x2 ⁷ / ₈ "x1 ⁷ / ₈ " (117x73x48 mm)
	Wall mount	4 ⁵ / ₈ "x2 ⁷ / ₈ "x2" (117x73x50 mm)
Weight		6-oz (178g)

*Actual operating range will vary greatly depending on the installation and operating environment.

Overview:

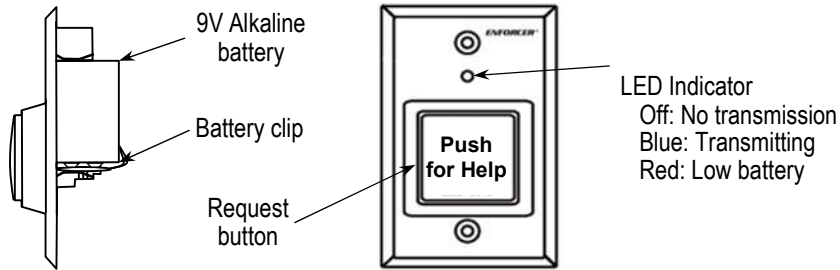

Dimensions:

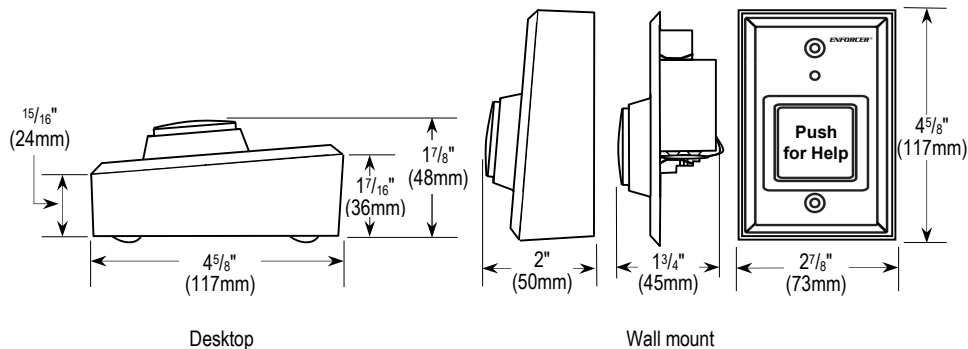

Installation:

- Find a suitable location for the Wireless Help Button.
NOTE: Do not house in a metal box as this will greatly reduce the range.
- The Wireless Help Button can either be wall mounted (taller side of back box on bottom), or placed on a desktop (taller side of back box on top).
- Test the operation of the Wireless Help Button in the location where it will be installed before finalizing the installation.
NOTE: The Wireless Help Button needs to be programmed into the RM-R100-RB1Q or a SK-910 (433.92MHz) series receiver before testing. See the receiver manual for transmitter learning procedure.
- Ensure the battery clip is securely connected, mount the Wireless Help Button in the back box according to the appropriate orientation stated above, and secure it with the two included screws. Apply the included adhesive rubber feet for desktop applications.

Changing the Message Plate:

You can easily print your own message plate on very thin card stock, no thicker than the included message plate, and trim to 1 7/8" (37mm) square.

NOTE: Thicker card stock will not allow the transparent lens to fully seat.

- Use the tip of a very thin screwdriver to pry off the transparent lens over the message plate (see Fig. 1).
- Replace the current plate with the desired message plate, keeping the spacer plate in place.
- Check that message plate orientation is correct.
- Carefully snap the lens assembly back on.

Fig. 1

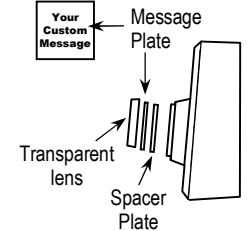

RM-R100-TBQ Sample Applications:

Basic Installation with Room Monitor Kit (RM-R100-KB1Q)

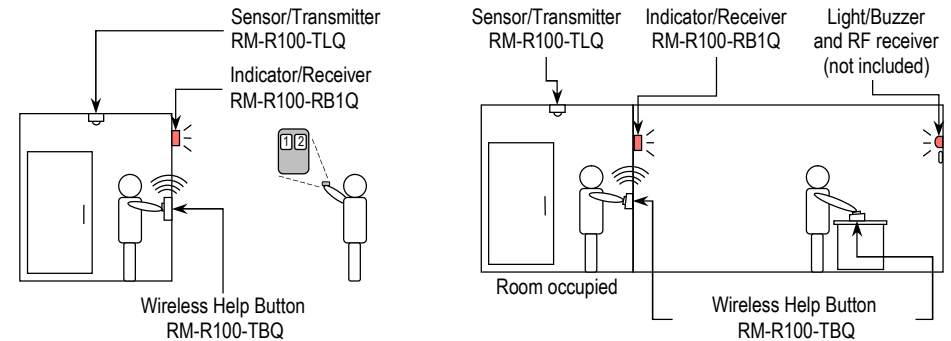

Room occupied – indicator/receiver LED is lit.
Wireless pushbutton pressed – indicator/receiver LED flashes and/or buzzer sounds
Attendant uses wireless remote (not included) to reset the indicator flashing LED and/or buzzer.

Room occupied – remote indicator/receiver LED is lit.
Wireless pushbutton pressed – light/buzzer connected to a 433.92MHz RF receiver outside door is triggered and remote indicator/receiver LED flashes and/or buzzer sounds
Attendant uses wireless pushbutton (or wireless remote, not included) to reset the Indicator flashing LED and/or buzzer.