

ENFORCER Wireless Video Door Phone

Also Available from **SECO-LARM®**:

Additional Monitor



DP-266-M3Q

Additional Camera



DP-266-CQ

2-Wire Hands-Free Video Door Phone



DP-234Q

2-Wire Color Video Door Phone



DP-222Q

Wireless Intercom



DP-T100-2Q

CBA® Wireless Alert System



RA-4961-K1Q

IMPORTANT: Users and installers of this product are responsible for ensuring this product complies with all national, state, and local laws and statutes related to monitoring and recording audio and video signals. SECO-LARM will not be held responsible for the use of this product in violation of any current laws or statutes.

FCC COMPLIANCE STATEMENT

DP-266-M3Q FCC ID: K4E266M3Q

DP-266-CQ FCC ID: K4E266CQ

Changes or modifications not expressly approved by the party responsible for compliance could void the user's authority to operate the equipment. This equipment has been tested and found to comply with the limits for a Class B digital device, pursuant to Part 15 of the FCC Rules. These limits are designed to provide reasonable protection against harmful interference in a residential installation. This equipment generates uses and can radiate radio frequency energy and, if not installed and used in accordance with the instructions, may cause harmful interference to radio communications. However, there is no guarantee that interference will not occur in a particular installation. If this equipment does cause harmful interference to radio or television reception, which can be determined by turning the equipment off and on, the user is encouraged to try to correct the interference by one or more of the following measures:

- Reorient or relocate the receiving antenna.
- Increase the separation between the equipment and receiver.
- Connect the equipment into an outlet on a circuit different from that to which the receiver is connected.
- Consult the dealer or an experienced radio/TV technician for help.

WARRANTY: This SECO-LARM product is warranted against defects in material and workmanship while used in normal service for one (1) year from the date of sale to the original customer. SECO-LARM's obligation is limited to the repair or replacement of any defective part if the unit is returned, transportation prepaid, to SECO-LARM. This Warranty is void if damage is caused by or attributed to acts of God, physical or electrical misuse or abuse, neglect, repair or alteration, improper or abnormal usage, or faulty installation, or if for any other reason SECO-LARM determines that such equipment is not operating properly as a result of causes other than defects in material and workmanship. The sole obligation of SECO-LARM and the purchaser's exclusive remedy, shall be limited to the replacement or repair only, at SECO-LARM's option. In no event shall SECO-LARM be liable for any special, collateral, incidental, or consequential personal or property damage of any kind to the purchaser or anyone else.

NOTICE: The SECO-LARM policy is one of continual development and improvement. For that reason, SECO-LARM reserves the right to change specifications without notice. SECO-LARM is also not responsible for misprints. All trademarks are the property of SECO-LARM U.S.A., Inc. or their respective owners. Copyright © 2018 SECO-LARM U.S.A., Inc. All rights reserved.

SECO-LARM® U.S.A., Inc.

16842 Millikan Avenue, Irvine, CA 92606
Phone: (949) 261-2999 | (800) 662-0800

Website: www.seco-larm.com
Email: sales@seco-larm.com

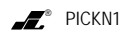

ML_DP-266-1C3Q_180628.docx



DP-266-1C3Q

Wireless Video Door Phone

Manual



Features:

- Wireless operation – camera and monitor can operate from up to 492ft (150m)** away
- Remotely and securely talk to visitors and unlock doors or gates via the monitor
- Lightweight monitor can be carried around the premises while talking to the visitor
- Connect up to two additional monitors and one additional camera*
- Intercom calling between paired monitors*
- Camera has built-in IR LEDs for nighttime operation
- Camera includes a built-in PIR sensor that activates the camera and takes photos of the visitor when they approach
- Monitor includes a kickstand and a charging base
- Camera powered by 9-16 VAC/5-16 VDC
- Monitor front door at any time
- Egress input
- 170° wide field of view
- Adjustable camera pan and tilt angle—up to 20° from centerline in any direction—to allow for mounting variations

*Additional monitors and camera sold separately.

**Line-of-sight range. Actual range may vary depending on the installation and operating environment.

SECO-LARM® SLI®



Table of Contents:

Introduction.....	2	Programming and Using the	
Parts List.....	2	On-Screen Display.....	9-10
Specifications	3	Programming the Advanced Settings	10-11
Overview.....	3	Operating the Wireless	
Display Overview.....	4	Video Door Phone	12-13
Installation Notes.....	4	Resetting the Camera and	
Camera Wiring Diagram.....	5	Pairing a First Monitor.....	13-14
Sample Application.....	5	Pairing Additional Monitors or Cameras	14
Installation – Camera	6	Tamper Alarm	15
Installation – Monitor	6-7	Troubleshooting	15
On-Screen Display Features.....	8	Warranty.....	16

Introduction:

The ENFORCER Wireless Video Door Phone is a convenient and secure way to monitor and control an entryway, such as a door or gate, from up to 492 feet (150 meters) away.

When a guest or visitor presses the doorbell button on the camera unit, the homeowner can use one of up to three lightweight, wireless LCD monitors to see whom is requesting entry, speak with the caller, take a photo, and decide whether or not to grant entry. The video door phone can be expanded with up to two additional monitors and one additional camera. If multiple monitors are set up, then the system can also be used as an intercom system between each monitor.

Parts List:

DP-266-1C3Q

Complete Kit

- 1x Monitor (DP-266-M3Q)*
- 1x Camera (DP-266-CQ)*
- 1x Monitor charging stand
- 1x Monitor kick stand
- 1x AC Power adapter with USB port (for monitor)
- 1x USB Cable
- 1x Monitor battery
- 1x Camera mounting hood bracket
- 1x AC Power adapter with DC plug (for camera)
- 1x DC Jack with pigtail
- 1x Camera battery
- 3x Camera mounting screws
- 3x Camera mounting screw anchors
- 1x Camera screw
- 1x Camera screw cover
- 1x Manual

DP-266-M3Q

Additional Monitor Unit

- 1x Monitor (DP-266-M3Q)**
- 1x Monitor charging stand
- 1x Monitor kick stand
- 1x AC Power adapter with USB port (for monitor)
- 1x USB Cable
- 1x Monitor battery
- 1x Manual

DP-266-CQ

Additional Camera Unit

- 1x Camera (DP-266-CQ)**
- 1x Camera mounting hood bracket
- 1x AC Power adapter with DC plug (for camera)
- 1x DC Jack with pigtail
- 1x Camera battery
- 3x Camera mounting screws
- 3x Camera mounting screw anchors
- 1x Camera screw
- 1x Camera screw cover
- 1x Manual

*The DP-266-1C3Q included monitor and camera are paired by default.

**Additional monitors and cameras are not paired by default. See "Pairing Additional Monitors or Cameras" on pg. 14.

Tamper Alarm:

The tamper alarm activates anytime the camera is removed from the bracket, warning the user of possible vandalism. The tamper alarm will sound on the camera and any connected monitors.

1. To disable the tamper alarm if no monitors are paired with the camera:
 - a. Return the camera to the bracket.
 - b. If the alarm persists, unplug the camera and remove the battery.
 - c. Return the camera's battery and reconnect it to power.
2. To disable the tamper alarm if one or more monitors are paired with the camera:
 - a. Repeatedly press the "OK" button on all paired monitors.
 - b. If the alarm persists, unplug the camera and remove the battery.
 - c. Unplug each monitor and remove each monitor's battery.
 - d. Return the camera's battery and reconnect it to power.
 - e. Insert each monitor's battery and reconnect each monitor to power.
3. To permanently disable the tamper alarm, see the "Alarm setting" section in "Programming the Advanced Settings," pg. 11.

Troubleshooting:

The monitor's screen is blank	<ul style="list-style-type: none"> • Make sure the "ON/OFF" or "OK" button was pressed to wake the monitor • Make sure the monitor's battery is charged • Plug the charger directly into the monitor
The monitor is not charging	<ul style="list-style-type: none"> • Remove the battery from the battery compartment and clean both the battery contacts and the monitor's connection contacts • Make sure the kickstand is extended when placing in the charger stand • Make sure the power adapter is correctly connected to the charger stand • Connect the power adapter directly to the monitor
The monitor does not ring	<ul style="list-style-type: none"> • Check that the volume is turned up • Check that the monitor is in standby mode • Check that the monitor is placed in the mounting bracket
The monitor cannot connect to the camera	<ul style="list-style-type: none"> • Check that the monitor has been paired with the camera • Check that the monitor is within range of the camera
The monitor's screen image quality is poor	<ul style="list-style-type: none"> • Adjust the monitor's display brightness • Clean the camera's lens using a soft, clean cloth • Change the position of the camera • Move the monitor away from potential sources of interference (microwaves, television, lamps, etc.)
The monitor is unable to activate the camera's relay	<ul style="list-style-type: none"> • Make sure the user is pressing the "Menu/Unlock" button when in two-way communication (the microphone icon is lit and does not have an "X" through it) • Check the wiring between the camera and the optional door locking device

Resetting the Camera and Pairing a First Monitor (continued):

3. Reconnect the power wires and return the camera to the bracket.
4. Press the doorbell button on the camera to confirm the connection.

Pairing Additional Monitors or Cameras:

NOTE: By default, the monitor in the DP-266-1C3Q Complete Kit is paired with the camera. These instructions apply to pairing a second or third monitor, or a second camera.

To pair an additional monitor:

1. Put the first monitor into pairing mode:
 - a. Select "Give code" from the "Pairing" option in the "Settings" menu.
2. Put the second monitor in pairing mode:
 - a. Select "Receive code" from the "Pairing" option in the "Settings" menu.
 - b. The second monitor will display "Success" and beep three times.
 - c. Press "Exit" on the first monitor to exit pairing mode.
3. Press the doorbell button on the camera to test the connection.
 - a. Answer the call from the newly paired monitor to confirm the connection.
4. To pair a third monitor, use the second monitor to "give code".

NOTE: Up to three total monitors can be learned to the system.

NOTE: The intercom feature will not function until the connection is confirmed by the new monitor.

To pair an additional camera:

1. Put the camera into pairing mode:
 - a. Remove the camera from the bracket.
 - b. If the tamper alarm is active then the alarm will begin to sound.
 - i. Disconnect power from the camera by removing the battery and disconnecting the power wiring.
 - ii. Replace the battery.
 - c. Use a paper clip or other small object to press and hold the camera's reset button for seven to eight seconds. The camera will beep once around four seconds and twice around eight seconds.

NOTE: The camera will remain in pairing mode for ~15 seconds before automatically exiting.

2. Put any monitor in the system into pairing mode:
 - a. Select "Give code" from the "Pairing" option in the "Settings" menu.
3. The camera will beep three times to indicate successful pairing.
4. Press "Exit" on the monitor to exit pairing mode.
5. Reconnect the power wires and return the camera to the bracket.
6. Press the doorbell button on the camera to confirm the connection.

Specifications:

Camera		Monitor	
Type	Color camera	Display	3 3/8" (86mm) TFT
Chip	CMOS	Operating voltage	5VDC (adapter) or 3.7VDC (battery)
Resolution	480 TV Lines	Current draw	Active: 370mA@3.7VDC Standby: 5mA@3.7VDC
Lens	2mm	Battery life	Active: ~2.5 Hours Standby: ~7 Days
Field of view	170°	Operating frequency	2406-2480 MHz
Camera angle adjustment	Up to 20° any direction	Wireless range	492' (150m)*
Operating voltage	9-16 VAC/5-16 VDC	Dimensions	5"x3 3/8"x1 1/8" (127x85x22 mm)
Relock delay	3/6/8 Seconds	Weight	3.9-oz (110g)
Relay output	3A@250VAC/30VDC	Operating temperature	32°-104° F (0°-40° C)
Current draw	Active: 300mA@12VDC Standby: 15mA@12VDC	<i>*Line-of-sight range. Actual range may vary depending on the installation and operating environment.</i>	
Battery life	Active: ~7 Hours Standby: ~60 Days		
IR LED Range	5' (1.5m)		
IR LED Frequency	940nm		
PIR Detection range	9' (3m)		
PIR Detection angle	60°		
Dimensions (with bracket)	5 11/16"x3 3/8"x1 15/16" (144x80x50 mm)		
Weight	4.3-oz (122g)		
Operating temperature	14°-122° F (-10°-50° C)		

Overview:

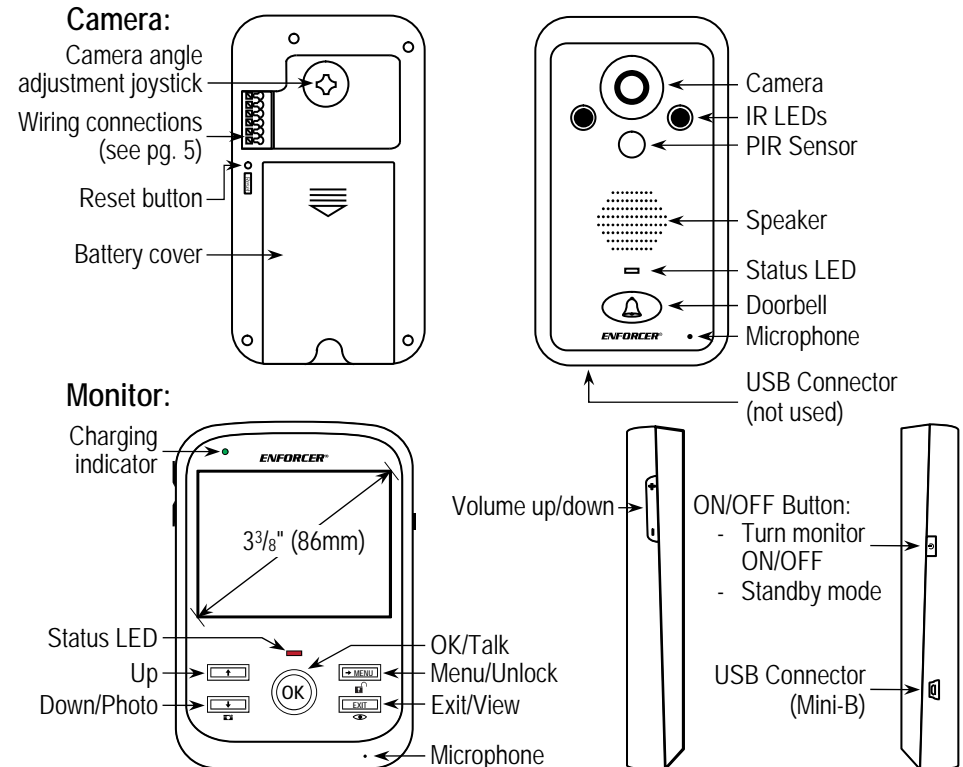

Display Overview:



- 1** : ID – Displays the monitor ID number
- : Signal Strength – Displays the wireless signal strength
- : Communication Mode – Displays current communication mode
 - Bell indicates an incoming call
 - Crossed out microphone indicates one-way communication
 - Microphone indicates two-way communication
- : Message – Displays when there is a message due to a missed call
- : PIR – Displays when the PIR sensor is turned on
- : Photo – Displays when a photo is taken
- : Relay – Displays while the relay is active
- : Alarm – Displays when the tamper alarm has been activated
- : Monitor volume – Displays the current monitor volume
- : Monitor Battery: Displays the current monitor station battery level
- : Camera Battery: Displays the current camera station battery level

Installation Notes:

1. Unpack the video door phone and note the included parts.
2. Read this manual thoroughly. A clear understanding of the manual will make installation and operation much easier.
3. Find a good location to mount the monitor and camera. Approximately 5ft (1.5m) above the ground is optimal, where the visitor would stand approximately 2.5~5 ft (0.8~1.5 m) from the camera. Note that the camera tilt and pan angle can be adjusted up to 20° from centerline to compensate for less than optimal situations (see below).
4. Avoid mounting the camera or monitor near sources of strong electromagnetic signals or other electronic devices that may cause interference.
5. Avoid mounting the camera in direct sunlight or exposing the camera to strong vibrations, direct rain, or moisture, which could result in damage to the camera. Strong backlight or reflection may degrade the resulting video image.
6. The monitor and camera contain no user-serviceable parts. Opening them may damage sensitive components and will void the warranty.

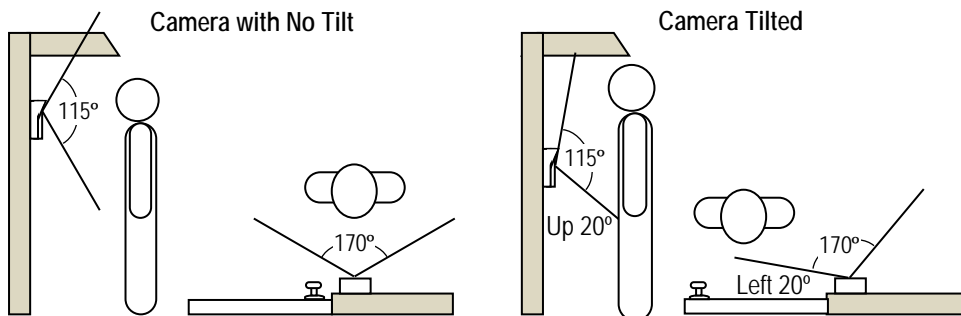

Operating the Wireless Video Door Phone (continued):

Communicating between monitors

NOTE: The Wireless Video Door Phone system can be set up with up to 2 cameras and 3 monitors. If multiple monitors are set up, then the system can be used as an intercom between each monitor. To pair additional monitors see "Pairing Additional Monitors or Cameras," pg. 14.

Intercom feature with two monitors:

1. Make sure both monitors are powered ON.
2. Press the "OK" or "Power" button to turn the monitor's display on.
3. Press the "OK" button to call the other monitor.
4. To accept the call, the other monitor's user must press their "OK" button.
5. Press the "OK" button again when finished with the call.

NOTE: The intercom feature will automatically timeout after 60 seconds.

Intercom feature with three monitors:

1. Make sure all monitors are powered ON.
2. Press the "OK" or "Power" button to turn the monitor's display on.

NOTE: Each paired monitor will have an identification number in the top left corner (1, 2, or 3).
3. Press the "Up" button to call the next highest ID monitor.
4. Press the "Down" button to call the next lowest ID monitor.
 - If monitor 1 is calling monitor 2, the user would press the "Up" button.
 - If monitor 3 is calling monitor 2, the user would press the "Down" button.
 - If monitor 3 is calling monitor 1, the user would press the "Up" button.
5. Press the "OK" button when finished with the call.

Resetting the Camera and Pairing a First Monitor:

NOTE: By default, the monitor in the DP-266-1C3Q Complete Kit is paired with the camera. These instructions apply to resetting the camera and monitor system.

1. Put the camera into pairing mode:
 - a. Remove the camera from the bracket.
 - b. If the tamper alarm is active then the alarm will begin to sound.
 - i. Disconnect power from the camera by removing the battery and disconnecting the power wiring.
 - ii. Replace the battery.
 - c. Use a paper clip or other small object to press and hold the camera's reset button for three to four seconds. A single beep indicates the camera is in pairing mode.

NOTE: The camera will remain in pairing mode for ~15 seconds before automatically exiting.
2. Pair the first monitor to the camera:
 - a. Select "Match code" from the "Pairing" option in the "Settings" menu.
 - b. The monitor will display "Success" and the monitor and camera will beep three times.

Operating the Wireless Video Door Phone:

Communicating with the camera

Request entry:

1. Press the doorbell button on the camera. The indoor monitor will ring and display an image from the camera. The monitor will also display a bell icon.
2. Wait for the indoor user to accept the call and activate the onboard relay as necessary.

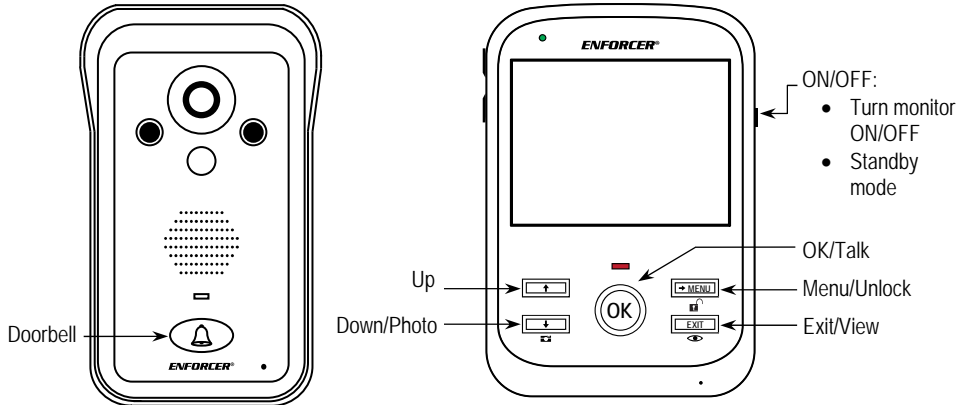

Receive a visitor:

1. If a visitor presses the doorbell button on the camera, the monitor's display turns ON and the monitor sounds the chosen ring tone.
2. Press the "OK" button to accept the call. The bell icon will change to a microphone icon.
3. Press the "Menu/Unlock" button on the monitor to activate the camera's onboard relay.
4. Press the "Exit/View" button to mute the monitor (the camera station can still be heard on the indoor monitor).
5. Press the "Down/Photo" button on the monitor to take a manual photo.
6. Press the "Volume up/down" button to adjust the audio level.
7. Press the "OK" button when finished with the call.

View and/or talk to a visitor who has not pressed the doorbell button on the camera:

1. Press the "OK" or "Power" button to turn the monitor's display ON.
2. Press the "Exit/View" button to monitor the camera station.
NOTE: If multiple cameras are connected then use the "Up" or "Down" button to select the desired camera station to monitor. Press "OK" to connect to the selected camera.
3. The user can now view and hear the camera station. The microphone icon will have an "X" through it.
4. Press the "Exit/View" button to activate two-way communication. The microphone's "X" will be removed.
5. To unlock the optional electronic door lock, press the "Menu/Unlock" button to activate the relay.
6. Press the "Down/Photo" button to take a manual photo.
7. Press the "OK" button when finished with the call.

Camera Wiring Diagram:

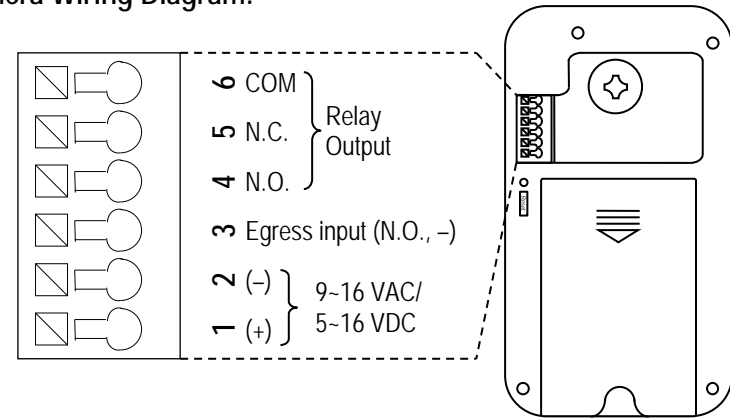

1. Positive (+) power input – Connect to the red wire of the included AC adapter or to the positive wire of the doorbell's power supply.
2. Negative (-) power input – Connect to the black wire of the included AC adapter or to the negative wire of the doorbell's power supply.
3. Egress (N.O.) negative input – Connect to an optional N.O. egress device. The egress device will activate the relay for the same length as the lock delay. (See the "Unlocking duration" section in "Programming the Advanced Settings," pg. 11).
4. N.O. (Normally opened) output – Wire to the lock device for fail-secure operation.
5. N.C. (Normally closed) output – Wire to the lock device for fail-safe operation.
6. Common output – Wire to the power supply of the lock device.

NOTE: For 16VAC doorbell installation, wire directly from the doorbell's transformer.

Sample Application:

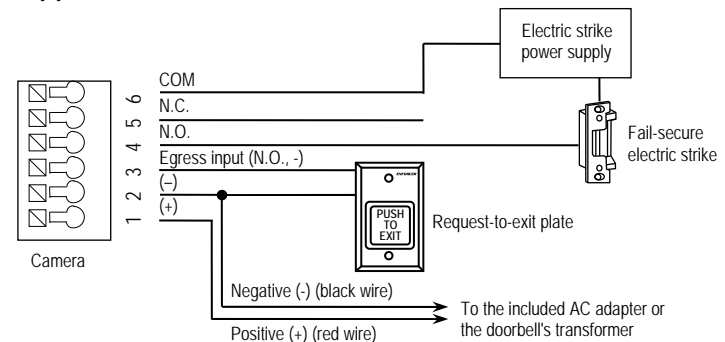

- The camera is connected to its included AC adapter.
- The egress input is connected to a Request-to-Exit Plate. The homeowner can exit the premises by pressing this button.
- The N.O. (normally open) output is wired to an electric lock. The camera and the Request-to-Exit Plate both activate the strike, allowing entry or egress.
- The electric lock's power supply is wired to the COM (common) output.

Installation – Camera:

1. Position the camera so the area to be monitored is easily visible, optimally 5ft (1.5m) above the ground. Do not position the camera in direct sunlight, or where it will be exposed directly to rain or snow.
NOTE: For best results, the visitor should stand 2.5-5 ft (0.8-1.5 m) away from the camera.
2. Cut a hole large enough to run the min. 21AWG 2-conductor wire to the door unlock device through the wall, as well as to the included power supply.
3. Mount the camera bracket to the wall with three screws. Use screw anchors if the bracket is mounted on drywall or brick.
4. Run the 2-conductor wire from the camera, through the wire hole in the bracket, to the optional door unlock device.
5. Install the rechargeable lithium ion battery into the camera. The battery will act as a backup power source in case of a power outage.
6. Connect the AC adapter (see "Camera Wiring Diagram," pg. 5).
7. Install the monitor battery (see below) and turn on the camera and monitor. If the camera is not in the bracket, the tamper alarm will sound. Press the "OK" button on the monitor repeatedly to disable the tamper alarm.
8. Experiment with the camera angle using the joystick on the back of the camera to adjust the direction of the camera while viewing the image on the monitor.
9. Mount the camera into the bracket:
 - Push the top of the camera into the top of the bracket.
 - Push the bottom of the camera into the bottom of the bracket.
 - Screw in the bottom of the camera to fix the camera into the bracket and push the plastic screw cover into the bottom of the bracket, over the screw.

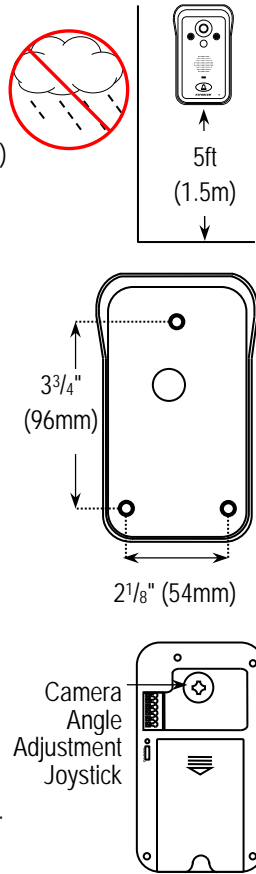

NOTE: Do not block the PIR sensor on the camera.

Installation – Monitor:

Install the monitor battery:

Remove the battery cover on the back of the monitor and insert the included BP-6M lithium-ion battery.

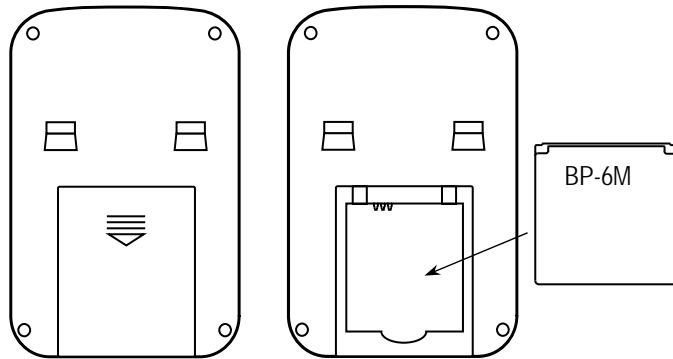

Programming the Advanced Settings (continued):

Unlocking duration:

1. Select "Unlocking duration" and press the "OK" button.
2. Select from 3, 6, or 8 seconds and press the "OK" button.
NOTE: If multiple cameras are paired to the monitor then select the desired camera.
3. The monitor will connect to the desired camera.
4. Press the "OK" button to confirm.
NOTE: A single beep from the camera indicates 3 seconds, a double beep indicates 6 seconds, and a triple beep indicates 8 seconds.

Pairing:

See the "Resetting the Camera and Pairing a First Monitor" and "Programming Additional Monitors or Cameras" sections on pgs. 13-14 for information regarding the "Pairing" setting.

Alarm setting:

1. Select "Alarm setting" and press the "OK" button.
2. Select "On" or "Off" to turn the tamper alarm on or off and press the "OK" button.
NOTE: If multiple cameras are paired to the monitor then select the desired camera.
3. The monitor will connect to the desired camera.
4. Press the "OK" button to confirm.
NOTE: A single beep from the camera indicates the tamper alarm has been turned OFF. A double beep indicates the tamper alarm has been turned ON.

Version:

1. Select "Version" and press the "OK" button.
2. View the version number.

Programming and Using the On-Screen Display (continued):

Programming the time and date:

1. While the monitor display is on, press the "Menu/Unlock" button to open the on-screen display.
2. Highlight the "Time" icon and press the "OK" button to enter the "Time" screen.
3. Use the "Up" and "Down" buttons to adjust the value. Use the "Menu/Unlock" button to move to the next value.
4. Press the "OK" button when finished programming to go back to the on-screen display menu.

NOTE: The time is set in 24-hour time format.

Programming the ringer:

1. While the monitor display is on, press the "Menu/Unlock" button to open the on-screen display.
2. Highlight the "Ring" icon and press the "OK" button to enter the "Ring" screen.
3. Use the "Up" and "Down" buttons to select one of four ring tones: Telephone (default), Doorbell, Für Elise, or Jingle Bells.
4. Press the "OK" button when finished programming to go back to the on-screen display menu.

Programming the language:

1. While the monitor display is on, press the "Menu/Unlock" button to open the on-screen display.
2. Highlight the "Language" icon and press the "OK" button to enter the "Language" screen.
3. Use the "Up" and "Down" buttons to select a language: English (default), German, Spanish, French, Russian, or Chinese.
4. Press the "OK" button when finished programming to go back to the on-screen display menu.

Programming the Advanced Settings:

1. While the monitor display is on, press the "Menu/Unlock" button to open the on-screen display.
2. Highlight the "Setup" icon and press the "OK" button to enter the "Setup" screen.
3. Use the "Up" and "Down" buttons to select the advanced settings menu.
4. Press the "OK" button to enter the selected advanced settings menu.

Motion detection:

1. Select "Motion detection" and press the "OK" button.
2. Select "Off" or "On" to turn the PIR function off or on and press the "OK" button.

NOTE: If multiple cameras are paired to the monitor then select the desired camera.

3. The monitor will connect to the desired camera.

4. Press the "OK" button to confirm.

NOTE: A single beep from the camera indicates motion detection has been turned OFF.

A triple beep indicates motion detection has been turned ON.

Backlight time:

1. Select "Backlight time" and press the "OK" button.
2. Use the "Up" or "Down" buttons to select a backlight time between 10~60 seconds.
3. Press the "OK" button to confirm.

Installation – Monitor (continued):

Recharge the monitor battery:

There are two ways to recharge the monitor battery.

1. Place the monitor into the monitor charger stand and plug the charger into the stand.
2. Plug the charger directly into the monitor.

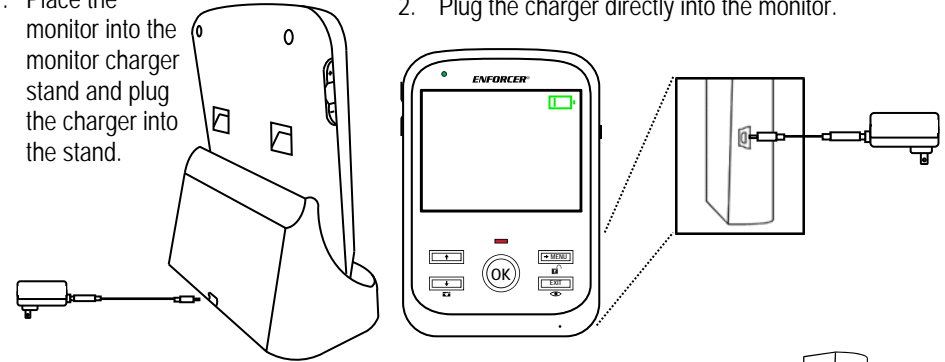

Turn monitor ON:

Hold the "ON/OFF" button for 3 seconds. The monitor will turn ON with the ENFORCER screen.

Standby mode:

If the display is OFF, press the "ON/OFF" button momentarily to leave standby mode and turn the display ON. The red indicator LED will flash once every three seconds in standby mode.

Low battery:

When the battery is low (indicated by 1 or 0 bars on the display's battery icon), the red indicator LED will start to flash once per second.

Turn monitor OFF:

While the monitor's display is ON, hold the "ON/OFF" button for 3 seconds and the Shutdown menu will come up. Select "YES" to turn the monitor OFF.

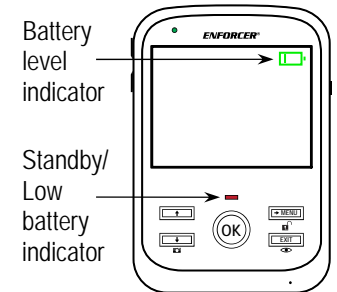
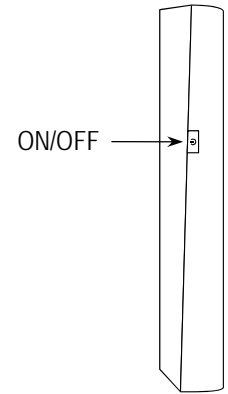

On-Screen Display Features:



- Photos** – View and delete photos taken by the camera station. There are four different types of photos
- M – Photos taken by the user manually (1 photo taken).
 - A – Photos taken by the camera station automatically when the doorbell button is pressed (1 photo taken).
 - T – Photos taken by the camera station automatically when the unit is removed from the bracket and the tamper alarm activates (4 photos taken).
 - P – Photos taken by the camera station automatically when the PIR function is activated (3 photos taken).



- Messages** – View photos from missed calls, same as "Automatic" photos.



- Time** – Set the time and date.



- Ring** – Choose from four different ring tones (Telephone, Doorbell, Für Elise, or Jingle Bells) and set ring volume (six volume levels).



- Language** – Choose from English, German, Spanish, French, Russian, or Chinese language formats.



- Setup** – Set advanced settings such as Motion detection, Backlight time, Unlocking duration, Pairing, Alarm settings, or Version information.

Programming and Using the On-Screen Display:

1. While the monitor display is on, press the "Menu/Unlock" button to open the on-screen display.
2. Use the "Up" and "Down" buttons to move the cursor up or down. Use the "Menu/Unlock" button to move the cursor to the right.
3. To select a Menu option, highlight the option and press the "OK" button.
4. To exit the on-screen display, press the "Exit" button.

NOTE: If there is no activity, the monitor will exit programming mode and the display will turn off in 35 seconds.

Viewing and deleting photos:

1. While the monitor display is on, press the "Menu/Unlock" button to open the on-screen display.
2. Highlight the "Photo" icon and press the "OK" button to enter the "Photo" screen.
3. Use the "Up" and "Down" buttons to select the photo to be viewed.
 - NOTE:** Photos are saved with the following format: "X-HHMMSS-YYMMDD.jpg" with "X" being the type of photo, "HHMMSS" being the time the photo was taken, and "YYMMDD" being the date the photo was taken.
4. Press the "OK" button and select from "View," "Delete," or "Delete All."
 - a. Press "View" to view a photo.
 - b. Press "Delete" to delete the selected photo (after an additional prompt).
 - c. Press "Delete All" to delete all photos (after an additional prompt).
5. Once viewing a photo, press the "Up" or "Down" buttons to cycle through other photos.
6. Press the "OK" button to either delete or exit the photo viewing mode and go back to the on-screen display menu.

NOTE: The monitor can save up to 240 photos. Photos are saved in a "first-in, first-out" method, meaning that the system automatically deletes the oldest photo.

NOTE: There is no way to export any of the photos on the device.

Viewing and deleting messages:

1. While the monitor display is on, press the "Menu/Unlock" button to open the on-screen display.
2. Highlight the "Messages" icon and press the "OK" button to enter the "Messages" screen.
3. Use the "Up" and "Down" buttons to select the message to be viewed.
 - NOTE:** Messages are the same as Automatic photos but are saved with the following format: "HH:MM:SS MM-DD-YYYY."
4. Press the "OK" button and select from "Open," "Delete," or "Delete All."
 - a. Press "Open" to view a message.
 - b. Press "Delete" to delete the selected message (after an additional prompt).
 - c. Press "Delete All" to delete all messages (after an additional prompt).
5. Once viewing a message, press the "OK" button to return to the "Messages" screen.

NOTE: The monitor can save up to 10 messages. Messages are saved in a "first-in, first-out" method, meaning that the system automatically deletes the oldest message.

NOTE: Messages will not be saved if the indoor monitor is off.