



TEST REPORT

REGULATION : **FCC Part 22, 74, 80, 90**
RSS-119 Issue 12

Applicant	Testing Laboratory
JVCKENWOOD Corporation 1-16-2, Hakusan, Midori-ku, Yokohama-shi Kanagawa, 226-8525 Japan Tel.: +81 45 939 6254 Fax.: +81 45 939 6261	Intertek Japan K.K. Kashima Laboratory URL: http://www.japan.intertek-etlsemko.com (No.12 Test site) 298-6 Sada, Kashima, Ibaraki 314-0027 Japan Tel. +81 299 82 8464

Equipment type	VHF REPEATER
Trademark	KENWOOD
FCC Model(s)	NXR-1700-E
HVIN (ISED)	NXR-1700-E
PMN (ISED)	NXR-1700-E
Serial No.	001
FCC ID	K44513100
ISED CN and UPN	282F-513100
Test Result	Complied
Report Number	21120486JKA-002
Original Issue Date	February 03, 2022

This report is for the exclusive use of Intertek's Client and is provided pursuant to the agreement between Intertek and its Client. Intertek's responsibility and liability are limited to the terms and conditions of the agreement. Intertek assumes no liability to any party, other than to the Client in accordance with the agreement, for any loss, expense or damage occasioned by the use of this report. Only the Client is authorized to permit copying or distribution of this report and then only in its entirety. Any use of the Intertek name or one of its marks for the sale or advertisement of the tested material, product or service must first be approved in writing by Intertek. The observations and test results in this report are relevant only to the sample tested. This report by itself does not imply that the material, product, or service is or has ever been under an Intertek certification program.

Approved by

Tested by

Hideaki Kosemura
[Technical Manager]

Koichi Wagatsuma
[Engineer]



The report must not be used by the client to claim product certification, approval, or endorsement by NVLAP, NIST, or any agency of the U.S. Government.

*NVLAP accreditation are valid for RSS-119.
 FCC Part90, FCC Part80, FCC Part74 and FCC Part22 are outside the NVLAP scope.
 This report contains data that are not covered by the NVLAP accreditation.*



*VLAC accreditation are valid for FCC Part90, FCC Part80, FCC Part74 and FCC Part22.
 RSS-119 are outside the VLAC scope.
 This report contains data that are not covered by the VLAC accreditation.*

In Accordance with FCC Rules and Regulations, Volume II, Part 2 and 90

Sub-part 2.1033

Applicant and Manufacture Information	
APPLICANT	
Company	: JVCKENWOOD Corporation
Address	: 1-16-2, Hakusan, Midori-ku, Yokohama-shi Kanagawa, 226-8525 Japan
Contact Person	: Tamaki Shimamura
MANUFACTURER	
Company	: JVCKENWOOD Corporation
Address	: 1-16-2, Hakusan, Midori-ku, Yokohama-shi Kanagawa, 226-8525 Japan
(c)(2) FCC ID	
FCC ID	: K44513100
Model number	: NXR-1700-E
Serial number	: 001
Instruction Manual(S)	
Instruction manual(s)	: Please refer to attached Exhibits F
Type of Emission	
Emission Designation	: 16K0F3E(Wide) 11K0F3E(Narrow) 7K60FXD(Narrow) / 7K60FXE(Narrow) / 7K60F7E(Narrow) / 7K60F7D(Narrow) / 7K60F7W(Narrow) / 7K60FXW(Narrow) 8K30F1E(Narrow) / 8K30F1D(Narrow) / 8K30F7W(Narrow) 4K00F1E(Very Narrow) / 4K00F1D(Very Narrow) / 4K00F7W(Very Narrow) 4K00F2D(Very Narrow)
Frequency range	
Frequency Range	: 150 to 174 MHz 138 to 144 MHz, 148 to 174 MHz
Power Rating	
Output Power	: 1 to 50 W
Type	: Continuously Variable
Maximum Power Rating	
Output Power	: 50 W
Voltages & currents in all elements in final RF stage, including final transistor or solid-state device	
Collector Current, A	: 11.0 A Maximum
Collector Voltage, Vdc	: 13.2Vdc (10.8 to 15.6 Vdc)
Supply Voltage, Vdc	: 13.2 Vdc
Other Information	
Number of Channel	: 32 channels
Maximum Deviation	: ± 5 kHz (16K0F3E),
Frequency Stability	: 0.5 ppm
Antenna Impedance	: 50 Ω Norminal
Note	
This information was provided by the Applicant or customer. Intertek doesn't take any responsibility for the information.	

TABLE OF CONTENTS

	Page
SECTION 1. GENERAL INFORMATION	4
SECTION 2. SUMMARY OF TEST RESULT	5
SECTION 3. TEST AND MEASUREMENT DATA	6
SECTION 4. INFORMATION ABOUT EUT AND SUPPORT EQUIPMENT(S)	7
SECTION 5. SUPPORT EQUIPMENT	7
SECTION 6. USED CABLE(S)	8
SECTION 7. TEST CONFIGURATION	9
SECTION 8. OPERATING CONDITION	10
SECTION 9. MEASUREMENT UNCERTAINTY	11
SECTION 10. TEST DATA	
10.1 Carrier Output Power (Conducted)	12
10.2 Unwanted Emissions (Transmitter Conducted)	15
10.3 Field Strength of Spurious Radiation	18
10.4 Emission Masks (Occupied Bandwidth)	22
10.5 Transient Frequency Behavior	32
10.6 Audio Frequency Response / Audio Low Pass Filter (Voice Input)	40
10.7 Modulation Limiting	45
10.8 Frequency Stability (Temperature Variation)	50
10.9 Frequency Stability (Voltage Variation)	54
10.10 Receiver Spurious Emissions(Radiated)	56
10.11 Necessary Bandwidth and Emission Bandwidth	60
10.12 99% Occupied Bandwidth	62
APPENDIX PHOTOGRAPHS	

SECTION 1. GENERAL INFORMATION

TEST PERFORMED

Location	Kashima No.12 Test Site
EUT Received	January 14, 2022
Date of Test	January 24, 2022 to January 31, 2022
Standard Applied	FCC Part 22, 74, 80, 90 RSS-119 Issue 12
Measurement Method	ANSI/TIA-603-E-2016 / RSS-119 Issue 12(2015), RSS-Gen Issue 5(2018), A2(2021) ANSI C63.26 2015
Deviation from Standard(s)	Not applicable

QUALIFICATIONS OF TESTING LABORATORY (Kashima Lab.)

ACCREDITATION	SCOPE	LAB. CODE	Remarks
VLAC	Wireless / EMC Testing	VLAC-008-1	JAPAN
NVLAP	Wireless Testing	600233-0	USA
FCC	Wireless / EMC Testing	JP0008	USA
ISED	Wireless Testing	JP0008(CABID)	Canada

ABBREVIATIONS

EUT	Equipment Under Test	DoC	Declaration of Conformity
AMN	Artificial Mains Network	ISN	Impedance Stabilization Network
LISN	Line Impedance Stabilization Network	Q-P	Quasi-peak
AMP	Amplifier	AVG	Average
ATT	Attenuator	PK	Peak
ANT	Antenna	Cal	Calibration
BBA	Broadband Antenna	N/A	Not applicable or Not available
DIP	Dipole Antenna	LCD	Liquid-Crystal Display
AE	Associated Equipment	4LEVEL FSK	4LEVEL Frequency Shift Key
GMSK	Gaussian Maximum Shift Key	CW ID	Continuously Repeating bit stream
FM	Frequency Modulation	C4FM	Constant envelope 4 Level FM
PTT	Push to Talk	AFC	Automatic frequency control

Revision Summary

Revised Date	Section	Description of Changes

SECTION 2. SUMMARY OF TEST RESULT

TEST ITEM	FCC Part22	Part74	Part80	Part90	ISED RSS-119	RESULTS	Comments
Carrier Output Power (Conducted)	-	74.461	-	-	2.1046 (a)	5.4	PASS
Unwanted Emissions (Transmitter Conducted)	22.359	-	80.211	90.210	2.1051	5.8	PASS
Field Strength of Spurious Radiation	22.359	-	80.211	90.210	2.1053 (a)	5.8	PASS
Emission Masks (Occupied Bandwidth)	22.359	74.462	80.211	90.210	2.1049 (c) (1)	5.5	PASS
Transient Frequency Behavior	-	-	-	90.214	-	5.9	PASS
Audio Low Pass Filter (Voice Input)	-	-	80.213	-	2.1047 (a)	-	PASS
Audio Frequency Response	-	-	80.213	-	2.1047 (a)	-	PASS
Modulation Limiting	-	-	80.213	-	2.1047 (b)	-	PASS
Frequency Stability (Temperature Variation)	22.355	74.464	80.209	90.213 (a)	2.1055 (a) (1)	5.3	PASS
Frequency Stability (Voltage Variation)	22.355	74.464	80.209	90.213 (a)	2.1055 (d) (1)	5.3	PASS
Receiver Spurious Emissions	-	-	-	-	-	RSS-Gen 7.1	PASS
Certification required (FCC Part 90.203(j)(3))	-	-	-	90.203 (j)(3)	-	-	Complied
Certification required (FCC Part 90.203(j)(4))	-	-	-	90.203 (j)(4)	-	-	Complied
Certification required (FCC Part 90.203(j)(5))	-	-	-	90.203 (j)(5)	-	-	Complied
Certification required (FCC Part 90.203(e))	-	-	-	90.203 (e)	-	-	Complied
99% Occupied Bandwidth	-	-	-	-	-	5.5	PASS

Limitation on Results

The test result of this report is effective equipment under test itself and under the test configuration described on the report. This test report does not assure that whether the test result taken in other testing laboratory is compatible or reproducible to the test result on this report or not.

Note:

As for the FCC Part 15 Subpart B-Unintentional Radiators, the EUT has been measured and declared as Supplier's Declaration of Conformity (SDoC) by JVCKENWOOD Corporation.

SECTION 3. TEST AND MEASUREMENT DATA

All test and measurements indicated in this document were performed in accordance with the Code of Federal Regulations Title 47 Part 2, Sub-part J and Industry Canada as the following individual parts:

FCC Rule	Test Item	Tested
Part 22	Non Cellular	YES
Part 74	Experimental Radio Auxiliary , Special Broadcast and Other Program Distributional Services	YES
Part 80	Stations in the Maritime Services	YES
Part 90	Private Land Mobile radio Services	YES

IC Rule	Test Item	Tested
RSS-119	Radio Ttransmitters and Receivers Operating in the Land Mobile and Fixed Services in the Frequency Range 27.4-960 MHz	YES
RSS-Gen	General Requirements for Compliance of Radio Apparatus	YES

SECTION 4. INFORMATION ABOUT EUT AND SUPPORT EQUIPMENT(S)

This information was provided by the Applicant or customer.
 Intertek doesn't take any responsibility for the information.

4.1 List of System Configuration

Symbol	Item	Model No.	Serial No.	Manufacture	Remarks
A	VHF REPEATER	NXR-1700-E	001	JVCKENWOOD Corporation	EUT
Power Ratings of EUT :			13.2Vdc (10.8 to 15.6 Vdc)	11.0 A Maximum	
Power Supply :			13.2 Vdc		
Condition of Equipment			Proto type		
Type			Base Fixed (Repeater)		
Suppression Devices			No Modifications by the laboratory were made to the device		

4.2 Port(s)/Connector(s)

Port Name	Connector Type	Connector Pin	Remarks
LAN	RJ-45	8pin	
ACC	USB Type-A	4 pin	
RF Antenna TX	N	2 pin	
RF Antenna RX	BNC	2 pin	
Control I/O	D-sub	25 pin	

4.3 Highest Frequency Oscillator(s)/Crystal(s)

Operating Frequency	Board Name	Remarks
219 MHz	Radio	
1500 MHz	CPU	

SECTION 5. SUPPORT EQUIPMENT

The EUT was supported by the following equipment during the test.

Example: Case of Section 10.10Test

Symbol	Item	Model No.	Serial No.	Manufacture	FCC ID	Remarks
B	USB ADAPTER	AU-MMSA	None	SABRENT	N/A	See Note
C	Terminator	None	None	JVCKENWOOD	N/A	See Note
D	Terminator	None	None	JVCKENWOOD	N/A	See Note
E	HUB	GS305-300JPS	5U81035N0037E	NETGEAR	DoC	See Note
F	AC ADAPTER	AD2015F20	3120023431072712 3X	NETGEAR	N/A	See Note
G	DC Power Supply	PMC35-3A	LE000716	KIKUSUI	N/A	
H	Terminator	DL-30N	No.1	DIAMOND ANTENNA	N/A	See Note
I	Terminator	DL-30N	No.2	DIAMOND ANTENNA	N/A	See Note
J	Controller	None	None	JVCKENWOOD	N/A	See Note

Supplied Power:

F, G	AC	100V,60Hz
------	----	-----------

Note: This information was provided by the Applicant or customer.
 Intertek doesn't take any responsibility for the information.

SECTION 6. USED CABLE(S)

The following cable(s) was used for the test.

Example: Case of Section 10.10Test

No.	Name	Length (m)	Shield	Metal		Remarks
				Connector	Ferrite core	
1	LAN cable	2.00	No	No		See Note
2	D-Sub cable	1.60	Yes	Yes		See Note
3	USB cable	2.00	Yes	Yes		See Note
4	Power cable for EUT (DC)	4.00	No	No		See Note
5	Power cable for HUB (DC)	1.10	No	No	Removable x 2	See Note
6	Power cable for DC Power Supply (AC)	1.00	No	No		

Note: This information was provided by the Applicant or customer.
 Intertek doesn't take any responsibility for the information.
 Two Ferrite cores of No.5 cable is supplied together with HUB(E).

SECTION 7. TEST CONFIGURATION

Details of Configuration and Connection

Example: Case of Section 10.10Test

- * : EUT
- : Joint Connector
- : Ferrite core

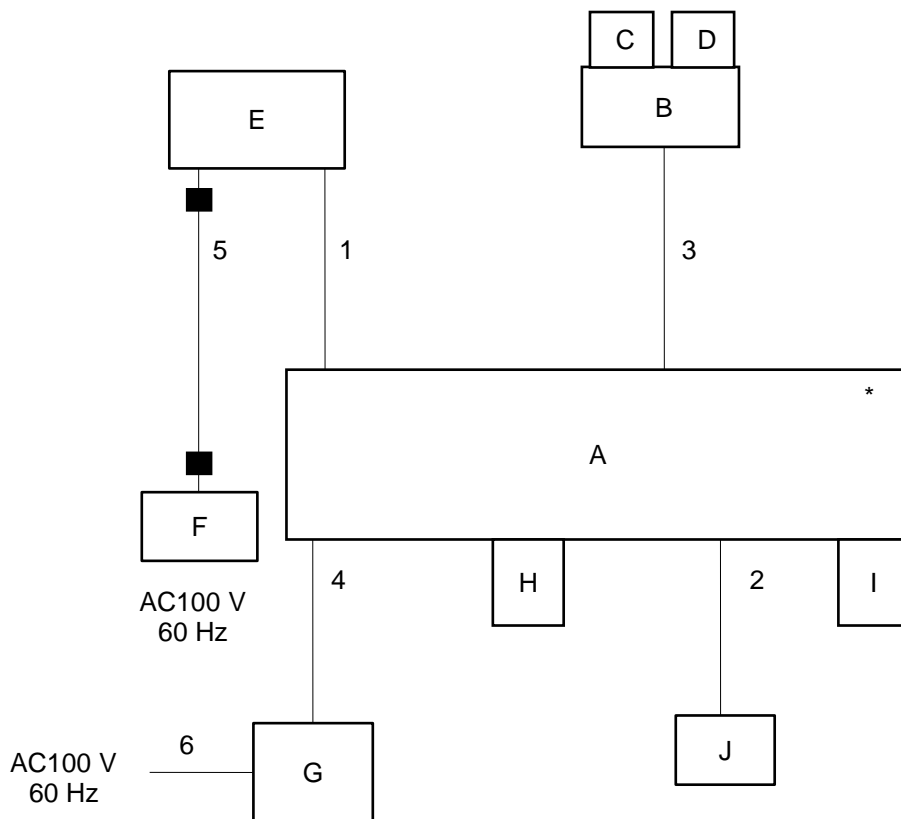

SECTION 8. OPERATING CONDITION

The EUT was operated under the following condition during the test.

8.1 Operating Condition

The test was carried out under Transmit mode.
(FCC: 150.05 MHz, 162.05 MHz, 173.95 MHz)
(RSS: 138.05 MHz, 162.05 MHz, 173.95 MHz)
(High Power : 50W, Low Power : 1W)

The test was carried out under Receive mode.
(138.05 MHz, 162.05 MHz, 173.95 MHz)
EUT was examined in the operating conditions that had maximum emissions.

8.2 Operating Flow [Transmit mode]

Following operations were performed continuously.

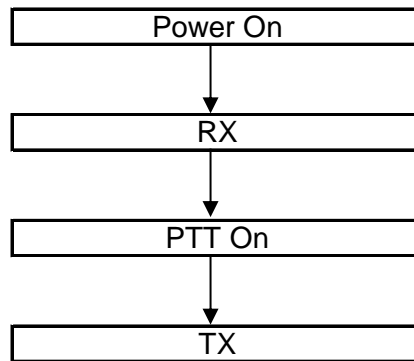

8.3 Operating Flow [Receive mode]

Following operations were performed continuously.

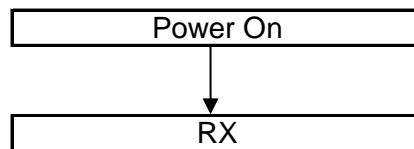

SECTION 9. MEASUREMENT UNCERTAINTY

Carrier Output Power (Conducted)	U _{lab}	Utia-603-e
	+/- 0.18dB (k = 2)	+/- 0.59 dB
Unwanted Emissions (Transmitter Conducted)		
	+/- 1.55 dB (k = 2)	+/- 1.1 dB
Field Strength of Spurious Radiation		
	+/- 3.90dB (k = 2)	+/- 3.3 dB
Emission Masks (Occupied Bandwidth)		
	+/- 0.87dB (k = 2)	+/- 2.1 dB
Transient Frequency Behavior		
	+/- 2.28% (k = 2)	+/- 21.6 %
Audio Low Pass Filter (Voice Input)		
	+/- 0.21dB (k = 2)	+/- 1.2 dB
Audio Frequency Response		
	+/- 0.12dB (k = 2)	+/- 1.2 dB
Modulation Limiting		
	+/- 0.99% (k = 2)	+/- 1.0 %
Frequency Stability (Temperature Variation)		
	+/- 9.93Hz (k=2)	+/-34.2 Hz
Frequency Stability (Voltage Variation)		
	+/- 9.93Hz (k=2)	+/-34.2 Hz
Receiver Spurious Emissions	U _{lab}	Ucispr
30-1000MHz	+/- 4.58dB (k = 2)	+/- 6.3 dB
abobe 1GHz	+/- 5.12dB (k = 2)	+/- 5.2 dB
Bandwidth		
	+/- 1.00% (k = 2)	-

SECTION 10. TEST DATA

10.1 Carrier Output Power (Conducted)

REGULATIONS	: FCC Part 2 Section 1046 (a) RSS-119 Section 5.4
TEST METHOD/GUIDE	: ANSI/TIA-603-E Section 2.2.1.2 / RSS-119 Section 4.1 ANSI C63.26 Section 5.2

Test Procedure

- The EUT and test equipment were set up as shown on the following page.
- The EUT was conducted to a resistive coaxial attenuator of normal load impedance.
 $RF\ Power\ (dBm) = Power\ Meter\ reading\ (dBm) + Attenuator\ Loss\ (dB) + Cable\ Loss\ (dB)$
 $RF\ Power\ (W) = 10^{(RF\ Power\ (dBm)/10)}/1000$
- Modulate the transmitter with a 2.5 kHz sine wave at an input Level of 16 dB greater than that necessary to produce 50 % of rated system deviation.(Only as for the test of RSS)

Measuring Equipments

No.	Equipment	Manufacture	Model No.	Serial No.	Cal. Interval	Effective period
1	Power Meter	Hewlett Packard	E4418B	GB38410265	1Y	Aug. 31, 22
2	Power Sensor	Hewlett Packard	8482A	US37292237	1Y	Aug. 31, 22
3	Attenuator (20dB)	Aeroflex/Wenshel	66-20-34	BY4357	1Y	Sep. 30, 22
4	Attenuator (30dB)	Weinschel	WA-29-30-34	8923	1Y	Sep. 30, 22
5	Modulation	Hewlett Packard	8901B	3403A04852	1Y	Dec. 31, 22
6	Audio Generator	Anritsu	MG443B	M70150	1Y	Jun. 30, 22
7	DC Power Supply	Daiichi denpa kogyo	GZV4000	90290931	None	None
8	Digital Multi Meter	FLUKE	8846A	9642018	1Y	Jun. 30, 22
9	JIG	Hewlett Packard	ProBook 430 G3	PJPNYOKL01 47	None	None

Measuring Cables

No.	Cable	Manufacturer	Model No.	Serial No.	Cal. Interval	Effective period
W2	Balance Cable	Nicoon	3D-2V	KSR00092	1Y	Sep. 30, 22
W3	Coaxial Cable	Pacific custom	RG-58 C/U	AM90C04	1Y	Mar. 31, 22

Measuring Equipment Configuration

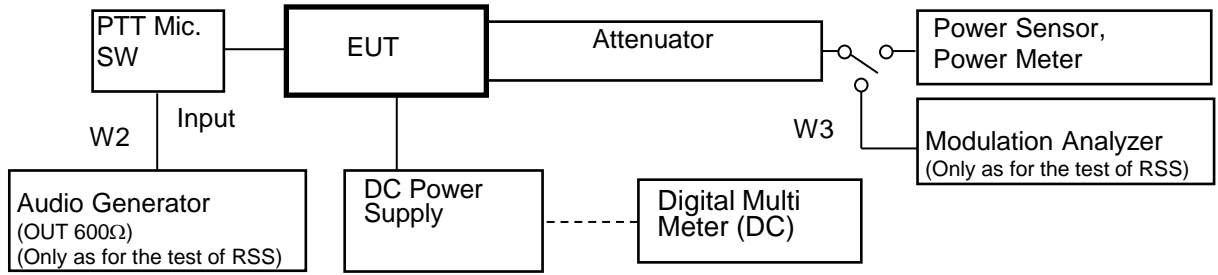

<NXDN and CW ID Modulation Case>

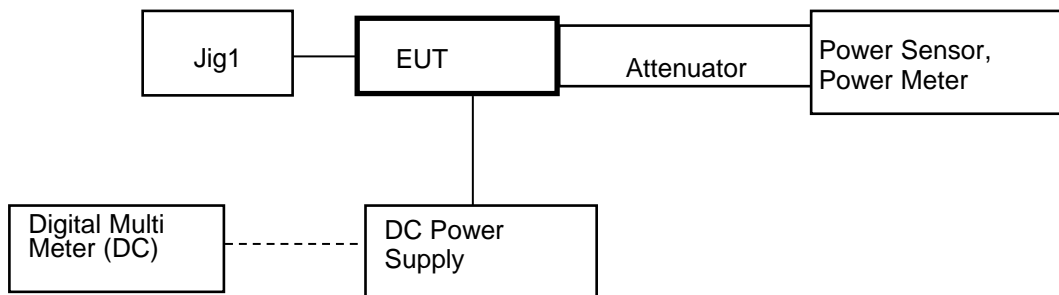

Test Results

Test date	Jan. 24, 2022	
Location	Kashima No.12 Test Site	
temperature	23.3	[degree C]
Humidity Variation	50.0	[%]
Atmospheric Pressure	100.9	[kPa]
Test Engineer	Koichi Wagatsuma	

Test was carried out for all the Authorized Bandwidth.
 State the worst case (below).

No.	Frequency (MHz)	Band	Setting	RF Power (W)
1	138.05 (RSS)	Low	High Power	50
2	150.05 (FCC)	Low	High Power	50
3	162.05 (FCC/RSS)	Middle	High Power	50
4	173.95 (FCC/RSS)	High	High Power	50
5	138.05 (RSS)	Low	Low Power	1
6	150.05 (FCC)	Low	Low Power	1
7	162.05 (FCC/RSS)	Middle	Low Power	1
8	173.95 (FCC/RSS)	High	Low Power	1

RF Power: Maximum reading

10.2 Unwanted Emissions (Transmitter Conducted)

REGULATIONS	: FCC Part 2 Section 1051, Part 22 Section 359, Part 80 Section 211, Part 90 Section 210 RSS-119 Section 5.8
TEST METHOD/GUIDE	: ANSI/TIA-603-E Section 2.2.13.2 ANSI C63.26 Section 5.7

Test Procedure

- 1 The EUT and test equipment were set up as shown on the following page.
- 2 Modulate the transmitter with a 2.5 kHz sine wave at an input Level of 16 dB greater than that than necessary to produce 50 % of rated system deviation.
- 3 Adjust the spectrum analyzer for the following setting:
 - a) RBW : 100 kHz (< 1 GHz), 1 MHz (> 1 GHz).
 - b) VBW : 300 kHz (< 1 GHz), 3 MHz (> 1 GHz).
 - c) Detector mode : Average power (FM Modulation) , Positive peak with peak hold (Digital Modulation)
- 4 The emissions were measured for the worst case as follows:
 - a) : within a band of frequencies defined by the carrier frequency plus and minus one channel.
 - b) : from the lowest frequency generated in the EUT and to at least the 10th harmonic of the carrier frequency, or 40 GHz, whichever is lower.

Measuring Equipments

No.	Equipment	Manufacture	Model No.	Serial No.	Cal. Interval	Effective period
1	Attenuator (20dB)	Aeroflex/Wenshel	66-20-34	BY4357	1Y	Sep. 30, 22
2	Attenuator (30dB)	Weinschel	WA-29-30-34	8923	1Y	Sep. 30, 22
3	Highpass Filter	Anritsu	MP526B	6200220636	1Y	Mar. 31, 22
4	Modulation Analyzer	Hewlett Packard	8901B	3403A04852	1Y	Dec. 31, 22
5	Signal Generator	Rohde&Schwarz	SMB 100A	105709	1Y	May. 31, 22
6	Audio Generator	Anritsu	MG443B	M70150	1Y	Jun. 30, 22
7	Spectrum Analyzer	Agilent	N9030A	US51350220	1Y	Sep. 30, 22
8	DC Power Supply	Daiichi denpa kogyo	GZV4000	90290931	None	None
9	Digital Multi Meter	FLUKE	8846A	9642018	1Y	Jun. 30, 22
10	JIG	HP	ProBook 430 G3	PJPNYOKL0147	None	None

Measuring Cables

No.	Cable	Manufacture	Model No.	Serial No.	Cal. Interval	Effective period
W3	Balance Cable	Nicoon	3D-2V	KSR00092	1Y	Sep. 30, 22
W4	Coaxial Cable	Pacific custom	RG-58 C/U	AM90C04	1Y	Mar. 31, 22
W2	Coaxial Cable	Suhner	SUCOFLEX104	F0000019	1Y	Mar. 31, 22

Measuring Equipment Configuration

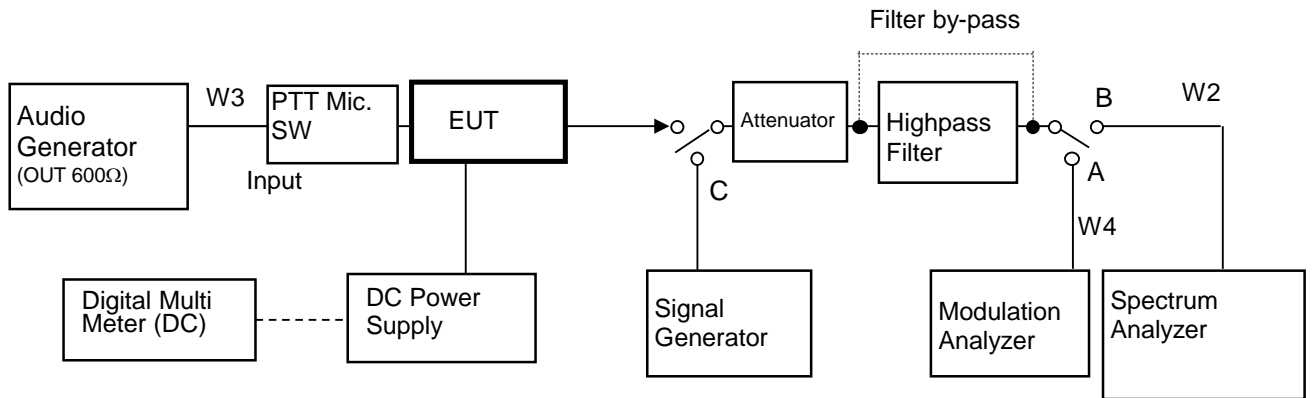

Note: Configuration of other Modulation test is composed without the Audio Generator.

<NXDN and CW ID Modulation Case>

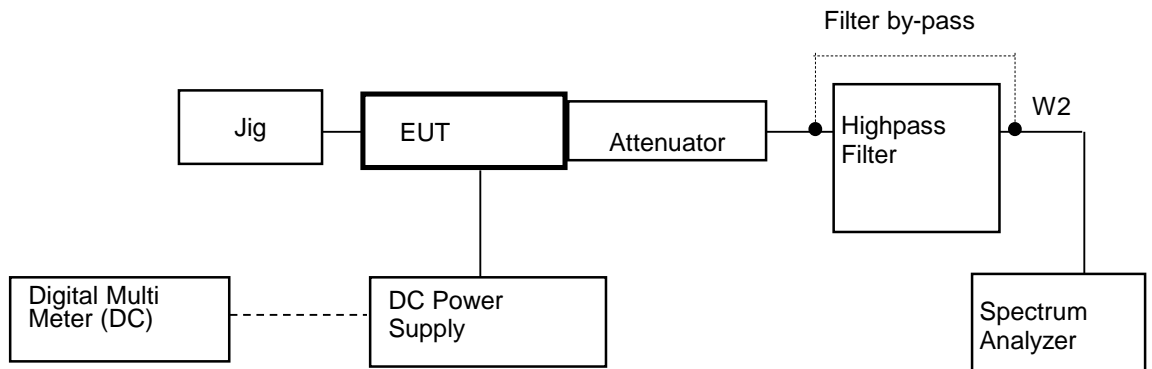

Test Results

Test date	Jan. 27, 2022
Location	Kashima No.12 Test Site
temperature	23 [degree C]
Humidity Variation	44 [%]
Atmospheric Pressure	101.2 [kPa]
Test Engineer	Koichi Wagatsuma

Test was carried out for all the frequency band of section 10.1
 State the worst case (below).

State : High Power / Authorized Bandwidth 11.25 kHz (7K60FXD/FXE/F7E/F7D/F7W/FXW)

No.	Tuned Frequency (MHz)	Band	Spurious Frequency (MHz)	Correct Level (dBm)	Emission Level (dBc)	Mask D Limit (dBc)	Margin (dB)
1	138.05 (RSS)	Low	276.10	-33.05	-80.04	-67.0	13.0
2	150.05 (FCC)	Low	300.10	-36.09	-83.08	-67.0	16.1
3	162.05 (FCC/RSS)	Middle	486.15	-35.60	-82.59	-67.0	15.6
4	173.95 (FCC/RSS)	High	347.90	-32.98	-79.97	-67.0	13.0

There is the margin of 20dB over except for the above points.

Mask D Limit (dBc) = $-(50+10\log(P))$
 Correct Level (dBm) = Substitute SG Level (dBm)
 Emission Level (dBc) = Correct Level (dBm) - $10\log(P*1000)$
 P = Carrier Level (W)
 " - " = Measurement Limit

State : Low Power / Authorized Bandwidth 6 kHz (4K00F1E / F1D / F7W)

No.	Tuned Frequency (MHz)	Band	Spurious Frequency (MHz)	Correct Level (dBm)	Emission Level (dBc)	Mask E Limit (dBc)	Margin (dB)
1	138.05 (RSS)	Low	414.15	-36.39	-66.39	-55.0	11.4
2	150.05 (FCC)	Low	450.15	-36.90	-66.90	-55.0	11.9
3	162.05 (FCC/RSS)	Middle	486.15	-35.52	-65.52	-55.0	10.5
4	173.95 (FCC/RSS)	High	521.85	-37.57	-67.57	-55.0	12.6

There is the margin of 20dB over except for the above points.

Mask E Limit (dBc) = whichever is the lesser attenuation ; $-(55+10\log(P))$ or -65
 Correct Level (dBm) = Substitute SG Level (dBm)
 Emission Level (dBc) = Correct Level (dBm) - $10\log(P*1000)$
 P = Carrier Level (W)
 " - " = Measurement Limit

10.3 Field Strength of Spurious Radiation

REGULATIONS	:	FCC Part 2 Section 1053 (a), Part 22 Section 359, Part 80 Section 211, Part 90 Section 210 RSS-119 Section 5.8
TEST METHOD/GUIDE	:	ANSI/TIA-603-E Section 2.2.12.2 / RSS-119 Section 4.2 ANSI C63.26 Section 5.5

Test Procedure

- 1 The EUT and test equipment were set up as shown on the following page.
- 2 Adjust the spectrum analyzer for the following setting:
 - a) RBW : 100 kHz (< 1 GHz), 1 MHz (> 1 GHz).
 - b) VBW : 300 kHz (< 1 GHz), 3 MHz (> 1 GHz).
 - c) Detector mode : Positive Peak
- 3 The transmitter was placed on a wooden turntable, and it was transmitting into non-radiating load which was also placed on the turntable.
- 4 The measurement antenna was placed at a distance of 3 meters from the EUT.
During the tests, the antenna height and polarization as well as EUT azimuth were varied in order to identify the maximum level of emissions from the EUT.
The test was performed by placing the EUT on 3-orthogonal axis.
- 5 The frequency range up to tenth harmonic of the fundamental frequency was investigated.
- 6 Remove the EUT and replace it with substitution antenna. A signal generator was connected to the substitution antenna by a non-radiating cable.
The absolute levels of the spurious emissions were measured by the substitution.
- 7 Spurious emissions in dB = 10 Log (TX power in Watts/0.001) – the absolute level

Measuring Equipments

No.	Equipment	Manufacture	Model No.	Serial No.	Cal. Interval	Effective period
1	Attenuator(10dB)	HUBER+SUHNER	6810.17B	5061	1Y	Feb. 28, 22
2	Dummy Load	TME	CT-150NP	1138693	1Y	Dec. 31, 22
3	Signal Generator	Rohde&Schwarz	SMB 100A	105709	1Y	May. 31, 22
4	Spectrum Analyzer /	Agilent	N9038A	MY51210201	1Y	Nov. 30, 22
5	D.R.G Antenna(RX)	Schwarzbeck	3115	5044	1Y	Jul. 31, 22
6	D.R.G Antenna(TX)	Schwarzbeck	3115	5045	1Y	Apr. 30, 22
7	Dipole Antenna(TX)	Schwarzbeck	UHA9105	AM0082002	2Y	Jan. 31, 23
8	Dipole Antenna(TX)	Schwarzbeck	VHA9103	C01082007	2Y	Jan. 31, 23
9	Tri-log Antenna(RX)	Schwarzbeck	VULB9168WP	126	1Y	Nov. 30, 22
10	DC Power Supply	Daiichi denpa kogyo	GZV4000	90290931	None	None
11	Digital Multi Meter	FLUKE	8846A	9642018	1Y	Jun. 30, 22
12	Amplifier	TOYO	TPA0118-30	0402	1Y	Sep. 30, 22
13	Attenuator	HUBER + SUHNER	6803.17.B	5111	1Y	Sep. 30, 22
14	Amplifier	Intertek Japan	ZX60-3018G	002	1Y	Sep. 30, 22
15	Attenuator	TAMAGAWA	CFA-01	A00040805	1Y	Sep. 30, 22
16	RF Switch	Intertek Japan	ACX-150-1	A12301501	1Y	Sep. 30, 22

Measuring Cables

No.	Cable	Manufacturer	Model No.	Serial No.	Cal. Interval	Effective period
R11	Coaxial Cable	FUJIKURA	5D-2W	R11	1Y	Sep. 30, 22
R1	Coaxial Cable	FUJIKURA	5D-2W	R1	1Y	Sep. 30, 22
R3	Coaxial Cable	FUJIKURA	10D-2W	R3	1Y	Sep. 30, 22
R5	Coaxial Cable	FUJIKURA	RG-5A/U	R5	1Y	Sep. 30, 22
R7	Coaxial Cable	MIYAZAKI	5D-2W	R7	1Y	Sep. 30, 22
R10	Coaxial Cable	FUJIKURA	5D-2W	R10	1Y	Sep. 30, 22
R13	Coaxial Cable	SUHNER	SUCOFLEX 104	229603	1Y	Sep. 30, 22
R12	Coaxial Cable	Candox	5B-048-98-98-5000	111130	1Y	Sep. 30, 22
W13	Coaxial Cable	Suhner	SUCOFLEX106	KSR00207	1Y	Feb. 28, 22

Measuring Equipment Configuration

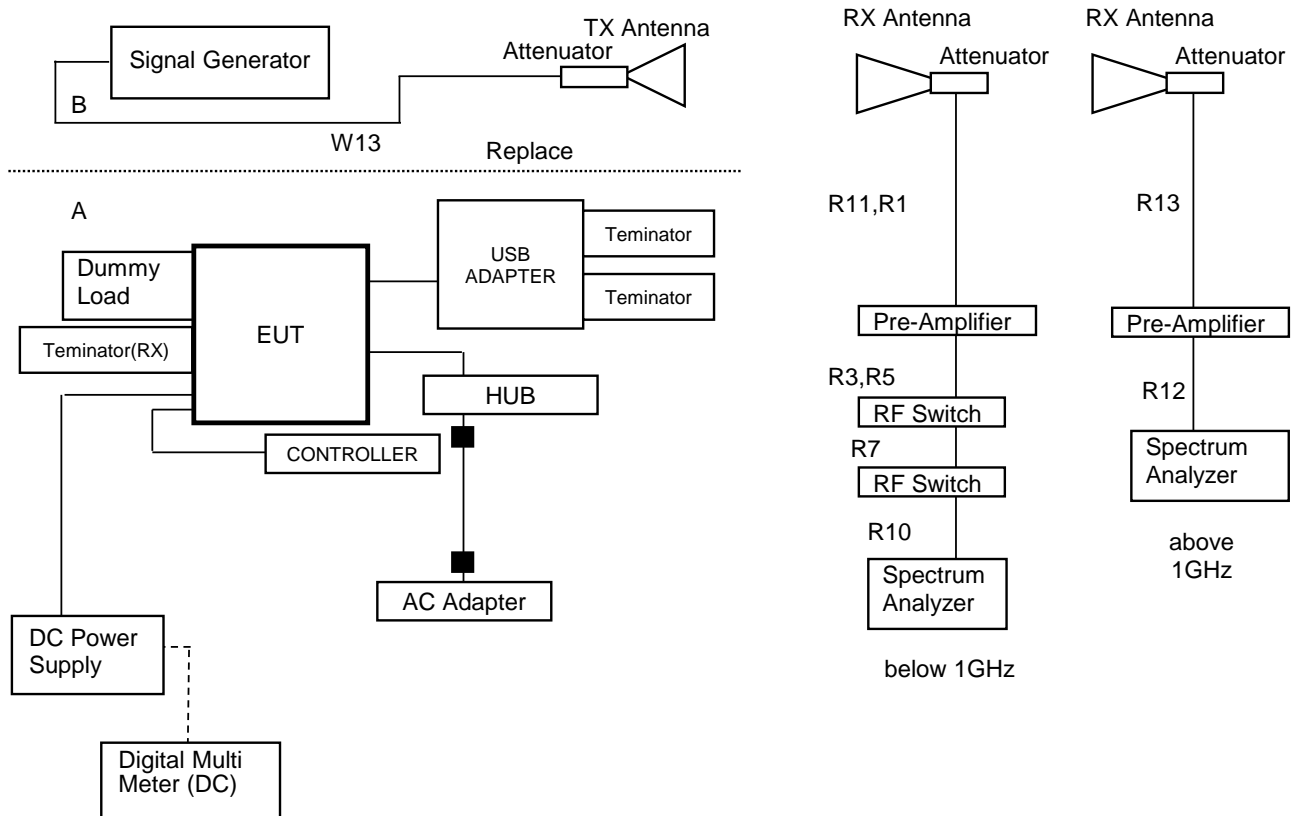

Test Results

Test date	Jan 24, 2022	to	Jan 25, 2022
Location	Kashima No.12 Test Site		
temperature	20.0 to 21.5		[degree C]
Humidity Variation	30 to 40		[%]
Atmospheric Pressure	101 to 102		[kPa]
Test Engineer	Koichi Wagatsuma		

Test was carried out for all the frequency band of section 10.1
 State the worst case (below).

State : High Power / Authorized Bandwidth 11.25 kHz / 173.95MHz(FCC /RSS)

No	Frequency (MHz)	Pol	Reading Level (dBm)	SG Out Level (dBm)	Antenna Gain (dBd)	Loss (dB)	Correct Level (dBm)	Emission Level (dBc)	MASK D Limit Level (dBc)	Margin (dB)
1	347.90	Hor.	-54.35	-34.44	-0.16	11.48	-46.1	-93.1	-67.0	26.1
		Ver.	-60.77	-36.56	-0.16	11.48	-48.2	-95.2	-67.0	28.2
2	521.85	Hor.	-52.22	-25.68	-0.91	11.83	-38.4	-85.4	-67.0	18.4
		Ver.	-56.68	-30.14	-0.91	11.83	-42.9	-89.9	-67.0	22.9
3	695.80	Hor.	-67.59	-37.78	-0.39	12.13	-50.3	-97.3	-67.0	30.3
		Ver.	-67.42	-35.82	-0.39	12.13	-48.3	-95.3	-67.0	28.3
4	869.75	Hor.	-66.42	-33.66	-1.51	12.38	-47.5	-94.5	-67.0	27.5
		Ver.	-68.20	-33.73	-1.51	12.38	-47.6	-94.6	-67.0	27.6
5	1043.70	Hor.	-42.21	-26.63	3.73	12.62	-35.5	-82.5	-67.0	15.5
		Ver.	-38.66	-23.48	3.73	12.62	-32.4	-79.4	-67.0	12.4
6	1217.65	Hor.	-57.70	-40.95	4.66	12.82	-49.1	-96.1	-67.0	29.1
		Ver.	-56.54	-40.08	4.66	12.82	-48.2	-95.2	-67.0	28.2
7	1391.60	Hor.	-58.78	-42.15	5.41	13.01	-49.7	-96.7	-67.0	29.7
		Ver.	-59.59	-43.79	5.41	13.01	-51.4	-98.4	-67.0	31.4
8	1565.55	Hor.	-58.14	-41.98	5.95	13.21	-49.2	-96.2	-67.0	29.2
		Ver.	-55.60	-38.89	5.95	13.21	-46.1	-93.1	-67.0	26.1
9	1739.50	Hor.	-54.47	-37.47	6.25	13.40	-44.6	-91.6	-67.0	24.6
		Ver.	-52.36	-34.90	6.25	13.40	-42.0	-89.0	-67.0	22.0

There is the margin of 20dB over except for the above points.

Mask D Limit (dBc) = whichever is the lesser attenuation ; $-(50+10\log(P))$ or -70
 Correct Level (dBm) = Substitute SG Level (dBm) + ANT Gain (dBd) - Loss (Cable, Attenuator) (dB)
 Emission Level (dBc) = Correct Level (dBm) - $10\log(P*1000)$
 P = Carrier Level (W)
 " - " = Measurement Limit

State : Low Power / Authorized Bandwidth 6 kHz / 173.95MHz(FCC /RSS)

No	Frequency (MHz)	Pol	Reading Level (dBm)	SG Out Level (dBm)	Antenna Gain (dBd)	Loss (dB)	Correct Level (dBm)	Emission Level (dBc)	MASK E Limit Level (dBc)	Margin (dB)
1	347.90	Hor.	-65.58	-45.67	-0.16	11.48	-57.3	-87.3	-55.0	32.3
		Ver.	-66.68	-42.47	-0.16	11.48	-54.1	-84.1	-55.0	29.1
2	521.85	Hor.	-57.86	-31.31	-0.91	11.83	-44.0	-74.0	-55.0	19.0
		Ver.	-62.00	-35.46	-0.91	11.83	-48.2	-78.2	-55.0	23.2
3	695.80	Hor.	-65.86	-36.06	-0.39	12.13	-48.6	-78.6	-55.0	23.6
		Ver.	-66.53	-34.93	-0.39	12.13	-47.5	-77.5	-55.0	22.5
4	869.75	Hor.	-69.85	-37.08	-1.51	12.38	-51.0	-81.0	-55.0	26.0
		Ver.	-69.90	-35.43	-1.51	12.38	-49.3	-79.3	-55.0	24.3
5	1043.70	Hor.	-46.94	-31.36	3.73	12.62	-40.3	-70.3	-55.0	15.3
		Ver.	-43.94	-28.76	3.73	12.62	-37.6	-67.6	-55.0	12.6
6	1217.65	Hor.	-61.00	-44.25	4.66	12.82	-52.4	-82.4	-55.0	27.4
		Ver.	-59.38	-42.93	4.66	12.82	-51.1	-81.1	-55.0	26.1
7	1391.60	Hor.	-56.22	-39.59	5.41	13.01	-47.2	-77.2	-55.0	22.2
		Ver.	-58.96	-43.16	5.41	13.01	-50.8	-80.8	-55.0	25.8
8	1565.55	Hor.	-	-	5.95	13.21	-	-	-55.0	-
		Ver.	-	-	5.95	13.21	-	-	-55.0	-
9	1739.50	Hor.	-62.05	-45.06	6.25	13.40	-52.2	-82.2	-55.0	27.2
		Ver.	-59.75	-42.29	6.25	13.40	-49.4	-79.4	-55.0	24.4

There is the margin of 20dB over except for the above points.

Mask E Limit (dBc) = whichever is the lesser attenuation ; $-(55+10\log(P))$ or -65

Correct Level (dBm) = Substitute SG Level (dBm) + ANT Gain (dBd) - Loss (Cable, Attenuator) (dB)

Emission Level (dBc) = Correct Level (dBm) - $10\log(P*1000)$

P = Carrier Level (W)

" - " = Measurement Limit

10.4 Emission Masks (Occupied Bandwidth)

REGULATIONS	: FCC Part 2 Section 1049 (c) (1), Part 22 Section 359, Part 74 Section 462, Part 80 Section 211, Part 90 Section 210 RSS-119 Section 5.8
TEST METHOD/GUIDE	: ANSI/TIA-603-E Section 2.2.11.2 / RSS-119 Section 5.8

Test Procedure

- 1 The EUT and test equipment were set up as shown on the following page.
- 2 For EUT supporting audio modulation, the audio signal generator was adjusted to the frequency of maximum response and with output level set for +/- 2.5 kHz deviation (or 50 % modulation). (FM modulation).
- 3 With level constant, the signal level was increased 16 dB.
- 4 For EUT supporting digital modulation, the digital modulation mode was operated to its maximum extent.
- 5 Adjust the spectrum analyzer for the following setting:
 - a) RBW : 100Hz (Non modulation and Authorized Band 6 kHz),
100Hz (Non modulation and Authorized Band 11.25 kHz),
300Hz (Non modulation and Authorized Band 20 kHz).
 - b) VBW : 10times the RBW (Non modulation , Authorized Band 6kHz, 11.25 kHz and 20 kHz).
 - c) RBW and VBW : 30 kHz (Non modulation(Digital Modulation)).
- 6 The occupied Bandwidth was measured with the Spectrum Analyzer controls set as shown on the test results.

The selection of Emission Mask

No.	Frequency (MHz)	Audio Filter	Channel Bandwidth (kHz)	Authorized Bandwidth (kHz)	Selection of Emission Mask	
					FCC	RSS
Emission Designation :		16K0F3E				
1	138.05 (RSS)	With	25	20	-	B
2	150.05 (FCC)	With	25	20	B	-
3	162.05 (FCC/RSS)	With	25	20	B	B
4	173.95 (FCC/RSS)	With	25	20	B	B
Emission Designation :		11K0F3E				
1	138.05 (RSS)	With	12.5	11.25	-	D
2	150.05 (FCC)	With	12.5	11.25	D	-
3	162.05 (FCC/RSS)	With	12.5	11.25	D	D
4	173.95 (FCC/RSS)	With	12.5	11.25	D	D
Emission Designation :		7K60FXD/FXE/F7E/F7D/F7W/FXW				
1	138.05 (RSS)	Without	12.5	11.25	-	D
2	150.05 (FCC)	Without	12.5	11.25	D	-
3	162.05 (FCC/RSS)	Without	12.5	11.25	D	D
4	173.95 (FCC/RSS)	Without	12.5	11.25	D	D
Emission Designation :		8K30F1E/F1D/F7W				
1	138.05 (RSS)	Without	12.5	11.25	-	D
2	150.05 (FCC)	Without	12.5	11.25	D	-
3	162.05 (FCC/RSS)	Without	12.5	11.25	D	D
4	173.95 (FCC/RSS)	Without	12.5	11.25	D	D
Emission Designation :		4K00F1E / F1D / F7W				
1	138.05 (RSS)	Without	6.25	6	-	E
2	150.05 (FCC)	Without	6.25	6	E	-
3	162.05 (FCC/RSS)	Without	6.25	6	E	E
4	173.95 (FCC/RSS)	Without	6.25	6	E	E
Emission Designation :		4K00F2D				
1	138.05 (RSS)	Without	6.25	6	-	E
2	150.05 (FCC)	Without	6.25	6	E	-
3	162.05 (FCC/RSS)	Without	6.25	6	E	E
4	173.95 (FCC/RSS)	Without	6.25	6	E	E

Measuring Equipments

No.	Equipment	Manufacture	Model No.	Serial No.	Cal. Interval	Effective period
1	Attenuator (20dB)	Aeroflex/Wenshel	66-20-34	BY4357	1Y	Sep. 30, 22
2	Attenuator (30dB)	Weinschel	WA-29-30-34	8923	1Y	Sep. 30, 22
3	Modulation Analyzer	Hewlett Packard	8901B	3403A04852	1Y	Dec. 31, 22
4	Audio Generator	Anritsu	MG443B	M70150	1Y	Jun. 30, 22
5	Spectrum Analyzer	Agilent	N9030A	US51350220	1Y	Sep. 30, 22
6	DC Power Supply	Daiichi denpa kogyo	GZV4000	90290931	None	None
7	Digital Multi Meter	FLUKE	8846A	9642018	1Y	Jun. 30, 22
8	JIG	HP	ProBook 430 G3	PJPNYOKL0147	None	None

Measuring Cables

No.	Cable	Manufacture	Model No.	Serial No.	Cal. Interval	Effective period
W3	Balance Cable	Nicoon	3D-2V	KSR00092	1Y	Sep. 30, 22
W4	Coaxial Cable	Pacific custom	RG-58 C/U	AM90C04	1Y	Mar. 31, 22
W2	Coaxial Cable	Suhner	SUCOFLEX104	F0000019	1Y	Mar. 31, 22

Measuring Equipment Configuration

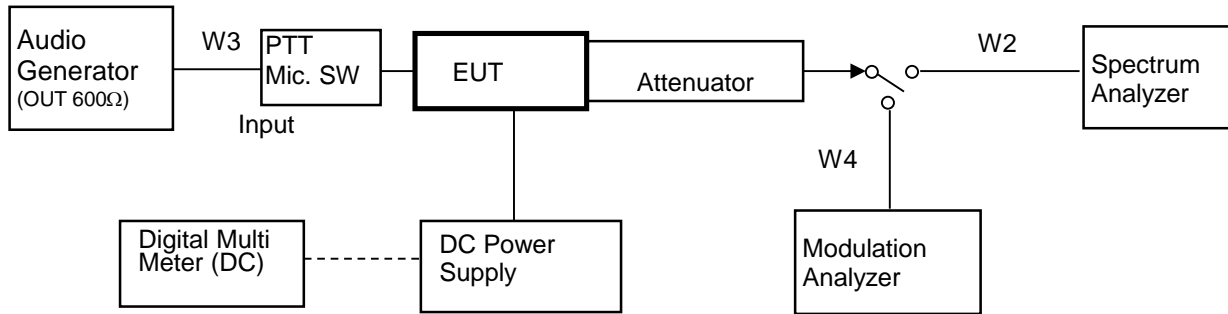

FM Modulation test is with the the Audio Generator.
Configuration of other Modulation test is composed without the Audio Generator.

<NXDN and CW ID Modulation Case>

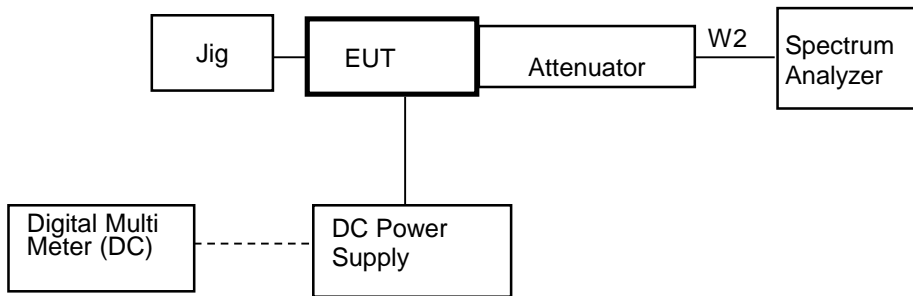

Test Results

Test date	Jan. 27, 2022	
Location	Kashima No.12 Test Site	
temperature	24.3	[degree C]
Humidity Variation	45	[%]
Atmospheric Pressure	101.4	[kPa]
Test Engineer	Koichi Wagatsuma	

Test was carried out for all the frequency band of section 10.1
 State the worst case (below).

State : High Power / Authorized Bandwidth 20 kHz/ 16K0F3E / 162.05 MHz(FCC/RSS)
 Limit : Mask B

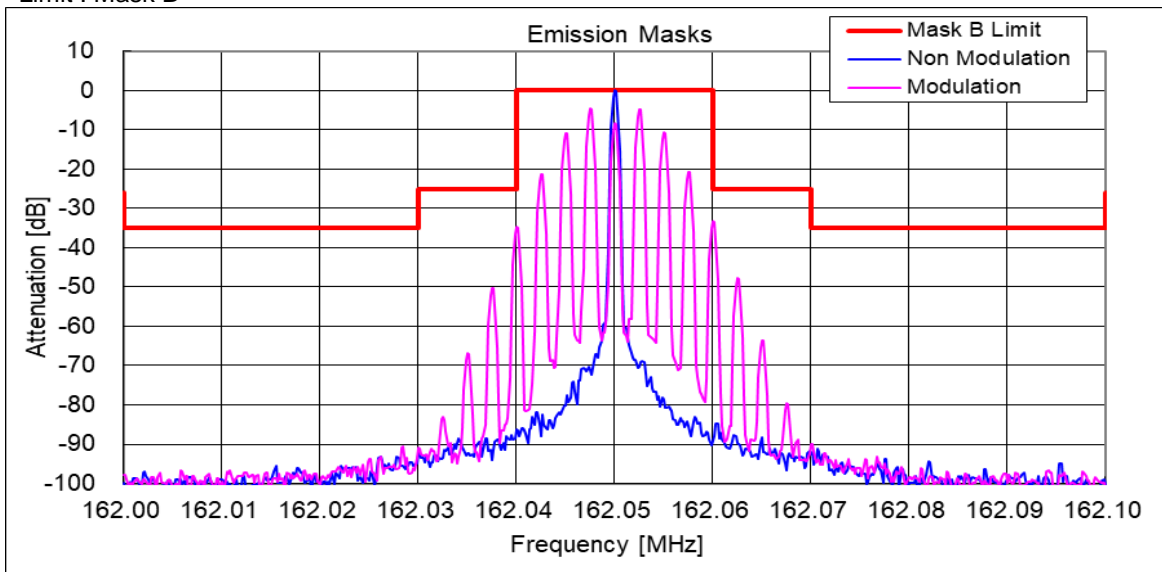

State : Low Power / Authorized Bandwidth 20 kHz/ 16K0F3E / 162.05 MHz(FCC/RSS)
 Limit : Mask B

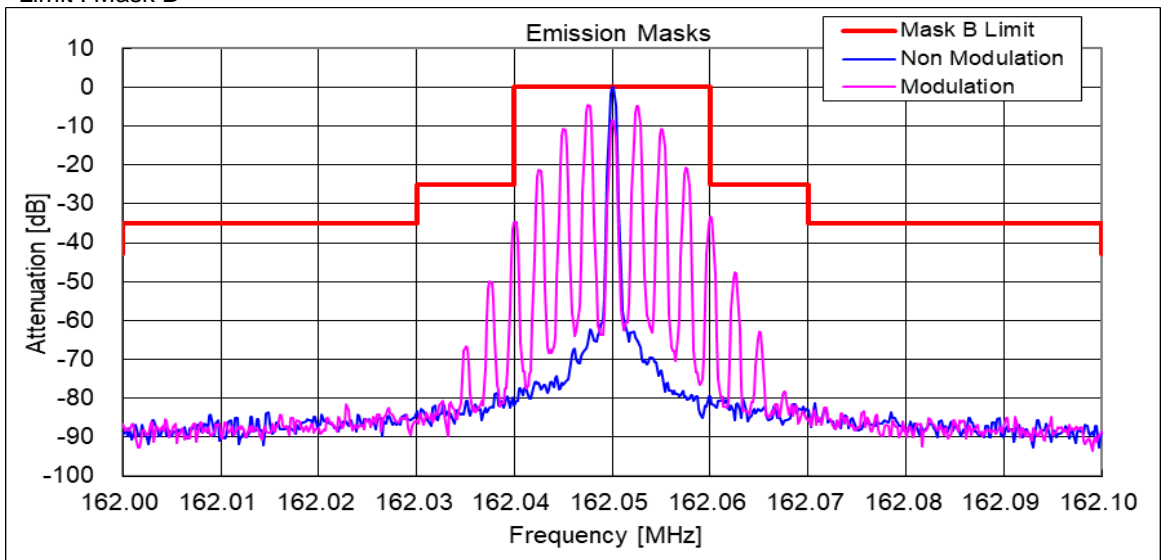

State : High Power / Authorized Bandwidth 11.25 kHz/ 11K0F3E / 173.95 MHz(FCC/RSS)
Limit : Mask D

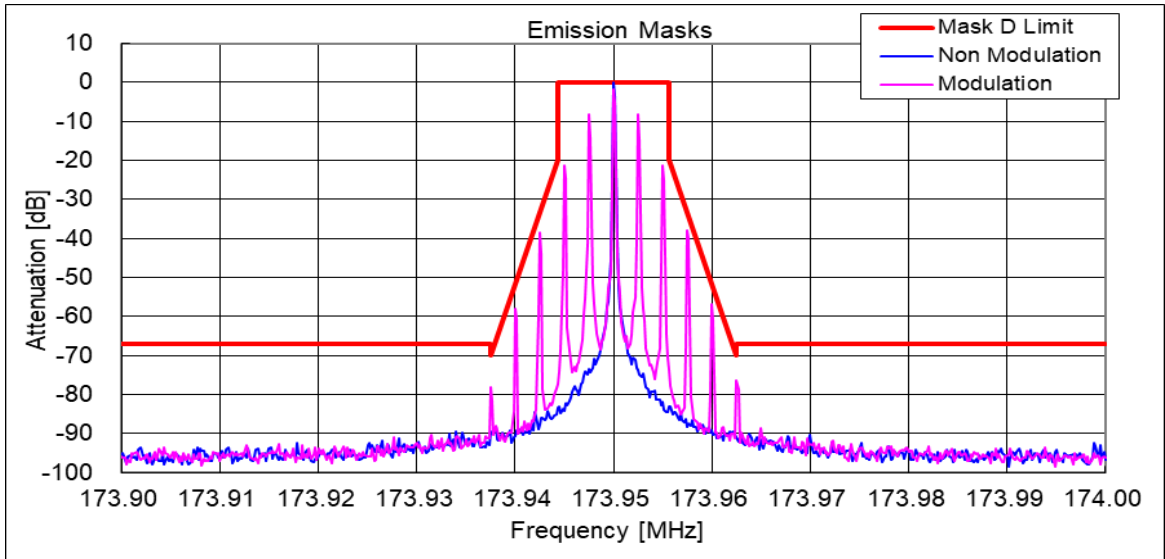

State : Low Power / Authorized Bandwidth 11.25 kHz/ 11K0F3E / 173.95 MHz(FCC/RSS)
Limit : Mask D

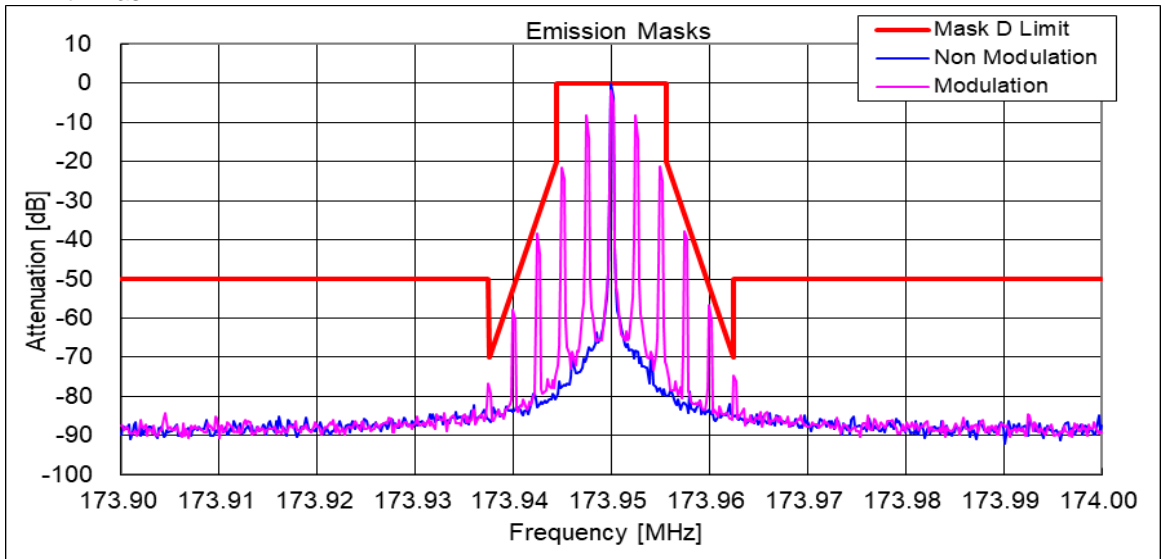

State : High Power / Authorized Bandwidth 11.25 kHz/ 7K60FXD / FXE / F7E / F7D / F7W / FXW / 173.95 MHz(FCC/RSS)
Limit : Mask D

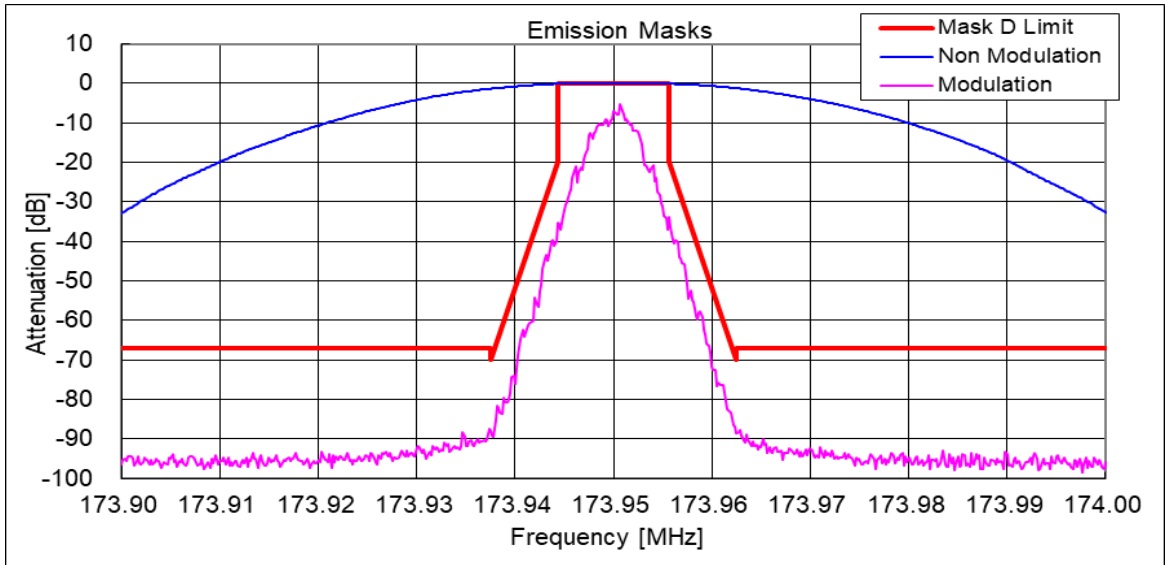

State : Low Power / Authorized Bandwidth 11.25 kHz/ 7K60FXD / FXE / F7E / F7D / F7W / FXW / 162.05 MHz(FCC/RSS)
Limit : Mask D

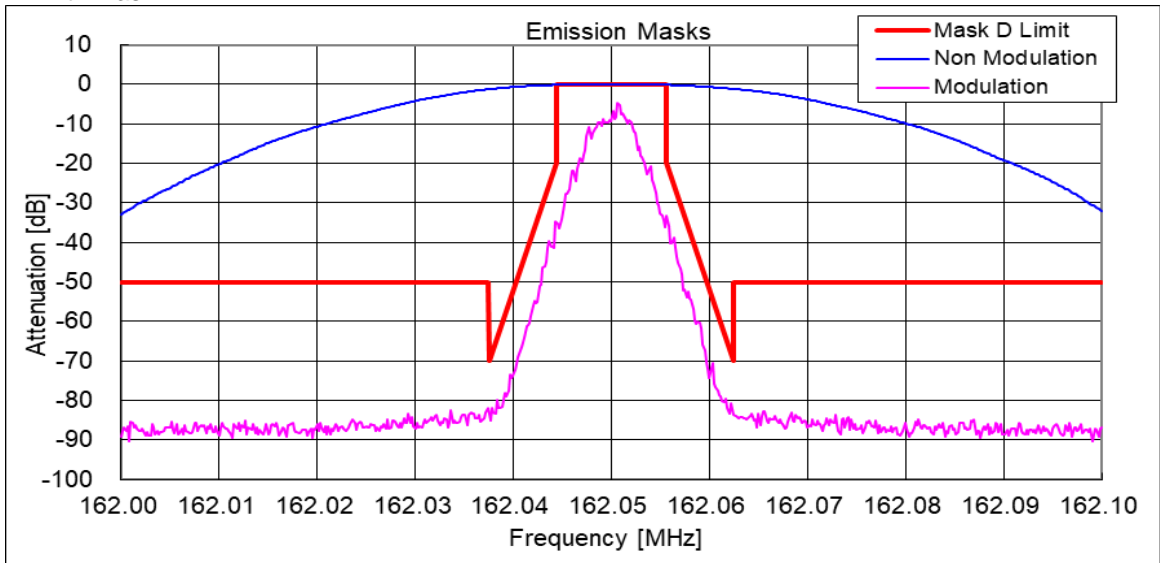

State : High Power / Authorized Bandwidth 11.25 kHz/ 8K30F1E / F1D / F7W / 173.95 MHz(FCC/RSS)
Limit : Mask D

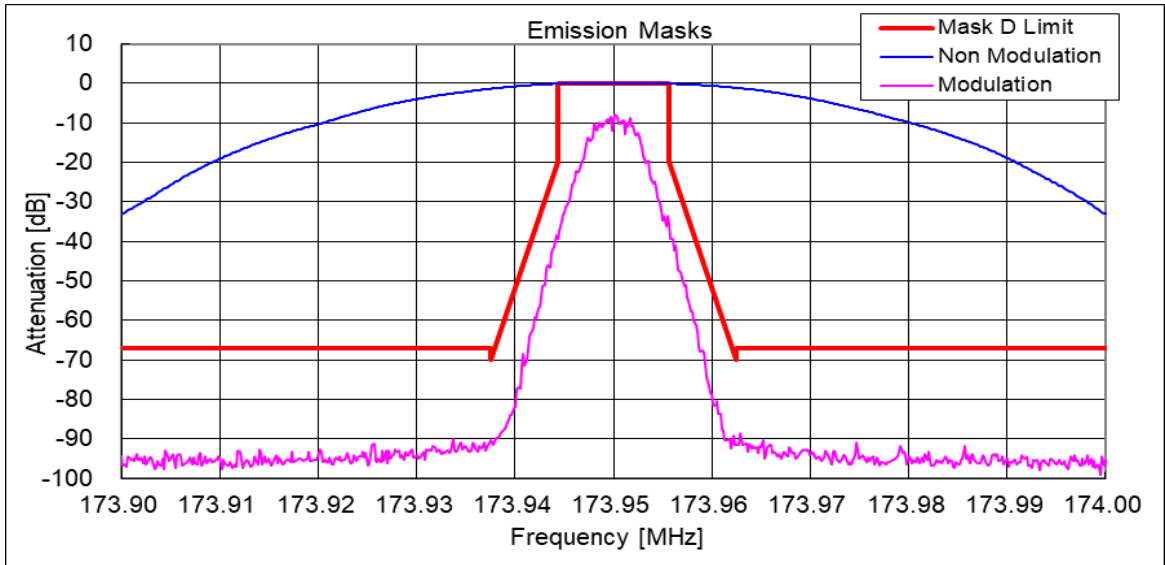

State : Low Power / Authorized Bandwidth 11.25 kHz/ 8K30F1E / F1D / F7W / 173.95 MHz(FCC/RSS)
Limit : Mask D

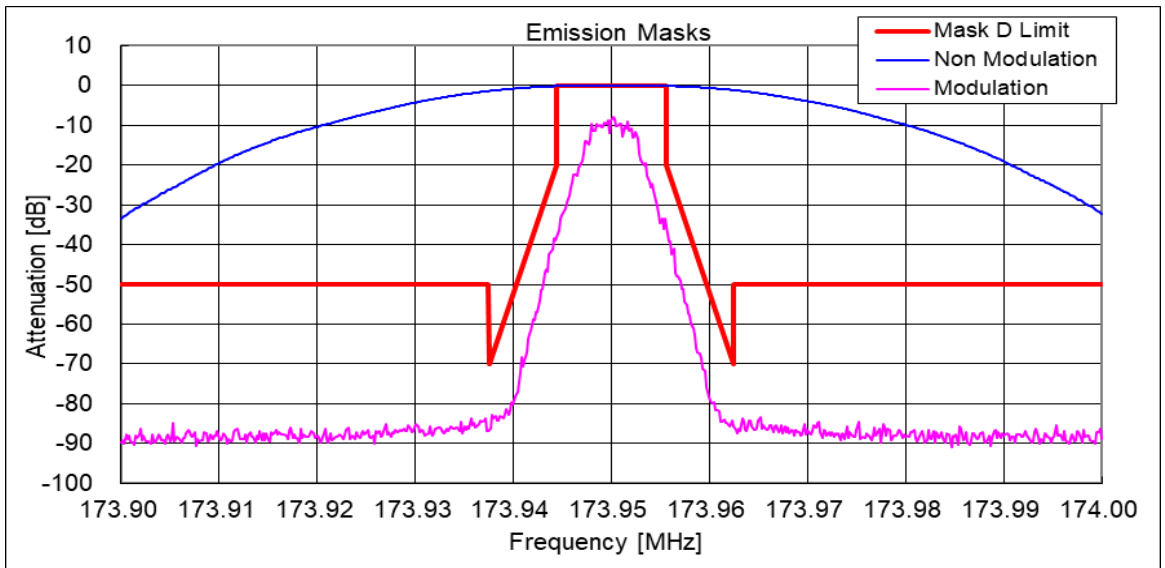

State : High Power / Authorized Bandwidth 6 kHz/ 4K00F1E / F1D / F7W / 162.05 MHz(FCC/RSS)
Limit : Mask E

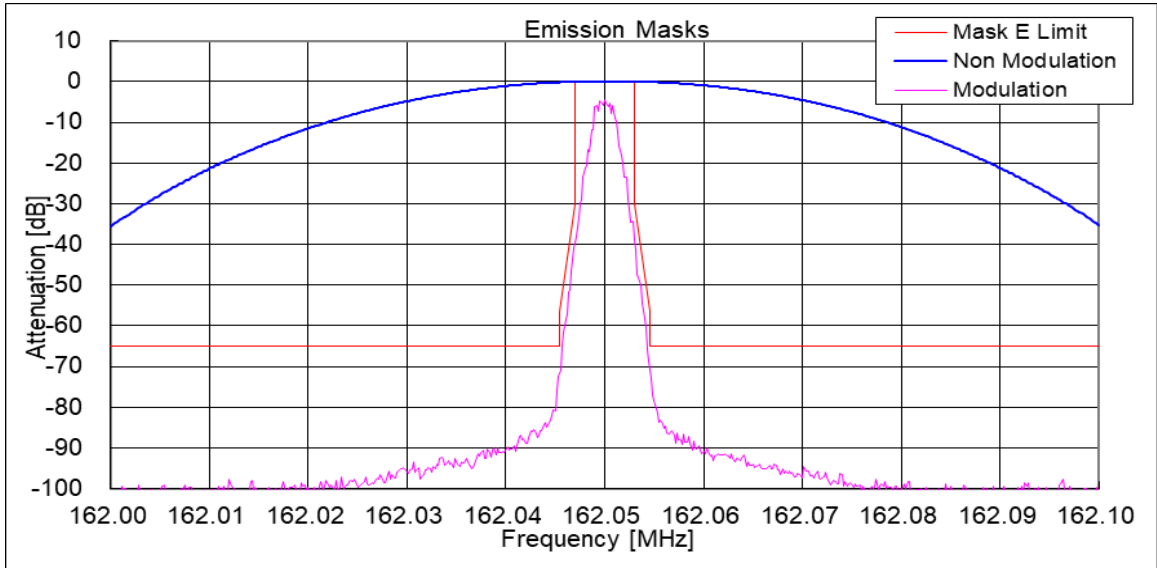

State : Low Power / Authorized Bandwidth 6 kHz/ 4K00F1E / F1D / F7W / 173.95 MHz(FCC/RSS)
Limit : Mask E

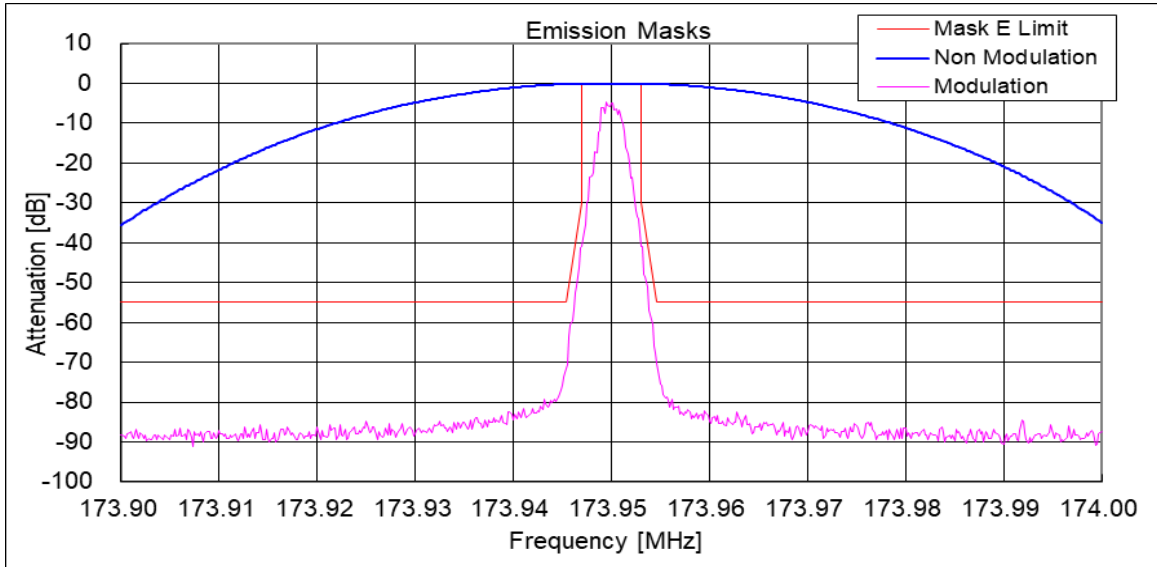

State : High Power / Authorized Bandwidth 6 kHz/ 4K00F2D / 173.95 MHz(FCC/RSS)
Limit : Mask E

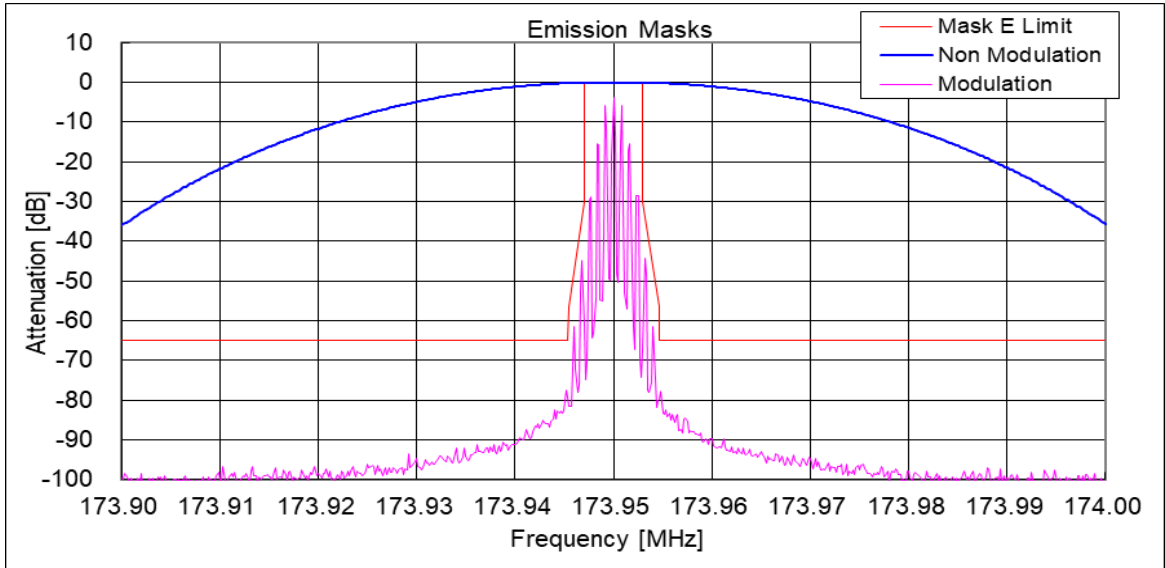

State : Low Power / Authorized Bandwidth 6 kHz/ 4K00F2D / 173.95 MHz(FCC/RSS)
Limit : Mask E

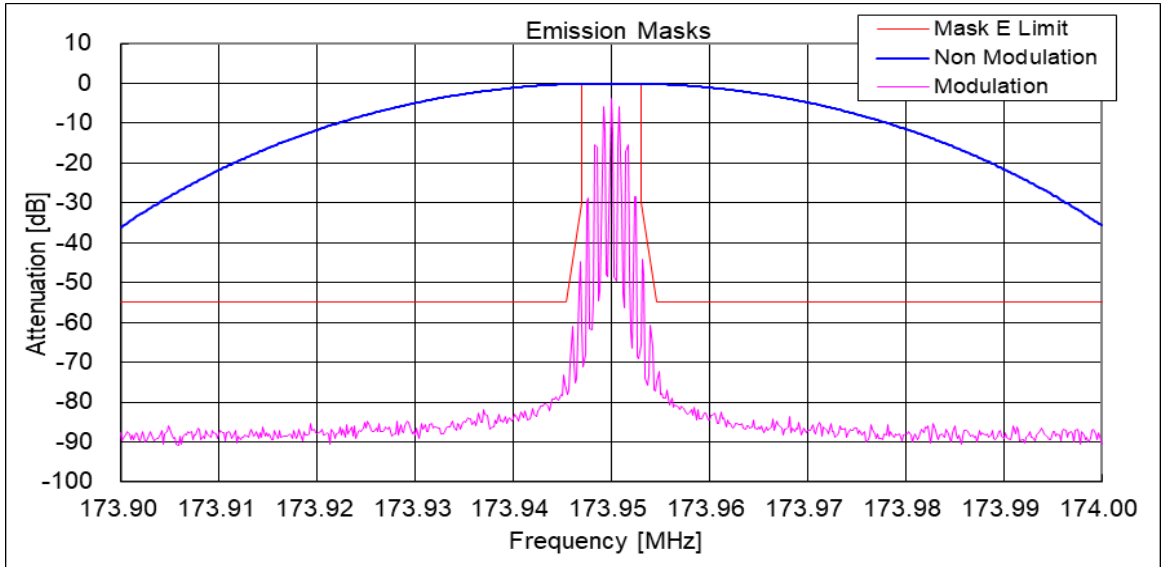

10.5 Transient Frequency Behavior

REGULATIONS : FCC Part 90 Section 214 / RSS-119 Section 5.9

TEST METHOD/GUIDE : ANSI/TIA-603-E, Section 2.2.19.3

Test Procedure

- 1 The EUT and test equipment were set up as shown on the following page.
- 2 The transmitter was turned on.
- 3 The transmitter carrier level was measured at the output of the combiner .
- 4 The transmitter was turned off.
- 5 An RF signal generator (1) modulated with a 1 kHz tone at either 25 kHz or 12.5 kHz or 6.25 kHz deviation, and set to the same frequency as the assigned transmitter frequency, (2) was adjusted to a level -30 dB below the level recorded in Procedure 3, as measured at the output of the combiner.
 This level was then fixed for the remainder of the test and is recorded at step h.
- 6 The oscilloscope was setup using TIA-603 steps j and k as a guide, however 1000 Hz tone was adjusted at +- 2.5 /div vertically centered on the display.
- 7 The transmitter was turned on, and the level of the carrier at the output of the combiner was recorded as step l.
- 8 The carrier on-time as referenced in TIA-603 steps m, n, and o was captured and plotted.
- 9 The carrier off-time as referenced in TIA-603 steps p, q, r, and s was captured and plotted.

No.	Equipment	Manufacture	Model No.	Serial No.	Cal. Interval	Effective period
1	Power Meter	Hewlett Packard	E4418B	GB38410265	1Y	Aug. 31, 22
2	Power Sensor	Hewlett Packard	8482A	US37292237	1Y	Aug. 31, 22
3	Attenuator (20dB)	Aeroflex/Wenshel	66-20-34	BY4357	1Y	Sep. 30, 22
4	Attenuator (3dB)	TME	CFA-20NPJ-3	679701	1Y	Mar. 31, 22
5	Attenuator (30dB)	Weinschel	WA-29-30-34	8923	1Y	Sep. 30, 22
6	Step Attenuator	Hewlett Packard	8494B	272614515	1Y	Sep. 30, 22
7	Combiner(1)	Anritsu	Z-164A	M89249	1Y	Mar. 31, 22
8	Combiner(2)	Anritsu	Z-164A	M89549	1Y	Mar. 31, 22
9	Modulation Analyzer	Hewlett Packard	8901B	3403A04852	1Y	Dec. 31, 22
10	Signal Generator	Rohde&Schwarz	SMB 100A	105709	1Y	May. 31, 22
11	Oscilloscope	Tektronix	TDS5104	B040901	1Y	Aug. 31, 22
12	DC Power Supply	Daiichi denpa kogyo	GZV4000	90290931	None	None
13	Digital Multi Meter	FLUKE	8846A	9642018	1Y	Jun. 30, 22

Measuring Cables

No.	Cable	Manufacture	Model No.	Serial No.	Cal. Interval	Effective period
W2	Coaxial Cable	Pacific custom	RG-58 C/U	KSR00094	1Y	Jan. 31, 23
W4	Coaxial Cable	Pacific custom	RG-58 C/U	KSR00096	1Y	Mar. 31, 22
W5	Coaxial Cable	Pacific custom	RG-58 C/U	AM90C04	1Y	Mar. 31, 22
W3	Coaxial Cable	Pacific custom	RG-58 C/U	KSR00041	1Y	Mar. 31, 22

Measuring Equipment Configuration

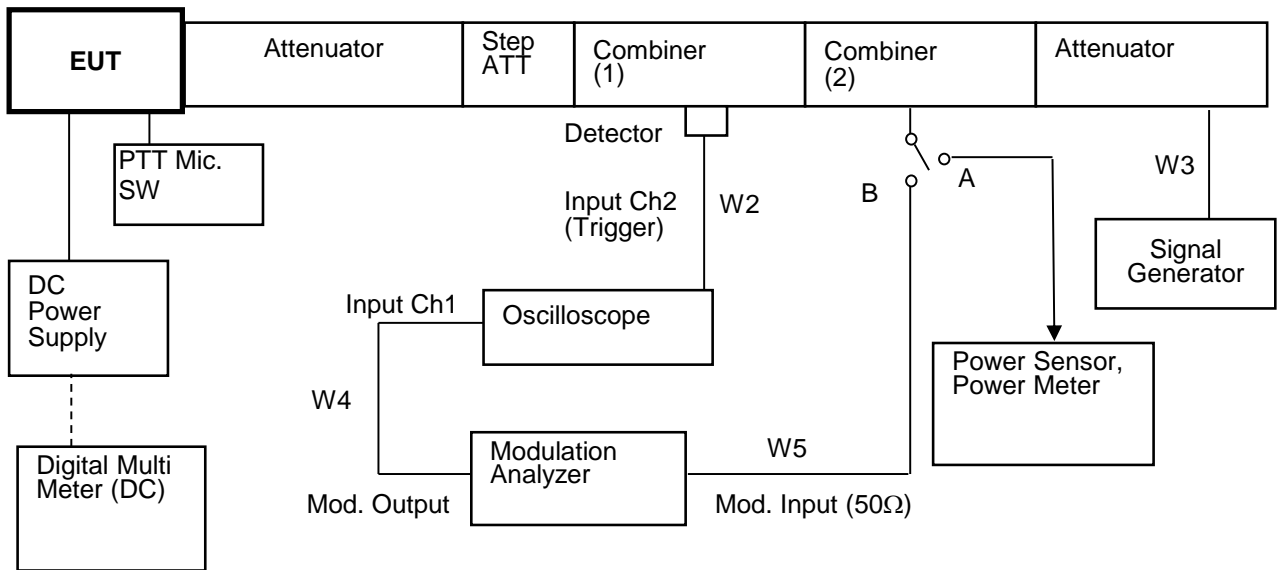

Test Results

Test date	Jan 28, 2022	to	Jan 31, 2022
Location	Kashima No.12 Test Site		
temperature	21	to	23 [degree C]
Humidity Variation	50	to	55 [%]
Atmospheric Pressure	101.1	to	101.3 [kPa]
Test Engineer	Koichi Wagatsuma		

Test was carried out for all the frequency band of section 10.1
 State the worst case (below).

State : High Power / Authorized Bandwidth 20 kHz / 16K0F3E / 173.95 MHz (FCC)/ PTT:OFF -ON

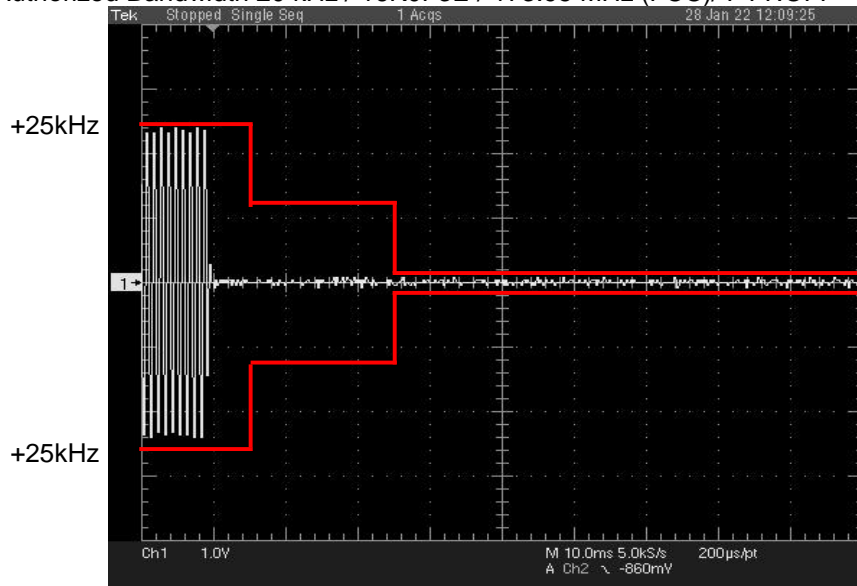

State : High Power / Authorized Bandwidth 20 kHz / 16K0F3E / 173.95 MHz (FCC)/ PTT:ON -OFF

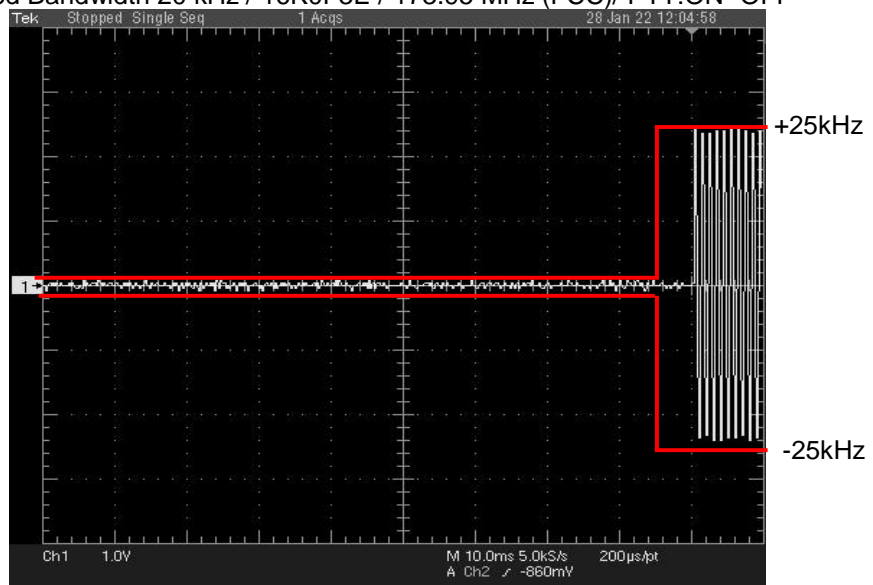

State : High Power / Authorized Bandwidth 11.25 kHz / 11K0F3E / 162.05 MHz (FCC/RSS)/ PTT:OFF -ON

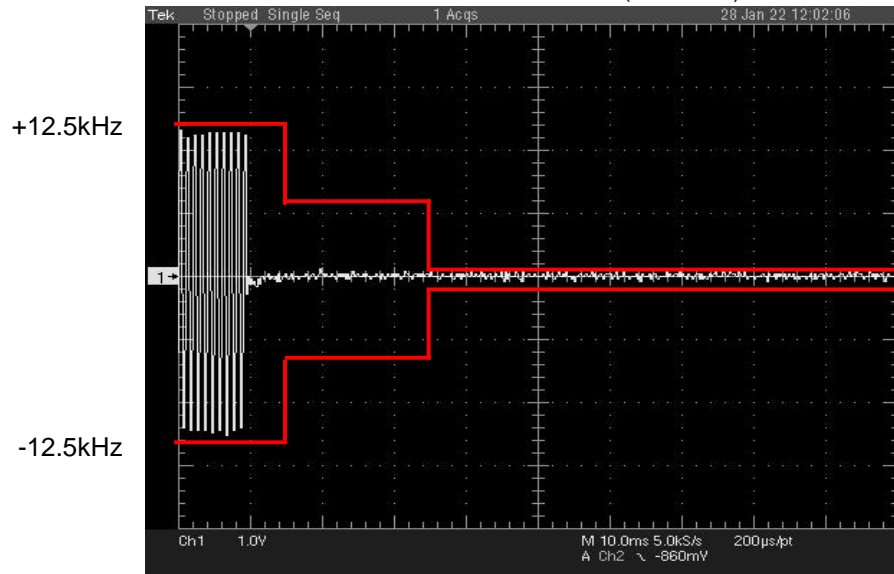

State : High Power / Authorized Bandwidth 11.25 kHz / 11K0F3E / 162.05 MHz (FCC/RSS)/ PTT:ON-OFF

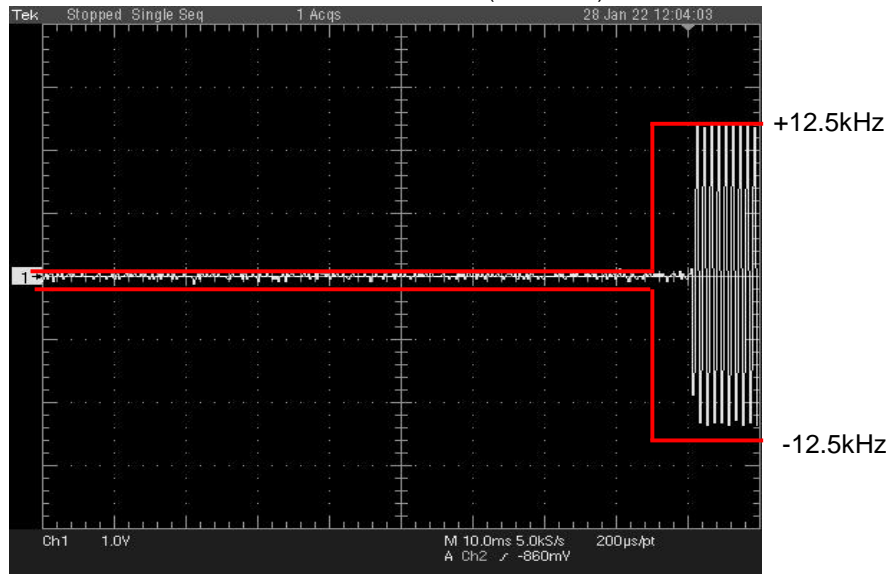

State : High Power / Authorized Bandwidth 11.25 kHz / 7K60FXD/FXE/F7E/F7D/F7W/FXW / 173.95 MHz (FCC/RSS)/ PTT:OFF -ON

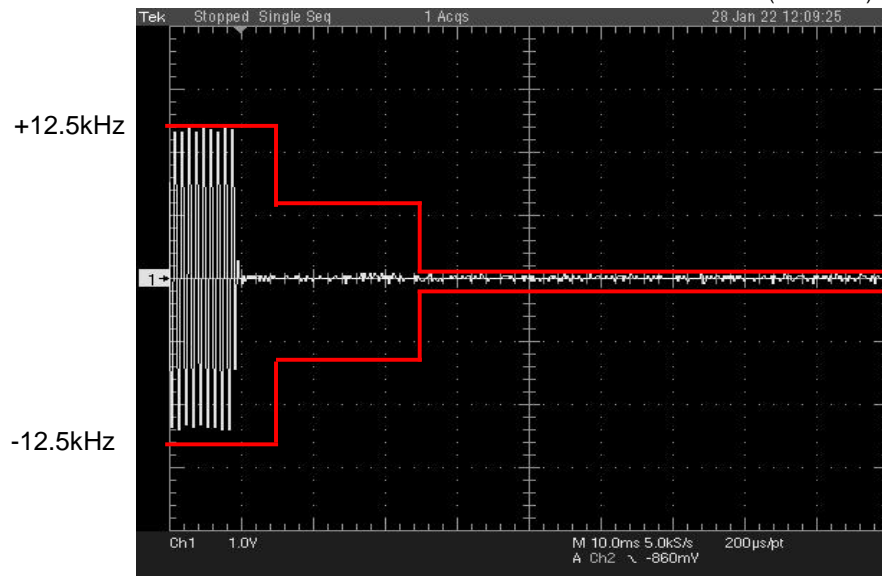

State : High Power / Authorized Bandwidth 11.25 kHz / 7K60FXD/FXE/F7E/F7D/F7W/FXW / 173.95 MHz (FCC/RSS)/ PTT:ON -OFF

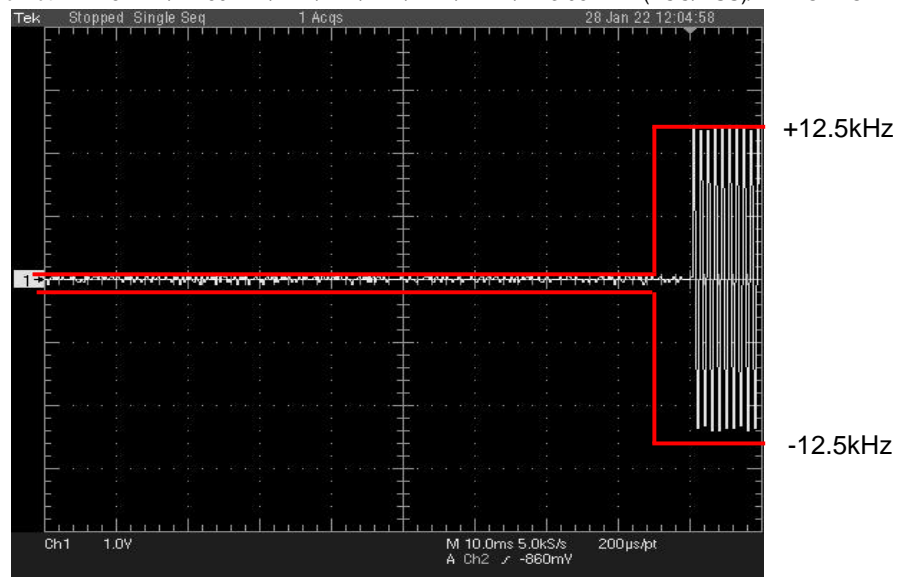

State : High Power / Authorized Bandwidth 11.25 kHz / 8K30F1E/F1D/F7W / 162.05 MHz (FCC/RSS)/ PTT:OFF -ON

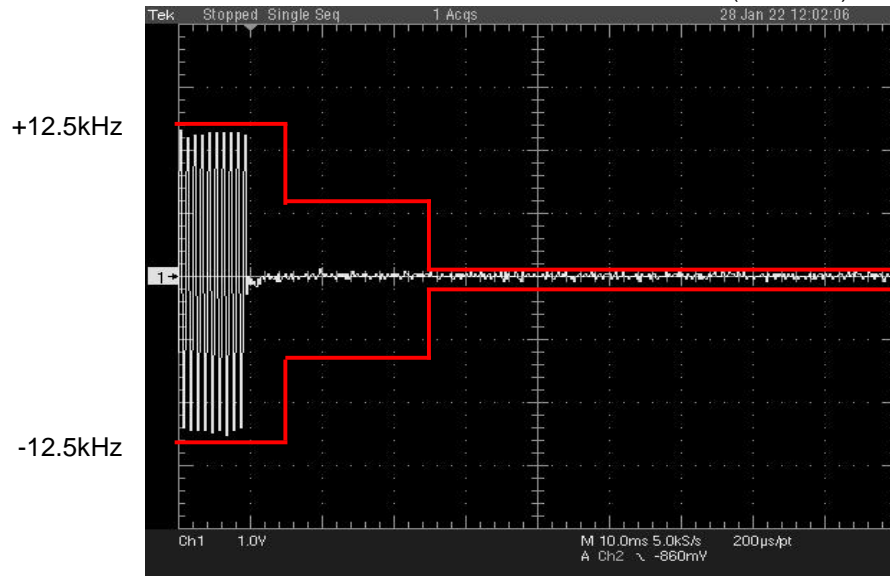

State : High Power / Authorized Bandwidth 11.25 kHz / 8K30F1E/F1D/F7W / 162.05 MHz (FCC/RSS)/ PTT:ON-OFF

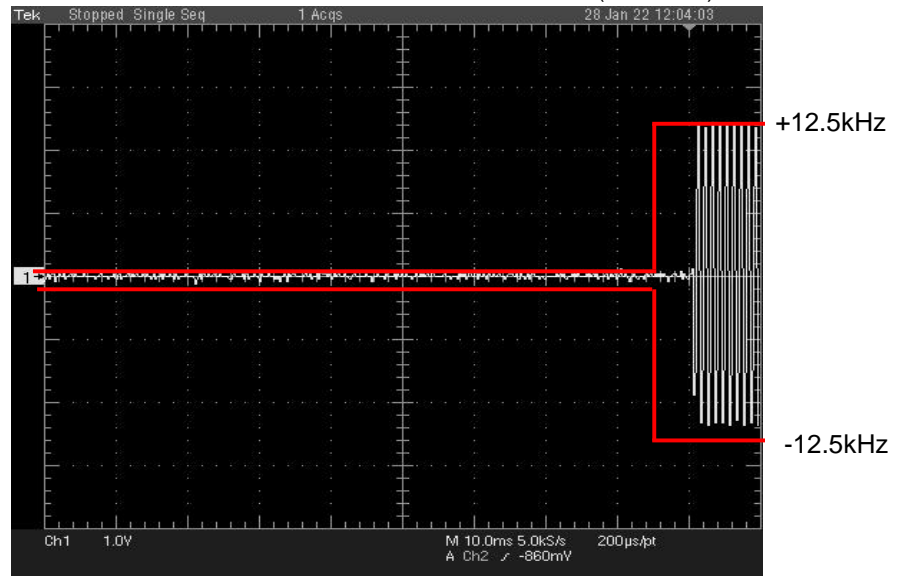

State : High Power / Authorized Bandwidth 6 kHz / 4K00F1E / F1D / F7W / 162.05 MHz (FCC/RSS)/ PTT:OFF -ON

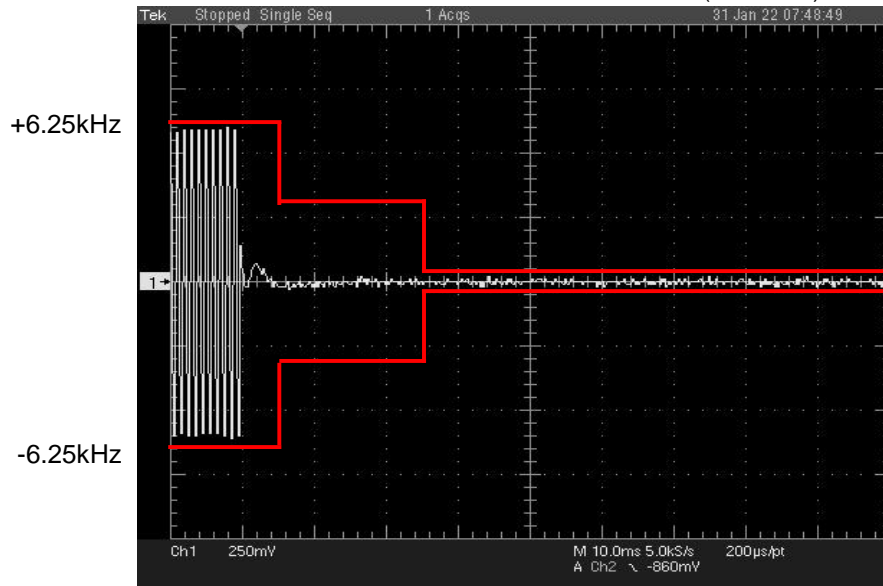

State : High Power / Authorized Bandwidth 6 kHz / 4K00F1E / F1D / F7W / 162.05 MHz (FCC/RSS)/ PTT:ON-OFF

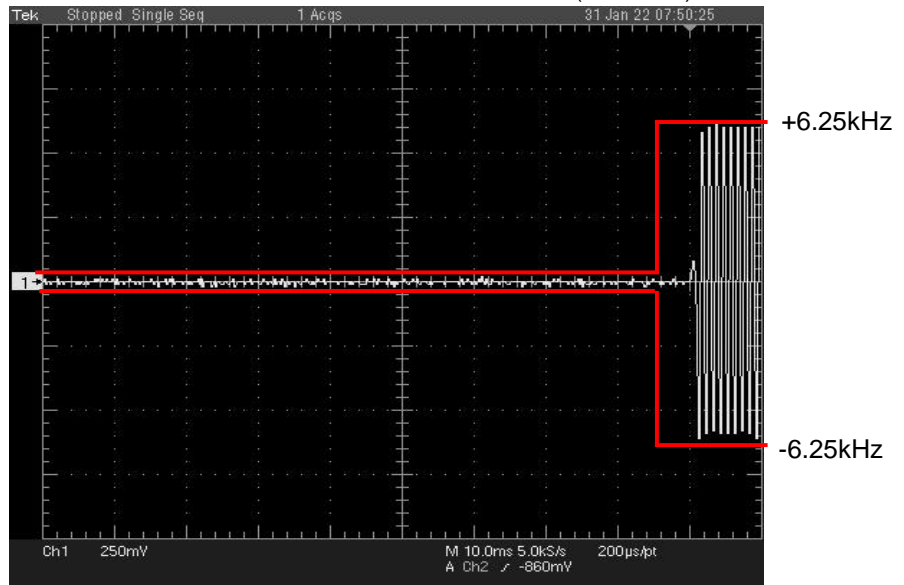

State : High Power / Authorized Bandwidth 6 kHz / 4K00F2D / 162.05 MHz (FCC/RSS)/ PTT:OFF -ON

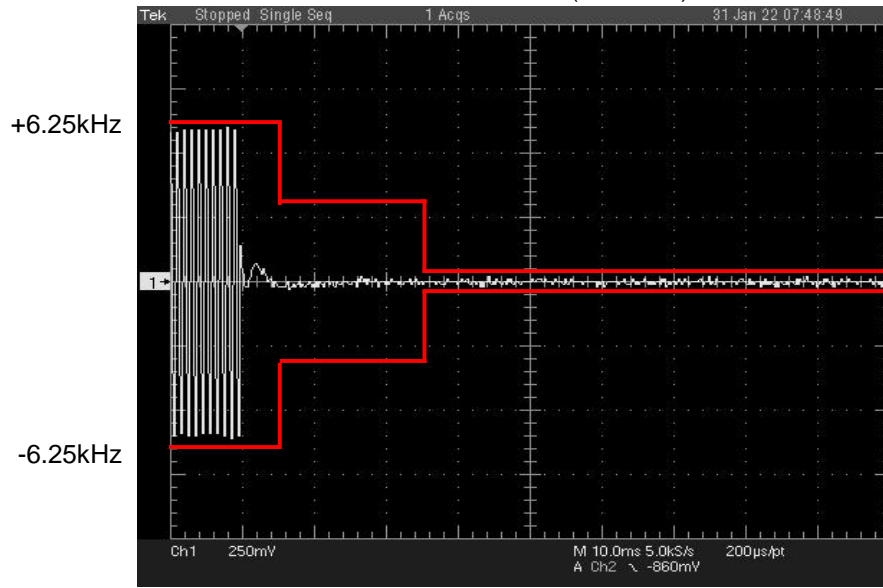

State : High Power / Authorized Bandwidth 6 kHz / 4K00F2D / 162.05 MHz (FCC/RSS)/ PTT:ON-OFF

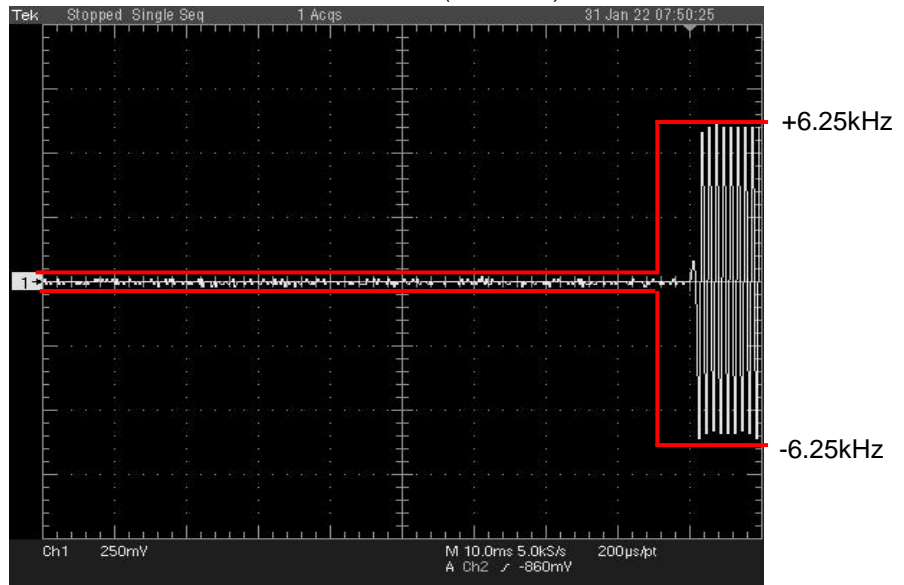

10.6 Audio Frequency Response / Audio Low Pass Filter (Voice Input)

REGULATIONS	: FCC Part 2 Section 1047 (a) FCC Part 80 Section 213
TEST METHOD/GUIDE	: ANSI/TIA-603-E Section 2.2.6.2.2, 3.2.6.2 ANSI C63.26 Section 5.3.3

Test Procedure

- 1 The EUT and test equipment were set up as shown on the following page.
- 2 Adjust the Modulation Analyzer for the following setting:
 - a) High-pass filter : 50 Hz
 - b) Low-pass filter : 15 kHz
 - c) Detector : positive peak
 - d) Function : FM
- 3 The audio signal input was adjusted to obtain 20 % modulation at 1 kHz, and this point was taken as the 0 dB reference level.
- 4 With input levels held constant and below limiting at all frequencies, the audio signal generator was varied from 100 Hz to 5 kHz.
- 5 The response in dB relative to 1 kHz was then measured, using the Modulation Analyzer.

Measuring Equipments

No.	Equipment	Manufacture	Model No.	Serial No.	Cal. Interval	Effective period
1	Attenuator (20dB)	Aeroflex/Wenshel	66-20-34	BY4357	1Y	Sep. 30, 22
2	Attenuator (30dB)	Weinschel	WA-29-30-34	8923	1Y	Sep. 30, 22
3	Modulation Analyzer	Hewlett Packard	8901B	3403A04852	1Y	Dec. 31, 22
4	Audio Generator	Anritsu	MG443B	M70150	1Y	Jun. 30, 22
5	Audio Analyzer	Hewlett Packard	8903B	2948A07326	1Y	Oct. 31, 22
6	DC Power Supply	Daiichi denpa kogyo	GZV4000	90290931	None	None
7	Digital Multi Meter	FLUKE	8846A	9642018	1Y	Jun. 30, 22

Measuring Cables

No.	Cable	Manufacture	Model No.	Serial No.	Cal. Interval	Effective period
W2	Balance Cable	Nicoon	3D-2V	KSR00092	1Y	Sep. 30, 22
W4	Coaxial Cable	Pacific custom	RG-58 C/U	KSR00096	1Y	Mar. 31, 22
W3	Coaxial Cable	Pacific custom	RG-58 C/U	AM90C04	1Y	Mar. 31, 22

Measuring Equipment Configuration

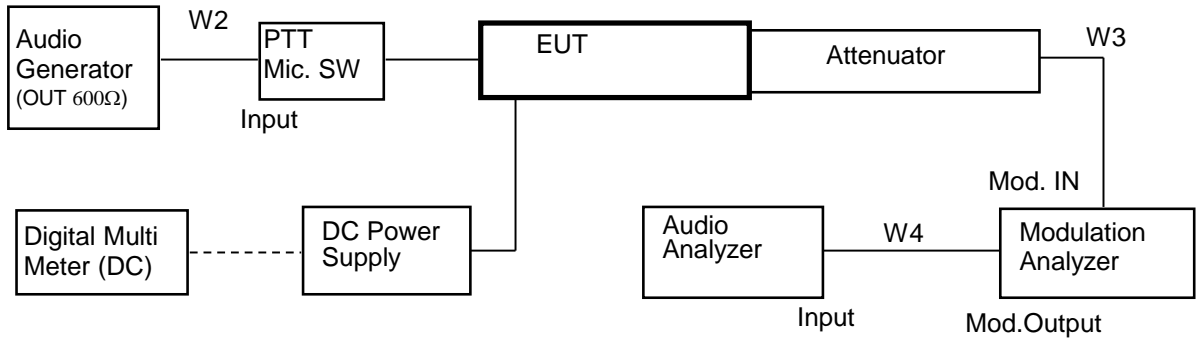

Test Results

Test date	Jan 28, 2022	
Location	Kashima No.12 Test Site	
temperature	24.8	[degree C]
Humidity Variation	68	[%]
Atmospheric Pressure	101.7	[kPa]
Test Engineer	Koichi Wagatsuma	

Test was carried out for all the frequency band of section 10.1
 State the worst case (below).

State : High Power / Authorized Bandwidth 20 kHz / 16K0F3E / 138.05 MHz(RSS)

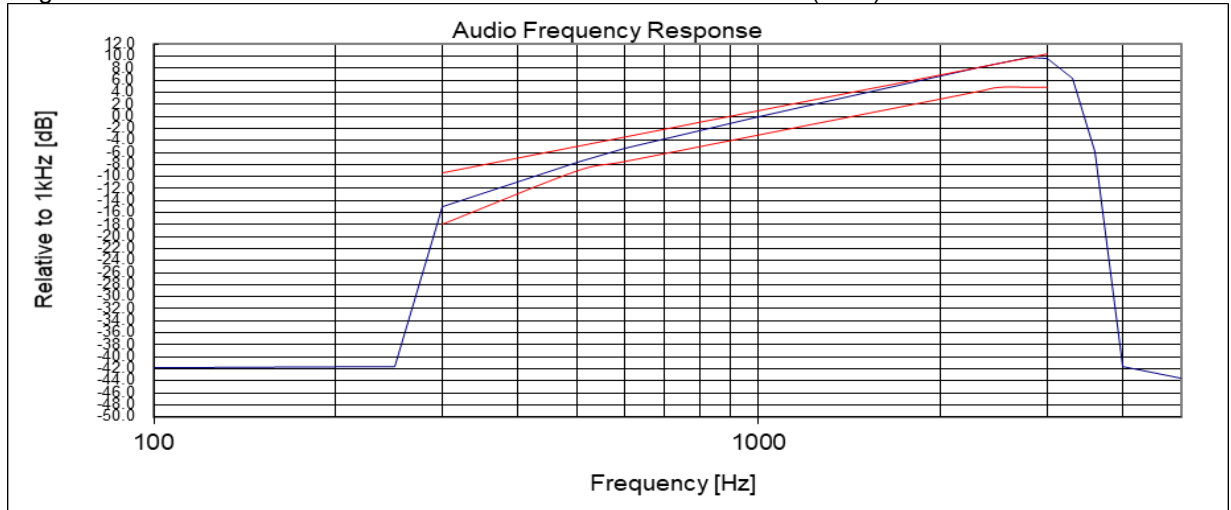

Note:

Audio Filter of the above result is substituted with the same structure as Audio Frequency Response.
 On the transmission condition below 3kHz,
 Transceiver shows pre-emphasis condition of transmission function.
 On the transmission condition above 3kHz, Transceiver shows Audio Low Pass Filter.

State : High Power / Authorized Bandwidth 20 kHz / 16K0F3E / 150.05 MHz(FCC)

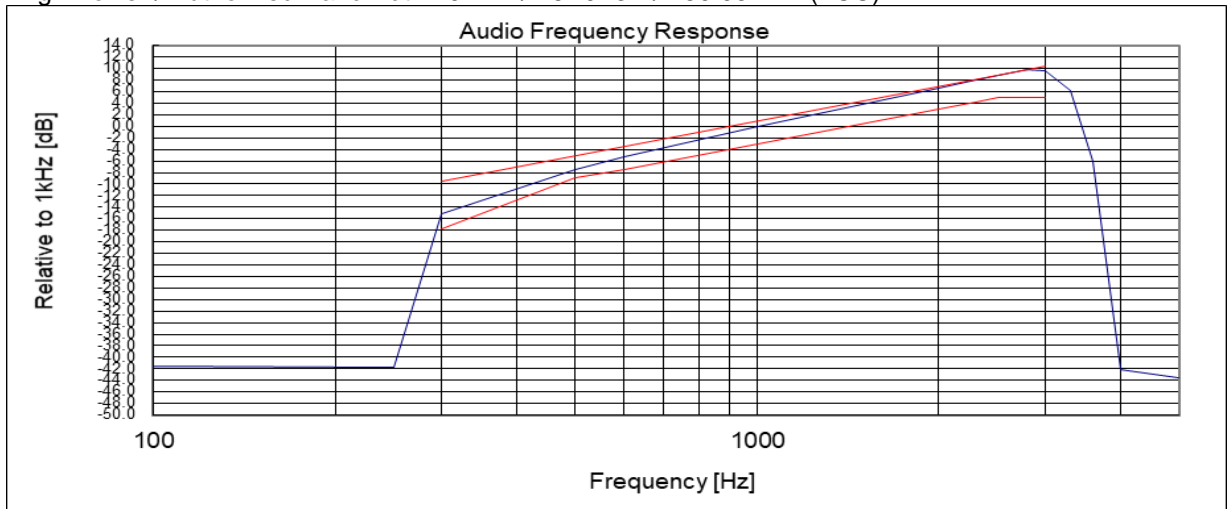

Note:

Audio Filter of the above result is substituted with the same structure as Audio Frequency Response.

On the transmission condition below 3kHz,

Transceiver shows pre-emphasis condition of transmission function.

On the transmission condition above 3kHz, Transceiver shows Audio Low Pass Filter.

State : High Power / Authorized Bandwidth 11.25 kHz / 11K0F3E / 138.05 MHz(RSS)

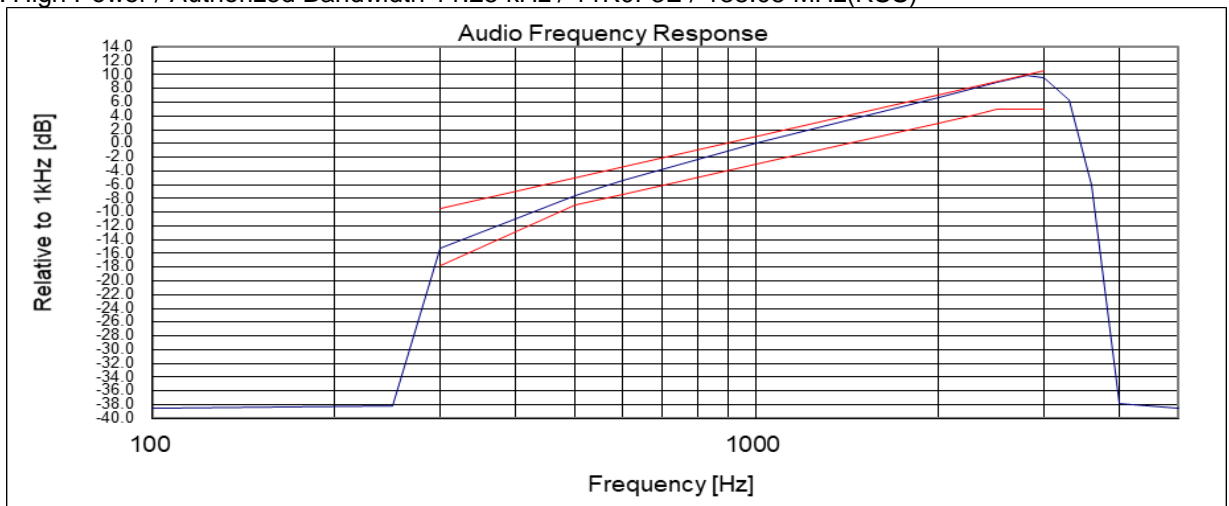

Note:

Audio Filter of the above result is substituted with the same structure as Audio Frequency Response.

On the transmission condition below 3kHz,

Transceiver shows pre-emphasis condition of transmission function.

On the transmission condition above 3kHz, Transceiver shows Audio Low Pass Filter.

State : High Power / Authorized Bandwidth 11.25 kHz / 11K0F3E / 150.05 MHz(FCC)

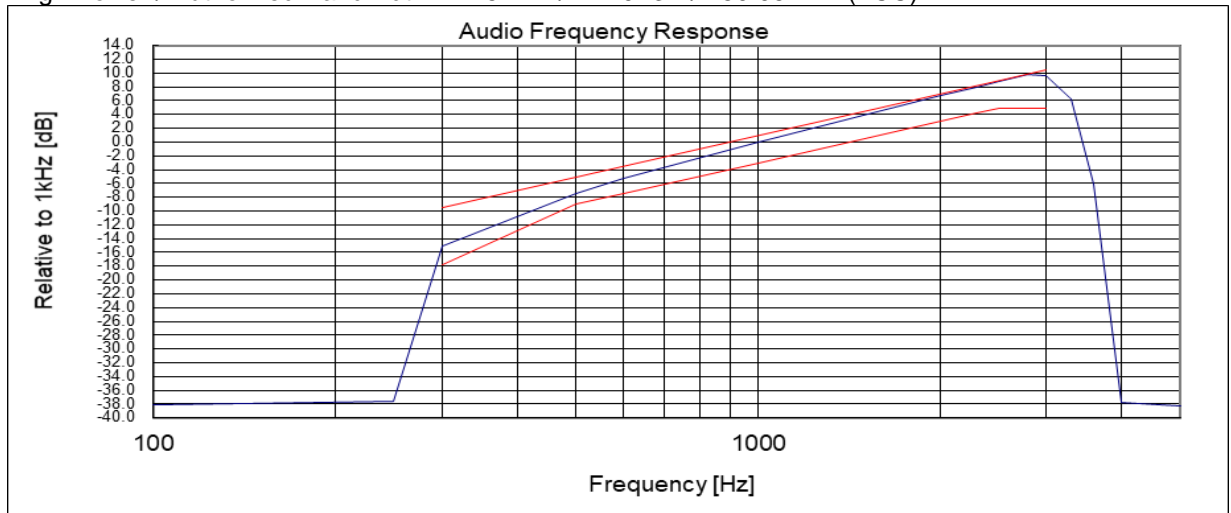

Note:

Audio Filter of the above result is substituted with the same structure as Audio Frequency Response.

On the transmission condition below 3kHz,

Transceiver shows pre-emphasis condition of transmission function.

On the transmission condition above 3kHz, Transceiver shows Audio Low Pass Filter.

10.7 Modulation Limiting

REGULATIONS	: FCC Part 2 Section 1047 (b) FCC Part 80 Section 213
TEST METHOD/GUIDE	: ANSI/TIA-603-E Section 2.2.3.2, 1.3.4.4 ANSI C63.26 Section 5.3.2

Test Procedure

- 1 The EUT and test equipment were set up as shown on the following page.
- 2 Adjust the Modulation Analyzer for the following setting:
 - a) High-pass filter : off
 - b) Low-pass filter : 15 kHz
 - c) Detector : positive peak
 - d) Function : FM
- 3 Apply a 1kHz modulation signal to the transmitter from the audio generator, and adjust the level to obtain 60% of full rated system deviation.
- 4 Measure the modulation frequency that was showed on the Modulation Analyzer when the output levels of the Audio Generator were changed from -20 dB to +20 dB by 5 dB.
- 5 Set the output frequencies of the Audio Generator 300 Hz, 1kHz, 2.5 kHz and 3 kHz, and repeat test procedure 4.
- 6 Set the Detector of the Modulation Analyzer Negative Peak.
- 7 Repeat test procedure 4 and 5.

Measuring Equipments

No.	Equipment	Manufacture	Model No.	Serial No.	Cal. Interval	Effective period
1	Attenuator (20dB)	Aeroflex/Wenshel	66-20-34	BY4357	1Y	Sep. 30, 22
2	Attenuator (30dB)	Weinschel	WA-29-30-34	8923	1Y	Sep. 30, 22
3	Modulation Analyzer	Hewlett Packard	8901B	3403A04852	1Y	Dec. 31, 22
4	Audio Generator	Anritsu	MG443B	M70150	1Y	Jun. 30, 22
5	DC Power Supply	Daiichi denpa kogyo	GZV4000	90290931	None	None
4	Digital Multi Meter	FLUKE	8846A	9642018	1Y	Jun. 30, 22

Measuring Cables

No.	Cable	Manufacture	Model No.	Serial No.	Cal. Interval	Effective period
W2	Balance Cable	Nicoon	3D-2V	KSR00092	1Y	Sep. 30, 22
W3	Coaxial Cable	Pacific custom	RG-58 C/U	AM90C04	1Y	Mar. 31, 22

Measuring Equipment Configuration

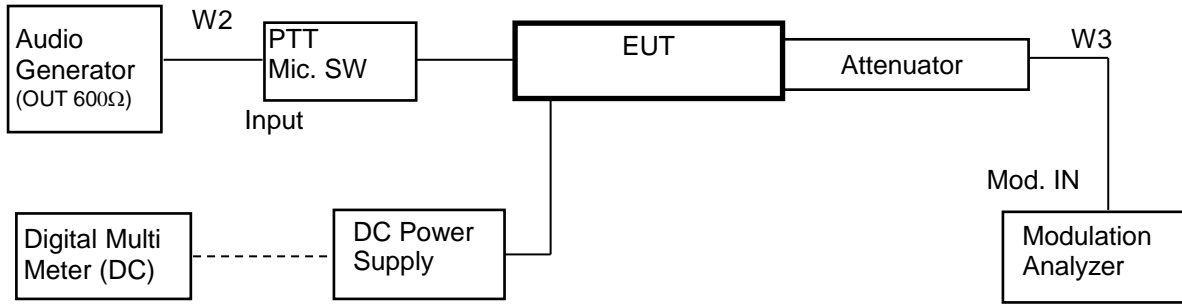

Test Results

Test date	Jan. 28, 2022	
Location	Kashima No.12 Test Site	
temperature	24.7	[degree C]
Humidity Variation	45	[%]
Atmospheric Pressure	100.9	[kPa]
Test Engineer	Koichi Wagatsuma	

Test was carried out for all the frequency band of section 10.1
 State the worst case (below).

State : High Power / Authorized Bandwidth 20 kHz / 16K0F3E / 138.05 MHz(RSS)

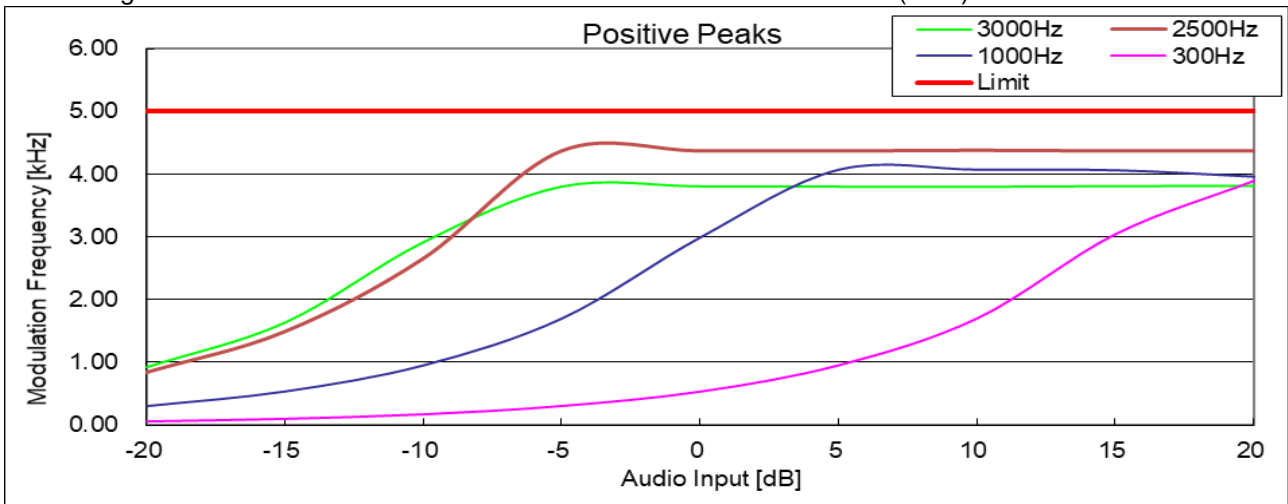

State : High Power / Authorized Bandwidth 20 kHz / 16K0F3E / 138.05 MHz(RSS)

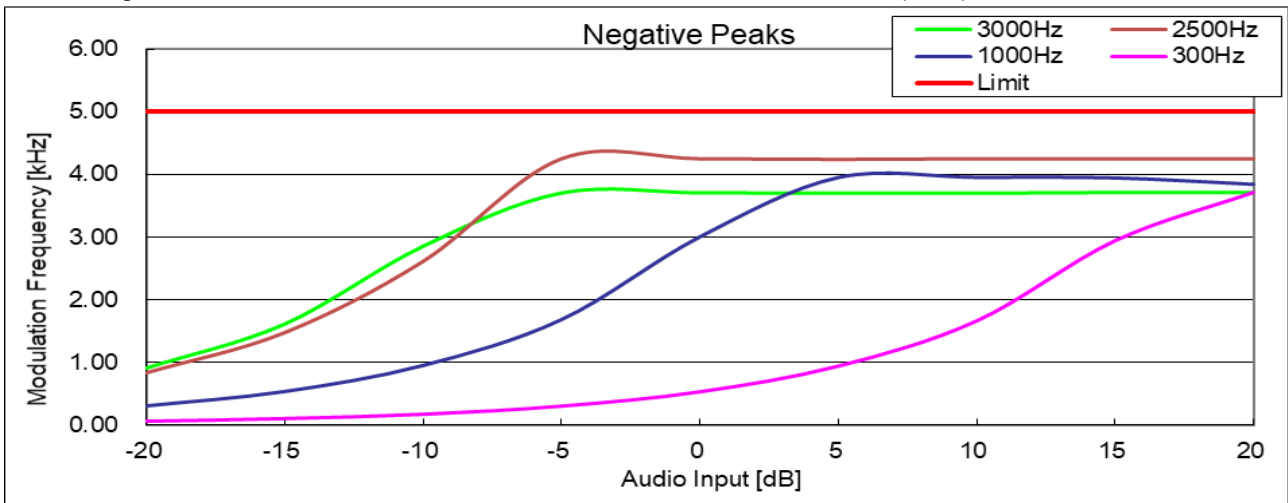

State : High Power / Authorized Bandwidth 20 kHz / 16K0F3E / 150.05 MHz(FCC)

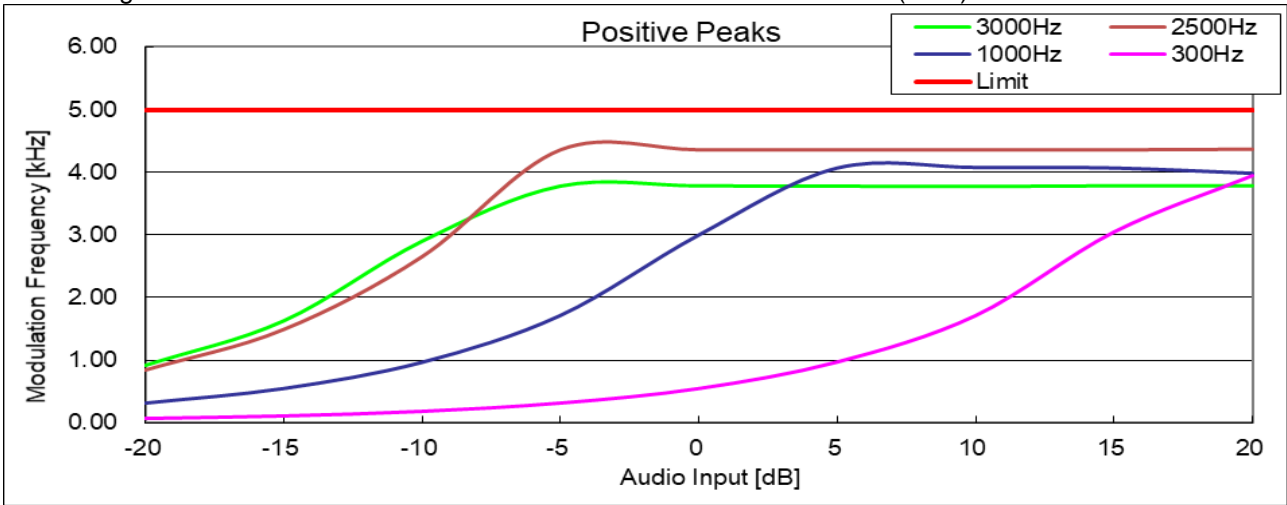

State : High Power / Authorized Bandwidth 20 kHz / 16K0F3E / 150.05 MHz(FCC)

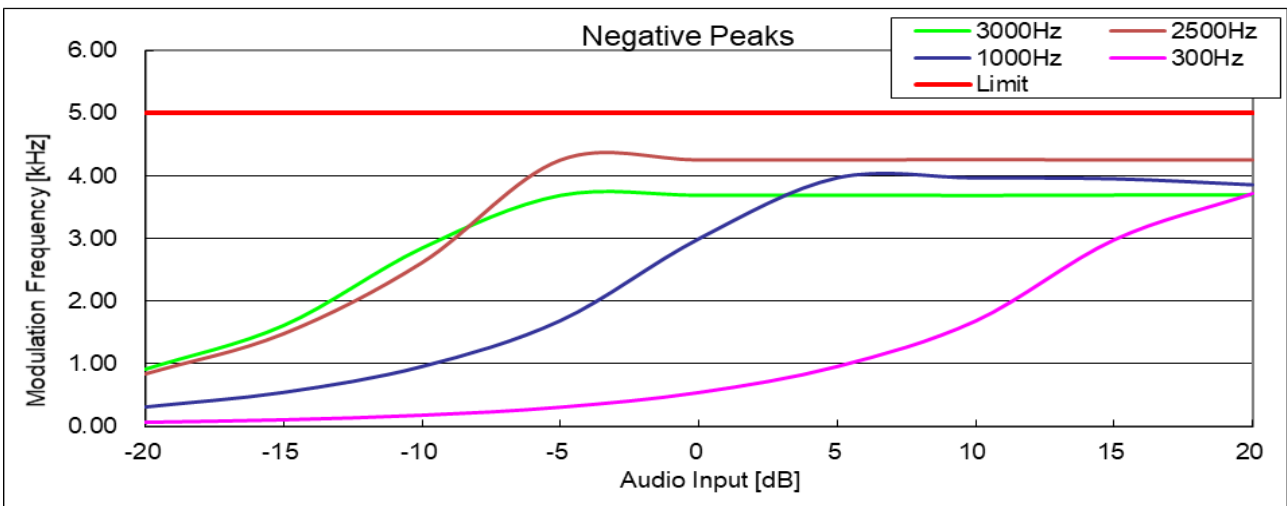

State : High Power / Authorized Bandwidth 11.25 kHz / 11K0F3E / 162.05 MHz(FCC / RSS)

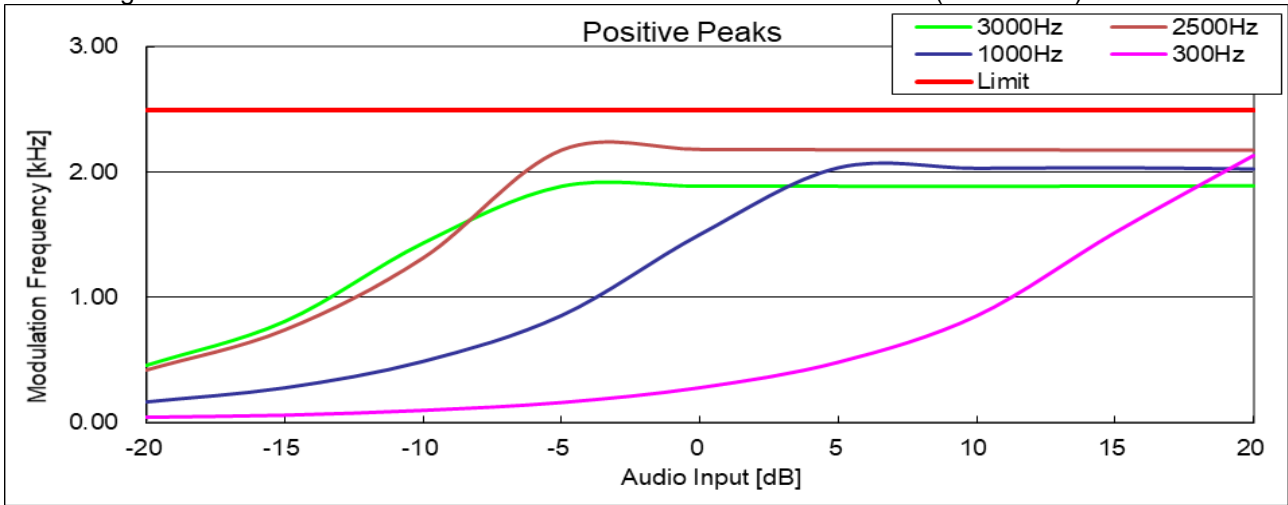

State : High Power / Authorized Bandwidth 11.25 kHz / 11K0F3E / 162.05 MHz(FCC / RSS)

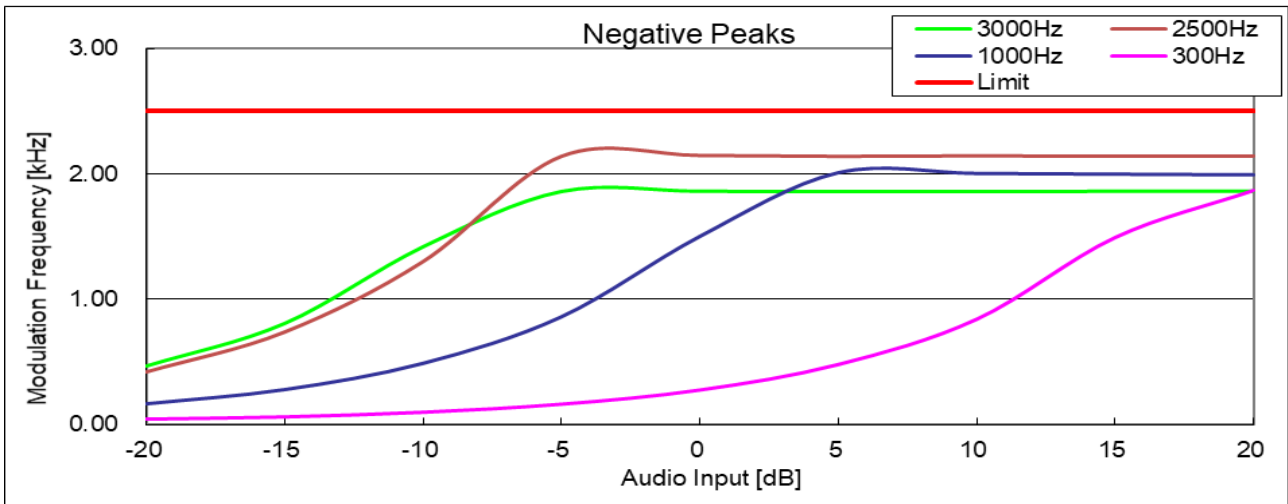

10.8 Frequency Stability (Temperature Variation)

REGULATIONS	: FCC Part 2 Section 1055 (a) (1), Part 22 Section 355 , Part 74Section 464 , Part 90 Section 213(a)
TEST METHOD/GUIDE	: ANSI/TIA-603-E Section 2.2.2.2 ANSI C63.26 Section 5.6

Test Procedure

- 1 The EUT and test equipment were set up as shown on the following page.
- 2 Set the temperature -30 degrees C.
- 3 Leave the EUT for 1 hour after it became the temperature that was set up.
- 4 Make the EUT the transmitting state.
measure the output frequency.
- 5 Make the EUT the receiving state.
- 6 Set the temperature 50 degrees C by 10 degrees C.
And repeat test procedure 4 to 6.

Measuring Equipments

No.	Equipment	Manufacture	Model No.	Serial No.	Cal. Interval	Effective period
1	Attenuator (20dB)	Aeroflex/Wenshel	66-20-34	BY4357	1Y	Sep. 30, 22
2	Attenuator (30dB)	Weinschel	WA-29-30-34	8923	1Y	Sep. 30, 22
3	Modulation Analyzer	Hewlett Packard	8901B	3403A04852	1Y	Dec. 31, 22
4	DC Power Supply	Takasago	GP035-20R	1014199060	None	None
5	Digital Multi Meter	FLUKE	8846A	9642018	1Y	Jun. 30, 22
6	Temperature Chamber	Tabai	PL-3F	5103661	None	None
7	Temperature Meter	T&D	TR-71nw	52160B67	1Y	Mar. 31, 22
8	GPS Receiver	Hewlett Packard	HP Z3801A	3542A02414	1Y	Feb. 28, 22

Measuring Cables

No.	Cable	Manufacture	Model No.	Serial No.	Cal. Interval	Effective period
W1	Coaxial Cable	Pacific custom	RG-58 C/U	AM90C04	1Y	Mar. 31, 22
W2	Coaxial Cable	Pacific custom	RG-58 C/U	KSR00041	1Y	Mar. 31, 22

Measuring Equipment Configuration

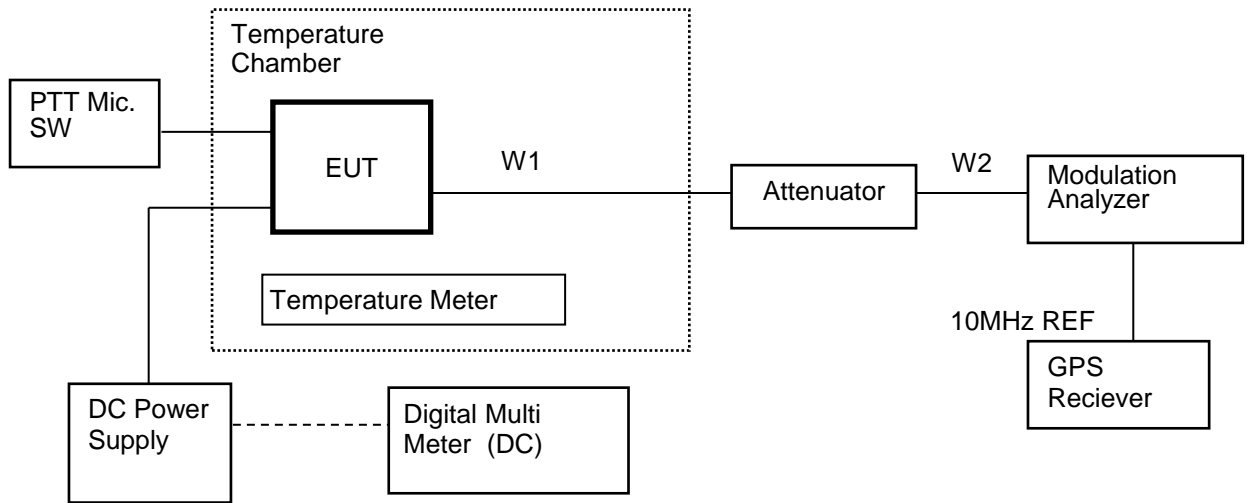

Test Results

Test date	Jan. 31, 2022
Location	Kashima No.12 Test Site
Test Engineer	Koichi Wagatsuma

Test was carried out for all the frequency band of section 10.1
 State the worst case (below).

State : High Power / Authorized Bandwidth 20 kHz / 138.05 MHz (RSS)

Reference Frequency: 138.050040 MHz

No.	Temperature (Degree C)	Frequency (MHz)	Stability (ppm)	Limit (+/- ppm)	Min. Margin (ppm)
1	-30	138.050060	0.14	0.5	0.36
2	-20	138.050050	0.07	0.5	0.43
3	-10	138.050030	-0.07	0.5	0.43
4	0	138.050030	-0.07	0.5	0.43
5	10	138.050040	0.00	0.5	0.50
6	20	138.050040	0.00	0.5	0.50
7	30	138.050040	0.00	0.5	0.50
8	40	138.050030	-0.07	0.5	0.43
9	50	138.050010	-0.22	0.5	0.28

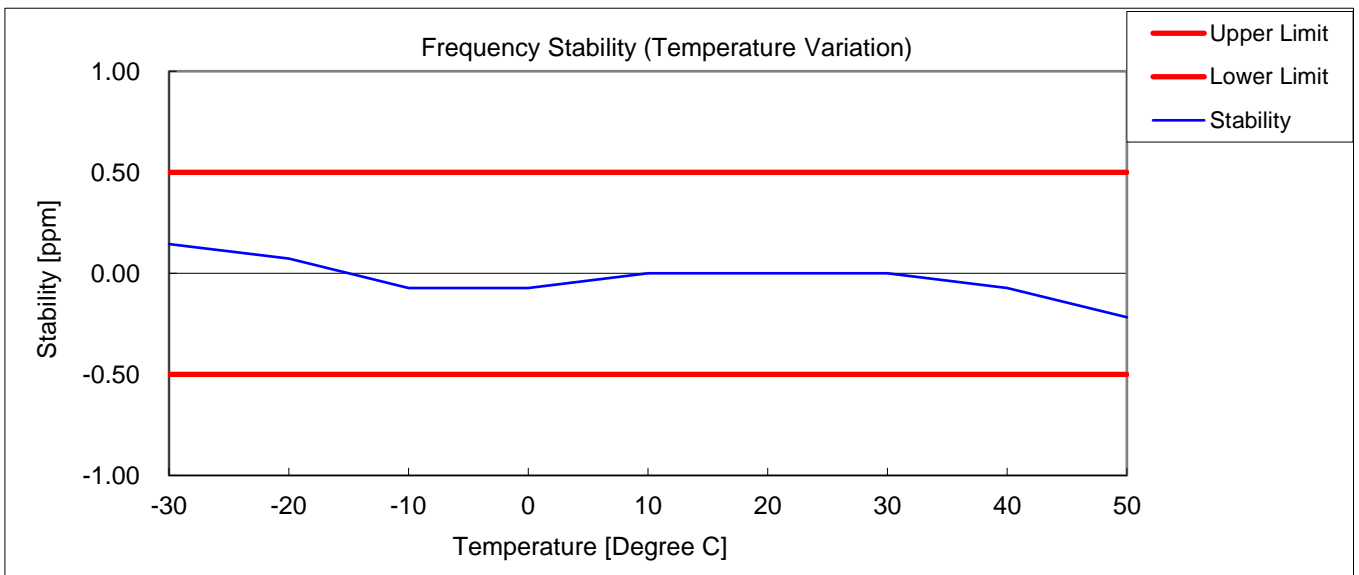

State : High Power / Authorized Bandwidth 20 kHz / 150.05 MHz (FCC)
 Reference Frequency: 150.050040 MHz

No.	Temperature (Degree C)	Frequency (MHz)	Stability (ppm)	Limit (+/- ppm)	Min. Margin (ppm)
1	-30	150.050060	0.13	0.5	0.37
2	-20	150.050050	0.07	0.5	0.43
3	-10	150.050030	-0.07	0.5	0.43
4	0	150.050030	-0.07	0.5	0.43
5	10	150.050050	0.07	0.5	0.43
6	20	150.050040	0.00	0.5	0.50
7	30	150.050040	0.00	0.5	0.50
8	40	150.050030	-0.07	0.5	0.43
9	50	150.050010	-0.20	0.5	0.30

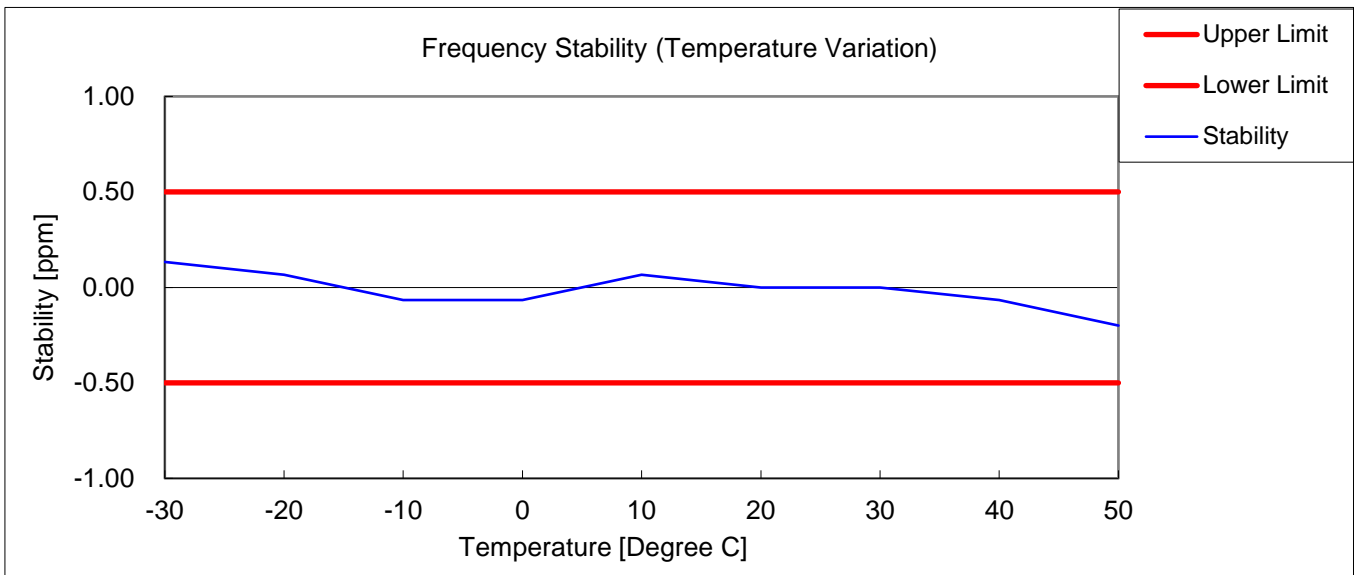

10.9 Frequency Stability (Voltage Variation)

REGULATIONS	: FCC Part 2 Section 1055 (a) (1), Part 22 Section 355 , Part 74Section 464 , Part 90 Section 213(a)
TEST METHOD/GUIDE	: ANSI/TIA-603-E Section 2.2.2.2 ANSI C63.26 Section 5.6

Test Procedure

- 1 The EUT and test equipment were set up as shown on the following page.
- 2 The power supply voltage to the EUT was varied from 85 % to 115 % of the nominal value measured at the input to the EUT.

Measuring Equipments

No.	Equipment	Manufacture	Model No.	Serial No.	Cal. Interval	Effective period
1	Attenuator (20dB)	Aeroflex/Wenshel	66-20-34	BY4357	1Y	Sep. 30, 22
2	Attenuator (30dB)	Weinschel	WA-29-30-34	8923	1Y	Sep. 30, 22
3	Modulation Analyzer	Hewlett Packard	8901B	3403A04852	1Y	Dec. 31, 22
4	DC Power Supply	Takasago	GP035-20R	1014199060	None	None
5	Digital Multi Meter	FLUKE	8846A	9642018	1Y	Jun. 30, 22
6	Temperature Chamber	Tabai	PL-3F	5103661	None	None
7	Temperature Meter	T&D	TR-71nw	52160B67	1Y	Mar. 31, 22

Measuring Cables

No.	Cable	Manufacture	Model No.	Serial No.	Cal. Interval	Effective period
W1	Coaxial Cable	Pacific custom	RG-58 C/U	AM90C04	1Y	Mar. 31, 22
W2	Coaxial Cable	Pacific custom	RG-58 C/U	KSR00041	1Y	Mar. 31, 22

Measuring Equipment Configuration

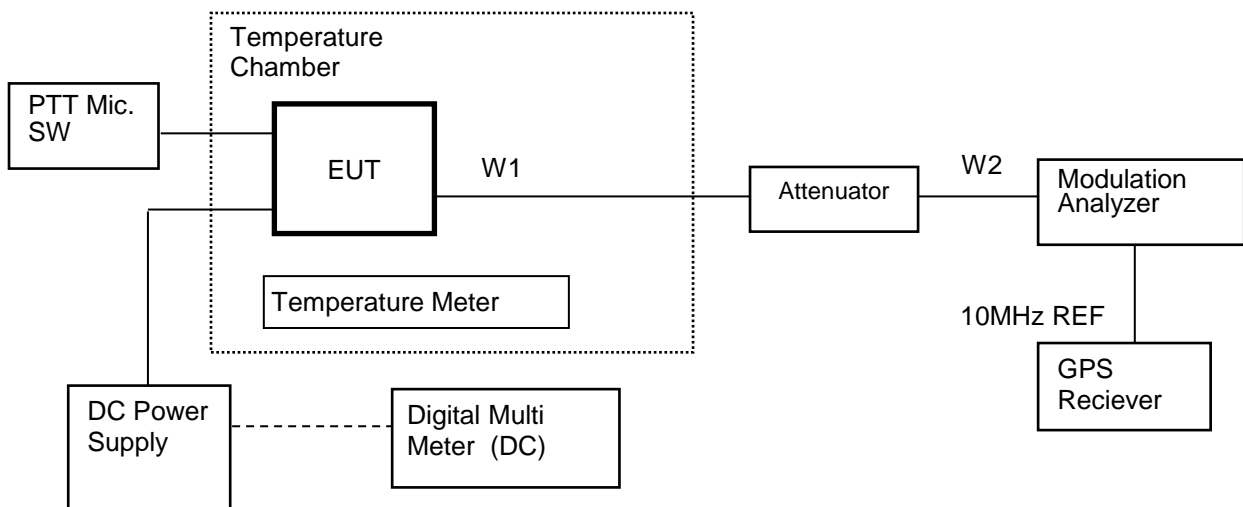

Test Results

Test date	Jan 31, 2022
Location	Kashima No.12 Test Site
Test Engineer	Koichi Wagatsuma

Test was carried out for all the frequency band of section 10.1

State the worst case (below).

State : High Power / Authorized Bandwidth 20 kHz / 138.05 MHz (RSS)

Reference Frequency: 138.050040 MHz

No.	Temperature (Degree C)	Diviation (%)	Voltage (V)	Frequency (MHz)	Stability (ppm)	Limit +/- (ppm)	Margin (ppm)
1	20+/-5	85	11.22	138.050030	-0.07	0.5	0.43
2	20+/-5	100	13.20	138.050040	0.00	0.5	0.50
3	20+/-5	115	15.18	138.050040	0.00	0.5	0.50

State : High Power / Authorized Bandwidth 20 kHz / 150.05 MHz (FCC)

Reference Frequency: 150.050040 MHz

No.	Temperature (Degree C)	Diviation (%)	Voltage (V)	Frequency (MHz)	Stability (ppm)	Limit +/- (ppm)	Margin (ppm)
1	20+/-5	85	11.22	150.050030	-0.07	0.5	0.43
2	20+/-5	100	13.20	150.050040	0.00	0.5	0.50
3	20+/-5	115	15.18	150.050040	0.00	0.5	0.50

10.10 Receiver Spurious Emissions(Radiated)

REGULATIONS	:	RSS-Gen Section 7
TEST METHOD/GUIDE	:	RSS-Gen Section 7

TEST PROCEDURE

- 1 The EUT and test equipment were set up as shown on the following page.
- 2 Tabletop Equipment
EUT is placed on the wooden table, the top of which is 0.8meter above the metal ground plane(turntable).
- 3 Interconnecting Cables
Excess part of the interconnecting cables longer than 1 meter are bundled in the center. Cables that hang closer than 40 cm to the ground plane is folded back and forth forming bundle 30 to 40 cm long, hanging approx, in the middle between ground plane and table.
- 4 Measuring Instruments
Measuring instruments list and their calibration schedule are shown on Measurement Equipment Configuration.
The brief description are as follows;
- 5 Antennas
The broadband Bi-cog antenna or Biconical and Log periodic antenna is used for measurement on the frequency range 30 – 1000 MHz.
The Double ridged guide antenna is used for frequency higher than 1000 MHz.
- 6 Pre-amplifier
The broadband pre-amplifier is used for radiated emission measurement.
The signal to noise ratio is improved by using pre-amplifier.
- 7 Spectrum Analyzer
The spectrum analyzer is used for preliminary measurement of frequency range 30 – 1000 MHz, and also used for final measurement of higher than 1000 MHz (RBW : 1 MHz).
- 8 EMI Test Receiver
The Quasi-peak detector (IF bandwidth : 120 kHz) built in test receiver is used for final measurement of the frequency 30 – 1000 MHz.
The test receiver is complied with the specification of the CISPR publication 16.
- 9 Turntable
The turntable is capable for EUT weight and rotatable 0 to 360 degree horizontally by remote control in the test room.
- 10 Antenna Mast
The antenna mast is attachable to all antennas described on antenna height is adjustable 1 to 4 meters continuously by remote control at the test room, and antenna polarization is also changed by the remote control.
- 11 Preliminary Measurement
EUT is tested on all operating conditions.
The spectrum analyzer is set max-hold mode and swept during turntable was rotated 0 to 360 degree. Then spectrum chart are plotted out to find the worst emission conditions in configuration, operating mode, or ambient noise notation.

12 Final Measurement

The EUT operated in the condition where maximum emission is found in the preliminary test.

The turntable azimuth(EUT direction) and antenna height are adjusted the position so that maximum field strength is obtained for each frequency spectrum to be measured.

The equipment and cables are arranged or manipulated within the range of the test standard in the above condition.

When the uncertain result was obtained, the measurement is retried by using the half wave dipole antenna instead of the broadband antenna.

TEST EQUIPMENTS

No.	Equipment	Manufacture	Model No.	Serial No.	Cal. Interval	Effective period
1	Broad Band antenna	VULB9168WP	126	Schwarzbeck	1Y	Nov. 30, 22
2	6dB Attenuator	UFA-01	A00040805	TME	1Y	Sep. 30, 22
3	Amplifier	ZX60-3018G	002	Intertek	1Y	Sep. 30, 22
4	RF Switch	ACX-150	A12301501	Intertek	1Y	Sep. 30, 22
5	Double ridged antenna	3115	5044	EMCO	1Y	Jul. 31, 22
6	3 dB Attenuator	6803.17.B	KSR00089		1Y	Sep. 30, 22
7	Amplifier (1-18 GHz)	TPA0118-30	0402	TOYO	1Y	Sep. 30, 22
8	MXE EMI Receiver	N9038A(A.13.58)	MY51210201	Agilent	1Y	Nov. 30, 22
9	Site Attenuation	-	-	-	1Y	Jan. 31, 23
10	SVSWR	-	-	-	1Y	Jan. 31, 23
11	DC Power Supply	Kikusui	PMC35-3A	LE000716	None	None

USED CABLES

No.	Cable	Manufacture	Model No.	Serial No.	Cal. Interval	Effective period
R11	Coaxial Cable	5D-2W(14.0m)	R11	FUJIKURA	1Y	Sep. 30, 22
R1	Coaxial cable	5D-2W(8.0 m)	R1	FUJIKURA	1Y	Sep. 30, 22
R3	Coaxial cable	10D-2W(7.0 m)	R3	FUJIKURA	1Y	Sep. 30, 22
R5	Coaxial cable	RG-5A/U(4.0 m)	R5	FUJIKURA	1Y	Sep. 30, 22
R7	Coaxial cable	RG-5A/U(0.6 m)	R7	FUJIKURA	1Y	Sep. 30, 22
R10	Coaxial cable	5D-2W(1.2 m)	R10	FUJIKURA	1Y	Sep. 30, 22
G1	Coaxial cable(G1)	SUCOFLEX 104(1.0 m)	229603/4	SUHNER	1Y	Sep. 30, 22
G2	Coaxial cable(G2)	5B-048-98-98-5000(5.0m)	111130	Candox	1Y	Sep. 30, 22

MEASUREMENT EQUIPMENT CONFIGURATION

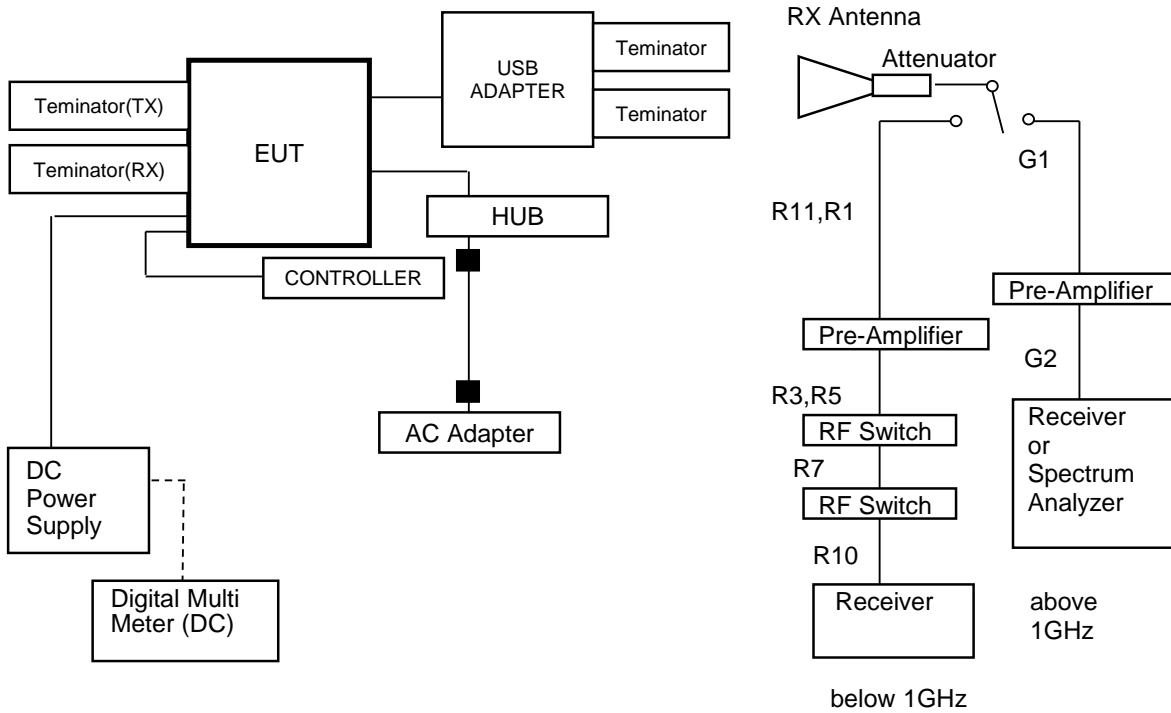

TEST RESULTS

Test date	Jan. 24, 2022 to Jan. 25, 2022
Location	Kashima No.12 Test Site
temperature	19 to 20.0 [degree C]
Humidity Variation	30 to 31 [%]
Atmospheric Pressure	100.0 to 101.6 [kPa]
Test Engineer	Koichi Wagatsuma

Test was carried out for the frequency band of section 10.1
 State the worst case (below).

State : 138.05 MHz Receiver Condition

No.	Frequency (MHz)	Pol	Mode	Reading Level (dBuv)	Factor* (dB)	Emission Level (dBuV/m)	Limit Level (dBuV/m)	Margin (dB)
1	38.94	Hor.		-	-2.8	-	40.0	-
		Ver.		28.4	-2.8	25.6	40.0	14.4
2	153.57	Hor.		30.1	-1.1	29.0	43.5	14.5
		Ver.		-	-1.1	-	43.5	-
3	167.98	Hor.		35.3	-1.3	34.0	43.5	9.5
		Ver.		-	-1.3	-	43.5	-
4	250.00	Hor.		37.1	-1.2	35.9	46.0	10.1
		Ver.		31.0	-1.2	29.8	46.0	16.2
5	500.00	Hor.		24.8	7.6	32.4	46.0	13.6
		Ver.		20.8	7.6	28.4	46.0	17.6
6	1500.00	Hor.	AVG	31.9	-0.9	31.0	54.0	23.0
		Ver.	AVG	31.4	-0.9	30.5	54.0	23.5
7	1997.88	Hor.	AVG	40.4	1.4	41.8	54.0	12.2
		Ver.	AVG	31.1	1.4	32.5	54.0	21.5
8	3330.15	Hor.	AVG	28.9	5.7	34.6	54.0	19.4
		Ver.	AVG	32.6	5.7	38.3	54.0	15.7

There is the margin of 20dB over except for the above points.

* Factor = Antenna, Antenna Pad, Cable, Preamp, (Dist. Conversion)

Emission Level = Reading Level + Factor

Note:

- 1 Measurement distance is 3 metres. (Above 1GHz is 3.9 metres)
- 2 Scanned frequency are 30 to 75000 MHz.
- 3 Highest oscillator frequency is 1500 MHz.
(TXRX UNIT : 219.00MHz)

10.11 Necessary Bandwidth and Emission Bandwidth

REGULATIONS	: FCC Part 2 Section 202 (g) & Federal Register/ Vol.68, No236
-------------	--

Calculation Results

This information was provided by the Applicant or customer.

State : 16K0F3E (Authorized Bandwidth 20 kHz)

Item	Mark		
Maximum Modulation	(M)	3	kHz
Maximum Deviation	(D)	5	kHz
Constant Factor	(K)	1	
Necessary Bandwidth	(Bn)	16	kHz

$B_n = (2 \times M) + (2 \times D \times K)$

- 1.types of modulation of the main carrier : F= Frequency modulation
- 2.nature of signal(s) modulating the main carrier: 3= A single channel containing analog information
- 3.type of information to be transmitted: E= Telephony (including sound broadcasting)

State : 11K0F3E (Authorized Bandwidth 11.25 kHz)

Item	Mark		
Maximum Modulation	(M)	3	kHz
Maximum Deviation	(D)	2.5	kHz
Constant Factor	(K)	1	
Necessary Bandwidth	(Bn)	11	kHz

$B_n = (2 \times M) + (2 \times D \times K)$

- 1.types of modulation of the main carrier : F= Frequency modulation
- 2.nature of signal(s) modulating the main carrier: 3= A single channel containing analog information
- 3.type of information to be transmitted: E= Telephony (including sound broadcasting)

State : 7K60FXE / 7K60FXD / 7K60F7E / 7K60F7D / 7K60F7D / 7K60FXW (9600bps, Authorized Bandwidth 11.25 kHz)

Item	Mark		
Digital information rate	(R)	9600	bps
Peak frequency deviation	(D)	3.024	kHz
Signaling states	(S)	4	
Numerical factor	(K)	0.463	
Necessary Bandwidth	(Bn)	7.6	kHz

$B_n = (R / \log_2 S) + 2 \times D \times K$

- 1.types of modulation of the main carrier : F= Frequency modulation
- 2.nature of signal(s) modulating the main carrier: X= Cases not otherwise covered
- 3.type of information to be transmitted: 7= Two or more channels containing quantized or digital
- E= Telephony (including sound broadcasting)
- D= Data transmission, telemetry, telecommand
- W= Combination of the above

State : 8K30F1E / 8K30F1D / 8K30F7W (4Level FSK / 9600bps, Authorized Bandwidth 11.25 kHz)

Item	Mark		
Digital information rate	(R)	9600	bps
Peak frequency deviation	(D)	3.391	kHz
Signaling states	(S)	4	
Numerical factor	(K)	0.516	
Necessary Bandwidth	(Bn)	8.3	kHz

$$B_n = (R/\log_2 S) + 2x D x K$$

- 1.types of modulation of the main carrier : F= Frequency modulation
 2.nature of signal(s) modulating the main carrier: 1= A single channel containing quantized or digital
 7= Two or more channels containing quantized or digital
 3.type of information to be transmitted: E= Telephony (including sound broadcasting)
 D= Data transmission, telemetry, telecommand
 W= Combination of the above

State : 4K00F1E / 4K00F1D / 4K00F7W (4Level FSK / 4800bps, Authorized Bandwidth 6 kHz)

Item	Mark		
Digital information rate	(R)	4800	bps
Peak frequency deviation	(D)	1.55	kHz
Signaling states	(S)	4	
Numerical factor	(K)	0.516	
Necessary Bandwidth	(Bn)	4	kHz

$$B_n = (R/\log_2 S) + 2x D x K$$

- 1.types of modulation of the main carrier : F= Frequency modulation
 2.nature of signal(s) modulating the main carrier: 1= A single channel containing quantized or digital
 7= Two or more channels containing quantized or digital
 3.type of information to be transmitted: E= Telephony (including sound broadcasting)
 D= Data transmission, telemetry, telecommand
 W= Combination of the above

State : 4K00F2D (CWID, Authorized Bandwidth 6 kHz)

Item	Mark		
Maximum Modulation	(M)	0.8	kHz
Maximum Deviation	(D)	1.2	kHz
Numerical factor	(K)	1	
Necessary Bandwidth	(Bn)	4	kHz

$$B_n = (2xM) + (2x D x K)$$

- 1.types of modulation of the main carrier : F= Frequency modulation
 2.nature of signal(s) modulating the main carrier: 2= A single channel containing quantized or digital
 3.type of information to be transmitted: D= Data transmission, telemetry, telecommand

10.12 99% Occupied Bandwidth

REGULATIONS	: RSS-119 Section 5.5
TEST METHOD/GUIDE	: RSS-Gen Section 6.6

Test Procedure

- 1 The EUT and test equipment were set up as shown on the following page.
- 2 Adjust the test instrument for the following setting:
 - RBW : 1 % to 5 % of the Necessary bandwidth
 - VBW : at least 3 times the RBW
 - Detector : Peak
 - Sweep Time : Auto
 - Trace mode : Max Hold
- 3 Allow trace to fully stabilize.
- 4 Use "Occupied Bandwidth Measurement" function to measure the 99% Occupied Bandwidth.
- 5 Modulate the transmitter with a 2.5 kHz sine wave at an input Level of 16 dB greater than that necessary to produce 50 % of rated system deviation.(Only 16K0F3E, 14K0F3E, 11K0F3E)

Measuring Equipments

No.	Equipment	Manufacture	Model No.	Serial No.	Cal. Interval	Effective period
1	Attenuator (20dB)	Aeroflex/Wenshel	66-20-34	BY4357	1Y	Sep. 30, 22
2	Attenuator (30dB)	Weinschel	WA-29-30-34	8923	1Y	Sep. 30, 22
3	Modulation Analyzer	Hewlett Packard	8901B	3403A04852	1Y	Dec. 31, 22
4	Audio Generator	Anritsu	MG443B	M70150	1Y	Jun. 30, 22
5	Spectrum Analyzer	Agilent	N9030A	US51350220	1Y	Sep. 30, 22
6	DC Power Supply	Daiichi denpa kogyo	GZV4000	90290931	None	None
7	Digital Multi Meter	FLUKE	8846A	9642018	1Y	Jun. 30, 22
8	JIG	HP	ProBook 430 G3	PJPNYOKL0147	None	None
9	Balance Cable	Nicoon	3D-2V	KSR00092	1Y	Sep. 30, 22
10	Coaxial Cable	Pacific custom	RG-58 C/U	AM90C04	1Y	Mar. 31, 22
11	Coaxial Cable	Suhner	SUCOFLEX104	F0000019	1Y	Mar. 31, 22

Measuring Equipment Configuration

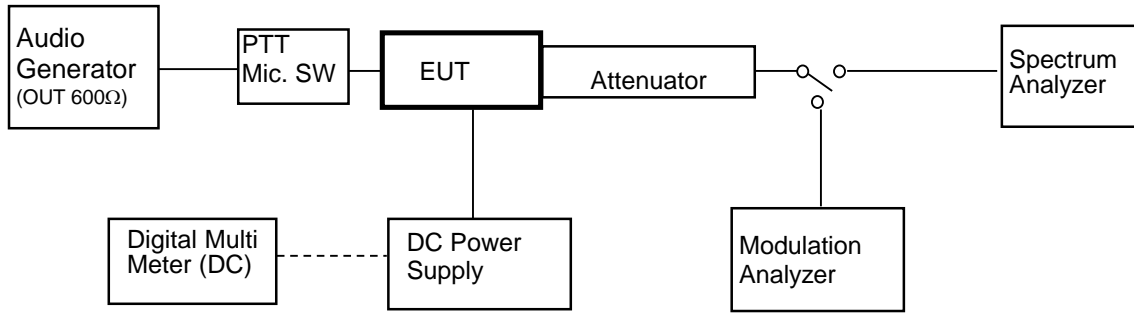

<NXDN and CW ID Modulation Case>

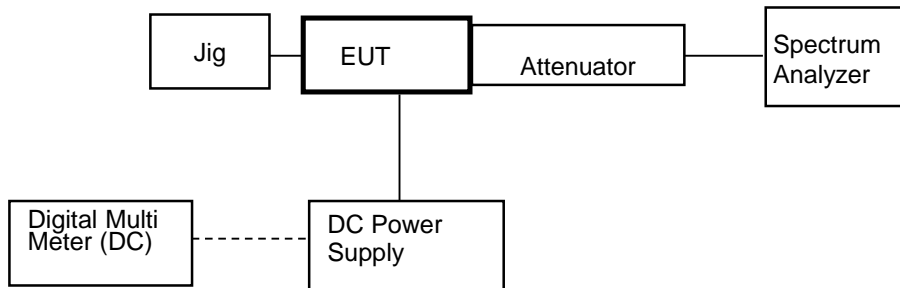

Test Results

Test date	Jan 27, 2022		
Location	Kashima No.12 Test Site		
temperature	24.3	[degree C]	
Humidity Variation	35.0	[%]	
Atmospheric Pressure	101.4	[kPa]	
Test Engineer	Koichi Wagatsuma		

Emission Designation	Frequency (MHz)	99% Occupied Bandwidth (kHz)	Authorized bandwidth (kHz)
16K0F3E	138.05	14.931	20
	162.05	14.932	
	173.95	14.889	
11K0F3E	138.05	9.968	20
	162.05	9.968	
	173.95	9.959	
7K60FXD/FXE/F7E/F7D/F7W/FXW	138.05	7.817	11.25
	162.05	7.878	
	173.95	7.890	
8K30F1E/F1D/F7W	138.05	7.684	11.25
	162.05	7.701	
	173.95	7.656	
4K00F1E / F1D / F7W	138.05	3.548	6
	162.05	3.574	
	173.95	3.562	
4K00F2D	138.05	3.306	6
	162.05	3.309	
	173.95	3.307	

Ferquency (MHz)	Emission Designation	
	16K0F3E	11K0F3E
138.05	<p>Agilent Spectrum Analyzer - Occupied BW Center Freq: 138.050000 MHz Ref: 0.00 dBm Center Freq: 138.050000 MHz Trig: Free Run Avg Hold: 5000 Radio Stid: None Radio Device: BTS Span: 50 kHz Res BW: 300 Hz VBW: 3 kHz Sweep: 312.5 ms Occupied Bandwidth: 14.931 kHz Total Power: -0.88 dBm Transmit Freq Error: 66 Hz OBW Power: 99.00 % x dB Bandwidth: 15.41 kHz x dB: -20.00 dB</p>	<p>Agilent Spectrum Analyzer - Occupied BW Center Freq: 138.050000 MHz Ref: 0.00 dBm Center Freq: 138.050000 MHz Trig: Free Run Avg Hold: 5000 Radio Stid: None Radio Device: BTS Span: 50 kHz Res BW: 110 Hz VBW: 1.1 kHz Sweep: FFT Occupied Bandwidth: 9.968 kHz Total Power: -1.33 dBm Transmit Freq Error: 55 Hz OBW Power: 99.00 % x dB Bandwidth: 10.05 kHz x dB: -20.00 dB</p>
162.05	<p>Agilent Spectrum Analyzer - Occupied BW Center Freq: 162.050000 MHz Ref: 0.00 dBm Center Freq: 162.050000 MHz Trig: Free Run Avg Hold: 5000 Radio Stid: None Radio Device: BTS Span: 50 kHz Res BW: 300 Hz VBW: 3 kHz Sweep: 312.5 ms Occupied Bandwidth: 14.932 kHz Total Power: -0.94 dBm Transmit Freq Error: 62 Hz OBW Power: 99.00 % x dB Bandwidth: 15.41 kHz x dB: -20.00 dB</p>	<p>Agilent Spectrum Analyzer - Occupied BW Center Freq: 162.050000 MHz Ref: 0.00 dBm Center Freq: 162.050000 MHz Trig: Free Run Avg Hold: 5000 Radio Stid: None Radio Device: BTS Span: 50 kHz Res BW: 110 Hz VBW: 1.1 kHz Sweep: FFT Occupied Bandwidth: 9.968 kHz Total Power: -1.38 dBm Transmit Freq Error: 55 Hz OBW Power: 99.00 % x dB Bandwidth: 10.05 kHz x dB: -20.00 dB</p>
173.95	<p>Agilent Spectrum Analyzer - Occupied BW Center Freq: 173.950000 MHz Ref: 0.00 dBm Center Freq: 173.950000 MHz Trig: Free Run Avg Hold: 5000 Radio Stid: None Radio Device: BTS Span: 50 kHz Res BW: 300 Hz VBW: 3 kHz Sweep: 312.5 ms Occupied Bandwidth: 14.889 kHz Total Power: -0.88 dBm Transmit Freq Error: 60 Hz OBW Power: 99.00 % x dB Bandwidth: 15.40 kHz x dB: -20.00 dB</p>	<p>Agilent Spectrum Analyzer - Occupied BW Center Freq: 173.950000 MHz Ref: 0.00 dBm Center Freq: 173.950000 MHz Trig: Free Run Avg Hold: 5000 Radio Stid: None Radio Device: BTS Span: 50 kHz Res BW: 110 Hz VBW: 1.1 kHz Sweep: FFT Occupied Bandwidth: 9.959 kHz Total Power: -1.34 dBm Transmit Freq Error: 54 Hz OBW Power: 99.00 % x dB Bandwidth: 10.03 kHz x dB: -20.00 dB</p>

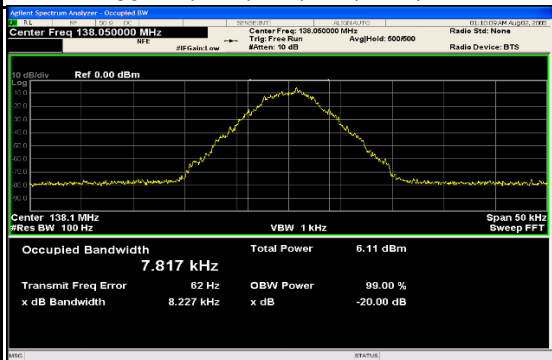
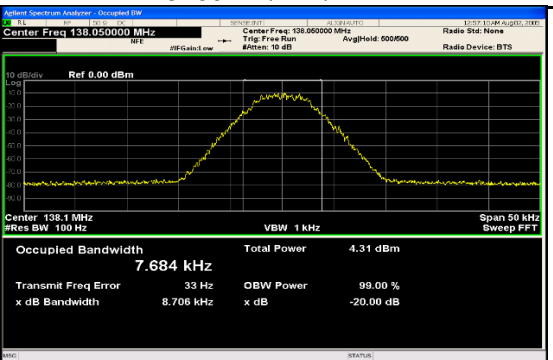
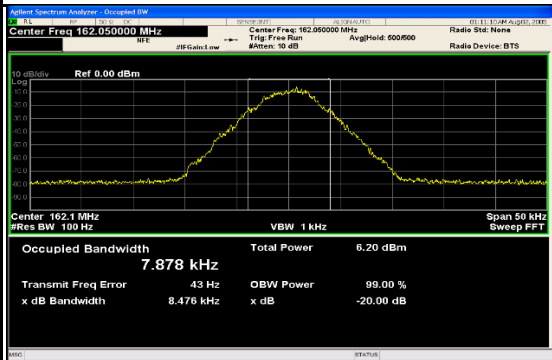
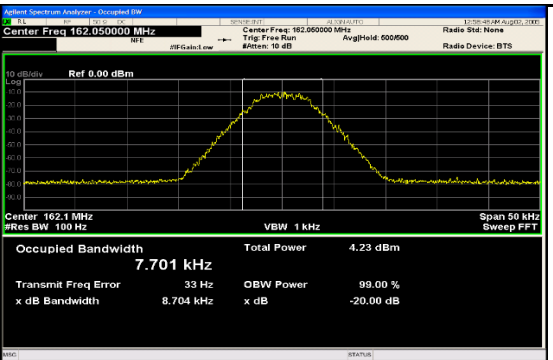
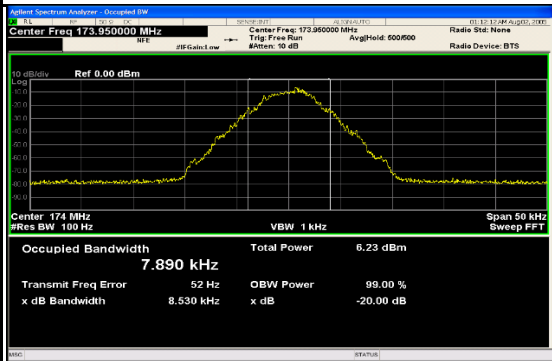
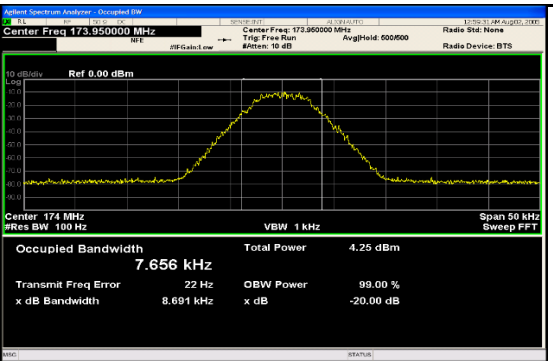
Ferquency (MHz)	Emission Designation	
	7K60FXD/FXE/F7E/F7D/F7W/FXW	8K30F1E/F1D/F7W
138.05	 <p>Agilent Spectrum Analyzer - Occupied BW Center Freq: 138.050000 MHz Occupied Bandwidth: 7.817 kHz Total Power: 6.11 dBm</p>	 <p>Agilent Spectrum Analyzer - Occupied BW Center Freq: 138.050000 MHz Occupied Bandwidth: 7.684 kHz Total Power: 4.31 dBm</p>
162.05	 <p>Agilent Spectrum Analyzer - Occupied BW Center Freq: 162.050000 MHz Occupied Bandwidth: 7.878 kHz Total Power: 6.20 dBm</p>	 <p>Agilent Spectrum Analyzer - Occupied BW Center Freq: 162.050000 MHz Occupied Bandwidth: 7.701 kHz Total Power: 4.23 dBm</p>
173.95	 <p>Agilent Spectrum Analyzer - Occupied BW Center Freq: 173.950000 MHz Occupied Bandwidth: 7.890 kHz Total Power: 6.23 dBm</p>	 <p>Agilent Spectrum Analyzer - Occupied BW Center Freq: 173.950000 MHz Occupied Bandwidth: 7.656 kHz Total Power: 4.25 dBm</p>

Ferquency (MHz)	Emission Designation	
	4K00F1E / F1D / F7W	4K00F2D
138.05	<p>Agilent Spectrum Analyzer - Occupied BW Center Freq: 138.050000 MHz Occupied Bandwidth: 3.548 kHz Total Power: 5.07 dBm Transmit Freq Error: -13 Hz x dB Bandwidth: 4.244 kHz</p>	<p>Agilent Spectrum Analyzer - Occupied BW Center Freq: 138.050000 MHz Occupied Bandwidth: 3.306 kHz Total Power: -1.41 dBm Transmit Freq Error: 10 Hz x dB Bandwidth: 3.380 kHz</p>
162.05	<p>Agilent Spectrum Analyzer - Occupied BW Center Freq: 162.050000 MHz Occupied Bandwidth: 3.574 kHz Total Power: 4.94 dBm Transmit Freq Error: -22 Hz x dB Bandwidth: 4.251 kHz</p>	<p>Agilent Spectrum Analyzer - Occupied BW Center Freq: 162.050000 MHz Occupied Bandwidth: 3.309 kHz Total Power: -1.61 dBm Transmit Freq Error: 10 Hz x dB Bandwidth: 3.382 kHz</p>
173.95	<p>Agilent Spectrum Analyzer - Occupied BW Center Freq: 173.950000 MHz Occupied Bandwidth: 3.562 kHz Total Power: 4.97 dBm Transmit Freq Error: -21 Hz x dB Bandwidth: 4.244 kHz</p>	<p>Agilent Spectrum Analyzer - Occupied BW Center Freq: 173.950000 MHz Occupied Bandwidth: 3.307 kHz Total Power: -1.64 dBm Transmit Freq Error: 10 Hz x dB Bandwidth: 3.381 kHz</p>