

KENWOOD

TS-890S

INSTRUCTION MANUAL

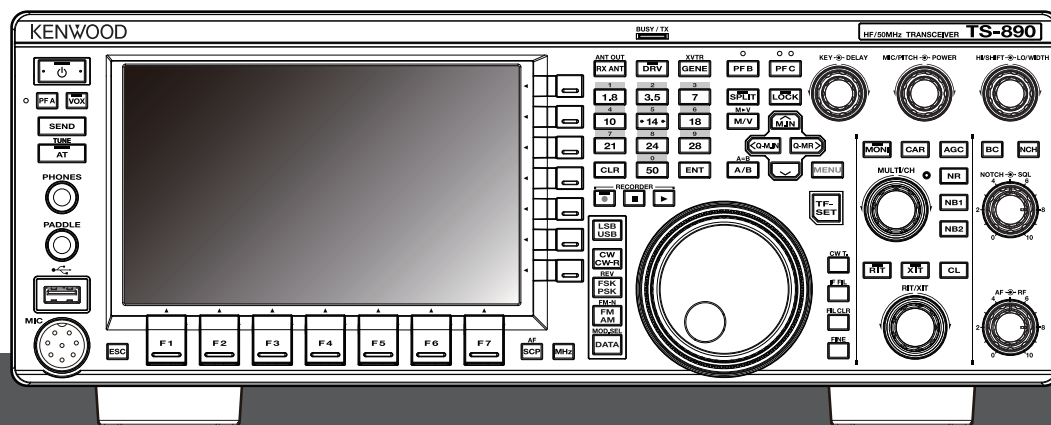

JVCKENWOOD Corporation



BEFORE USING

Thank You

Thank you for choosing this **KENWOOD** TS-890S transceiver.

FEATURES

- A high-end and practical transceiver with basic reception performance that exceeds its class, with multiple functions and with a feel of TS-990
- Incorporates a 7" TFT color display for comfortable centralized control of operations using various information: auto scroll mode, filter scope, TX bar meter, etc.
- Top-class basic reception performance
Provides third-order intermodulation DR: 110 dB, RMDR: 112 dB and BDR**: 150 dB (Measurement example at 2 kHz detuning: RX frequency 14.2 MHz, MODE CW, BW 500 Hz, PRE AMP OFF)
*RMDR (Reciprocal Mixing Dynamic Range), **BDR (Blocking Dynamic Range)
- HF band +50 MHz
- 100 W heavy duty output power (50 W for TS-890D)
- Built-in automatic antenna tuner (relay system, high speed matching)
- SSB, CW, FSK (RTTY), PSK31 (BPSK/QPSK), PSK63 (BPSK), AM, FM
- Capable of FSK, PSK31/63 as well as CW decoding/encoding
- Equipped with two 32-bit floating-point arithmetic DSPs for transmission and reception and scope display
- Equipped with LAN, USB and COM ports
- External display connection (via DVI-I connector)
- Capable of remote control operation (direct IP connection) without using a host PC. Radio Control Program (ARCP-890) and Radio Host Program (ARHP-890) are also provided free as before
- Supports USB audio. The speaker and the microphone of a PC can be used during the USB audio operation by using ARUA-10 (Freeware)

Supplied Accessories

The following accessories are supplied with the transceiver. After carefully unpacking the transceiver, identify the accessories listed in the table.

Item	Quantity	
	K-type	E-type
DC power cable	1	1
7-pin DIN plug (For REMOTE connector)	1	1
13-pin DIN plug (For ACC2 connector)	1	1
Fuse 4 A	1	1
Fuse 25 A	1	1
Instruction Manual	English	1
	French	1
	Spanish	–
	Italian	–
	German	–
	Dutch	–
Schematic diagram	3	3
Warranty Card	1	1



- We recommend you keep the box and packing materials in case you need to repack the transceiver in the future.
- Do not put the plastic bag used for packing of this equipment on the place which reaches a small child's hand. It will become a cause of suffocation if it wears flatly.

Market Codes

K-type: : The Americas

E-type: : Europe

The market code is shown on the carton box.

Refer to the specifications for information on the available operating frequencies.

Copyrights for This Manual

- JVC KENWOOD Corporation shall own all copyrights and other intellectual properties for the product and the software and for all manuals and documents attached to the product and the software.
- A user is required to obtain approval from JVC KENWOOD corporation, in writing, prior to redistributing this document on a personal web page or via packet communication.
- A user is prohibited from assigning, renting, leasing or reselling the document.
- JVC KENWOOD Corporation does not warrant that quality and functions described in this manual comply with each user's purpose of use and, unless specifically described in this manual, JVC KENWOOD Corporation shall be free from any responsibility for any defects and indemnities for any damages or losses.

Software Copyrights

The title to and ownership of copyrights for software, including but not limited to the firmware that may be distributed individually, to be embedded in KENWOOD product memories, are reserved for JVC KENWOOD Corporation.

Any modifying, reverse engineering, copying, reproducing or disclosing on an Internet website of the software is strictly prohibited.

A user is required to obtain approval from JVC KENWOOD corporation, in writing, prior to redistributing this manual on a personal web page or via packet communication.

Furthermore, any reselling, assigning or transferring of the software is also strictly prohibited without embedding the software in KENWOOD product memories.

Software License Agreement

Software License Agreement contains the terms and conditions of use of the software embedded in or used with the transceiver. A user is entitled to use the software subject to the acceptance and agreement of this Software License Agreement by the user. Also, this Software License Agreement stipulates the terms and conditions of use of this software embedded in or used with the transceiver, and a user has the right to use the transceiver with the software embedded subject to the applicable laws and regulations, the description and defined in this manual and the warranty card.

The Software License Agreement can be displayed in the menu below. (Refer to Chapter 3 for operation of menu.)

Advanced menu [24] "Software License Agreement"

Important Notices Concerning the Software License Agreement

The software embedded in this transceiver consists of a multiple number of and individual software components. Title to and ownership of copyrights for each software component is reserved for JVC KENWOOD Corporation and the respective bona fide holder.

This product employs the software component in accordance with the End User License Agreement (hereinafter referred to as the “EULA”) stipulated by JVC KENWOOD Corporation and/or the respective bona fide holder.

There is free software stipulated and governed by the “EULA”, and this, a distribution condition of the software component in the executable format under the terms and conditions contained in the GNU General Public License or Lesser General Public License (hereinafter referred to as the “GPL/LGPL”), requires to make the source code for the relevant software components available. Access the URL below for details of the software component stipulated in the “GPL/LGPL”.

<http://www2.jvckenwood.com/gpl/index.html>

Important notice about software can be displayed in the menu below. (Refer to Chapter 3 for operation of menu.)

Advanced menu [25] “Important Notices concerning Free Open Source”

About the GPL/ LPGL License

The GPL / LGPL license agreement can be displayed in the menu below. (Refer to Chapter 3 for operation of menu.)

Advanced menu [26] “About Various Software License Agreements”

This product includes “Ubiquitous QuickBoot™” technology developed by Ubiquitous Corp.

Ubiquitous QuickBoot™ is a trademark of Ubiquitous Corp. Copyright © 2018 Ubiquitous Corp. All rights reserved.



Copyrights for Recorded Audio

The broadcast content recorded in this transceiver may not be reused, except for the personal use, without prior consent of the right holder under the copyright laws.

Trademarks

KENWOOD is a registered trade mark of JVC KENWOOD Corporation.

All other product names referenced herein are trademarks or registered trademarks of their respective manufacturers. Marks such as ™ and ® are omitted in the text of body.

Indemnity

- JVC KENWOOD Corporation takes all appropriate measures to ensure all descriptions in this manual are accurate; however, this manual may still contain typographical errors (“typos”) and expressions that are misleading. JVC KENWOOD Corporation is entirely free from any responsibilities arising from any losses or damages caused by such typos or expressions. JVC KENWOOD Corporation has the right to change or improve the product specifications, etc., described in this manual without prior notice. JVC KENWOOD Corporation is entirely free from any responsibilities for any losses or damages caused by such changes and improvements.
- JVC KENWOOD Corporation is entirely free from any responsibilities for any failures, damages or losses arising from, or in connection with, use of the transceiver with or connected to any external equipment.
- JVC KENWOOD Corporation does not warrant that the quality and functions described in this manual comply with your purpose of use and, unless specifically described in this manual, JVC KENWOOD Corporation shall be free from any responsibilities for any defects and indemnities for any damages or losses. Selection and installation of any external equipment shall be done at your own risk. You are fully responsible for the use and effects of external equipment.
- JVC KENWOOD Corporation shall be free from any responsibilities for any incidental losses or damages, such as missing communications or call opportunities caused by a failure or performance error of the transceiver.

Your Queries about External Devices or PC Connected to the Transceiver

JVC KENWOOD Corporation are pleased to answer, within the scope of corporate efforts we can provide, your queries about your operation of this transceiver. Please bear in mind that we cannot answer any and all technical questions regarding methods of connection to, configuration for and operation of any external device and PC beyond our knowledge.

Handling Your Important Data

There is always a risk of losing your important data due to transceiver failure, occurrence of an unforeseen contingency, erroneous operation or faulty behavior of the transceiver. The data, such as the operating information, recorded audio, messages, configuration data, logs, etc., must be backed up as necessary by yourself and stored in the external storage device such as a USB flash drive.

Precautions

Please observe the following precautions to prevent fire, personal injury, and transceiver damage:

- Connect the transceiver only to a power source as described in this manual or as marked on the transceiver itself.
- Route all power cables safely. Ensure the power cables can neither be stepped upon nor pinched by items placed near or against the cables. Pay particular attention to locations near AC receptacles, AC outlet strips, and points of entry to the transceiver.
- Take care not to drop objects or spill liquid into the transceiver through enclosure openings. Metal objects, such as hairpins or needles, inserted into the transceiver may contact voltages resulting in serious electrical shocks. Never permit children to insert any objects into the transceiver.
- Do not attempt to defeat methods used for grounding and electrical polarization in the transceiver, particularly involving the power input cable.
- Adequately ground all outdoor antennas for this transceiver using approved methods. Grounding helps protect against voltage surges caused by lightning. It also reduces the chance of a build-up of static charge.

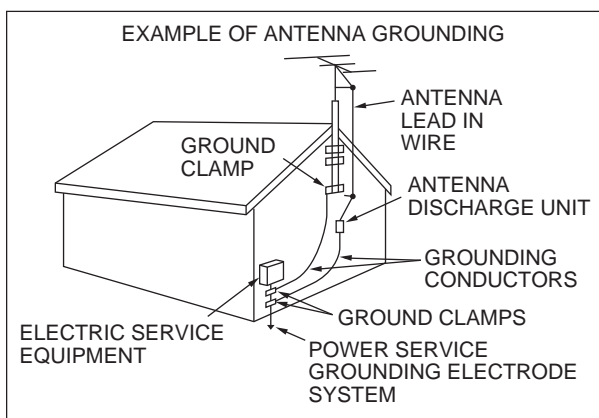

- Minimum recommended distance for an outdoor antenna from power lines is one and one-half times the vertical height of the associated antenna support structure. This distance allows adequate clearance from the power lines if the support structure fails for any reason.
- Locate the transceiver so as not to interfere with its ventilation. Do not place books or other equipment on the transceiver that may impede the free movement of air. Allow a minimum of 10 cm (4 inches) between the rear of the transceiver and the wall or operating desk shelf.
- Do not use the transceiver near water or sources of moisture. For example, avoid use near a bathtub, sink, swimming pool, or in a damp basement or attic.
- The presence of an unusual odor or smoke is often a sign of trouble. Immediately turn the power OFF and remove the power cable. Contact a **KENWOOD** service station or your dealer for advice.

- Locate the transceiver away from heat sources such as a radiator, stove, amplifier or other devices that produce substantial amounts of heat.
- Do not use volatile solvents such as alcohol, paint thinner, gasoline, or benzene to clean the cabinet of the transceiver. Use only a clean cloth with warm water or a mild detergent.
- Disconnect the input power cable from the power source when the transceiver is not used for long periods of time.
- Remove the transceiver's enclosure only to do accessory installations described in this manual or accessory manuals. Follow provided instructions carefully, to avoid electrical shocks. If unfamiliar with this type of work, seek assistance from an experienced individual, or have a professional technician do the task.
- Enlist the services of qualified personnel in the following cases:
 - a) The power supply or plug is damaged.
 - b) Objects have fallen into or liquid has spilled into the transceiver.
 - c) The transceiver has been exposed to rain.
 - d) The transceiver is operating abnormally or performance has seriously degraded.
 - e) The transceiver has been dropped or the enclosure damaged.
- Do not place the unit in excessively dusty and/or humid areas, nor on unstable surfaces.
- HF/ 50/ 70 MHz mobile antennas are larger and heavier than VHF/ UHF antennas. Therefore, use a strong and rigid mount to safely and securely install the HF/ 50/ 70 MHz mobile antenna.
- Do not put the plastic bag used for packing of this equipment on the place which reaches a small child's hand. It will become a cause of suffocation if it wears flatly.
- Turn the transceiver power off in the following locations: In explosive atmospheres (inflammable gas, dust particles, metallic powders, grain powders, etc.)

About Liquid Crystal Display

- Brightness of the LCD screen may appear uneven depending on the content displayed. This is not a malfunction.
- The LCD is manufactured using high-density technology to achieve more than 99.99 % of effective pixels. Less than 0.01 % of the pixels may not be lit or may remain lit all the time. This is not a malfunction.
- When using this product in a cold region or when the temperature of this unit or its surroundings is extremely low, it may take a few minutes for the LCD to reach the normal level of brightness after turning on the power. This is not a malfunction. When this occurs, turn off the power and allow the surrounding environment to reach the ambient temperature (10 °C to 30 °C or 32°F to 86°F) before using the unit.
- If you accidentally damaged the LCD display and the liquid in the LCD display splashes and gets into your eyes or mouth, rinse thoroughly with water immediately and seek medical attention. And if the liquid splashes on your clothes or skin, wipe off immediately with alcohol etc. Leaving it as is will harm your skin or damage your clothes.

BEFORE USING

Notice to the User

One or more of the following statements may be applicable for this equipment.

FCC WARNING

This equipment generates or uses radio frequency energy. Changes or modifications to this equipment may cause harmful interference unless the modifications are expressly approved by the party responsible/ JVC KENWOOD. The user could lose the authority to operate this equipment if an unauthorized change or modification is made.

INFORMATION TO THE DIGITAL DEVICE USER REQUIRED BY THE FCC

This equipment has been tested and found to comply with the limits for a Class B digital device, pursuant to Part 15 of the FCC Rules. These limits are designed to provide reasonable protection against harmful interference in a residential installation.

This equipment generates, uses and can generate radio frequency energy and, if not installed and used in accordance with the instructions, may cause harmful interference to radio communications. However, there is no guarantee that the interference will not occur in a particular installation. If this equipment does cause harmful interference to radio or television reception, which can be determined by turning the equipment off and on, the user is encouraged to try to correct the interference by one or more of the following measures:

- Reorient or relocate the receiving antenna.
- Increase the separation between the equipment and receiver.
- Connect the equipment to an outlet on a circuit different from that to which the receiver is connected.
- Consult the dealer for technical assistance.

This product is designed for connection to an IT power distribution system.

Notification

This equipment complies with the essential requirements of Directive 2014/53/EU.



Restrictions

This equipment requires a licence and is intended for use in the countries below.

AT	BE	DK	FI	FR	DE	GR	IS	IE
IT	LI	LU	NL	NO	PT	ES	SE	CH
GB	CY	CZ	EE	HU	LV	LT	MT	PL
SK	SI	BG	RO	HR	TR			

ISO3166

Information on Disposal of Old Electrical and Electronic Equipment and Batteries (applicable for countries that have adopted separate waste collection systems)

Products and batteries with the symbol (crossed-out wheeled bin) cannot be disposed as household waste.

Old electrical and electronic equipment and batteries should be recycled at a facility capable of handling these items and their waste byproducts.

Contact your local authority for details in locating a recycle facility nearest to you.

Proper recycling and waste disposal will help conserve resources whilst preventing detrimental effects on our health and the environment.

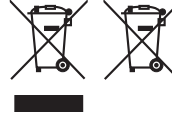

Firmware Copyrights

The title to and ownership of copyrights for firmware embedded in KENWOOD product memories are reserved for JVC KENWOOD Corporation.

Bu ürün 28300 sayılı Resmi Gazete'de yayımlanan Atık Elektrikli ve Elektronik Eşyaların Kontrolü Yönetmeliğe uygun olarak üretilmiştir.

Eski Elektrikli ve Elektronik Cihazların ve Pillerin İmhası Hakkında Bilgi (ayrı atık toplama sistemlerine sahip olan ülkelerde geçerlidir)

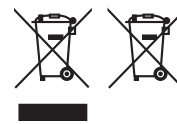

Bu sembolü (üzeri çizili çöp bidonu) içeren ürün ve piller evsel atık çöpleri ile birlikte atılamaz.

Kullanılmış elektrikli ve elektronik cihaz ve piller, bu tür maddeleri ve bunların yan ürünlerini işlemeye elverişli bir geri kazanım tesisine gönderilmelidir.

Size en yakın geri kazanım tesisinin konumunu öğrenmek üzere yerel yetkililerinize danışın.

Doğru geri kazanım ve atık uzaklaştırma yöntemleri, sadece öz kaynakların korunmasına yardımcı olmakla kalmayıp ayrıca sağlığınıza ve çevreye olacak zararlı etkilerini engellemeye yardımcı olur.

This device complies with Industry Canada license exempt RSS standard(s). Operation is subject to the following two conditions : (1) this device may not cause interference, and (2) this device must accept any interference, including interference that may cause undesired operation of the device.

CONTENTS

BEFORE USING

CONTENTS

1 INSTALLATION AND CONNECTION

Installation	1-1
Antenna Installation and Connection	1-1
Ground Connection	1-1
Installation of Lightning Arrestors	1-1
Connection of Regulated DC Power Supply	1-1
Using the Auxiliary Support	1-1
Torque Adjustment with Tuning Control	1-2
Connection of Accessories (Front Panel)	1-2
Connection of Accessories (Rear Panel)	1-3
Connection with Data Communication Equipment	1-4
PC Connection	1-4
TNC Connection	1-4
Terminal Descriptions	1-5

2 NAMES AND FUNCTIONS OF PARTS

Front Panel	2-1
Panel Key Behavior	2-1
List of Function Key Behaviors (Standard Mode Screen)	2-4
Rear Panel	2-7
Microphone (Optional)	2-8
Screen	2-9

3 MENU

Menu Operation	3-1
Calling Up a Menu	3-1
Calling Up a Sub-Menu	3-1
Advanced Menu	3-1
Common Menu Screen Operations	3-2
Exiting the Menu	3-2
Switching between the CONFIG A and CONFIG B Operating Environments	3-2
Menu Items	3-3

4 BASIC OPERATIONS

Turning ON/OFF the Power	4-1
Screen Display Settings	4-1
Changing the Background Color	4-1
Changing the Type of Function Key Display	4-1
Changing the Frequency Display Font Type	4-1
Dimmer	4-2
Switching the Brightness Level	4-2
Adjusting the Dimmer Level	4-2
Adjusting AF Gain	4-2
Adjusting RF Gain	4-2
Adjusting the Squelch Level	4-2
Selecting VFO A/ B	4-2
Selecting an Operating Band	4-3
Changing the Number of Band Memories	4-3
Selecting an Operating Mode	4-4
SSB (LSB-USB) Mode	4-4
CW/ CW-R Mode	4-4
FSK/ FSK-R/ PSK/ PSK-R Mode	4-4
FM/ AM Mode	4-4
DATA Mode	4-4
Auto Mode	4-4
Turning ON/OFF Auto Mode	4-4
Configuring Auto Mode Frequency Points	4-4
Adjustment of Frequencies	4-5
Adjustment Using the Tuning Control	4-5
Adjustment Using the Microphone Key	4-5
FINE Tuning	4-5

Configuring the Number of Steps per Revolution of the Tuning Control	4-5
Configuring the Fast Forward Rate of the Tuning Control	4-5
Configuring the Sensitivity for Starting the Fast Forward Operation	4-5
Frequency Adjustment Using the [MULTI/CH] Control	4-6
Rounding the Frequency	4-6
Configuring the Frequency Step Size of the [MULTI/CH] Control	4-6
Switching the AM Broadcast Frequency in 9 kHz Steps	4-6
Adjusting Frequency in MHz Steps	4-6
Configuring the Frequency Step Size in MHz	4-6
Direct Input of Frequency Value	4-6
Frequency Input History	4-7
Frequency Lock	4-7
Lock Target	4-7
Transmission	4-7
Audio Transmission	4-7
CW Transmission	4-7
Adjusting Microphone Gain	4-7
Adjusting TX Output Power	4-8
Fine Adjustment of TX Output Power	4-8
TX Output Power Limiter	4-8
Turning ON/OFF TX Output Power Limiter	4-8
Configuring the TX Output Power Limiter	4-8
Meter	4-9
Changing the Meter Type	4-9
Changing the Meter Type from the Menu	4-9
Changing the Meter Type via Touchscreen Operation	4-9
Switching between TX Meters	4-9
FM Mode S-meter Sensitivity	4-9
Analog Meter Response	4-9
Meter with Peak Hold	4-9
S Meter Scale	4-9
TX Meter (Digital)	4-10
Switching the Antenna	4-10
RX Antenna	4-10
Drive Output (DRV)	4-10
Turning ON/OFF Drive Output	4-10
Adjusting the Drive Output Level	4-10
Built-in Antenna Tuner	4-11
Impedance Matching with the Antenna	4-11
Preset	4-11
Holding Transmission at the End of Antenna Tuning	4-11
Switching Antenna Tuner Behavior during Reception	4-12
Configuring the Built-in Antenna Tuner Behavior for Each Band ...	4-12
Connecting the External Antenna Tuner AT-300	4-12

5 COMMUNICATING AIDS

Split Operation	5-1
Direct Input of Frequency Difference Specified by DX Station	5-1
Turning the Tuning Control to Search for a TX Frequency	5-1
Δ F Display	5-1
Changing the split frequency using the [RIT/XIT] control	5-1
Configuring the Band Direct Key during Split Operation	5-1
TF-SET (Setting the TX Frequency)	5-2
AGC	5-2
Switching the AGC Time Constant	5-2
Adjusting the AGC Time Constant Preset Value	5-2
AGC OFF	5-3
AGC Quick Recovery	5-3
RX Equalizer	5-4
Turning ON/OFF RX Equalizer	5-4
Selecting an RX Equalizer Characteristic	5-4
Adjusting the Equalizer Characteristics	5-4
Copying Equalizer Data	5-4
Saving Equalizer Data	5-5
Reading Equalizer Data	5-5

CONTENTS

Preamplifier	5-6	Saving RTTY Communication Logs	5-18
RX Monitor	5-6	Adjusting the RTTY Decode Threshold Level	5-18
SWL (BCL) Mode	5-6	FFT Scope/X-Y Scope Display Setting	5-18
Band Switching in the SWL Mode (VFO Mode)	5-6	FFT Scope Waveform Averaging	5-18
Transmission in Data Mode	5-7	Selecting a Waterfall Display Type	5-19
Transmission via PTT Switch, SS Terminal and SEND	5-7	Tracking Speed/Density Level of X-Y Scope	5-19
Transmission via DATA PTT or DATA SEND	5-7	Transmitting Character Strings Using USB Keyboard	5-19
RIT/XIT	5-7	Transmitting the Input Character String Immediately	5-19
RIT (Receiver Incremental Tuning)	5-7	Temporarily Placing Character Strings in the TX Details Display Area before Transmission	5-19
RIT Shift	5-7	RTTY Message Memory	5-20
XIT (Transmitter Incremental Tuning)	5-7	Registering RTTY Messages	5-20
XIT Shift	5-7	Configuring Auto TX/RX for the RTTY Message Memory	5-20
Adjusting the Carrier Level	5-8	Transmitting Character Strings from the RTTY Message Memory	5-21
Operation in CW Mode	5-8	Settings Related to RTTY Encode/Decode	5-21
CW Break-in	5-8	Enabling Decode UOS (Unshift on Space)	5-21
Turning ON/OFF Break-in	5-8	Newline Code Setting	5-21
Adjusting the Break-in Mode and Break-in Delay Time	5-9	Diddle Operation	5-21
Adjusting the Sidetone and Pitch Frequency	5-9	Encode UOS	5-21
Adjusting the Sidetone Volume	5-9	Sending a Newline Code at the Start or End of a Transmission	5-21
CW Rise Time	5-9	RTTY Parameters	5-21
Auto Zero-in (CW Auto Tune)	5-9	Configuring the Mark Frequency	5-21
CW BFO Sideband	5-9	Configuring the RTTY Shift Width	5-21
CW Automatic Transmission from SSB Mode	5-9	Frequency Reverse in RTTY Mode	5-22
Frequency Offset when Shifting from SSB to CW Mode	5-10	Operating RTTY Using an External Device	5-22
Encoding/Decoding Morse Code	5-10	ACC 2 Keying Polarity Setting	5-22
Displaying the CW Communication Screen	5-10	Audio Peak Filter	5-22
Operating the CW Communication Screen	5-10	PSK Operation	5-22
Indicator Displays	5-10	Displaying the PSK Communication Screen	5-22
Adjusting the Decode Threshold Level	5-11	Switching between the FFT Scope and Vectorscope Display ...	5-22
Decode Filter	5-11	Operating the PSK Communication Screen	5-23
Transmitting Character Strings via USB Keyboard Operation	5-11	Indicator Displays	5-23
Encoding Character Strings Using the CW Message Memory	5-12	Saving PSK Communication Logs	5-23
Paddle Operation on CW Communication Screen	5-12	Adjusting the PSK Decode Threshold Level	5-23
Paddle Operation when the TX Details Display Area is Empty ..	5-12	FFT Scope/Vectorscope Display Setting	5-24
Paddle Operation during Encoding of Character Strings in the TX Details Display Area	5-12	FFT Scope Waveform Averaging	5-24
Saving CW Communication Logs	5-12	Selecting a Waterfall Display Type	5-24
Electronic Keyer	5-13	Vectorscope	5-24
Selecting the PADDLE Jack Behavior	5-13	AFC (Automatic Frequency Control)	5-24
Selecting the KEY Jack Behavior	5-13	Configuring the AFC Tuning Range	5-24
Operation Mode of the Electronic Keyer	5-13	NET	5-24
Reversing Dot and Dash	5-13	Switching between BPSK and QPSK	5-24
Mic Paddle Mode	5-13	Switching between PSK31 and PSK63	5-25
Adjusting the Keying Speed	5-13	Transmitting Character Strings from USB Keyboard	5-25
Changing the Weighting	5-14	Transmitting the Input Character String Immediately	5-25
Weight Ratio Reverse	5-14	Temporarily Placing Character Strings in the Character String Buffer before Transmission	5-25
CW Message Memory	5-14	PSK Message Memory	5-26
Switching the Method of Registering CW Messages	5-14	Registering Messages	5-26
Registering CW Messages via Text Input	5-14	Configuring Auto TX/RX for the PSK Message Memory	5-26
Registering CW Messages via Paddle Operation	5-15	Transmitting Character Strings from the PSK Message Memory ..	5-27
Contest Number	5-15	Settings Related to PSK	5-27
Configuring the Starting Contest Number (Text Input Only)	5-15	Configuring the PSK Tone Frequency	5-27
Selecting a Method for Sending out Contest Number (Text Input Only)	5-15	Reversing the Direction of Phase Change in the QPSK Mode ..	5-27
Selecting a Channel for Counting up the Contest Numbers (Text Input Only)	5-16	PSK Operation Using a PC	5-27
Decrementing the Contest Number (Text Input Only)	5-16	Communication Log	5-27
Playing/Transmitting CW Messages	5-16	Selecting a Log File Format	5-27
Repeat Playback of CW Messages	5-16	Displaying a Time Stamp	5-28
Configuring the Repeat Playback Interval	5-17	Selecting a Time Stamp Type	5-28
Interrupt Keying	5-17	Selecting a Clock Type	5-28
Deleting a CW Message	5-17	Editing the Communication Log File	5-28
RTTY Operation	5-17	Operation in FM Mode	5-28
Displaying the RTTY Communication Screen	5-17	Adjusting Microphone Gain during Operation in FM Mode	5-28
Switching between the FFT Scope and X-Y Scope Display	5-17	Operation in Narrow FM Mode	5-29
Operating the RTTY Encode/Decode Screen	5-18	Operating the FM Repeater	5-29
Indicator Displays	5-18	Configuring the Tone Signal	5-29
		Selecting a Tone	5-29

Configuring the Tone Frequency	5-29
Tone Frequency Scan	5-29
CTCSS Operation	5-30
Selecting CTCSS	5-30
Configuring the CTCSS Frequency	5-30
CTCSS Frequency Scan	5-30
Cross Tone	5-30
Selecting Cross Tone	5-30
Configuring the TX/RX Tones	5-30

6 REJECTING INTERFERENCE

Attenuator	6-1
Switching the IF Filter Band Characteristics	6-1
Switching the RX Filter (A, B, C)	6-1
Configuring the Selectable Types of RX Filters	6-1
Filter Scope	6-1
RX Filter Screen	6-2
Displaying the RX Filter Screen	6-2
Selecting a Roofing Filter	6-2
Switching the IF Filter Shape	6-2
Switching the AF Filter Type	6-2
Configuring the Behavior of the HI/SHIFT and LO/WIDTH Controls (SSB/SSB-DATA Only)	6-2
Changing the Cutoff Frequency	6-3
Changing the Passband Width and Shift Amount	6-3
Preset Passband Characteristics	6-4
Audio Peak Filter in the CW Mode	6-4
Turning ON/OFF Audio Peak Filter	6-4
Displaying the Audio Peak Filter Screen	6-4
Switching the Passband Characteristics	6-4
Shifting the Passband Width	6-4
Configuring the Peak Gain	6-4
Audio Peak Filter in the FSK Mode	6-5
Noise Blanker	6-5
Turning ON/OFF Noise Blanker 1/2	6-5
Adjusting the NB1 Level	6-5
NB2	6-6
Configuring the NB2 Effect Level (Type A)/ NB2 Pulse Sensitivity Level (Type B)	6-6
Configuring the Blanking Duration (Type B Only)	6-6
Configuring the NB2 Attenuation Level (Type B Only)	6-6
Notch Filter	6-6
Turning ON/OFF Notch Filter	6-6
Switching the Notch Filter Bandwidth	6-7
Noise Reduction	6-7
Turning ON/OFF Noise Reduction	6-7
Configuring the NR1 Effect Level	6-7
Configuring the NR2 Correlation Time	6-7
Beat Canceler	6-8
Turning ON/OFF Beat Canceler	6-8
DSP Monitor	6-8
Assigning DSP Monitor to PF Key	6-8
Expanding the Passband Width Using DSP Monitor	6-8

7 SCOPE FUNCTIONS

Bandscope	7-1
Displaying the Bandscope	7-1
Switching the Bandscope Display Type	7-1
Adjusting the Reference Level	7-1
Configuring the Speed of Waterfall Drop	7-1
Waterfall Display during Tuning (Center Mode)	7-2
Reduced Bandscope Display	7-2
Switching the Scope Display Mode	7-2
Switching the Display Frequency Span	7-2
Selecting Relative or Absolute Frequency Display for the Grid (Center Mode)	7-2

Marker Shift	7-2
Shifting the Marker	7-2
Changing the Shift Position of Marker Shift	7-3
Expand	7-3
Scope Range of Each Band (Fixed Mode)	7-3
Switching the Scope Range	7-3
Configuring the Scope Range	7-3
Marker Centering	7-4
Notification on Exceeding of Lower or Upper Limit	7-4
Displaying Tuning Assist Line (SSB Only)	7-4
Touchscreen Tuning	7-4
Turning ON/OFF Touchscreen Tuning	7-4
Configuring the Gradation of the Waterfall	7-4
Touchscreen Tuning Correction	7-5
Step Correction	7-5
Marker Display	7-5
Registering a Marker	7-5
Deleting a Registered Frequency	7-5
Turning ON/OFF Marker Function	7-5
Displaying the Maximum Value in the Waveform	7-5
Turning ON/OFF Maximum Value Display	7-5
Configuring the Hold Type	7-5
Pausing the Waveform Display	7-6
Averaging of Bandscope Waveform	7-6
Switching the Bandscope Attenuator	7-6
Displaying the TX Signal Waveform	7-6
Audio Scope	7-6
Displaying the Audio Scope	7-6
Switching the Audio Scope Display Type	7-6
Switching the Audio Scope Attenuator	7-7
Switching the Display Frequency Span of the Audio Scope	7-7
Switching the Oscilloscope Level	7-7
Switching the Sweep Time	7-7
Pausing the Audio Scope	7-7

8 TRANSMIT FUNCTIONS

Configuration of the Input Path of TX Audio	8-1
Switching the Audio Source Input	8-1
VOX (Voice-Operated Transmit)	8-1
Turning ON/OFF VOX Function	8-1
Selecting Audio Source Input for Data VOX	8-1
VOX Configuration Screen	8-2
Adjusting VOX Gain	8-2
Adjusting the Anti VOX Gain Level	8-2
Adjusting VOX Delay Time	8-2
VOX Voice Delay	8-2
TX Monitor	8-3
Adjusting the TX Monitor Level	8-3
Speech Processor	8-3
Turning ON/OFF Speech Processor	8-3
Speech Processor Configuration Screen	8-3
Configuring the Speech Processor Input Level	8-4
Configuring the Speech Processor Output Level	8-4
Configuring the Speech Processor Effect	8-4
TX Filter	8-4
Displaying the Filter Scope during Transmission	8-4
Changing the TX Filter Bandwidth	8-5
Configuring the Low Cutoff Frequency in the SSB/AM Mode	8-5
Configuring the High Cutoff Frequency in the SSB/AM Mode	8-5
Configuring the Low Cutoff Frequency in the SSB-DATA/AM-DATA Mode	8-5
Configuring the High Cutoff Frequency in the SSB-DATA/AM-DATA Mode	8-5
TX Equalizer	8-5
Turning ON/OFF TX Equalizer	8-5
Selecting a Frequency Characteristic for the TX Equalizer	8-5

CONTENTS

Adjusting the TX Equalizer	8-6	Registering a Name for a Voice Message	12-1
Copying the TX Equalizer Settings	8-6	Playing Back a Voice Message	12-2
Saving the TX Equalizer Settings	8-6	Adjusting the Playback Volume	12-2
Reading the TX Equalizer Settings	8-7	Sending a Voice Message	12-2
TX Tuning	8-7	Deleting a Voice Message	12-2
Adjusting TX Output Power during TX Tuning	8-7	Configuring the Time Interval for Repeated Transmission	12-2
Timeout Timer (TOT)	8-8	Recording/Playing Voice Communication	12-3
ID Beep	8-8	Manual Recording	12-3
9 MEMORY CHANNELS		Full-time Recording	12-3
Displaying the Memory Channel List	9-1	Configuring the Maximum Duration for Full-time Recording	12-3
Registering Operating Frequency Data to a Memory Channel	9-2	Saving Full-time Recording Audio	12-3
Configuring the Operating Data through Direct Frequency Entry	9-2	Audio Recording in Tandem with Squelch	12-3
Memory Channel Mode	9-2	Quick Playback	12-4
Operating in the Memory Channel Mode	9-2	Adjusting the Playback Volume	12-4
Direct Entry of a Memory Channel Number	9-2	Audio Recording File Screen	12-4
Changing the Memory Channel Temporarily	9-3	Playing Back an Audio File	12-4
Changing the Frequency Temporarily	9-3	Renaming an Audio File	12-5
Copying the Operating Data of a Memory Channel	9-3	Deleting an Audio File	12-5
Memory Shift (Memory → VFO)	9-3	13 VOICE GUIDANCE	
Selecting a Memory Channel and Copying to VFO	9-3	Voice Guidance	13-1
Copying Data from the Memory Channel List Screen to VFO	9-3	Adjusting the Voice Guidance Volume	13-1
Channel-to-Channel Copying	9-3	Adjusting the Voice Guidance Speed	13-1
Configuring the Program Scan Frequency Range	9-4	Configuring the Voice Guidance Language	13-1
Erasing Memory Channels	9-4	Auto Voice Guidance	13-1
Registering a Memory Channel Name	9-4	Voice 1	13-2
Quick Memory Channels	9-5	Voice 2	13-12
Registering a Quick Memory Channel	9-5	Voice 3	13-12
Calling up a Quick Memory Channel	9-5	14 CLOCK DISPLAY/TIMER	
Configuring the Number of Quick Memory Channels	9-5	Configuring Date and Time	14-1
Erasing a Quick Memory Channel	9-5	Displaying the Clock Menu Screen	14-1
Memory Shift (Quick Memory → VFO)	9-6	Configuring the Local Clock Date	14-1
10 SCAN		Configuring the Local Clock Time	14-1
Program Scan	10-1	Configuring the Local Clock Time Zone	14-1
Starting the Program Scan (VFO Scan)	10-1	Configuring the Auxiliary Clock Time Zone	14-1
Configuring the Program Scan (VFO Scan) Frequency Range	10-1	Registering an Auxiliary Clock Identifier	14-1
Switching the Scan Speed	10-2	Configuring the Date Display Format	14-2
Program Slow Scan	10-2	Configuring the Clock Display	14-2
Turning ON/OFF Program Slow Scan	10-2	Clock Correction Using NTP (Network Time Protocol)	14-2
Configuring the Frequency Points for Program Slow Scan	10-2	Displaying the Auto Correction Configuration Screen	14-2
Configuring the Segment for Program Slow Scan	10-3	Configuring the NTP Server Address	14-2
Scan Hold	10-3	Turning ON/OFF Auto Clock Correction	14-3
Memory Scan	10-3	Correcting the Date and Time Manually	14-3
Performing Memory Scan	10-3	Timer	14-3
Configuring All-channel Scan and Group Scan	10-3	Configuring the Program Timer	14-3
Memory Channel Lockout	10-4	Pausing Program Timer Operation	14-4
Quick Memory Scan	10-4	Sleep timer	14-5
Configuring the Conditions for Resuming Scan	10-4	Configuring the Sleep Timer	14-5
11 USB/FILE MANAGEMENT		Pausing the Sleep Timer	14-5
Managing Different File Types	11-1	APO (Automatic Power Off)	14-5
USB/File Management Menu Screen	11-2	15 NETWORK/KNS OPERATION	
Configuring the Destination for Saving Files	11-2	LAN	15-1
Saving Settings Data	11-2	Configuring the IP Address	15-1
Reading Settings Data	11-3	Viewing the MAC Address	15-2
Changing the Name of Files Stored in the Built-in Memory	11-4	KNS Operation	15-2
Copying Files to a PC	11-4	Configuring for KNS Operation	15-3
Deleting Files (Built-in Memory)	11-5	LAN Connection Settings	15-3
Formatting a USB Flash Drive	11-5	Administrator Settings	15-3
Copying Files to a USB Flash Drive	11-5	Built-in VoIP Function	15-4
Safely Removing the USB Flash Drive	11-6	Audio Input/Output Level of Built-in VoIP	15-4
12 VOICE MESSAGE/AUDIO FILE		Built-in VoIP Jitter Absorption Buffer	15-4
Recording/Playing a Voice Message	12-1	Prohibition of Remote Volume Control	15-4
Recording a Voice Message	12-1	KNS Communication Log	15-4



1 INSTALLATION AND CONNECTION

Installation

- ! Do not lift this transceiver by holding the Tuning control or other control knobs on the front panel or the connectors on the rear panel. Doing so may result in injury or damage of the control knobs.

Antenna Installation and Connection

The antenna system is made up of the antenna, coaxial cables and a ground terminal. Installing the antenna system carefully and properly helps to optimize the performance of the transceiver.

- Make use of a correctly-adjusted 50 Ω antenna, 50 Ω coaxial cables and appropriate connectors. Make sure that all connections are cleaned and free of dirt before fastening them.
- Match the impedance of the coaxial cable and antenna such that SWR is 1:1.5 or lower.
- A high SWR may lower the TX output power, thereby causing radio interference with electrical appliances such as radio and TV as well as failure of this transceiver.
- If reports on signal distortion are received, this means the transceiver may not be transmitting efficiently.

- !
 - Transmitting without connecting the antenna may damage this transceiver. Before transmission, connect an antenna or a 50 Ω dummy load to this transceiver.
 - The protection circuit of this transceiver will be activated if the SWR of the antenna exceeds 1.5. Use an antenna with a low SWR.
 - When an RX antenna that makes use of semiconductors (such as an active antenna) is connected, transmission or antenna tuning must not be performed. Doing so supplies power to the antenna and may damage the semiconductor circuit of the antenna.

Ground Connection

Connect to the ground terminal correctly to avoid risks such as electric shock.

First of all, bury one or multiple ground bars or a large copper sheet in the ground and connect them to the GND terminal of this transceiver. Use a thick conducting wire or a cut copper band that is as short as possible for this connection.

- !
 - Gas pipes, conduit pipes for power distribution, plastic water pipes and the like must not be used for grounding. Not only are they ineffective for grounding, they may also result in accidents or fire.

Installation of Lightning Arrestors

- To prevent fire, electric shock, malfunctioning and injury due to lightning, install a coaxial lightning arrester.
- Besides installing a coaxial lightning arrester, disconnect the cable of the antenna from this transceiver if lightning is anticipated.

Connection of Regulated DC Power Supply

- !
 - Make sure to turn off the power of the regulated DC power supply before connecting the DC power cord.
 - Do not insert the power plug of the regulated DC power supply into the AC outlet until all the connections are complete.

A DC 13.8 V regulated DC power supply is needed for using this transceiver. It cannot be connected directly to an AC outlet. Use the supplied DC power cord to connect this transceiver to the regulated DC power supply.

- The current capacity needed for the regulated DC power supply is 22.5 A and above. Use one with sufficient current capacity.

1 Connect the DC power cord to the regulated DC power supply.

Connect the red wire to the “+” terminal and the black wire to the “-” terminal.

2 Next, connect the DC power cord to the DC 13.8 V power connector of this transceiver.

Insert the cord fully into the power connector.

Using the Auxiliary Support

An auxiliary support is stored inside the front leg of this transceiver. Pull it toward you if you want the panel to face slightly upwards.

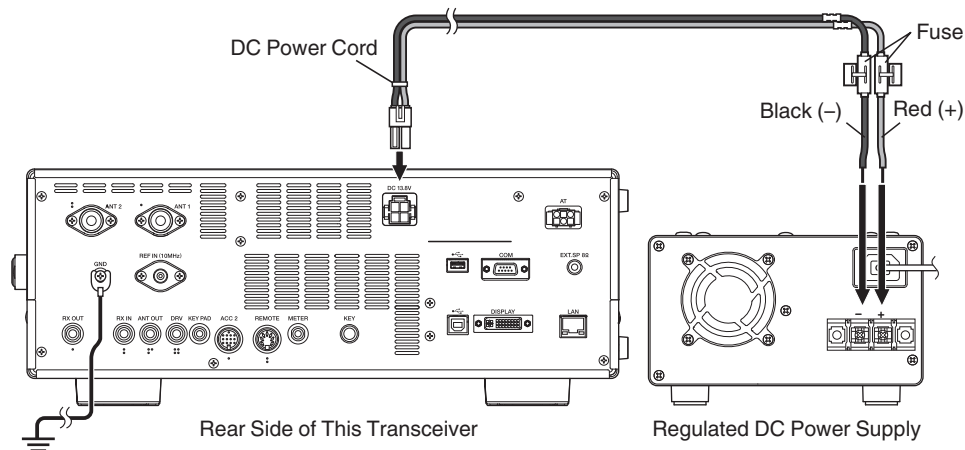
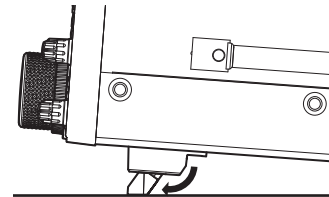

1 INSTALLATION AND CONNECTION

Torque Adjustment with Tuning Control

The Tuning control allows the rotational torque (weight) to be adjusted according to the user's preference. With the ring at the base of the Tuning control fixed, turning the Tuning control to the right increases the rotational torque, while turning to the left decreases it.

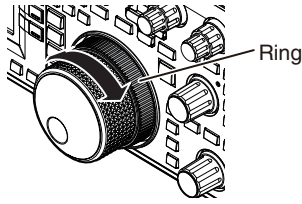

Paddle (PADDLE)

For CW operation using the built-in electronic keyer, connect a keyer paddle to the PADDLE jack. A $\Phi 6.3$ mm three-pronged plug is used for the paddle. Also, a straight key can be connected to the PADDLE jack. In this case, change the setting of Menu [5-00] to "Straight Key". (Refer to Chapter 3 for details on menu operation.)

USB Flash Drive/USB Keyboard (USB-A)

For connecting a commercially available USB flash drive or USB keyboard. Plug the USB flash drive or USB keyboard firmly into the (USB-A) connector.

- Do not remove the USB flash drive while reading or writing files or while the USB flash drive is being accessed by this transceiver. Also, do not turn off the power of this transceiver.
- Always remove the USB flash drive after ensuring that this can be done safely to prevent data in the USB flash drive from being damaged. (USB/File Management Menu "Safe Removal of USB Flash Drive")
- A USB flash drive or USB keyboard can be connected to the connector on the front panel and rear panel respectively.

Connection of Accessories (Front Panel)

Headphones (PHONES)

Monaural and stereo headphones (4 to 32 Ω , standard: 8 Ω /plug: $\Phi 6.3$ mm) can be used with this transceiver. When headphones are connected, sound will not be output from the built-in speakers (or optional external speakers). The following optional headphones are compatible with this transceiver.

- HS-5 ●HS-6

- The volume may be louder for headphones with a higher impedance.
- The audio output is monaural even when stereo headphones are connected.

Microphone (MIC)

Microphones with an impedance of 250 Ω to 600 Ω can be used. Insert the microphone plug fully into the MIC connector of this transceiver and tighten it firmly using the fastening ring. The following microphones (sold separately) are compatible with this transceiver.

- MC-43S ●MC-60A ●MC-90 ●MC-47

The following microphones are not compatible with this transceiver.

- MC-44 ●MC-44DM ●MC-45 ●MC-45DM

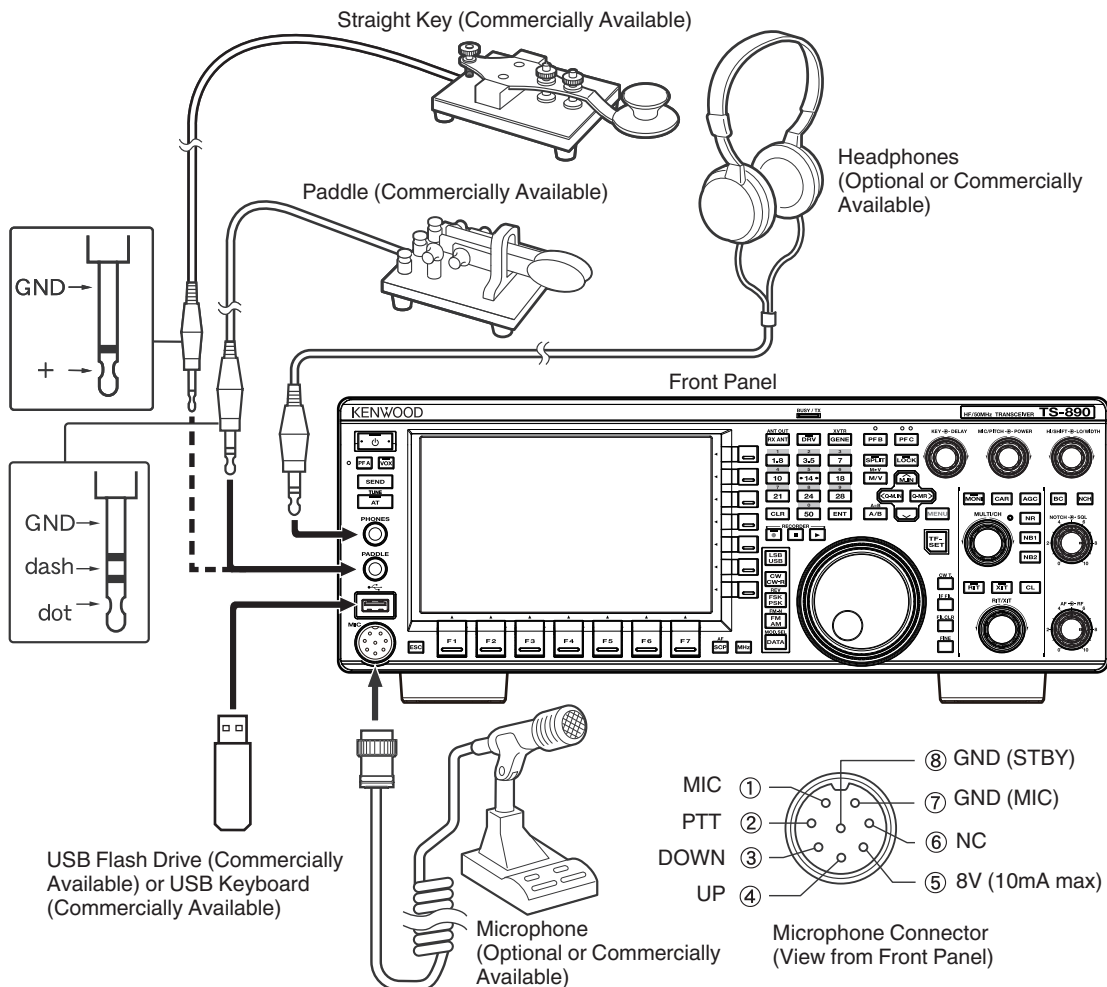

Connection of Accessories (Rear Panel)

- ✎ • A cable exceeding 3 m (9.8 feet) may not be connected to a connector below.
 - KEY jack
 - ACC 2 connector
 - REMOTE connector
 - METER jack
 - DRV connector
 - KEYPAD jack
 - COM connector
 - EXT.SP jack
 - DISPLAY connector
 - LAN connector
 - PHONES jack
 - PADDLE jack
 - MIC connector

Key for CW (KEY)

For CW operation without using the built-in electronic keyer, connect the plug of an electronic key, bug key, external electronic keyer or PC keyer to the KEY jack. Use a $\Phi 3.5$ mm two-pronged plug. Positive keying needs to be used for external electronic keyers and PC keyers. Use a shielded cable to connect the key and this transceiver.

- ✎ • For more detailed explanation on the built-in keyer, refer to "Electronic Keyer". (5-13)

USB Flash Drive/USB Keyboard ()

For connecting a commercially available USB flash drive or USB keyboard. Plug the USB flash drive or USB keyboard firmly into the (USB-A) connector.

- ✎ • A USB flash drive or USB keyboard can be connected to the connector on the front panel and rear panel respectively.

Keypad (KEYPAD)

For connecting a self-made PF keypad.

External Speaker (EXT. SP 8 Ω)

For connecting an external speaker.

- ! • The EXT. SP 8 Ω is used exclusively for connecting an external speaker. Due to the loud audio output, hearing may be impaired when headphones are used. Do not connect headphones.

External Display (DISPLAY)

Connect this transceiver with an external display using a commercially available DVI cable.

Doing so enables information displayed on the screen of this transceiver to be shown on the external display.

- ✎ • Use an external display with a resolution of 800 x 600 or 848 x 480.
- This transceiver supports digital and analog outputs.
- If the display to connect uses a D-sub terminal, make use of a commercially available DVI/D-Sub conversion adapter.

External Meter (METER)

For connecting a commercially available meter.

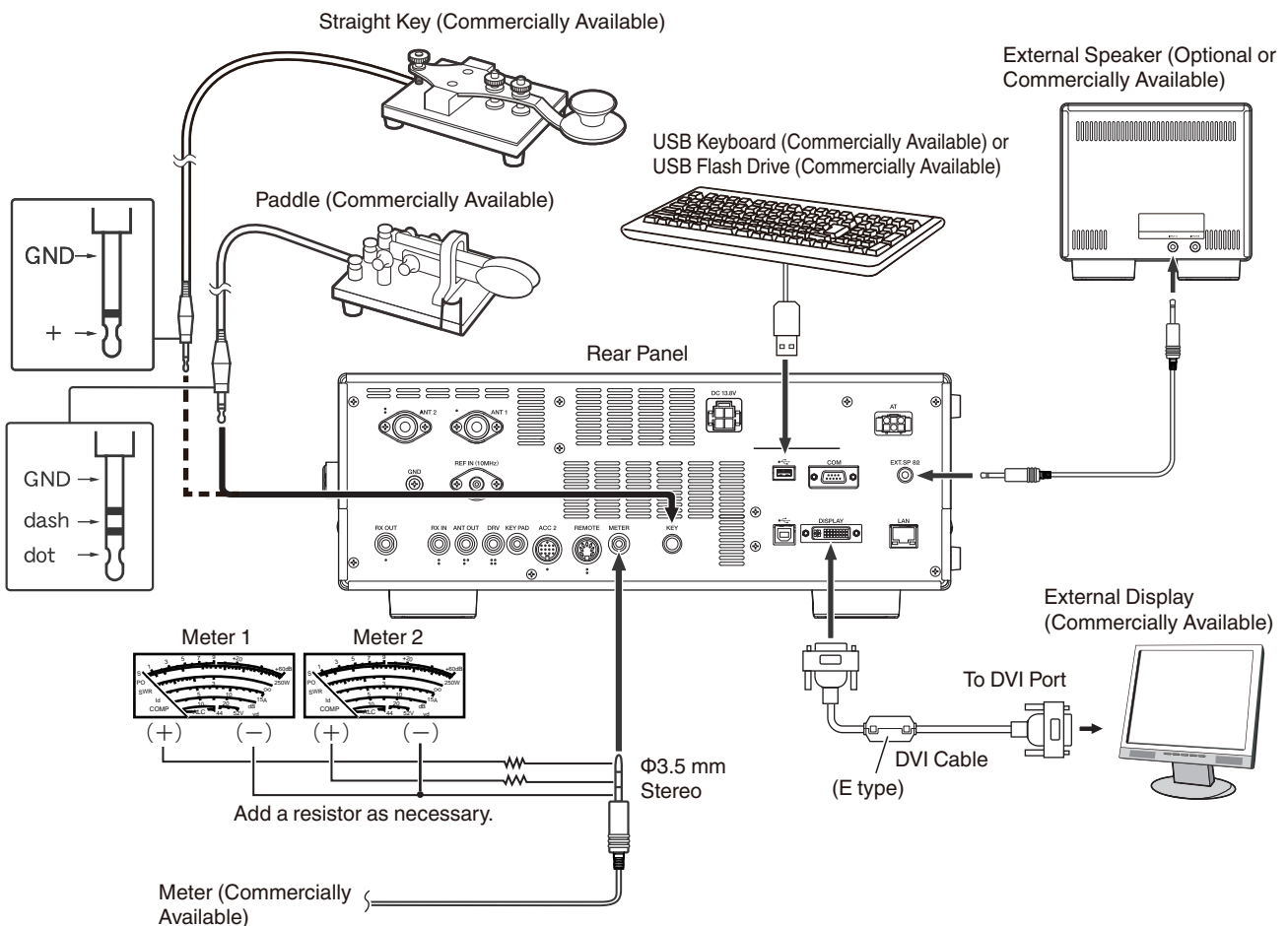

1 INSTALLATION AND CONNECTION

Connection with Data Communication Equipment

PC Connection

This transceiver is equipped with connectors (ACC 2 and USB) for exchanging audio signals with the supplied equipment for data communication using an external device. These connectors are collectively referred to as data communication connectors in this manual. To make use of data communication such as RTTY (AFSK), PSK31, SSTV, JT65 and FT8 using data communication software that employs the sound function of a PC and with this transceiver configured to the DATA mode (SSB-DATA, FM-DATA, AM-DATA), set up the connection as follows.

- When using the USB audio function: connect to the USB port of the PC. Data communication with only the USB cable connection is possible by making use of data VOX or PC commands ("TX1;" to start transmission and "RX;" to end transmission) to switch between transmission and reception. (For details on the configuration of the input sound source in the DATA mode and the VOX function, refer to page 8-1.) Before connecting this transceiver with a PC using a USB cable, download also a virtual COM port driver and install it on the PC.

http://www.kenwood.com/i/products/info/amateur/software_download.html

- When using an ACC 2 connector: connect the audio output line of the PC to pin 11 (ANI) of the ACC 2 connector and the audio input line of the PC to pin 3 (ANO). Pin 9 (PKS) of the ACC 2 connector, data VOX or PC commands ("TX1;" to start transmission and "RX;" to end transmission) are used to switch between transmission and reception. When using PC commands, connect the transceiver and the PC with a RS-232C straight cable or a USB cable.

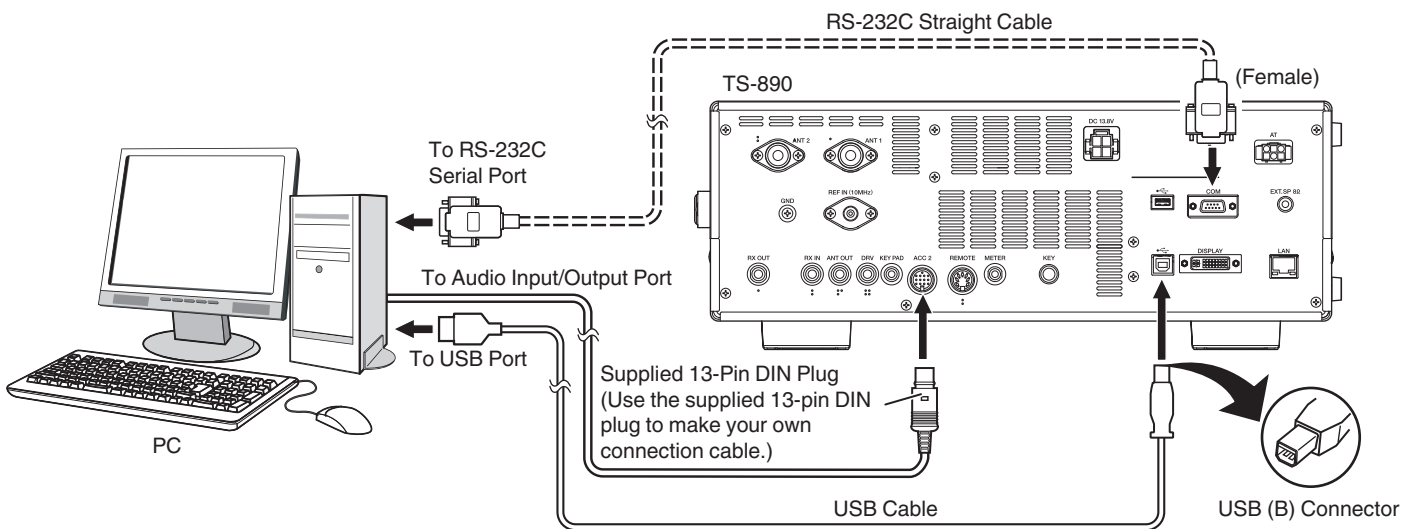

TNC Connection

For packet communication and the like using an external TNC (terminal node controller) with this transceiver configured to DATA mode, make use of the ACC 2 connector. Connect the modulation output line, demodulation input line and TX control (PTT) of the external TNC to pin 11 (ANI), pin 3 (ANO) and to pin 13 (PKS) of the ACC 2 connector respectively. (For details on the configuration of the input sound source in the DATA mode, refer to page 8-1.)

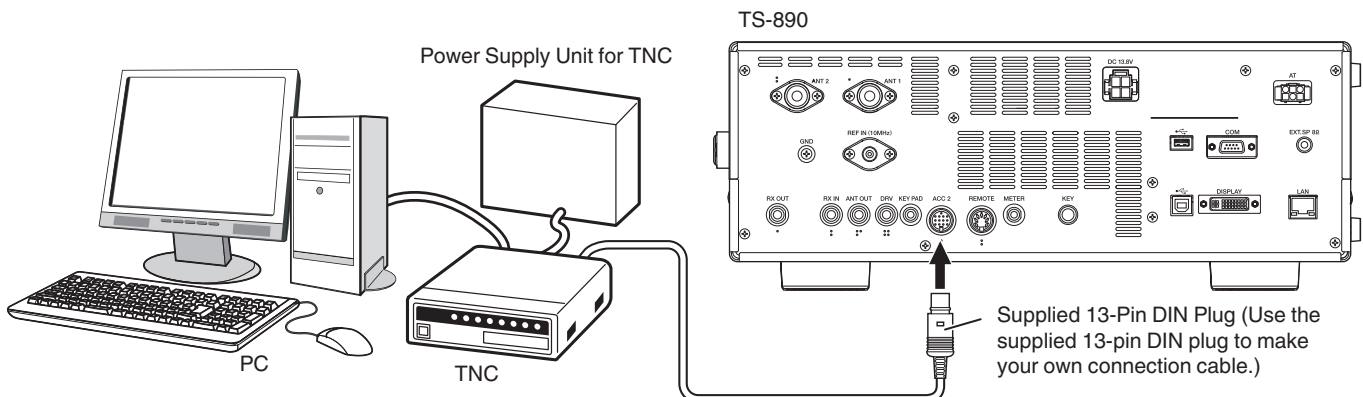

- USB cable and RS-232C straight cable are not supplied with this transceiver. Please purchase commercially available cables.
- Delays may occur when using USB audio, and there may also be audio interruptions depending on the performance and load of the PC.
- Place this transceiver far enough from the PC and TNC so that noise will not be picked up.
- For data communication software settings, refer to the instruction manual or Help file of the software in use.

Terminal Descriptions

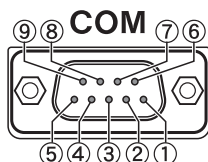

COM Connector

Pin No.	Pin Name	Function	Input/Output
1	NC	No connection	—
2	RXD	Sends serial data to PC.	O
3	TXD	Receives serial data from PC.	I
4	NC	No connection	—
5	GND	Signal ground	—
6	NC	No connection	—
7	RTS	Sends signal from the PC to this transceiver. If the PC is unable to accept incoming data, an “L” level signal is output from the PC to this transceiver and data will not be sent in this case.	I
8	CTS	Sends signal from this transceiver to the PC. If this transceiver is unable to accept incoming data, an “L” level signal is output from this transceiver to the PC and input of incoming data will be forbidden.	O
9	NC	No connection	—

REMOTE

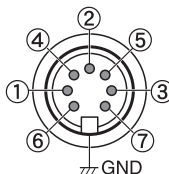

GND :
Connect to metal shield.

REMOTE Connector

Pin No.	Pin Name	Function	Input/Output
1	SPO	Speaker out	O
2	COM	Common terminal of the built-in relay for linear amplifier control	I/O
3	SS	PTT input Sends signal by grounding the SS terminal.	I
4	MKE	Make terminal of the built-in relay for linear amplifier control • The make terminal can be connected to the common terminal during transmission by configuring “Internal Relay Control” of the linear amplifier menu. Rated control capacity of relay contact: 2 A/ 30 V DC (resistance load) Maximum allowable voltage of relay contact: 220 V DC, 250 V AC	I/O
5	BRK	Break terminal of the built-in relay for linear amplifier control The break terminal can be connected with the common terminal when the latter is not connected to a make terminal. Rated control capacity of relay contact: 2 A/ 30 V DC (resistance load) Maximum allowable voltage of relay contact: 220 V DC, 250 V AC	I/O
6	ALC	ALC input from the linear amplifier	I
7	LKY	Linear amplifier control output • The output logic during transmission can be configured using “Keying Logic” of the linear amplifier menu. “Active High”: Outputs DC 12 V during transmission. The maximum output current is 100 mA. “Active Low”: Switches to the “L” level (GND and short) during transmission. When an external bias is applied while receiving is in progress, the signal switches to the “H” level. Voltage and current not higher than DC 50 V and 100 mA respectively can be controlled.	O

1 INSTALLATION AND CONNECTION

ACC 2

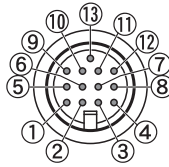

ACC 2 Connector

Pin No.	Pin Name	Function	Input/Output
—	NC	No connection	—
2	RTTY	RTTY control terminal (FSK key input)	I
3	ANO	Audio output <ul style="list-style-type: none"> Connect to the audio input of the TNC, MCP or PC (or PC connection interface). The audio output level is independent of the AF volume control knob on the front panel. The audio output level can be adjusted in Menu [7-09]. Adjust it to an appropriate level. When the audio output level is configured to the default value of “50” in Menu [7-09], the peak-to-peak voltage is approximately 0.5 V p-p in the case of standard modulation signals. Altering the audio output level between “0” and “100” changes the peak-to-peak voltage level between approximately 0 Vp-p and 1.2 Vp-p. (Impedance 10 kΩ) 	O
4	GND	Signal ground	—
5	PSQ	Squelch control output <ul style="list-style-type: none"> Connect to the squelch input of the TNC, MCP or PC connection interface. When squelch is open: Low impedance When squelch is closed: High impedance 	O
6	MET 1	Meter level output 1	O
7	NC	No connection	—
8	GND	Signal ground	—
9	PKS	PTT input for data communication (DATA SEND) <ul style="list-style-type: none"> Connect to the PTT output of the TNC, MCP or PC connection interface. Signal can be transmitted by connecting the PKS terminal to GND. The PKS terminal mutes unnecessary modulation input signals during transmission. “Configuration of the Input Path of TX Audio” 	I
10	MET2	Meter level output 2	O
11	ANI	Audio input for data communication <ul style="list-style-type: none"> Connect to the audio output of the TNC, MCP or PC (or PC connection interface). The audio input level is independent of MIC GAIN on the front panel. The audio input level can be adjusted in Menu [7-07]. Standard modulation can be obtained with an input of approximately 10 mVrms in the default setting of “50” in Menu [7-09]. Altering the audio input level between “0” and “100” changes the standard modulation input level between approximately “almost no modulation” and approx. 1 mVrms. (Impedance 10 kΩ) 	I
12	GND	Signal ground	—
13	SS	PTT input <ul style="list-style-type: none"> This is the same terminal as pin 2 (SS terminal) of the MIC connector on the front panel and pin 3 (SS terminal) of the REMOTE connector. It has the same behavior as pressing [SEND] on the front panel. Signal can be transmitted by connecting the SS terminal to GND. The SS terminal mutes unnecessary modulation input signals during transmission. “Configuration of the Input Path of TX Audio” 	I

AT

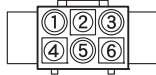

EXT. AT Connector

Pin No.	Pin Name	Function	Input/Output
1	GND	Signal ground	—
2	TT	EXT.AT connector (TTI/TTO)	I/O
3	GND	Signal ground	—
4	NC	No connection	—
5	TS	EXT.AT connector (TSI/TSO)	I/O
6	14S	DC 13.8 V power supply for EXT.AT	O

MIC

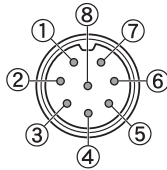

MIC Connector

Pin No.	Pin Name	Function	Input/Output
1	MIC	MIC signal input	I
2	SS	MIC standby (PTT) control	I
3	MD	MIC DOWN control	I
4	MU	MIC UP control	I
5	8 A	DC 8 V power supply for MIC	O
6	NC	No connection	—
7	MSG	MIC ground	—
8	MCG	Signal ground	—



2 NAMES AND FUNCTIONS OF PARTS

Front Panel

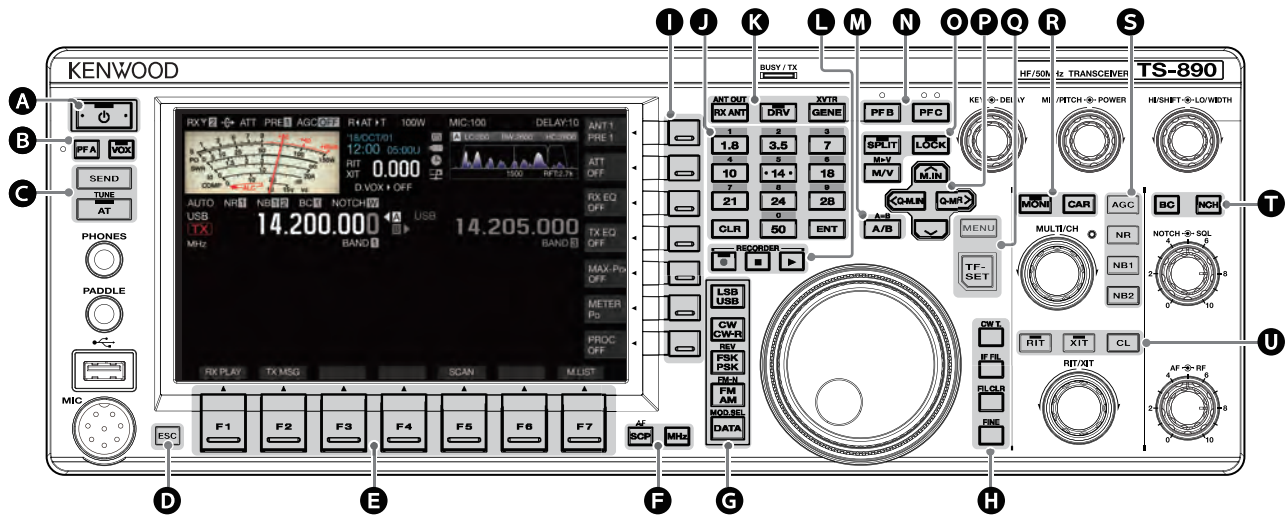



Panel Key Behavior

	Key	Behavior	Refer to	
A	[I/O]	Press	Turns on the power.	4-1
		Press and hold	Turns off the power.	
B	[PF A]	Press	Activates the registered function.	16-2
		Press and hold		
	[VOX]	Press	Turns ON/OFF the VOX function.	8-1
		Press and hold	Displays the VOX configuration screen.	8-2
C	[SEND]	Press	Starts/ends transmission.	4-7
	[AT]	Press	Turns ON/OFF the antenna tuner.	4-11
Press and hold		Starts antenna tuning.		
D	[ESC]	Press	Exits the configuration screen.	-
E	[F1] to [F7] (Horizontally Arrayed F)	Activates the function according to the key guide at the bottom of the screen. (Henceforth represented as F1 [XXX] to F7 [XXX] in this manual.) Refer to "List of Function Key Behaviors (Standard Mode Screen)" for functions of the F key on the normal screen.		2-4
F	[SCP]	Press	Displays the bandscope. Switches the scope screen.	7-1 7-6
		Press and hold	Displays the audio scope. Switches between bandscope and audio scope.	
	[MHz]	Press	Turns ON/OFF the MHz step function.	4-6
G	[LSB/USB]	Press	Switches between the LSB and USB modes.	4-4
	[CW/CW-R]	Press	Switches between the CW and CW-R modes.	4-4
	[FSK/PSK]	Press	Switches between the FSK and PSK modes.	4-4
		Press and hold	Switches between reverse and normal in the FSK/PSK mode.	
	[FM/AM]	Press	Switches between the FM and AM modes.	4-4
		Press and hold	Switches between FM narrow and FM normal.	
[DATA]	Press	Switches the DATA mode.	4-4	
	Press and hold	Displays the input source configuration screen for the TX audio.	8-1	

2 NAMES AND FUNCTIONS OF PARTS

	Key		Behavior	Refer to
H	[CW T.]	Press	Activates the CW auto tune function.	5-9
	[IF FIL]	Press	Switches between receiver (RX) filters A, B and C.	6-1
		Press and hold	Displays the RX Filter screen.	6-2
	[FIL CLR]	Press	Restores the passband of the RX filter that has been changed to the preset value.	6-4
	[FINE]	Press	Turns ON/OFF the FINE-tuning function.	4-5
I	[] to [] (Vertically Arrayed F)		Activates the function according to the key guide on the right side of the screen. (Henceforth represented as F [XXX] in this manual.) Refer to "List of Function Key Behaviors (Standard Mode Screen)" for functions of the F key on the normal screen.	2-4
J	[0 (50)] to [9 (28)]	Press	For selecting a frequency band and switching band memory.	4-3
	[CLR]	Press	Cancels the direct frequency input mode.	-
	[ENT]	Press	Turns on the direct frequency input mode.	4-6
K	[RX ANT]	Press	Turns ON/OFF the RX antenna.	4-10
		Press and hold	Turns ON/OFF the antenna output function for the external receiver.	16-15
	[DRV]	Press	Turns ON/OFF the drive output function.	4-10
	[GENE]	Press	For selecting a general coverage band.	4-3
Press and hold		Turns ON/OFF the transverter function.	16-15	
L	[●]	Press	Starts, pauses or resumes manual recording.	12-3
		Press and hold	Saves the constantly recorded audio file.	12-3
	[■]	Press	Stops audio recording or playback.	12-4
	[▶]	Press	Starts, pauses or resumes playback.	
M	[A/B]	Press	Switches between VFO A and VFO B.	4-2
		Press and hold	Aligns the frequency and mode of VFO A and VFO B.	5-1
N	[PF B]	Press	Activates the registered function.	16-2
		Press and hold		
	[PF C]	Press	Activates the registered function.	16-2
		Press and hold		
O	[SPLIT]	Press	Turns ON/OFF the split mode.	5-1
		Press and hold	Starts configuration of the frequency for split operation.	5-1
	[LOCK]	Press	Turns ON/OFF the frequency lock function.	4-7
	[M/V]	Press	Switches between the memory channel and VFO mode.	9-2
Press and hold		Copies the memory channel data and quick memory channel data to VFO.	9-3	

	Key		Behavior	Refer to
P	[ M.IN]	Press	Displays the memory channel list screen.	9-1
			Registers a memory channel.	9-1
			Switches the menu mode item.	3-1
	[<Q-M.IN]	Press	Registers a quick memory channel.	9-5
			Switches the menu mode item.	3-1
[Q-MR>]	Press	Calls up a quick memory channel.	9-5	
	Press and hold	Deletes all quick memory channels.	9-5	
	[]	Press	Switches the menu mode item.	3-1
Q	[MENU]	Press	Turns ON/OFF the menu mode.	3-1
	[TF-SET]	Press	Turns ON/OFF TF-SET. (ON while it is being pressed.)	5-2
R	[MONI]	Press	Turns ON/OFF the TX monitor function.	8-3
		Press and hold	Displays the TX monitor level configuration screen.	8-3
	[CAR]	Press	Displays the carrier level configuration screen.	5-8
S	[AGC]	Press	Switches the AGC time constant [FAST, MID, SLOW].	5-2
		Press and hold	Displays the AGC configuration screen.	5-2
	[NR]	Press	Switches the mode of the noise reduction function [OFF/NR1/NR2].	6-7
		Press and hold	Displays the NR1 configuration screen. (When Noise Reduction 1 is ON) Displays the NR2 configuration screen. (When Noise Reduction 2 is ON)	6-7
	[NB1]	Press	Turns ON/OFF the Noise Blanker 1.	6-5
		Press and hold	Displays the NB1 configuration screen.	6-5
	[NB2]	Press	Turns ON/OFF the Noise Blanker 2.	6-5
Press and hold		Displays the NB2 configuration screen.	6-6	
T	[BC]	Press	Switches the mode of the beat canceler function [OFF/BC1/BC2].	6-8
	[NCH]	Press	Turns ON/OFF the notch filter.	6-6
		Press and hold	Switches the bandwidth of the notch filter [Normal, Middle, Wide].	6-7
U	[RIT]	Press	Turns ON/OFF the RIT function.	5-7
		Press and hold	Shifts the RX frequency via RIT.	5-7
	[XIT]	Press	Turns ON/OFF the XIT function.	5-7
		Press and hold	Shifts the TX frequency via XIT.	5-7
	[CL]	Press	Clears the RIT or RIT/XIT frequency.	5-7

2 NAMES AND FUNCTIONS OF PARTS

List of Function Key Behaviors (Standard Mode Screen)

Function Keys (Vertically Arrayed)

	Key Guide		Behavior	Refer to
F	[ANT/PRE]	Press	Switches the preamplifier. (OFF/ PRE 1/ PRE 2)	5-6
		Press and hold	Switches between "ANT 1" and "ANT 2".	4-10
	[ATT]	Press	Switches the attenuation level of the attenuator. (OFF/ 6 dB/ 12 dB/ 18 dB)	6-1
		Press and hold	Switches in the reverse order.	6-1
	[RX EQ]	Press	Turns ON/OFF the RX equalizer.	5-4
		Press and hold	Displays the RX equalizer configuration screen.	5-4
	[TX EQ]	Press	Turns ON/OFF the TX equalizer.	8-5
		Press and hold	Displays the TX equalizer configuration screen.	8-5
	[MAX-Po]	Press	Turns ON/OFF the TX output power limiter.	4-8
		Press and hold	Displays the TX output power limiter configuration screen.	4-8
	[METER]	Press	Switches the meter display.	4-8
	[PROC]	Press	Turns ON/OFF the speech processor.	8-3
		Press and hold	Displays the Speech Processor configuration screen.	8-3

Function Keys (Horizontally Arrayed)

	Key Guide		Behavior	Refer to
F1	[RX PLAY]	Press	Displays the audio recording file screen.	12-4
F2	[TX MSG]	Press	Displays the voice message screen. (Displayed in the SSB, AM and FM modes.)	12-1
	[KEYER]	Press	Displays the CW message screen. (Displayed in the CW mode.)	5-14
F3	[DECODE]	Press	Displays the communication screen. (Displayed in the CW, FSK and PSK modes.)	5-10 5-22 5-22
F4	[TONE]	Press	Switches in the sequence of: "TONE" → "CTCSS" → "CROSS TONE". (Displayed in the FM mode.)	5-28
		Press and hold	Displays the TONE frequency, CTCSS frequency or cross tone configuration screen.	5-30 5-30
F5	[SCAN]	Press	Starts/stops scanning.	10-1 10-3
		Press and hold	Displays the VFO/Program Scan segment screen. (Displayed in the VFO mode.) Displays the memory scan group screen. (Displayed in the memory channel mode.)	10-1 10-3
F6	[M ► VFO]	Press	Shifts the memory. (Displayed in the memory channel and quick memory channel modes.)	9-3 9-6
F7	[M.LIST]	Press	Displays the memory channel list.	9-1

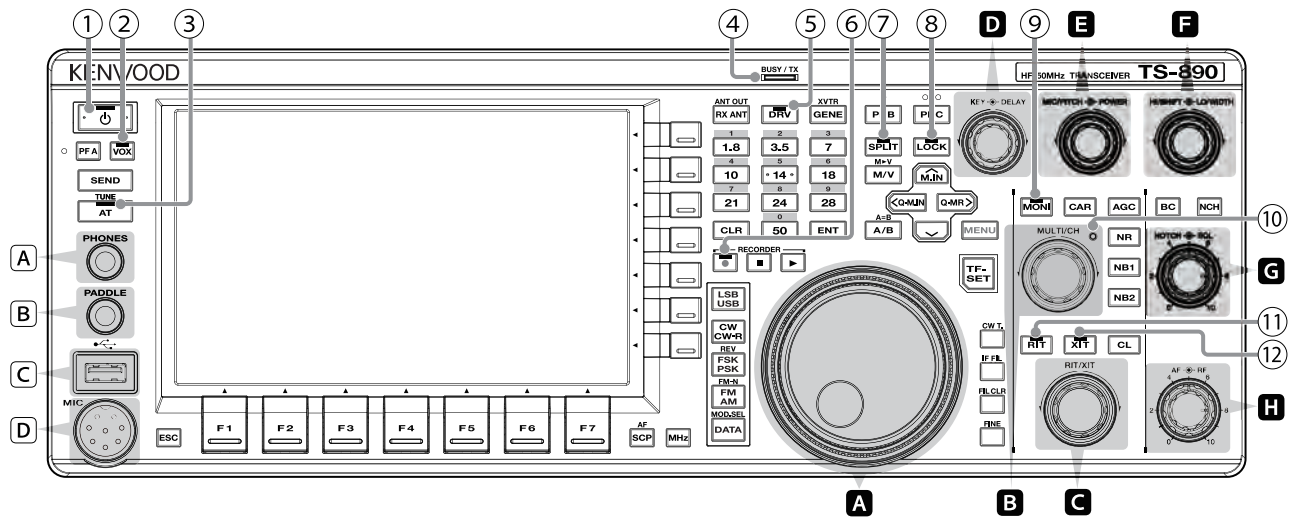

List of Control Knob Behaviors

Control	Behavior	Refer to
A Tuning	Aligns the TX and RX frequencies.	4-5
B [MULTI/CH]	Switches the frequency at a fast speed. (Available in the VFO mode.)	4-5
	Switches the channel number. (Available in the memory channel and quick memory channel modes.)	9-2
	Switches the item to configure or configured value. (Available when a configuration screen is displayed.)	3-1
C [RIT/XIT]	Changes the RIT/XIT frequency.	5-7
D [KEY] [DELAY]	Adjusts the keying speed.	5-13
	Adjusts the break-in delay time. (When the TX mode is configured to CW.)	5-8
E [MIC/PITCH] [POWER]	Adjusts the VOX delay time. (When the TX mode is configured to SSB, FM or AM.)	8-2
	Adjusts the microphone gain. (When the TX mode is configured to SSB or AM.)	4-7
	Adjusts the sidetone/pitch frequency. (When the TX mode is configured to CW.)	5-9
F [HI/SHIFT] [LO/WIDTH]	Adjusts the speech processor output level. (When the speech processor is ON.)	8-3
	Changes the TX output power level.	4-7
F [HI/SHIFT] [LO/WIDTH]	Changes the RX filter (high-cut frequency or shift frequency).	6-3
	Changes the RX filter (low-cut frequency or width frequency).	6-3
G [NOTCH] [SQL]	Adjusts the notch frequency.	6-6
	Adjusts the squelch level.	4-2
H [AF] [RF]	Adjusts the receiving volume.	4-2
	Adjusts the RF gain.	4-2

2 NAMES AND FUNCTIONS OF PARTS

List of LED Behaviors

	LED	Behavior
①	[POWER]	When power is OFF: light off
		When power is ON: lights up in green
		When power is OFF with timer activated: lights up in orange
		When timer is starting up: blinks in orange
②	[VOX]	Lights up when the VOX function is enabled.
③	[AT]	Lights up when the antenna tuner is ON.
		Blinks during antenna tuning.
④	[BUSY/TX]	Lights up in green when squelch opens upon receiving a signal.
		Lights up in red when transmission is in progress.
⑤	[DRV]	Lights up when drive output is ON.
⑥	[REC]	Lights up during manual recording (including when recording is paused). Blinks for 1 second at the start of saving the constantly recorded audio.
⑦	[SPLIT]	Lights up in the split mode.
		Blinks during configuration of the split frequency.
⑧	[LOCK]	Lights up when the frequency lock function is enabled.
⑨	[MONI]	Lights up when the TX monitor function is enabled.
⑩	[MULTI/CH]	Lights up when a configuration screen is displayed (when adjustments can be made using the [MULTI/CH] control).
⑪	[RIT]	Lights up when the RIT function is enabled.
⑫	[XIT]	Lights up when the XIT function is enabled.

Connectors and Jacks

	Name	Description
A	<PHONES> Jack	Jack for connecting to headphones.
B	<PADDLE> Jack	Jack for connecting a paddle while running in the CW mode.
C	<USB-A> Connector	Connector for connecting a USB flash drive or USB keyboard.
D	<MIC> Connector	Connector for connecting a microphone.

Rear Panel

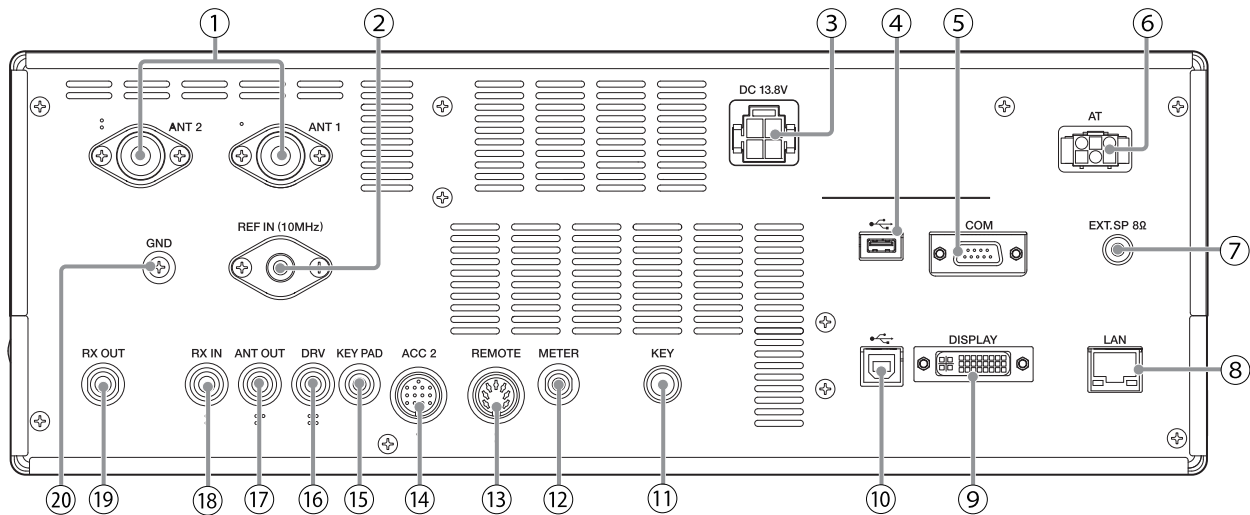

Connectors and Jacks on the Rear Panel

No.	Name	Description	Remarks
①	<ANT 1> Connector <ANT 2> Connector	M-type coaxial connector for connecting the antenna.	
②	<REF IN (10MHz)> Connector	For input of 10 MHz signals when using an external reference frequency.	<ul style="list-style-type: none"> • Input impedance: 50 Ω • Input: 0 dBm ±10 dB
③	<DC13.8V> Connector	For connecting a regulated DC power supply.	
④	<USB-A> Connector	Connector for connecting a USB flash drive or USB keyboard.	
⑤	<COM> Connector	RS-232C connector for connecting a PC or external device.	
⑥	<AT> Connector	Connector for controlling an external amplifier tuner.	
⑦	<EXT.SP> Jack	For connecting an external speaker.	
⑧	<LAN> Connector	Connector for connecting a PC or LAN when running with the KNS (KENWOOD NETWORK COMMAND SYSTEM) or for automatic correction of the clock time.	
⑨	<DISPLAY> Connector	DVI-I connector for connecting an external monitor. Both analog and digital signals can be output.	
⑩	<USB-B> Connector	Connector for connecting a PC. It is used to control this transceiver using the ARCP-890 as well as to input and output signals for transmission and reception via the digital communication application of a PC. It can be switched between transmission and reception by changing the menu setting and keying.	
⑪	<KEY> Jack	For connecting an electronic key (straight key, bug key, external electronic key, etc.) when running in the CW mode. This can be configured to a jack for paddle connection in the menu.	
⑫	<METER> Terminal	For connecting a commercially available meter.	<ul style="list-style-type: none"> • Output impedance: 4.7 Ω • Allowable open-end voltage output: 0 to 5 V
⑬	<REMOTE> Connector	For connecting a linear amplifier. (Use the supplied 7-pin DIN plug for the connection.)	
⑭	<ACC 2> Connector	For connecting an external device such as an external terminal. (Use the supplied 13-pin DIN plug for the connection.)	
⑮	<KEYPAD> Jack	For connecting a self-made PF keypad.	
⑯	<DRV> Connector	For connecting a transverter or linear amplifier.	<ul style="list-style-type: none"> • Output impedance: 50 Ω • Output: Approx. 1 mW (0 dBm)
⑰	<ANT OUT> Connector	For connecting devices such as an external receiver.	
⑱	<RX IN> Connector	For connecting an RX antenna, external bandpass filter, transverter and the like.	
⑲	<RX OUT> Connector	For connecting an external bandpass filter and the like.	
⑳	<GND> Terminal	For connecting a ground wire.	

2 NAMES AND FUNCTIONS OF PARTS

Microphone (Optional)

① PTT (Push-to-talk) Switch

Switches to the transmitting state while this switch is being pressed. Releasing the switch restores the transceiver to the receiving state.

② UP/ DOWN Keys

For scrolling up/down the items in one of the following modes, such as scrolling up/down the VFO frequencies. Pressing and holding down the key enables continuous scrolling. It can also be configured for use as a PF key.

- VFO mode: Scrolls up/down the VFO frequencies
- Memory channel mode: Scrolls up/down the memory channel numbers
- Memory scroll mode: Scrolls up/down the memory scroll numbers
- Mic paddle mode: For paddle (dot/dash) input
- Menu mode: Displays the previous or next option

③ LOCK Key (MC-60A/ MC-90 only)

Pressing this key activates the key lock and switches to the transmitting state. Pressing it again restores the key to the original position and switches to the receiving state.

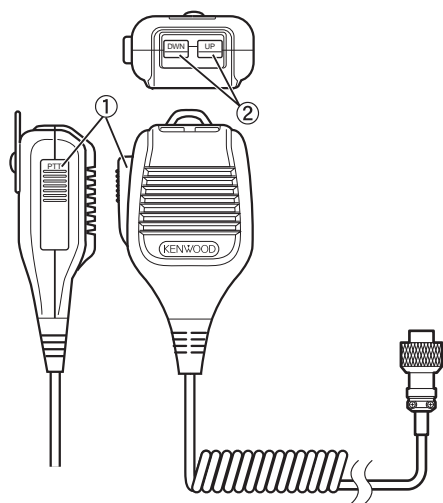

MC-43S

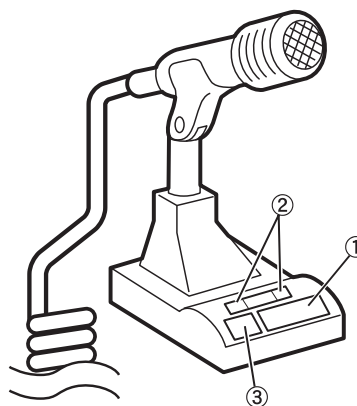







MC-60A/MC-90



















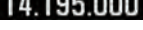

Screen



Area	Display	Description	Refer to
A	RX	Appears when an RX antenna is functioning.	4-10
	Y1	Displays the antenna number. Switches the antenna number accordingly when the antenna is switched. It is not displayed when the TX output power destination of the transverter is drive output (DRV).	4-10
	↵	Appears when antenna output for the external receiver is functioning.	16-15
	ATT	Appears when the receiving attenuator is configured to “6 dB”, “12 dB” or “18 dB”.	6-1
	PRE1 PRE2	Appears when the receive preamplifier 1 is ON. Appears when the receive preamplifier 2 is ON.	5-6
	AGCOFF AGC-F AGC-M AGC-S	Appears when AGC is OFF. Appears when AGC is configured to “FAST”. Appears when AGC is configured to “MID”. Appears when AGC is configured to “SLOW”.	5-2
	TONE	Appears when Tone is ON.	5-29
	CT	Appears when CTCSS is ON.	5-30
	CROSS	Appears when Cross Tone is ON.	5-30
B	R<AT>T	Displays the antenna tuner function and operating status. << R >> lights up when the antenna tuner is ON during reception. << R<AT>T >> blinks while antenna tuning is in progress.	4-11
	XVTR	Appears when the transverter is ON.	16-15
	TX TUNE	Blinks while TX tuning is ON.	8-7
	100W	Displays the TX output power level. (Not displayed when the TX output power destination is drive output (DRV).) Displayed in yellow when the output power is limited by the TX output power limiter function.	4-7
	100%	Displays the drive output level. (Displayed when drive output is ON.)	4-10
	30WPM	Displays the keying speed. Turning the [KEY SPEED] control displays the keying speed (4 to 60 words/minute) in the TX output power area for 2 seconds.	5-13
	01/JAN/18 10:00 01:00U	Displays the date of the local clock. The date can be displayed in the UK, US or Japanese format. Displays the time (24-hour format). Left: Displays the time of the local clock. Right: Displays the time of the auxiliary clock (indicated by the character “U” at the end).	14-1 14-1

2 NAMES AND FUNCTIONS OF PARTS

Area	Display	Description	Refer to
C	RIT	Appears when the RIT function is enabled.	5-7
	XIT	Appears when the XIT function is enabled.	
	0.000	Displays the RIT or XIT frequency (between -9.999 and 9.999 kHz).	
	D.VOX▶OFF	Appears according to the input path of the TX audio selected by the data VOX function. OFF: Appears when sound is not input from all paths. ACC 2: Appears when ACC 2 is used as the audio source input. USB: Appears when USB AUDIO is used as the audio source input. LAN: Appears when LAN is used as the audio source input.	8-1
D	MIC:100 PROC OUT:50	Displays the microphone gain. (Displayed when the speech processor is OFF) Displays the speech processor output level. (Displayed when the speech processor is ON)	4-7 8-4
	DELAY:10 FULL-BK	Displays the VOX delay time when the transmitting end is in the SSB, AM or FM mode. Displays the break-in delay time when the transmitting end is in the CW mode. “FULL-BK” is displayed during full break-in.	5-8
E		This is an icon of the internal memory. The icon is displayed in red when the remaining space is running low.	11-1
		The icon starts to blink when a USB flash drive is connected, and lights up when the USB flash drive is recognized by this transceiver. The icon is displayed in red when the remaining space is running low.	
		Appears when the timer function is enabled.	14-3
		Appears when a KNS user is connected to this transceiver.	15-2
	A B C	Displays the selected RX filter (A, B or C).	6-1
	LC:200 WIDTH:2600	Displays the low-cut frequency of the RX filter. Displays the width frequency of the RX filter.	6-3
	BW:2600	Displays the bandwidth of the RX filter.	
	HC:2800 SHIFT:1500	Displays the low-cut frequency of the RX filter. Displays the shift frequency of the RX filter.	6-6
		Displays the position of the notch frequency when the notch filter is ON.	
		Displays the passband/audio FFT. Displays the audio FFT spectrum of the RX or TX audio.	6-1 8-4
	1500	Displays the center indicator. • Indicates the pitch frequency when in the CW mode. • Indicates the center frequency of the passband when in the FSK or PSK mode. • Indicates the center frequency of the horizontal axis that is currently displayed when in the SSB, FM or AM mode.	5-9 5-17 5-22
	RFT:2.7k	Displays the selected bandwidth for the roofing filter.	6-2
F		Meter display • This can be switched to an analog or digital display. • Display of the information on the TX meter can be switched when an analog meter is displayed.	4-9
G	AUTO	Appears when the auto mode is ON.	4-4
	NR1 NR2	Appears when Noise Reduction 1 (NR1) is ON. Appears when Noise Reduction 2 (NR2) is ON.	6-7
	NB 1 NB 2 NB 1 2	Appears when Noise Blanker 1 (NB1) is ON. Appears when Noise Blanker 2 (NB2) is ON. Appears when both Noise Blanker 1 and 2 are ON.	6-5
	BC 1 BC 2	Appears when Beat Canceler 1 (BC1) is ON. Appears when Beat Canceler 2 (BC2) is ON.	6-8
	NOTCH W NOTCH M NOTCH N	Appears when the notch filter is ON and “Wide” is selected for the bandwidth. Appears when the notch filter is ON and “Middle” is selected for the bandwidth. Appears when the notch filter is ON and “Narrow” is selected for the bandwidth.	6-6
	SPLIT	Appears during split operation.	5-1

Area	Display	Description	Refer to
H		Displays the mode that is currently running. “-D” is displayed when in the data mode.	4-4
	 	Appears while receiving in the TX band. Appears while transmitting in the TX band. “-R” is displayed when in the reverse mode.	-
		Appears when configuring the frequency of the VFO mode or auto mode.	-
		Displays the entry history when the frequency entry mode is started up in the VFO mode.	4-7
		Appears when transmitting or receiving operation information that is called up from the memory channel. The memory channel numbers displayed are from 00 to 99, P0 to P9 and E0 to E9.	9-1
		Displays the quick memory channel mode. Displays one of the quick memory channel numbers from Q0 to Q9.	9-5
		Displays the VFO A/B and memory channel status that is being used during simplex or split operation.	-
		Displays the frequency used. (The frequency display on the right is grayed out during simplex operation.)	-
I		Appears when the MHz step function is enabled.	4-6
		Displays the name of the memory channel.	9-4
		Displays the scanning speed (when in a mode other than FM).	10-2
		Appears during program scanning, memory scanning or quick memory scanning.	10-1
		Appears during program slow-scan.	10-2
		Appears when CW auto tuning is running.	5-9
		Displays the band memory number according to the memory that is being called up.	4-3
		Appears when a channel to be locked out is selected.	10-4
		Displays the difference between the transmission frequency and reception frequency.	5-1
		Appears during playback.	12-4
		Appears while playback is paused.	
		Appears during recording.	12-3
J	Configuration Screen Bandscope	Displays the configuration screen or bandscope. This area is usually left blank.	-



3 MENU

Menu Operation

The settings of the different functions of this transceiver can be changed from the menu. It can also be used to switch the operating environment. There is also a list of frequently used menu items as well as “sub-menus” that are sorted by function.

Calling Up a Menu

1 Press [MENU] to display the menu screen.



2 Press F2 [▲]/F3 [▼] or [M.IN]/[▽] to select a group.
 3 Press F4 [SELECT] to display the menu items of the selected group.

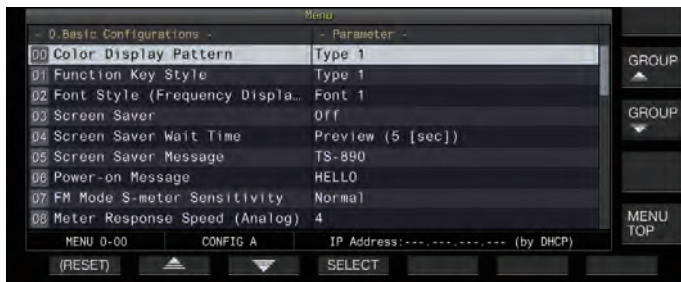

4 Press F2 [▲]/F3 [▼] or [M.IN]/[▽], or turn the [MULTI/CH] control to select the desired menu item.
 • Pressing F [GROUP ▲]/F [GROUP ▼] changes the group. (Refer to 3-3 Menu Items.)
 • Pressing F [MENU TOP] returns the menu screen to the top.
 5 Press F4 [SELECT] or [Q-MR>]. The parameter setting can now be changed.
 6 Press F4 [-]/F5 [+] or [M.IN]/[▽], or turn the [MULTI/CH] control to select the setting value.

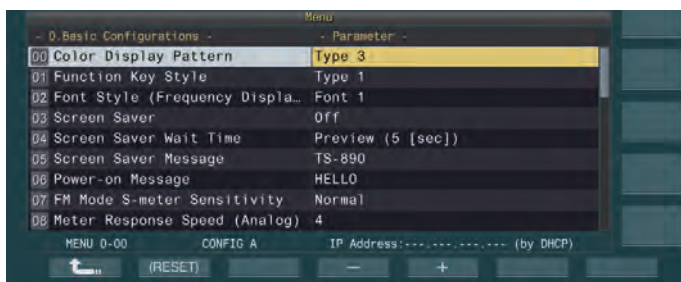

The setting switches to a different setting.
 • To restore the default setting of the selected menu, press and hold F2 [(RESET)].

7 Press F1 [↵] or [<Q-M.IN]. The selected content is confirmed.
 8 Press [MENU] or [ESC] to exit the menu screen.

In the subsequent descriptions on the menus, the expression “Configure in Menu [X-XX] 'Xxxx xxxx xxxxx'” will be used. (Example: Configure in Menu [3-06] “MHz Step”)

Calling Up a Sub-Menu

1 Press [MENU] to display the menu screen. The function keys of the sub-menu are displayed on the right side of the screen.
 2 Press F [MORE] to switch between sub-menu selection 1 and 2.
 3 Press the desired function key. The following sub-menus are displayed.

Sub-Menu	Key Guide	Behavior
Sub-Menu Selection 1		
Reset	RESET	Displays the Reset menu screen.
Advanced	ADV.	Displays the Advanced Menu screen.
Linear Amplifier	LINEAR AMP	Displays the Linear Amplifier menu screen.
Dimmer	DIMMER n	Short press: Switches the dimmer. Long press: Displays the Dimmer menu screen.
SWL	SWL	Displays the horizontal dial screen.
USB/File	USB /FILE	Displays the USB/File Management menu screen.
MORE	MORE	Switches to sub-menu selection 2.
Sub-Menu Selection 2		
Clock	CLOCK	Displays the Clock menu screen.
LAN	LAN	Displays the LAN menu screen.
Auto Mode	AUTO MODE	Displays the Auto Mode menu screen.
KNS	KNS	Displays the KNS menu screen.
Timer	TIMER	Short press: Switches the paused state of a timer. Long press: Displays the Timer menu screen.
Frequency Marker	F.MKR xxx	Short press: Switches the marker display. Long press: Displays the Frequency Marker menu screen.
MORE	MORE	Switches to sub-menu selection 1.

Advanced Menu

In the subsequent descriptions on the advanced menus, the expression “Configure in Advanced Menu [XX] 'Xxxx xxxx xxxxx'” will be used. (Example: Configure in Advanced Menu [9] “Antenna Tuner Operation per Band”)

3 MENU

Common Menu Screen Operations

- Pressing **F [MENU TOP]** returns the menu screen to the top.
- Pressing **F [GROUP ▲] / F [GROUP ▼]** switches the group.
- The menu item can be selected in the following ways.
 - Turn the **[MULTI/CH]** control.
 - Press **F2 [▲] / F3 [▼]**.
 - Press **[M.IN] / [▼]**.
 - Press **[UP]** or **[DOWN]** on the microphone.
- The setting value in the Parameter field can be selected in the following ways.
 - Turn the **[MULTI/CH]** control.
 - Press **[UP]** or **[DOWN]** on the microphone.
 - Press **F4 [-] / F5 [+]**.
 - Press **[M.IN] / [▼]**.
 - Press **[◀] / [▶]**.
- Pressing and holding **[(RESET)]** restores the altered setting value to the default setting.
- Pressing **F [MORE]** switches the key guide display.
- Pressing **F [○○○ TOP]** when configuring the sub-menu returns the sub-menu screen to the top.

Exiting the Menu

To exit configuration or editing on the menu screen or to end the configuration of a menu item halfway, follow the steps below. The menu screen closes and the display returns to the normal screen.

● Press [MENU] or [ESC].

- ✎ ● It is possible to reset only the menu settings.
- The menu items or default values may be altered.
- When editing the screen saver message or power-on message, pressing **[MENU]** will not exit the menu screen.

Switching between the CONFIG A and CONFIG B Operating Environments

“Operating environment” refers collectively to values configured in the menu as well as the different settings data for operation. Two different types of operating environment are available on this transceiver: CONFIG A and CONFIG B. Both CONFIG A and CONFIG B have the same functions and they can be configured independently of each other. For example, it is possible to configure CONFIG A for DX and CONFIG B for rag chew and switch easily between them.

1 Press [MENU] to display the menu screen.

The current operating environment (CONFIG A or CONFIG B) is displayed in the status bar of the menu screen. Also, data of the operating environment can be saved to and read from a transceiver or USB flash drive.

2 Press F7 [CONFIG].

A message appears.

- Press **F7 [CANCEL]** to return to the Menu screen.

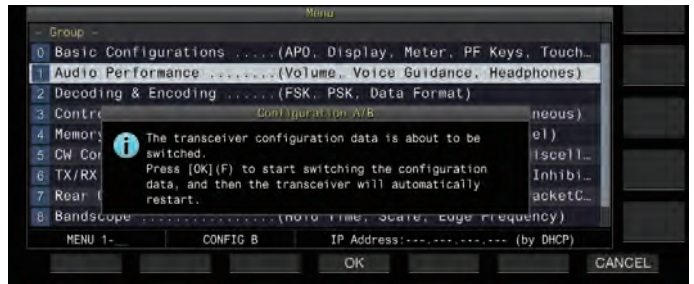

3 Press F4 [OK].

- Switches from CONFIG A to CONFIG B or vice versa, and this transceiver automatically restarts after switching is complete.

- ✎ ● The following are common settings between CONFIG A and B.
 - Number of quick memory channels
 - Baud rate of COM port
 - Baud rate of USB connector (virtual COM port) on the rear panel
 - Decoded character output
- Information and data other than those below are common between CONFIG A and B.
 - Advanced menu settings
 - LAN menu settings
 - Clock menu settings
 - Linear amplifier menu settings
 - Timer menu settings
 - Memory channel data (including quick memory and slow scan point data)
 - CW/RTTY/PSK message memory data
 - Band memory (frequency and mode)
 - Broadcast band memory data
 - Antenna selection (including drive output selection and antenna output selection for external receiver)
 - Preset data of antenna tuner
 - Internal audio file data of recording function (wav file)
 - Voice message memory data (wav file)
- If the operating environment is switched while the quick memory is called up by pressing **[Q-MR>]** (quick memory), the quick memory settings will be discarded before the operating environment switches.

Menu Items

Menu

- 0. Basic Configurations -					
Menu	Display	Description	Setting Value	Default	Refer to
Display					
0-00	Color Display Pattern	Display color type	Type 1/ Type 2/ Type 3	Type 1	4-1
0-01	Function Key Style	Type of function key display	Type 1/ Type 2/ Type 3	Type 1	4-1
0-02	Font Style (Frequency Display)	Font type (frequency display)	Font 1/ Font 2/ Font 3/ Font 4/ Font 5	Font 1	4-1
0-03	Screen Saver	Screen saver	Off/ Type 1/ Type 2/ Type 3/ Display Off	Off	16-1
0-04	Screen Saver Wait Time	Wait time for screen saver	Preview (5 [sec])/ 5/ 15/ 30/ 60 [min]	Preview (5 [sec])	16-1
0-05	Screen Saver Message	Screen saver message	Up to 10 alphanumeric characters	TS-890	16-1
0-06	Power-on Message	Power on message	Up to 15 alphanumeric characters	HELLO	16-1
Meter					
0-07	FM Mode S-Meter Sensitivity	FM S meter sensitivity	Normal/ High	Normal	4-9
0-08	Meter Response Speed (Analog)	Analog meter response	1 to 4 (1 step)	3	4-9
0-09	Meter Display Pattern	Meter type	Digital/ Analog (White)/ Analog (Black)	Analog (White)	4-9
0-10	Meter Display Peak Hold	Meter with peak hold	Off/ On	On	4-9
0-11	S-Meter Scale	S meter scale	Type 1/ Type 2	Type 1	4-9
0-12	TX Digital Meter	TX meter (digital)	Off/ On	Off	4-9
Key					
0-13	Long Press Duration of Panel Keys	Duration for pressing and holding a key	200 to 2000 [ms] (100 [ms] step)	500 [ms]	16-2
0-14	Touchscreen Tuning	Touchscreen tuning	Off/ On	On	7-4
0-15	PF A: Key Assignment	Function assignment to [PF A] key	Refer to PF (Programmable Function).	VOICE1	16-2
0-16	PF B: Key Assignment	Function assignment to [PF B] key	Refer to PF (Programmable Function).	VOICE2	16-2
0-17	PF C: Key Assignment	Function assignment to [PF C] key	Refer to PF (Programmable Function).	VOICE3	16-2
0-18	External PF 1: Key Assignment	Function assignment to [PF 1] on the keypad	Refer to PF (Programmable Function).	Message Memory CH 1	16-3
0-19	External PF 2: Key Assignment	Function assignment to [PF 2] on the keypad	Refer to PF (Programmable Function).	Message Memory CH 2	16-3
0-20	External PF 3: Key Assignment	Function assignment to [PF 3] on the keypad	Refer to PF (Programmable Function).	Message Memory CH 3	16-3
0-21	External PF 4: Key Assignment	Function assignment to [PF 4] on the keypad	Refer to PF (Programmable Function).	Message Memory CH 4	16-3
0-22	External PF 5: Key Assignment	Function assignment to [PF 5] on the keypad	Refer to PF (Programmable Function).	Message Memory CH 5	16-3
0-23	External PF 6: Key Assignment	Function assignment to [PF 6] on the keypad	Refer to PF (Programmable Function).	Message Memory CH 6	16-3
0-24	External PF 7: Key Assignment	Function assignment to [PF 7] on the keypad	Refer to PF (Programmable Function).	Message Memory CH 7	16-3
0-25	External PF 8: Key Assignment	Function assignment to [PF 8] on the keypad	Refer to PF (Programmable Function).	Message Memory CH 8	16-3
0-26	Microphone PF 1: Key Assignment	Function assignment to [PF 1] on the microphone	Refer to PF (Programmable Function).	A/B, A=B	16-3

3 MENU

- 0. Basic Configurations -					
Menu	Display	Description	Setting Value	Default	Refer to
Display					
0-27	Microphone PF 2: Key Assignment	Function assignment to [PF 2] on the microphone	Refer to PF (Programmable Function).	SPLIT	16-2
0-28	Microphone PF 3: Key Assignment	Function assignment to [PF 3] on the microphone	Refer to PF (Programmable Function).	M/V, M▶V	16-2
0-29	Microphone PF 4: Key Assignment	Function assignment to [PF 4] on the microphone	Refer to PF (Programmable Function).	MONI	16-2
0-30	Microphone DOWN: Key Assignment	Function assignment to [DOWN] on the microphone	Refer to PF (Programmable Function).	DWN Key (Microphone)	16-2
0-31	Microphone UP: Key Assignment	Function assignment to [UP] on the microphone	Refer to PF (Programmable Function).	UP Key (Microphone)	16-2
0-32	Automatic Power Off	APO (Automatic Power Off)	Off/ 60/ 120/ 180 [min]	Off	16-2
- 1. Audio Performance -					
Menu	Display	Description	Setting Value	Default	Refer to
Volume					
1-00	Beep Volume	Volume of beep tone	Off/ 1 to 20 (1 step)	10	16-2
1-01	Voice Message Volume (Play)	Playback volume of voice message	Off/ 1 to 20 (1 step)	10	12-2
1-02	Sidetone Volume	Sidetone volume	Off/ 1 to 20 (1 step)	10	5-9
Voice Guide					
1-03	Voice Guidance Volume	Voice guide volume	Off/ 1 to 20 (1 step)	10	13-1
1-04	Voice Guidance Speed	Voice guide speed	1 to 4 (1 step)	1	13-1
1-05	User Interface Language (Voice Guidance & Messages)	Language of voice guide and message display	English/ Japanese	English	13-1
1-06	Automatic Voice Guidance	Automatic voice guide	Off/ On	Off	13-1
- 2. Decoding & Encoding -					
Menu	Display	Description	Setting Value	Default	Refer to
FSK Decoding					
2-00	FFT Scope Averaging (RTTY Decode)	Averaging on the FFT scope (RTTY Decode)	0 to 9 (1 step)	0	5-24
2-01	RX UOS	RX unshift-on-space	Off/ On	On	5-21
2-02	Newline Code	New line code selection (during reception)	CR+LF/ All	All	5-21
2-03	Diddle	Diddle	Off/ Blank Code/ Letters Code	Blank Code	5-21
2-04	TX UOS	TX unshift-on-space	Off/ On	On	5-21
2-05	Automatic Newline Insertion	Automatic new line code insertion	On/ Off	On	5-21
FSK Key					
2-06	FSK Spacing	FSK shift width	170/ 200/ 425/ 850 [Hz]	170 [Hz]	5-21
2-07	FSK Keying Polarity	FSK keying polarity	Off/ On	Off	5-21
2-08	FSK Tone Frequency	FSK tone frequency	1275/ 2125 [Hz]	2125 [Hz]	5-21
2-09	RTTY Tuning Scope	Scope display for checking FSK tuning	FFT Scope/ X-Y Scope	FFT Scope	5-18
PSK Decoding					
2-10	FFT Scope Averaging (PSK Decode)	Averaging on the FFT scope (PSK Decode)	0 to 9 (1 step)	0	5-18
2-11	PSK AFC Tuning Range	Tuning range for PSK AFC	±15/ ±8 [Hz]	±15 [Hz]	5-24
2-12	PSK Tone Frequency	PSK tone frequency	1.0/ 1.5/ 2.0 [kHz]	1.5 [kHz]	5-27
2-13	PSK Tuning Scope	Scope display for checking PSK tuning	FFT Scope/ X-Y Scope	FFT Scope	5-18
Common					
2-14	CW/ RTTY/ PSK Log File Format	File format for saving CW/RTTY/ PSK logs	html/ txt	txt	5-27
2-15	CW/ RTTY/ PSK Time Stamp	CW/ RTTY/ PSK time stamp	Off/ Time Stamp/ Time Stamp + Frequency	Time Stamp + Frequency	5-27
2-16	Clock (CW/ RTTY/ PSK Time Stamp)	Clock selection for CW/ RTTY/ PSK time stamp	Local Clock/ Secondary Clock	Local Clock	5-27
2-17	Waterfall when Tuning (RTTY/ PSK Audio Scope)	Selection of RTTY/ PSK waterfall display type	Straight/ Follow	Straight	5-19 5-24

- 3. Controls Configurations -					
Menu	Display	Description	Setting Value	Default	Refer to
Control Rate					
3-00	Frequency Rounding Off (Multi/ Channel Control)	Rounds off the frequency of the [MULTI/CH] control	Off/ On	On	4-6
3-01	SSB Mode Frequency Step Size (Multi/ Channel Control)	SSB frequency step size	0.5/ 1/ 2.5/ 5/ 10 [kHz]	1 [kHz]	4-6
3-02	CW/FSK/PSK Mode Frequency Step Size (Multi/Channel Control)	CW/ FSK/ PSK frequency step size	0.5/ 1/ 2.5/ 5/ 10 [kHz]	0.5 [kHz]	4-6
3-03	FM Mode Frequency Step Size (Multi/ Channel Control)	FM frequency step size	5/ 6.25/ 10/ 12.5/ 15/ 20/ 25/ 30/ 50/ 100 [kHz]	10 [kHz]	4-6
3-04	AM Mode Frequency Step Size (Multi/ Channel Control)	AM frequency step size	5/ 6.25/ 10/ 12.5/ 15/ 20/ 25/ 30/ 50/ 100 [kHz]	5 [kHz]	4-6
3-05	9 kHz Step in AM Broadcast Band (Multi/ Channel Control)	Steps of the [MULTI/CH] control in the BC band (AM)	Off/ On	K type: Off E type: On	4-6
3-06	MHz Step	MHz step	100/ 500/ 1000 [kHz]	1000 [kHz]	4-6
3-07	Tuning Control: Number of Steps per Revolution	Number of steps per revolution of the Tuning control	250/ 500/ 1000 [Step]	1000 [Step]	4-6
3-08	Tuning Speed Control	Fast forward rate of the Tuning control	Off/ 2 to 10 (1 step)	Off	4-6
3-09	Tuning Speed Control Sensitivity	Sensitivity of the Tuning control for starting the fast forward operation	1 to 10 (1 step)	5	4-6
3-10	Lock Function	Frequency lock function	Frequency Lock/ Tuning Control Lock	Frequency Lock	4-6
3-11	Number of Band Memories	Number of band memories	1/ 3/ 5	3	4-3
3-12	Split Frequency Offset by RIT/XIT Control	Changing the split frequency using the [RIT/XIT] control	Off/ TX Frequency Offset while RX/ RX Frequency Offset while TX/ Both	Off	5-1
3-13	Band Direct Keys in Split Mode	Band direct key during split operation	RX Band/ RX Band and Cancel Split Mode/ RX/ TX Band	RX Band	5-1

- 4. Memory Channels & Scan -					
Menu	Display	Description	Setting Value	Default	Refer to
Memory					
4-00	Number of Quick Memory Channels	Number of quick memory channels	3/ 5/ 10 [ch]	5 [ch]	9-5
4-01	Temporary Change (Memory Channel Configurations)	Temporary change of memory frequency	Off/ On	Off	9-3
Scan					
4-02	Program Slow Scan	Program slow scan	Off/ On	On	10-2
4-03	Program Slow Scan Range	Range of program slow scan	100/ 200/ 300/ 400/ 500 [Hz]	300 [Hz]	10-3
4-04	Scan Hold	Scan Hold	Off/ On	Off	10-3
4-05	Scan Resume	Scan resume condition	Time-operated/ Carrier-operated	Time-operated	10-4

- 5. CW Configurations -					
Menu	Display	Description	Setting Value	Default	Refer to
Jack Terminals					
5-00	Paddle Jack Configuration (Front)	PADDLE jack (front panel) function setting	Straight Key/ Paddle/ Paddle (Bug Key Mode)	Paddle	5-13
5-01	Key Jack Configuration (Rear)	KEY jack (rear panel) function setting	Straight Key/ Paddle/ Paddle (Bug Key Mode)	Straight Key	5-13
Mode					
5-02	Electronic Keyer Squeeze Mode	Operation mode of the electronic keyer	Mode A/ Mode B	Mode B	5-13
5-03	Dot and Dash Reversed Keying	Switches between dot and dash paddle	Off/ On	Off	5-13
5-04	Paddle (Microphone Up/Down Keys)	Paddle ([UP] and [DOWN] keys on microphone)	Off/ On	Off	5-13
5-05	CW BFO Side Band	CW BFO sideband	USB/ LSB	USB	5-9

3 MENU

- 5. CW Configurations -					
Menu	Display	Description	Setting Value	Default	Refer to
Weight and Timing					
5-06	Automatic CW TX with Keying in SSB Mode	CW transmission by keying in the SSB mode	Off/ On	Off	5-9
5-07	Carrier Frequency Offset (SSB Mode to CW Mode)	Carrier frequency correction when shifting from the SSB mode to CW mode	Off/ On	Off	5-9
5-08	CW Keying Weight Ratio	Keyer weight	Automatic/ 2.5 to 4.0 (0.1 step)	Automatic	5-13
5-09	CW Keying Reversed Weight Ratio	Reverse keying auto weight ratio	Off/ On	Off	5-13
5-10	Interrupt Keying	Insert keying	Off/ On	Off	5-17
Memory					
5-11	CW Message Entry	Method for registering CW message	Text String/ Paddle	Paddle	5-14
5-12	Contest Number	Contest number	001 to 9999 (1 step)	001	5-15
5-13	Contest Number Format	Contest number style	Off/ 190 to ANO/ 190 to ANT/ 90 to NO/ 90 to NT	Off	5-15
5-14	Channel Number (Count-up Message)	Specifies the channel used for the count-up message	Off/ Channel 1 to Channel 8	Off	5-15
5-15	CW Rise Time	CW rise time	1/ 2/ 4/ 6 [ms]	6 [ms]	5-9
5-16	CW/ Voice Message Retransmit Interval Time	Repeat interval for retransmitting CW/voice message	0 to 60 [s] (1 [s] step)	10 [s]	5-17 12-2
- 6. TX/RX Filter & Misc. -					
Menu	Display	Description	Setting Value	Default	Refer to
Message					
6-00	Playback Time (Full-time Recording)	Playback time for constantly recorded audio	Last 10/ Last 20/ Last 30 [s]	Last 30 [s]	12-3
6-01	Recording with Squelch	Audio recording in tandem with squelch	Off/ On	On	12-3
TX Management					
6-02	Time-out Timer	Maximum continuous transmission time (Timeout timer)	Off/ 3/ 5/ 10/ 20/ 30 [min]	Off	8-8
6-03	TX Inhibit	Inhibits transmission	Off/ On	Off	16-11
6-04	Transmit Power Step Size	Fine adjustment of TX output power	1/ 5 [W]	5 [W]	4-8
6-05	ID Beep	ID beep	Off/ 1 to 30 [min] (1 step)	Off	8-8
Filter					
6-06	TX Filter Low Cut (SSB/AM)	Low-cut frequency of the TX filter (SSB/AM)	10/ 100/ 200/ 300/ 400/ 500 [Hz]	100 [Hz]	8-5
6-07	TX Filter High Cut (SSB/AM)	High-cut frequency of the TX filter (SSB/AM)	2500/ 2600/ 2700/ 2800/ 2900/ 3000/ 3500/ 4000 [Hz]	2900 [Hz]	8-5
6-08	TX Filter Low Cut (SSB-DATA/AM-DATA)	Low-cut frequency of the TX filter (SSB-DATA/AM-DATA)	10/ 100/ 200/ 300/ 400/ 500 [Hz]	100 [Hz]	8-5
6-09	TX Filter High Cut (SSB-DATA/AM-DATA)	High-cut frequency of the TX filter (SSB-DATA/AM-DATA)	2500/ 2600/ 2700/ 2800/ 2900/ 3000/ 3500/ 4000 [Hz]	2900 [Hz]	8-5
6-10	RX Filter Numbers	Number of RX filters	2/ 3	3	6-1
6-11	Filter Control in SSB Mode (High/Low and Shift/Width)	Switches between High-cut/low-cut and WIDTH/SHIFT (SSB)	High & Low Cut/ Shift & Width	High & Low Cut	6-2
6-12	Filter Control in SSB-DATA Mode (High/Low and Shift/Width)	Switches between High-cut/low-cut and WIDTH/SHIFT (SSB-DATA)	High & Low Cut/ Shift & Width	Shift & Width	6-2
6-13	VOX Voice Delay (Microphone)	Audio delay in the VOX mode (MIC)	Off/ Short/ Middle/ Long	Middle	8-2
6-14	VOX Voice Delay (Except Microphone)	Audio delay in the VOX mode (excluding MIC)	Off/ Short/ Middle/ Long	Middle	8-2
6-15	Delta Frequency Display	ΔF display setting	Off/ On	On	5-1

- 7. Rear Connectors -					
Menu	Display	Description	Setting Value	Default	Refer to
Baud Rate					
7-00	Baud Rate (COM Port)	Baud rate of COM connector	4800/ 9600/ 19200/ 38400/ 57600/ 115200 [bps]	9600 [bps]	16-5
7-01	Baud Rate (Virtual Standard COM)	Baud rate of virtual COM (Standard) connector	9600/ 19200/ 38400/ 57600/ 115200 [bps]	115200 [bps]	16-5
7-02	Baud Rate (Virtual Enhanced COM)	Baud rate of virtual COM (Enhanced) connector	9600/ 19200/ 38400/ 57600/ 115200 [bps]	115200 [bps]	16-12
7-03	Decoded Character Output	Decoded character output	Off/ On	Off	16-12
Data transfer					
7-04	Quick Data Transfer	Quick data transfer	Off/ 1 (TX/RX)/ 1 (Sub RX)/ 2	Off	16-9
7-05	Overwrite Location (Quick Data Transfer)	Destination for data via quick data transfer	VFO/ Quick Memory	Quick Memory	16-9
Audio input					
7-06	USB: Audio Input Level	USB audio input level	0 to 100 (1 step)	50	16-7
7-07	ACC 2: Audio Input Level	Audio input level of ACC 2 connector	0 to 100 (1 step)	50	16-7
Audio output					
7-08	USB: Audio Output Level	USB audio output level	0 to 100 (1 step)	100	16-7
7-09	ACC 2: Audio Output Level	Audio output level from ACC 2 connector	0 to 100 (1 step)	50	16-7
7-10	TX Monitor Level (Rear Connectors)	TX monitor level output to the rear panel connector	Linked/ 0 to 20 (1 step)	Linked	16-7
7-11	Audio Output Type (Rear Connectors)	Format of audio output from the rear panel connector	All/ Received Audio only	All	16-7

- 8. Bandscope -					
Menu	Display	Description	Setting Value	Default	Refer to
Common					
8-00	Bandscope Display during TX	Bandscope display during transmission	Off/ On	Off	7-6
8-01	TX Audio Waveform Display	Waveform display for transmitted audio	On/ Off	On	8-4
8-02	Bandscope Maximum Hold	Maximum hold time	10 [s]/ Continuous	10 [s]	7-5
8-03	Waterfall when Tuning (Center Mode)	Waterfall display during tuning (center mode)	Straight/ Follow	Straight	7-2
8-04	Waterfall Gradation Level	Gradation setting of the waterfall	1 to 10 (1 step)	7	7-4
8-05	Tuning Assist Line (SSB Mode)	Auxiliary tuning line display (SSB only)	Off/ 300/ 400/ 500/ 600/ 700/ 800/ 1000/ 1500/ 2210 [Hz]	Off	7-4
8-06	Frequency Scale (Center Mode)	Frequency scale in the center mode	Relative Frequency/ Absolute Frequency	Relative Frequency	7-2
8-07	Touchscreen Tuning Step Correction (SSB/ CW/ FSK/ PSK)	Correction steps for touchscreen tuning	Off/ On	On	7-5

- 9. USB Keyboard -					
Menu	Display	Description	Setting Value	Default	Refer to
USB keyboard					
9-00	Send Message by Function Keys	Function key settings of USB keyboard	Off/ On	On	16-5
9-01	Keyboard Language	USB keyboard language	Japanese/ English (US)/ English (UK)/ French/ French (Canadian)/ German/ Portuguese/ Portuguese (Brazilian)/ Spanish/ Spanish (Latin American)/ Italian	English (US)	16-5
9-02	Repeat Delay Time	Key repeat delay time for USB keyboard	1 to 4 (1 step)	2	16-5
9-03	Repeat Speed	Key repeat speed for USB keyboard	1 to 32 (1 step)	1	16-5

3 MENU

Advanced Menu Items

Menu	Display	Description	Setting Value	Default	Refer to
0	Indication Signal Type (External Meter 1)	Target of external meter output 1	Automatic/ TX Power/ ALC/ Drain Voltage (Vd)/ Compression Level (COMP)/ Current (Id)/ SWR	TX Power	16-6
1	Indication Signal Type (External Meter 2)	Target of external meter output 2	Automatic/ TX Power/ ALC/ Drain Voltage (Vd)/ Compression Level (COMP)/ Current (Id)/ SWR	Automatic	16-6
2	Output Level (External Meter 1)	Level of external meter output 1	0 to 100 [%] (1 step)	50 [%]	16-6
3	Output Level (External Meter 2)	Level of external meter output 2	0 to 100 [%] (1 step)	50 [%]	16-6
4	Reference Signal Source	Switches the reference signal	Internal/ External	Internal	16-8
5	Reference Oscillator Calibration	Adjusts the frequency of the reference oscillator	-500 to +500 (1 step)	0	17-2
6	TX Power Down with Transverter Enabled	Powers down the transverter function	Off/ On	On	16-15
7	TX Hold After Antenna Tuning	Holds transmission at the end of antenna tuning	Off/ On	Off	4-11
8	Antenna Tuner during RX	Antenna tuner behavior while receiving	Off/ On	Off	4-12
9	Antenna Tuner Operation per Band	Antenna tuner behavior for each band	Off/ On	Off	4-12
10	Microphone Gain (FM Mode)	FM microphone gain	0 to 100 (1 step)	50	5-28
11	PKS Polarity Reverse	Reversing of PSK polarity	Off/ On	Off	16-12
12	TX Inhibit While Busy	Inhibits transmission while in the BUSY state	Off/ On	Off	16-12
13	CTCSS Unmute for Internal Speaker	Mute behavior of CTCSS	Mute/ Unmute	Mute	16-8
14	PSQ Logic State	SQL control signal logic	Low/ Open	Low	16-8
15	PSQ Reverse Condition	SQL output conditions	Off/ Busy/ Sql/ Send/ Busy-Send/ Sql-Send	Sql	16-8
16	PSQ/ PKS Pin Assignment (COM Connector)	PSQ/PKS mode setting	Off/ On	Off	16-8
17	Virtual Standard COM Port - RTS	RTS settings of virtual COM port (Standard)	Flow Control/ CW Keying/ RTTY Keying/ PTT/ DATA SEND	Flow Control	16-12
18	Virtual Standard COM Port - DTR	DTR settings of virtual COM port (Standard)	Off/ CW Keying/ RTTY Keying/ PTT/ DATA SEND	Off	16-12
19	Virtual Enhanced COM Port - RTS	RTS settings of virtual COM port (Standard)	Off/ CW Keying/ RTTY Keying/ PTT/ DATA SEND	Off	16-12
20	Virtual Enhanced COM Port - DTR	RTS settings of virtual COM port (Standard)	Off/ CW Keying/ RTTY Keying/ PTT/ DATA SEND	Off	16-12
21	External Display	External display output	Off/ On	On	16-7
22	Resolution (External Display)	Resolution settings of external display	800 x 600/ 848 x 480	800 x 600	16-7
23	Touchscreen Calibration	Touchscreen adjustment	-	-	17-3
24	Software License Agreement	Software license of this transceiver	-	-	i
25	Important Notices concerning Free Open Source	Ways to obtain open source resources used by this transceiver	-	-	ii
26	About Various Software License Agreements	Licenses related to software used by this transceiver	-	-	ii
27	Firmware Version	Firmware version used by this transceiver	-	-	17-1

Reset Menu Items

Display	Description	Refer to
Menu Reset	Menu reset	17-1
Memory Channel Reset	Memory channel reset	
VFO Reset	VFO reset	
Standard Reset (The Clock, TX Inhibit, and Transmit Power Upper Limit will not be reset)	Standard reset	
Full Reset	Full reset	

Linear Amplifier Menu Items

Display	Description	Setting Value	Default	Refer to
Band	Target bands of the linear amplifier menu	HF/ 50M/ 70M (E type)	HF	16-14
Linear Amplifier	Linear amplifier ON/OFF	Off/ On	Off	
Keying Logic	Linear amplifier TX control	Active Low/ Active High	Active Low	
TX Delay	Linear amplifier TX delay ON/OFF	Off/ On	Off	
TX Delay Time (CW/FSK/PSK)	Linear amplifier TX delay time (CW/FSK/PSK)	5/ 10/ 15/ 20/ 25/ 30/ 35/ 40 [ms]	15 [ms]	
TX Delay Time (SSB/FM/AM)	Linear amplifier TX delay time (SSB/FM/AM)	5/ 10/ 15/ 20/ 25/ 30/ 35/ 40/ 45/ 50 [ms]	35 [ms]	
Internal Relay Control	Linear amplifier relay control	Off/ On	Off	
External ALC Voltage	Linear amplifier external ALC voltage	-1/ -2/ -3/ -4/ -5/ -6/ -7/ -8/ -9/ -10/ -11/ -12 [V]	-4 [V]	

Dimmer Menu Items

Dimmer	Display	Description	Setting Value	Default	Refer to
1	Display	Screen brightness	5 to 100 (5-step)	100	4-2
	LED	LED brightness	5 to 100 (5-step)	100	
2	Display	Screen brightness	5 to 100 (5-step)	75	
	LED	LED brightness	5 to 100 (5-step)	75	
3	Display	Screen brightness	5 to 100 (5-step)	50	
	LED	LED brightness	5 to 100 (5-step)	50	
4	Display	Screen brightness	0 to 100 (5-step)	25	
	LED	LED brightness	5 to 100 (5-step)	25	

USB/File Management Menu Items

Display	Description	Setting Value	Default	Refer to
Safe Removal of USB Flash Drive	Removes the USB flash drive safely	-	-	11-6
Read Configuration Data	Reads transceiver settings data	-	-	11-3
Save Configuration Data	Saves transceiver settings data	-	-	11-2
Copy Files to PC (via USB cable)	Copies files to PC (via USB cable)	-	-	11-4
Copy Files to USB Flash Drive	Copies files to USB flash drive	-	-	11-5
Read Image Files for Screen Saver (Type 3)	Reads images for screen saver	-	-	16-1
Delete Files (Internal Memory)	Deletes files stored in the internal memory of the transceiver	-	-	11-5
File Storage Location	Configures the destination for saving files	Internal Memory/ USB Flash Drive	Internal Memory	11-2
Format USB Flash Drive	USD flash drive format	-	-	11-5

3 MENU

Clock Menu Items

Menu	Display	Description	Setting Value	Default	Refer to
0.Date and Time					
0-00	Date (Local Clock)	Date of the local clock	Year: '18 (2018) to '99 (2099) Month: JAN/ FEB/ MAR/ APR/ MAY/ JUN/ JUL/ AUG/ SEP/ OCT/ NOV/ DEC Day: 01 to 31	Year: '18 Month: JAN Day: 01	14-1
0-01	Time (Local Clock)	Time of the local clock	00:00 to 23:59 (hour: 00 to 23, minute: 00 to 59)	00:00	
0-02	Timezone (Local Clock)	Time zone of the local clock	UTC -14:00 to UTC ±00:00 to UTC +14:00 (15-minute step)	UTC +00:00	
0-03	Timezone (Secondary Clock)	Time zone of the auxiliary clock	UTC -14:00 to UTC ±00:00 to UTC +14:00 (15-minute step)	UTC +00:00	
0-04	Secondary Clock Identification Letter	Auxiliary clock identifier	Single character (A to Z)	U	
0-05	Date Display Format	Date display format	MMM/DD/'YY, DD/MMM/'YY, 'YY/ MMM/ DD	K type: MMM/ DD/'YY E type: DD/ MMM/'YY	14-2
0-06	Clock Display	Clock display setting	Off/ Local Clock/ Secondary Clock/ Both	Both	
1.Automatic Time Correction					
1-00	Clock Correction using the NTP Server	Automatic clock setting (NTP)	Off/ On	Off	14-3
1-01	NTP Server Address	NTP server address	Up to 50 alphanumeric characters	Blank	

LAN Menu Items

Menu	Display	Description	Setting Value	Default	Refer to
0	DHCP	DHCP	Off/ On	On	15-1
1	IP Address	IP address	1.0.0.0 to 223.255.255.255	192.168.1. 100	
2	Subnet Mask	Subnet mask	0.0.0.0 to 255.255.255.252	255.255.255. 0	
3	Default Gateway	Default gateway	1.0.0.0 to 223.255.255.255	Blank	
4	Primary DNS Server	Primary DNS server	1.0.0.0 to 223.255.255.255	Blank	
5	Secondary DNS Server	Secondary DNS server	1.0.0.0 to 223.255.255.255	Blank	
6	MAC Address	MAC address	-	Fixed value for each transceiver	

Timer Menu Items

Display	Description	Setting Value	Default	Refer to
Programmable Timer				
Timer Mode	Type of program timer behavior	Off/ Power-on/ Power-off/ Power- on/ off/ Record	Off	14-3
Repeat	Repeat setting for program timer behavior	Off/ On	Off	
Day of the Week - Sun	Day of week setting for activating program timer - Sun	Check/ Uncheck	Check	
Day of the Week - Mon	Day of week setting for activating program timer - Mon	Check/ Uncheck	Check	
Day of the Week - Tue	Day of week setting for activating program timer - Tue	Check/ Uncheck	Check	
Day of the Week - Wed	Day of week setting for activating program timer - Wed	Check/ Uncheck	Check	
Day of the Week - Thu	Day of week setting for activating program timer - Thu	Check/ Uncheck	Check	
Day of the Week - Fri	Day of week setting for activating program timer - Fri	Check/ Uncheck	Check	
Day of the Week - Sat	Day of week setting for activating program timer - Sat	Check/ Uncheck	Check	
Power-on Time	Program timer operation time start	00:00 to 23:59	00:00	
Power-off Time	Program timer operation time end	00:00 to 23:59	00:00	

Display	Description	Setting Value	Default	Refer to
Programmable Timer				
Frequency/Mode	Frequency during program timer operation	30.000 kHz to 59.999.999 MHz	14.000.000	14-3
	Mode during program timer operation	LSB/ USB/ CW/ CW-R/ PSK/ PSK-R/ FSK/ FSK-R/ FM/ AM/ LSB-DATA/ USB-DATA/ FM-DATA/ AM-DATA	USB	
Sleep Timer				
Sleep Timer	Sleep timer	Off/ 5/ 10/ 15/ 30/ 60/ 90/ 120 [min]	Off	14-5

Auto Mode Menu Items

Display	Description	Setting Value	Default	Refer to
Auto Mode	Auto mode ON/OFF status	Auto Mode Off/ Auto Mode On	Auto Mode Off	4-4
Frequency	Frequency category of auto mode (#0)	30.000 kHz to 59.999990 MHz	9.5 MHz	
Mode	Mode of auto mode (#0)	LSB/ USB/ CW/ CW-R/ PSK/ PSK-R/ FSK/ FSK-R/ FM/ AM/ LSB-DATA/ USB-DATA/ FM-DATA/ AM-DATA	LSB	

KNS Menu Items

Menu	Display	Description	Setting Value	Default	Refer to
0	KNS Operation (LAN Connector)	KNS operation (LAN connection)	Off/ On (LAN)/ On (Internet)	Off	15-3
1	Administrator ID	KNS administrator ID	1 to maximum 32 alphanumeric characters	Blank	
2	Administrator Password	KNS administrator password	1 to maximum 32 alphanumeric characters	Blank	
3	Built-in VoIP	Built-in VoIP function	Off/ On	On	15-4
4	Audio Input Level (VoIP)	VoIP outgoing audio input level	0 to 100 (1 step)	50	
5	Audio Output Level (VoIP)	VoIP incoming audio output level	0 to 100 (1 step)	100	
6	VoIP Jitter Buffer	VoIP jitter absorption buffer	200/ 500/ 800 [ms]	200 [ms]	
7	Prohibit AF Gain Control	Prohibits volume control	Off/ On	Off	
8	Access Log	Log function	Off/ On	Off	15-6
9	Registered Users' Remote Operation	Remote operation by registered user	Off/ On	Off	
10	Session Time	Session time	1 [min]/ 2 [min]/ 3 [min]/ 5 [min]/ 10 [min]/ 15 [min]/ 20 [min]/ 30 [min]/ 40 [min]/ 50 [min]/ 60 [min]/ 90 [min]/ 120 [min]/ Unlimited	Unlimited	
11	KNS Welcome Message	KNS welcome message	Up to 128 single-byte alphanumeric characters	Blank	

Frequency Marker Menu Items

Display	Description	Setting Value	Default	Refer to
Frequency	Marker frequency (#0 to 49)	30.000 kHz to 59.999.999 MHz	-	7-5

