

FCC/ IC REPORT

Certification

Applicant Name:
JVC KENWOOD Corporation

Address:
1-16-2, Hakusan Midori-ku, Yokohama-
shi, Kanagawa, 226-8525 JAPAN

Date of Issue:
January 08, 2019

Test Site/Location:
HCT CO., LTD., 74,Seoicheon-ro 578beon-gil,Majang-
myeo,Icheon-si, Gyeonggi-do, 17383, Rep. of KOREA

Report No.: HCT-R-1812-FI003-R1

FCC ID:	K44502500
IC:	282F-502500
APPLICANT:	JVC KENWOOD Corporation

FCC/IC Model: NX-3400-K3
FCC Additional Model: NX-3420-K3, NX-3420-M3, NX-3420-M
IC Additional Model: NX-3420-K3
EUT Type: 800/900MHz DIGITAL TRANSCEIVER
Frequency Range: 806-824 MHz, 851-869 MHz, 896-901 MHz,
935-940 MHz, 901-902 MHz, 940-941 MHz
FCC Rule Part(s): Part 90, Part 24D, Part 2
RSS- Gen Issue 5 (April 2018),
IC Rule: RSS-119 Issue 12 (May 2015),
RSS-134 Issue 2 (February 2016)

The measurements shown in this report were made in accordance with the procedures specified in §2.947. I assume full responsibility for the accuracy and completeness of these measurements, and for the qualifications of all persons taking them.

HCT CO., LTD. Certifies that no party to this application has subject to a denial of Federal benefits that includes FCC benefits pursuant to section 5301 of the Anti-Drug Abuse Act of 1998,21 U.S. C.853(a)



Report prepared by : Jung Ki Lim
Engineer of Telecommunication testing center



Approved by : Jong Seok Lee
Manager of Telecommunication testing center

This report only responds to the tested sample and may not be reproduced, except in full, without written approval of the HCT Co., Ltd.

Version

TEST REPORT NO.	DATE	DESCRIPTION
HCT-RF-1812-FI003	December 28, 2018	- First Approval Report
HCT-RF-1812-FI003-R1	January 08, 2019	- Revised the PMN, HVIN on page 5

Table of Contents

1. GENERAL INFORMATION	4
2. EUT DESCRIPTION	5
3.CHANNEL BANDWIDTH	6
4.TEST CHANNEL	7
5. TEST METHODOLOGY	8
5.1 EUT CONFIGURATION	8
5.2 EUT EXERCISE	8
5.3 GENERAL TEST PROCEDURES	8
5.4 DESCRIPTION OF TEST MODES	8
6. INSTRUMENT CALIBRATION.....	9
7. FACILITIES AND ACCREDITATIONS	9
7.1 FACILITIES	9
7.2 EQUIPMENT	9
8. WORST CASE CONFIGURATION AND MODE	10
9. SUMMARY TEST OF RESULTS	11
10. TEST RESULT	15
10.1 Carrier Output Power	15
10.2 Carrier Frequency Stability	18
10.3 Occupied Bandwidth.....	40
10.4 Modulation Limiting	92
10.5 Audio Frequency Response / Audio Low Pass Filter Response.....	119
10.6 Emission Mask.....	147
10.6.1 Emission Mask EA(\$90.691)	149
10.6.2 Emission Mask §24D	177
10.6.3 Emission Mask B	187
10.6.4 Emission Mask I	223
10.6.5 Emission Mask D.....	243
10.6.6 Emission Mask E	261
10.7 Unwanted Emissions : Conducted Spurious Emission	273
10.8 Unwanted Emissions : Radiated Spurious Emission	330
10.9 Unwanted Emissions : Receiver Radiated Spurious Emission.....	352
10.10 Necessary Bandwidth Calculations	357
11. LIST OF TEST EQUIPMENT	359
12. ANNEX A_ TEST SETUP PHOTO.....	361

1. GENERAL INFORMATION

Manufacturer:	JVC KENWOOD Corporation
Address:	1-16-2, Hakusan Midori-ku, Yokohama-shi, Kanagawa, 226-8525 JAPAN
EUT Type:	800/900MHz DIGITAL TRANSCEIVER
FCC/IC Model:	NX-3400-K3
FCC Additional Model:	NX-3420-K3, NX-3420-M3, NX-3420-M
IC Additional Model:	NX-3420-K3
Date(s) of Tests	November 26, 2018 ~ December 14, 2018
Place of Tests:	HCT Co., Ltd. 74, Seoicheon-ro 578beon-gil, Majang-myeon, Icheon-si, Gyeonggi-do, 17383, Rep. of KOREA

2. EUT DESCRIPTION

Power Supply Voltage	DC 7.5 V
Antenna Type	- KRA-32: 700/800 MHz WHIP Antenna - KRA-36: 700/800 MHz Stuby Antenna - KRA-38: 800/900 MHz WHIP Antenna - KRA-39: 700/800 MHz Stuby Antenna
Peak Antenna gain	- KRA-32: 0 dBd - KRA-36: 0 dBd - KRA-38: 0 dBd - KRA-39: 0 dBd
Output Power	3 W (Power output continuously variable to 1 W) (Max: 3.3 W)
Battery type	- KNB-79LC: Li-Ion Battery Pack (2860mAh) - KNB-78L: Li-Ion Battery Pack (2860mAh) - KBP-5: AA Alkaline Battery Pack - KNB-57L: Li-Ion Battery Pack (2000mA) - KNB-56N: Ni-MH Battery Pack (1400mA) - KNB-55L: Li-Ion Battery Pack (1480mA)
Type of Emission	- 16K0F3E: Analogue - 14K0F3E: Analogue - 11K0F3E: Analogue - 8K30F1E, 8K30F1D, 8K30F7W: NXDN - 7K60FXE, 7K60FXD: DMR - 4K00F1E, 4K00F1D, 4K00F7W: NXDN - 4K00F2D: CWID
Maximum deviation:	- 16K0F3E: ± 5 kHz - 14K0F3E: ± 4 kHz - 11K0F3E: ± 2.5 kHz
Frequency Range	- Part90(IC RSS-119 Issue 12): 806-824 MHz, 851-869 MHz, 896-901 MHz, 935-940 MHz - Part24D(IC RSS-134 Issue 2): 901-902 MHz, 940-941 MHz
PMN	NX-3400-K3, NX-3420-K3
HVIN	NX-3400-K3, NX-3420-K3
FVIN	N/A
HMN	N/A
Frequency Stability	± 0.4 ppm

3.CHANNEL BANDWIDTH

FCC Part90 (IC RSS-119 Issue 12)	25 kHz	<p><u>16K0F3E:</u> 806-824, 851-869 MHz</p> <p><u>14K0F3E:</u> 806-824, 851-869 MHz</p>
	12.5 kHz	<p><u>11K0F3E:</u> 806-824 MHz, 851-869 MHz, 896-901 MHz, 935-940 MHz</p> <p><u>8K30F1E, 8K30F1D, 8K30F7W:</u> 806-824 MHz, 851-869 MHz, 896-901 MHz, 935-940 MHz</p> <p><u>7K60FXE, 7K60FXD:</u> 806-824 MHz, 851-869 MHz, 896-901 MHz, 935-940 MHz</p>
	6.25 kHz	<p><u>4K00F1E, 4K00F1D, 4K00F7W:</u> 806-824 MHz, 851-869 MHz, 896-901 MHz, 935-940 MHz</p> <p><u>4K00F2D:</u> 806-824 MHz, 851-869 MHz, 896-901 MHz, 935-940 MHz</p>

FCC Part24D (IC RSS-134 Issue 2)	50 kHz	<p><u>11K0F3E:</u> 901-902 MHz, 940-941 MHz</p> <p><u>8K30F1E, 8K30F1D, 8K30F7W:</u> 901-902 MHz, 940-941 MHz</p> <p><u>7K60FXE, 7K60FXD:</u> 901-902 MHz, 940-941 MHz</p>
	12.5 kHz	<p><u>4K00F1E, 4K00F1D, 4K00F7W:</u> 901-902 MHz, 940-941 MHz</p> <p><u>4K00F2D:</u> 901-902 MHz, 940-941 MHz</p>

4. TEST CHANNEL

Test Description	FCC Part90 (IC RSS-119 Issue 12) [MHz]	FCC Part24D (IC RSS-134 Issue 2) [MHz]
<ul style="list-style-type: none"> - RF Output Power - Conducted Unwanted Emissions - 99% Bandwidth - Carrier Frequency Stability 	25 kHz: 806.05, 851.05, 868.95 12.5 kHz: 806.05, 851.05, 868.95, 896.05, 900.95, 939.95 6.25 kHz: 806.05, 851.05, 868.95, 896.05, 900.95, 939.95	901.55, 940.55
<ul style="list-style-type: none"> - Audio Frequency Response - Audio Low Pass Filter - Modulation Limiting 	25 kHz: 806.05, 851.05, 868.95 12.5 kHz: 806.05, 851.05, 868.95, 896.05, 900.95, 939.95	901.55, 940.55
Emission Mask	25 kHz: 806.05, 851.05, 868.95 12.5 kHz: 806.05, 851.05, 868.95, 896.05, 900.95, 939.95 6.25 kHz: 806.05, 851.05, 868.95, 896.05, 900.95, 939.95	901.55, 940.55
<ul style="list-style-type: none"> - Field Strength of Spurious Radiation - Receiver Spurious Emissions 	25 kHz: 806.05, 851.05, 868.95 12.5 kHz: 806.05, 851.05, 868.95, 896.05, 900.95, 939.95 6.25 kHz: 806.05, 851.05, 868.95, 896.05, 900.95, 939.95	901.55, 940.55

5. TEST METHODOLOGY

TIA-603-E dated March 2016 entitled “Land Mobile FM or PM Communications Equipment Measurement and Performance Standards” were used in the measurement.

5.1 EUT CONFIGURATION

The EUT configuration for testing is installed on RF field strength measurement to meet the Commissions requirement and operating in a manner that intends to maximize its emission characteristics in a continuous normal application.

5.2 EUT EXERCISE

The EUT was operated in the engineering mode to fix the Tx frequency that was for the purpose of the measurements. According to its specifications, the EUT must comply with the requirements of the FCC Rules Part 2, Part 90 and Part24D.

5.3 GENERAL TEST PROCEDURES

Radiated Emissions

Radiated emission measurements are performed in the Fully-anechoic chamber. The equipment under test is placed on a non-conductive table 3-meters away from the receive antenna in accordance with ANSI/TIA-603-E-2016. The turntable is rotated through 360 degrees, and the receiving antenna scans in order to determine the level of the maximized emission. The level and position of the maximized emission is recorded with the spectrum analyzer using a positive peak detector.

A half wave dipole is then substituted in place of the EUT. For emissions above 1GHz, a horn antenna is substituted in place of the EUT. The substitute antenna is driven by a signal generator and the previously recorded signal was duplicated.

The power is calculated by the following formula;

$$P_{d(\text{dBm})} = P_{g(\text{dBm})} - \text{cable loss (dB)} + \text{antenna gain (dB)}$$

Where: P_d is the dipole equivalent power and P_g is the generator output power into the substitution antenna.

The maximum EIRP is calculated by adding the forward power to the calibrated source plus its appropriate gain value. These steps are repeated with the receiving antenna in both vertical and horizontal polarization. the difference between the gain of the horn and an isotropic antenna are taken into consideration

5.4 DESCRIPTION OF TEST MODES

The EUT has been tested under operating condition.

Test program used to control the EUT for staying in continuous transmitting is programmed.

6. INSTRUMENT CALIBRATION

The measuring equipment, which was utilized in performing the tests documented herein, has been calibrated in accordance with the manufacturer's recommendations for utilizing calibration equipments, which is traceable to recognized national standards.

7. FACILITIES AND ACCREDITATIONS

7.1 FACILITIES

The SAC(Semi-Anechoic Chamber) and conducted measurement facility used to collect the radiated data are located at the 74, Seoicheon-ro 578beon-gil, Majang-myeon, Icheon-si, Gyeonggi-do, 17383, Rep. of KOREA. The site is constructed in conformance with the requirements of ANSI C63.4. (Version :2014) and CISPR Publication 22.

Detailed description of test facility was submitted to the Commission and accepted dated April 02, 2018 (Registration Number: KR0032).

For ISED, test facility was accepted dated December 20, 2016(Registration Number: 5944A-3)

7.2 EQUIPMENT

Radiated emissions are measured with one or more of the following types of Linearly polarized antennas: tuned dipole, bi-conical, log periodic, bi-log, and/or ridged waveguide, horn. Spectrum analyzers with pre-selectors and quasi-peak detectors are used to perform radiated measurements.

Conducted emissions are measured with Line Impedance Stabilization Networks and EMI Test Receivers. Calibrated wideband preamplifiers, coaxial cables, and coaxial attenuators are also used for making measurements.

All receiving equipment conforms to CISPR Publication 16-1, "Radio Interference Measuring Apparatus and Measurement Methods."

8. WORST CASE CONFIGURATION AND MODE

Radiated test

1. EUT Axis : Y
2. NX-3400-K3 & Additional Models were tested and the worst case results are reported.
(Worst case : NX-3400-K3)
3. All modes of operation were investigated and the worst case configuration results are reported.
 - Mode : Stand alone (High Power/ Low Power)
 - Stand alone + Microphone (High Power/ Low Power)
 - Stand alone + Accessories (High Power/ Low Power)
 - Stand alone + Microphone + Accessories (High Power/ Low Power)
 - Worstcase : Stand alone + Microphone (High Power)
4. All type of battery were investigated and the worst case configuration results are reported.
 - Battery type : KNB-79LC, KNB-78L KBP-5 KNB-57L KNB-56N KNB-55L
 - Worstcase : KNB-79LC

Conducted test

1. NX-3400-K3 & Additional Models were tested and the worst case results are reported.
(Worst case : NX-3400-K3)

9. SUMMARY TEST OF RESULTS

Frequency Range: 806-824 MHz, 851-869 MHz

Test Description	FCC Part Section(s)	IC Part Section(s)	FCC Limit	IC Limit
Carrier Output Power	§2.1046 §90.205 §90.635	RSS-Gen, RSS-119	< 100 W	< 30 W
Unwanted Emissions	§2.1051 §90.210	RSS-119	43 + 10 log (P)dB	6.25 kHz: 55+ 10 log (P)dB 12.5 kHz: 50 + 10 log (P)dB 25 kHz: 43 + 10 log (P)dB
99% Bandwidth	-	RSS-119	6.25 kHz: 6 kHz 12.5 kHz: 11.25kHz 25 kHz: 20 kHz	6.25 kHz: 6 kHz 12.5 kHz: 11.25kHz 25 kHz: 20 kHz
Carrier Frequency Stability	§2.1055 §90.213(a)	RSS-Gen, RSS-119	809MHz-824MHz= 2.5 ppm 854MHz-869MHz= 2.5 ppm 806MHz-809MHz= 1.5 ppm 851MHz-854MHz= 1.5 ppm	6.25 kHz = 0.4 ppm 12.5 kHz = 1.5 ppm 25 kHz = 2.5 ppm
Audio Frequency Response	§2.1047(a)	-	Varies	Varies
Audio Low Pass Filter	§2.1047(a)	-	Varies	Varies
Modulation Limiting	§2.1047(b)	-	12.5 kHz = 2.5 kHz 25 kHz = 5 kHz	12.5 kHz = 2.5 kHz 25 kHz = 5 kHz
Emission Mask	§2.1049(c)(1), §90.210, §90.691	RSS-Gen, RSS-119	Emission Mask B, EA	Emission Mask B, D, E
Field Strength of Spurious Radiation	§2.1053, §90.210	RSS-119	43 + 10 log (P)dB	6.25 kHz: 55+ 10 log (P)dB 12.5 kHz: 50 + 10 log (P)dB 25 kHz: 43 + 10 log (P)dB

Receiver Spurious Emissions	-	RSS-Gen, RSS-119	-	<u>See Note1</u>
Necessary Bandwidth	§2.202	-	-	-

Frequency Range: 896-901 MHz, 935-940 MHz

Test Description	FCC Part Section(s)	IC Part Section(s)	FCC Limit	IC Limit
Carrier Output Power	§2.1046 §90.205 §90.635	RSS-Gen, RSS-119	< 100 W	< 60 W
Unwanted Emissions	§2.1051 §90.210	RSS-119	43 + 10 log (P)dB	43 + 10 log (P)dB
99% Bandwidth	-	RSS-119	< 13.6kHz	< 13.6kHz
Carrier Frequency Stability	§2.1055 §90.213(a)	RSS-Gen, RSS-119	1.5 ppm	1.5 ppm
Audio Frequency Response	§2.1047(a)	-	Varies	Varies
Audio Low Pass Filter	§2.1047(a)	-	Varies	Varies
Modulation Limiting	§2.1047(b)	-	2.5 kHz	2.5 kHz
Emission Mask	§2.1049(c)(1), §90.210, §90.691	RSS-Gen, RSS-119	Emission Mask I	Emission Mask I
Field Strength of Spurious Radiation	§2.1053, §90.210	RSS-119	43 + 10 log (P)dB	43 + 10 log (P)dB
Receiver Spurious Emissions	-	RSS-Gen, RSS-119	-	<u>See Note1</u>
Necessary Bandwidth	§2.202	-	-	-

Frequency Range: 901-902 MHz, 940-941 MHz

Test Description	FCC Part Section(s)	IC Part Section(s)	FCC Limit	IC Limit
Carrier Output Power	§2.1046, §24.132	RSS-134 Issue 2 (4.3)	7 watts e.r.p.	7 watts e.r.p.
Unwanted Emissions	§2.1051	RSS-134 Issue 2 (4.4.2)	43 + 10 Log 10 (P)	43 + 10 Log 10 (P)
99% Bandwidth	-	RSS-134 Issue 2 (4.1)		Authorized bandwidth. - 12.5kHz : 10kHz - 50kHz : 45kHz
Carrier Frequency Stability	§2.1055, §24.135 §2.1047(a)	RSS-134 Issue 2 (4.5)	1.0 ppm	1.0 ppm
Audio Frequency Response	§2.1047(a)	-	Varies	Varies
Audio Low Pass Filter	§2.1047(b)	-	Varies	Varies
Modulation Limiting	§2.1049(c)(1), §24.131, §24.133(a)(2)	RSS-134 Issue 2 (4.4.2)	2.5 kHz	2.5 kHz
Emission Mask	§2.1053, §24.133(a)(2)	RSS-134 Issue 2 (4.4.2)	1) For fd up to and including 20 kHz : at least $116 \log_{10}((fd+5)/3.05)$ dB, or $50+10 \log_{10} (P)$ dB, or 70 dB, whichever is the lesser attenuation 2) For fd of more than 20 kHz : $43 + 10 \text{ Log } 10 (P)$	
Field Strength of Spurious Radiation	-	RSS-Gen Issue 5 (7)	$43 + 10 \text{ Log } 10 (P)$	$43 + 10 \text{ Log } 10 (P)$
Receiver Spurious Emissions	§2.202	-		
Necessary Bandwidth	§2.1046, §24.132	RSS-134 Issue 2 (4.3)		

Note:

1. Receiver Spurious Emissions Limit :

Frequency (MHz)	Field Strength ($\mu\text{v/m}$ at 3 meters)
30 – 88	100
88 - 216	150
216 – 960	200
Above 960	500

10. TEST RESULT

10.1 Carrier Output Power

Definition

The conducted carrier power output rating for a transmitter is the power available at the output terminals of the transmitter when the output terminals are connected to the standard transmitter load.

TEST CONFIGURATION

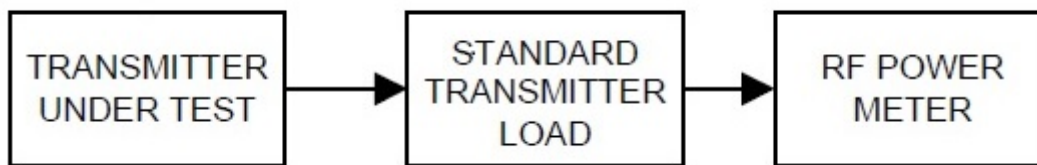

TEST PROCEDURE

According to 2.2.1 in TIA-603-E Standard.

- a) Connect the equipment as illustrated.
- b) Measure the transmitter output power during the defined duty cycle(see 1.3.2).
Correct for all losses in the RF path.
- c) The value recorded in step b) is the conducted carrier output power rating.

TEST RESULTS

Type of Emission	Channel Bandwidth (KHz)	Test Frequency (MHz)	Carrier Output Power			
			High Power		Low Power	
			dBm	W	dBm	W
16K0F3E	25	806.05	34.527	2.836	29.981	0.996
		851.05	34.757	2.990	30.347	1.083
		868.95	34.663	2.926	30.286	1.068
14K0F3E	25	806.05	34.540	2.844	29.977	0.995
		851.05	34.762	2.994	30.337	1.081
		868.95	34.659	2.923	30.295	1.070
11K0F3E	12.5	806.05	34.517	2.829	29.986	0.997
		851.05	34.748	2.984	30.373	1.090
		868.95	34.653	2.919	30.315	1.075
		896.05	34.521	2.832	30.068	1.016
		900.95	34.519	2.830	30.043	1.010
		939.95	34.597	2.882	30.149	1.035
8K30F1E, 8K30F1D, 8K30F7W	12.5	806.05	34.570	2.864	30.007	1.002
		851.05	34.782	3.008	30.379	1.091
		868.95	34.690	2.945	30.317	1.076
		896.05	34.471	2.800	30.086	1.020
		900.95	34.470	2.799	30.061	1.014
		939.95	34.556	2.855	30.159	1.037
7K60FXE, 7K60FXD	12.5	806.05	34.546	2.848	29.990	0.998
		851.05	34.770	2.999	30.371	1.089
		868.95	34.687	2.942	30.321	1.077
		896.05	34.546	2.848	30.061	1.014
		900.95	34.540	2.844	30.031	1.007
		939.95	34.637	2.909	30.153	1.036

Type of Emission	Channel Bandwidth (KHz)	Test Frequency (MHz)	Carrier Output Power			
			High Power		Low Power	
			dBm	W	dBm	W
4K00F1E, 4K00F1D, 4K00F7W	6.25	806.05	34.538	2.843	29.954	0.990
		851.05	34.764	2.995	30.355	1.085
		868.95	34.681	2.938	30.289	1.069
		896.05	34.509	2.824	30.076	1.018
		900.95	34.510	2.825	30.047	1.011
		939.95	34.583	2.872	30.166	1.039
4K00F2D	6.25	806.05	34.921	3.105	29.975	0.994
		851.05	34.965	3.137	30.340	1.081
		868.95	35.005	3.166	30.297	1.071
		896.05	34.975	3.144	30.080	1.019
		900.95	34.997	3.160	30.062	1.014
		939.95	35.138	3.264	30.156	1.037

Type of Emission	Channel Bandwidth (KHz)	Test Frequency (MHz)	ERP			
			High Power		Low Power	
			dBm	W	dBm	W
11K0F3E	50	901.55	34.669	2.930	30.064	1.015
		940.55	34.711	2.958	30.192	1.045
8K30F1E, 8K30F1D, 8K30F7W	50	901.55	34.762	2.993	30.046	1.011
		940.55	34.968	3.139	29.906	0.979
7K60FXE, 7K60FXD	50	901.55	34.609	2.890	30.321	1.077
		940.55	34.556	2.855	30.608	1.150
4K00F1E, 4K00F1D, 4K00F7W	12.5	901.55	34.390	2.748	30.042	1.010
		940.55	34.572	2.866	29.937	0.986
4K00F2D	12.5	901.55	34.996	3.159	30.722	1.181
		940.55	34.480	2.805	30.129	1.030

Note:

ERP = Carrier Output Power + Peak Antenna gain

10.2 Carrier Frequency Stability

Definition

The carrier frequency stability is the ability of the transmitter to maintain an assigned carrier frequency.

TEST CONFIGURATION

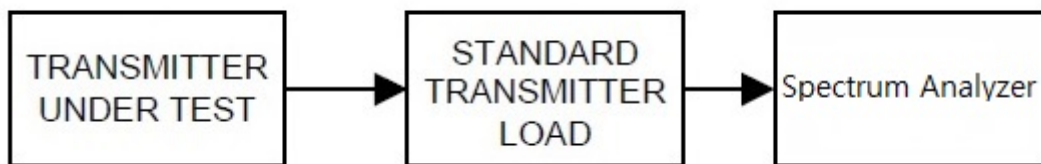

TEST PROCEDURE

According to 2.2.2 in TIA-603-E Standard.

- a) Connect the equipment as illustrated.
- b) Operate the equipment in standby conditions for 15 minutes before proceeding.
- c) Record the carrier frequency of the transmitter as MCF_{MHz}
- d) Calculate the ppm frequency error by the following:

$$\text{ppm error} = ((MCF_{MHz} / ACF_{MHz}) - 1) * 10^6$$

where

MCF_{MHz} is the Measured Carrier Frequency in MHz

ACF_{MHz} is the Assigned Carrier Frequency in MHz

- e) The value recorded in step d) is the carrier frequency stability.

Note

All type of emission were investigated and the worst case configuration results are reported.

(Worst case : 11K0F3E)

TEST RESULTS

(1) Frequency Stability (Temperature Variation)

806.05 MHz (High Power, FCC)

Temperature (Degree C)	Frequency (MHz)	Frequency stability (ppm)
-30	806.050000522	0.000647
-20	806.050016973	0.021056
-10	806.050004749	0.005891
0	806.050014479	0.017962
10	806.049996789	-0.003984
20	806.049997520	-0.003077
30	806.049968943	-0.038530
40	806.049972035	-0.034694
50	806.049996933	-0.003804

806.05 MHz (High Power, IC)

Temp. ()	Frequency (Hz)	Frequency Error (Hz)	Frequency stability (ppm)
+20(Ref)	806.049997520	0.0000000	0.000
-30	806.050000522	0.0000030	0.004
-20	806.050016973	0.0000195	0.024
-10	806.050004749	0.0000072	0.009
0	806.050014479	0.0000170	0.021
+10	806.049996789	-0.0000007	-0.001
+30	806.049968943	-0.0000286	-0.035
+40	806.049972035	-0.0000255	-0.032
+50	806.049996933	-0.0000006	-0.001

851.05 MHz (High Power, FCC)

Temperature (Degree C)	Frequency (MHz)	Frequency stability (ppm)
-30	851.050015546	0.018266
-20	851.049968475	-0.037043
-10	851.049972624	-0.032167
0	851.049972719	-0.032055
10	851.049981672	-0.021536
20	851.049995978	-0.004726
30	851.049987329	-0.014888
40	851.049966346	-0.039544
50	851.049975985	-0.028218

851.05 MHz (High Power, IC)

Temp. ()	Frequency (Hz)	Frequency Error (Hz)	Frequency stability (ppm)
+20(Ref)	851.049995978	0.0000000	0.000
-30	851.050015546	0.0000196	0.023
-20	851.049968475	-0.0000275	-0.032
-10	851.049972624	-0.0000234	-0.027
0	851.049972719	-0.0000233	-0.027
+10	851.049981672	-0.0000143	-0.017
+30	851.049987329	-0.0000086	-0.010
+40	851.049966346	-0.0000296	-0.035
+50	851.049975985	-0.0000200	-0.023

868.95 MHz (High Power, FCC)

Temperature (Degree C)	Frequency (MHz)	Frequency stability (ppm)
-30	868.949996204	-0.004369
-20	868.949962239	-0.043456
-10	868.949971643	-0.032633
0	868.949976503	-0.027040
10	868.950015960	0.018367
20	868.949990451	-0.010989
30	868.949977672	-0.025695
40	868.949985178	-0.017057
50	868.949969417	-0.035195

868.95 MHz (High Power, IC)

Temp. ()	Frequency (Hz)	Frequency Error (Hz)	Frequency stability (ppm)
+20(Ref)	868.949990451	0.0000000	0.000
-30	868.949996204	0.0000058	0.007
-20	868.949962239	-0.0000282	-0.032
-10	868.949971643	-0.0000188	-0.022
0	868.949976503	-0.0000139	-0.016
+10	868.950015960	0.0000255	0.029
+30	868.949977672	-0.0000128	-0.015
+40	868.949985178	-0.0000053	-0.006
+50	868.949969417	-0.0000210	-0.024

806.05 MHz (Low Power, FCC)

Temperature (Degree C)	Frequency (MHz)	Frequency stability (ppm)
-30	806.049989271	-0.013311
-20	806.049971393	-0.035490
-10	806.049969822	-0.037439
0	806.049977817	-0.027521
10	806.049950127	-0.061873
20	806.049965822	-0.042402
30	806.049968401	-0.039202
40	806.049946089	-0.066883
50	806.049973598	-0.032755

806.05 MHz (Low Power, IC)

Temp. ()	Frequency (Hz)	Frequency Error (Hz)	Frequency stability (ppm)
+20(Ref)	806.049965822	0.0000000	0.000
-30	806.049989271	0.0000234	0.029
-20	806.049971393	0.0000056	0.007
-10	806.049969822	0.0000040	0.005
0	806.049977817	0.0000120	0.015
+10	806.049950127	-0.0000157	-0.019
+30	806.049968401	0.0000026	0.003
+40	806.049946089	-0.0000197	-0.024
+50	806.049973598	0.0000078	0.010

851.05 MHz (Low Power, FCC)

Temperature (Degree C)	Frequency (MHz)	Frequency stability (ppm)
-30	851.049986316	-0.016079
-20	851.049983888	-0.018932
-10	851.049981023	-0.022298
0	851.049958609	-0.048636
10	851.049980862	-0.022487
20	851.049958727	-0.048496
30	851.049982688	-0.020341
40	851.049948859	-0.060092
50	851.049946945	-0.062341

851.05 MHz (Low Power, IC)

Temp. ()	Frequency (Hz)	Frequency Error (Hz)	Frequency stability (ppm)
+20(Ref)	851.049958727	0.0000000	0.000
-30	851.049986316	0.0000276	0.032
-20	851.049983888	0.0000252	0.030
-10	851.049981023	0.0000223	0.026
0	851.049958609	-0.0000001	0.000
+10	851.049980862	0.0000221	0.026
+30	851.049982688	0.0000240	0.028
+40	851.049948859	-0.0000099	-0.012
+50	851.049946945	-0.0000118	-0.014

868.95 MHz (Low Power, FCC)

Temperature (Degree C)	Frequency (MHz)	Frequency stability (ppm)
-30	868.949966076	-0.039040
-20	868.949987250	-0.014673
-10	868.949974731	-0.029080
0	868.949975738	-0.027921
10	868.949985829	-0.016308
20	868.949957550	-0.048852
30	868.949942426	-0.066257
40	868.949951949	-0.055298
50	868.949939244	-0.069919

868.95 MHz (Low Power, IC)

Temp. ()	Frequency (Hz)	Frequency Error (Hz)	Frequency stability (ppm)
+20(Ref)	868.949957550	0.0000000	0.000
-30	868.949966076	0.0000085	0.010
-20	868.949987250	0.0000297	0.034
-10	868.949974731	0.0000172	0.020
0	868.949975738	0.0000182	0.021
+10	868.949985829	0.0000283	0.033
+30	868.949942426	-0.0000151	-0.017
+40	868.949951949	-0.0000056	-0.006
+50	868.949939244	-0.0000183	-0.021

(2) Frequency Stability (Voltage Variation)

806.05 MHz (High Power)

Temperature (Degree C)	Deviation (%)	Voltage (V)	Frequency (MHz)	Frequency stability (ppm)
20	85	6.38	806.049999631	-0.000458
20	100	7.50	806.049997012	-0.003707
20	115	8.63	806.049996368	-0.004505

851.05 MHz (High Power)

Temperature (Degree C)	Deviation (%)	Voltage (V)	Frequency (MHz)	Frequency stability (ppm)
20	85	6.38	851.049997287	-0.003188
20	100	7.50	851.049993715	-0.007385
20	115	8.63	851.049993326	-0.007842

868.95 MHz (High Power)

Temperature (Degree C)	Deviation (%)	Voltage (V)	Frequency (MHz)	Frequency stability (ppm)
20	85	6.38	868.949992092	-0.009101
20	100	7.50	868.949988431	-0.013314
20	115	8.63	868.949987744	-0.014105

806.05 MHz (Low Power)

Temperature (Degree C)	Deviation (%)	Voltage (V)	Frequency (MHz)	Frequency stability (ppm)
20	85	6.38	806.049966428	-0.041650
20	100	7.50	806.049963375	-0.045437
20	115	8.63	806.049962613	-0.046382

851.05 MHz (Low Power)

Temperature (Degree C)	Deviation (%)	Voltage (V)	Frequency (MHz)	Frequency stability (ppm)
20	85	6.38	851.049959610	-0.047459
20	100	7.50	851.049957379	-0.050080
20	115	8.63	851.049955983	-0.051721

868.95 MHz (Low Power)

Temperature (Degree C)	Deviation (%)	Voltage (V)	Frequency (MHz)	Frequency stability (ppm)
20	85	6.38	868.949958803	-0.047410
20	100	7.50	868.949956738	-0.049786
20	115	8.63	868.949955456	-0.051261

TEST RESULTS

(1) Frequency Stability (Temperature Variation)

896.05 MHz (High Power, FCC)

Temperature (Degree C)	Frequency (MHz)	Frequency stability (ppm)
-30	896.050033899	0.037832
-20	896.050029898	0.033367
-10	896.050062830	0.070118
0	896.050036850	0.041125
10	896.050046744	0.052167
20	896.050038231	0.042666
30	896.050044776	0.049970
40	896.050040526	0.045227
50	896.050015989	0.017844

896.05 MHz (High Power, IC)

Temp. ()	Frequency (Hz)	Frequency Error (Hz)	Frequency stability (ppm)
+20(Ref)	896.050038231	0.0000000	0.000
-30	896.050033899	-0.0000043	-0.005
-20	896.050029898	-0.0000083	-0.009
-10	896.050062830	0.0000246	0.027
0	896.050036850	-0.0000014	-0.002
+10	896.050046744	0.0000085	0.010
+30	896.050044776	0.0000065	0.007
+40	896.050040526	0.0000023	0.003
+50	896.050015989	-0.0000222	-0.025

900.95 MHz (High Power, FCC)

Temperature (Degree C)	Frequency (MHz)	Frequency stability (ppm)
-30	900.950061451	0.068206
-20	900.950030312	0.033644
-10	900.950030876	0.034271
0	900.950060862	0.067553
10	900.950036720	0.040757
20	900.950041149	0.045673
30	900.950011502	0.012766
40	900.950035977	0.039932
50	900.950066365	0.073661

900.95 MHz (High Power, IC)

Temp. ()	Frequency (Hz)	Frequency Error (Hz)	Frequency stability (ppm)
+20(Ref)	900.950041149	0.0000000	0.000
-30	900.950061451	0.0000203	0.023
-20	900.950030312	-0.0000108	-0.012
-10	900.950030876	-0.0000103	-0.011
0	900.950060862	0.0000197	0.022
+10	900.950036720	-0.0000044	-0.005
+30	900.950011502	-0.0000296	-0.033
+40	900.950035977	-0.0000052	-0.006
+50	900.950066365	0.0000252	0.028

939.95 MHz (High Power, FCC)

Temperature (Degree C)	Frequency (MHz)	Frequency stability (ppm)
-30	939.950042658	0.045383
-20	939.950047339	0.050363
-10	939.950038088	0.040522
0	939.950058372	0.062101
10	939.950041414	0.044060
20	939.950032691	0.034780
30	939.950010884	0.011580
40	939.950009874	0.010505
50	939.950017277	0.018381

939.95 MHz (High Power, IC)

Temp. ()	Frequency (Hz)	Frequency Error (Hz)	Frequency stability (ppm)
+20(Ref)	939.950032691	0.0000000	0.000
-30	939.950042658	0.0000100	0.011
-20	939.950047339	0.0000146	0.016
-10	939.950038088	0.0000054	0.006
0	939.950058372	0.0000257	0.027
+10	939.950041414	0.0000087	0.009
+30	939.950010884	-0.0000218	-0.023
+40	939.950009874	-0.0000228	-0.024
+50	939.950017277	-0.0000154	-0.016

896.05 MHz (Low Power, FCC)

Temperature (Degree C)	Frequency (MHz)	Frequency stability (ppm)
-30	896.049978952	-0.023490
-20	896.049978638	-0.023840
-10	896.050001252	0.001397
0	896.050021629	0.024138
10	896.049974438	-0.028528
20	896.049995025	-0.005553
30	896.050005672	0.006330
40	896.049980653	-0.021591
50	896.050022572	0.025190

896.05 MHz (Low Power, IC)

Temp. ()	Frequency (Hz)	Frequency Error (Hz)	Frequency stability (ppm)
+20(Ref)	896.049995025	0.0000000	0.000
-30	896.049978952	-0.0000161	-0.018
-20	896.049978638	-0.0000164	-0.018
-10	896.050001252	0.0000062	0.007
0	896.050021629	0.0000266	0.030
+10	896.049974438	-0.0000206	-0.023
+30	896.050005672	0.0000106	0.012
+40	896.049980653	-0.0000144	-0.016
+50	896.050022572	0.0000275	0.031

900.95 MHz (Low Power, FCC)

Temperature (Degree C)	Frequency (MHz)	Frequency stability (ppm)
-30	900.950002049	0.002274
-20	900.949980825	-0.021283
-10	900.949999993	-0.000008
0	900.949969744	-0.033583
10	900.950010508	0.011663
20	900.949992872	-0.007911
30	900.949991241	-0.009722
40	900.950007727	0.008576
50	900.950007803	0.008661

900.95 MHz (Low Power, IC)

Temp. ()	Frequency (Hz)	Frequency Error (Hz)	Frequency stability (ppm)
+20(Ref)	900.949992872	0.0000000	0.000
-30	900.950002049	0.0000092	0.010
-20	900.949980825	-0.0000120	-0.013
-10	900.949999993	0.0000071	0.008
0	900.949969744	-0.0000231	-0.026
+10	900.950010508	0.0000176	0.020
+30	900.949991241	-0.0000016	-0.002
+40	900.950007727	0.0000149	0.016
+50	900.950007803	0.0000149	0.017

939.95 MHz (Low Power, FCC)

Temperature (Degree C)	Frequency (MHz)	Frequency stability (ppm)
-30	939.950019590	0.020842
-20	939.949991176	-0.009387
-10	939.950000886	0.000942
0	939.950008649	0.009201
10	939.949999361	-0.000680
20	939.949994919	-0.005405
30	939.949971108	-0.030738
40	939.949997245	-0.002931
50	939.949997245	-0.002931

939.95 MHz (Low Power, IC)

Temp. ()	Frequency (Hz)	Frequency Error (Hz)	Frequency stability (ppm)
+20(Ref)	939.949994919	0.0000000	0.000
-30	939.950019590	0.0000247	0.026
-20	939.949991176	-0.0000037	-0.004
-10	939.950000886	0.0000060	0.006
0	939.950008649	0.0000137	0.015
+10	939.949999361	0.0000044	0.005
+30	939.949971108	-0.0000238	-0.025
+40	939.949997245	0.0000023	0.002
+50	939.949997245	0.0000023	0.002

(2) Frequency Stability (Voltage Variation)

896.05 MHz (High Power)

Temperature (Degree C)	Deviation (%)	Voltage (V)	Frequency (MHz)	Frequency stability (ppm)
20	85	6.38	896.050039280	0.043837
20	100	7.50	896.050038466	0.042929
20	115	8.63	896.050036494	0.040727

900.95 MHz (High Power)

Temperature (Degree C)	Deviation (%)	Voltage (V)	Frequency (MHz)	Frequency stability (ppm)
20	85	6.38	900.950042637	0.047324
20	100	7.50	900.950038450	0.042678
20	115	8.63	900.950038260	0.042466

939.95 MHz (High Power)

Temperature (Degree C)	Deviation (%)	Voltage (V)	Frequency (MHz)	Frequency stability (ppm)
20	85	6.38	939.950033206	0.035327
20	100	7.50	939.950027778	0.029553
20	115	8.63	939.950028233	0.030037

896.05 MHz (Low Power)

Temperature (Degree C)	Deviation (%)	Voltage (V)	Frequency (MHz)	Frequency stability (ppm)
20	85	6.38	896.049995707	-0.004791
20	100	7.50	896.049992170	-0.008738
20	115	8.63	896.049991529	-0.009454

900.95 MHz (Low Power)

Temperature (Degree C)	Deviation (%)	Voltage (V)	Frequency (MHz)	Frequency stability (ppm)
20	85	6.38	900.949994112	-0.006536
20	100	7.50	900.949991474	-0.009463
20	115	8.63	900.949990211	-0.010866

939.95 MHz (Low Power)

Temperature (Degree C)	Deviation (%)	Voltage (V)	Frequency (MHz)	Frequency stability (ppm)
20	85	6.38	939.949995446	-0.004845
20	100	7.50	939.949992049	-0.008459
20	115	8.63	939.949991279	-0.009279

TEST RESULTS

(1) Frequency Stability (Temperature Variation)

901.55 MHz (High Power, FCC)

Temperature (Degree C)	Frequency (MHz)	Frequency stability (ppm)
-30	901.550031351	0.034774
-20	901.550024455	0.027125
-10	901.550067095	0.074422
0	901.550061914	0.068675
10	901.550052432	0.058157
20	901.550048393	0.053678
30	901.550070473	0.078169
40	901.550077158	0.085584
50	901.550038569	0.042781

901.55 MHz (High Power, IC)

Temp. ()	Frequency (Hz)	Frequency Error (Hz)	Frequency stability (ppm)
+20(Ref)	901.550048393	0.0000000	0.000
-30	901.550031351	-0.0000170	-0.019
-20	901.550024455	-0.0000239	-0.027
-10	901.550067095	0.0000187	0.021
0	901.550061914	0.0000135	0.015
+10	901.550052432	0.0000040	0.004
+30	901.550070473	0.0000221	0.024
+40	901.550077158	0.0000288	0.032
+50	901.550038569	-0.0000098	-0.011

940.55 MHz (High Power, FCC)

Temperature (Degree C)	Frequency (MHz)	Frequency stability (ppm)
-30	940.550065181	0.069301
-20	940.550075844	0.080638
-10	940.550076763	0.081615
0	940.550063678	0.067703
10	940.550056684	0.060267
20	940.550079818	0.084863
30	940.550101254	0.107654
40	940.550076955	0.081819
50	940.550052977	0.056326

940.55 MHz (High Power, IC)

Temp. ()	Frequency (Hz)	Frequency Error (Hz)	Frequency stability (ppm)
+20(Ref)	940.550079818	0.0000000	0.000
-30	940.550065181	-0.0000146	-0.016
-20	940.550075844	-0.0000040	-0.004
-10	940.550076763	-0.0000031	-0.003
0	940.550063678	-0.0000161	-0.017
+10	940.550056684	-0.0000231	-0.025
+30	940.550101254	0.0000214	0.023
+40	940.550076955	-0.0000029	-0.003
+50	940.550052977	-0.0000268	-0.029

901.55 MHz (Low Power, FCC)

Temperature (Degree C)	Frequency (MHz)	Frequency stability (ppm)
-30	901.550111619	0.123808
-20	901.550074076	0.082165
-10	901.550076165	0.084482
0	901.550072854	0.080810
10	901.550054209	0.060129
20	901.550083121	0.092198
30	901.550091077	0.101022
40	901.550058744	0.065158
50	901.550075064	0.083261

901.55 MHz (Low Power, IC)

Temp. ()	Frequency (Hz)	Frequency Error (Hz)	Frequency stability (ppm)
+20(Ref)	901.550083121	0.0000000	0.000
-30	901.550111619	0.0000285	0.032
-20	901.550074076	-0.0000090	-0.010
-10	901.550076165	-0.0000070	-0.008
0	901.550072854	-0.0000103	-0.011
+10	901.550054209	-0.0000289	-0.032
+30	901.550091077	0.0000080	0.009
+40	901.550058744	-0.0000244	-0.027
+50	901.550075064	-0.0000081	-0.009

940.55 MHz (Low Power, FCC)

Temperature (Degree C)	Frequency (MHz)	Frequency stability (ppm)
-30	940.550059363	0.063115
-20	940.550100800	0.107171
-10	940.550071058	0.075549
0	940.550105920	0.112615
10	940.550107989	0.114815
20	940.550079488	0.084512
30	940.550087438	0.092965
40	940.550106080	0.112785
50	940.550079029	0.084024

940.55 MHz (Low Power, IC)

Temp. ()	Frequency (Hz)	Frequency Error (Hz)	Frequency stability (ppm)
+20(Ref)	940.550079488	0.0000000	0.000
-30	940.550059363	-0.0000201	-0.021
-20	940.550100800	0.0000213	0.023
-10	940.550071058	-0.0000084	-0.009
0	940.550105920	0.0000264	0.028
+10	940.550107989	0.0000285	0.030
+30	940.550087438	0.0000079	0.008
+40	940.550106080	0.0000266	0.028
+50	940.550079029	-0.0000005	0.000

(2) Frequency Stability (Voltage Variation)

901.55 MHz (High Power)

Temperature (Degree C)	Deviation (%)	Voltage (V)	Frequency (MHz)	Frequency stability (ppm)
20	85	6.38	901.550051599	0.057233
20	100	7.50	901.550052007	0.057686
20	115	8.63	901.550049039	0.054394

940.55 MHz (High Power)

Temperature (Degree C)	Deviation (%)	Voltage (V)	Frequency (MHz)	Frequency stability (ppm)
20	85	6.38	940.550081260	0.086396
20	100	7.50	940.550081191	0.086323
20	115	8.63	940.550078473	0.083433

901.55 MHz (Low Power)

Temperature (Degree C)	Deviation (%)	Voltage (V)	Frequency (MHz)	Frequency stability (ppm)
20	85	6.38	901.550083916	0.093080
20	100	7.50	901.550079974	0.088707
20	115	8.63	901.550079485	0.088165

940.55 MHz (Low Power)

Temperature (Degree C)	Deviation (%)	Voltage (V)	Frequency (MHz)	Frequency stability (ppm)
20	85	6.38	940.550080350	0.085428
20	100	7.50	940.550077285	0.082170
20	115	8.63	940.550076157	0.080971

10.3 Occupied Bandwidth

Definition

The transmitter sideband spectrum denotes the sideband power produced at a discrete frequency separation from the carrier up to the test bandwidth (see TIA-603-E Section 1.3.4.4) due to all sources of unwanted noise within the transmitter in a modulated condition.

TEST CONFIGURATION

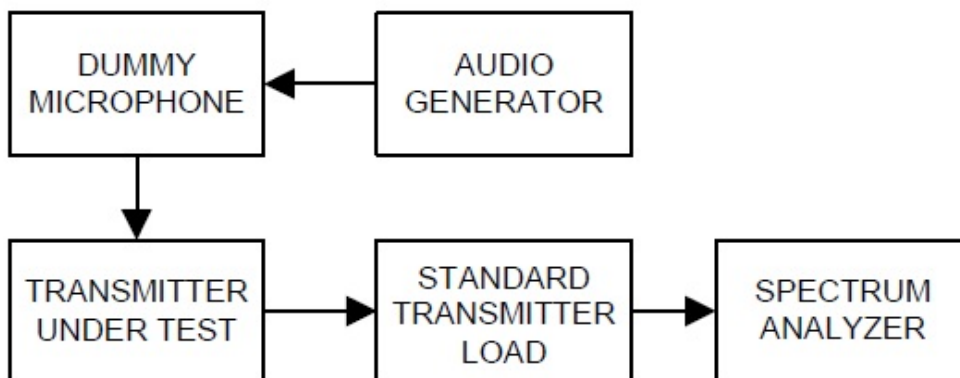

TEST PROCEDURE

According to TIA-603-E Section 2.2.11.2 / RSS-119 Section 5.5 / RSS-134 Section 4.1

- a) For EUT supporting audio modulation, the audio signal generator was adjusted to the frequency of maximum response and with output level set for +/- 2.5 kHz deviation (or 50 % modulation). (FM modulation).
- b) With level constant, the signal level was increased 16 dB.
- c) For EUT supporting digital modulation, the digital modulation mode was operated to its maximum extent.
- d) Adjust the spectrum analyzer for the following setting:
 - 1) RBW : 100Hz (Authorized Band 6 kHz),
100Hz (Authorized Band 11.25 kHz),
300Hz (Authorized Band 20 kHz)
 - 2) VBW : Video Bandwidth at least 10 times the resolution bandwidth.
 - 4) Sweep Speed : Sweep Speed slow enough to maintain measurement calibration.
 - 5) Sampling Time : 10 times
 - 6) Detector Mode = Positive Peak.
- e) The occupied Bandwidth was measured with the Spectrum Analyzer controls set as shown on the test results.

TEST RESULTS

Conducted 99% Bandwidth Measurements for 11K0F3E

11K0F3E Mode		Measured Bandwidth [kHz]	Setting	Limit [kHz]
Frequency [MHz]	Channel bandwidth			
806.05	12.5 kHz	9.887	High Power	11.25
851.05		9.913		
868.95		9.914		
896.05		9.898		
900.95		9.896		
939.95		9.920		
901.55	50 kHz	9.644	45	
940.55		9.685		
806.05	12.5 kHz	9.892	Low Power	11.25
851.05		9.918		
868.95		9.906		
896.05		9.905		
900.95		9.922		
939.95		9.926		
901.55	50 kHz	9.681	45	
940.55		9.701		

Conducted 99% Bandwidth Measurements for 14K0F3E

14K0F3E Mode		Measured Bandwidth [kHz]	Setting	Limit [kHz]
Frequency [MHz]	Channel bandwidth			
806.05	25.0 kHz	10.424	High Power	20.00
851.05		10.441		
868.95		10.438		
806.05	25.0 kHz	10.427	Low Power	20.00
851.05		10.443		
868.95		10.436		

Conducted 99% Bandwidth Measurements for 16K0F3E

16K0F3E Mode		Measured Bandwidth [kHz]	Setting	Limit [kHz]
Frequency [MHz]	Channel bandwidth			
806.05	25.0 kHz	14.611	High Power	20.00
851.05		14.688		
868.95		14.684		
806.05	25.0 kHz	14.607	Low Power	20.00
851.05		14.708		
868.95		14.682		

Conducted 99% Bandwidth Measurements for 8K30F1E, 8K30F1D, 8K30F7W

8K30F1E, 8K30F1D, 8K30F7W Mode		Measured Bandwidth [kHz]	Setting	Limit [kHz]
Frequency [MHz]	Channel bandwidth			
806.05	12.5 kHz	7.691	High Power	11.25
851.05		7.771		
868.95		7.723		
896.05		7.721		
900.95		7.787		
939.95		7.788		
901.55	50 kHz	8.266	High Power	45
940.55		8.110		
806.05	12.5 kHz	7.675	Low Power	11.25
851.05		7.754		
868.95		7.722		
896.05		7.708		
900.95		7.766		
939.95		7.806		
901.55	50 kHz	8.035	Low Power	45
940.55		7.748		

Conducted 99% Bandwidth Measurements for 7K60FXE, 7K60FXD

7K60FXE, 7K60FXD Mode		Measured Bandwidth [kHz]	Setting	Limit [kHz]
Frequency [MHz]	Channel bandwidth			
806.05	12.5 kHz	7.526	High Power	11.25
851.05		7.603		
868.95		7.588		
896.05		7.573		
900.95		7.625		
939.95		7.632		
901.55	50 kHz	7.730		45
940.55		7.785		
806.05	12.5 kHz	7.551	Low Power	11.25
851.05		7.621		
868.95		7.585		
896.05		7.575		
900.95		7.642		
939.95		7.656		
901.55	50 kHz	7.990		45
940.55		7.826		

Conducted 99% Bandwidth Measurements for 4K00F1E, 4K00F1D, 4K00F7W

4K00F1E, 4K00F1D, 4K00F7W Mode		Measured Bandwidth [kHz]	Setting	Limit [kHz]	
Frequency [MHz]	Channel bandwidth				
806.05	6.25 kHz	3.529	High Power	6.0	
851.05		3.564			
868.95		3.547			
896.05		3.529			
900.95		3.558			
939.95		3.532			
901.55	50 kHz	3.700		10	
940.55		3.585			
806.05	6.25 kHz	3.513		Low Power	6.0
851.05		3.554			
868.95		3.549			
896.05		3.550			
900.95		3.557			
939.95		3.567			
901.55	50 kHz	3.746	10		
940.55		3.581			

Conducted 99% Bandwidth Measurements for 4K00F2D

4K00F2D Mode		Measured Bandwidth [kHz]	Setting	Limit [kHz]	
Frequency [MHz]	Channel bandwidth				
806.05	6.25 kHz	3.281	High Power	6.0	
851.05		3.283			
868.95		3.281			
896.05		3.278			
900.95		3.282			
939.95		3.284			
901.55	50 kHz	3.508		10	
940.55		3.439			
806.05	6.25 kHz	3.274		Low Power	6.0
851.05		3.282			
868.95		3.280			
896.05		3.276			
900.95		3.279			
939.95		3.281			
901.55	50 kHz	3.465	10		
940.55		3.459			

Plots of 99% Bandwidth

(11K0F3E _ 806.05 MHz)_High

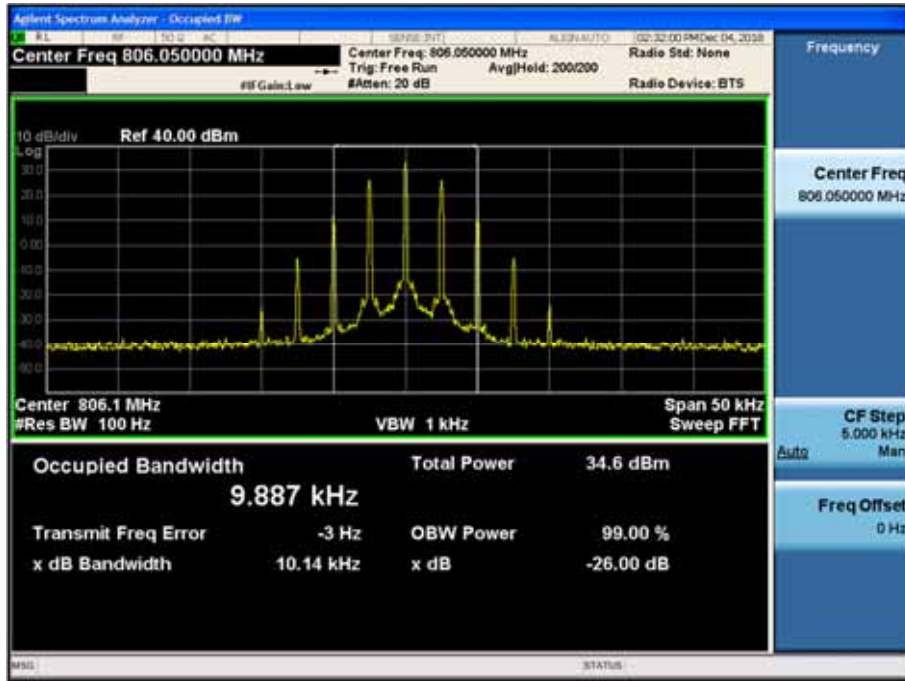

(11K0F3E _ 851.05 MHz)_High

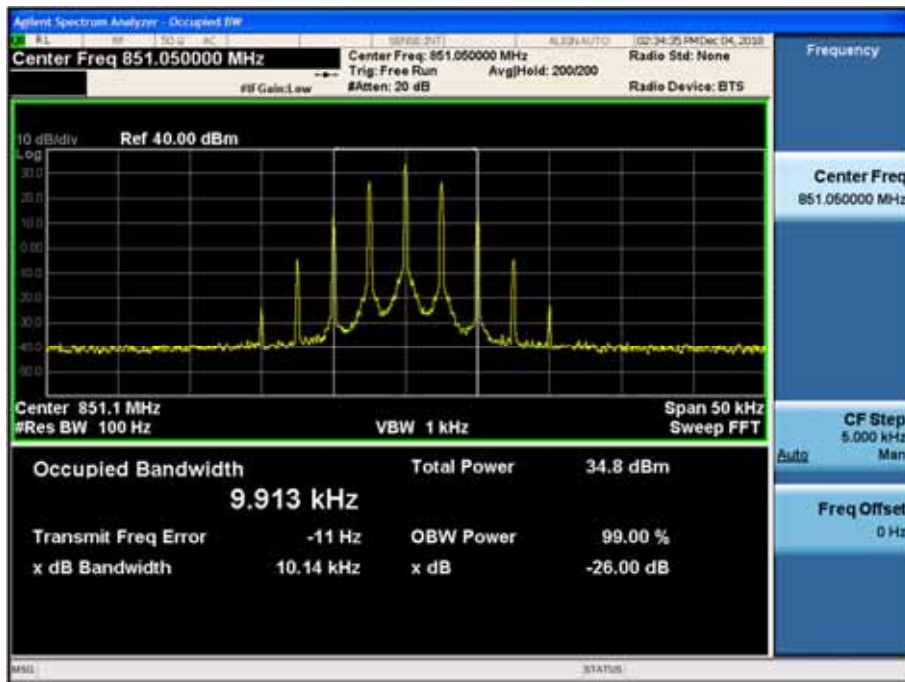

(11K0F3E _ 868.95 MHz)_High

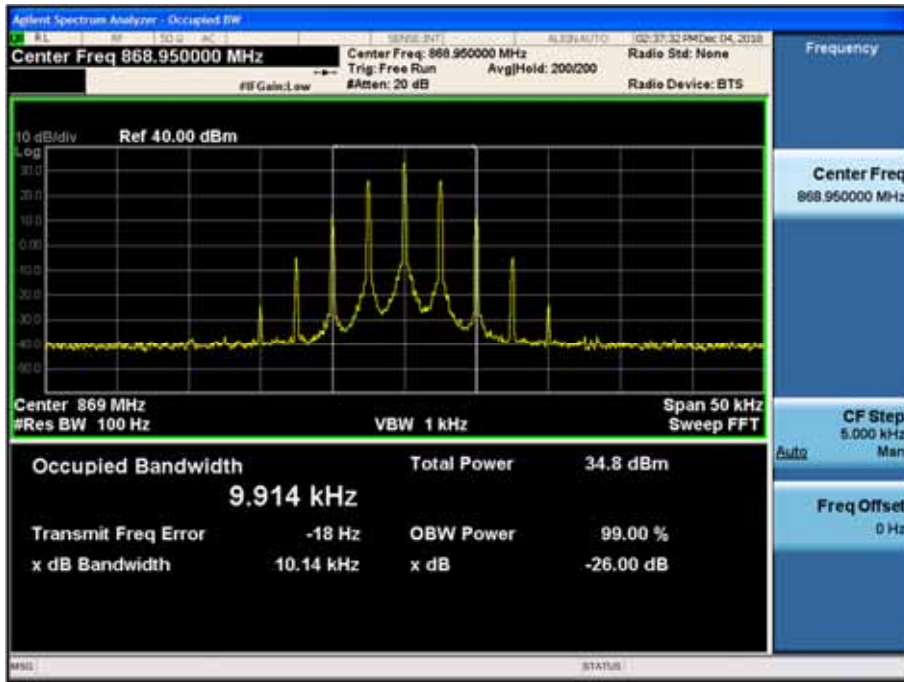

(11K0F3E _ 896.05 MHz)_High

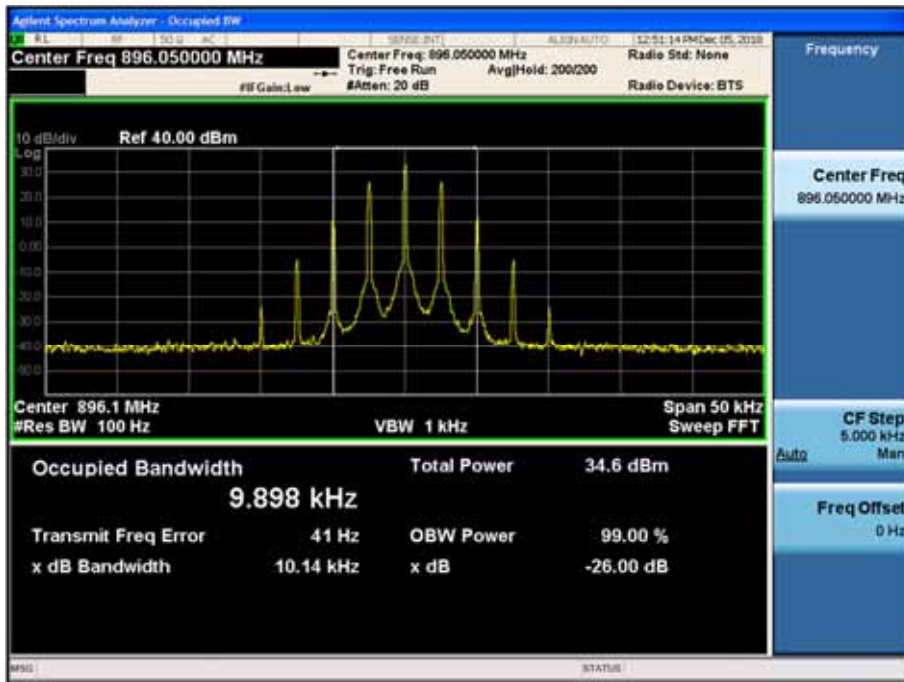

(11K0F3E _ 900.95 MHz)_ High

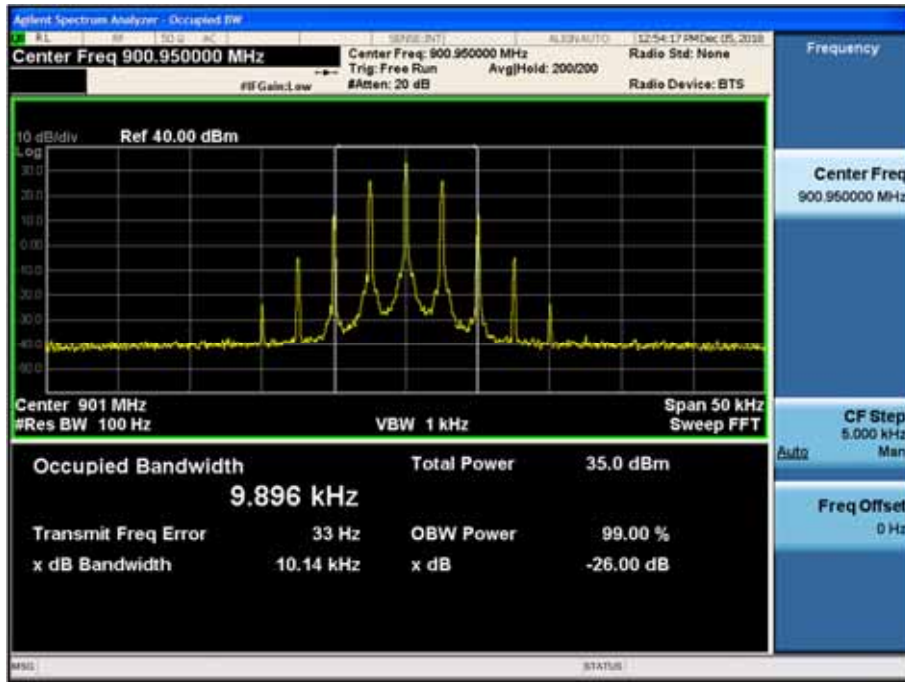

(11K0F3E _ 939.95 MHz)_ High

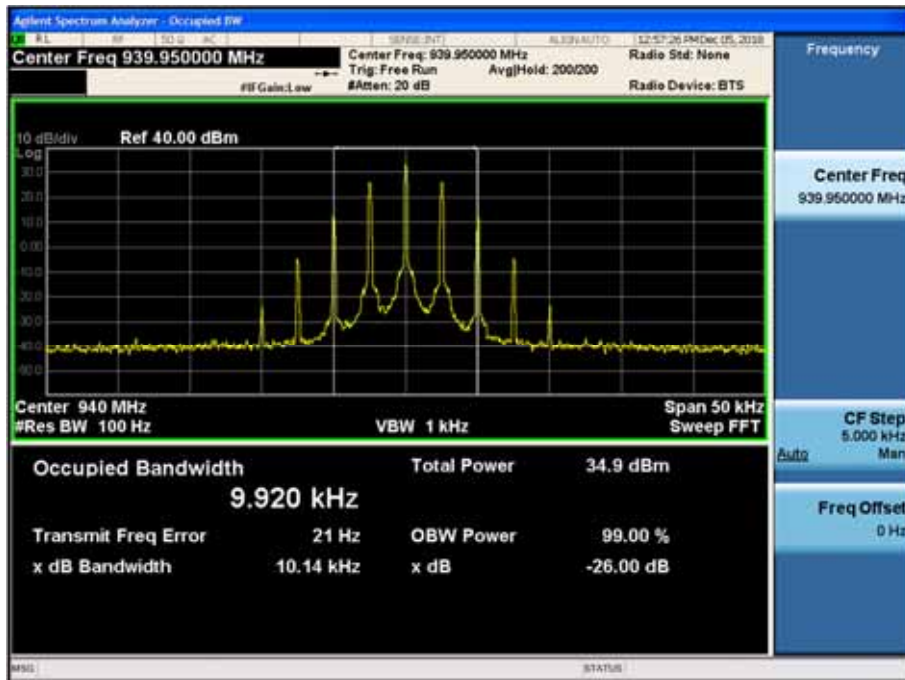

(11K0F3E _ 901.55 MHz)_ High

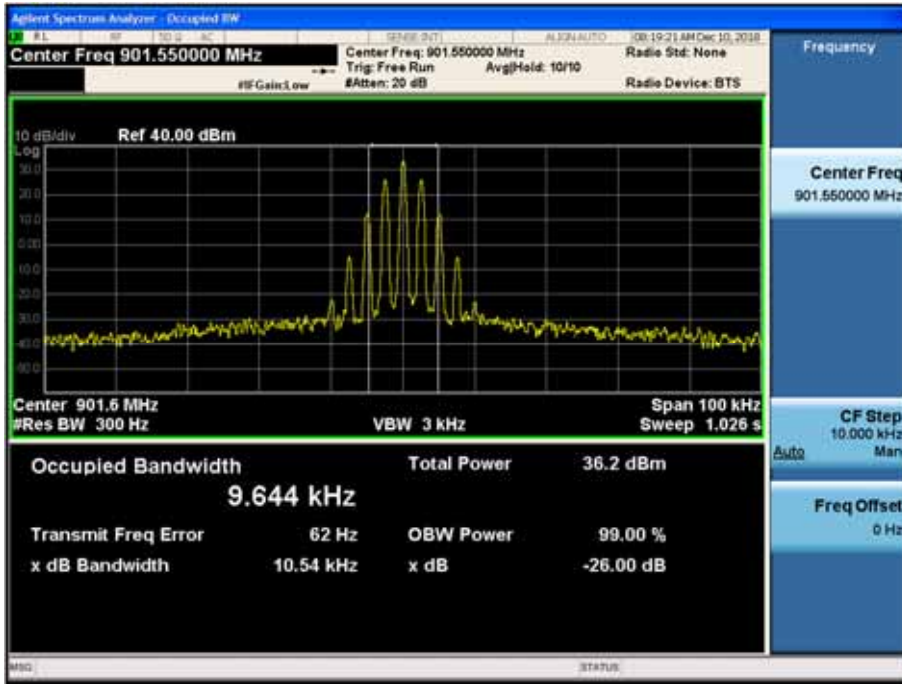

(11K0F3E _ 940.55 MHz)_ High

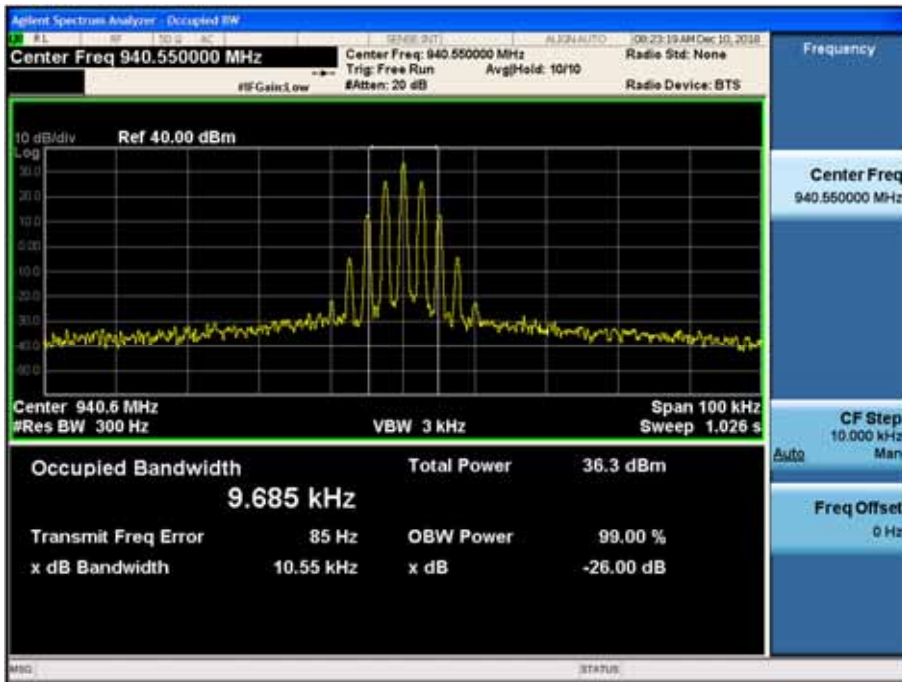

(11K0F3E _ 806.05 MHz)_ Low

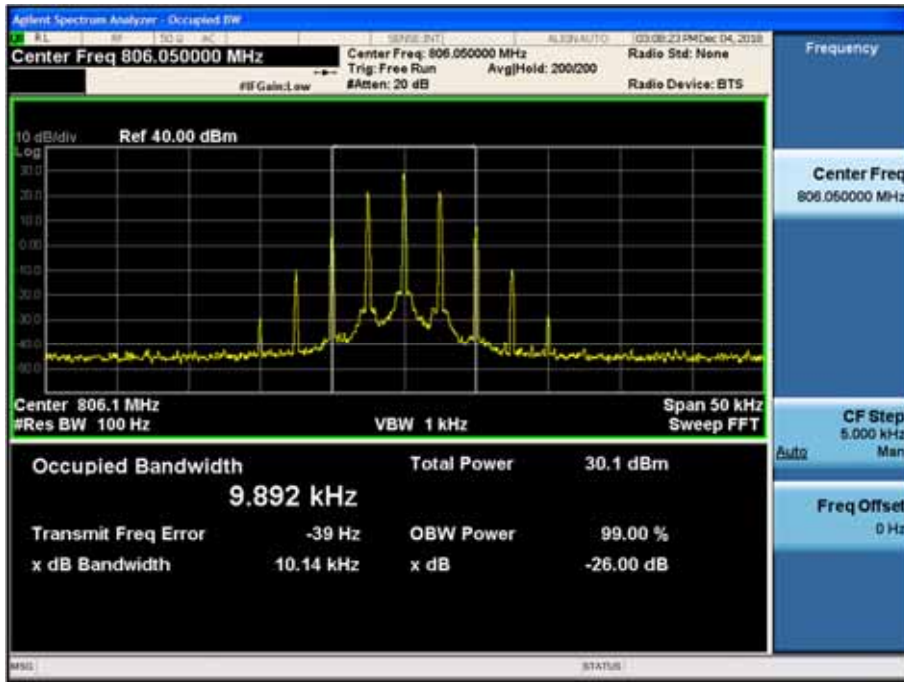

(11K0F3E _ 851.05 MHz)_ Low

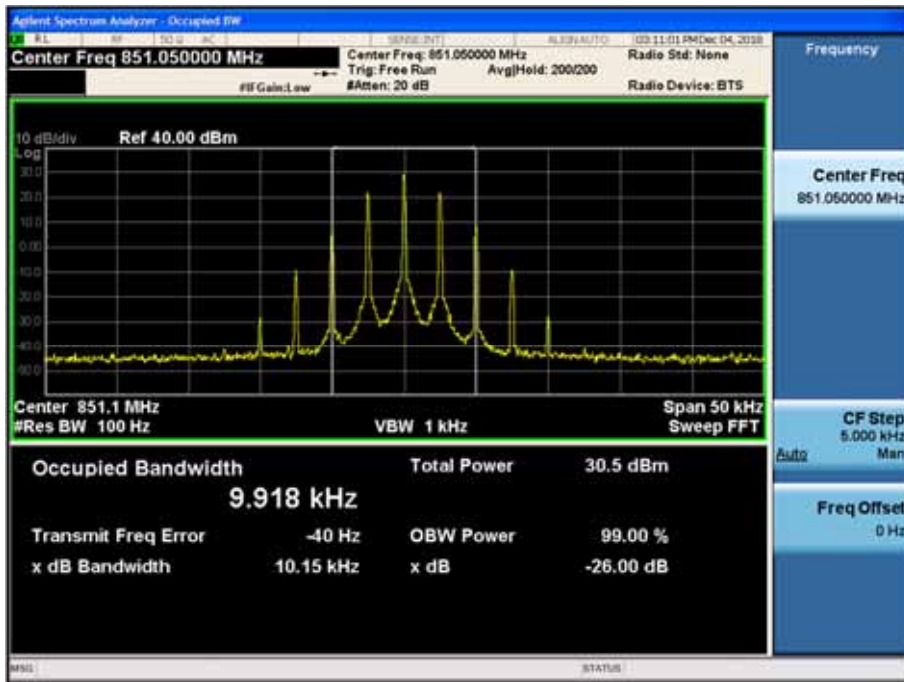

(11K0F3E _ 868.95 MHz)_ Low

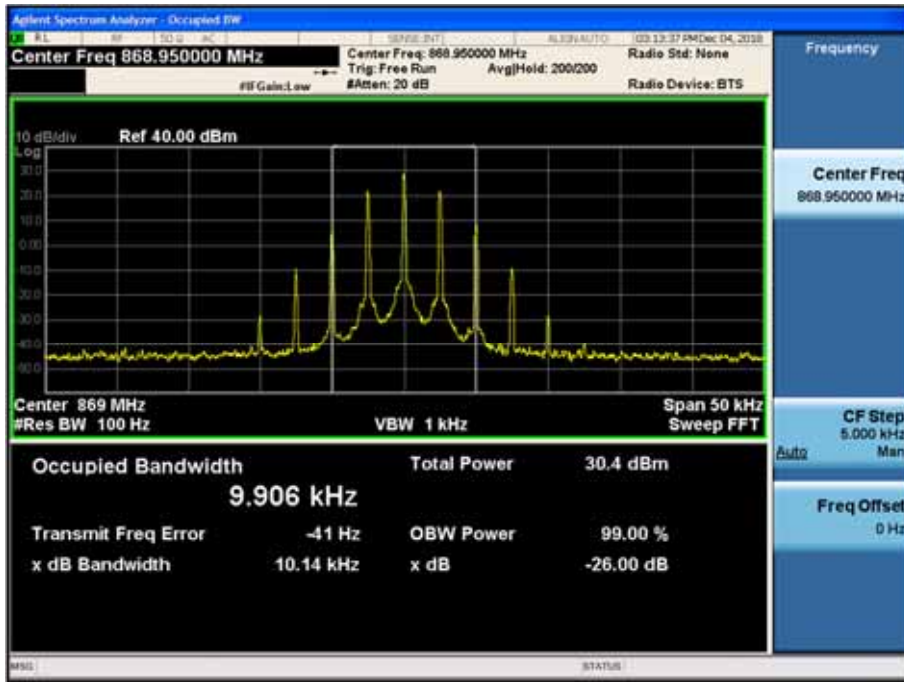

(11K0F3E _ 896.05 MHz)_ Low

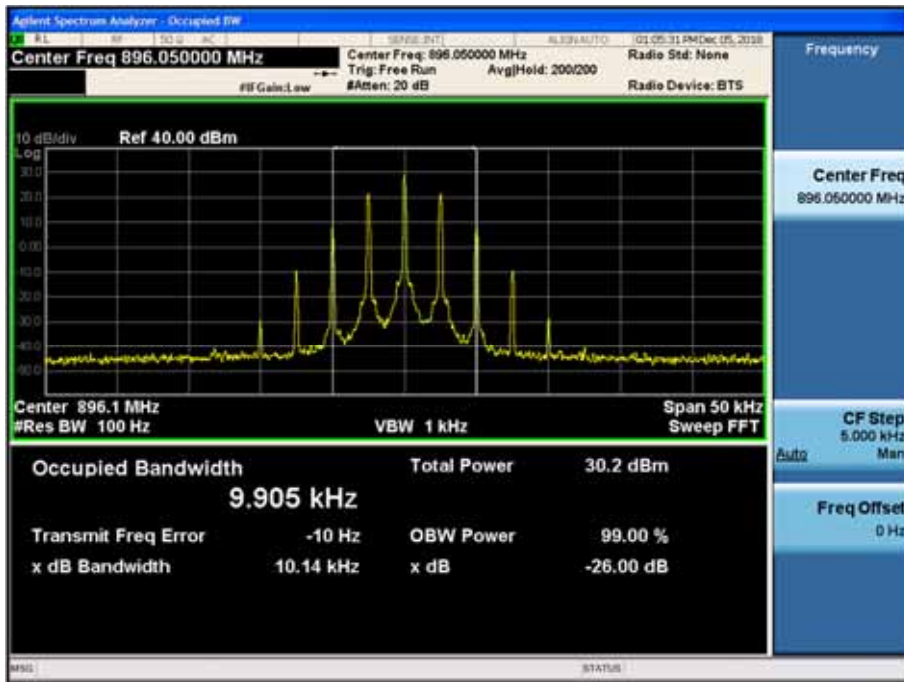

(11K0F3E _ 900.95 MHz)_Low

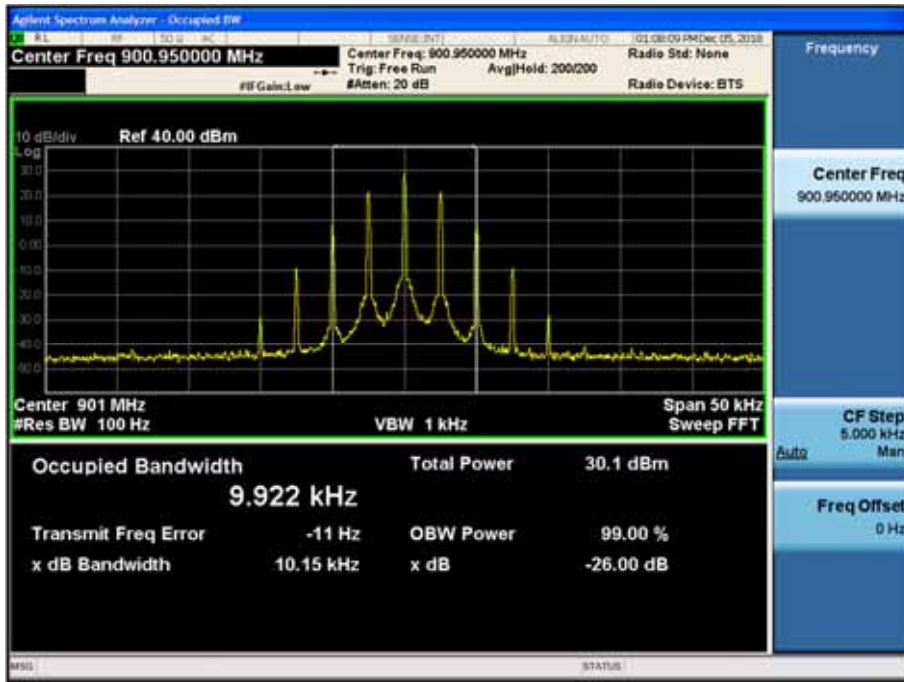

(11K0F3E _ 939.95 MHz)_Low

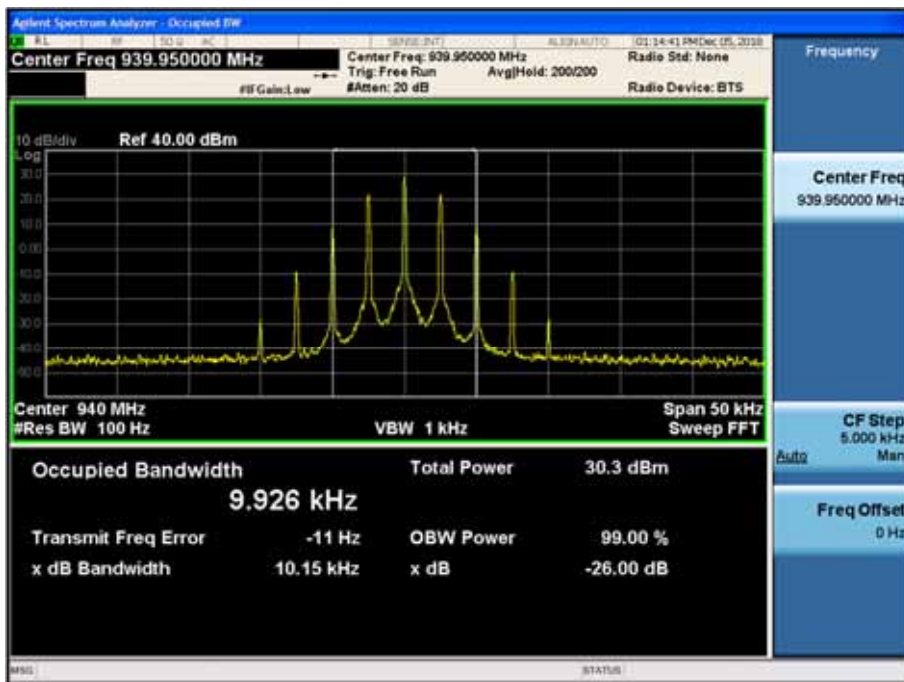

(11K0F3E _ 901.55 MHz)_ Low

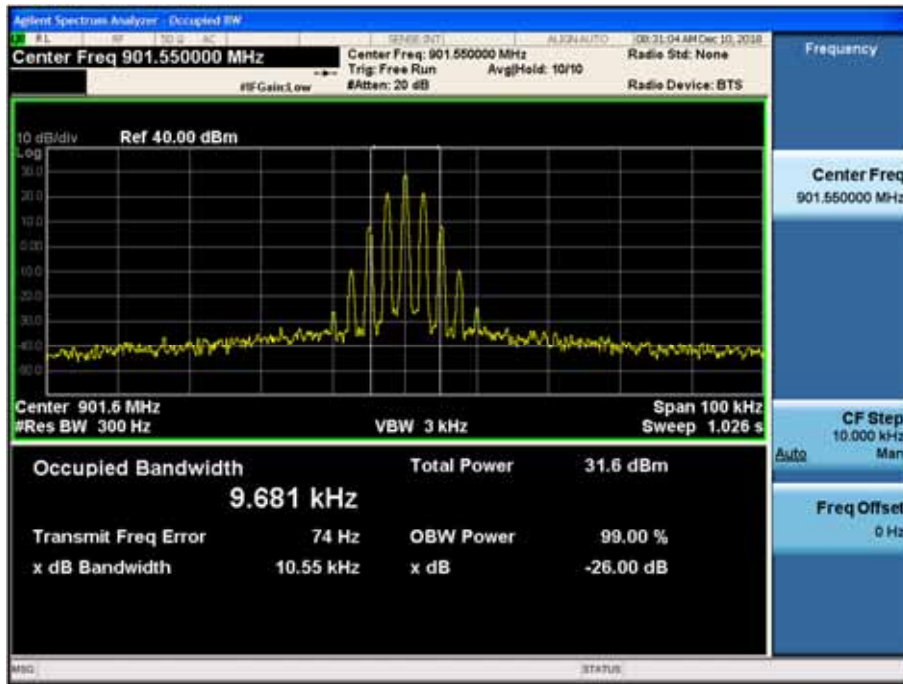

(11K0F3E _ 940.55 MHz)_ Low

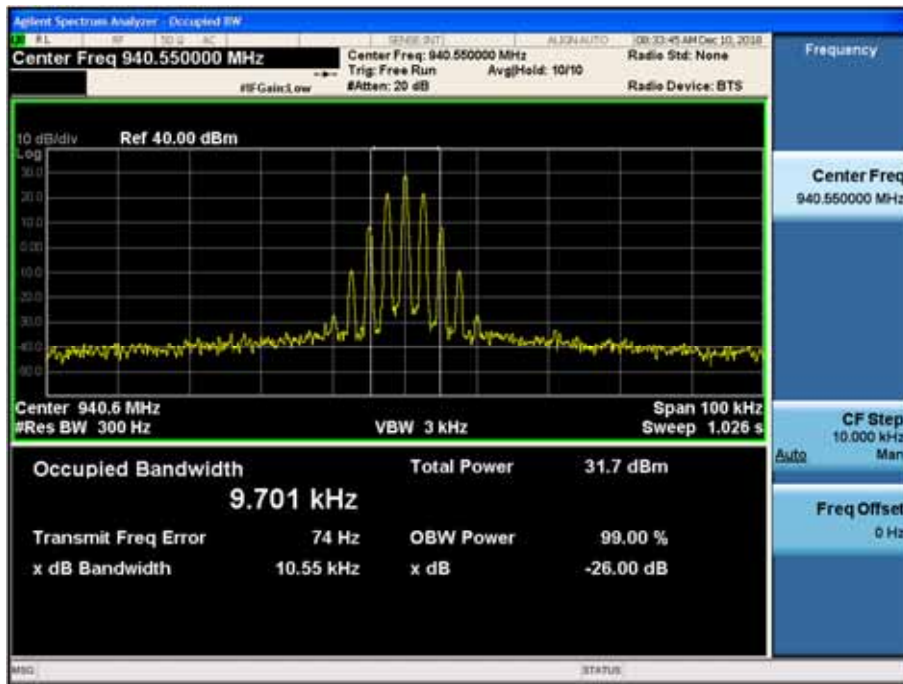

(14K0F3E _ 806.05 MHz)_High

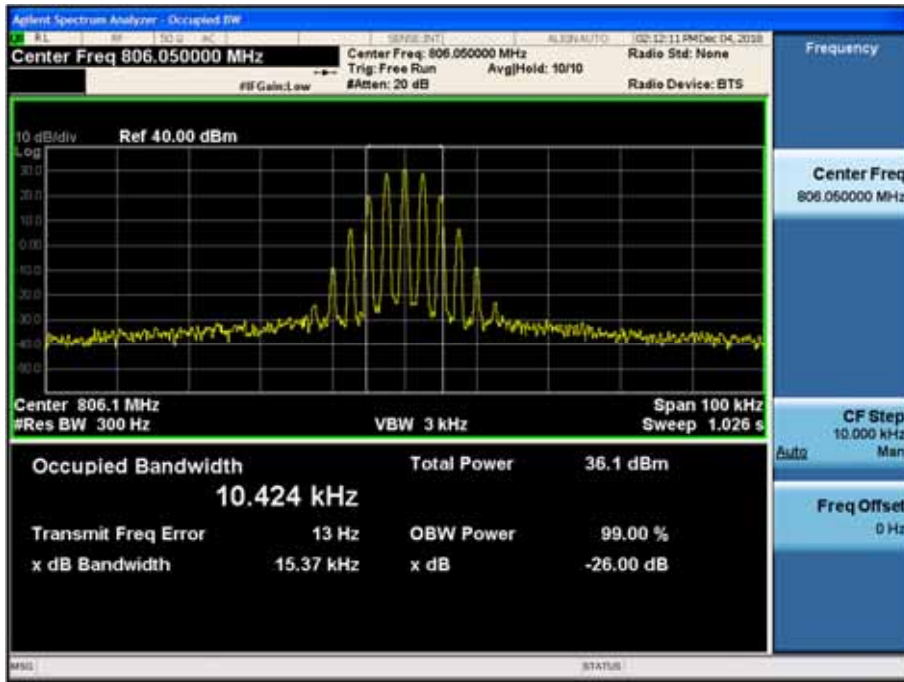

(14K0F3E _ 851.05 MHz)_High

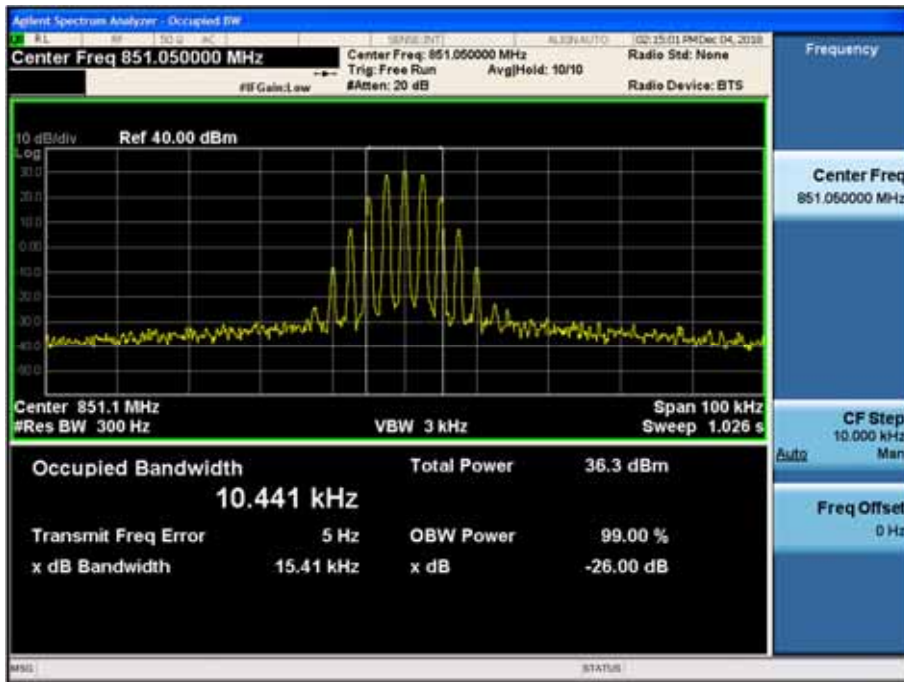

(14K0F3E _ 868.95 MHz)_High

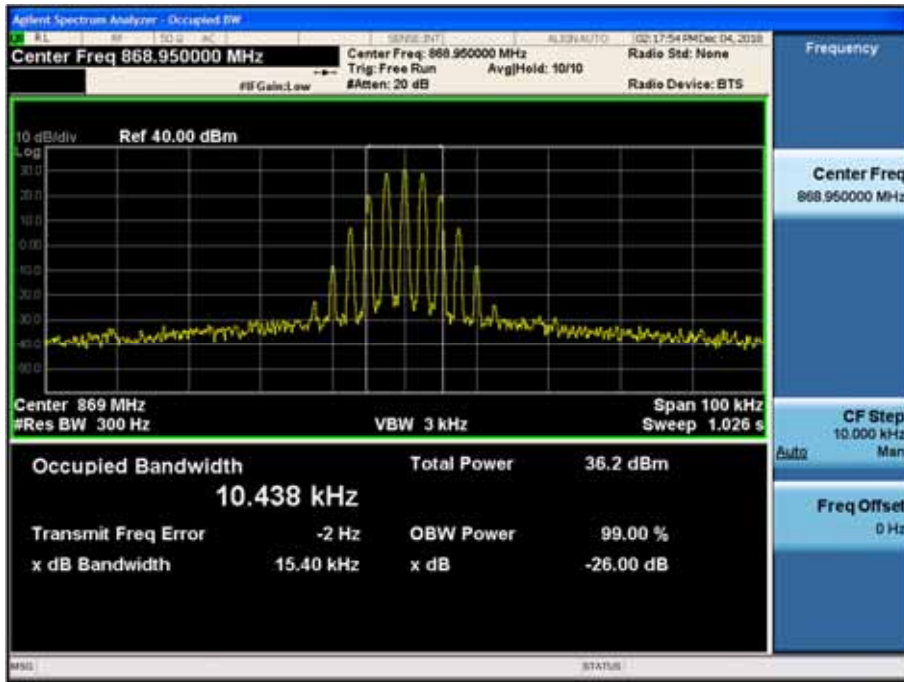

(14K0F3E _ 806.05 MHz)_Low

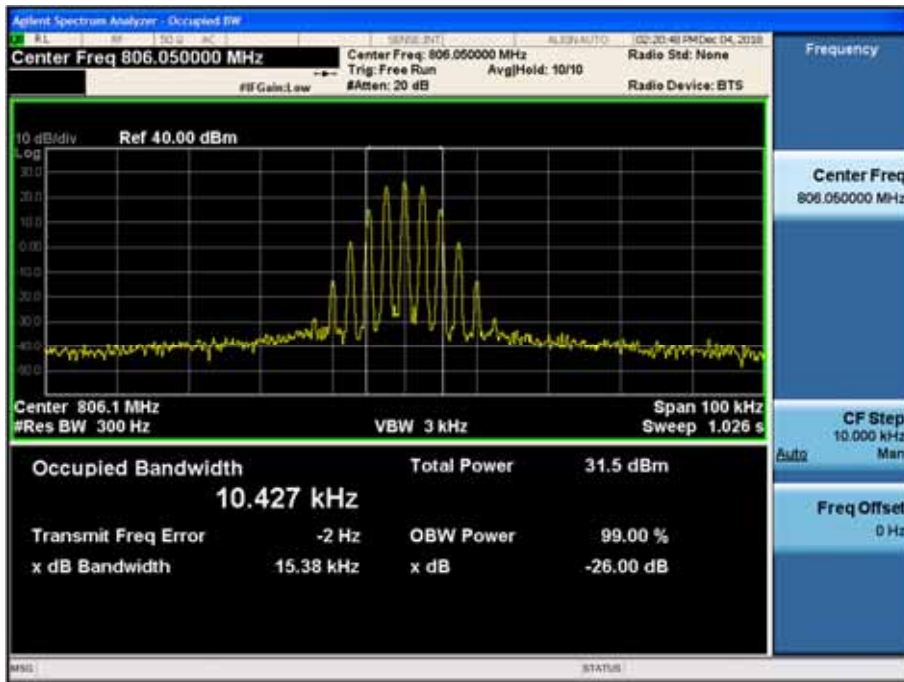

(14K0F3E _ 851.05 MHz)_Low

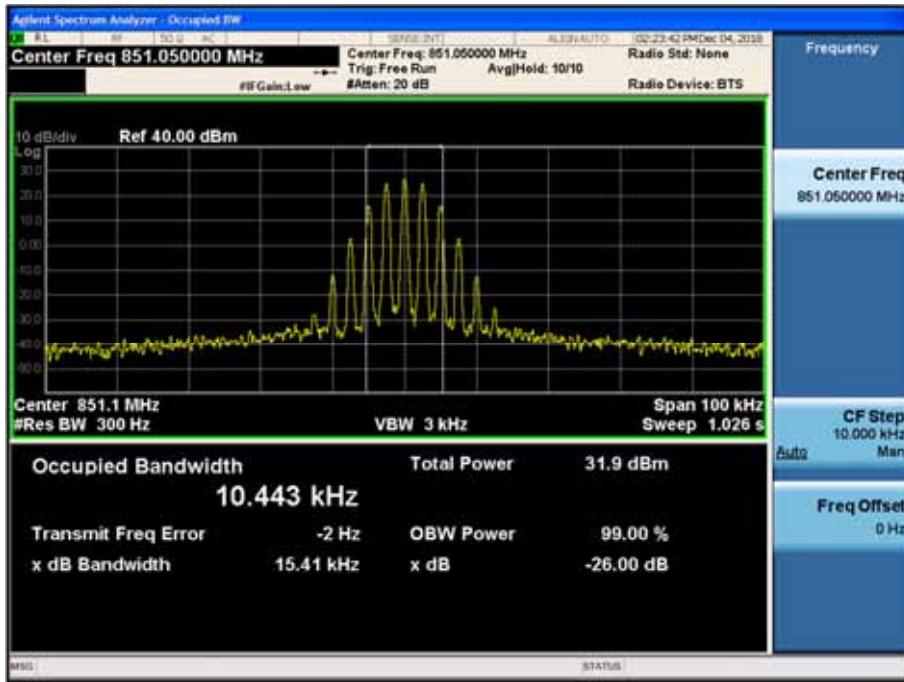

(14K0F3E _ 868.95 MHz)_Low

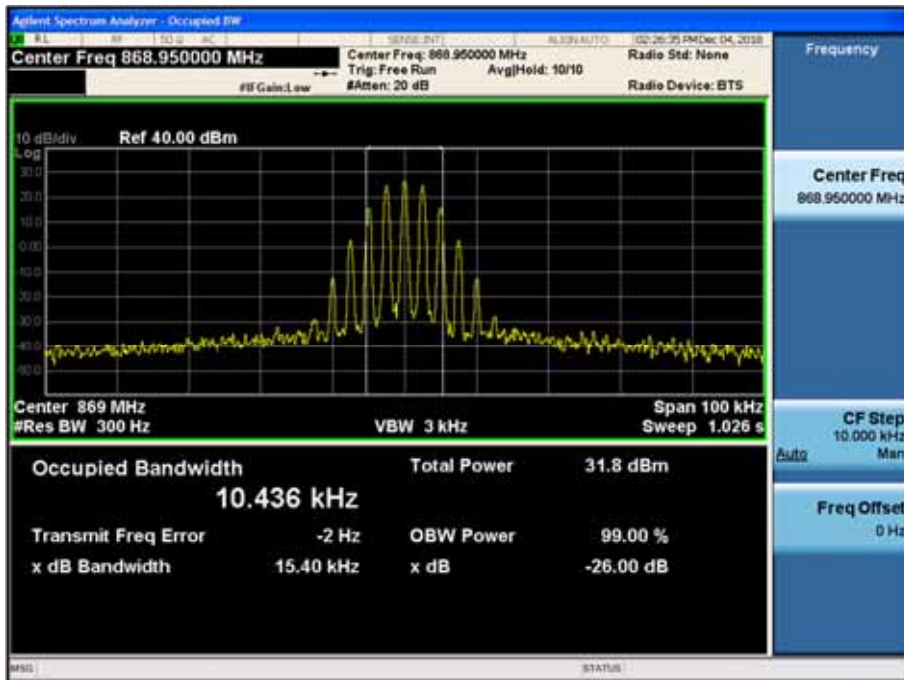

(16K0F3E _ 806.05 MHz)_High

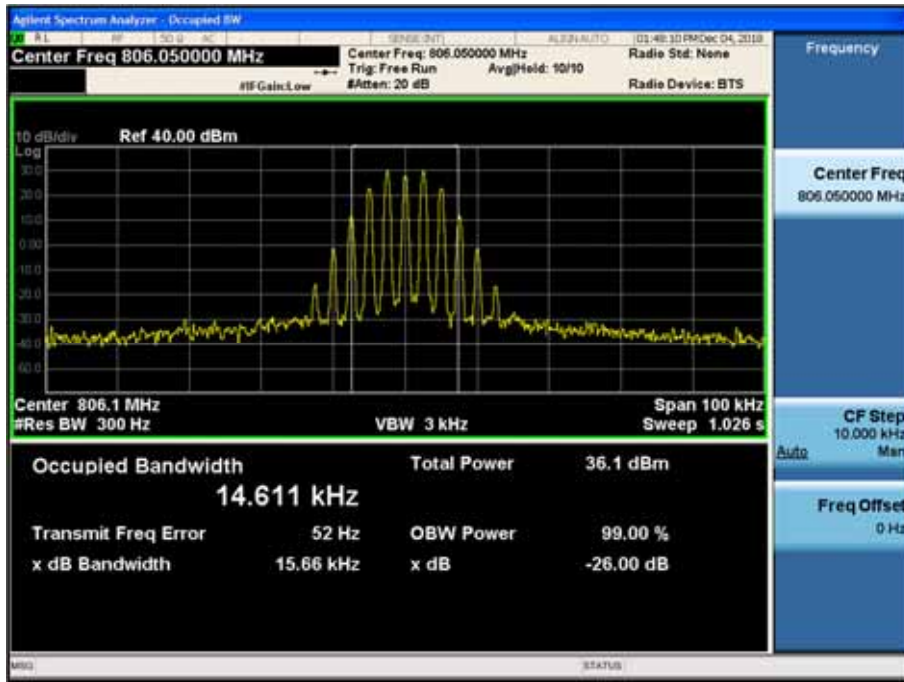

(16K0F3E _ 851.05 MHz)_High

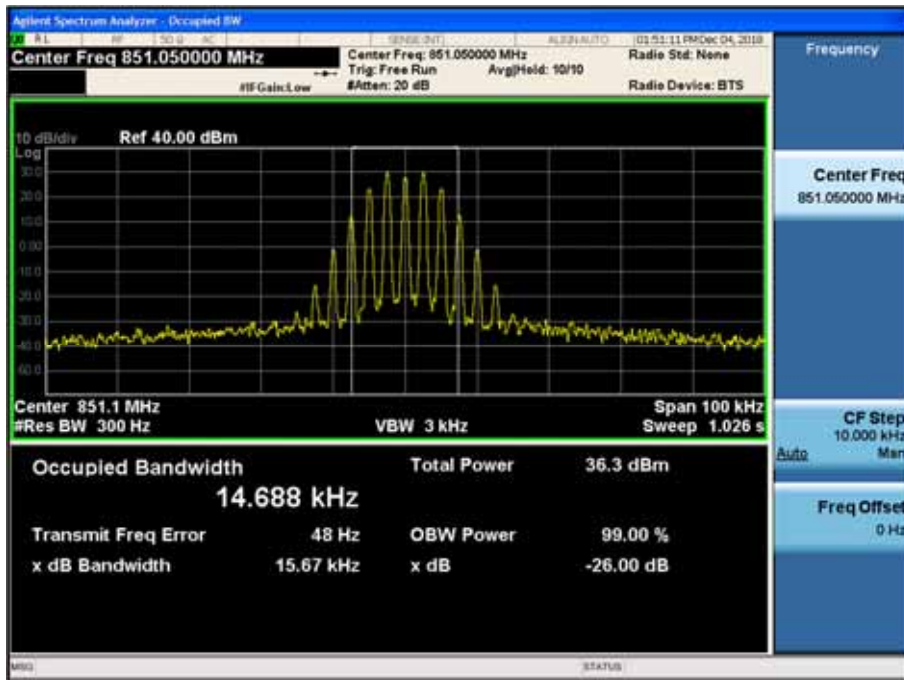

(16K0F3E _ 868.95 MHz)_High



(16K0F3E _ 806.05 MHz)_Low

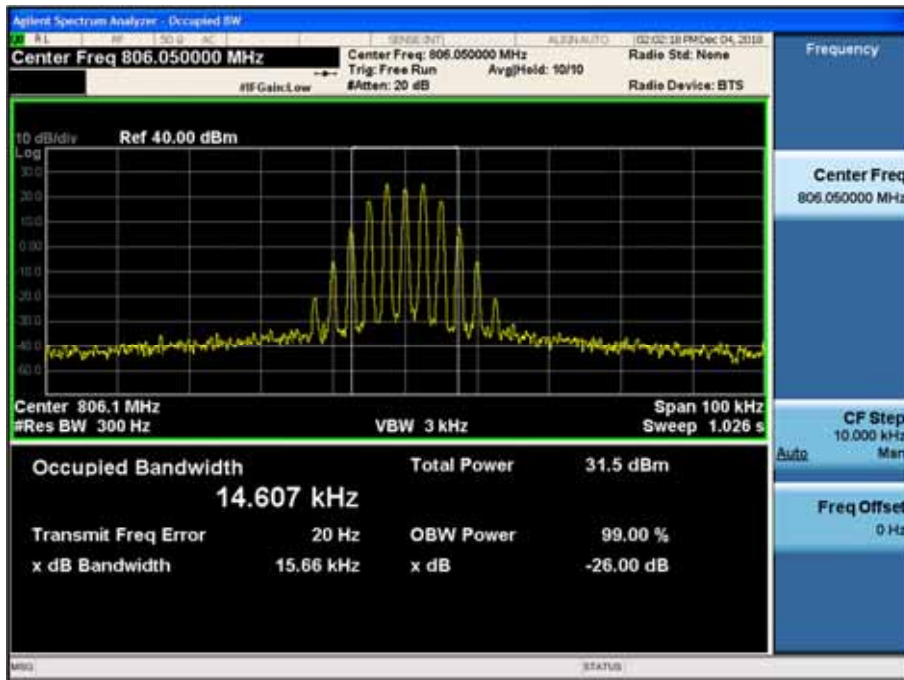

(16K0F3E _ 851.05 MHz)_Low

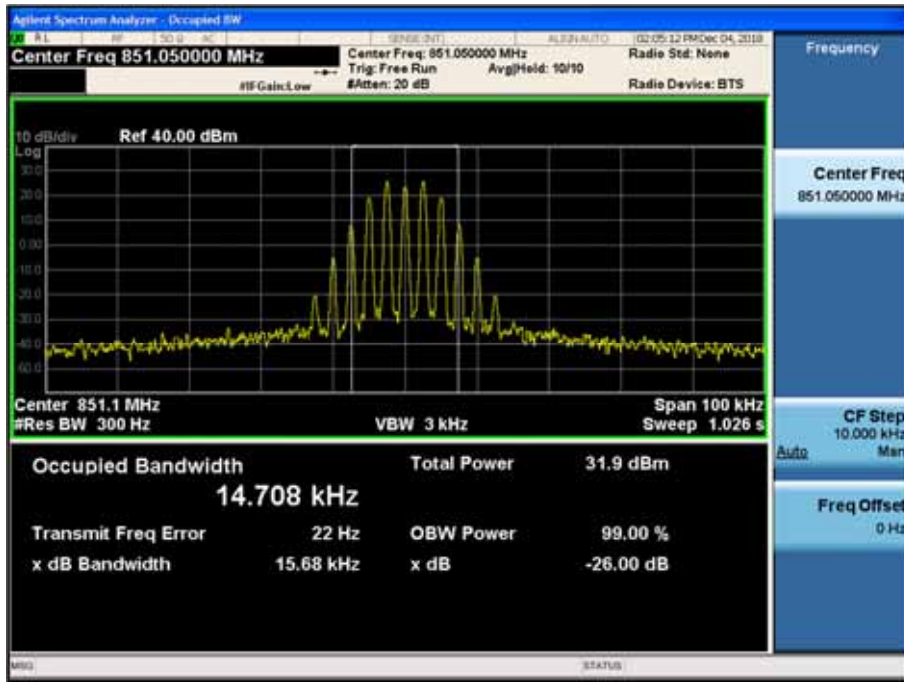

(16K0F3E _ 868.95 MHz)_Low

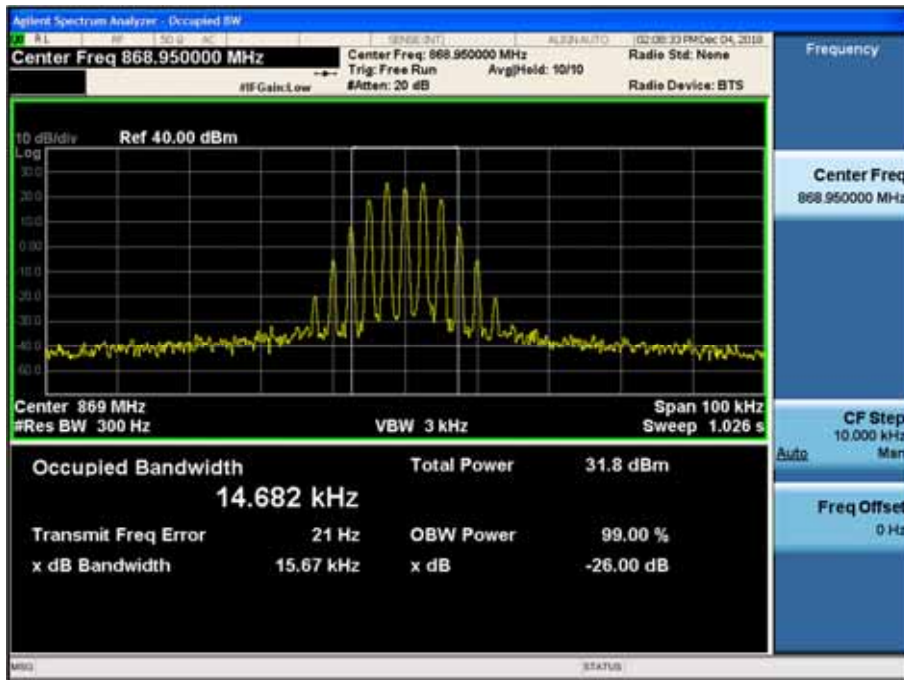

(8K30F1E, 8K30F1D, 8K30F7W _ 806.05 MHz)_High

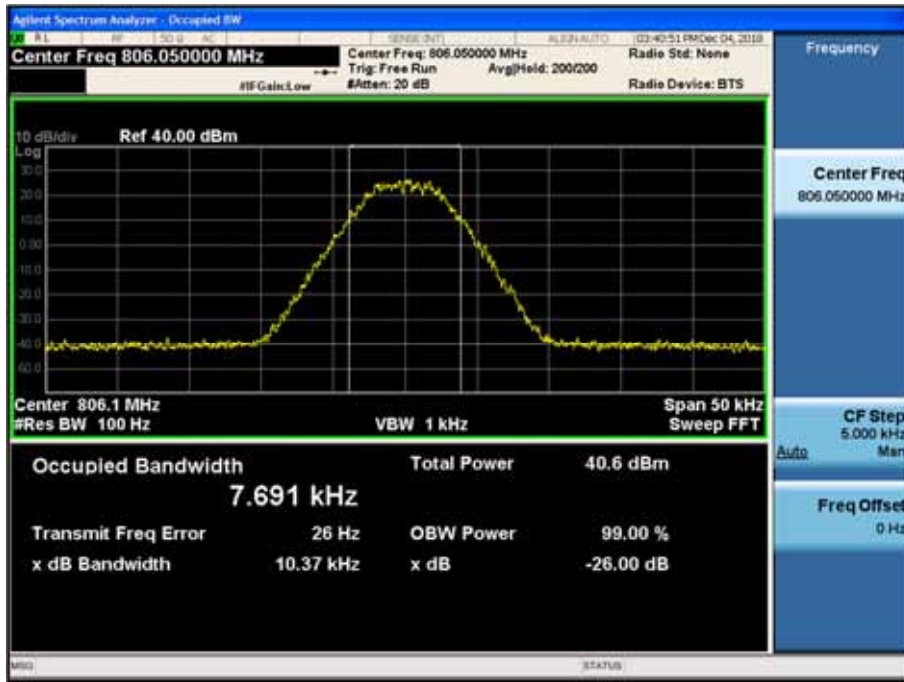

(8K30F1E, 8K30F1D, 8K30F7W _ 851.05 MHz)_High

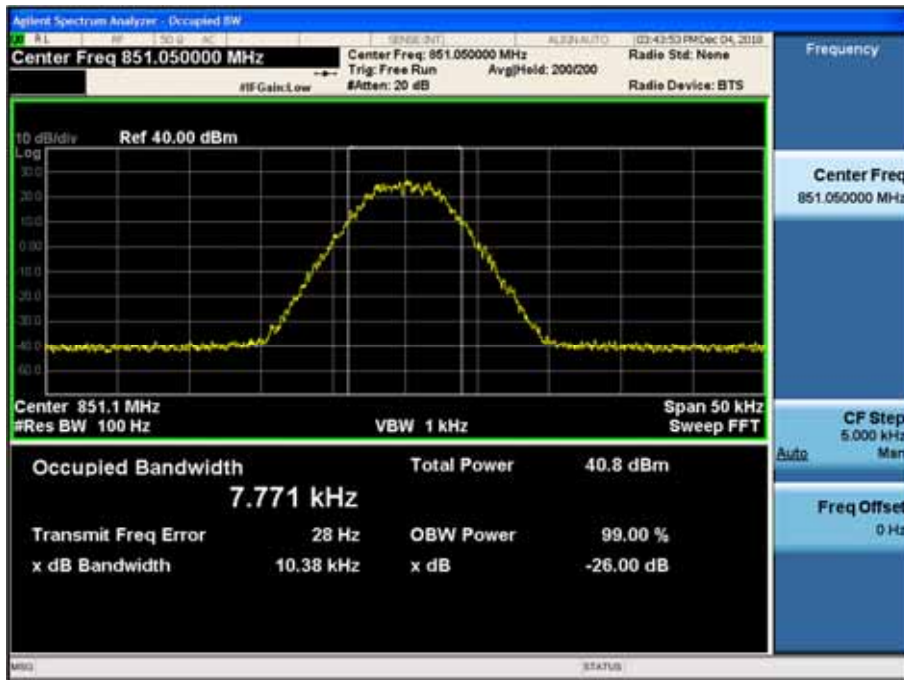

(8K30F1E, 8K30F1D, 8K30F7W _ 868.95 MHz)_High

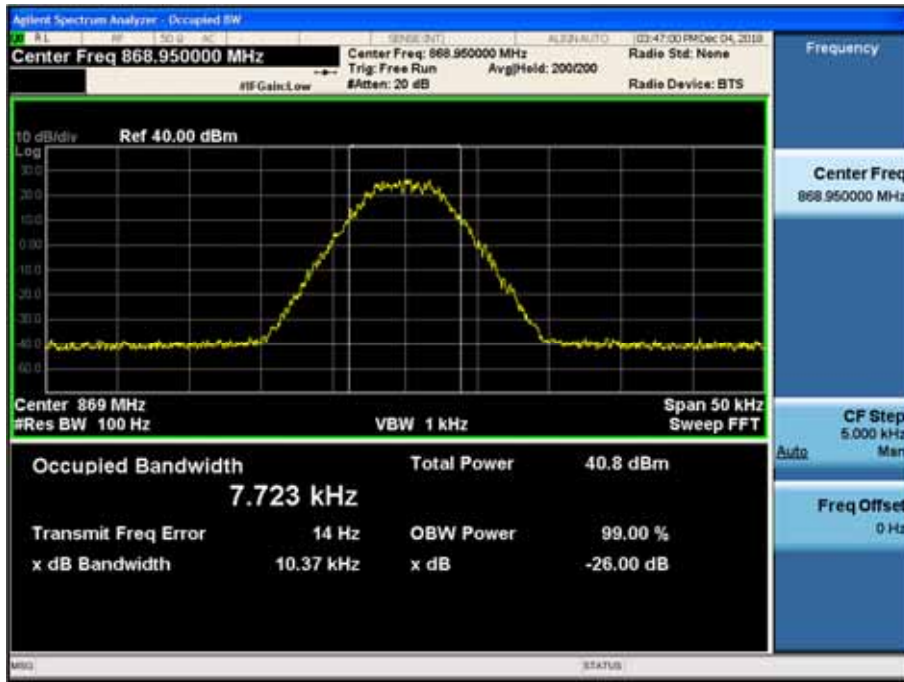

(8K30F1E, 8K30F1D, 8K30F7W _ 896.05 MHz)_High

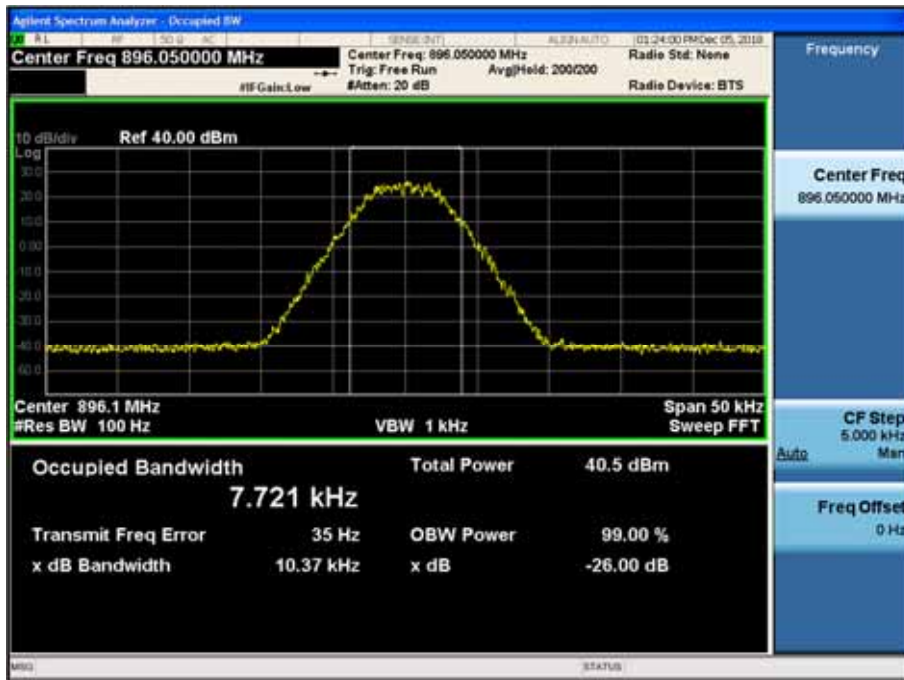

(8K30F1E, 8K30F1D, 8K30F7W _ 900.95 MHz)_ High



(8K30F1E, 8K30F1D, 8K30F7W _ 939.95 MHz)_ High

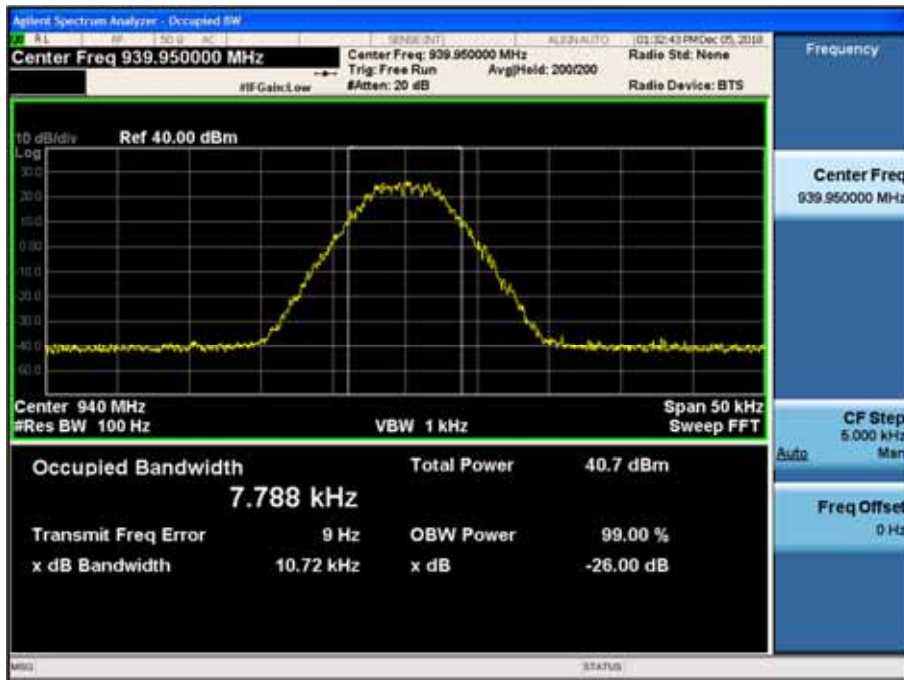

(8K30F1E, 8K30F1D, 8K30F7W _ 901.55 MHz)_ High

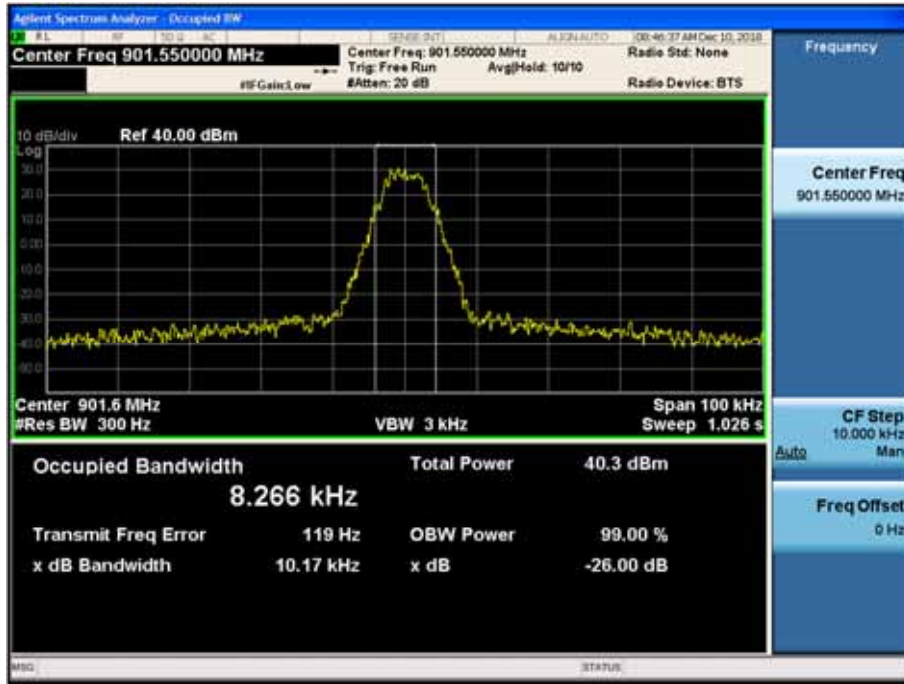

(8K30F1E, 8K30F1D, 8K30F7W _ 940.55 MHz)_ High

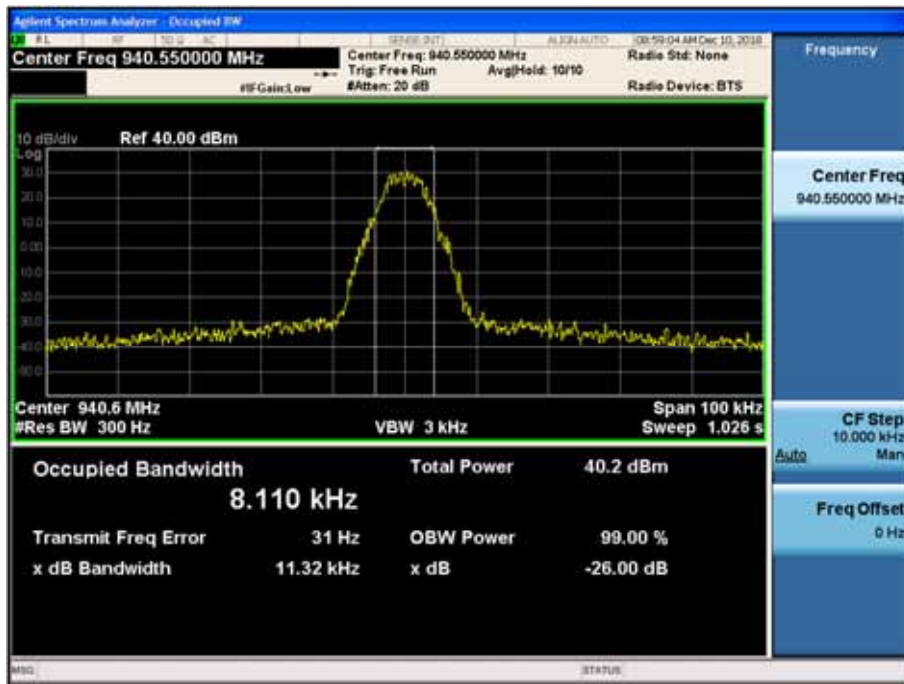

(8K30F1E, 8K30F1D, 8K30F7W _ 806.05 MHz)_ Low

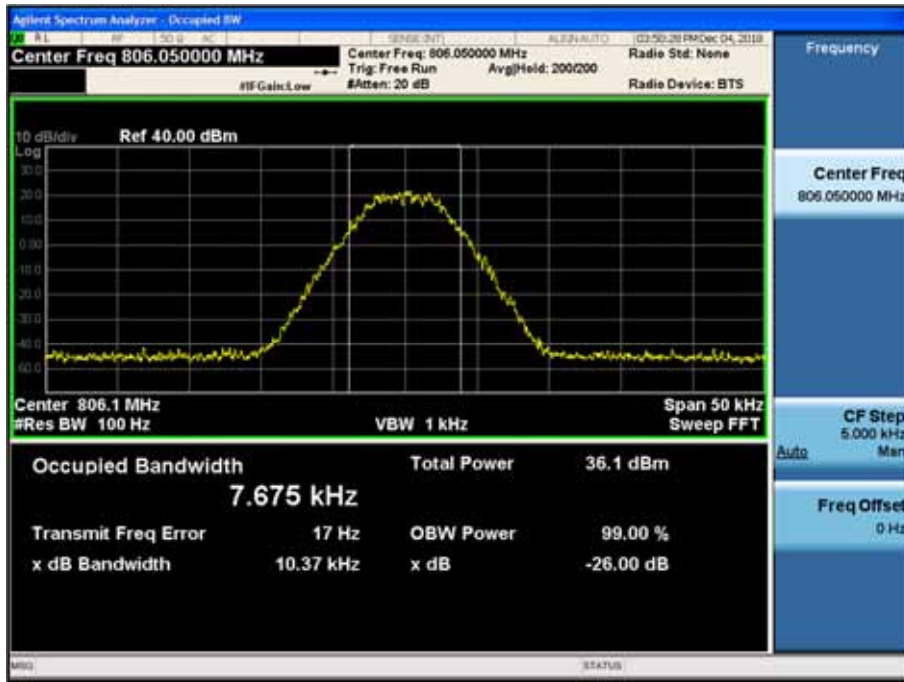

(8K30F1E, 8K30F1D, 8K30F7W _ 851.05 MHz)_ Low

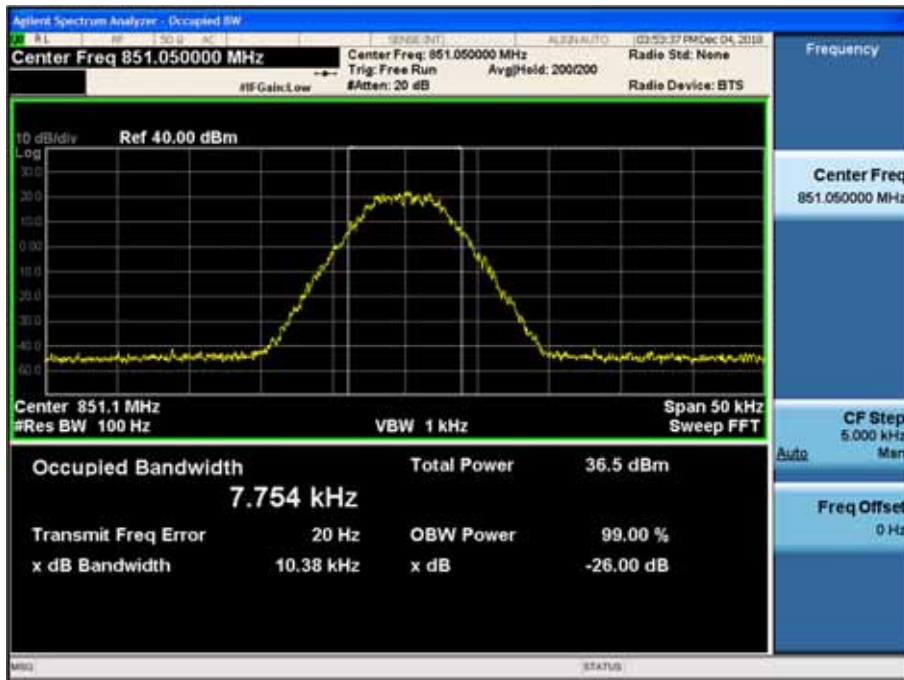

(8K30F1E, 8K30F1D, 8K30F7W _ 868.95 MHz)_ Low

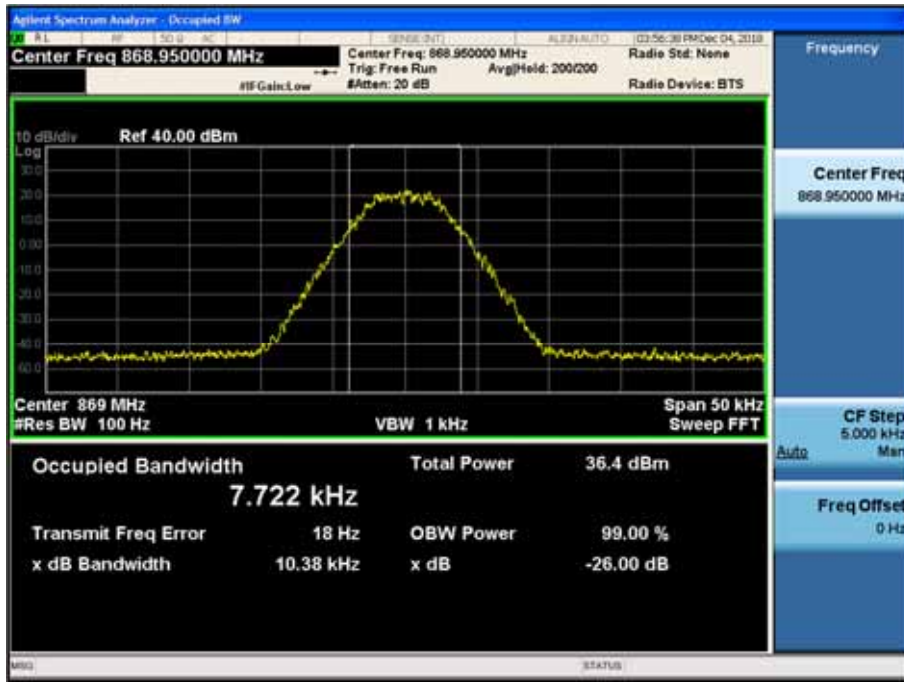

(8K30F1E, 8K30F1D, 8K30F7W _ 896.05 MHz)_ Low

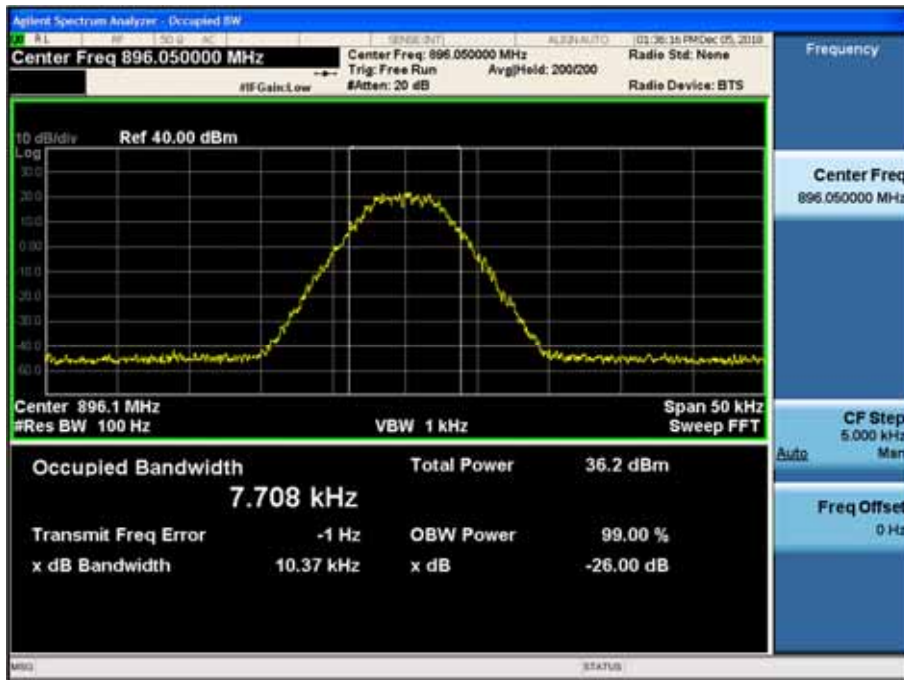

(8K30F1E, 8K30F1D, 8K30F7W _ 900.95 MHz)_Low

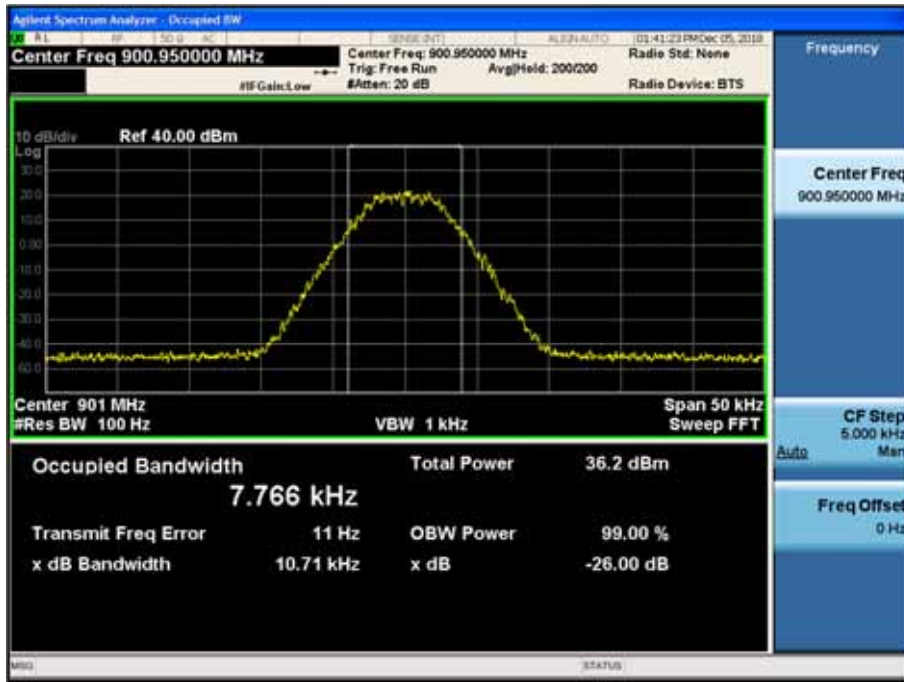

(8K30F1E, 8K30F1D, 8K30F7W _ 939.95 MHz)_Low

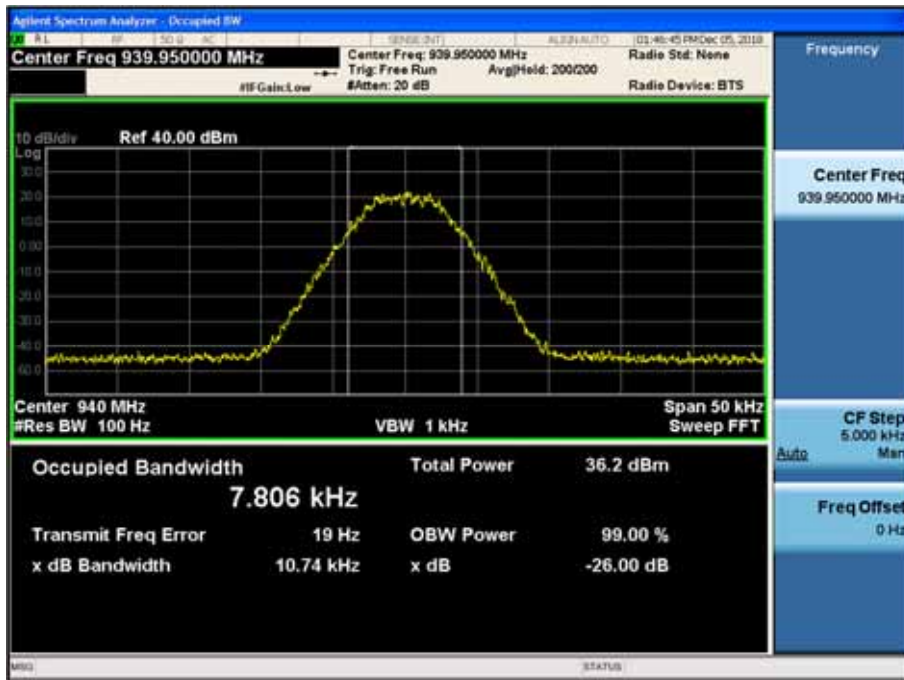

(8K30F1E, 8K30F1D, 8K30F7W _ 901.55 MHz)_ Low

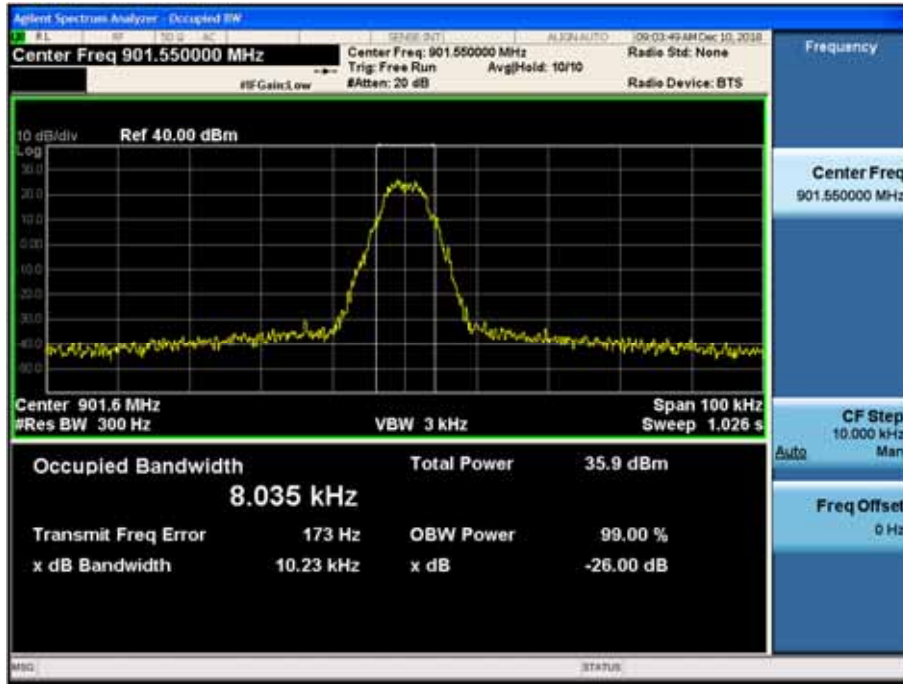

(8K30F1E, 8K30F1D, 8K30F7W _ 940.55 MHz)_ Low

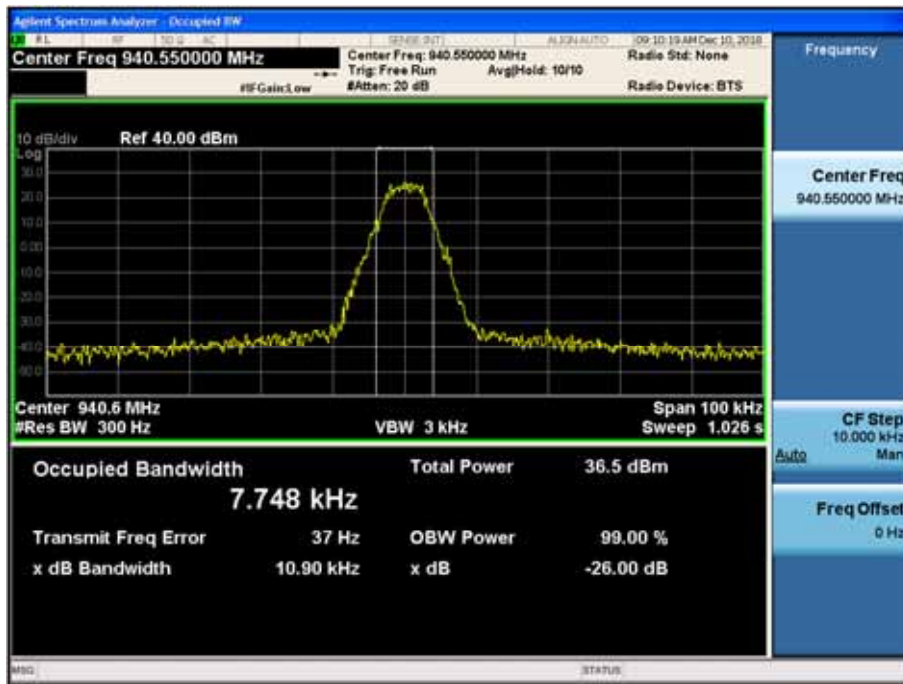

(7K60FXE, 7K60FXD _ 806.05 MHz)_High



(7K60FXE, 7K60FXD _ 851.05 MHz)_High

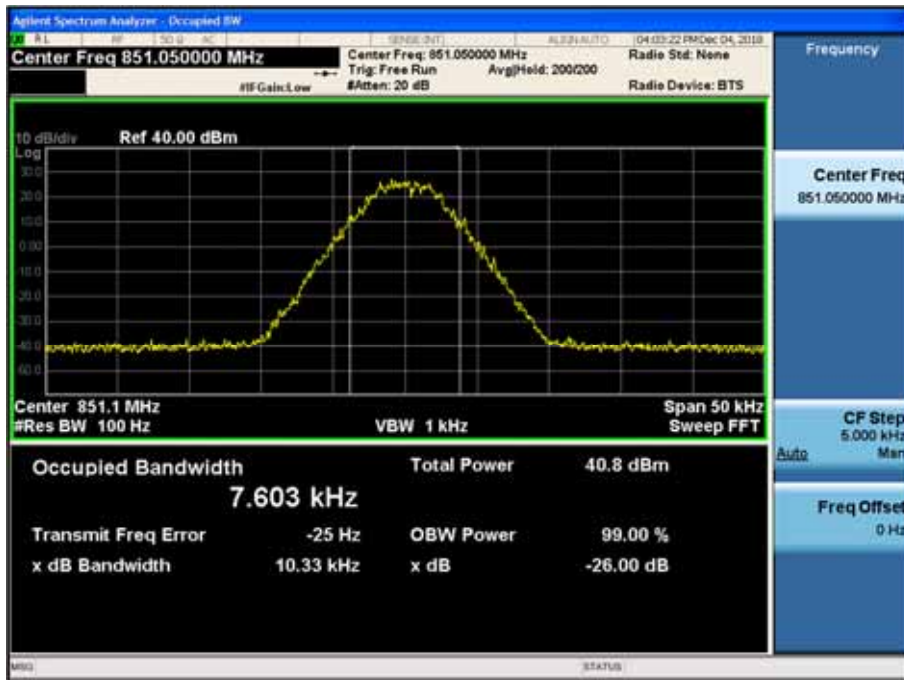

(7K60FXE, 7K60FXD _ 868.95 MHz)_High

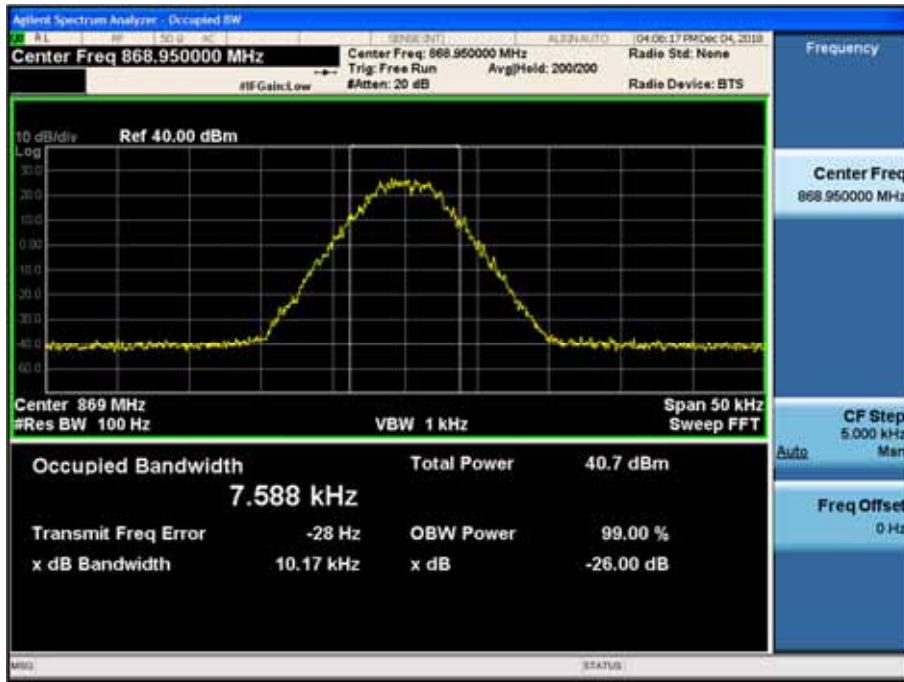

(7K60FXE, 7K60FXD _ 896.05 MHz)_ High

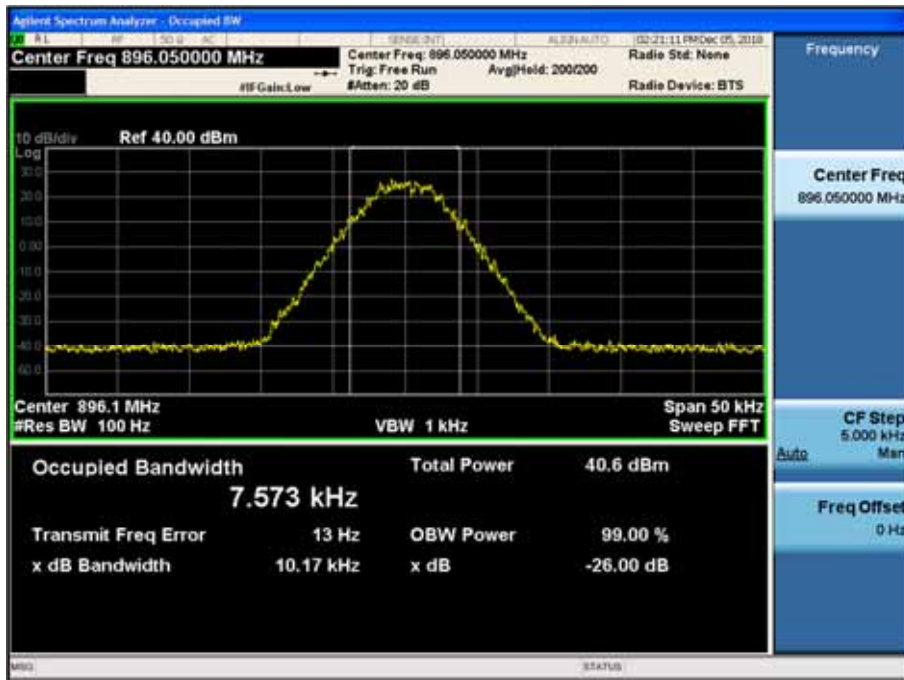

(7K60FXE, 7K60FXD _ 900.95 MHz)_ High

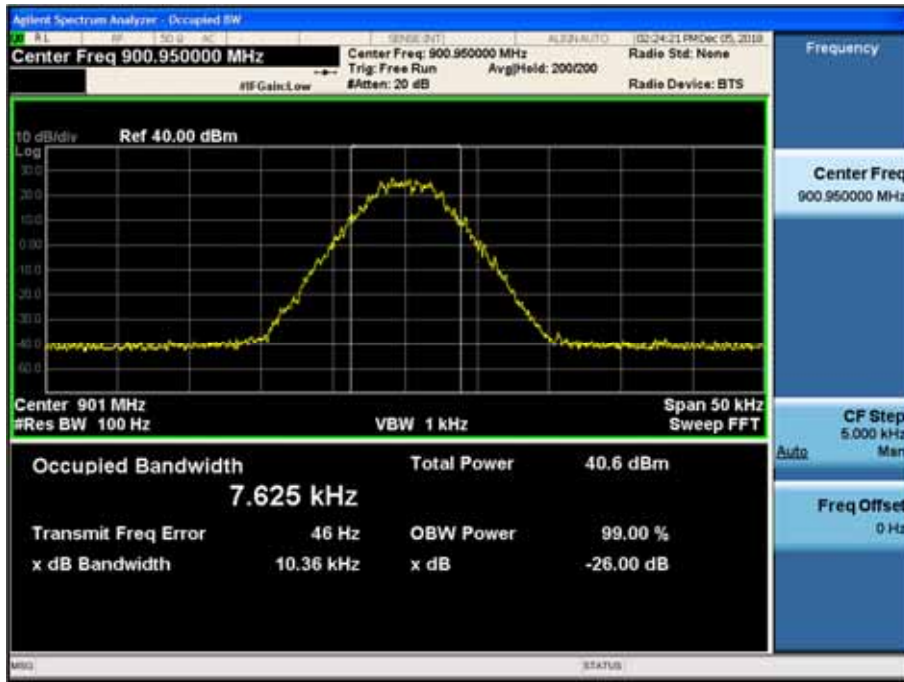

(7K60FXE, 7K60FXD _ 939.95 MHz)_ High



(7K60FXE, 7K60FXD _ 901.55 MHz)_High

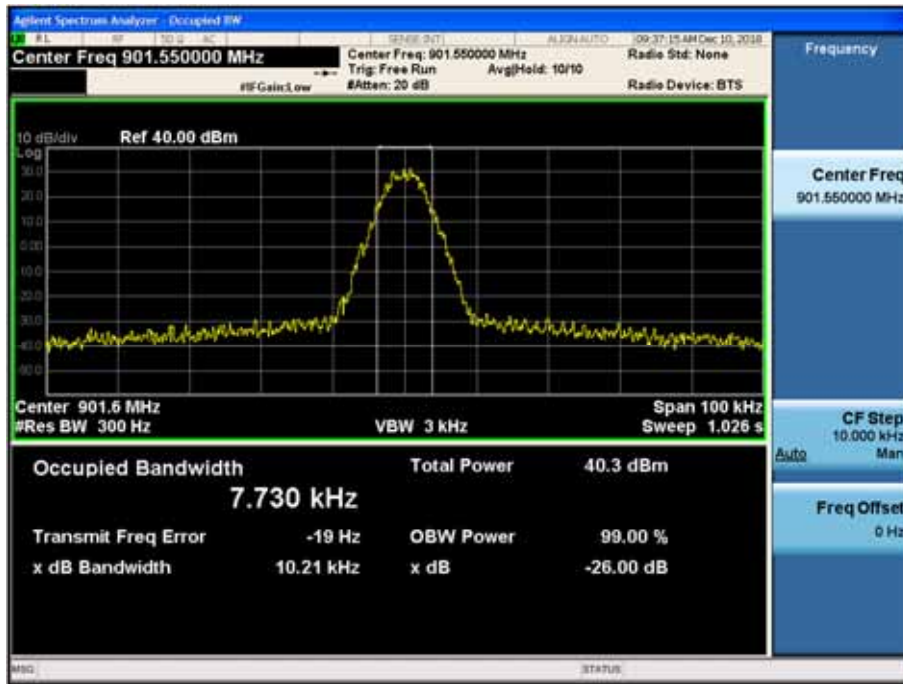

(7K60FXE, 7K60FXD _ 940.55 MHz)_High

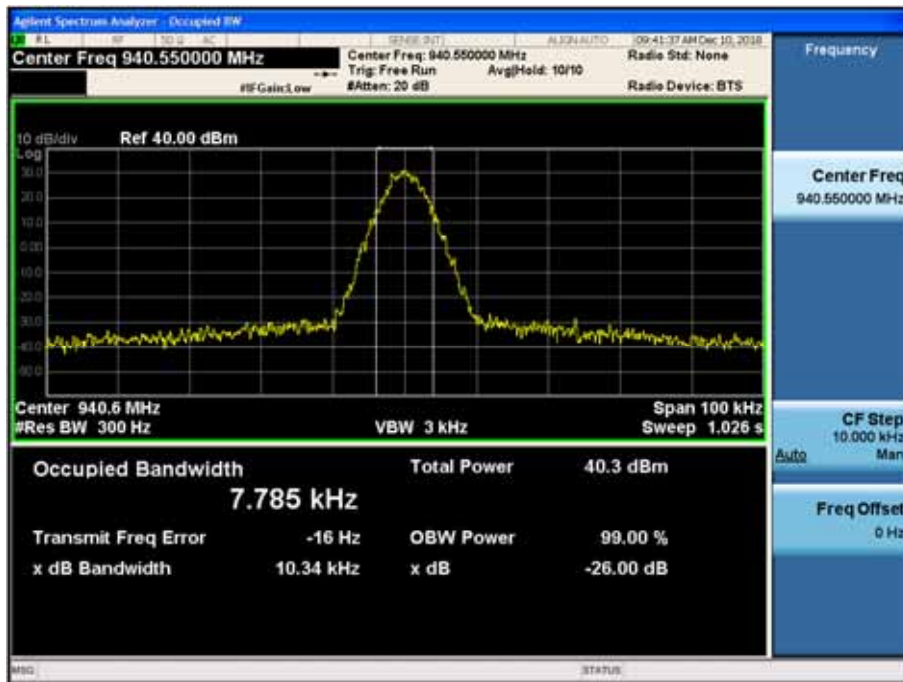

(7K60FXE, 7K60FXD _ 806.05 MHz)_ Low

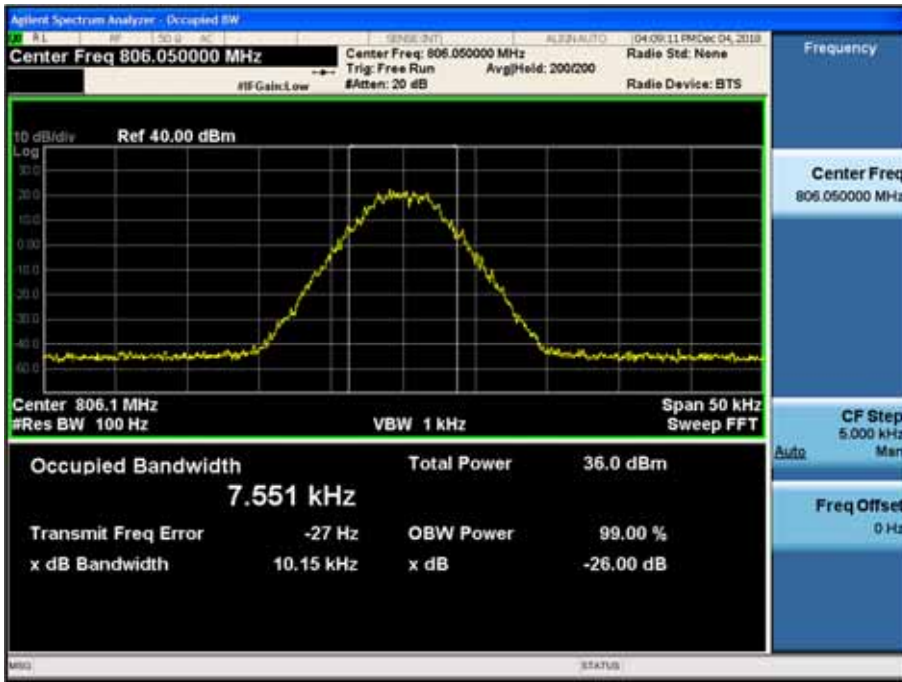

(7K60FXE, 7K60FXD _ 851.05 MHz)_ Low

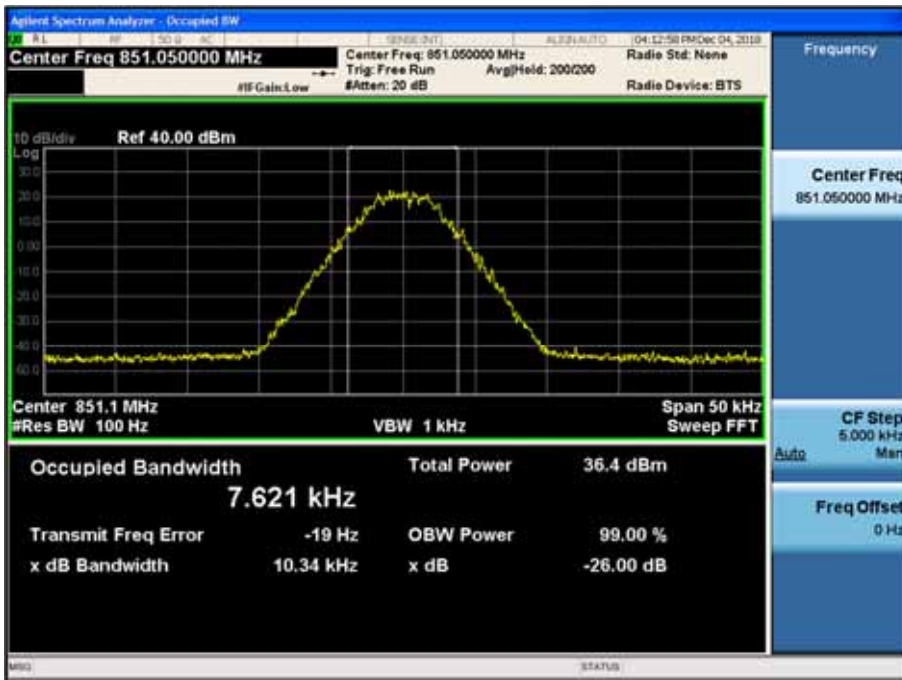

(7K60FXE, 7K60FXD _ 868.95 MHz)_ Low

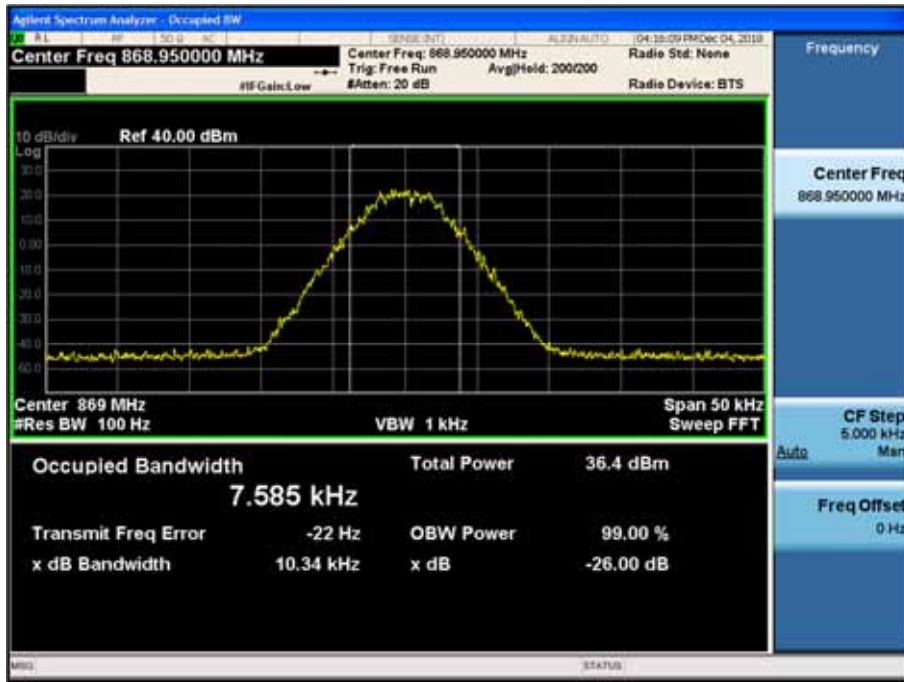

(7K60FXE, 7K60FXD _ 896.05 MHz)_ Low

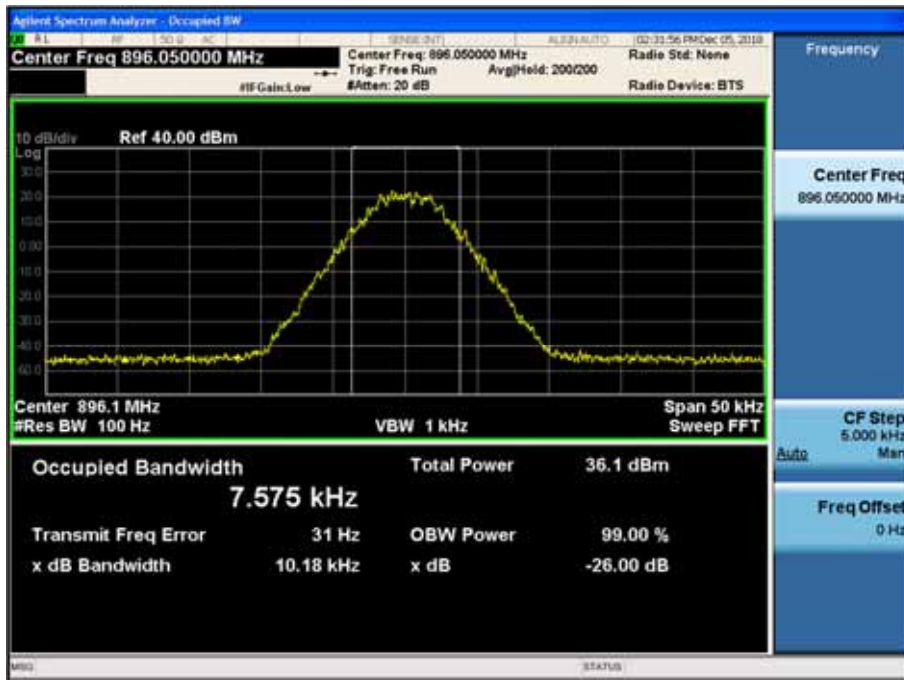

(7K60FXE, 7K60FXD _ 900.95 MHz)_Low

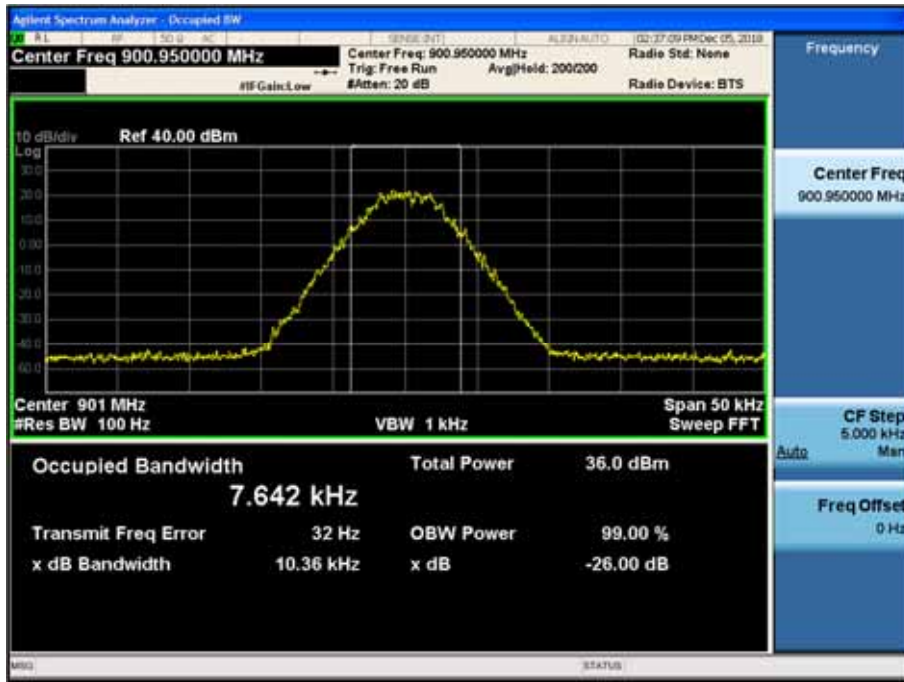

(7K60FXE, 7K60FXD _ 939.95 MHz)_Low

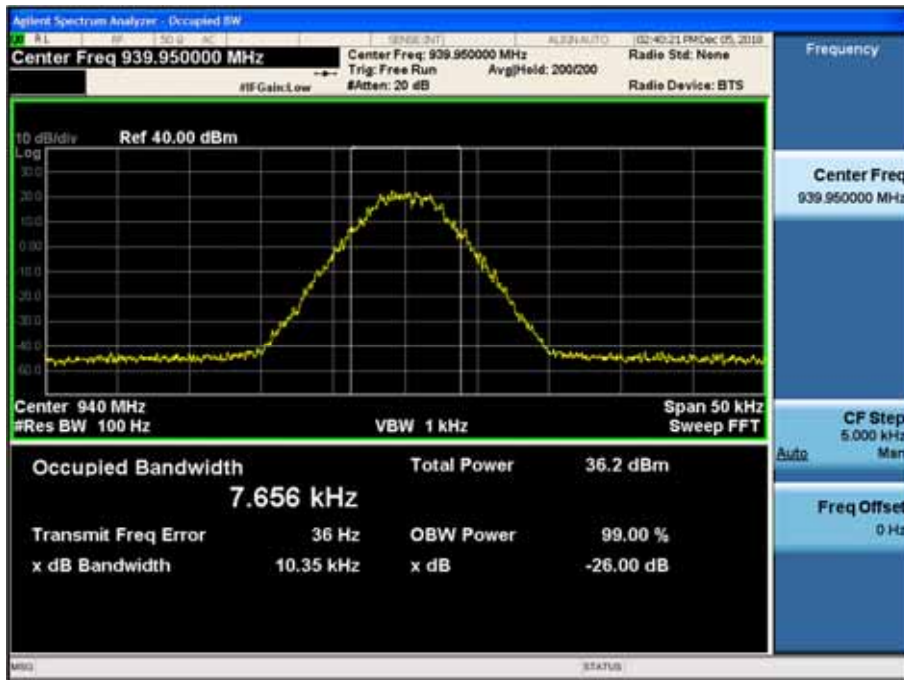

(7K60FXE, 7K60FXD _ 901.55 MHz)_Low

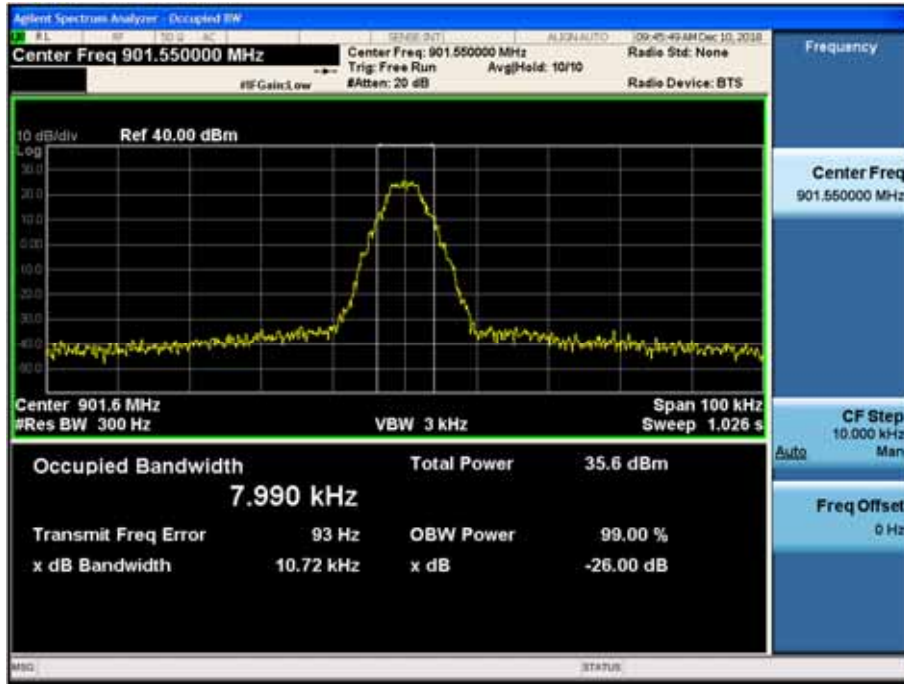

(7K60FXE, 7K60FXD _ 940.55 MHz)_Low

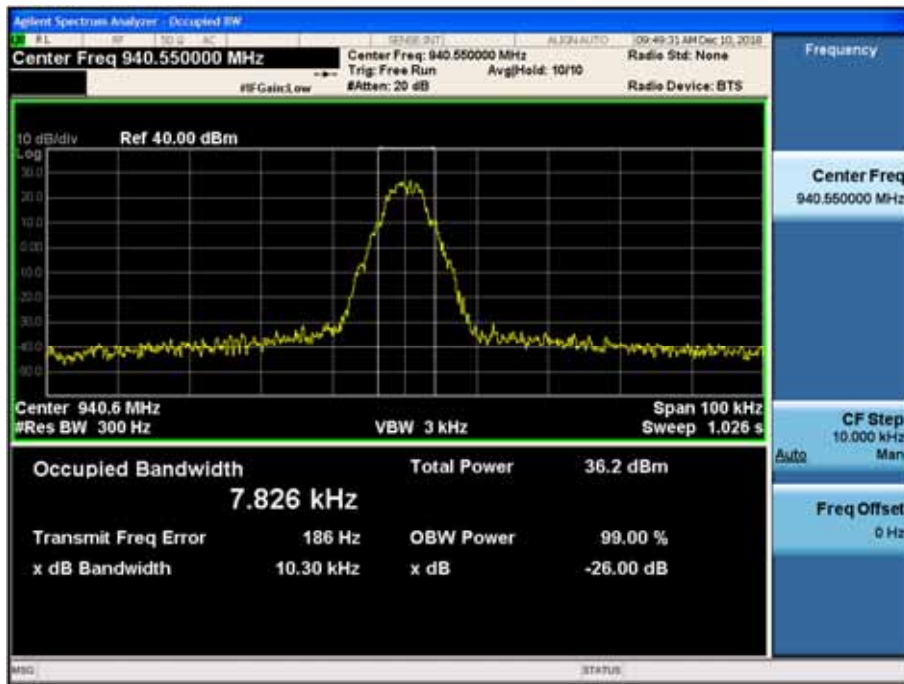

(4K00F1E, 4K00F1D, 4K00F7W _ 806.05 MHz)_High

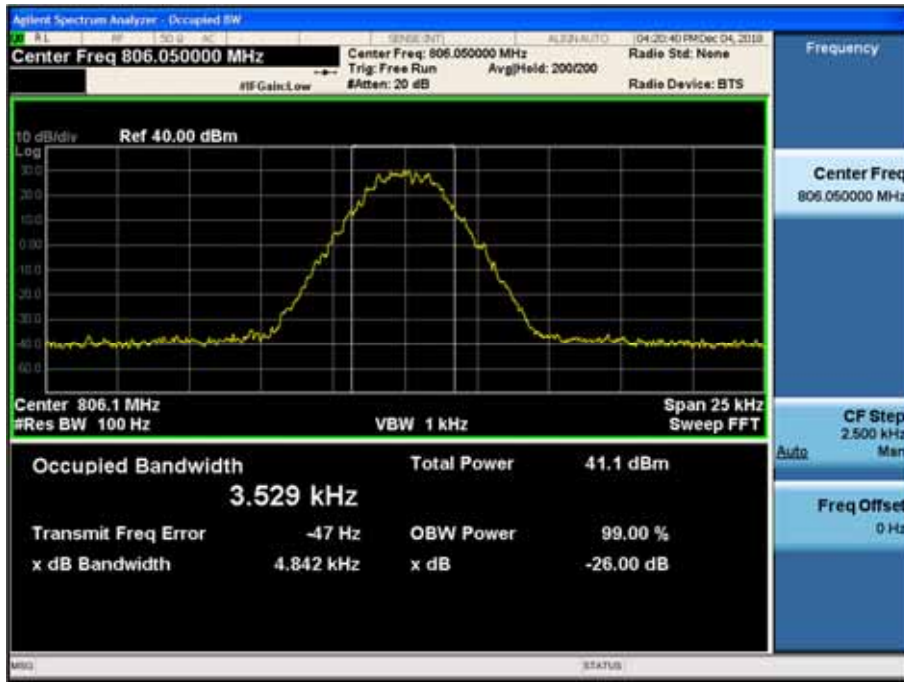

(4K00F1E, 4K00F1D, 4K00F7W _ 851.05 MHz)_High

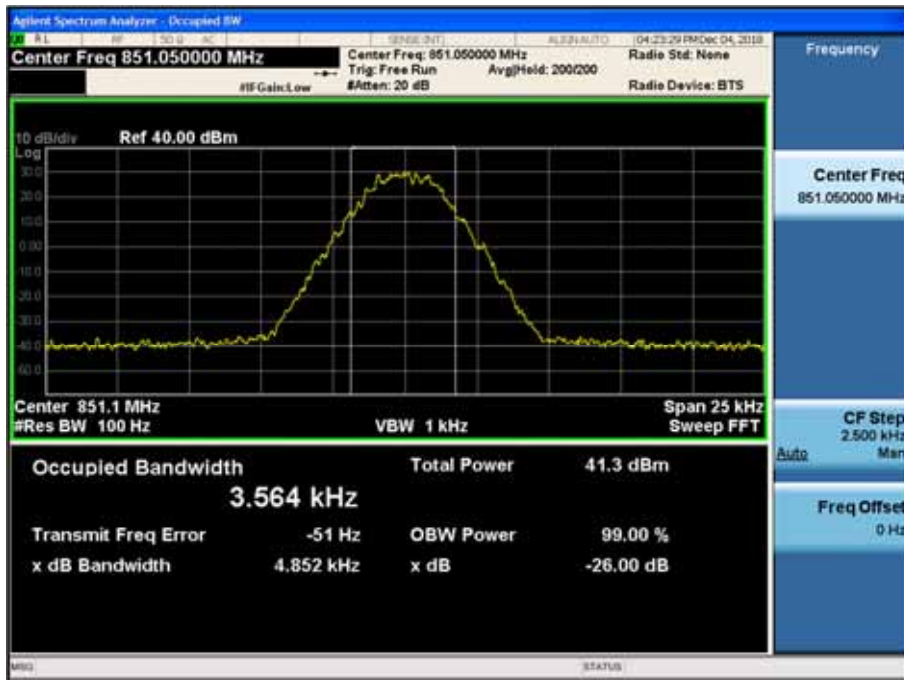

(4K00F1E, 4K00F1D, 4K00F7W _ 868.95 MHz)_High

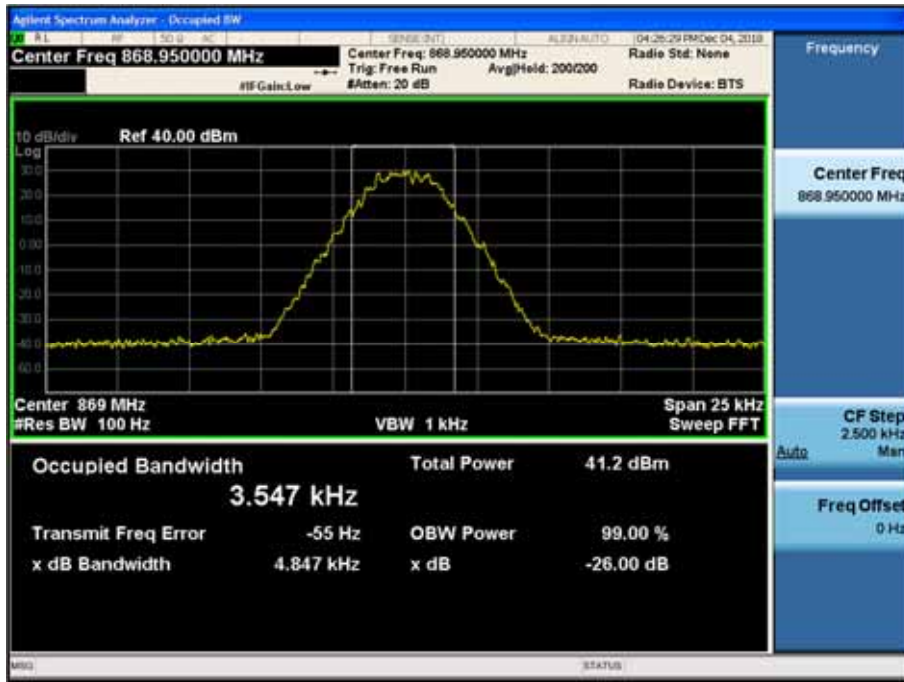

(4K00F1E, 4K00F1D, 4K00F7W _ 896.05 MHz)_ High

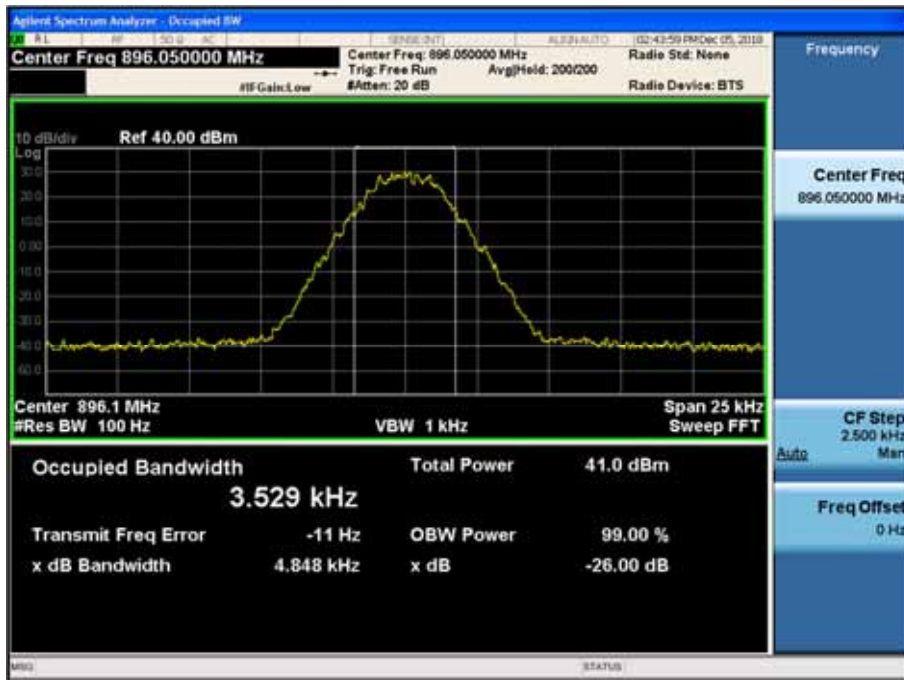

(4K00F1E, 4K00F1D, 4K00F7W _ 900.95 MHz)_ High

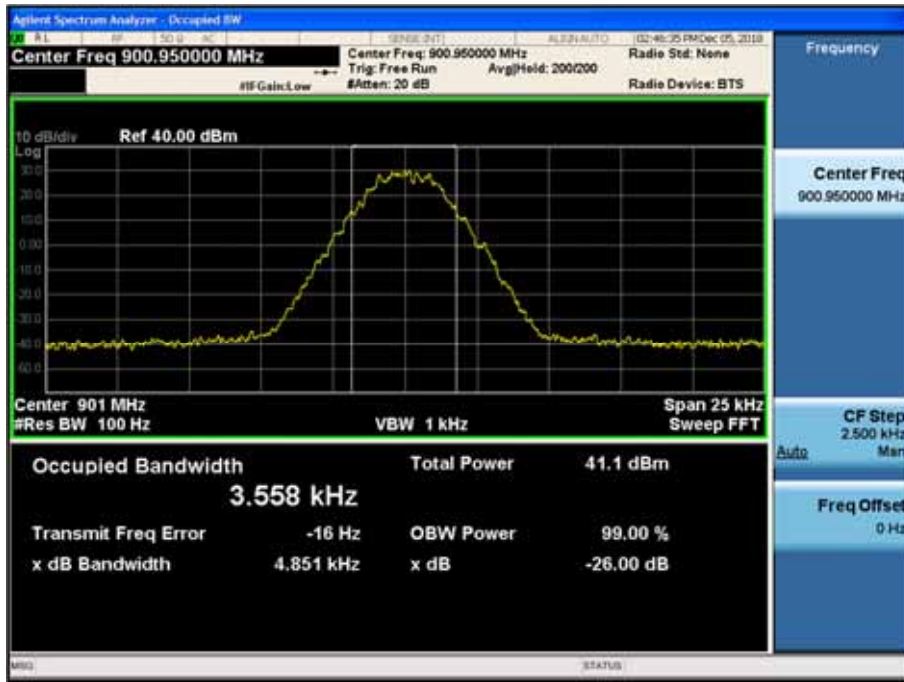

(4K00F1E, 4K00F1D, 4K00F7W _ 939.95 MHz)_ High

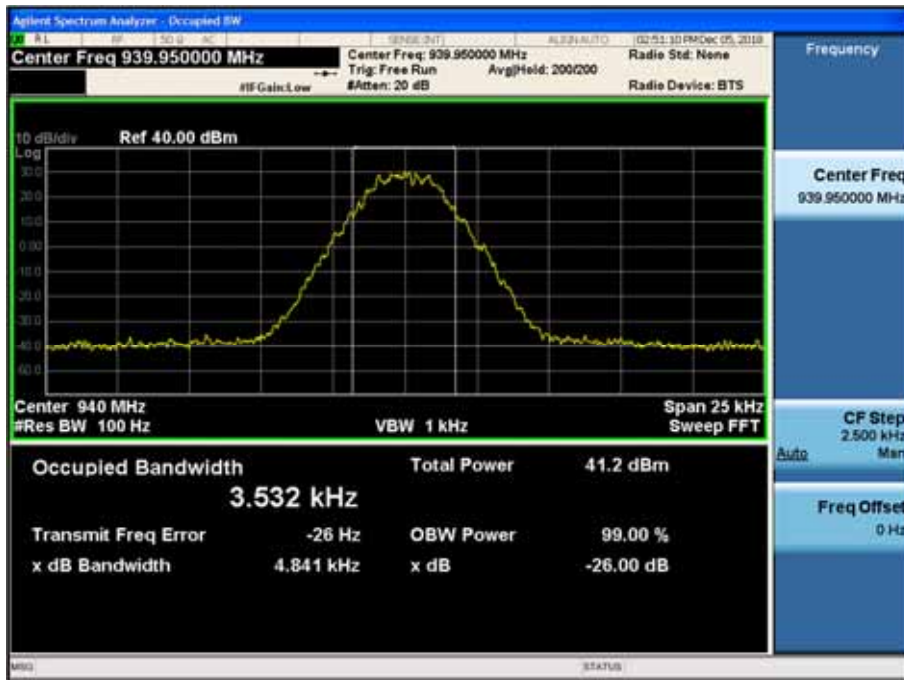

(4K00F1E, 4K00F1D, 4K00F7W _ 901.55 MHz)_High

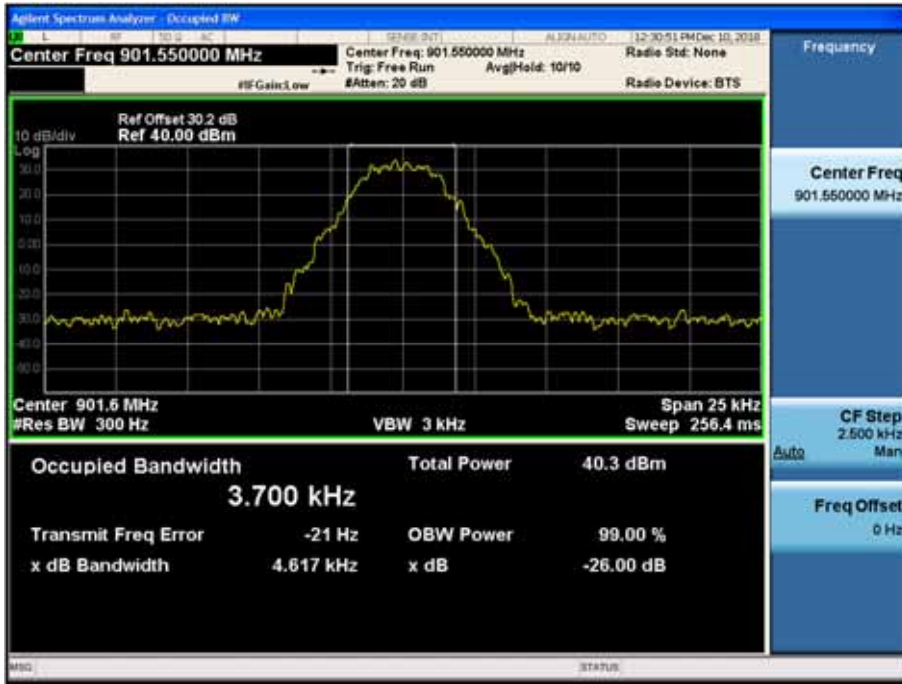

(4K00F1E, 4K00F1D, 4K00F7W _ 940.55 MHz)_High



(4K00F1E, 4K00F1D, 4K00F7W _ 806.05 MHz)_ Low

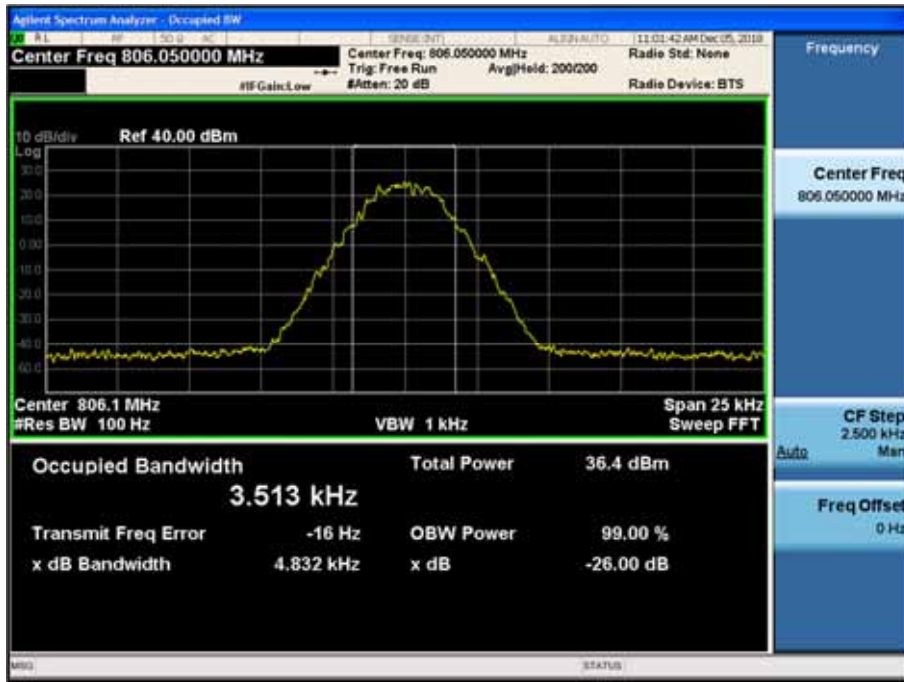

(4K00F1E, 4K00F1D, 4K00F7W _ 851.05 MHz)_ Low

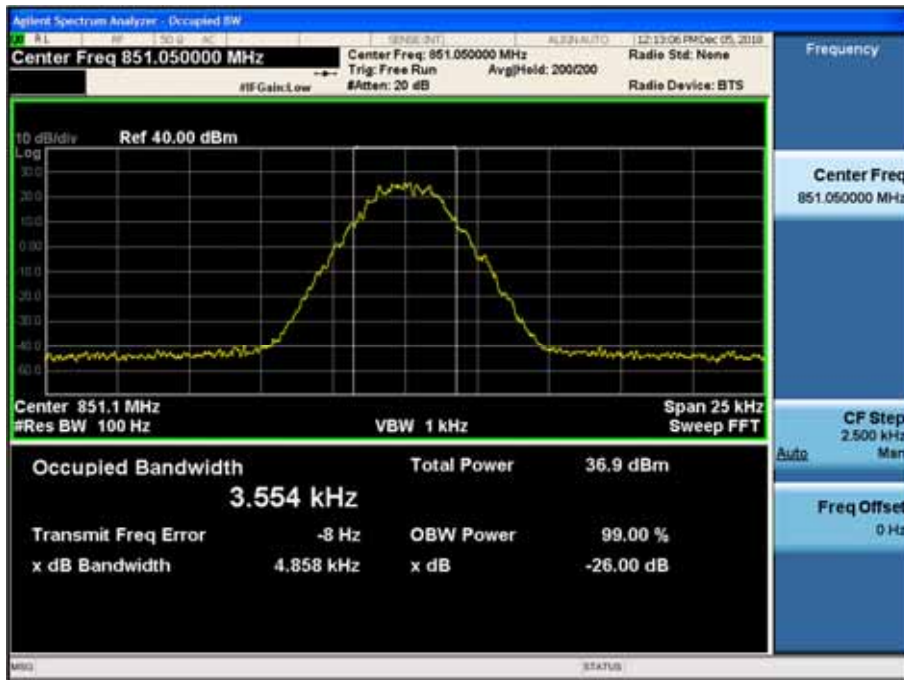

(4K00F1E, 4K00F1D, 4K00F7W _ 868.95 MHz)_ Low

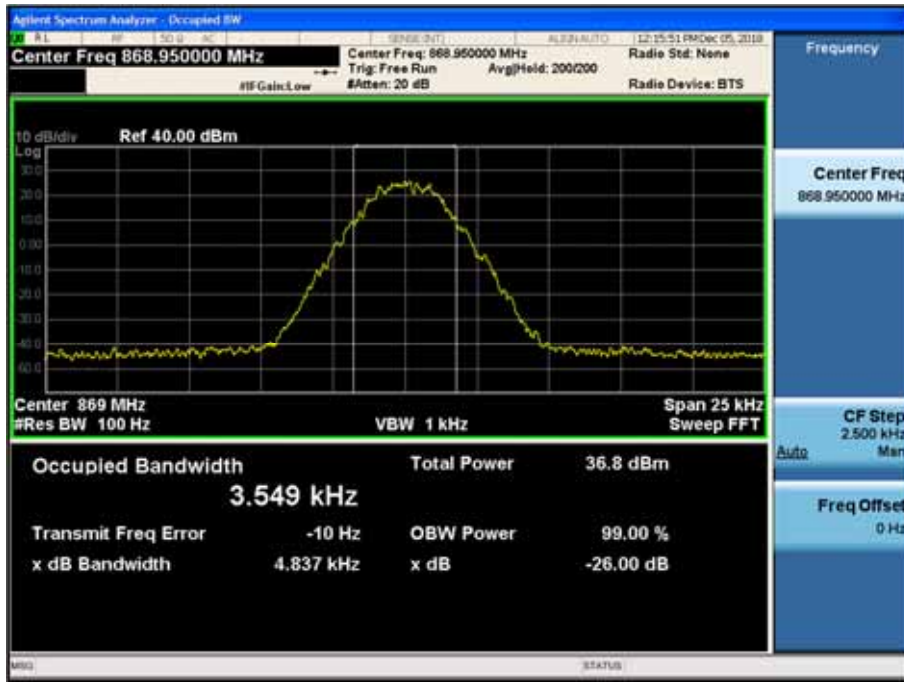

(4K00F1E, 4K00F1D, 4K00F7W _ 896.05 MHz)_ Low

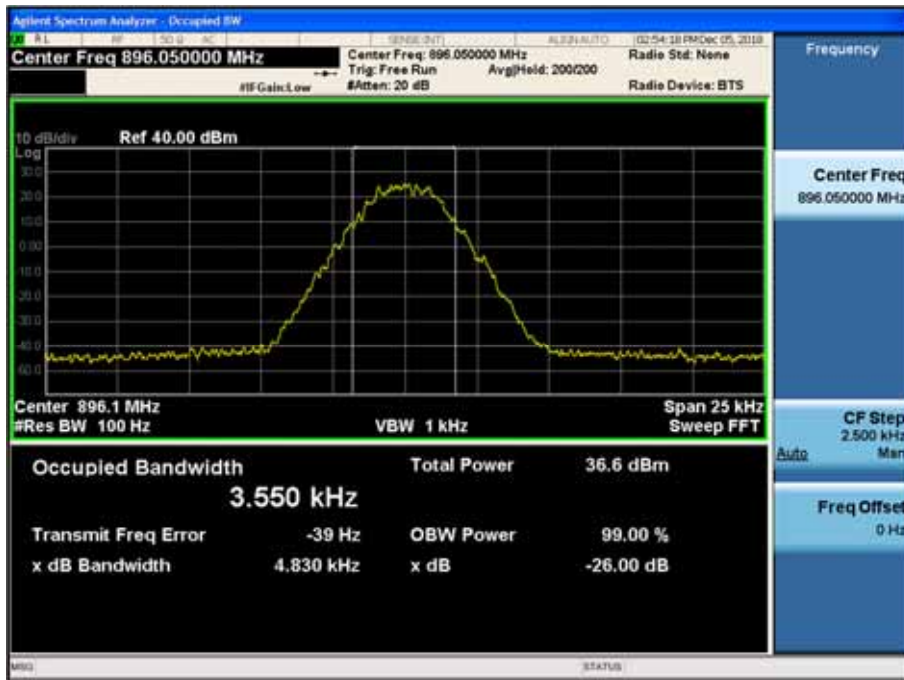

(4K00F1E, 4K00F1D, 4K00F7W _ 900.95 MHz)_Low

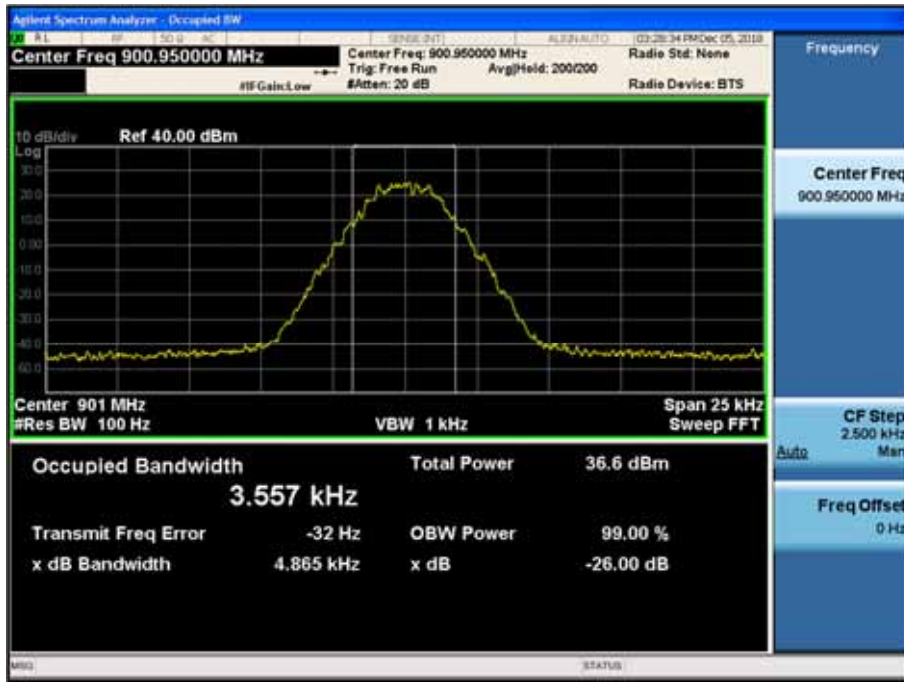

(4K00F1E, 4K00F1D, 4K00F7W _ 939.95 MHz)_Low

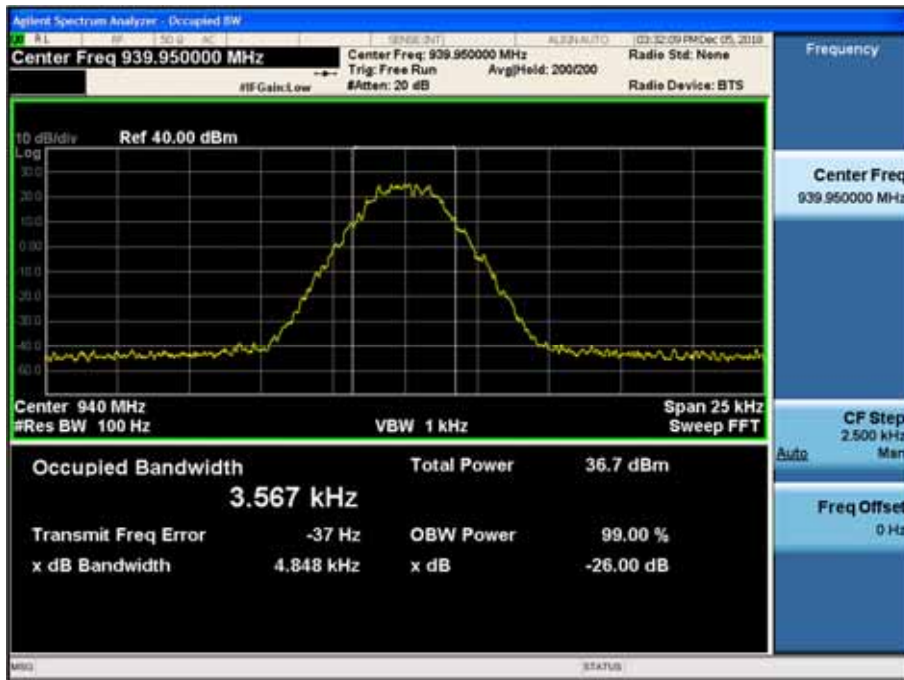

(4K00F1E, 4K00F1D, 4K00F7W _ 901.55 MHz)_Low



(4K00F1E, 4K00F1D, 4K00F7W _ 940.55 MHz)_Low

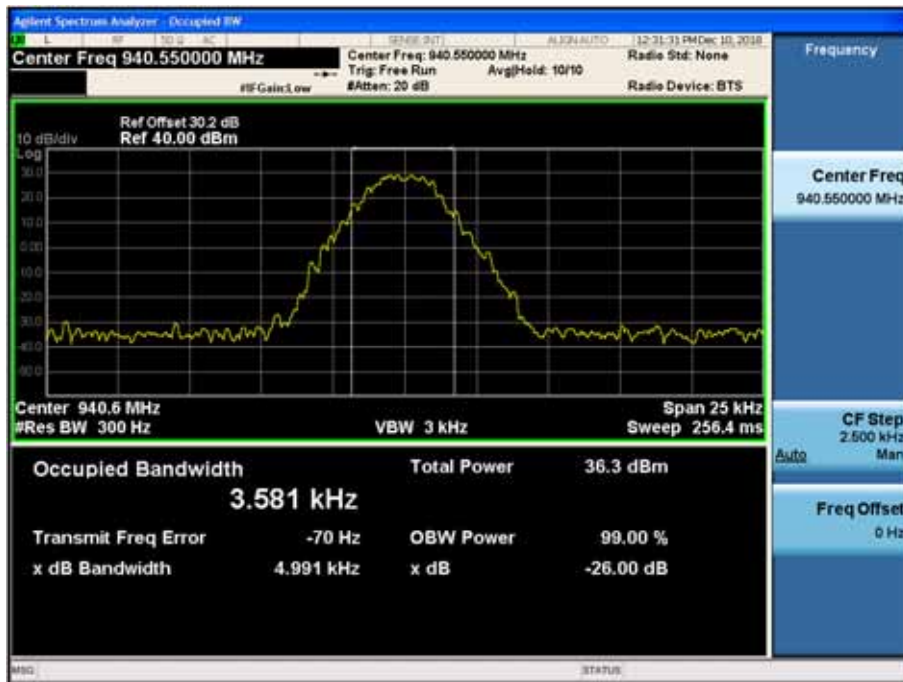

(4K00F2D _ 806.05 MHz)_ High



(4K00F2D _ 851.05 MHz)_ High

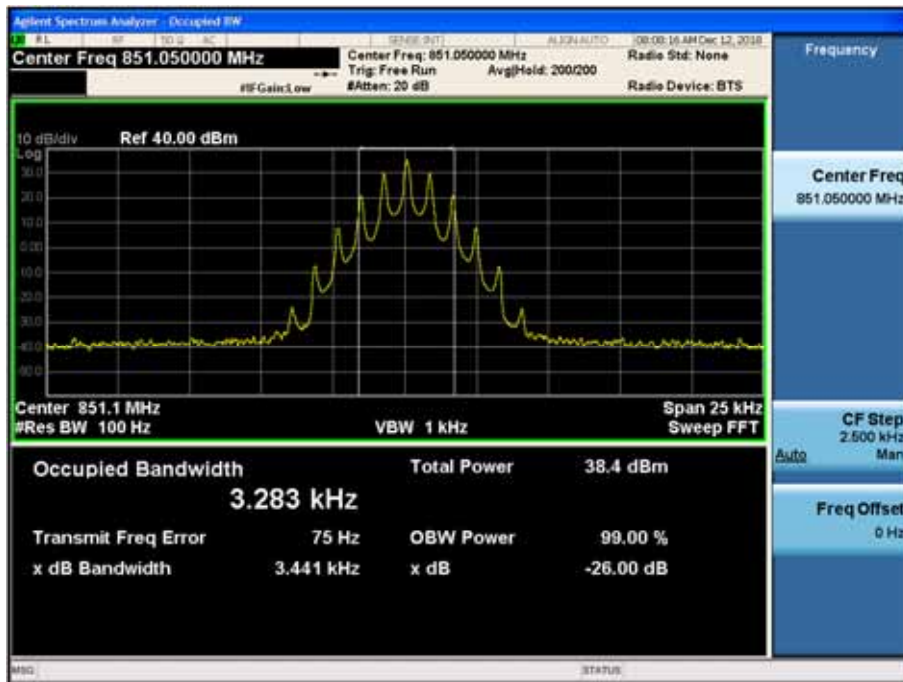

(4K00F2D _ 868.95 MHz)_ High

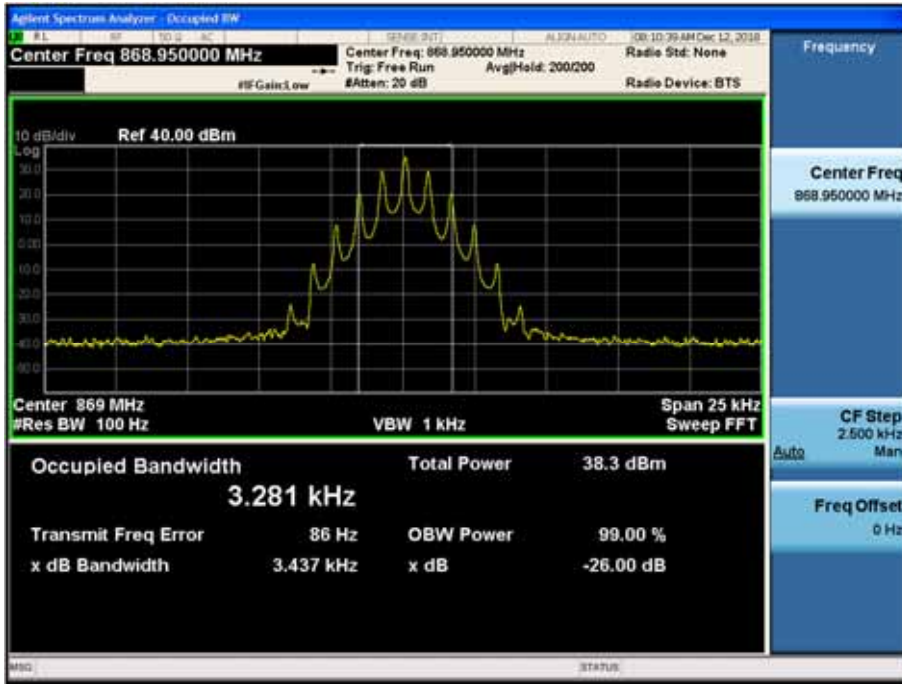

(4K00F2D _ 896.05 MHz)_ High



(4K00F2D _ 900.95 MHz)_ High



(4K00F2D _ 939.95 MHz)_ High

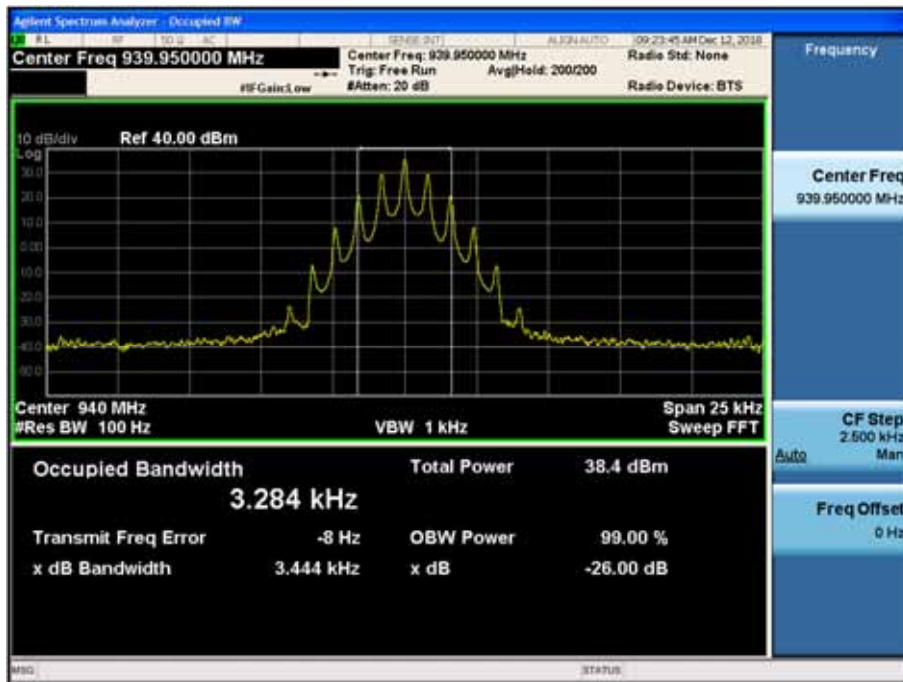

(4K00F2D _ 901.55 MHz)_ High

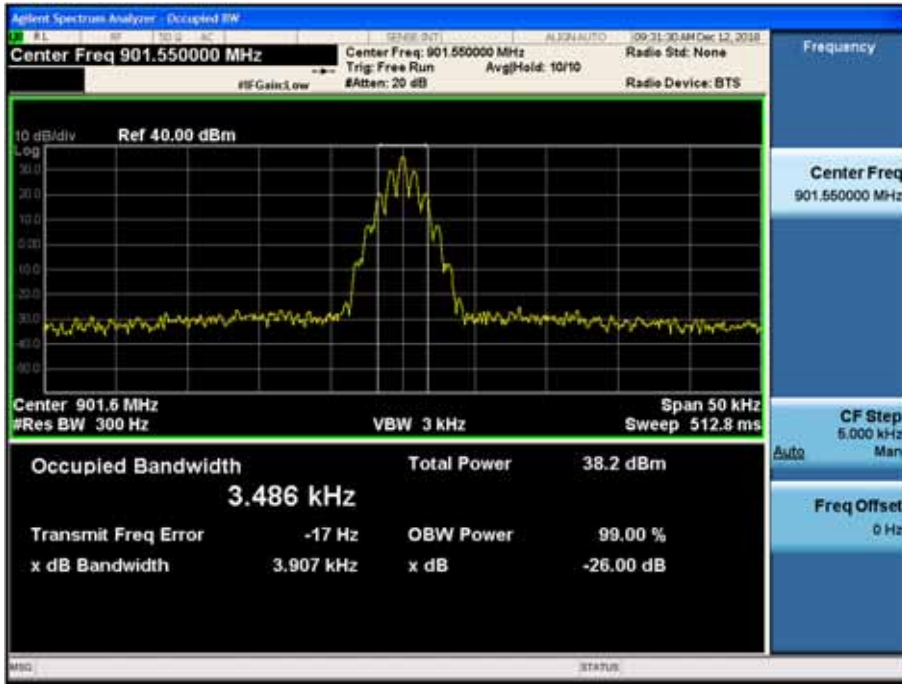

(4K00F2D _ 940.55 MHz)_ High



(4K00F2D _ 806.05 MHz)_ Low



(4K00F2D _ 851.05 MHz)_ Low



(4K00F2D _ 868.95 MHz)_ Low



(4K00F2D _ 896.05 MHz)_ Low

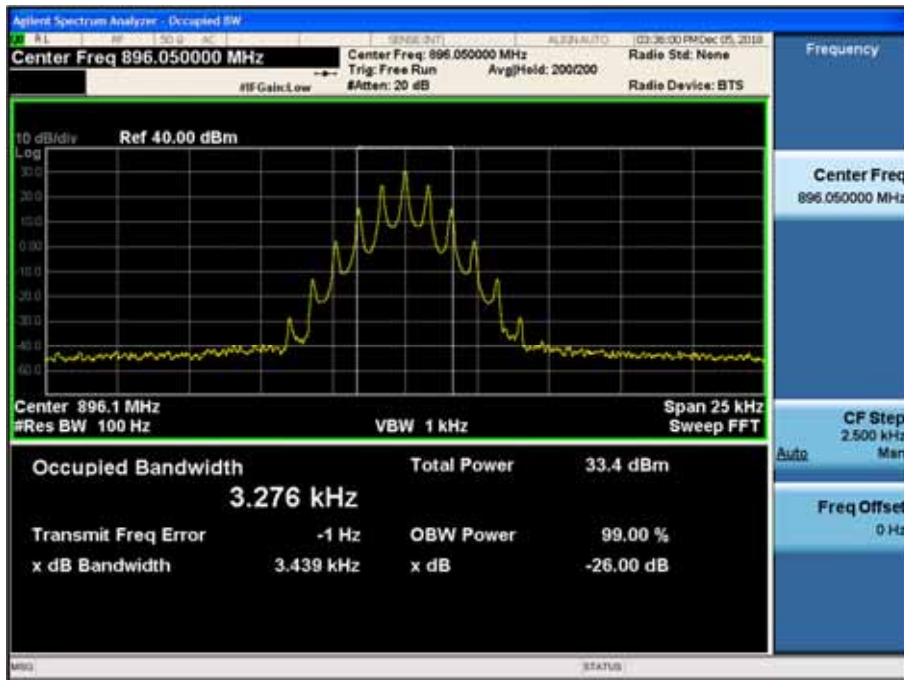

(4K00F2D _ 900.95 MHz)_Low



(4K00F2D _ 939.95 MHz)_Low

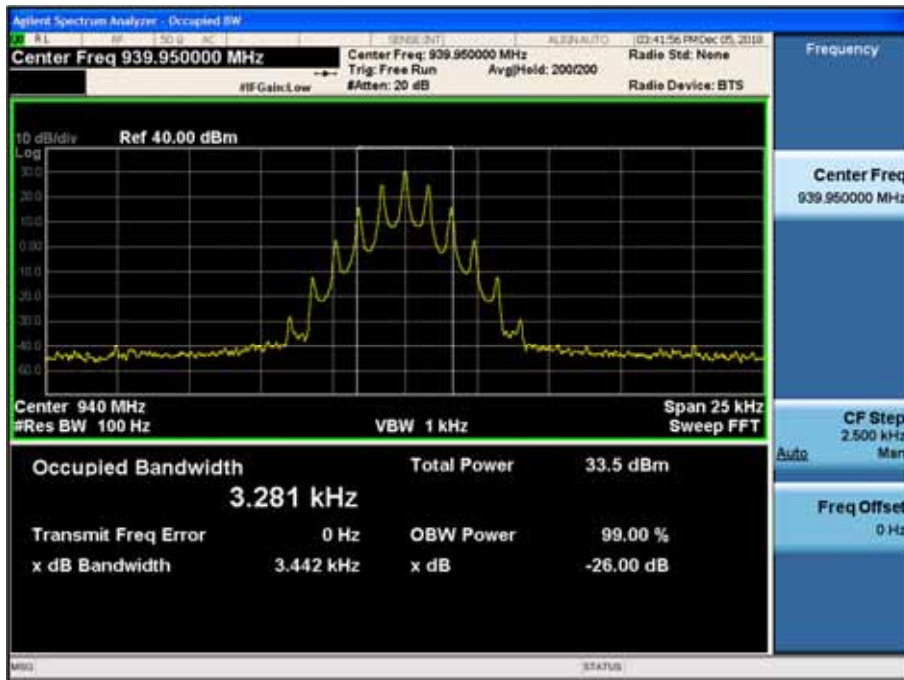

(4K00F2D _ 901.55 MHz)_ Low



(4K00F2D _ 940.55 MHz)_ Low



10.4 Modulation Limiting

Definition

Modulation limiting is the transmitter circuit's ability to limit the transmitter from producing deviations in excess of a rated system deviation.

TEST CONFIGURATION

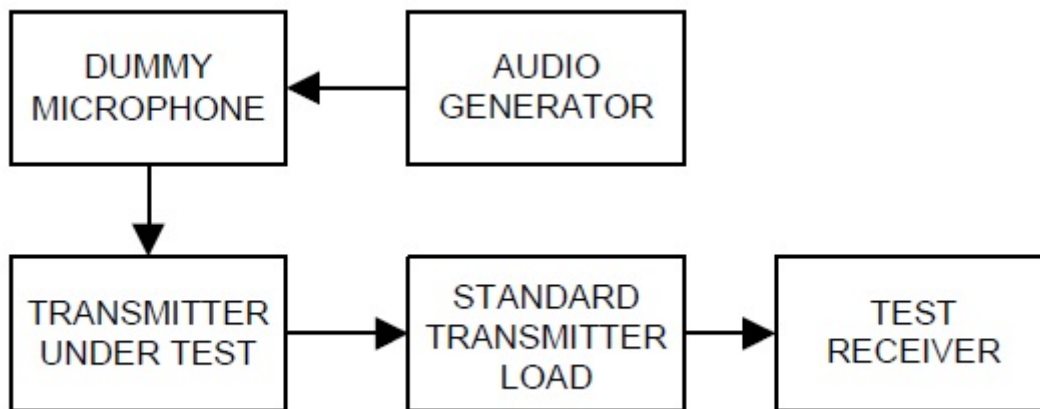

TEST PROCEDURE

According to 2.2.3 in TIA-603-E Standard.

- a) Connect the equipment as illustrated.
- b) Adjust the transmitter per the manufacturer's procedure for full rated system deviation.
- c) Set the test receiver to measure peak positive deviation.
Set the audio bandwidth for ≤ 0.25 Hz to $\geq 15,000$ Hz.
Turn the de-emphasis function off.
- d) Apply a 1000 Hz modulating signal to the transmitter from the audio frequency generator, and adjust the level obtain 60% of full rated system deviation.
- e) Increase the level form the audio frequency generator by 20 dB in one step(rise time between the 10% and 90% points shall be 0.1 second maximum).
- f) Measure both the instantaneous and steady-state deviation at and after the time of increasing the audio input level.
- g) With the level from the audio frequency generator held constant at the level obtained in step e), Slowly vary the audio frequency from 300 Hz to 3000 Hz and observe the steady-state deviation. Record the maximum deviation.
- h) Set the test receiver to measure peak negative deviation and repeat steps d) through g).
- i) The values recorded in steps g) and h) are the modulation limiting.

TEST RESULTS (11K0F3E)

Positive Peaks

11K0F3E_806.05 MHz_HIGH POWER

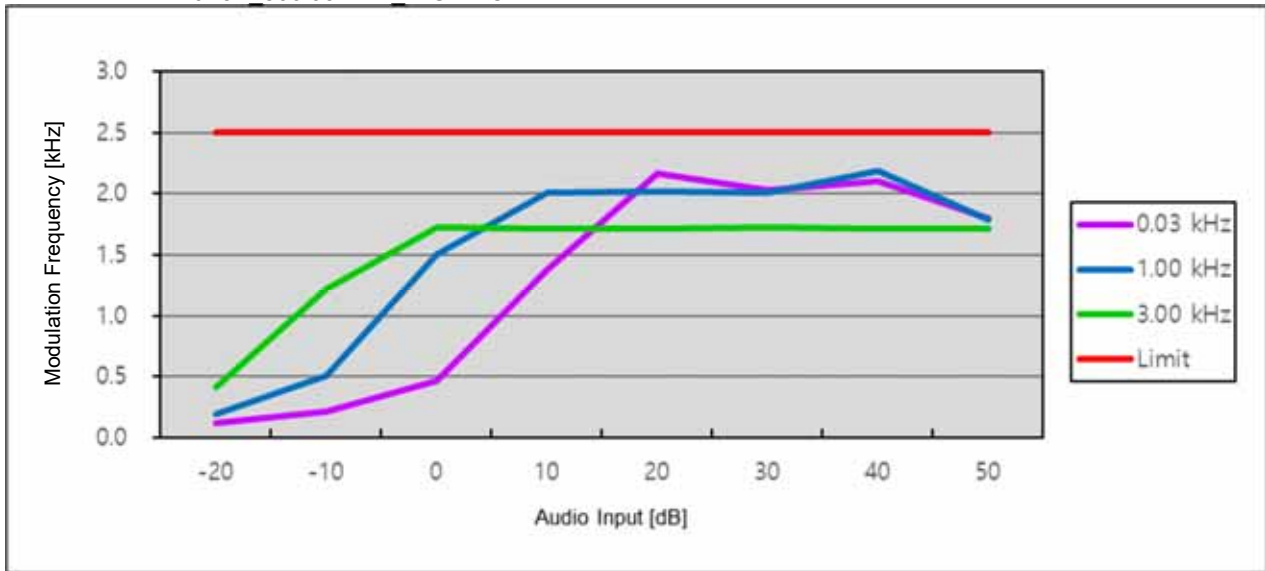

11K0F3E_851.05 MHz_HIGH POWER

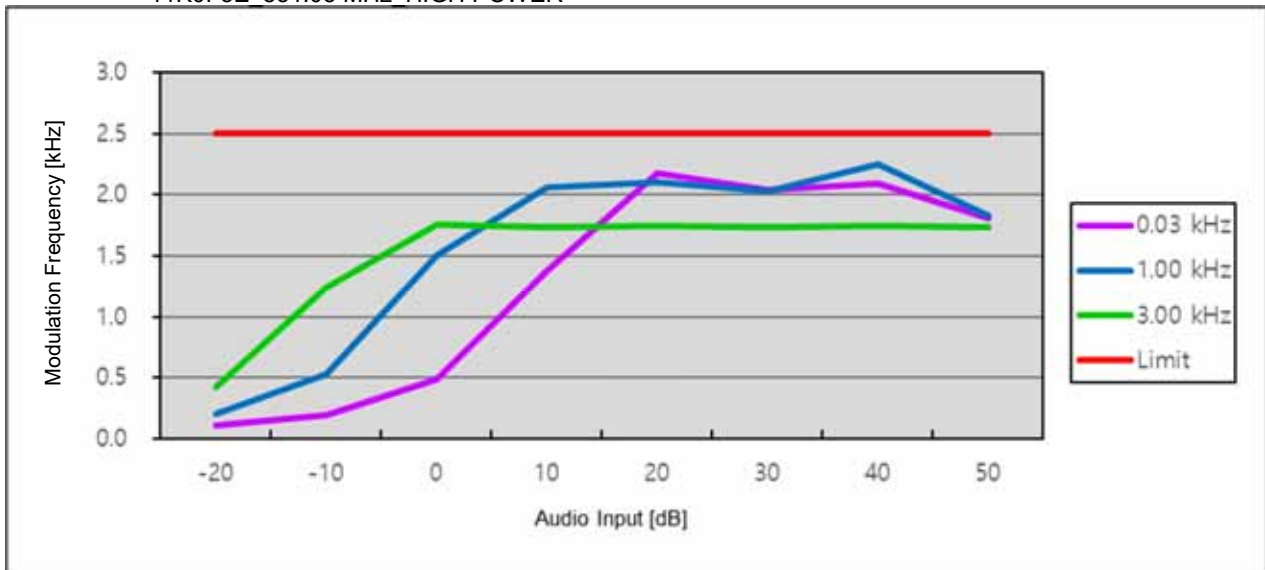

11K0F3E_868.95 MHz_HIGH POWER

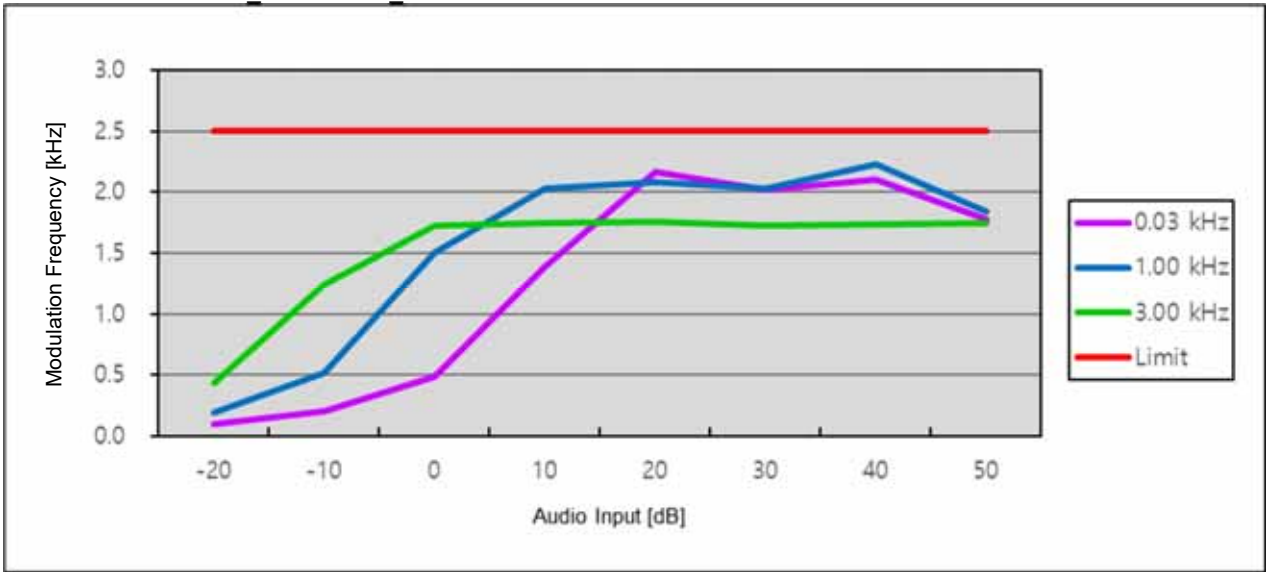

11K0F3E_900.95 MHz_HIGH POWER

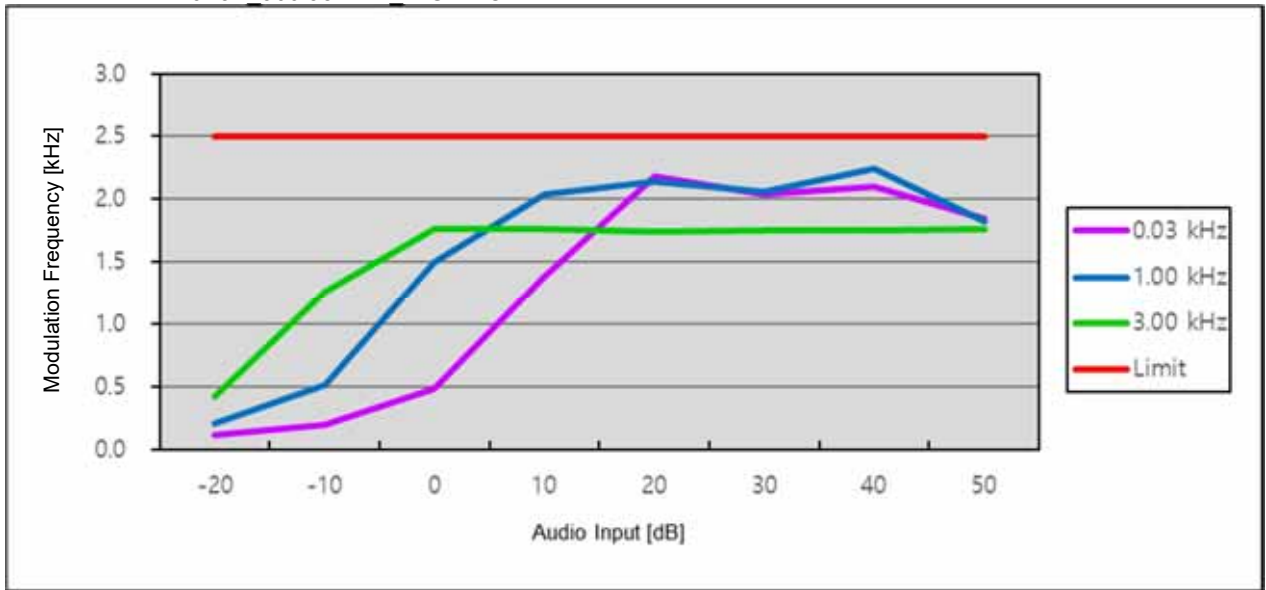

11K0F3E_939.95 MHz_HIGH POWER

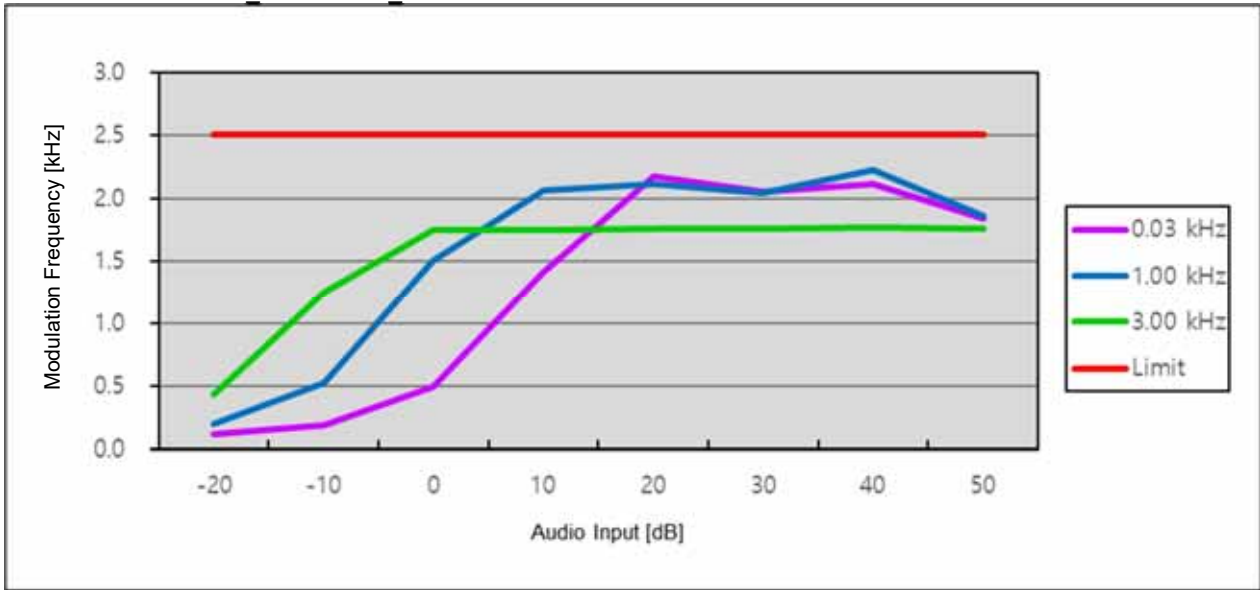

11K0F3E_901.55 MHz_HIGH POWER

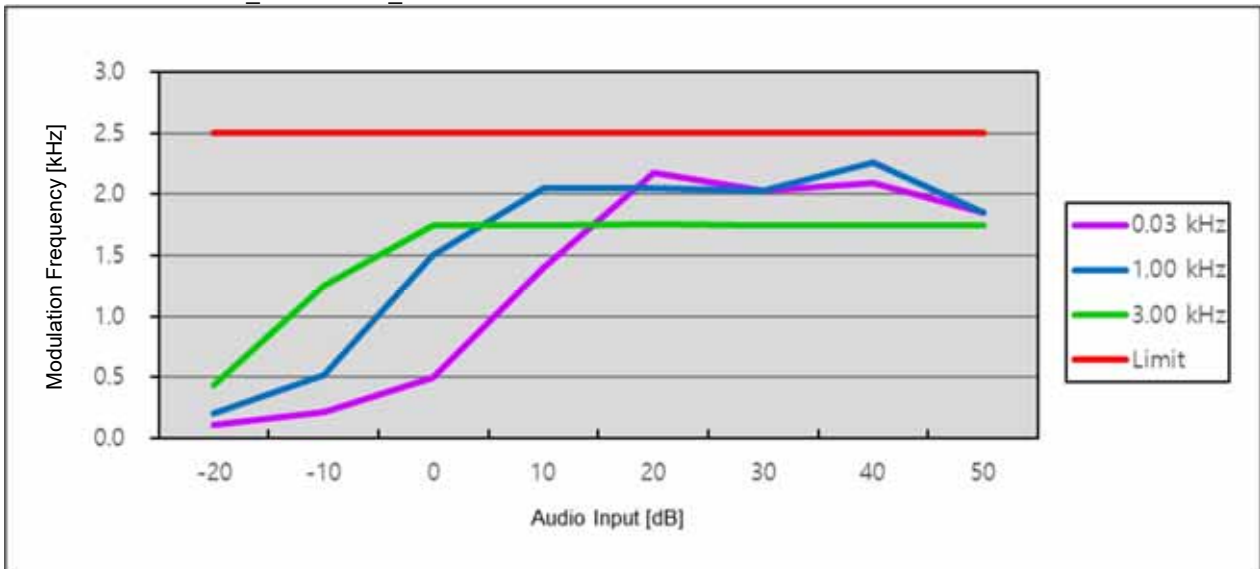

11K0F3E_940.55 MHz_HIGH POWER

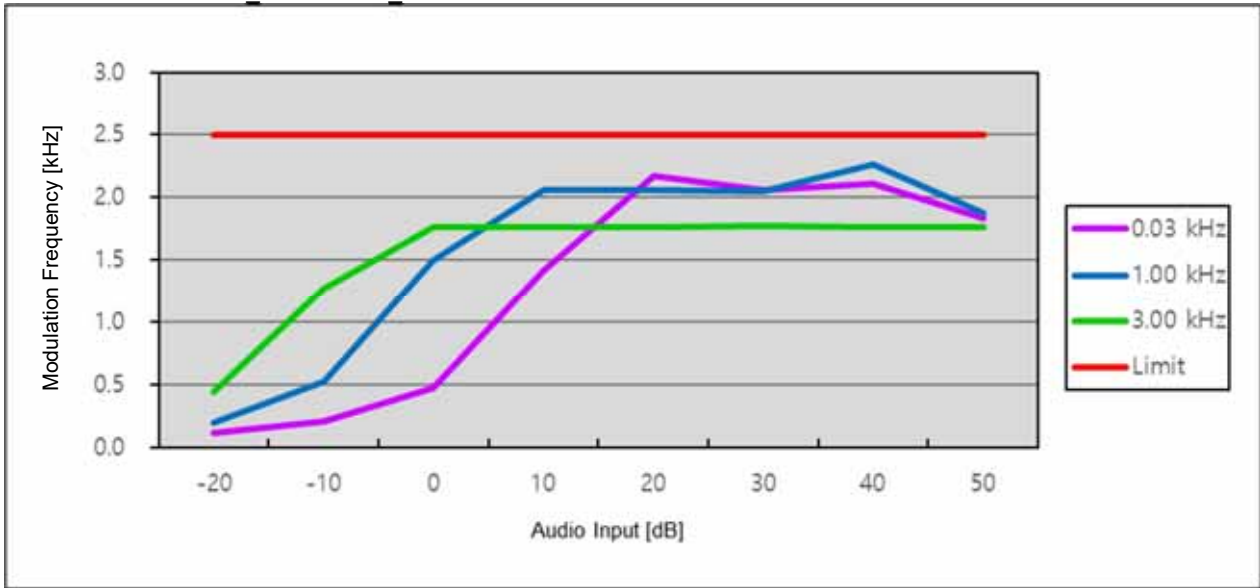

11K0F3E_806.05 MHz_LOW POWER

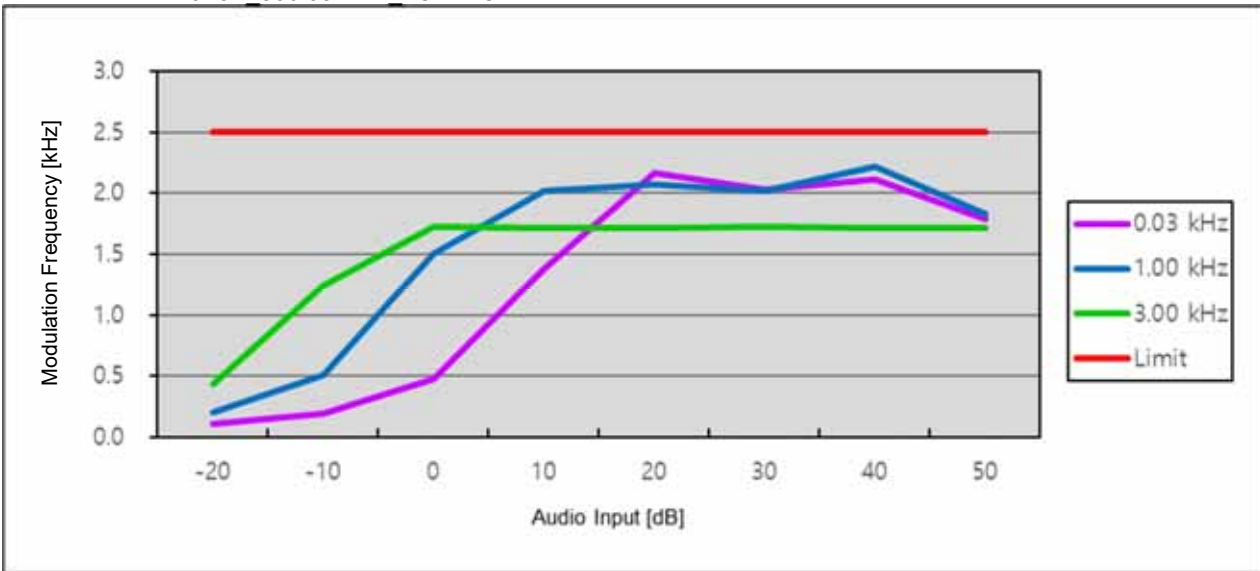

11K0F3E_851.05 MHz_LOW POWER

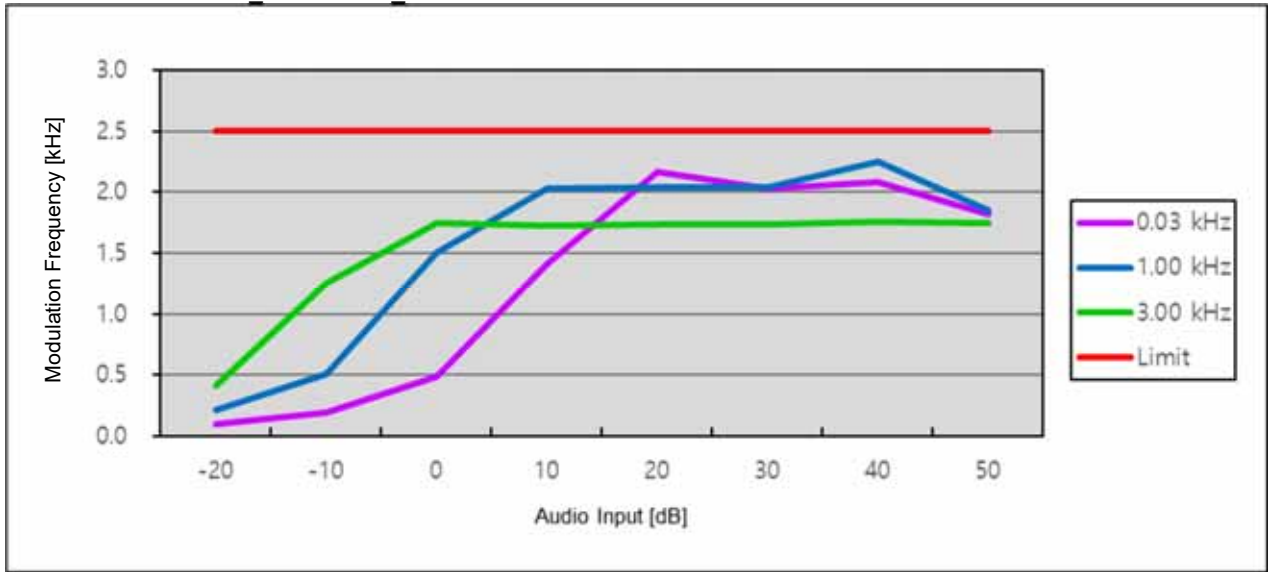

11K0F3E_868.95 MHz_LOW POWER

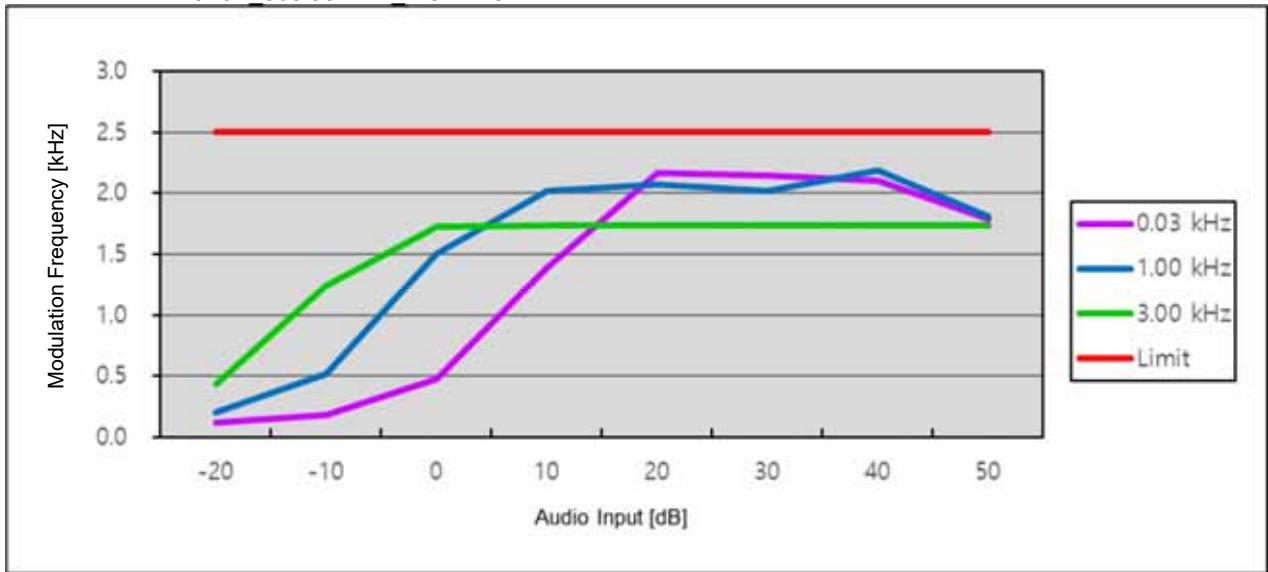

11K0F3E_900.95 MHz_LOW POWER

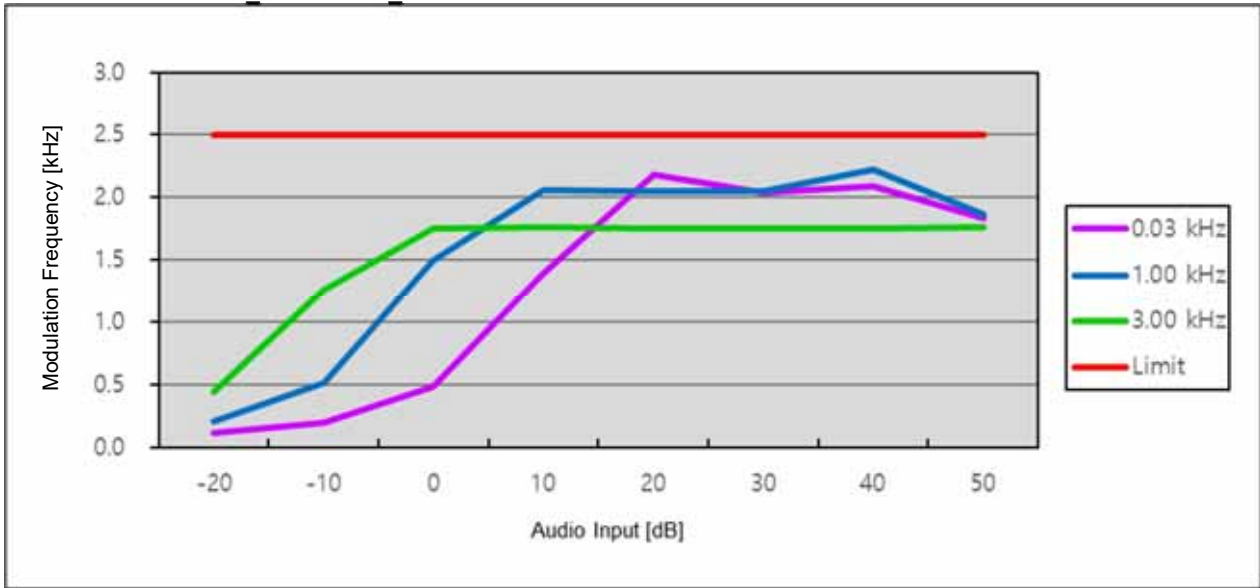

11K0F3E_939.95 MHz_LOW POWER

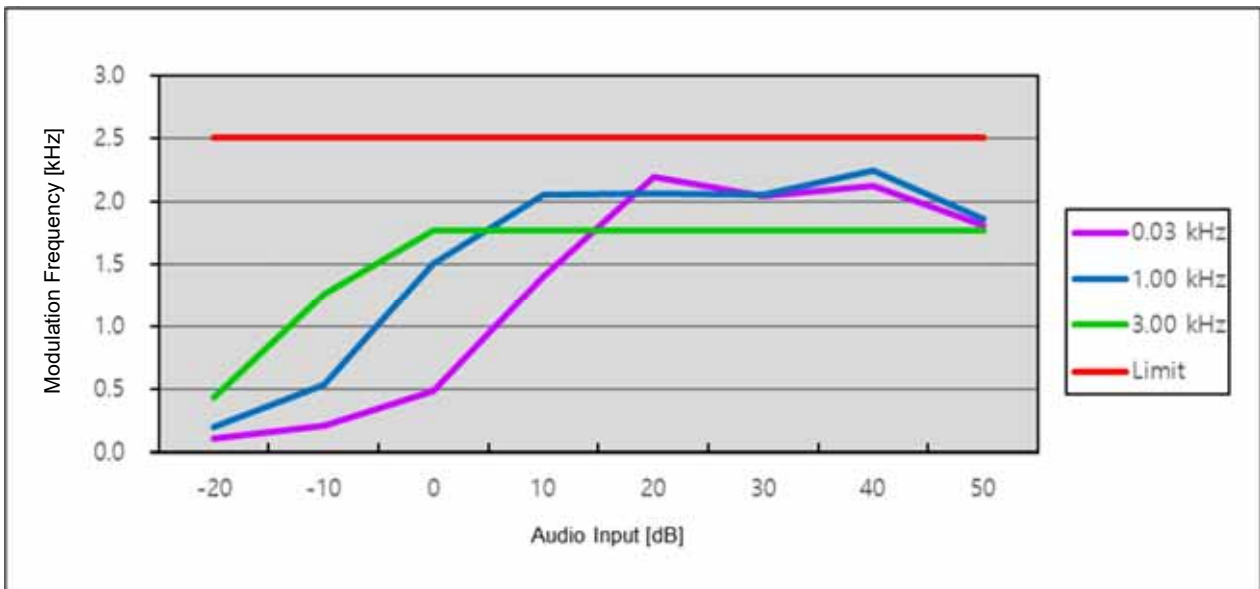

11K0F3E_901.55 MHz_LOW POWER

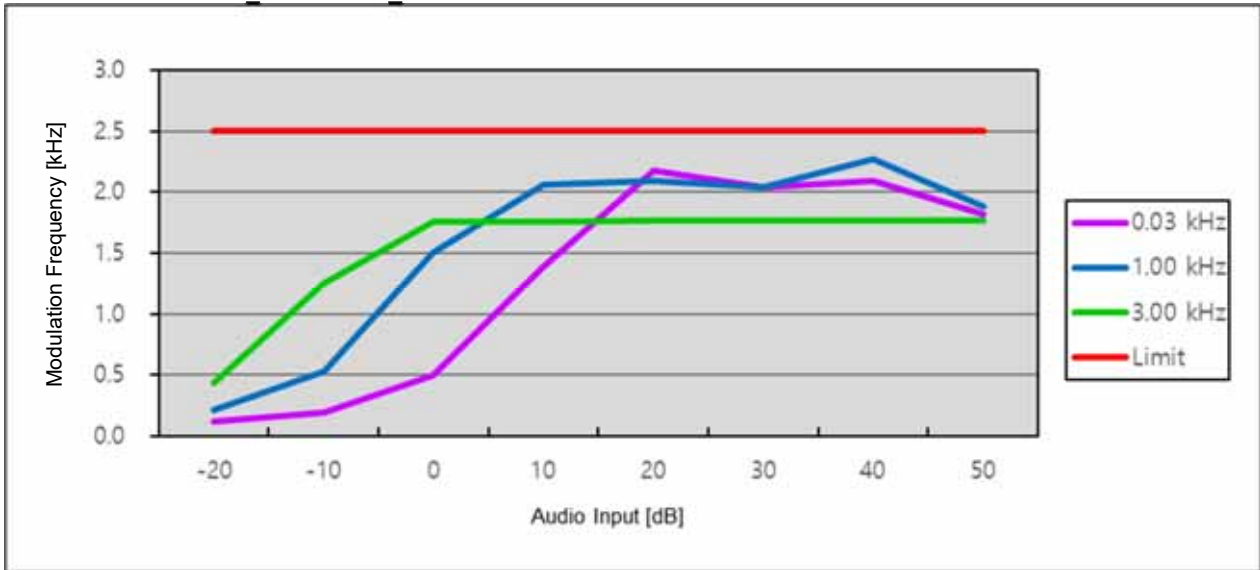

11K0F3E_940.55 MHz_LOW POWER

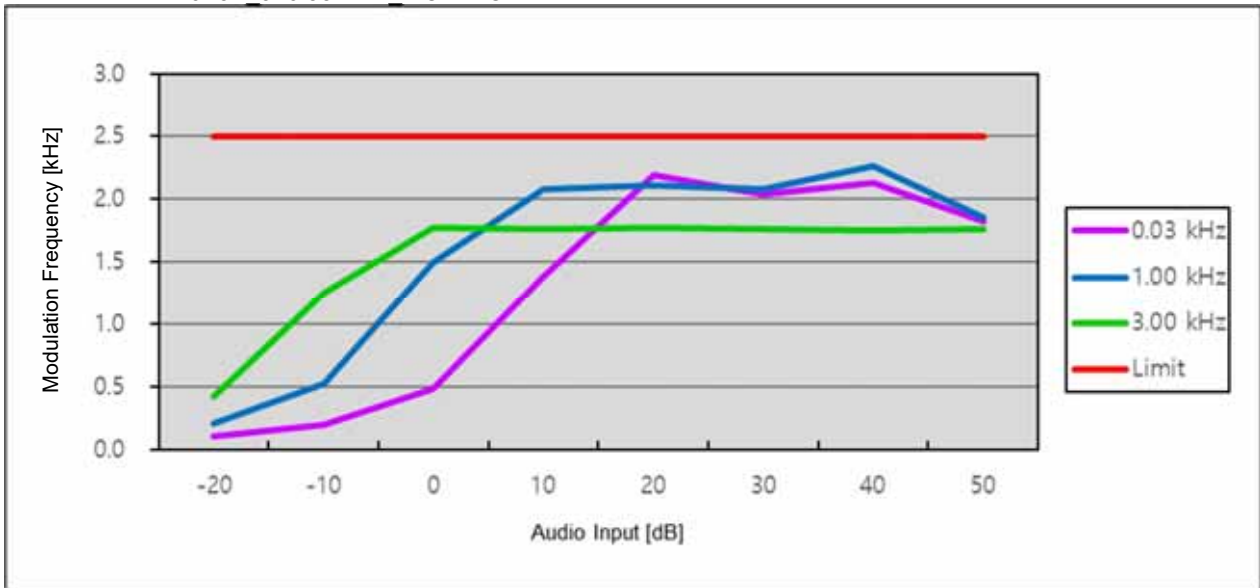

Negative Peaks

11K0F3E_806.05 MHz_HIGH POWER

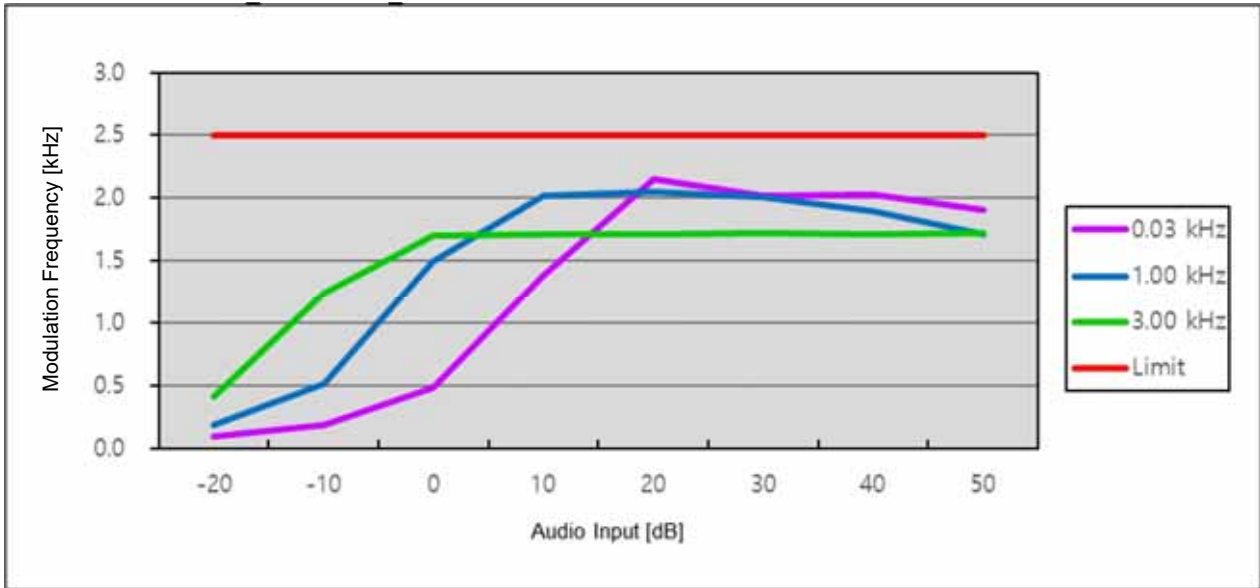

11K0F3E_851.05 MHz_HIGH POWER

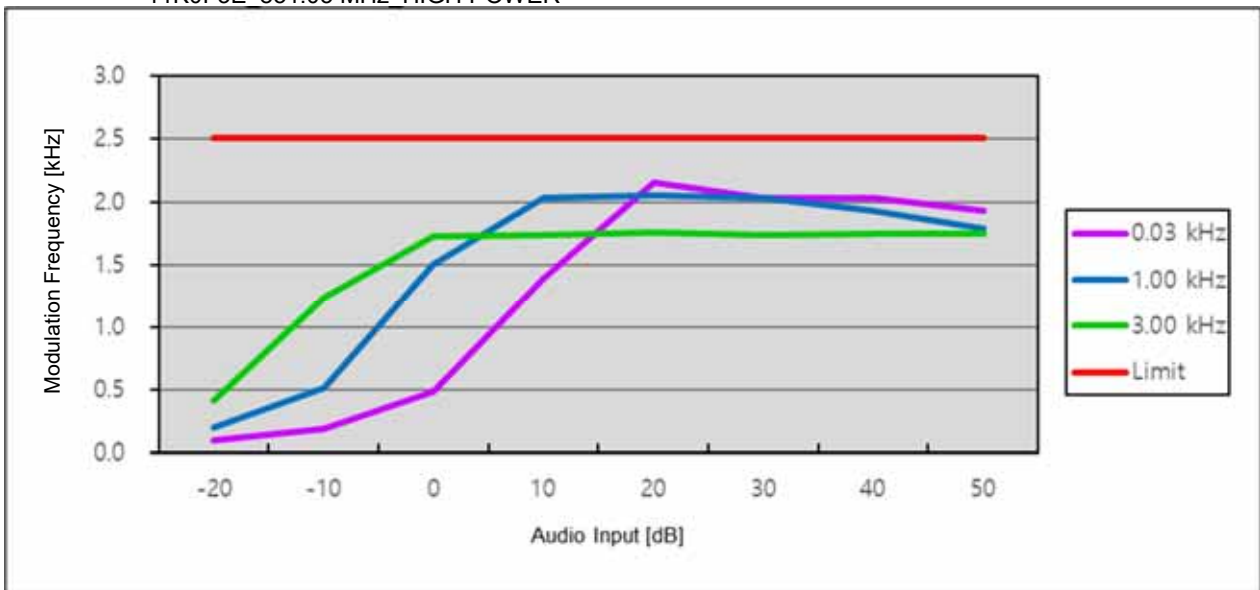

11K0F3E_868.95 MHz_HIGH POWER

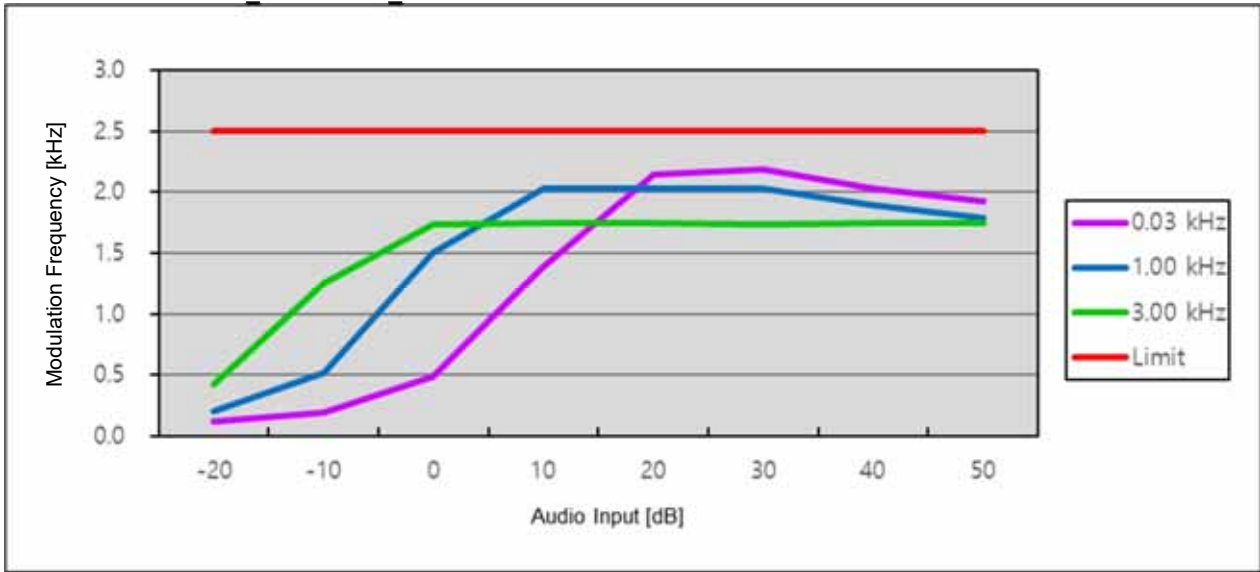

11K0F3E_900.95 MHz_HIGH POWER

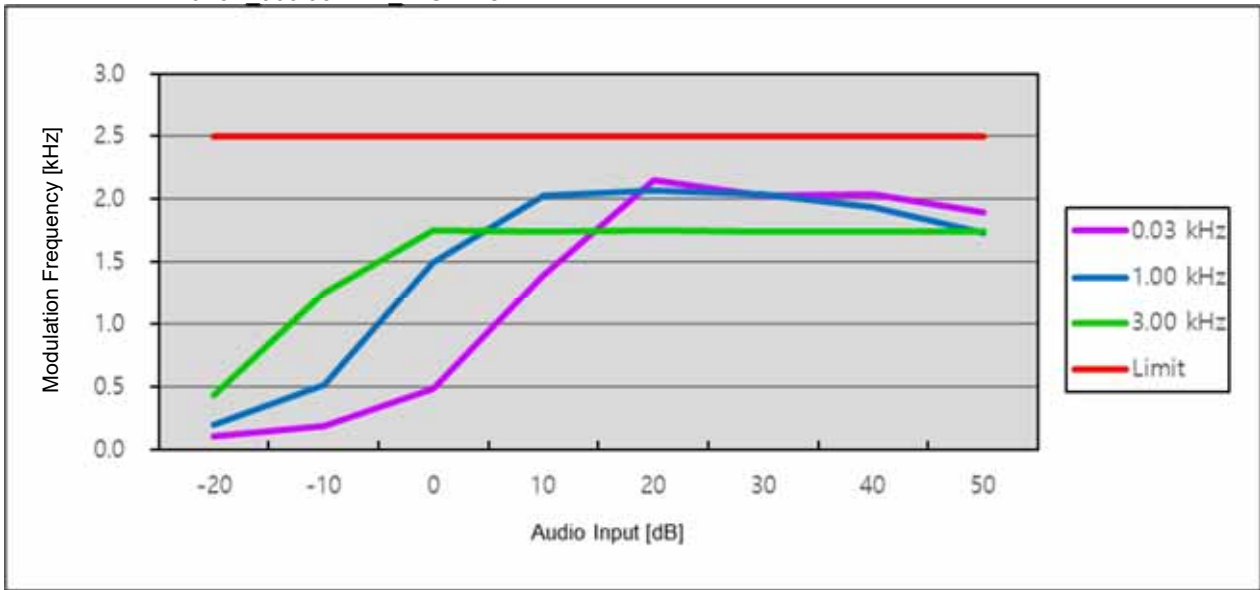

11K0F3E_939.95 MHz_HIGH POWER

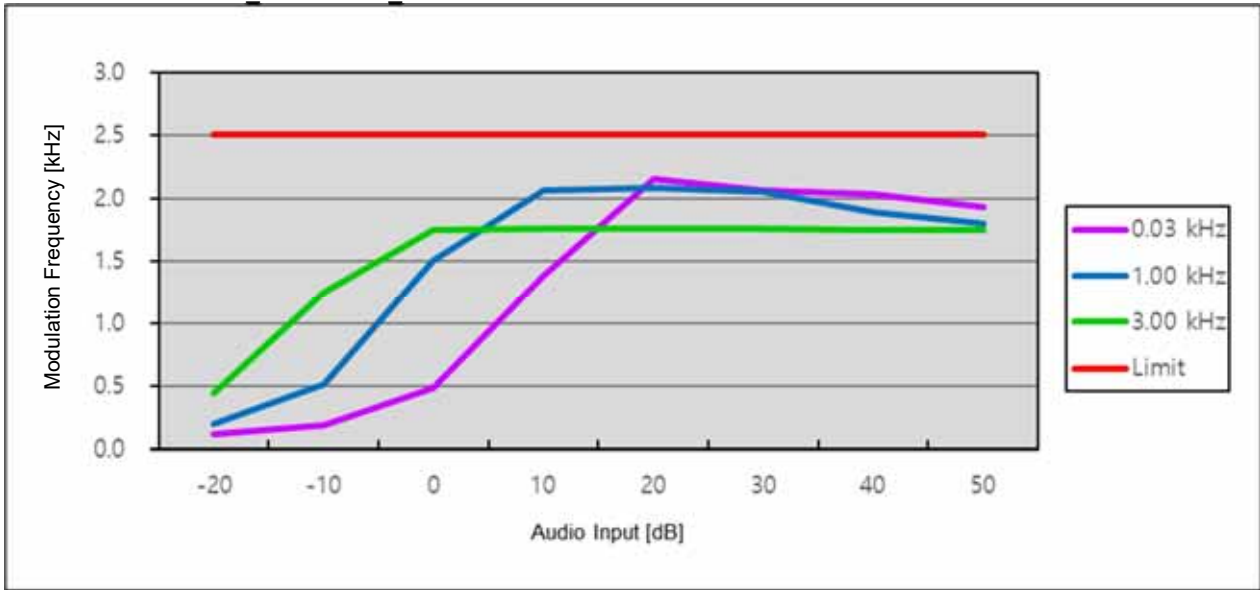

11K0F3E_901.55 MHz_HIGH POWER

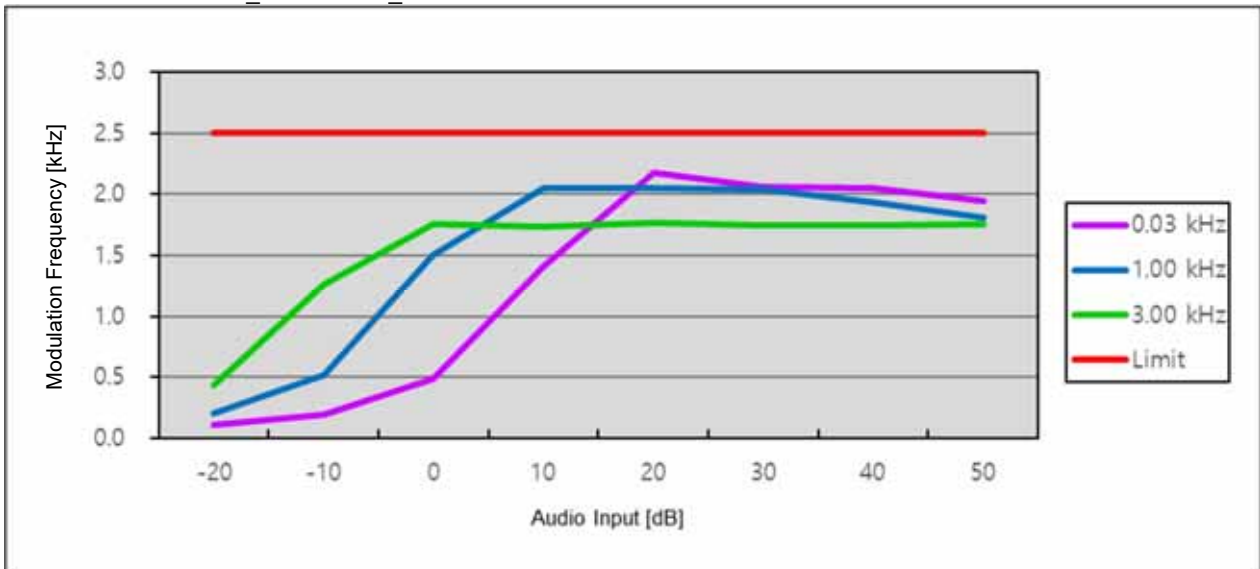

11K0F3E_940.55 MHz_HIGH POWER

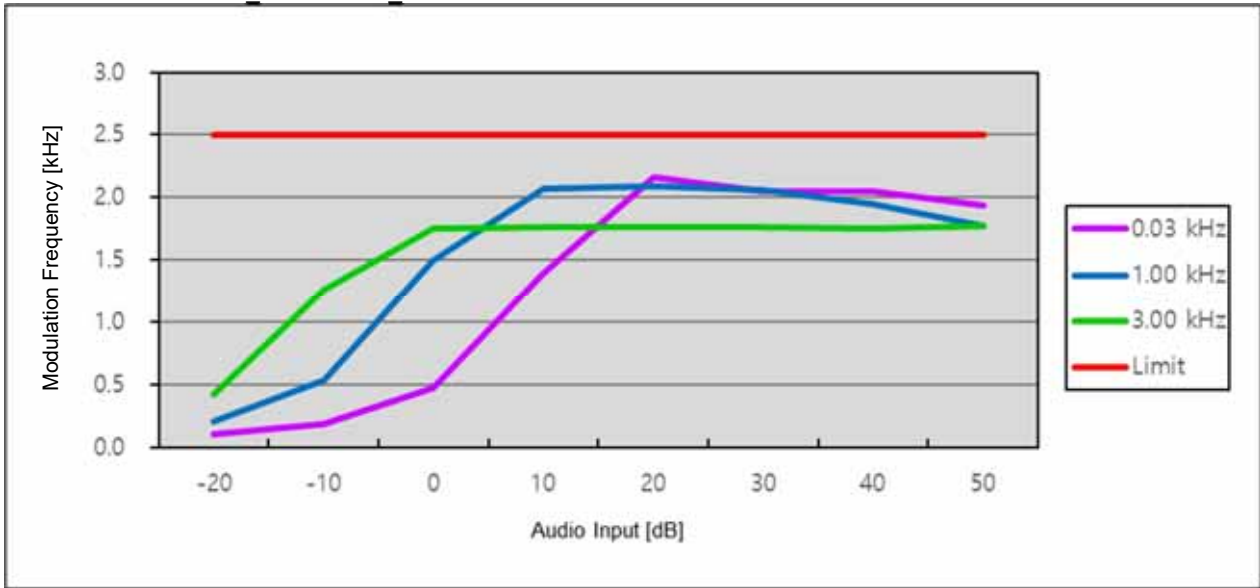

11K0F3E_806.05 MHz_LOW POWER

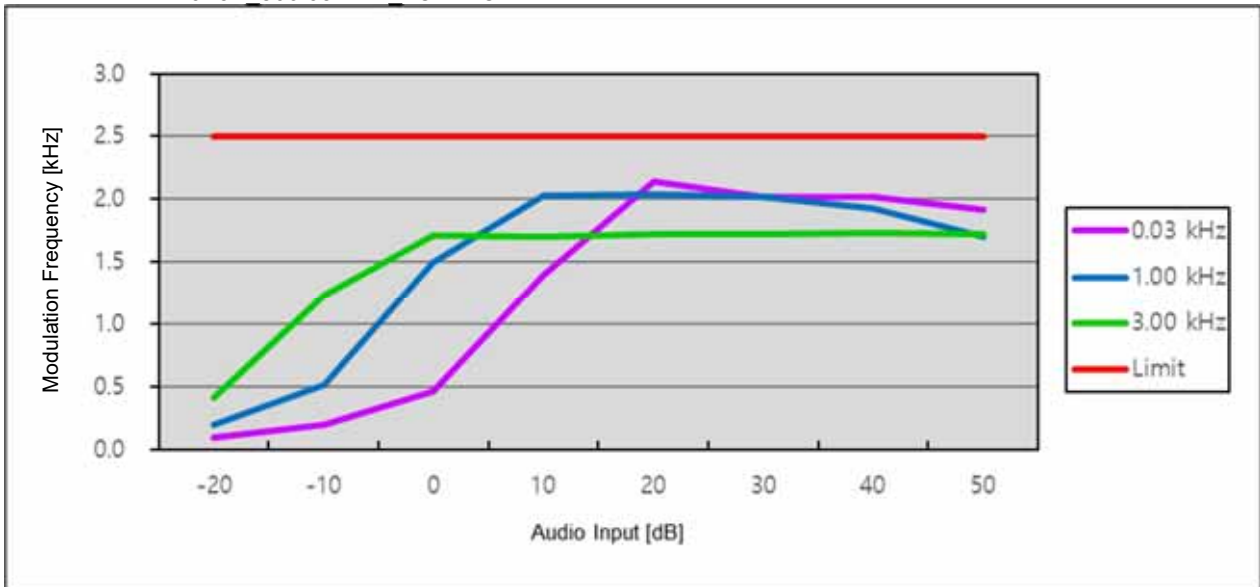

11K0F3E_851.05 MHz_LOW POWER

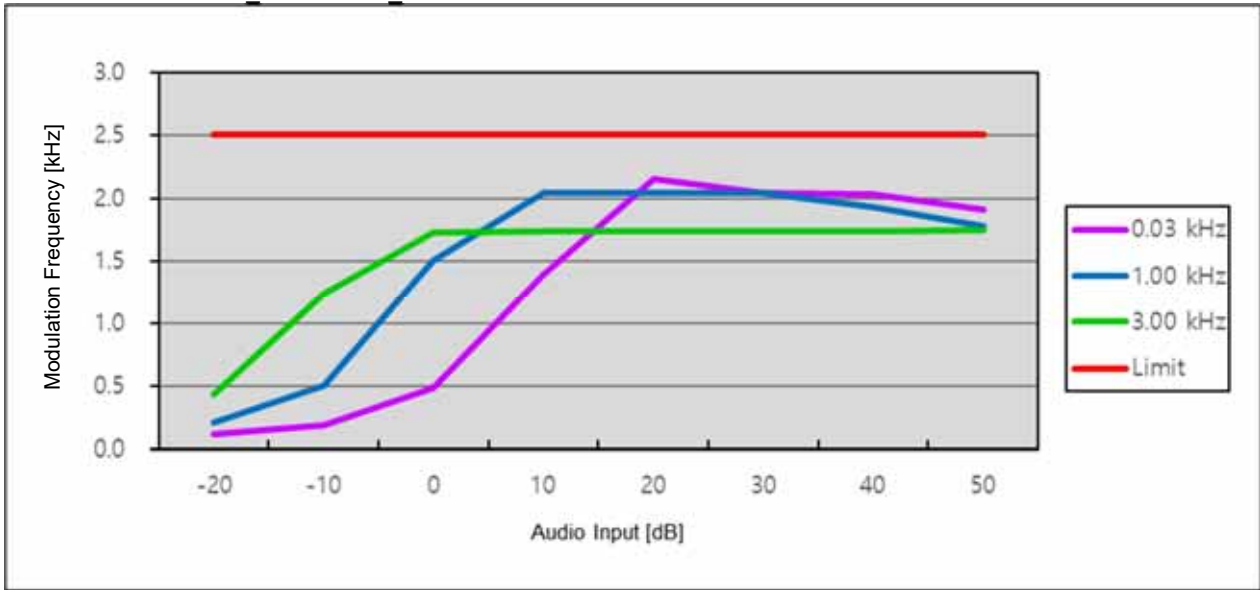

11K0F3E_868.95 MHz_LOW POWER

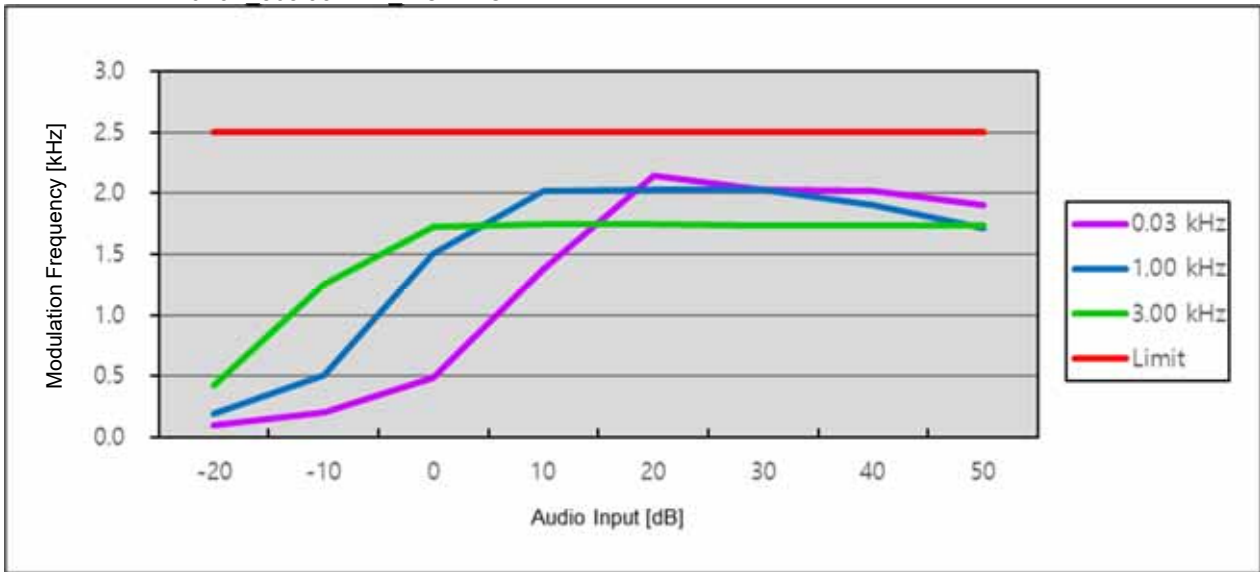

11K0F3E_900.95 MHz_LOW POWER

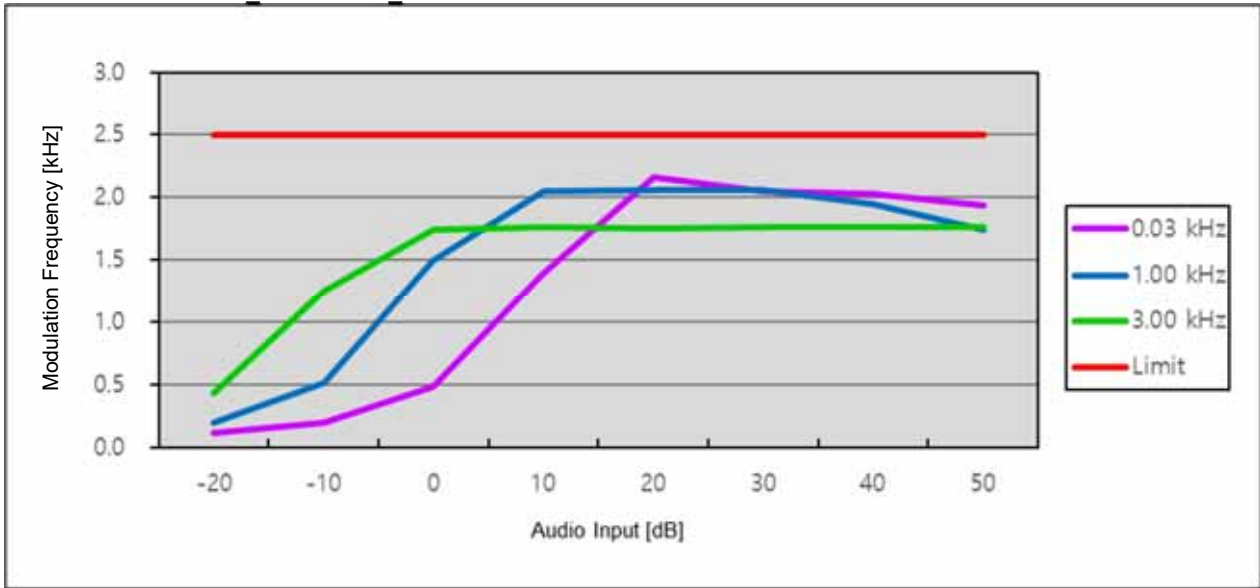

11K0F3E_939.95 MHz_LOW POWER

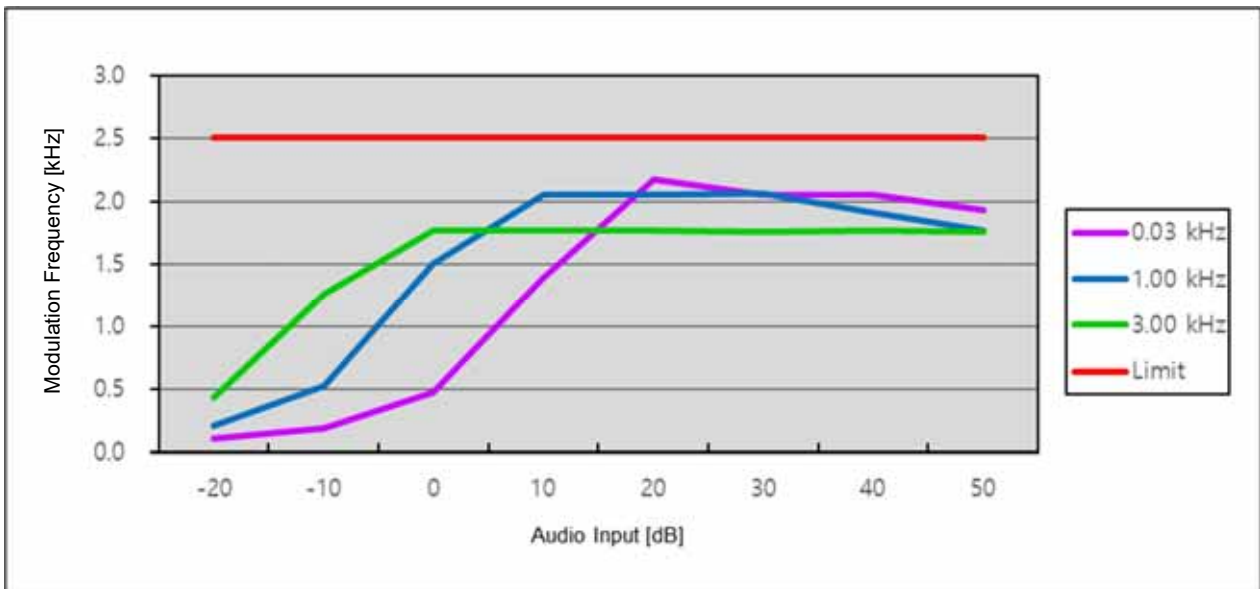

11K0F3E_901.55 MHz_LOW POWER

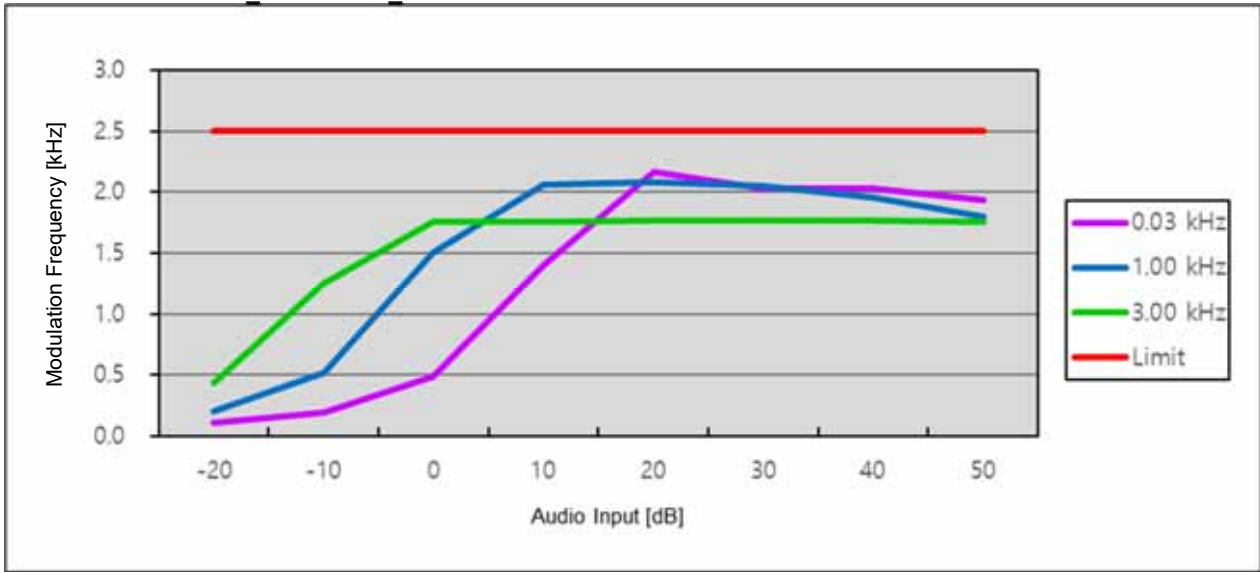

11K0F3E_940.55 MHz_LOW POWER

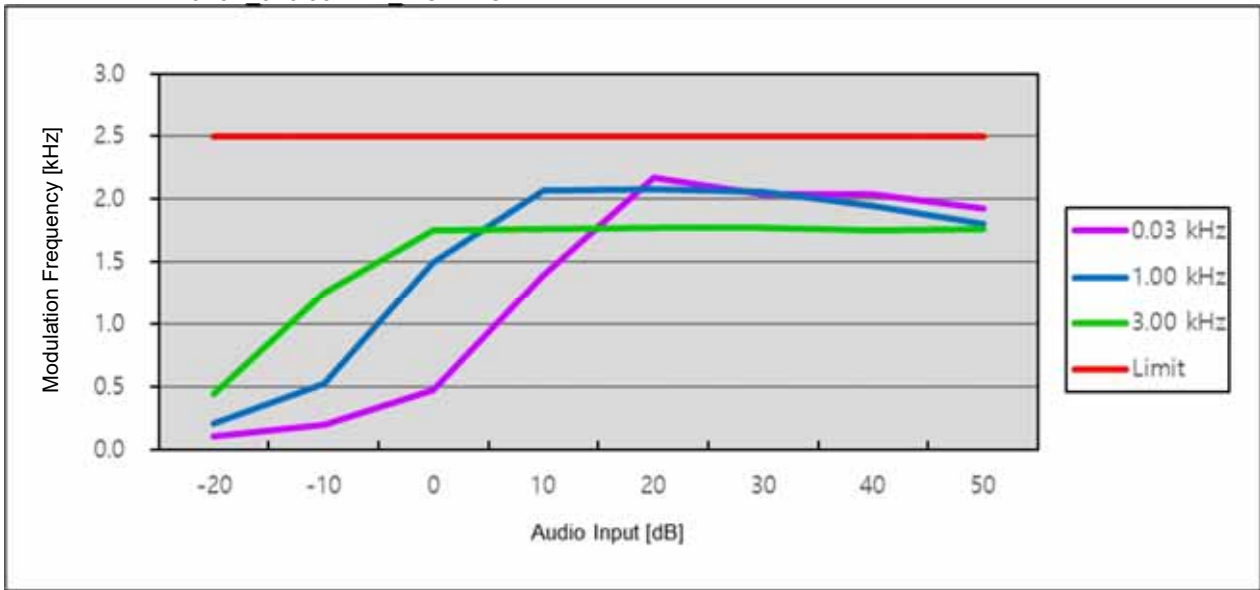

TEST RESULTS (14K0F3E)

Positive Peaks

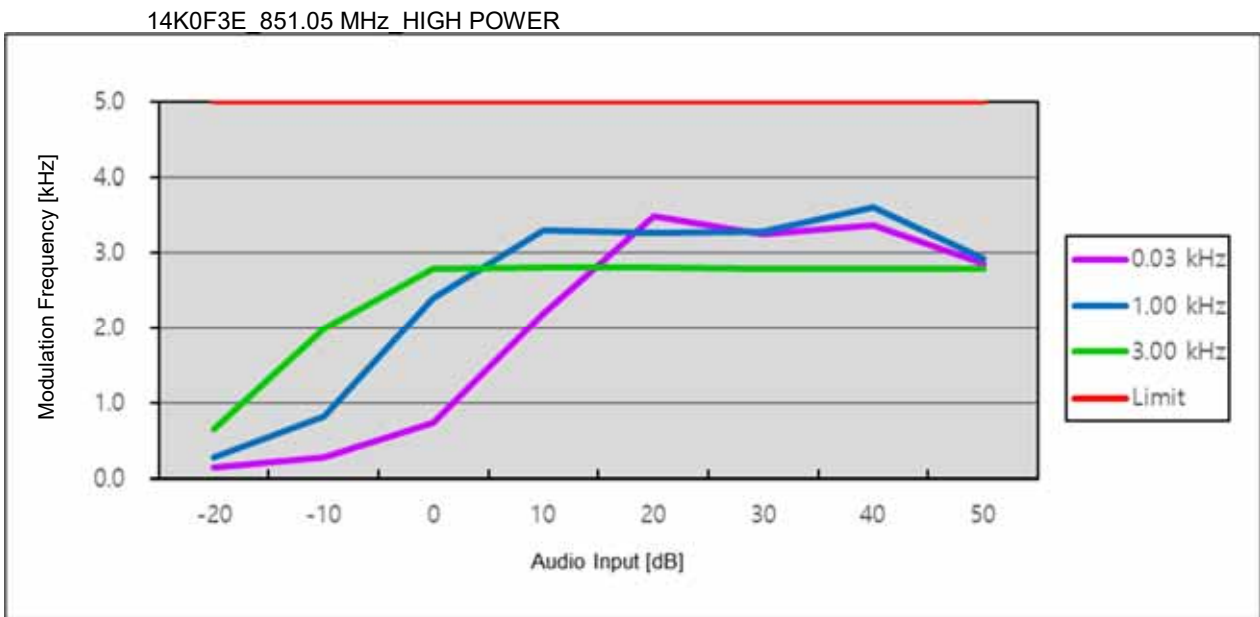
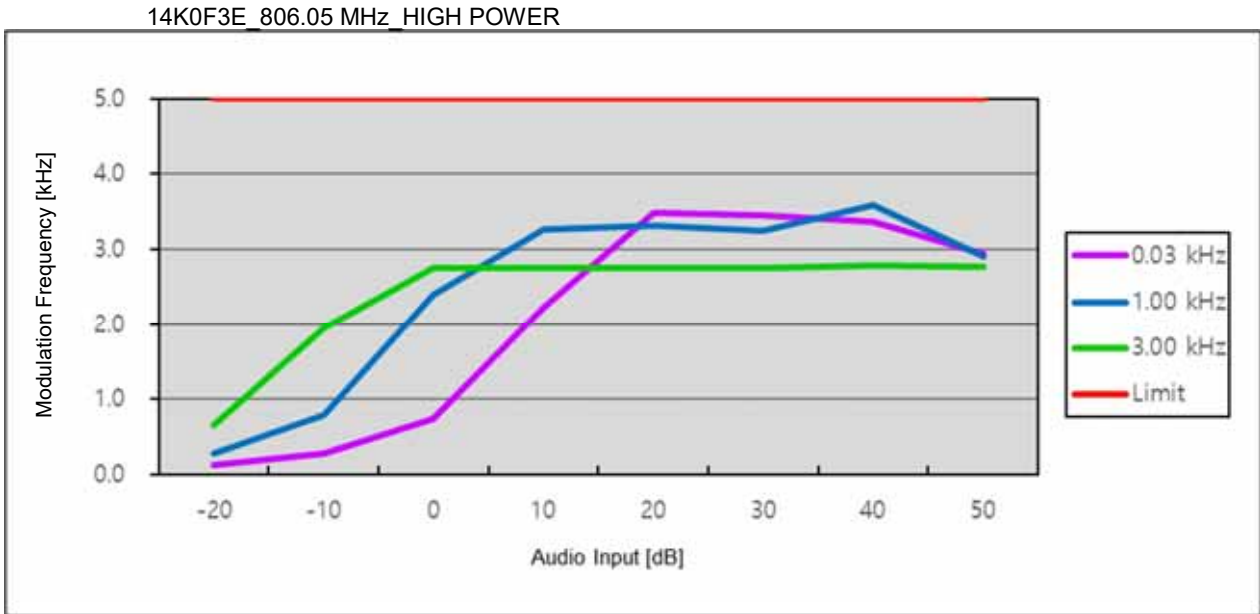

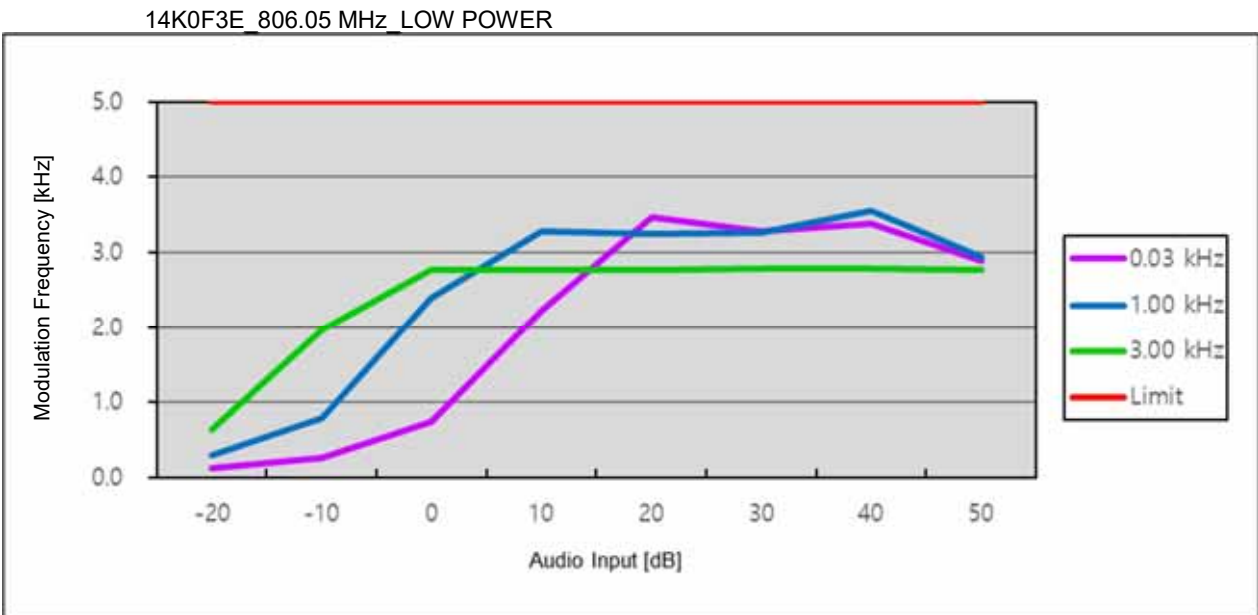
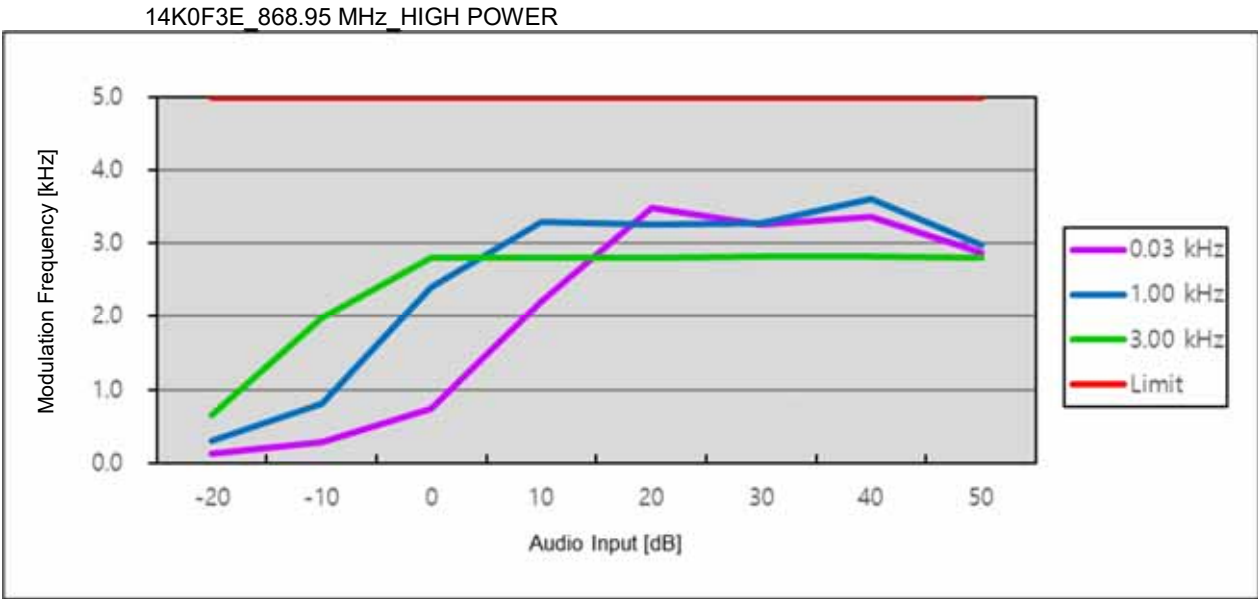

14K0F3E_851.05 MHz_LOW POWER

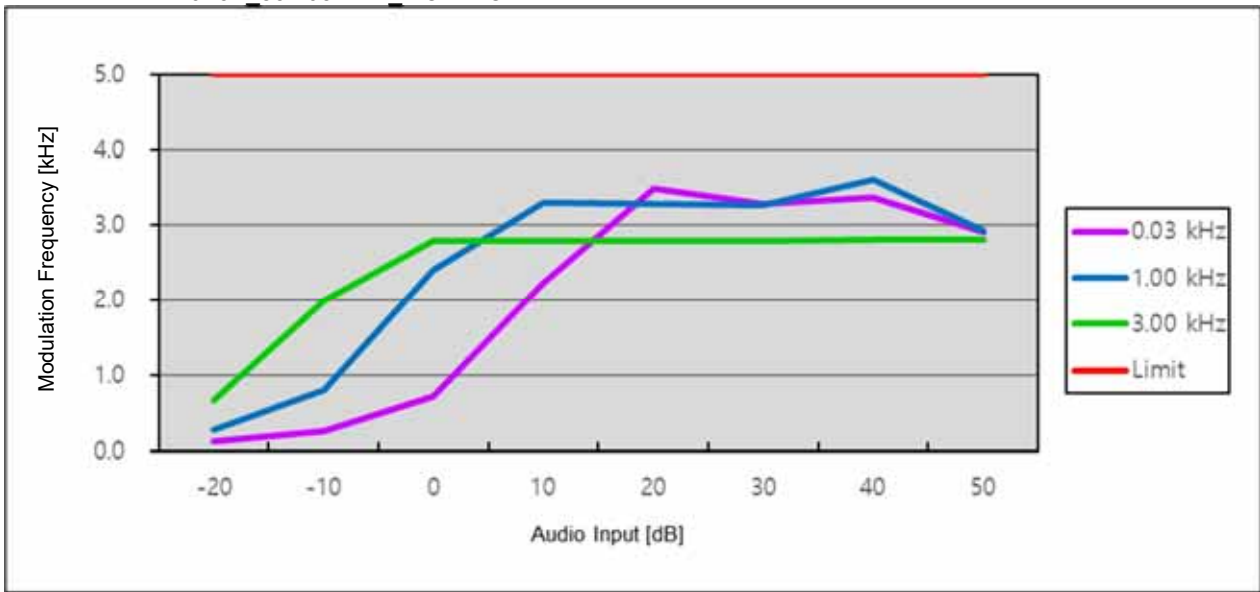

14K0F3E_868.95 MHz_LOW POWER

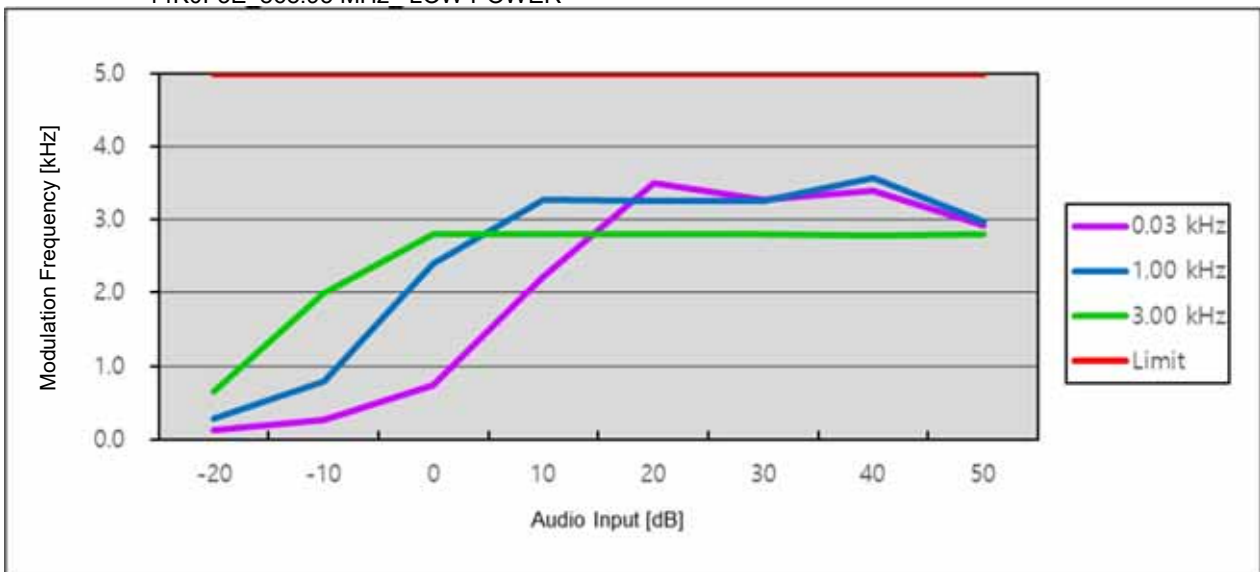

Negative Peaks

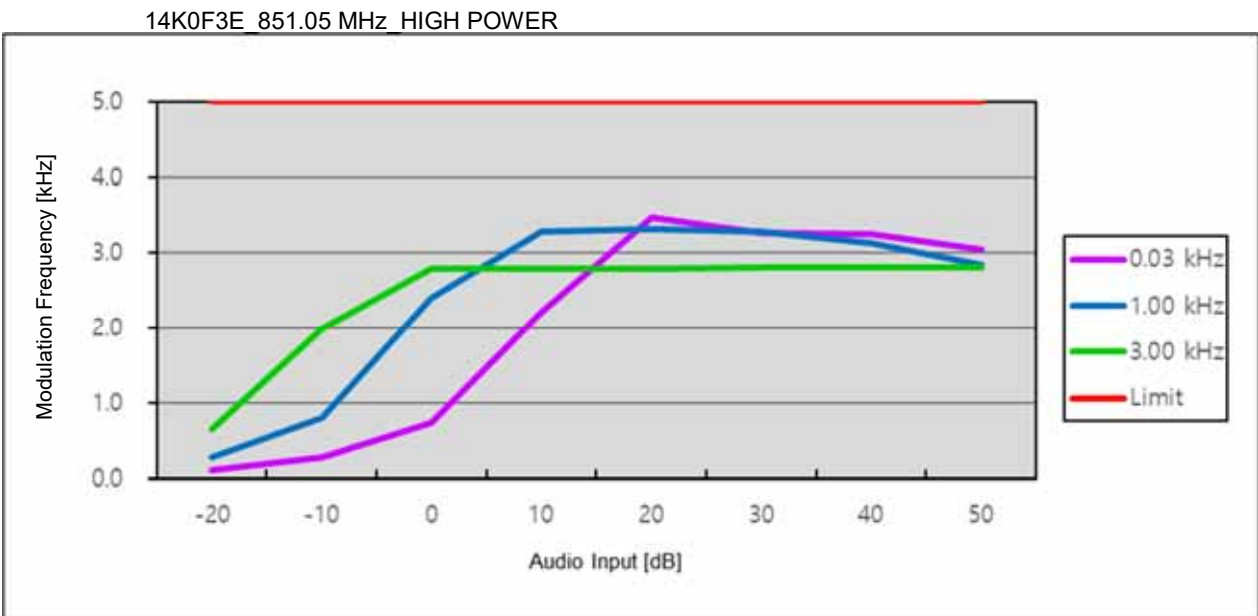
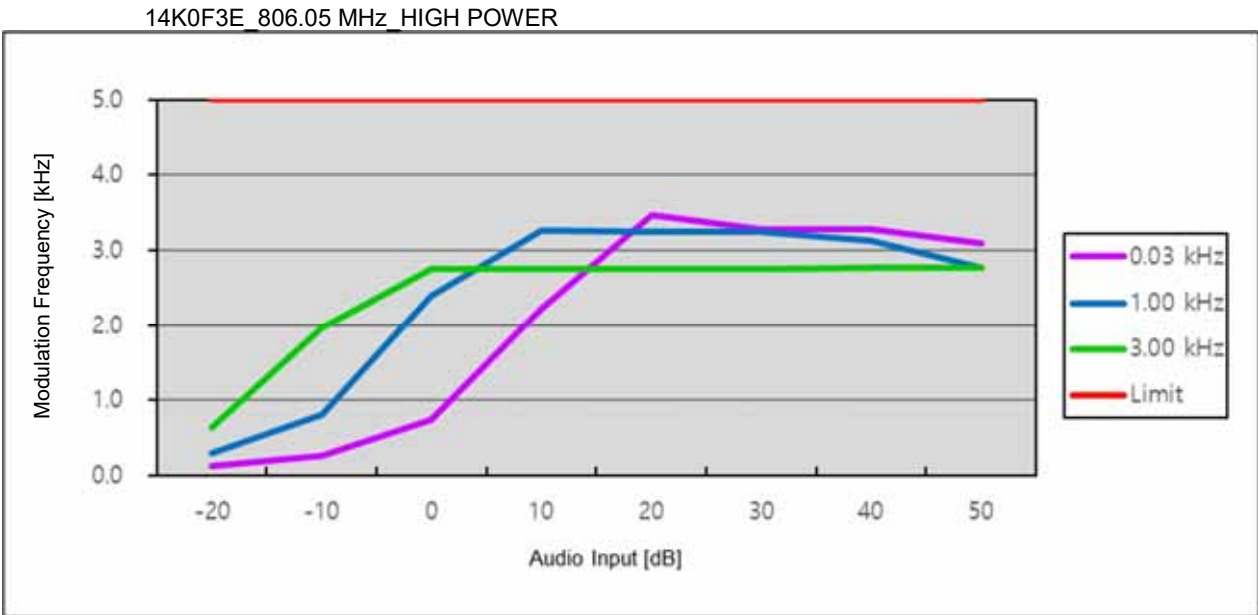

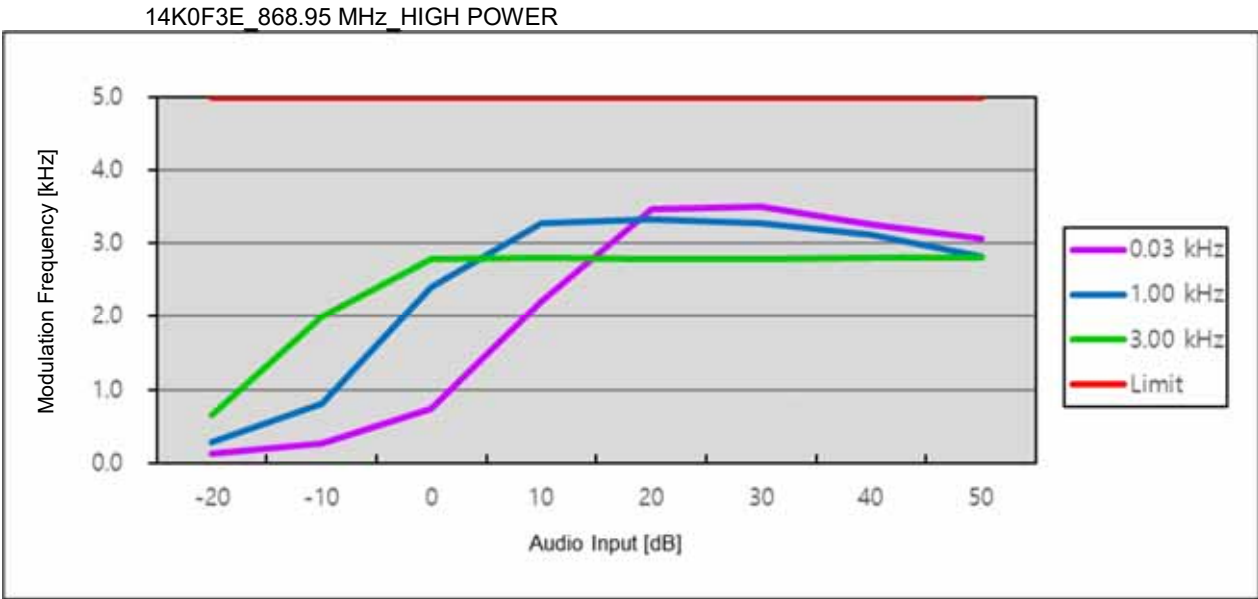

14K0F3E_851.05 MHz_LOW POWER

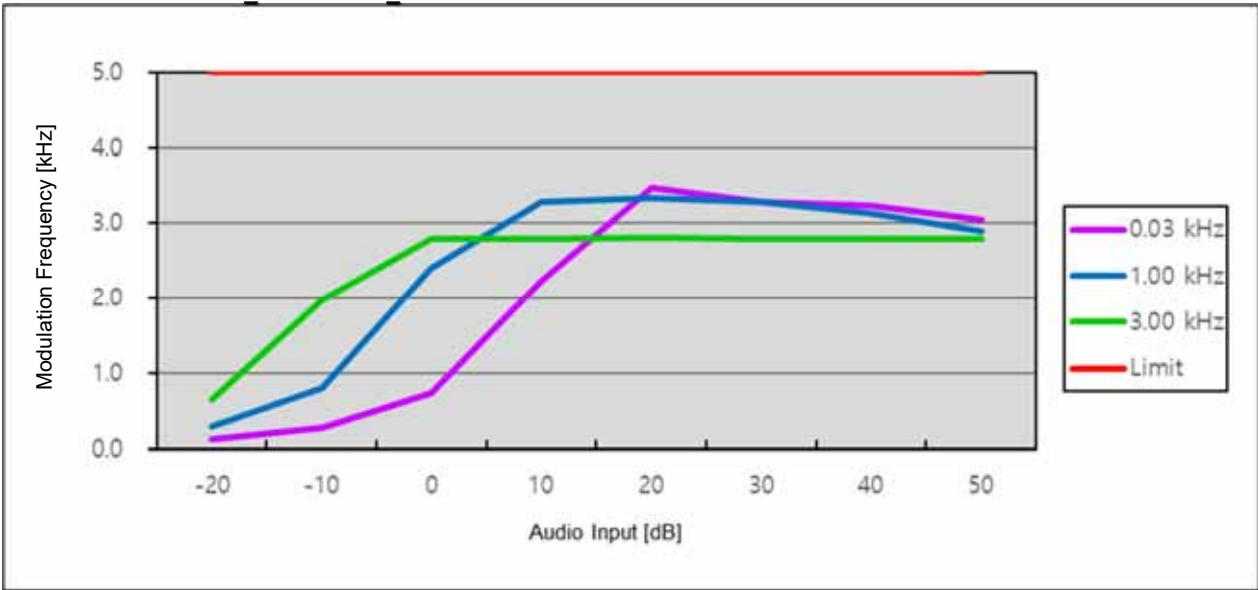

14K0F3E_868.95 MHz_LOW POWER

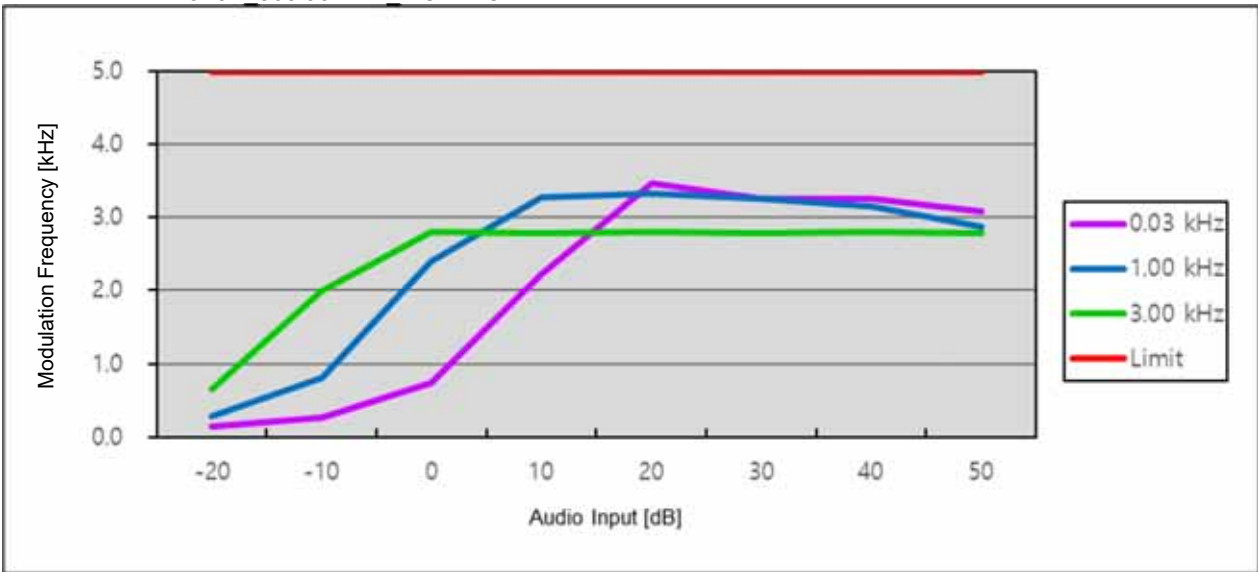

TEST RESULTS (16K0F3E)

Positive Peaks

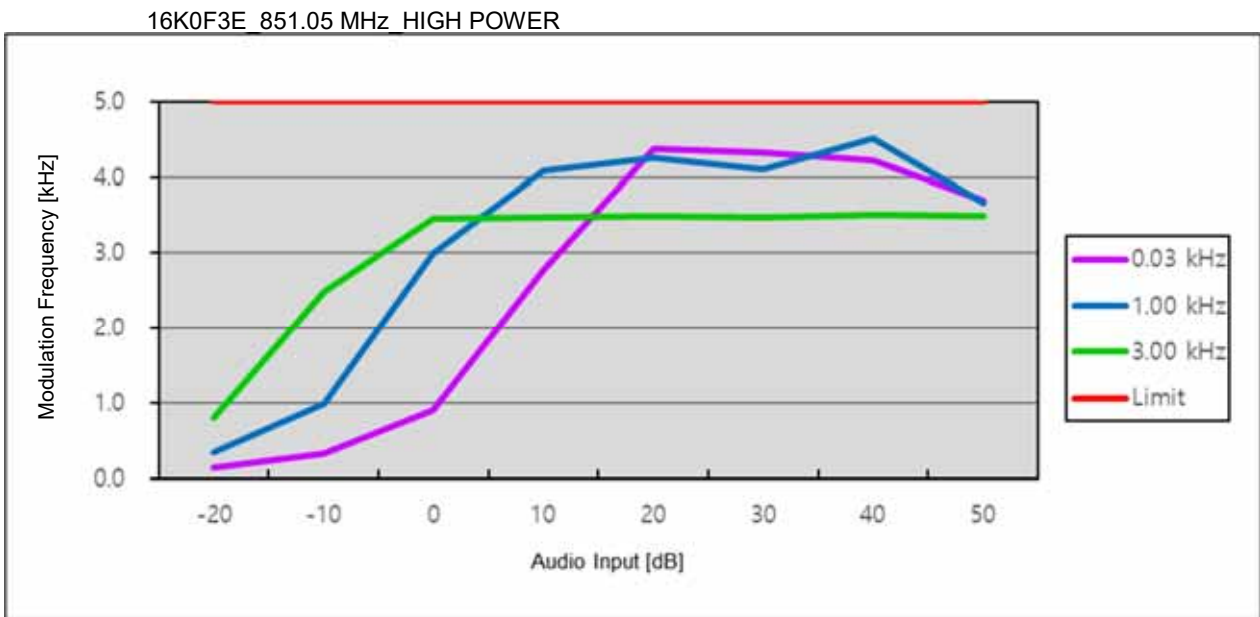
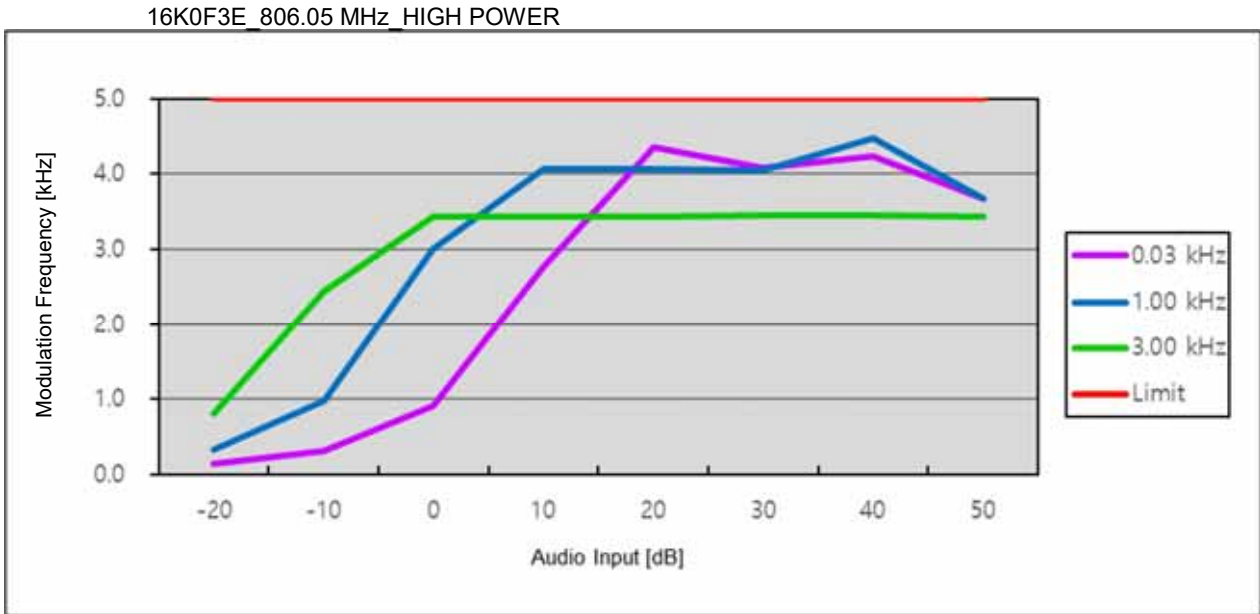

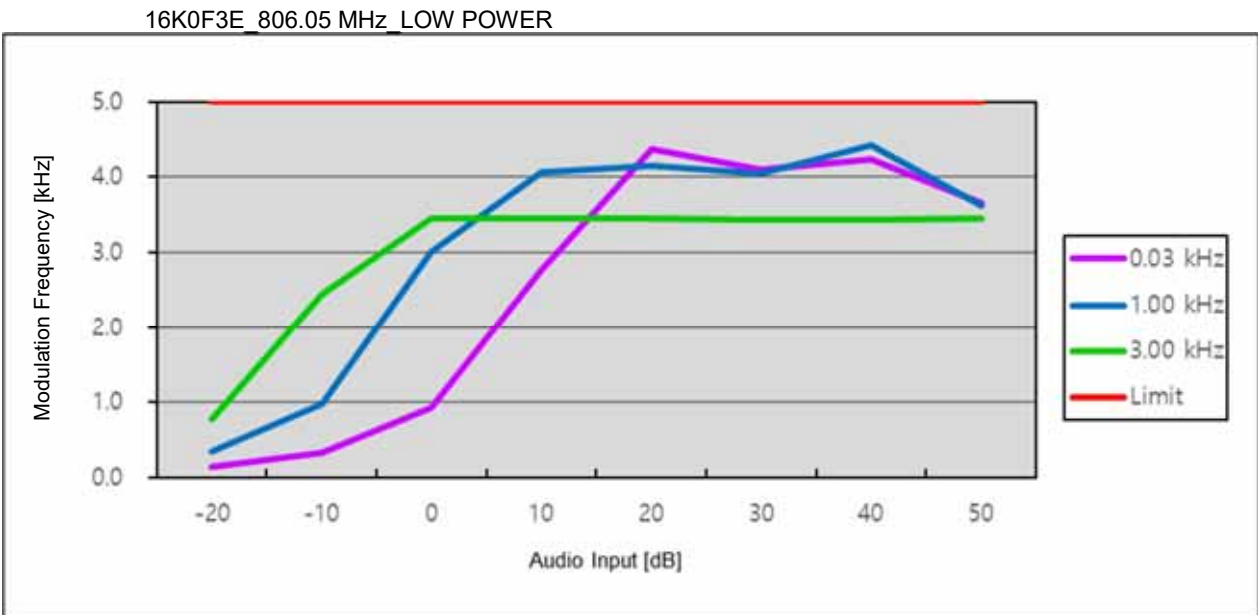
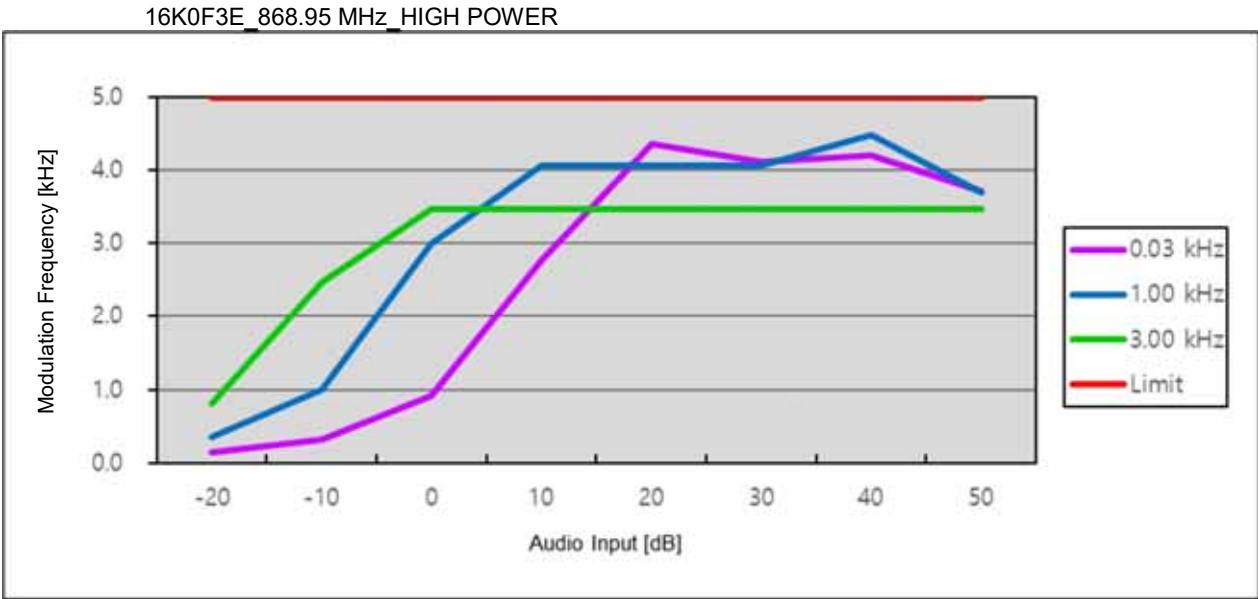

16K0F3E_851.05 MHz_LOW POWER

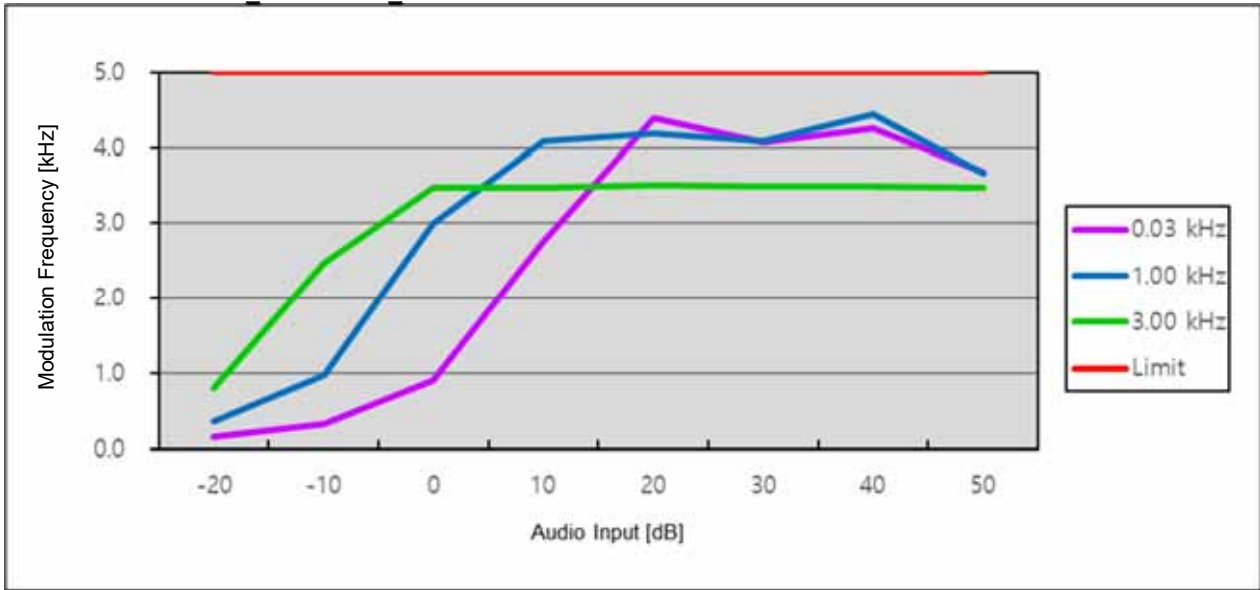

16K0F3E_868.95 MHz_LOW POWER

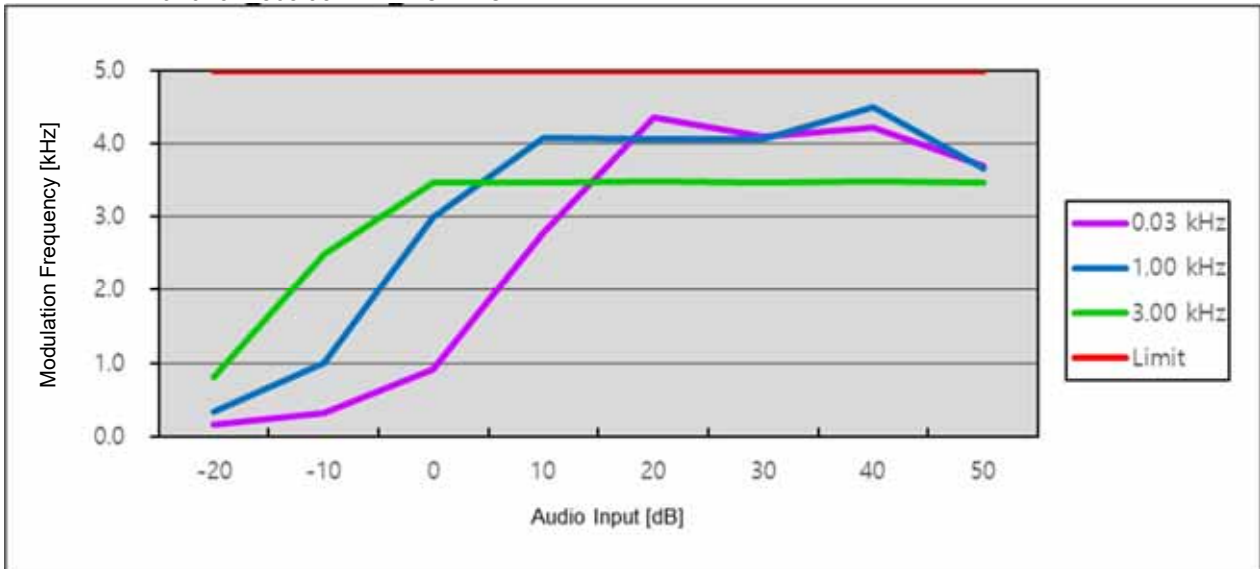

Negative Peaks

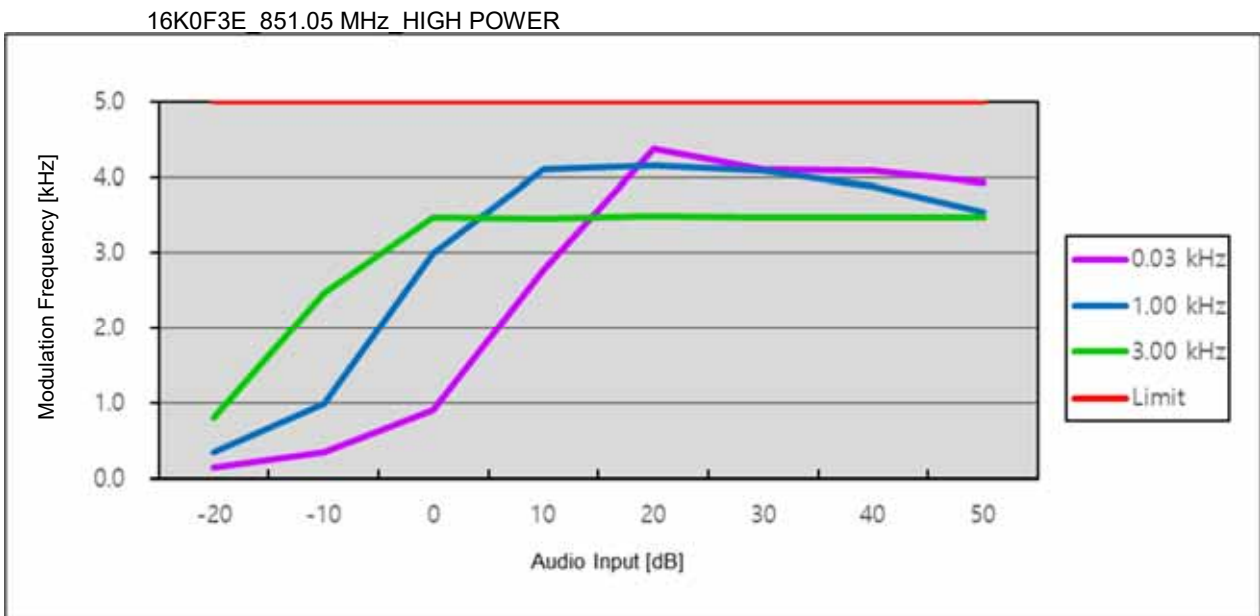
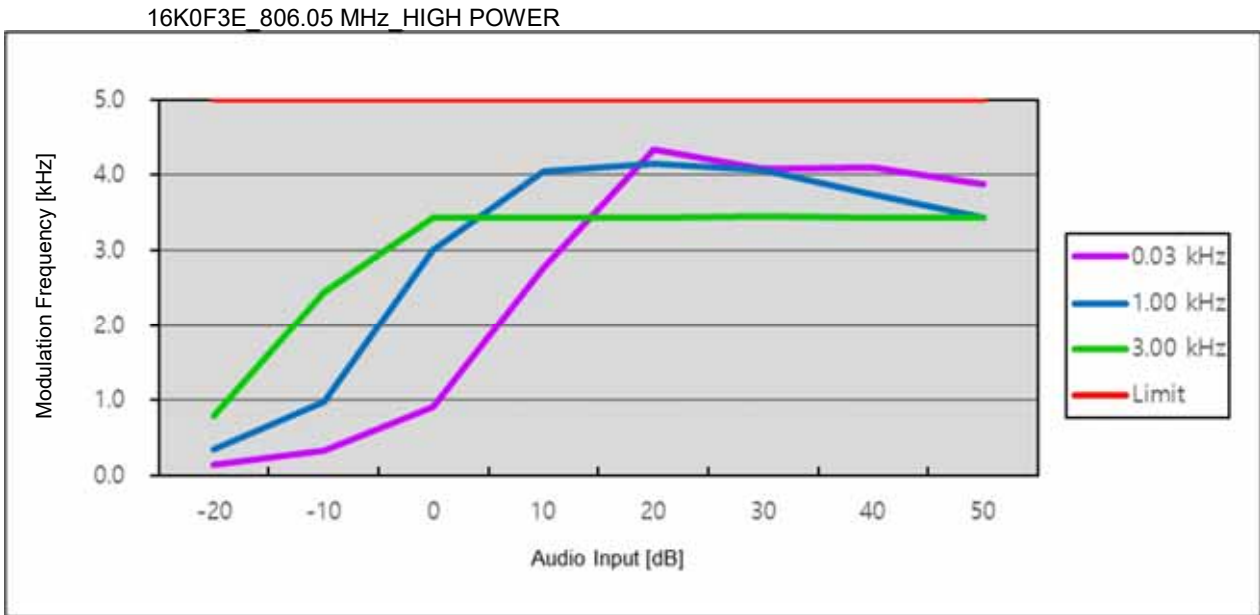

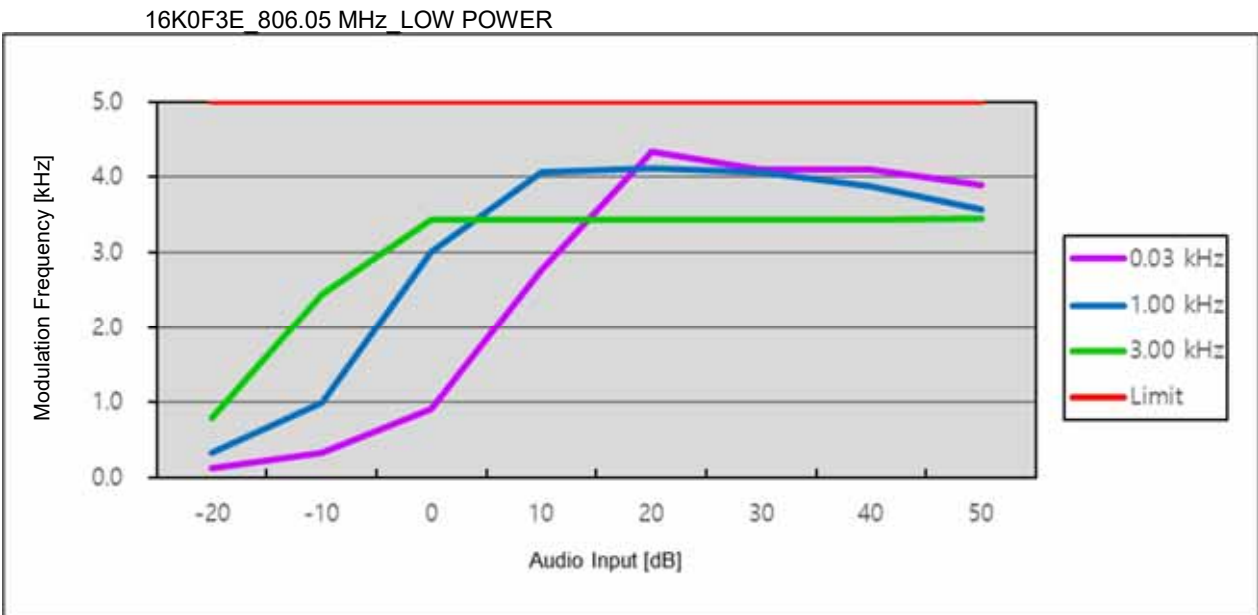
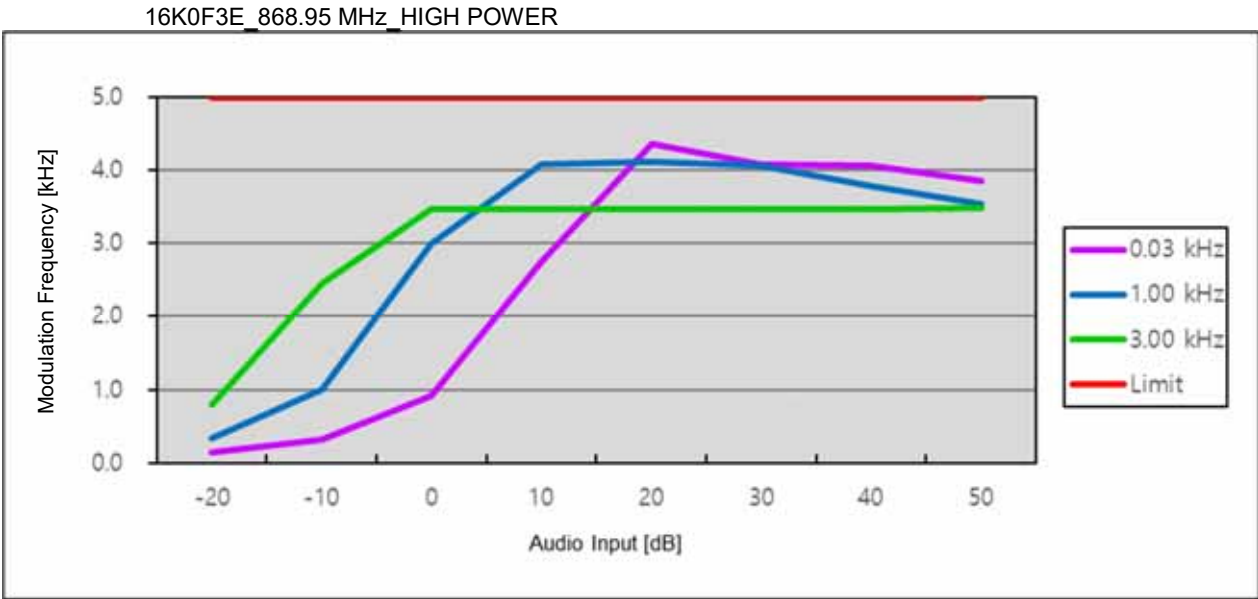

16K0F3E_851.05 MHz_LOW POWER

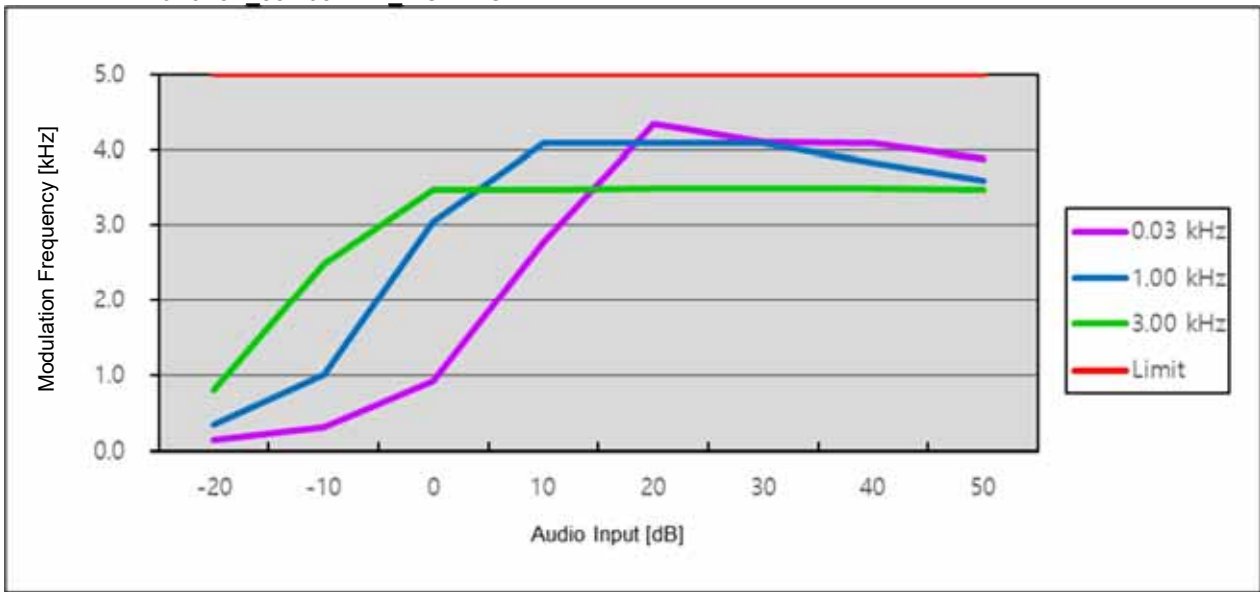

16K0F3E_868.95 MHz_LOW POWER

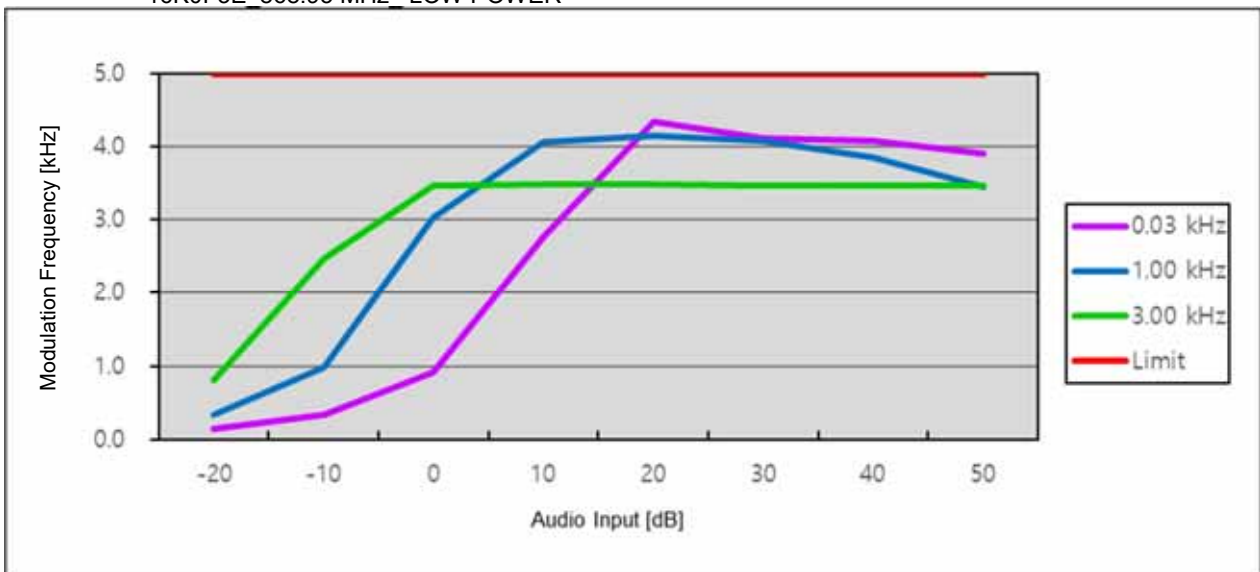

10.5 Audio Frequency Response / Audio Low Pass Filter Response

Definition

The audio frequency response is the degree of closeness to which the frequency deviation of the transmitter follows a prescribed characteristic.

TEST CONFIGURATION

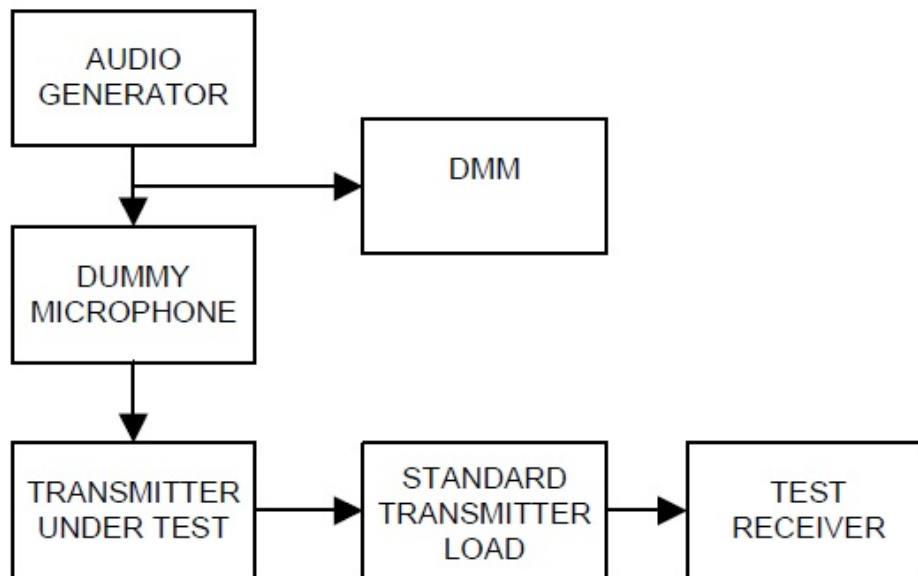

TEST PROCEDURE

According to 2.2.6 in TIA-603-E Standard.

- a) Connect the equipment as illustrated.
- b) Set the test receiver to measure peak positive deviation. Set the audio bandwidth for ≤ 50 Hz to $\geq 15,000$ Hz. Turn the de-emphasis function off.
- c) Set the DMM to measure rms voltage.
- d) Adjust the transmitter per the manufacturer's procedure for full rated system deviation.
- e) Apply a 1000 Hz tone and adjust the audio frequency generator to produce 20% of the rated system deviation.
- f) Set the test receiver to measure rms deviation and record the deviation reading.
- g) Record the DMM reading as V_{REF} .
- h) Set the audio frequency generator to the desired test frequency between 300 Hz and 3000 Hz.
- i) Vary the audio frequency generator output level until the deviation reading that was recorded in step f) is obtained.
- j) Record the DMM reading as V_{FREQ} .
- k) Calculate the audio frequency response at the present frequency as:

audio frequency response = $20 * \log_{10}(V_{\text{FREQ}}/V_{\text{REF}})$

- l) Repeat steps h) through k) for all the desired test frequencies.

Note

Audio Filter of the below result is substituted with the same structure as Audio Frequency Response.

On the transmission condition below 3kHz, Transceiver shows pre-emphasis condition of transmission function.

On the transmission condition above 3kHz, Transceiver shows Audio Low Pass Filter.

TEST RESULTS (11K0F3E)

Frequency (Hz)	Attenuation Rel. to 1kHz (dB)	Upper limit (dB)	Lower limit (dB)
100	-25.14	-18.93	-42.86
125	-24.22	-17.00	-39.00
300	-10.67	-9.42	-23.84
500	-5.74	-5.00	-9.00
750	-2.31	-1.49	-5.49
1000	0.00	1.00	-3.00
1250	1.93	2.93	-1.07
1500	3.46	4.51	0.51
2000	5.82	7.00	3.00
2500	7.74	8.93	4.93
3000	8.23	10.51	4.93
4000	-13.71	-	-
5000	-13.83	-	-
6000	-13.63	-	-
7000	-13.76	-	-
8000	-13.66	-	-
9000	-13.68	-	-
10000	-13.74	-	-
20000	-13.73	-	-
30000	-13.65	-	-
40000	-13.77	-	-

11K0F3E_806.05 MHz_HIGH POWER

Audio Frequency Response

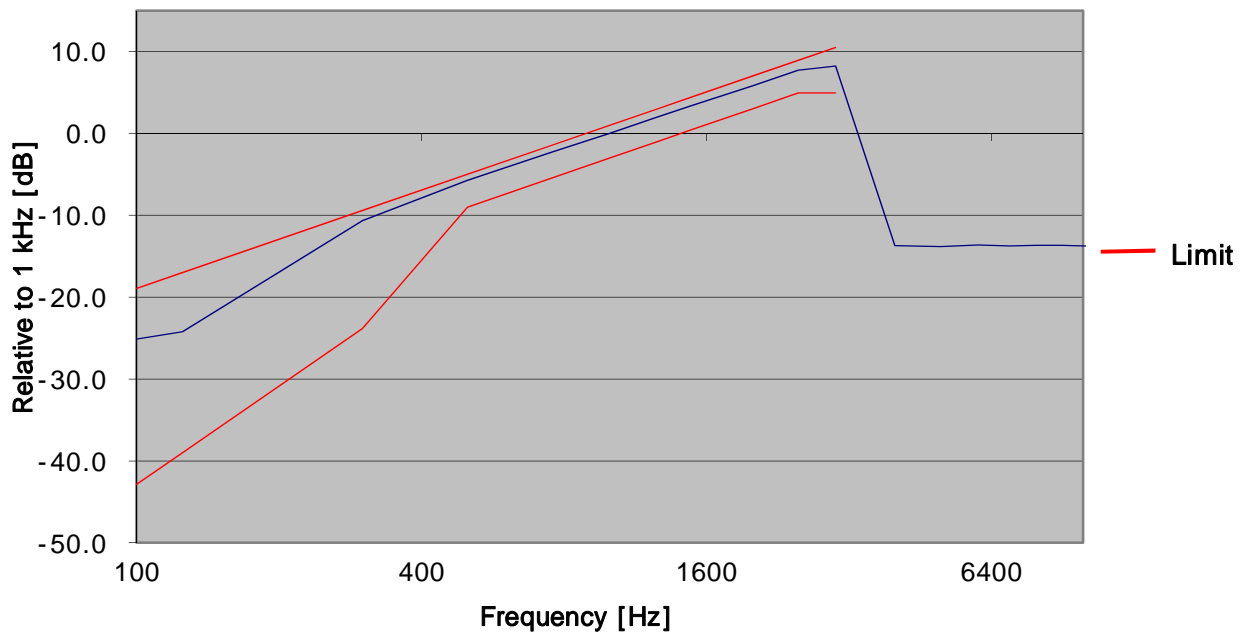

Frequency (Hz)	Attenuation Rel. to 1kHz (dB)	Upper limit (dB)	Lower limit (dB)
100	-24.41	-18.93	-42.86
125	-24.54	-17.00	-39.00
300	-10.63	-9.42	-23.84
500	-5.75	-5.00	-9.00
750	-2.32	-1.49	-5.49
1000	0.00	1.00	-3.00
1250	1.94	2.93	-1.07
1500	3.47	4.51	0.51
2000	5.84	7.00	3.00
2500	7.75	8.93	4.93
3000	8.25	10.51	4.93
4000	-13.26	-	-
5000	-13.50	-	-
6000	-13.39	-	-
7000	-13.42	-	-
8000	-13.46	-	-
9000	-13.39	-	-
10000	-13.44	-	-
20000	-13.46	-	-
30000	-13.42	-	-
40000	-13.46	-	-

11K0F3E_851.05 MHz_HIGH POWER

Audio Frequency Response

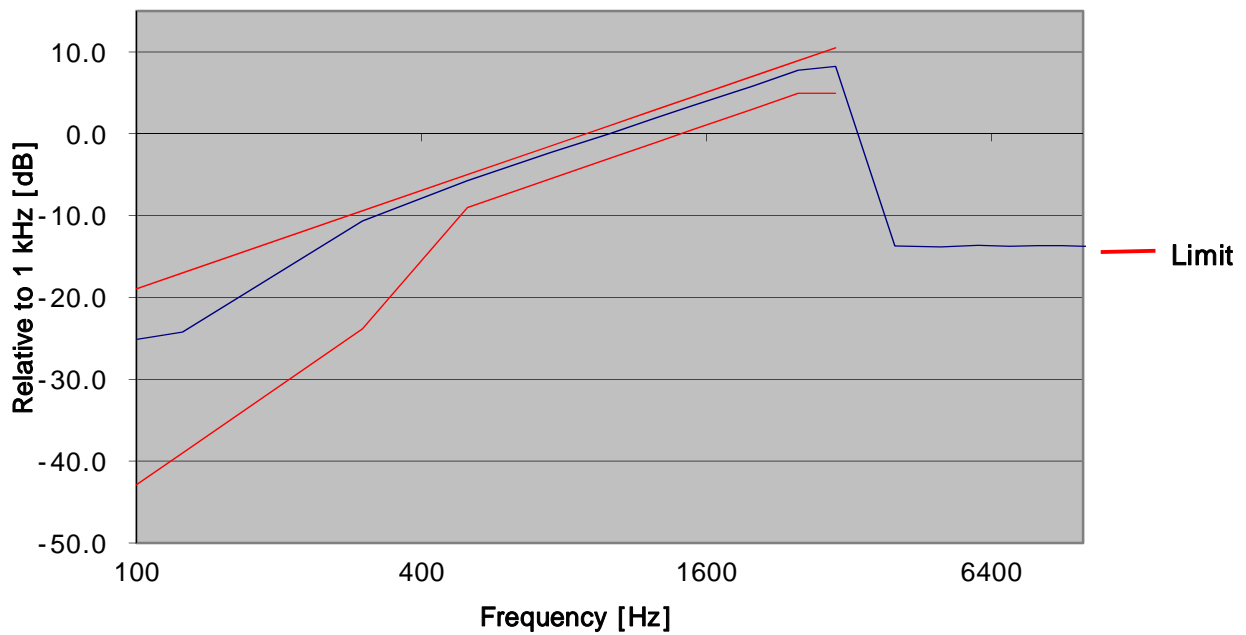

Frequency (Hz)	Attenuation Rel. to 1kHz (dB)	Upper limit (dB)	Lower limit (dB)
100	-24.29	-18.93	-42.86
125	-24.34	-17.00	-39.00
300	-10.66	-9.42	-23.84
500	-5.74	-5.00	-9.00
750	-2.34	-1.49	-5.49
1000	0.00	1.00	-3.00
1250	1.93	2.93	-1.07
1500	3.46	4.51	0.51
2000	5.84	7.00	3.00
2500	7.73	8.93	4.93
3000	8.26	10.51	4.93
4000	-13.25	-	-
5000	-13.24	-	-
6000	-13.29	-	-
7000	-13.27	-	-
8000	-13.29	-	-
9000	-13.20	-	-
10000	-13.33	-	-
20000	-13.25	-	-
30000	-13.25	-	-
40000	-13.32	-	-

11K0F3E_868.95 MHz_HIGH POWER

Audio Frequency Response

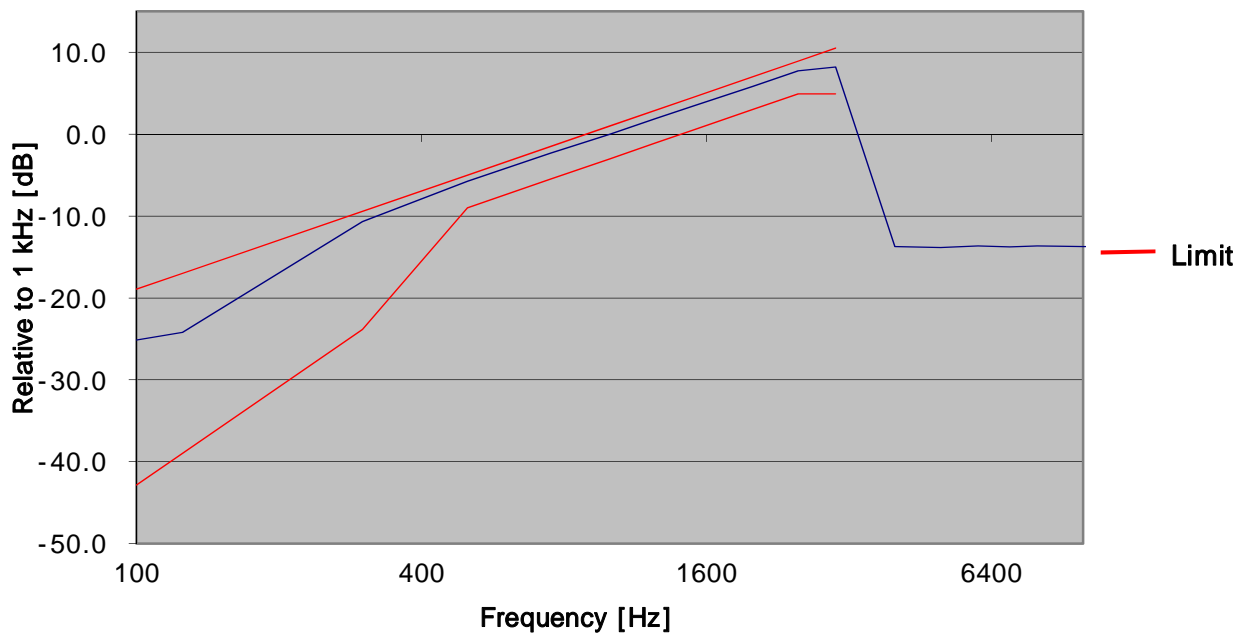

Frequency (Hz)	Attenuation Rel. to 1kHz (dB)	Upper limit (dB)	Lower limit (dB)
100	-24.08	-18.93	-42.86
125	-24.29	-17.00	-39.00
300	-10.63	-9.42	-23.84
500	-5.75	-5.00	-9.00
750	-2.33	-1.49	-5.49
1000	0.00	1.00	-3.00
1250	1.93	2.93	-1.07
1500	3.44	4.51	0.51
2000	5.82	7.00	3.00
2500	7.71	8.93	4.93
3000	8.21	10.51	4.93
4000	-13.75	-	-
5000	-13.77	-	-
6000	-13.74	-	-
7000	-13.90	-	-
8000	-13.90	-	-
9000	-13.80	-	-
10000	-13.90	-	-
20000	-13.86	-	-
30000	-13.80	-	-
40000	-13.91	-	-

11K0F3E_900.95 MHz_HIGH POWER

Audio Frequency Response

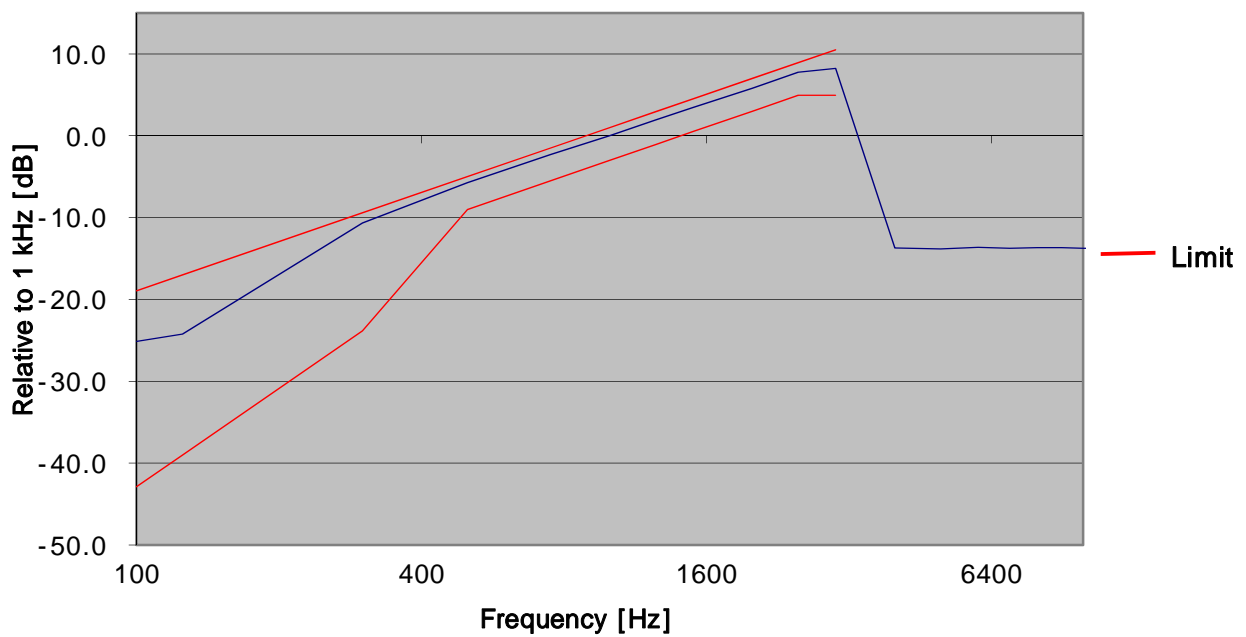

Frequency (Hz)	Attenuation Rel. to 1kHz (dB)	Upper limit (dB)	Lower limit (dB)
100	-24.05	-18.93	-42.86
125	-23.73	-17.00	-39.00
300	-10.58	-9.42	-23.84
500	-5.73	-5.00	-9.00
750	-2.34	-1.49	-5.49
1000	0.00	1.00	-3.00
1250	1.90	2.93	-1.07
1500	3.45	4.51	0.51
2000	5.82	7.00	3.00
2500	7.72	8.93	4.93
3000	8.23	10.51	4.93
4000	-13.29	-	-
5000	-13.24	-	-
6000	-13.33	-	-
7000	-13.27	-	-
8000	-13.21	-	-
9000	-13.28	-	-
10000	-13.30	-	-
20000	-13.38	-	-
30000	-13.37	-	-
40000	-13.33	-	-

11K0F3E_939.95 MHz_HIGH POWER

Audio Frequency Response

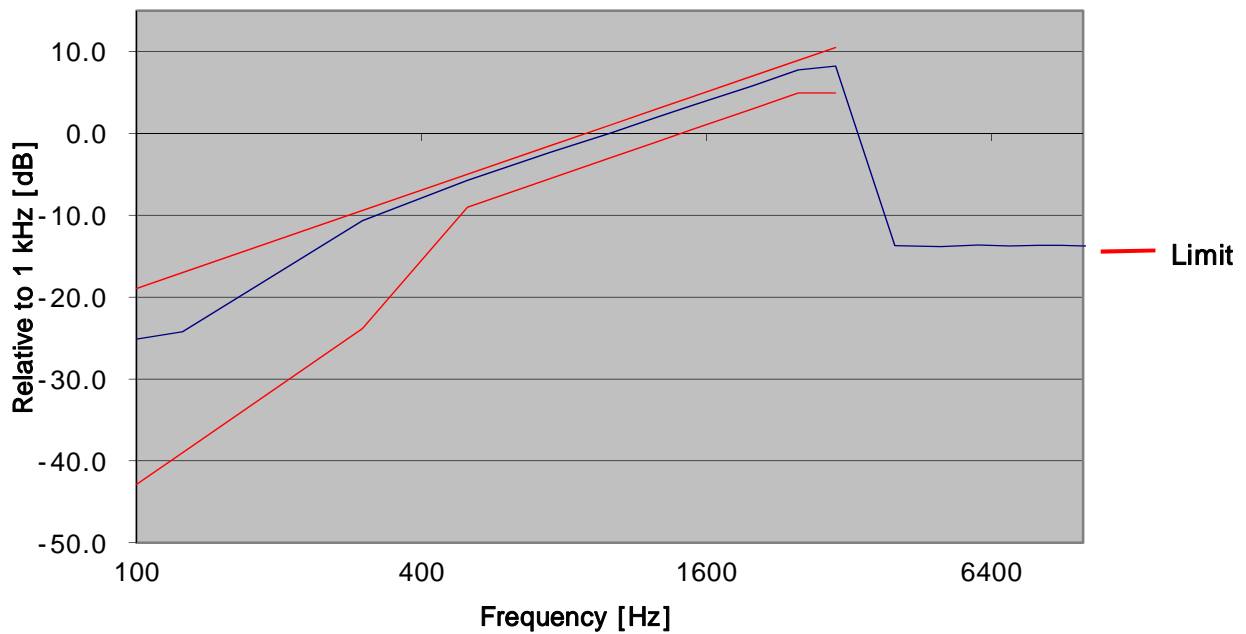

Frequency (Hz)	Attenuation Rel. to 1kHz (dB)	Upper limit (dB)	Lower limit (dB)
100	-24.62	-18.93	-42.86
125	-24.36	-17.00	-39.00
300	-10.55	-9.42	-23.84
500	-5.75	-5.00	-9.00
750	-2.32	-1.49	-5.49
1000	0.00	1.00	-3.00
1250	1.92	2.93	-1.07
1500	3.46	4.51	0.51
2000	5.84	7.00	3.00
2500	7.73	8.93	4.93
3000	8.22	10.51	4.93
4000	-13.78	-	-
5000	-13.95	-	-
6000	-13.92	-	-
7000	-13.85	-	-
8000	-13.82	-	-
9000	-13.85	-	-
10000	-13.92	-	-
20000	-13.94	-	-
30000	-13.86	-	-
40000	-13.98	-	-

11K0F3E_901.55 MHz_ HIGH POWER

Audio Frequency Response

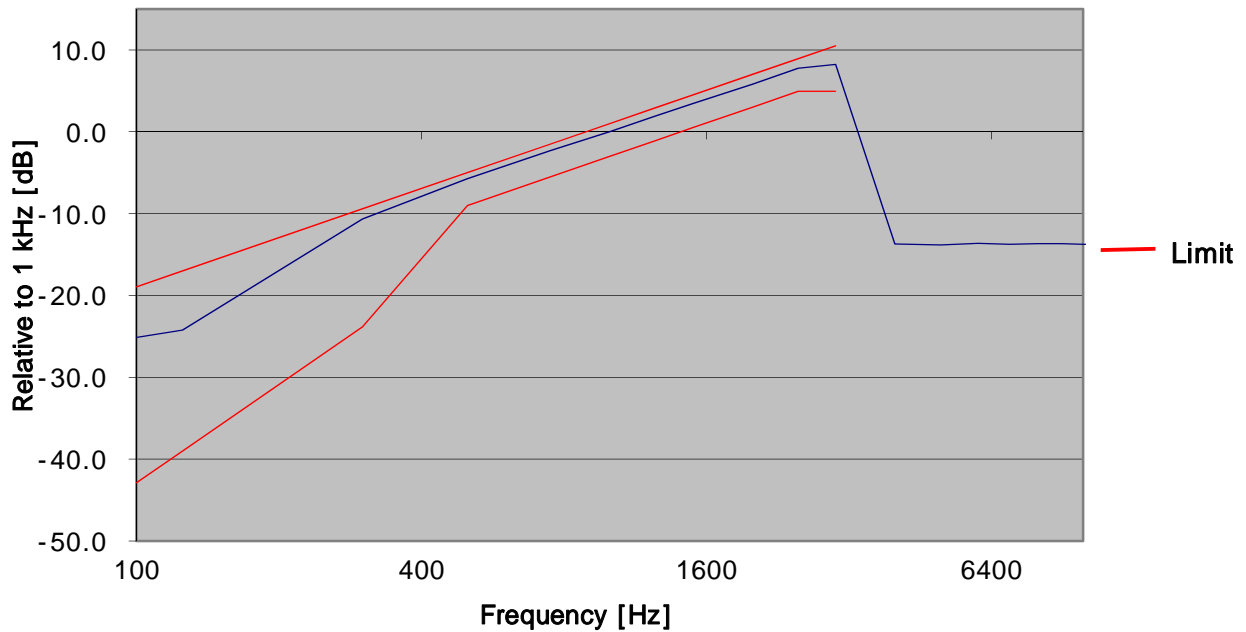

Frequency (Hz)	Attenuation Rel. to 1kHz (dB)	Upper limit (dB)	Lower limit (dB)
100	-23.98	-18.93	-42.86
125	-23.98	-17.00	-39.00
300	-10.63	-9.42	-23.84
500	-5.74	-5.00	-9.00
750	-2.34	-1.49	-5.49
1000	0.00	1.00	-3.00
1250	1.91	2.93	-1.07
1500	3.47	4.51	0.51
2000	5.84	7.00	3.00
2500	7.73	8.93	4.93
3000	8.23	10.51	4.93
4000	-13.33	-	-
5000	-13.40	-	-
6000	-13.40	-	-
7000	-13.39	-	-
8000	-13.31	-	-
9000	-13.37	-	-
10000	-13.38	-	-
20000	-13.34	-	-
30000	-13.33	-	-
40000	-13.41	-	-

11K0F3E_940.55 MHz_ HIGH POWER

Audio Frequency Response

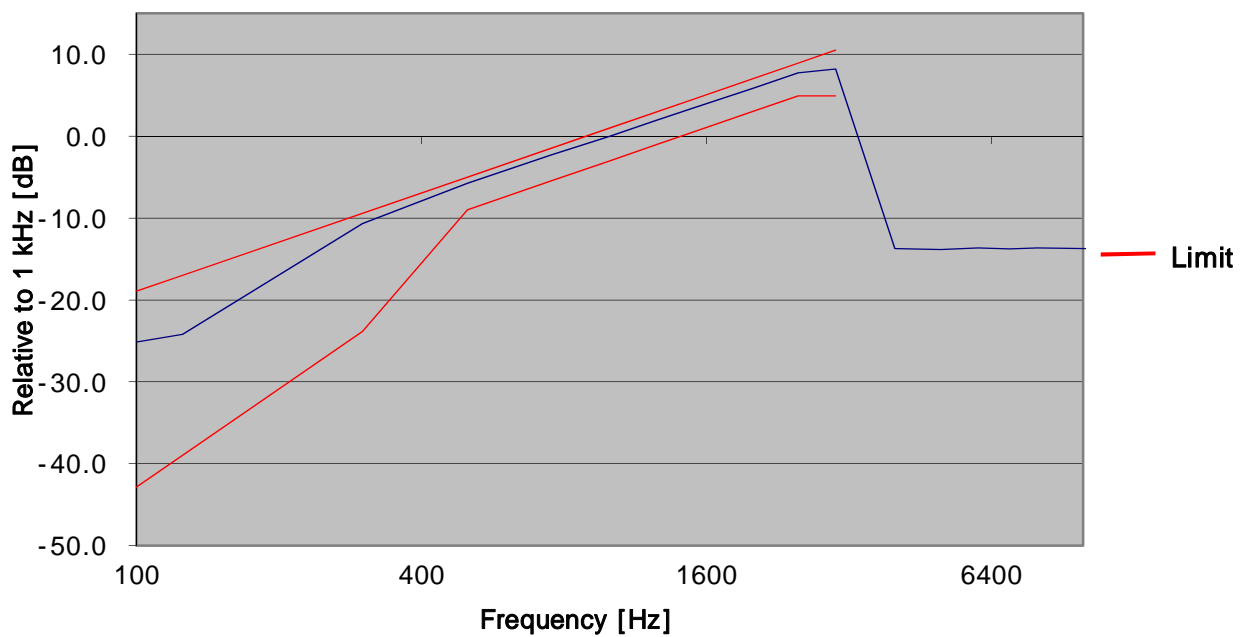

Frequency (Hz)	Attenuation Rel. to 1kHz (dB)	Upper limit (dB)	Lower limit (dB)
100	-25.11	-18.93	-42.86
125	-24.88	-17.00	-39.00
300	-10.69	-9.42	-23.84
500	-5.74	-5.00	-9.00
750	-2.34	-1.49	-5.49
1000	0.00	1.00	-3.00
1250	1.90	2.93	-1.07
1500	3.45	4.51	0.51
2000	5.79	7.00	3.00
2500	7.69	8.93	4.93
3000	8.20	10.51	4.93
4000	-13.90	-	-
5000	-13.80	-	-
6000	-13.78	-	-
7000	-13.74	-	-
8000	-13.67	-	-
9000	-13.71	-	-
10000	-13.79	-	-
20000	-13.75	-	-
30000	-13.69	-	-
40000	-13.83	-	-

11K0F3E_806.05 MHz_ LOW POWER

Audio Frequency Response

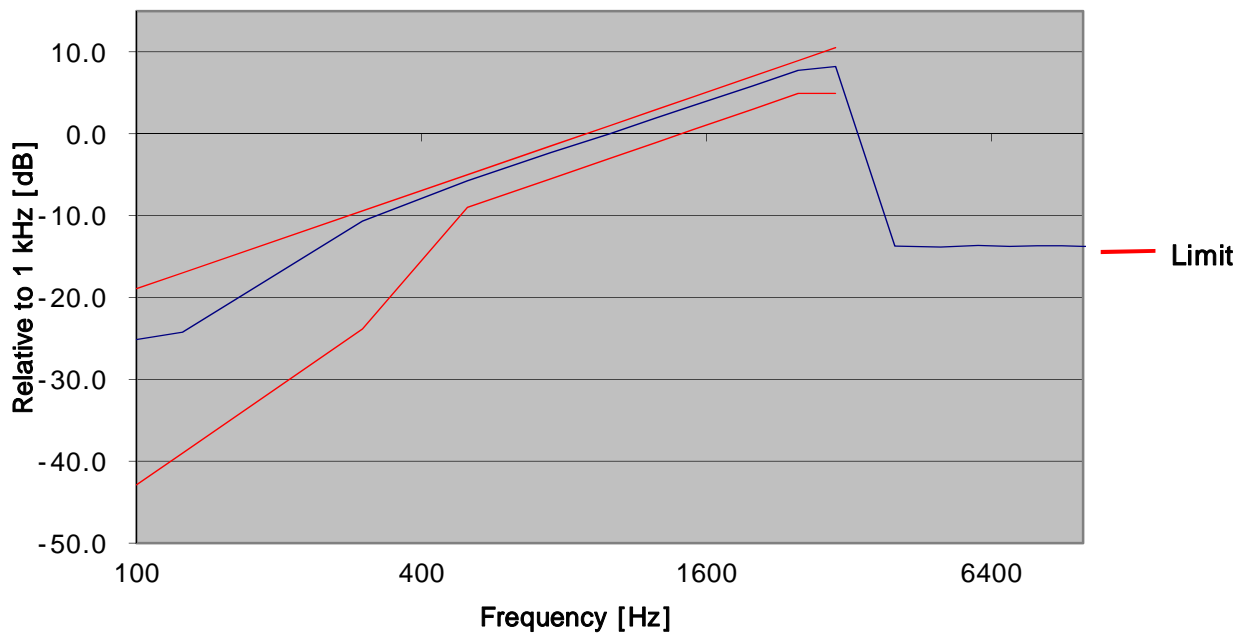

Frequency (Hz)	Attenuation Rel. to 1kHz (dB)	Upper limit (dB)	Lower limit (dB)
100	-24.38	-18.93	-42.86
125	-25.19	-17.00	-39.00
300	-10.61	-9.42	-23.84
500	-5.75	-5.00	-9.00
750	-2.35	-1.49	-5.49
1000	0.00	1.00	-3.00
1250	1.91	2.93	-1.07
1500	3.46	4.51	0.51
2000	5.82	7.00	3.00
2500	7.73	8.93	4.93
3000	8.24	10.51	4.93
4000	-13.45	-	-
5000	-13.47	-	-
6000	-13.54	-	-
7000	-13.40	-	-
8000	-13.52	-	-
9000	-13.42	-	-
10000	-13.47	-	-
20000	-13.49	-	-
30000	-13.50	-	-
40000	-13.43	-	-

11K0F3E_851.05 MHz_ LOW POWER

Audio Frequency Response

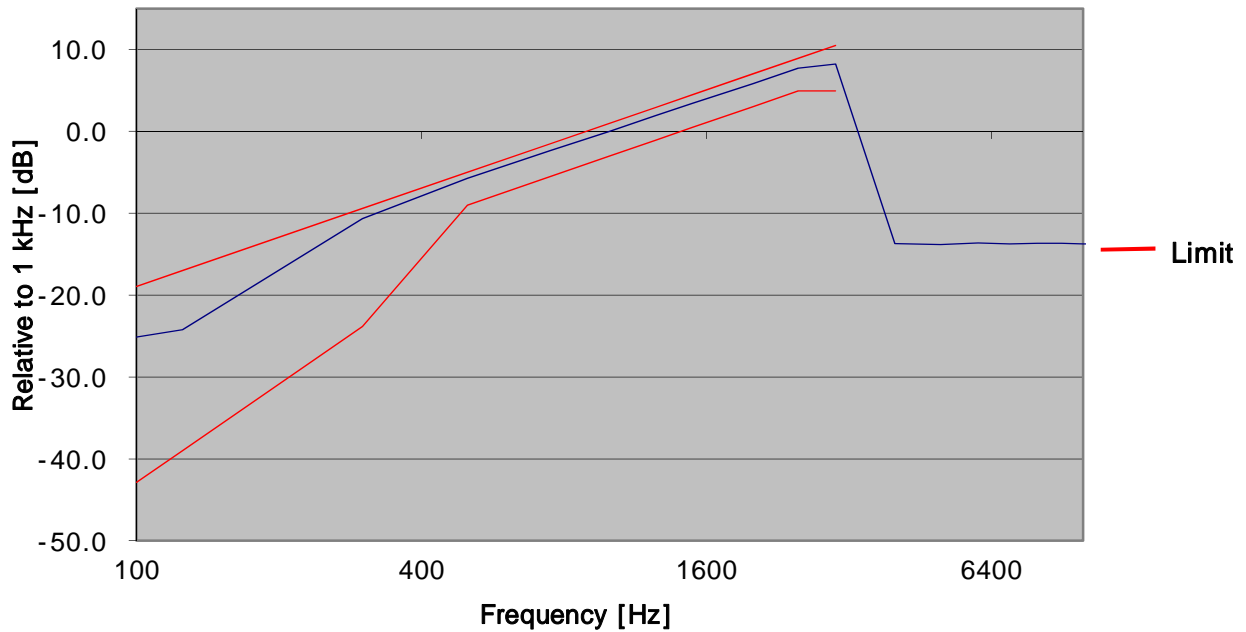

Frequency (Hz)	Attenuation Rel. to 1kHz (dB)	Upper limit (dB)	Lower limit (dB)
100	-24.04	-18.93	-42.86
125	-24.38	-17.00	-39.00
300	-10.58	-9.42	-23.84
500	-5.72	-5.00	-9.00
750	-2.34	-1.49	-5.49
1000	0.00	1.00	-3.00
1250	1.93	2.93	-1.07
1500	3.44	4.51	0.51
2000	5.84	7.00	3.00
2500	7.73	8.93	4.93
3000	8.25	10.51	4.93
4000	-13.28	-	-
5000	-13.27	-	-
6000	-13.31	-	-
7000	-13.37	-	-
8000	-13.30	-	-
9000	-13.27	-	-
10000	-13.26	-	-
20000	-13.31	-	-
30000	-13.33	-	-
40000	-13.32	-	-

11K0F3E_868.95 MHz_ LOW POWER

Audio Frequency Response

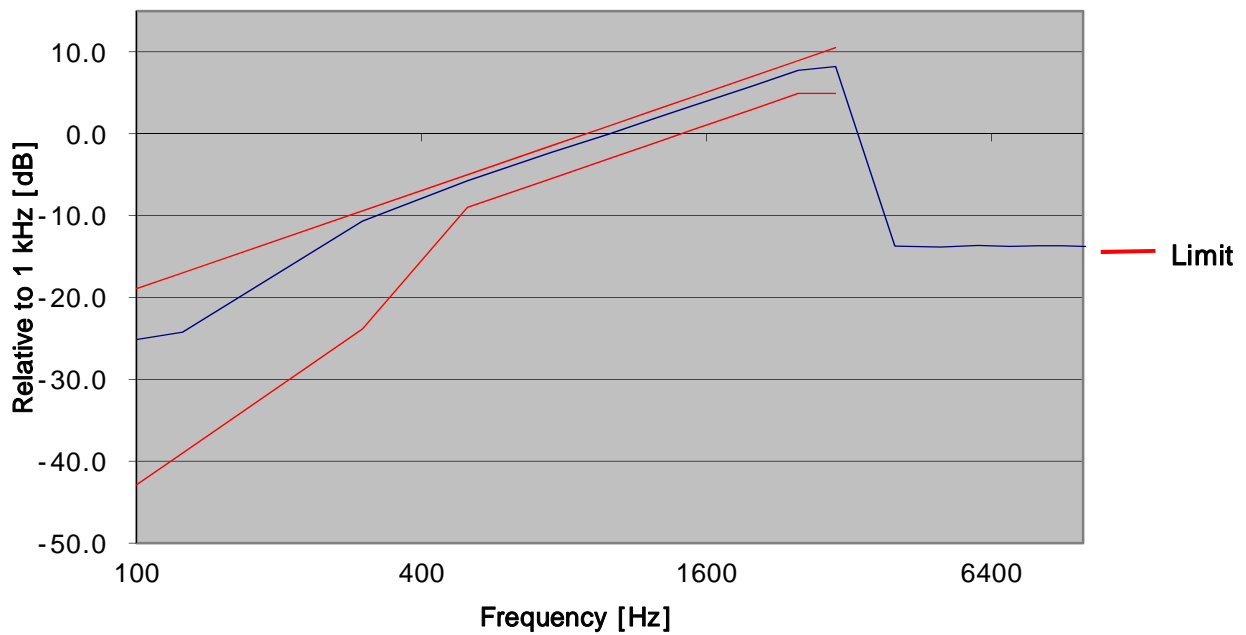

Frequency (Hz)	Attenuation Rel. to 1kHz (dB)	Upper limit (dB)	Lower limit (dB)
100	-34.05	-18.93	-42.86
125	-34.28	-17.00	-39.00
300	-10.83	-9.42	-23.84
500	-5.82	-5.00	-9.00
750	-2.39	-1.49	-5.49
1000	0.00	1.00	-3.00
1250	1.91	2.93	-1.07
1500	3.45	4.51	0.51
2000	5.81	7.00	3.00
2500	7.72	8.93	4.93
3000	8.19	10.51	4.93
4000	-21.56	-	-
5000	-21.48	-	-
6000	-21.46	-	-
7000	-21.51	-	-
8000	-21.51	-	-
9000	-21.57	-	-
10000	-21.49	-	-
20000	-21.59	-	-
30000	-21.51	-	-
40000	-21.45	-	-

11K0F3E_900.95 MHz_LOW POWER

Audio Frequency Response

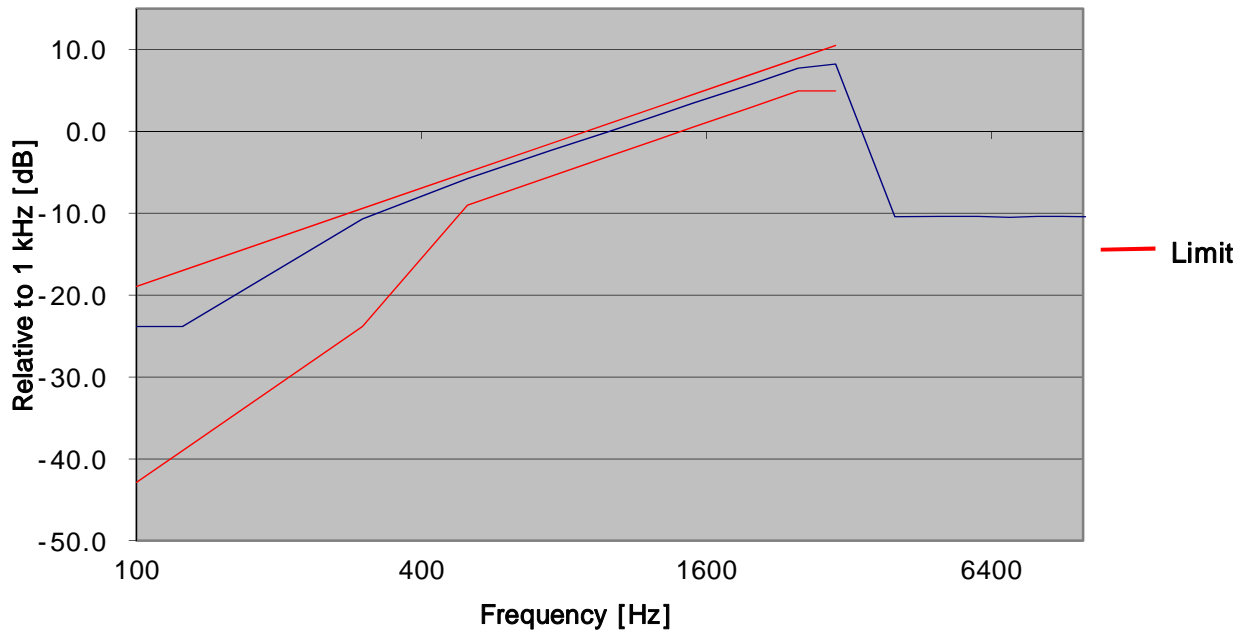

Frequency (Hz)	Attenuation Rel. to 1kHz (dB)	Upper limit (dB)	Lower limit (dB)
100	-33.83	-18.93	-42.86
125	-34.09	-17.00	-39.00
300	-10.89	-9.42	-23.84
500	-5.80	-5.00	-9.00
750	-2.40	-1.49	-5.49
1000	0.00	1.00	-3.00
1250	1.91	2.93	-1.07
1500	3.46	4.51	0.51
2000	5.81	7.00	3.00
2500	7.72	8.93	4.93
3000	8.18	10.51	4.93
4000	-20.95	-	-
5000	-20.99	-	-
6000	-20.95	-	-
7000	-20.94	-	-
8000	-20.91	-	-
9000	-20.82	-	-
10000	-20.92	-	-
20000	-20.98	-	-
30000	-20.97	-	-
40000	-20.88	-	-

11K0F3E_939.95 MHz_ LOW POWER

Audio Frequency Response

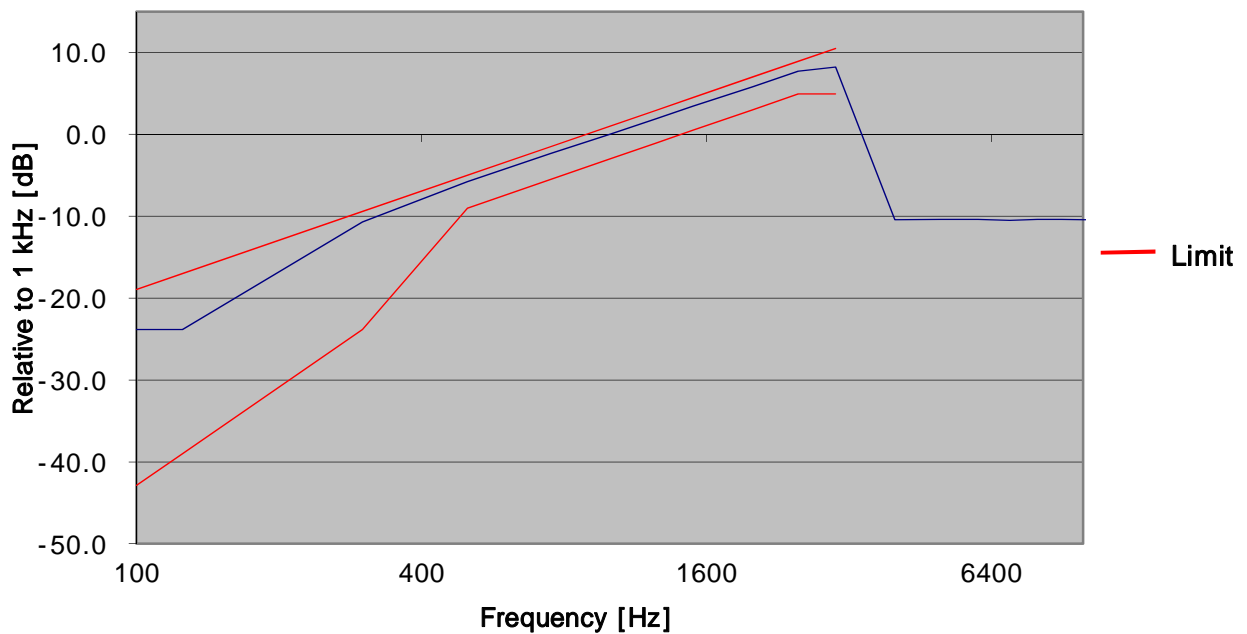

Frequency (Hz)	Attenuation Rel. to 1kHz (dB)	Upper limit (dB)	Lower limit (dB)
100	-24.49	-18.93	-42.86
125	-24.23	-17.00	-39.00
300	-10.62	-9.42	-23.84
500	-5.77	-5.00	-9.00
750	-2.32	-1.49	-5.49
1000	0.00	1.00	-3.00
1250	1.91	2.93	-1.07
1500	3.45	4.51	0.51
2000	5.82	7.00	3.00
2500	7.72	8.93	4.93
3000	8.22	10.51	4.93
4000	-13.87	-	-
5000	-13.94	-	-
6000	-13.92	-	-
7000	-13.94	-	-
8000	-13.91	-	-
9000	-13.86	-	-
10000	-13.95	-	-
20000	-13.99	-	-
30000	-13.87	-	-
40000	-13.97	-	-

11K0F3E_901.55 MHz_LOW POWER

Audio Frequency Response

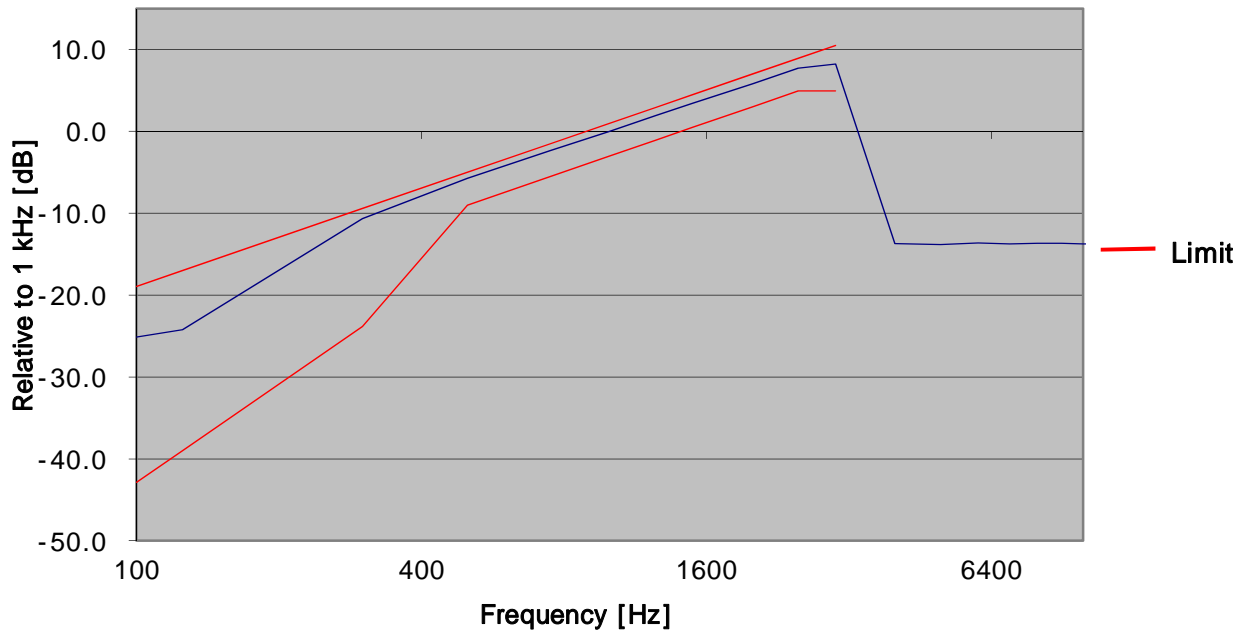

Frequency (Hz)	Attenuation Rel. to 1kHz (dB)	Upper limit (dB)	Lower limit (dB)
100	-23.85	-18.93	-42.86
125	-23.85	-17.00	-39.00
300	-10.70	-9.42	-23.84
500	-5.76	-5.00	-9.00
750	-2.34	-1.49	-5.49
1000	0.00	1.00	-3.00
1250	1.90	2.93	-1.07
1500	3.46	4.51	0.51
2000	5.82	7.00	3.00
2500	7.72	8.93	4.93
3000	8.23	10.51	4.93
4000	-13.42	-	-
5000	-13.39	-	-
6000	-13.40	-	-
7000	-13.48	-	-
8000	-13.40	-	-
9000	-13.38	-	-
10000	-13.41	-	-
20000	-13.39	-	-
30000	-13.34	-	-
40000	-13.40	-	-

11K0F3E_940.55 MHz_ LOW POWER

Audio Frequency Response

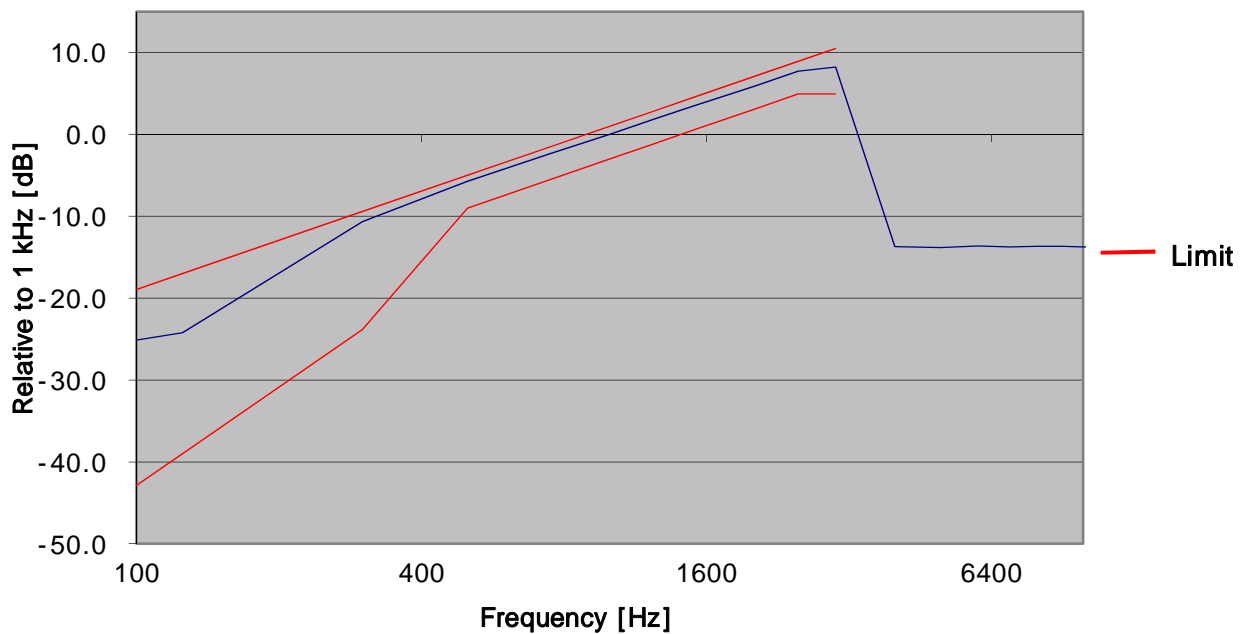

TEST RESULTS (14K0F3E)

Frequency (Hz)	Attenuation Rel. to 1kHz (dB)	Upper limit (dB)	Lower limit (dB)
100	-27.95	-18.93	-42.86
125	-28.33	-17.00	-39.00
300	-10.65	-9.42	-23.84
500	-5.84	-5.00	-9.00
750	-2.32	-1.49	-5.49
1000	0.00	1.00	-3.00
1250	1.94	2.93	-1.07
1500	3.52	4.51	0.51
2000	5.83	7.00	3.00
2500	7.76	8.93	4.93
3000	8.28	10.51	4.93
4000	-15.22	-	-
5000	-15.23	-	-
6000	-15.22	-	-
7000	-15.14	-	-
8000	-15.15	-	-
9000	-15.21	-	-
10000	-15.32	-	-
20000	-15.16	-	-
30000	-15.29	-	-
40000	-15.14	-	-

14K0F3E 806.05 MHz HIGH POWER

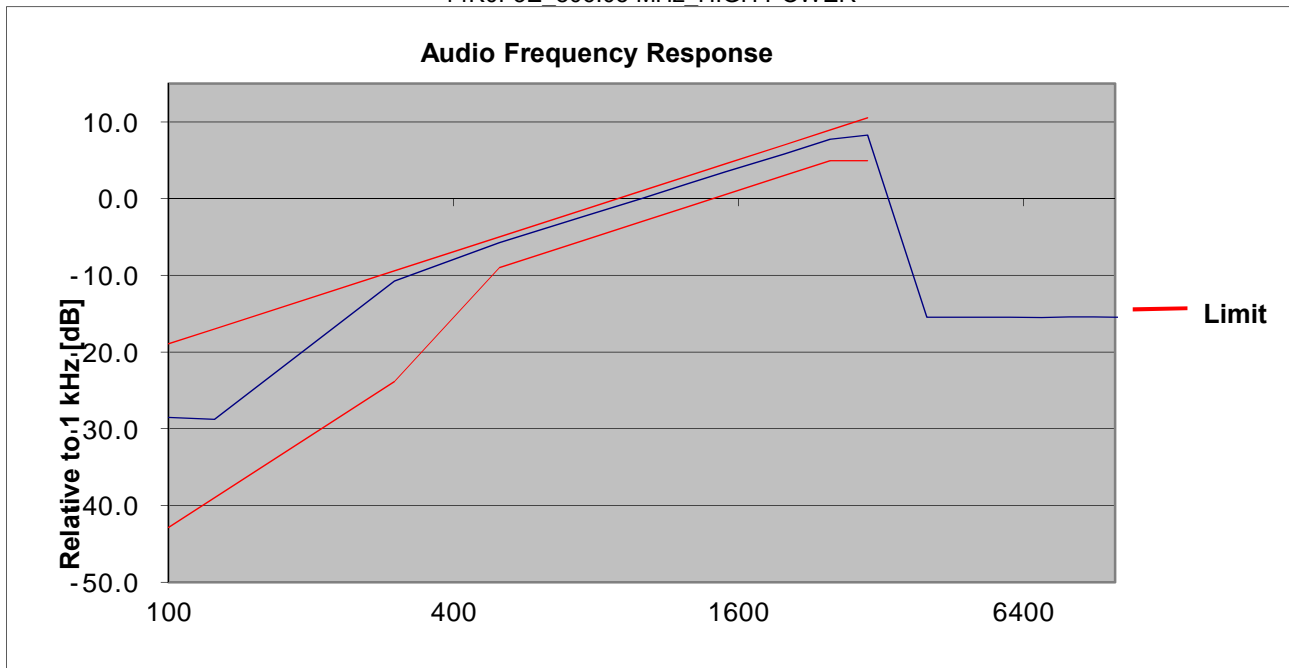

Frequency (Hz)	Attenuation Rel. to 1kHz (dB)	Upper limit (dB)	Lower limit (dB)
100	-28.66	-18.93	-42.86
125	-28.95	-17.00	-39.00
300	-10.70	-9.42	-23.84
500	-5.75	-5.00	-9.00
750	-2.39	-1.49	-5.49
1000	0.00	1.00	-3.00
1250	1.91	2.93	-1.07
1500	3.47	4.51	0.51
2000	5.82	7.00	3.00
2500	7.72	8.93	4.93
3000	8.23	10.51	4.93
4000	-15.69	-	-
5000	-15.79	-	-
6000	-15.53	-	-
7000	-15.68	-	-
8000	-15.65	-	-
9000	-15.66	-	-
10000	-15.73	-	-
20000	-15.66	-	-
30000	-15.55	-	-
40000	-15.73	-	-

14K0F3E_851.05 MHz_HIGH POWER

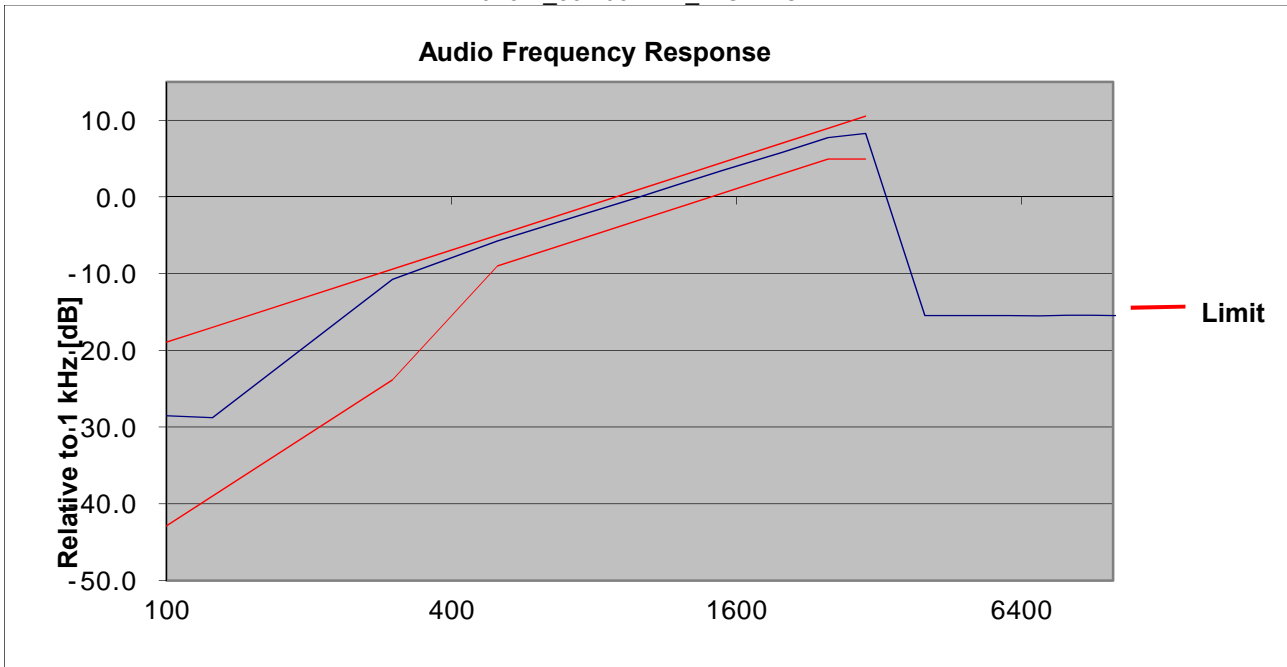

Frequency (Hz)	Attenuation Rel. to 1kHz (dB)	Upper limit (dB)	Lower limit (dB)
100	-28.38	-18.93	-42.86
125	-28.52	-17.00	-39.00
300	-10.64	-9.42	-23.84
500	-5.75	-5.00	-9.00
750	-2.38	-1.49	-5.49
1000	0.00	1.00	-3.00
1250	1.93	2.93	-1.07
1500	3.45	4.51	0.51
2000	5.82	7.00	3.00
2500	7.74	8.93	4.93
3000	8.25	10.51	4.93
4000	-15.47	-	-
5000	-15.46	-	-
6000	-15.44	-	-
7000	-15.53	-	-
8000	-15.46	-	-
9000	-15.44	-	-
10000	-15.49	-	-
20000	-15.41	-	-
30000	-15.50	-	-
40000	-15.46	-	-

14K0F3E_868.95 MHz_HIGH POWER

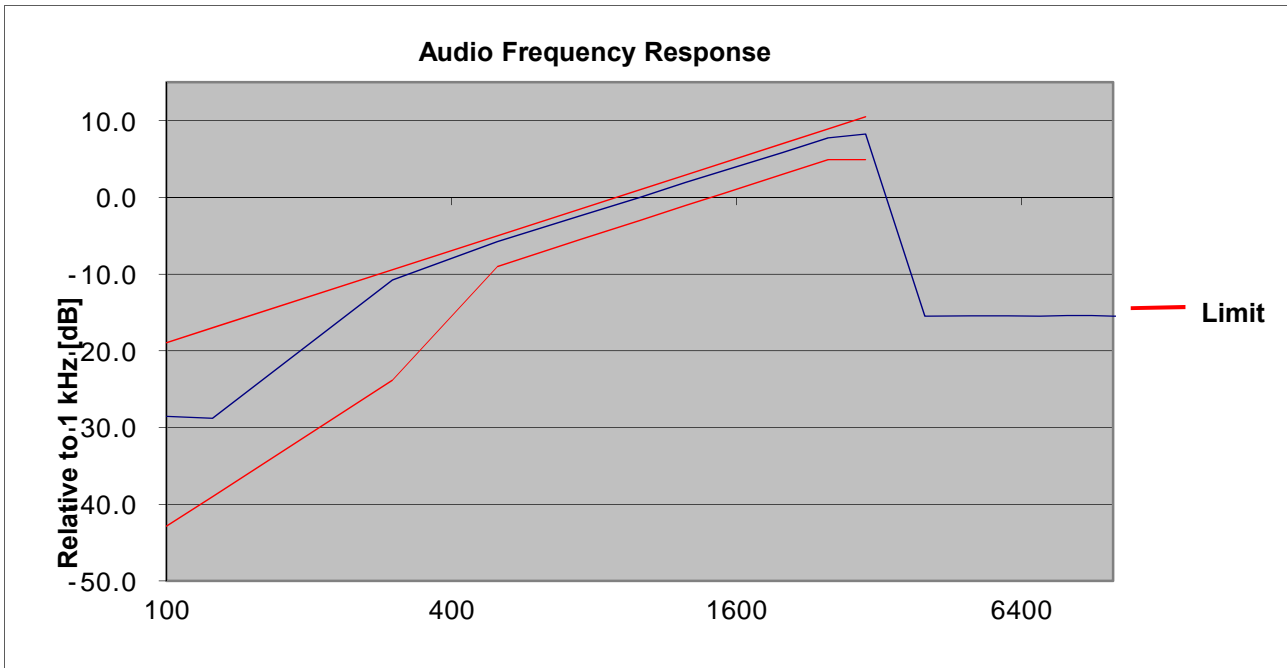

Frequency (Hz)	Attenuation Rel. to 1kHz (dB)	Upper limit (dB)	Lower limit (dB)
100	-29.19	-18.93	-42.86
125	-29.19	-17.00	-39.00
300	-10.70	-9.42	-23.84
500	-5.73	-5.00	-9.00
750	-2.37	-1.49	-5.49
1000	0.00	1.00	-3.00
1250	1.93	2.93	-1.07
1500	3.46	4.51	0.51
2000	5.81	7.00	3.00
2500	7.70	8.93	4.93
3000	8.20	10.51	4.93
4000	-15.98	-	-
5000	-15.96	-	-
6000	-15.95	-	-
7000	-16.02	-	-
8000	-16.05	-	-
9000	-16.01	-	-
10000	-15.93	-	-
20000	-15.99	-	-
30000	-15.95	-	-
40000	-15.99	-	-

14K0F3E_806.05 MHz_LOW POWER

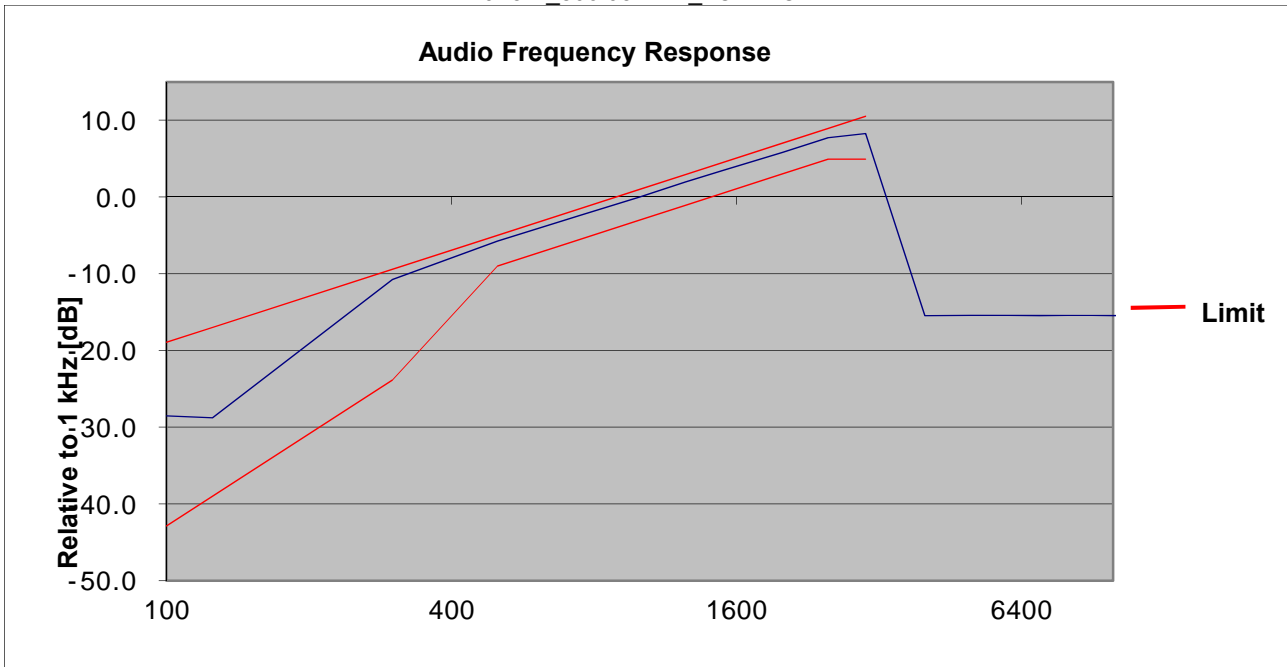

Frequency (Hz)	Attenuation Rel. to 1kHz (dB)	Upper limit (dB)	Lower limit (dB)
100	-28.73	-18.93	-42.86
125	-28.95	-17.00	-39.00
300	-10.74	-9.42	-23.84
500	-5.77	-5.00	-9.00
750	-2.38	-1.49	-5.49
1000	0.00	1.00	-3.00
1250	1.91	2.93	-1.07
1500	3.45	4.51	0.51
2000	5.82	7.00	3.00
2500	7.72	8.93	4.93
3000	8.23	10.51	4.93
4000	-15.68	-	-
5000	-15.64	-	-
6000	-15.71	-	-
7000	-15.63	-	-
8000	-15.74	-	-
9000	-15.68	-	-
10000	-15.76	-	-
20000	-15.69	-	-
30000	-15.74	-	-
40000	-15.64	-	-

14K0F3E_851.05 MHz_ LOW POWER

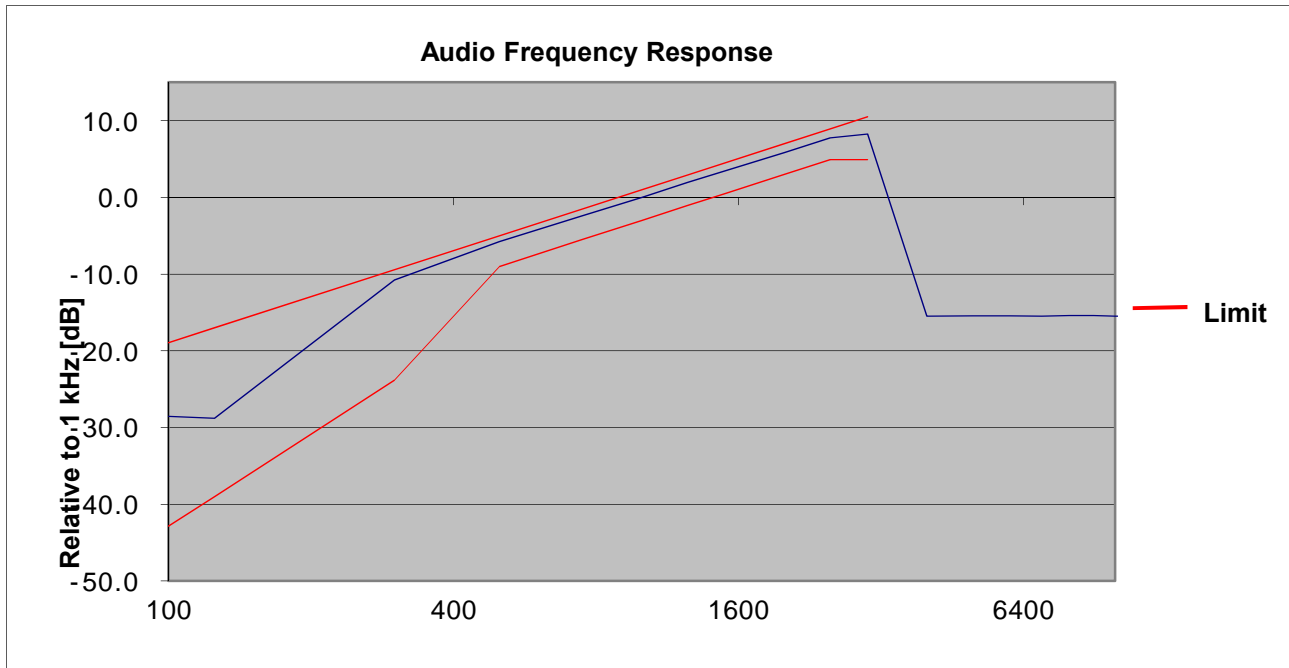

Frequency (Hz)	Attenuation Rel. to 1kHz (dB)	Upper limit (dB)	Lower limit (dB)
100	-28.52	-18.93	-42.86
125	-28.78	-17.00	-39.00
300	-10.75	-9.42	-23.84
500	-5.76	-5.00	-9.00
750	-2.38	-1.49	-5.49
1000	0.00	1.00	-3.00
1250	1.95	2.93	-1.07
1500	3.47	4.51	0.51
2000	5.82	7.00	3.00
2500	7.74	8.93	4.93
3000	8.26	10.51	4.93
4000	-15.48	-	-
5000	-15.45	-	-
6000	-15.45	-	-
7000	-15.49	-	-
8000	-15.42	-	-
9000	-15.42	-	-
10000	-15.48	-	-
20000	-15.44	-	-
30000	-15.49	-	-
40000	-15.53	-	-

14K0F3E_868.95 MHz_LOW POWER

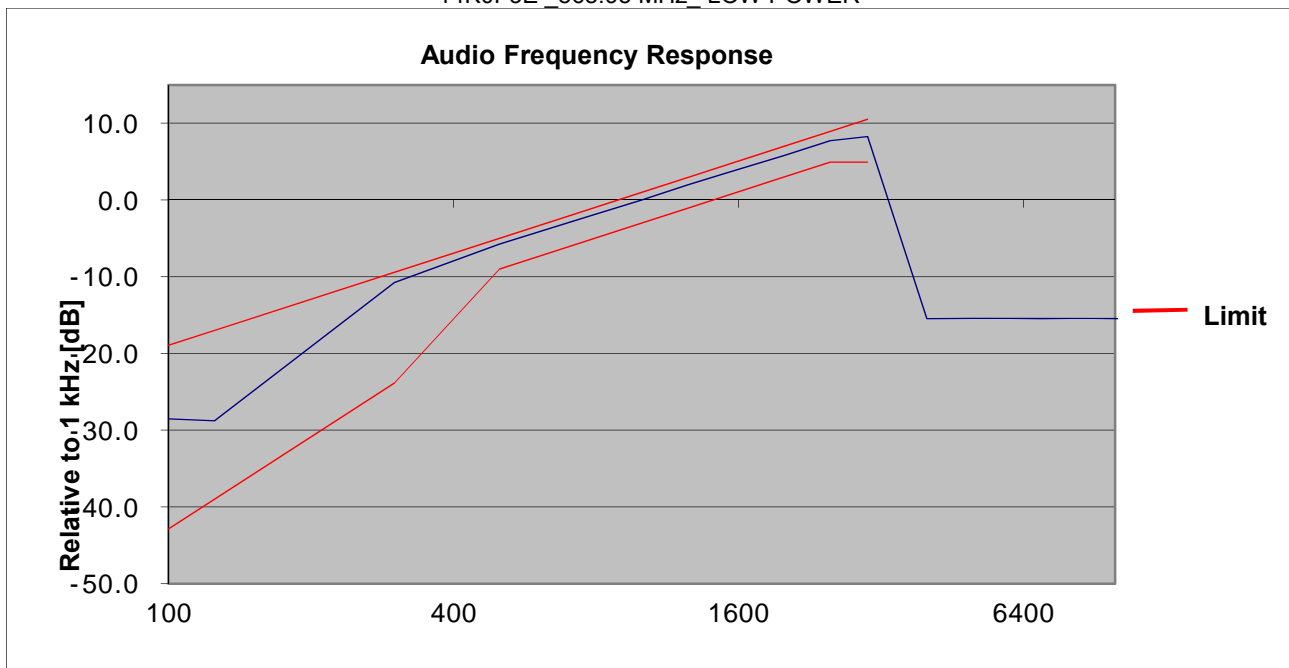

TEST RESULTS (16K0F3E)

Frequency (Hz)	Attenuation Rel. to 1kHz (dB)	Upper limit (dB)	Lower limit (dB)
100	-30.93	-18.93	-42.86
125	-30.93	-17.00	-39.00
300	-10.68	-9.42	-23.84
500	-5.76	-5.00	-9.00
750	-2.35	-1.49	-5.49
1000	0.00	1.00	-3.00
1250	1.90	2.93	-1.07
1500	3.43	4.51	0.51
2000	5.79	7.00	3.00
2500	7.69	8.93	4.93
3000	8.20	10.51	4.93
4000	-18.05	-	-
5000	-17.85	-	-
6000	-17.79	-	-
7000	-17.99	-	-
8000	-17.95	-	-
9000	-17.92	-	-
10000	-17.80	-	-
20000	-17.97	-	-
30000	-17.90	-	-
40000	-18.05	-	-

16K0F3E 806.05 MHz HIGH POWER

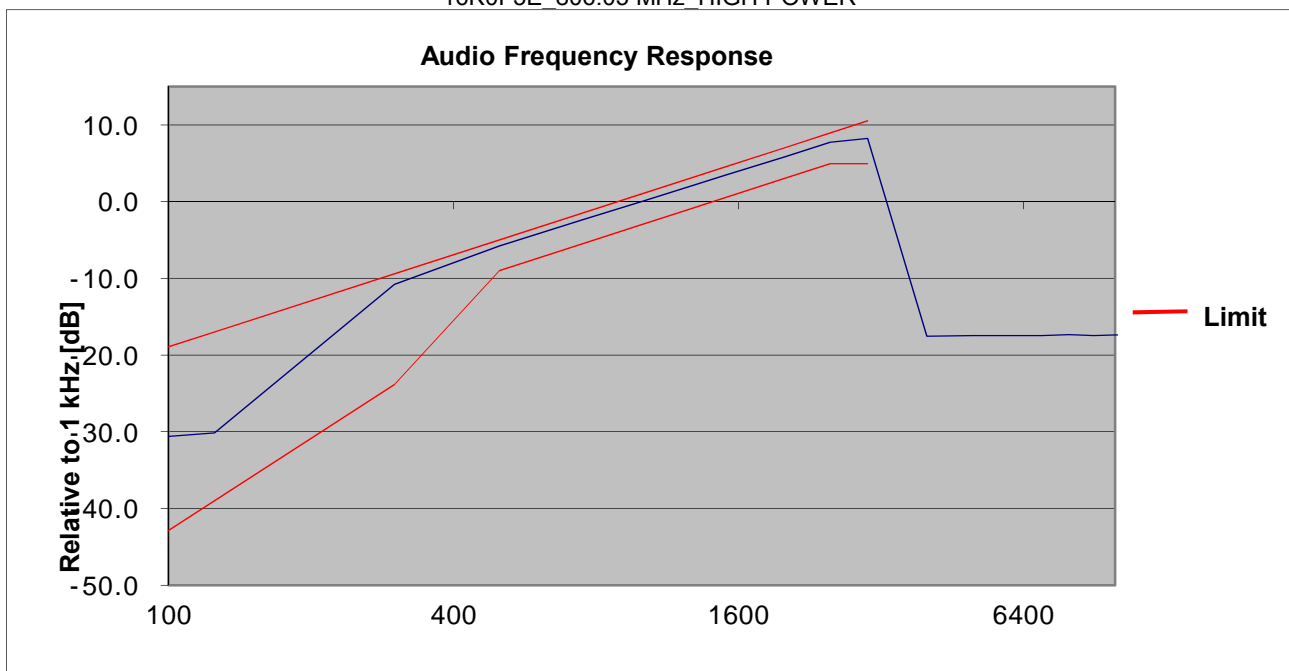

Frequency (Hz)	Attenuation Rel. to 1kHz (dB)	Upper limit (dB)	Lower limit (dB)
100	-30.66	-18.93	-42.86
125	-30.66	-17.00	-39.00
300	-10.77	-9.42	-23.84
500	-5.80	-5.00	-9.00
750	-2.37	-1.49	-5.49
1000	0.00	1.00	-3.00
1250	1.90	2.93	-1.07
1500	3.44	4.51	0.51
2000	5.81	7.00	3.00
2500	7.72	8.93	4.93
3000	8.23	10.51	4.93
4000	-17.65	-	-
5000	-17.56	-	-
6000	-17.73	-	-
7000	-17.56	-	-
8000	-17.64	-	-
9000	-17.57	-	-
10000	-17.56	-	-
20000	-17.59	-	-
30000	-17.58	-	-
40000	-17.60	-	-

16K0F3E_851.05 MHz_HIGH POWER

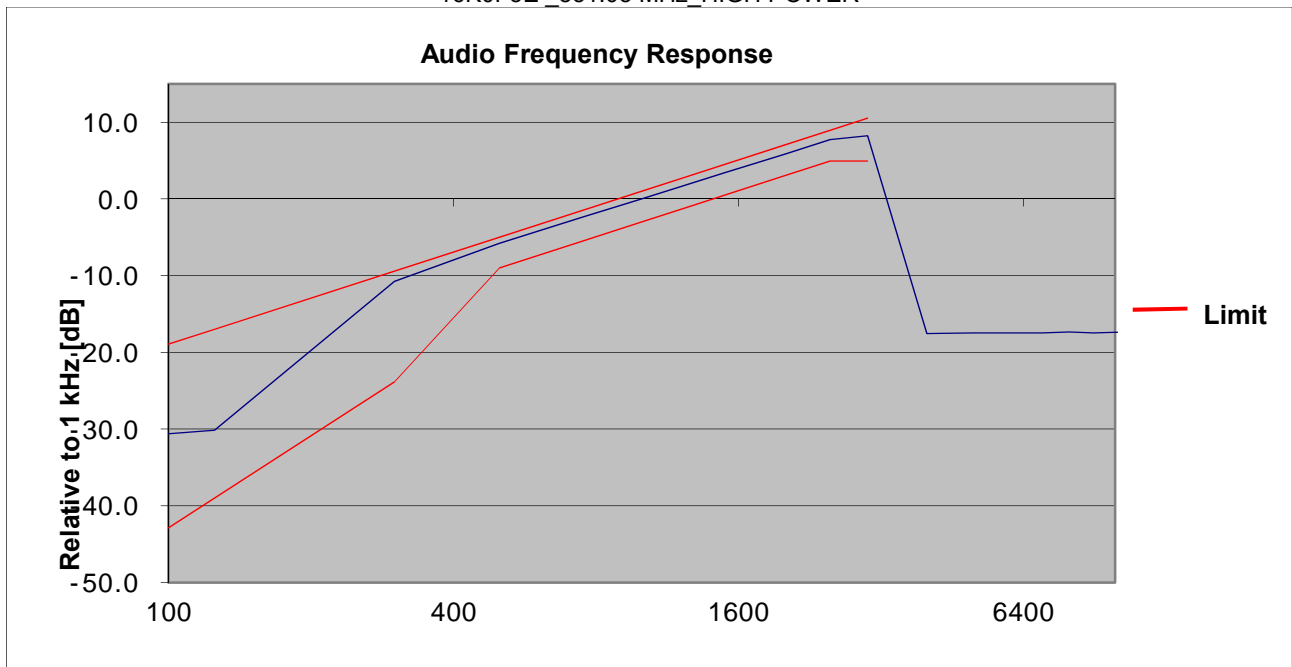

Frequency (Hz)	Attenuation Rel. to 1kHz (dB)	Upper limit (dB)	Lower limit (dB)
100	-30.60	-18.93	-42.86
125	-30.14	-17.00	-39.00
300	-10.77	-9.42	-23.84
500	-5.80	-5.00	-9.00
750	-2.38	-1.49	-5.49
1000	0.00	1.00	-3.00
1250	1.90	2.93	-1.07
1500	3.44	4.51	0.51
2000	5.81	7.00	3.00
2500	7.72	8.93	4.93
3000	8.23	10.51	4.93
4000	-17.55	-	-
5000	-17.46	-	-
6000	-17.47	-	-
7000	-17.47	-	-
8000	-17.34	-	-
9000	-17.48	-	-
10000	-17.39	-	-
20000	-17.48	-	-
30000	-17.45	-	-
40000	-17.41	-	-

16K0F3E _868.95 MHz_HIGH POWER

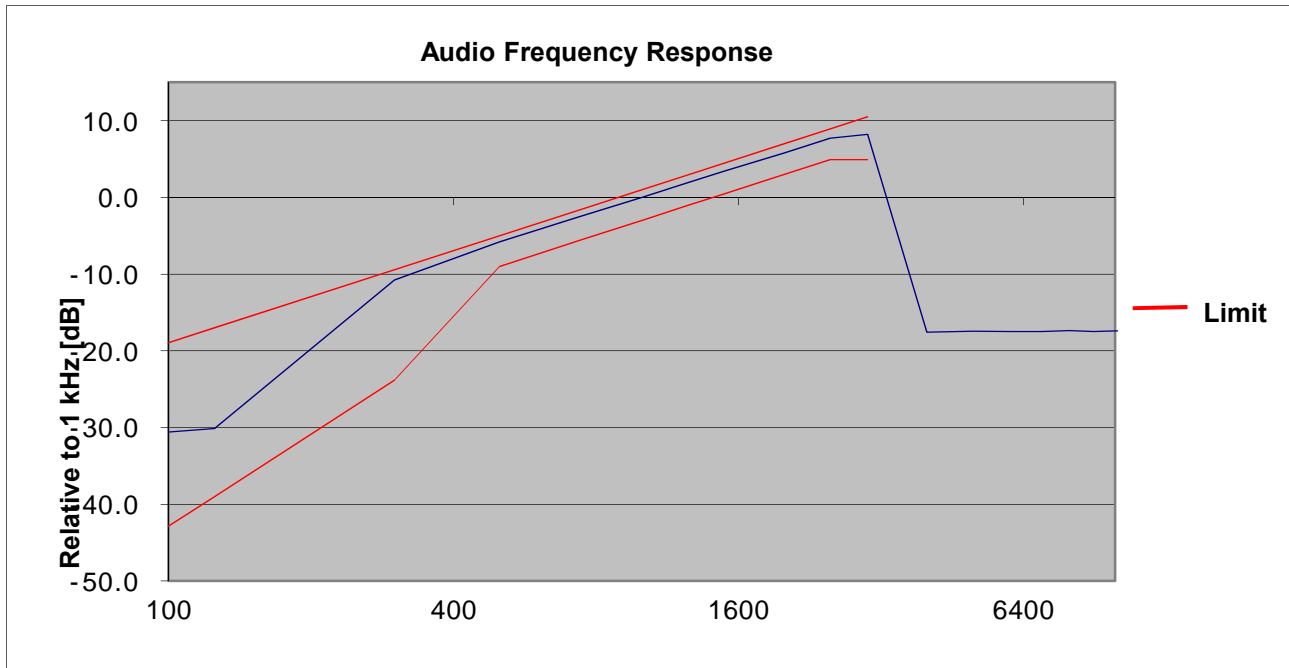

Frequency (Hz)	Attenuation Rel. to 1kHz (dB)	Upper limit (dB)	Lower limit (dB)
100	-30.90	-18.93	-42.86
125	-31.09	-17.00	-39.00
300	-10.67	-9.42	-23.84
500	-5.76	-5.00	-9.00
750	-2.37	-1.49	-5.49
1000	0.00	1.00	-3.00
1250	1.93	2.93	-1.07
1500	3.45	4.51	0.51
2000	5.81	7.00	3.00
2500	7.70	8.93	4.93
3000	8.20	10.51	4.93
4000	-18.03	-	-
5000	-17.90	-	-
6000	-17.89	-	-
7000	-17.87	-	-
8000	-17.97	-	-
9000	-17.90	-	-
10000	-18.03	-	-
20000	-17.94	-	-
30000	-18.01	-	-
40000	-17.93	-	-

16K0F3E_806.05 MHz_LOW POWER

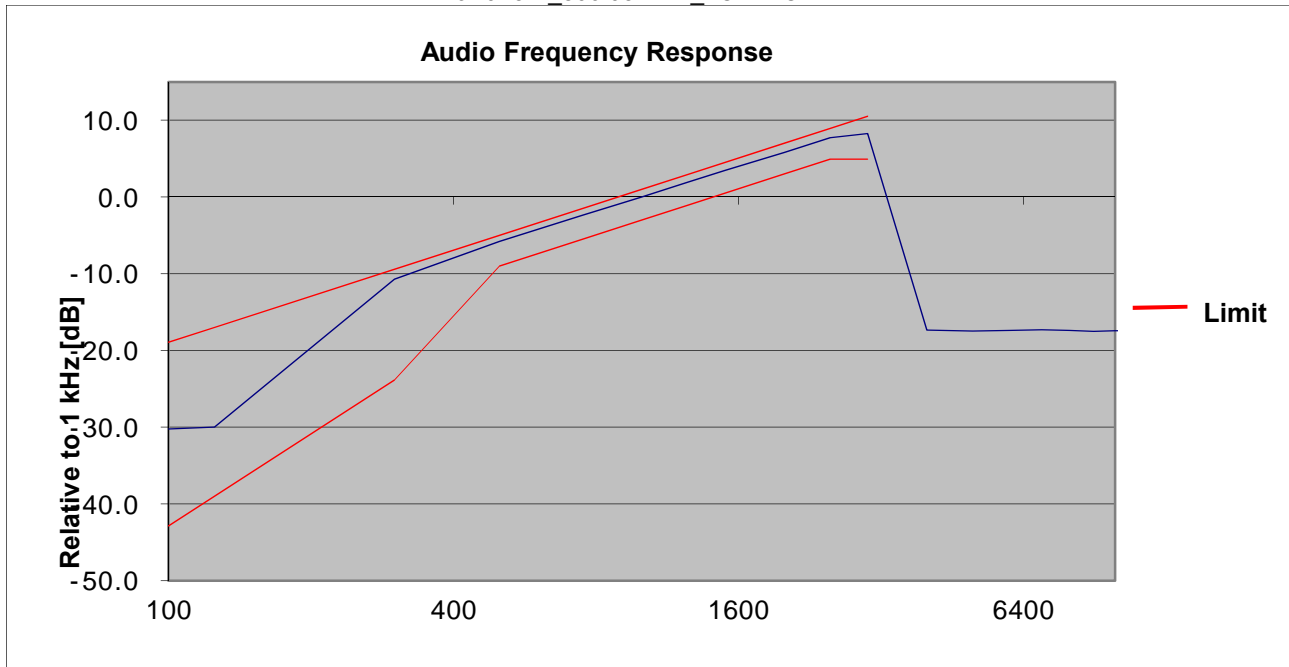

Frequency (Hz)	Attenuation Rel. to 1kHz (dB)	Upper limit (dB)	Lower limit (dB)
100	-30.34	-18.93	-42.86
125	-30.25	-17.00	-39.00
300	-10.70	-9.42	-23.84
500	-5.80	-5.00	-9.00
750	-2.39	-1.49	-5.49
1000	0.00	1.00	-3.00
1250	1.91	2.93	-1.07
1500	3.44	4.51	0.51
2000	5.82	7.00	3.00
2500	7.72	8.93	4.93
3000	8.24	10.51	4.93
4000	-17.50	-	-
5000	-17.57	-	-
6000	-17.73	-	-
7000	-17.55	-	-
8000	-17.67	-	-
9000	-17.59	-	-
10000	-17.63	-	-
20000	-17.69	-	-
30000	-17.69	-	-
40000	-17.67	-	-

16K0F3E_851.05 MHz_ LOW POWER

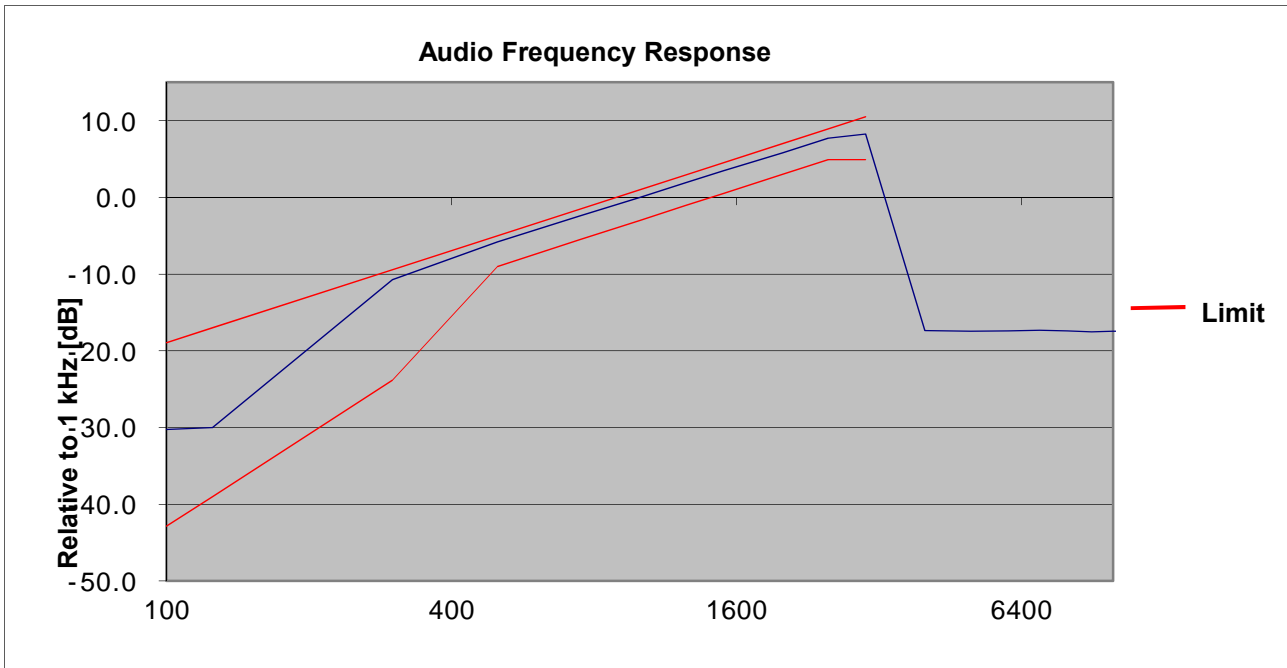

Frequency (Hz)	Attenuation Rel. to 1kHz (dB)	Upper limit (dB)	Lower limit (dB)
100	-30.25	-18.93	-42.86
125	-29.98	-17.00	-39.00
300	-10.73	-9.42	-23.84
500	-5.80	-5.00	-9.00
750	-2.38	-1.49	-5.49
1000	0.00	1.00	-3.00
1250	1.91	2.93	-1.07
1500	3.45	4.51	0.51
2000	5.81	7.00	3.00
2500	7.72	8.93	4.93
3000	8.25	10.51	4.93
4000	-17.34	-	-
5000	-17.46	-	-
6000	-17.39	-	-
7000	-17.32	-	-
8000	-17.41	-	-
9000	-17.51	-	-
10000	-17.45	-	-
20000	-17.51	-	-
30000	-17.35	-	-
40000	-17.45	-	-

16K0F3E_868.95 MHz_LOW POWER

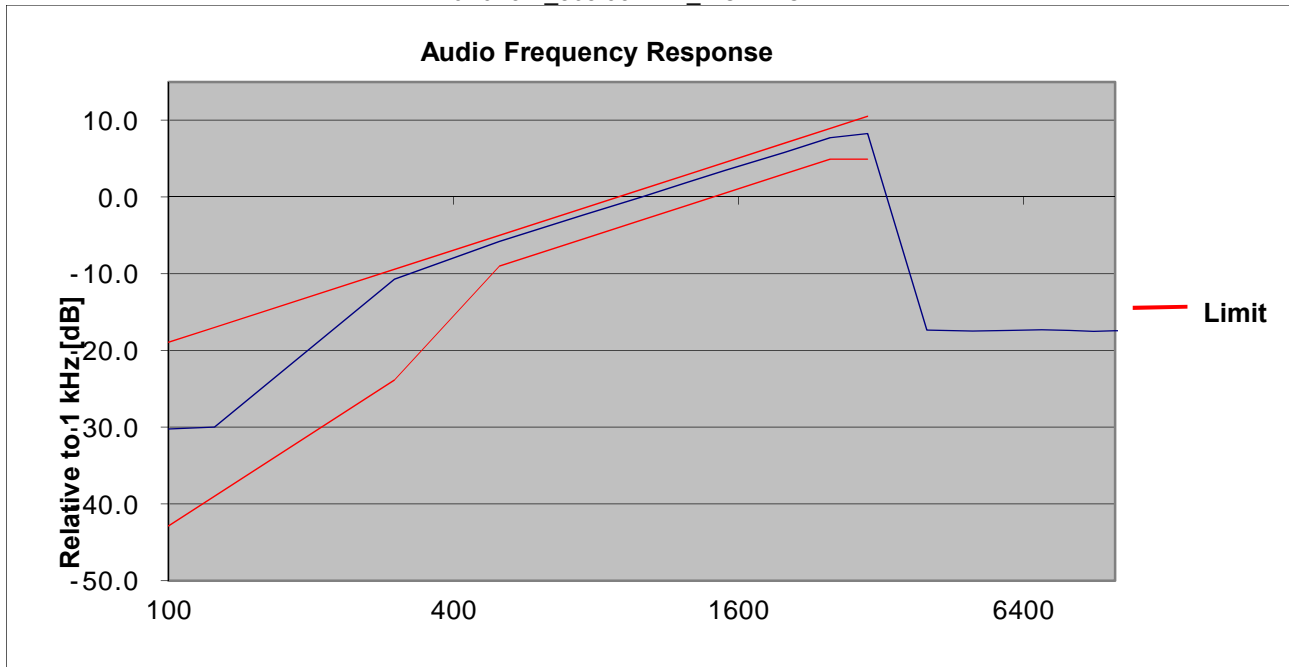

10.6 Emission Mask

Definition

The transmitter sideband spectrum denotes the sideband power produced at a discrete frequency separation from the carrier up to the test bandwidth (see 1.3.4.4) due to all sources of unwanted noise within the transmitter in a modulated condition.

TEST CONFIGURATION

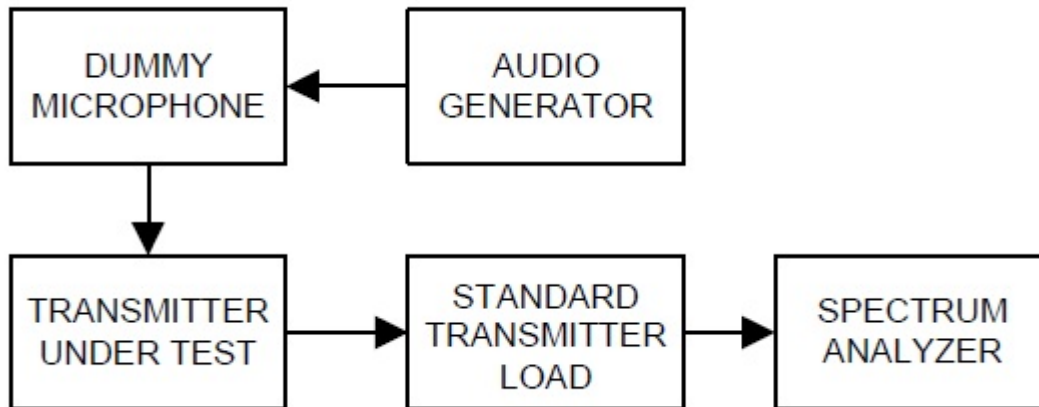

TEST PROCEDURE

According to 2.2.11 in TIA-603-E Standard.

- a) Connect the equipment as illustrated. Use the table to determine the spectrum analyzer resolution bandwidth:

Frequency Band (MHz)	Mask for Equipment with Audio Low Pass Filter	Mask for Equipment without Low Pass Filter	Spectrum Analyzer Resolution Bandwidth (Hz)
25-50	B	C	300
72-76	B	C	300
138-174	NTIA	NTIA	300
150-174	B	C	300
150-174	D or E	D or E	100
406-420	NTIA	NTIA	300
421-512	B	C	300
421-512	D or E	D or E	100
806-821/851-866	B or EA	G or EA	300
821-824/866-869	B	H	300
896-901/935-940	I	J	300

- b) Adjust the spectrum analyzer for the following settings:
 - 1) Resolution Bandwidth per the above table
 - 2) Video Bandwidth at least 10 times the resolution bandwidth.
 - 3) Sweep Speed slow enough to maintain measurement calibration.
 - 4) Detector Mode = Positive Peak.
 - 5) Span that will allow proper viewing of the test bandwidth (see 1.3.4.4).
- c) Set the center frequency of the spectrum analyzer to the assigned transmitter frequency. Key the transmitter, and set the level of the unmodulated carrier to a full scale reference line.
This is the 0 dB reference for the measurement.
- d) Modulate the transmitter with a 2500 Hz sine wave at an input level 16 dB greater than that necessary to produce 50% of rated system deviation. The input level shall be established at the frequency of maximum response of the audio modulating circuit. Transmitters employing digital modulation techniques that bypass the limiter and the audio low-pass filter shall be modulated as specified by the manufacturer.
- e) Record the resulting spectrum analyzer presentation of the emission level with an on-line recording device or in a photograph. It is recommended that the emission limit (as given in 3.2.11) be drawn on the plotted graph or photograph. The spectrum analyzer presentation is the sideband spectrum.

10.6.1 Emission Mask EA(§90.691)

(11K0F3E _ 815.05 MHz)_High

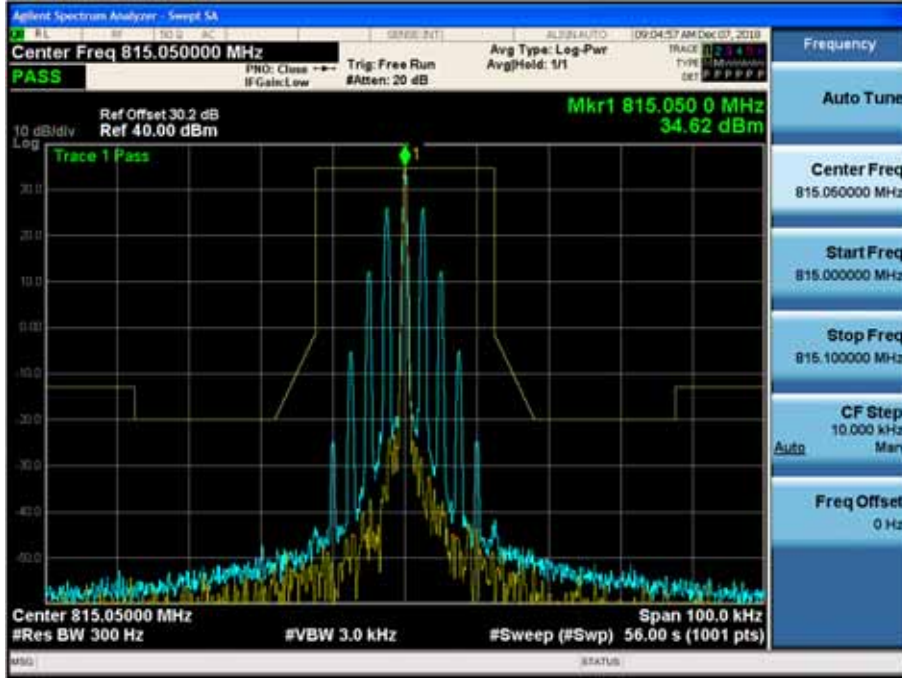

(11K0F3E _ 823.95 MHz)_High

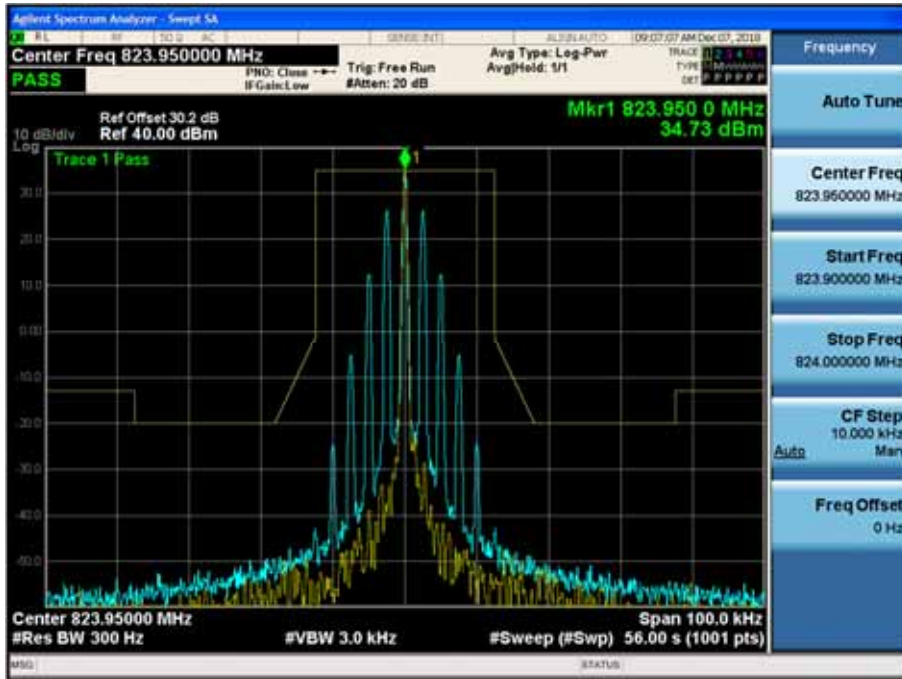

(11K0F3E _ 860.05 MHz)_High

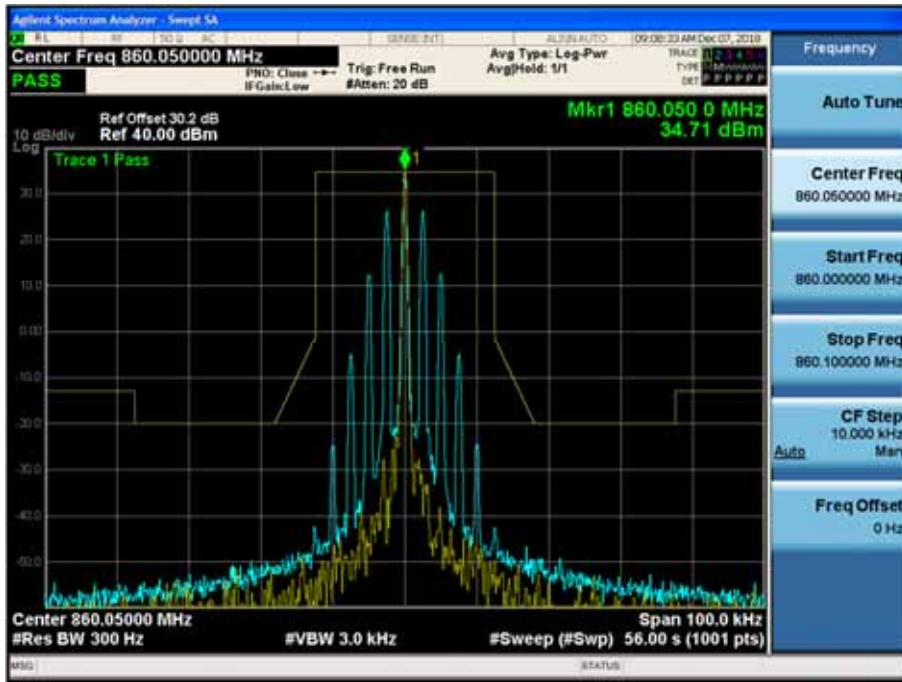

(11K0F3E _ 868.95 MHz)_High

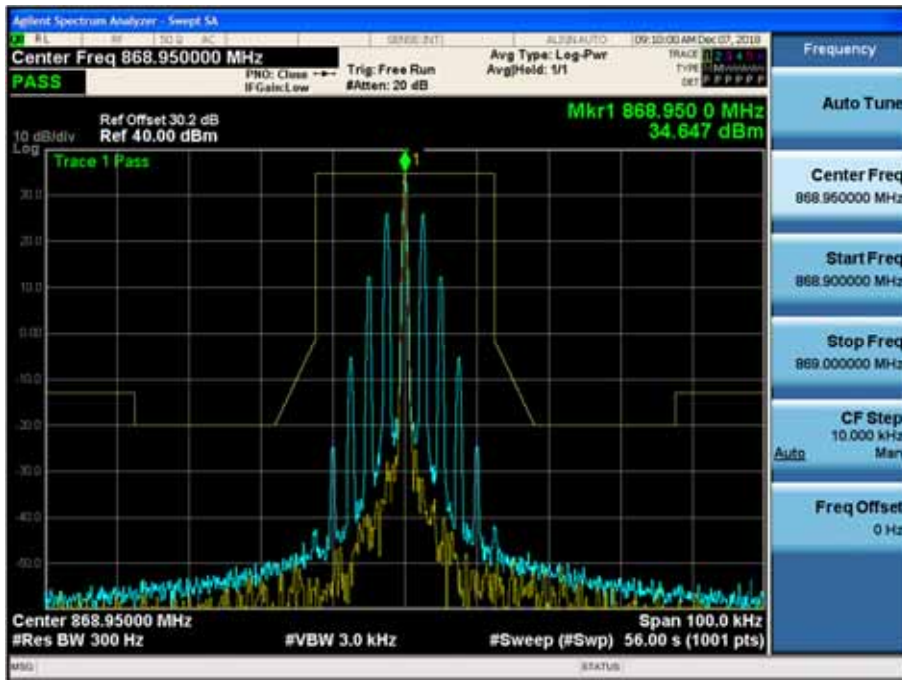

(11K0F3E _ 815.05 MHz)_ Low

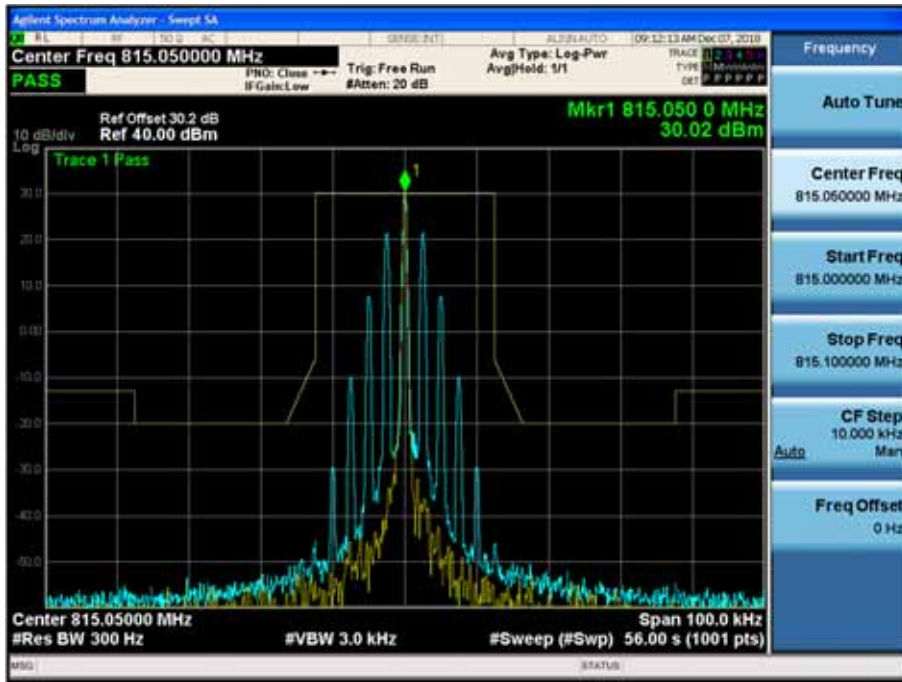

(11K0F3E _ 823.95 MHz)_ Low

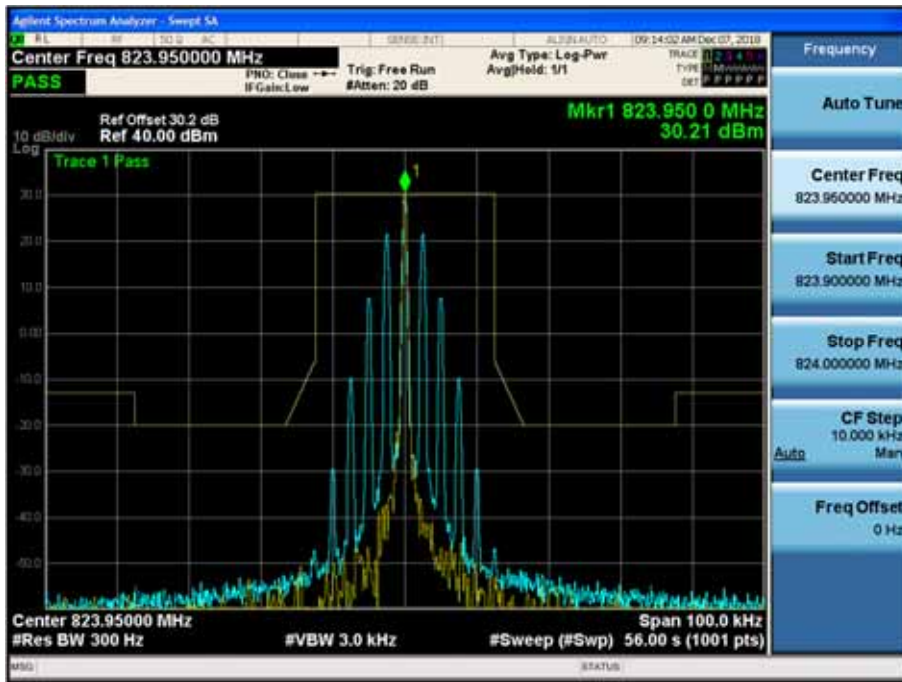

(11K0F3E _ 860.05 MHz)_ Low

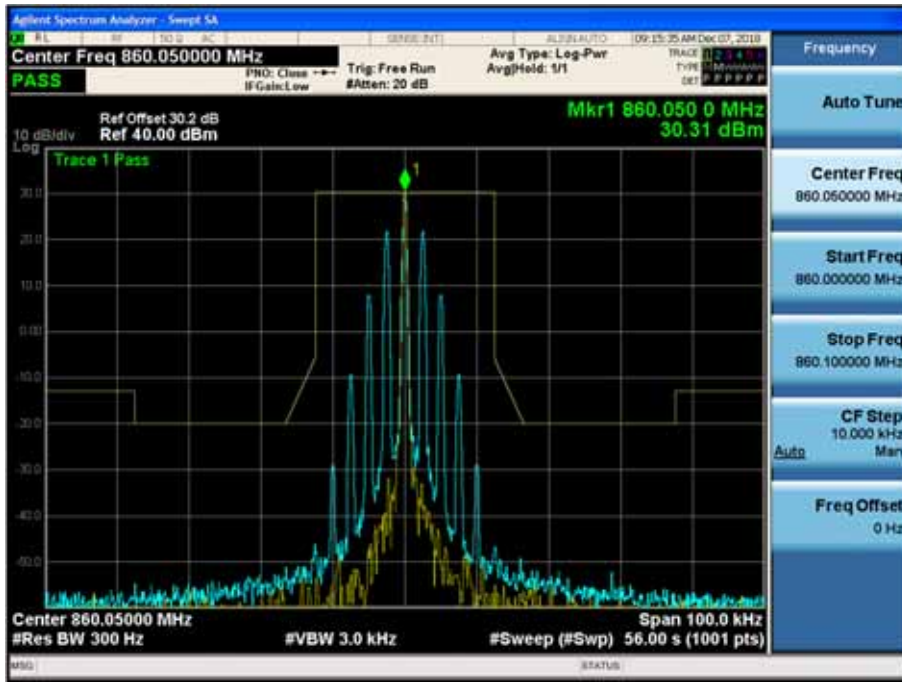

(11K0F3E _ 868.95 MHz)_ Low

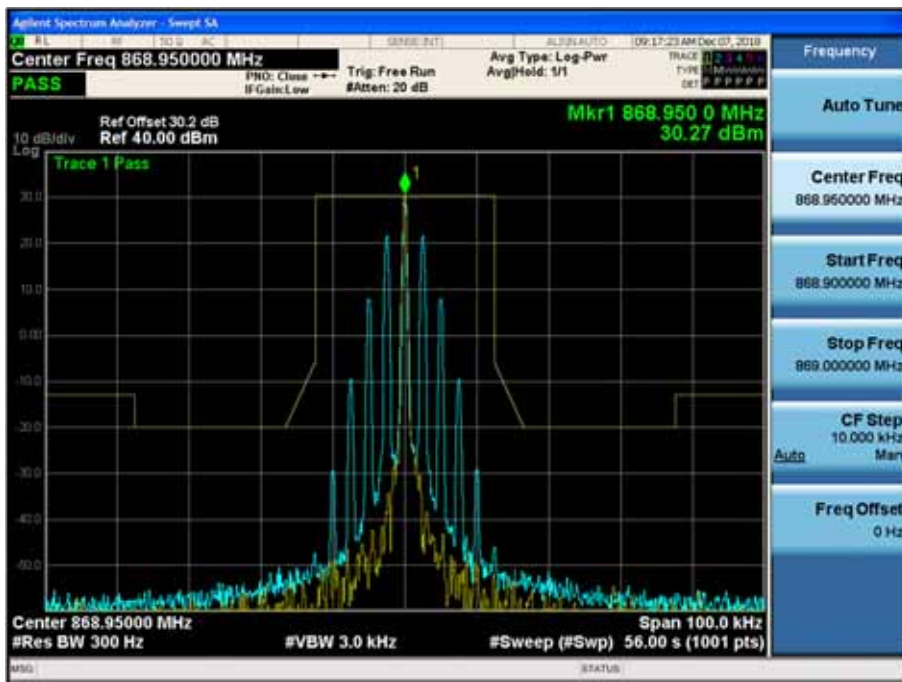

(14K0F3E _ 815.05 MHz)_High

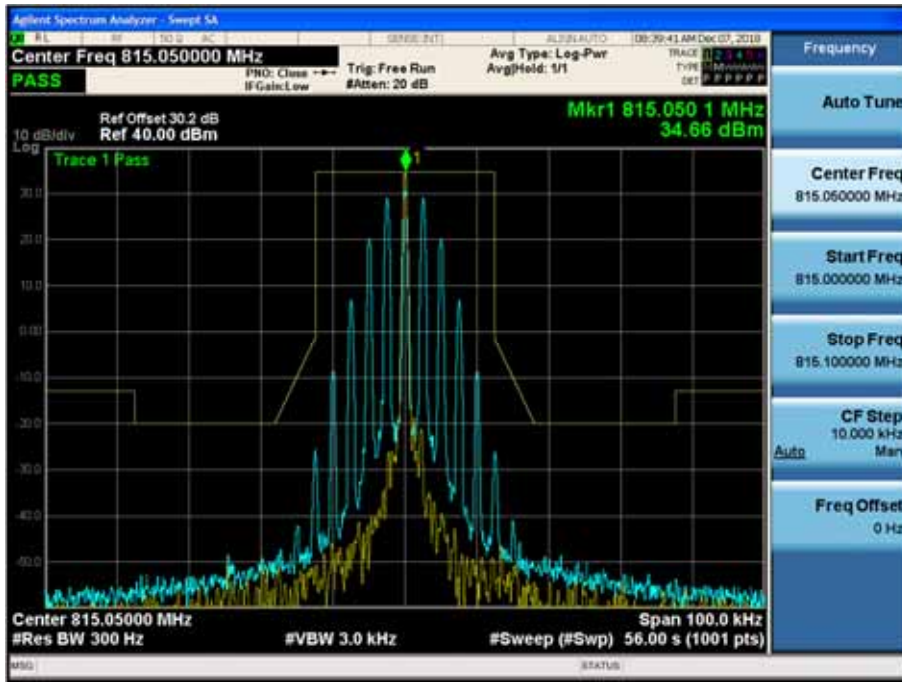

(14K0F3E _ 823.95 MHz)_High

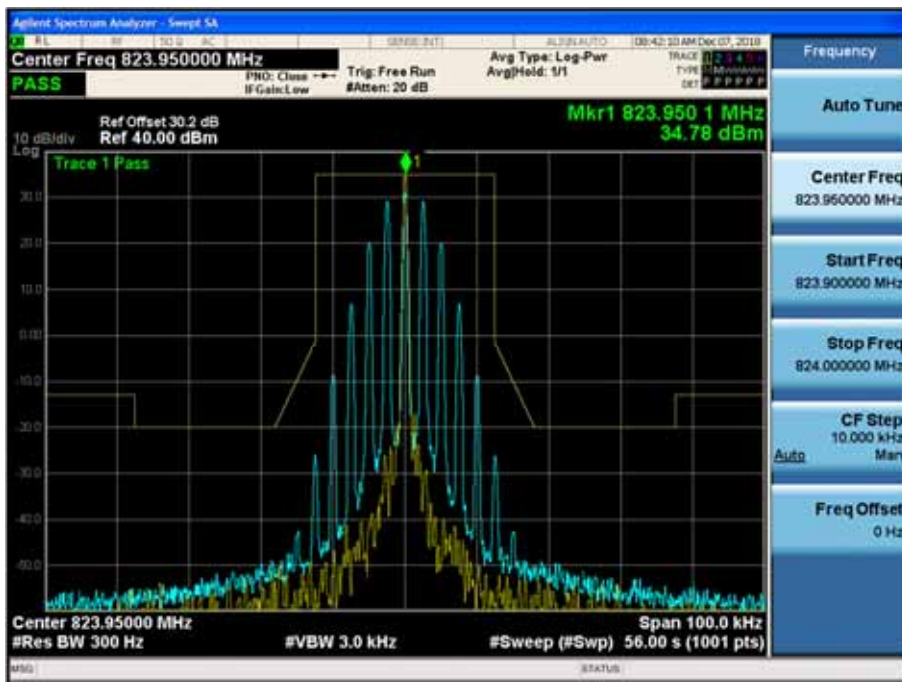

(14K0F3E _ 860.05 MHz)_High

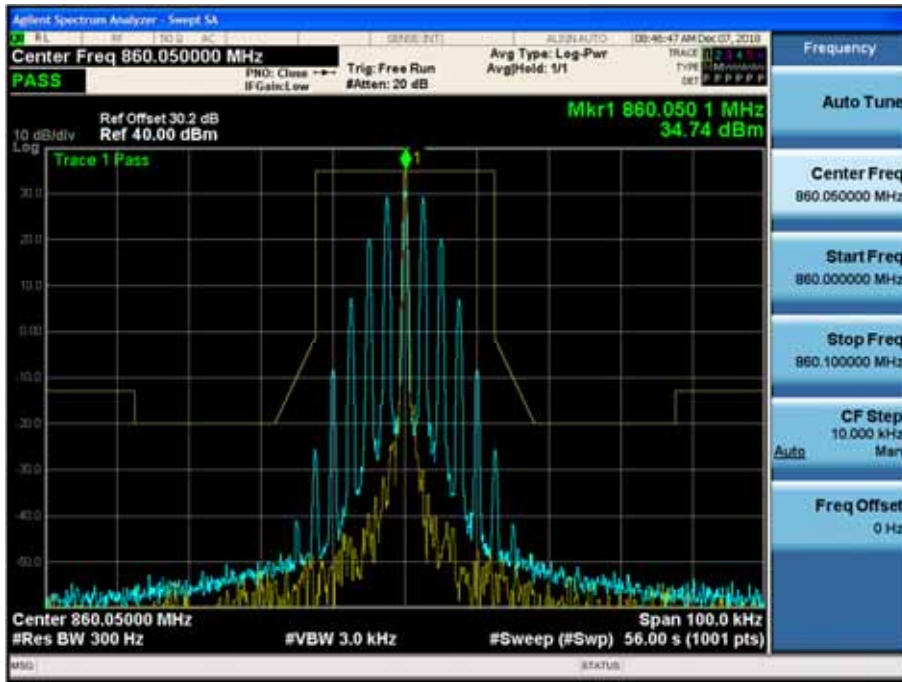

(14K0F3E _ 868.95 MHz)_High

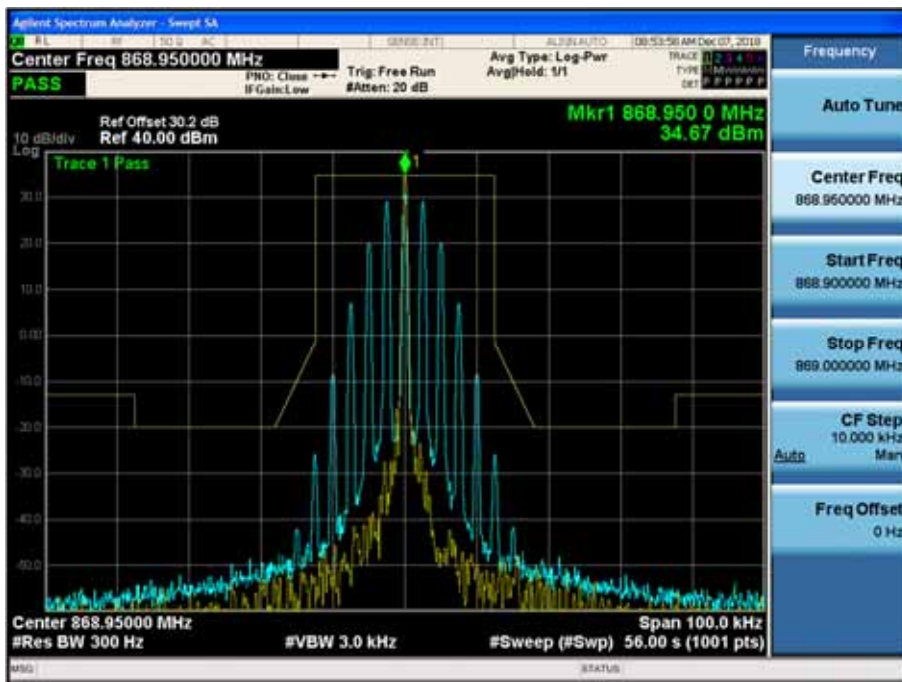

(14K0F3E _ 815.05 MHz)_Low

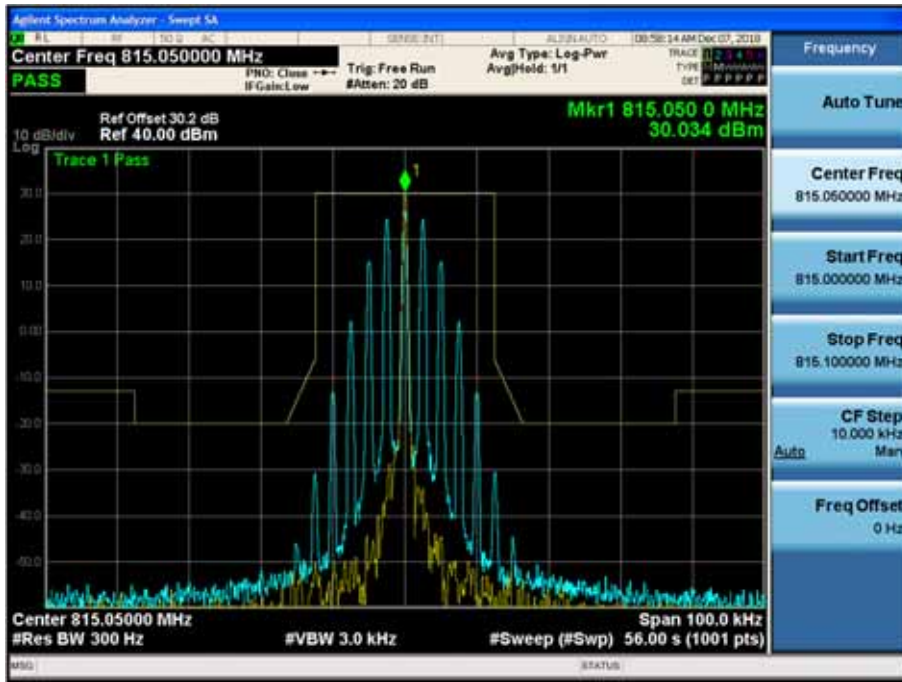

(14K0F3E _ 823.95 MHz)_Low

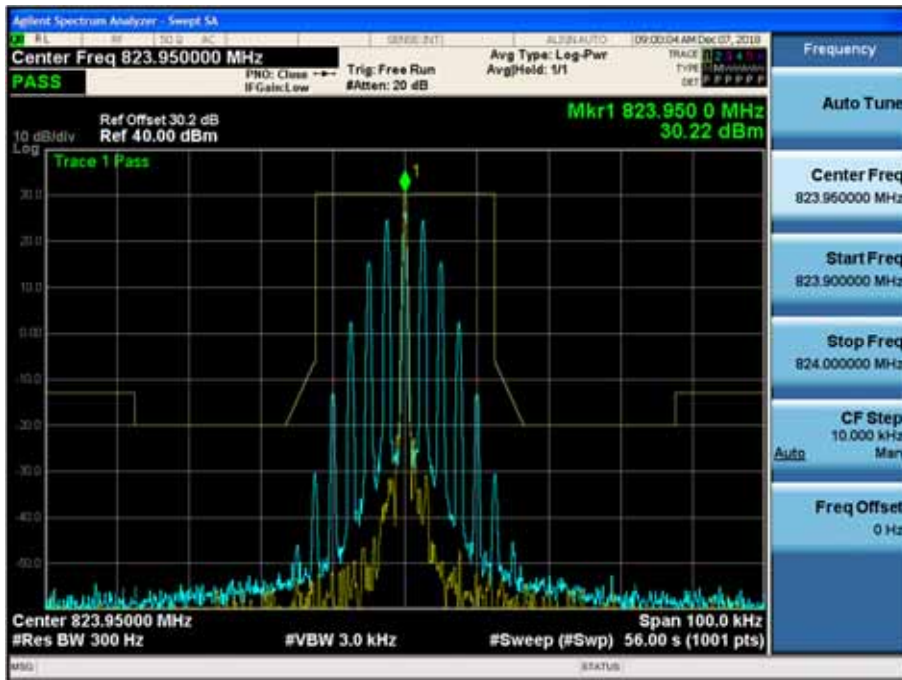

(14K0F3E _ 860.05 MHz)_Low

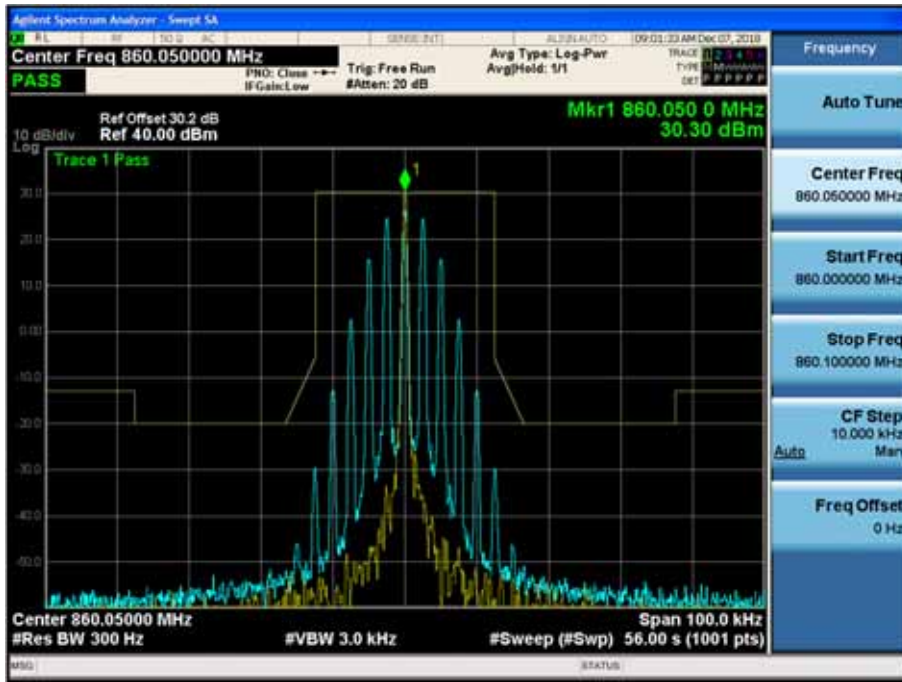

(14K0F3E _ 868.95 MHz)_Low

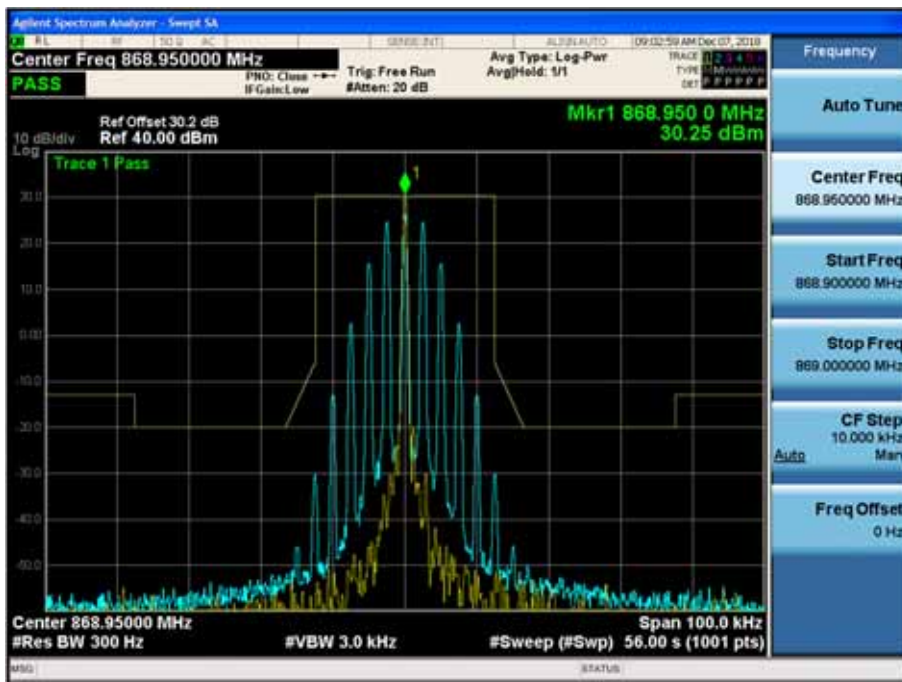

(16K0F3E _ 815.05 MHz)_High

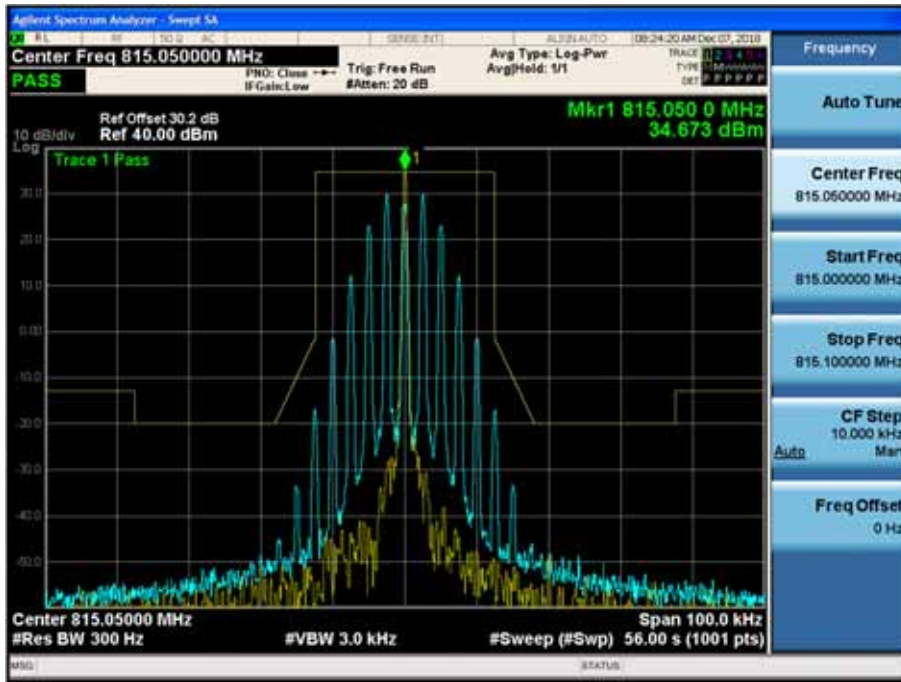

(16K0F3E _ 823.95 MHz)_High

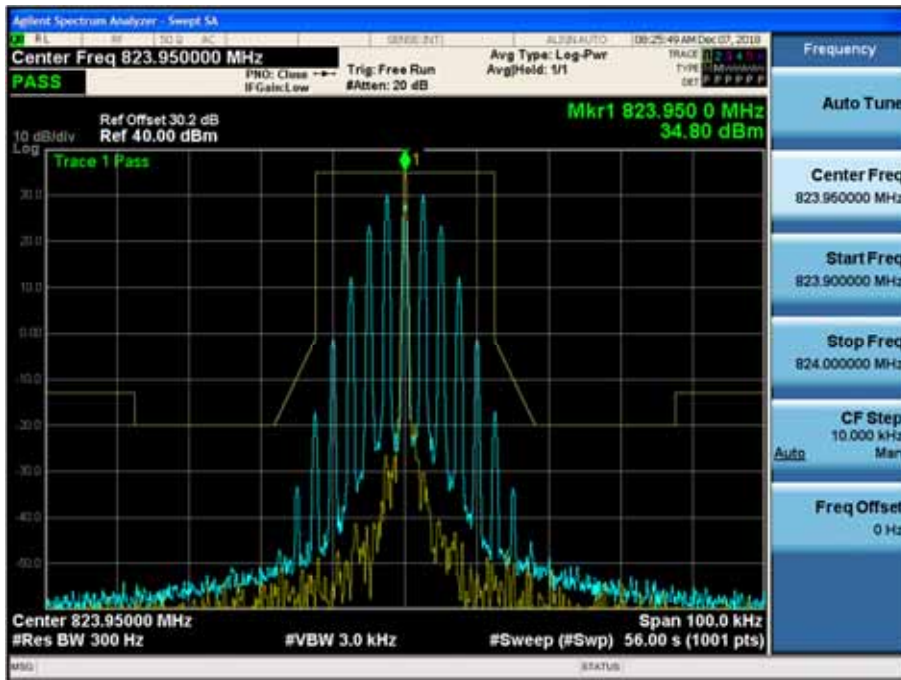

(16K0F3E _ 860.05 MHz)_High

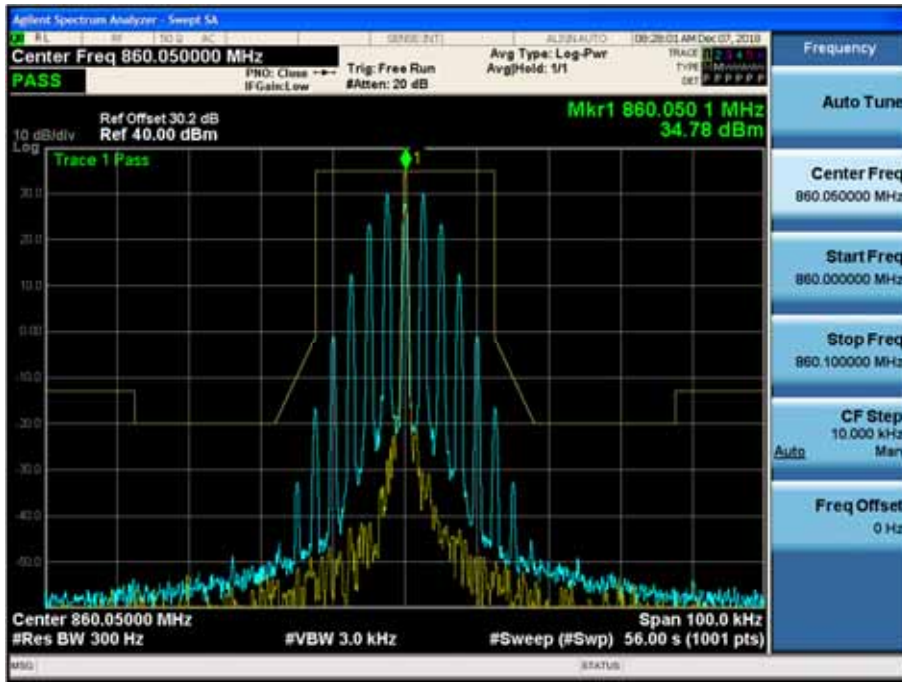

(16K0F3E _ 868.95 MHz)_High

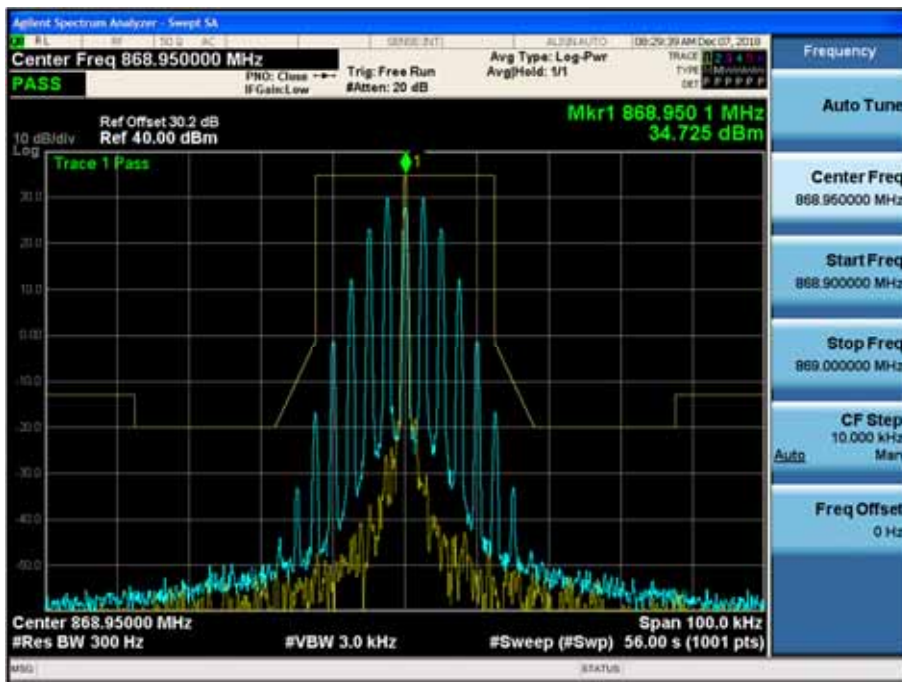

(16K0F3E _ 815.05 MHz)_Low

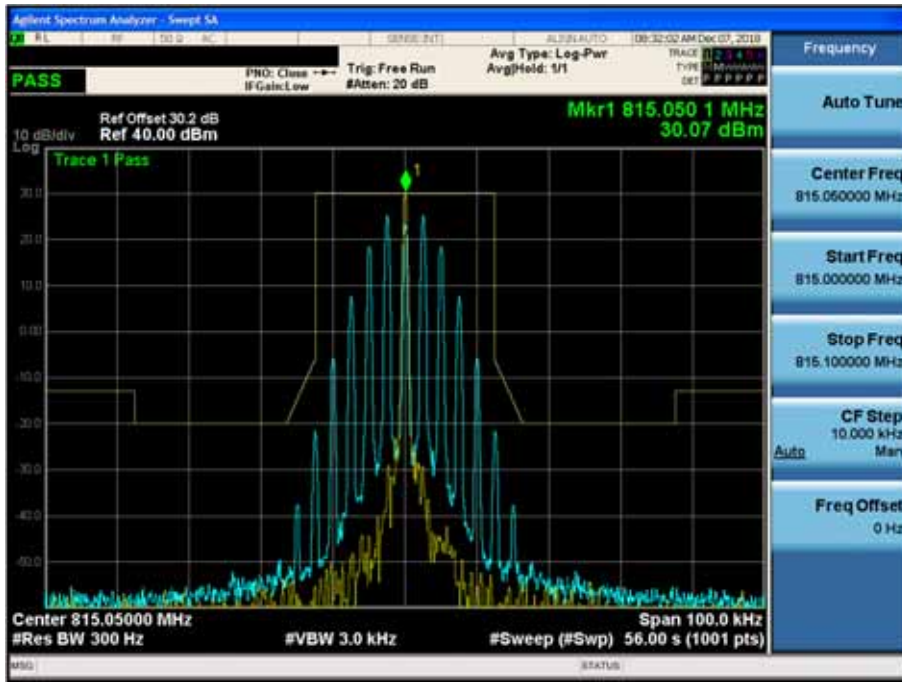

(16K0F3E _ 823.95 MHz)_Low

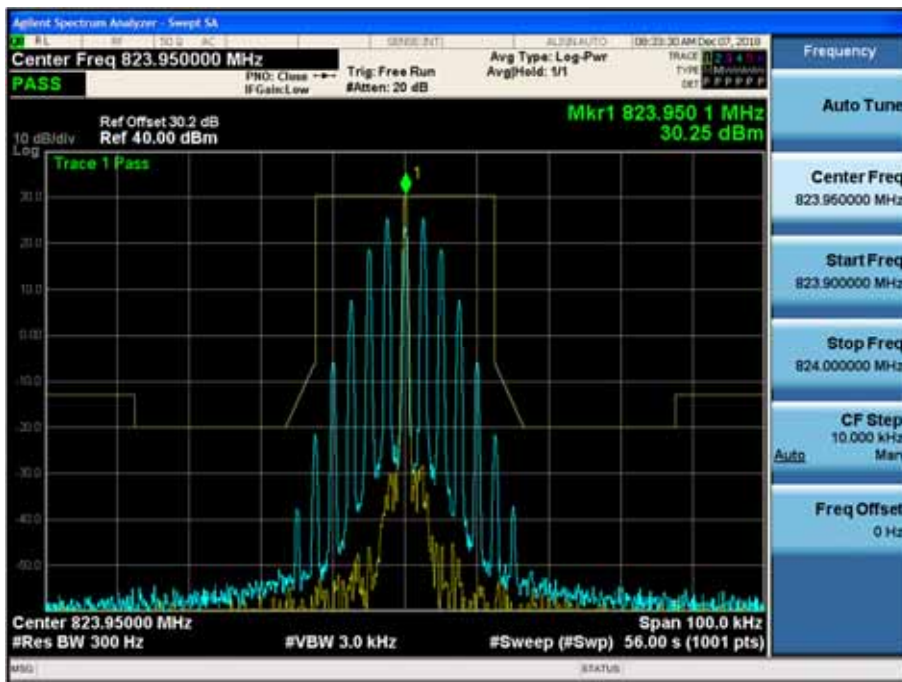

(16K0F3E _ 860.05 MHz)_Low

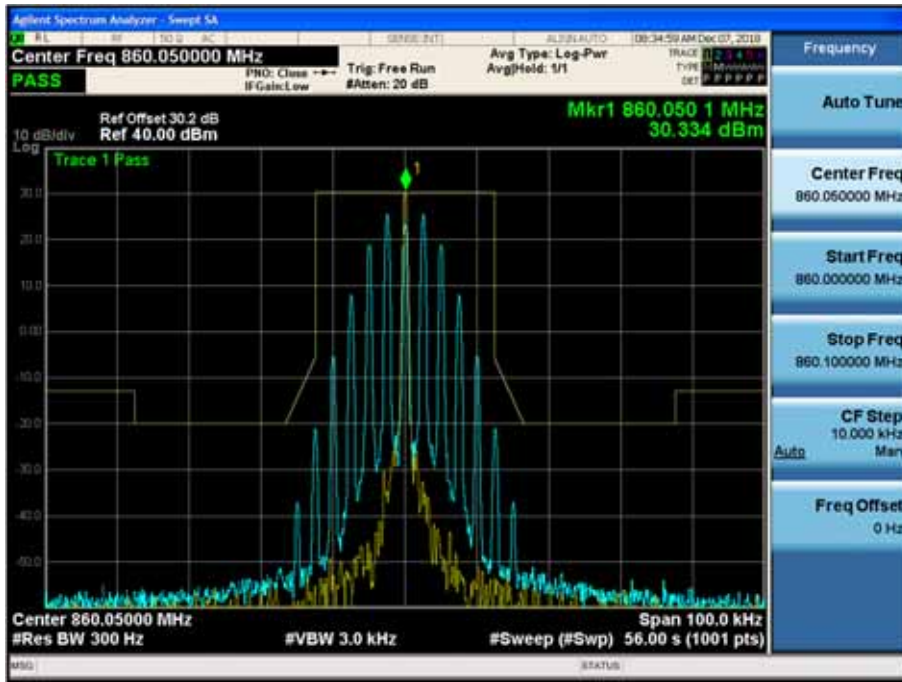

(16K0F3E _ 868.95 MHz)_Low

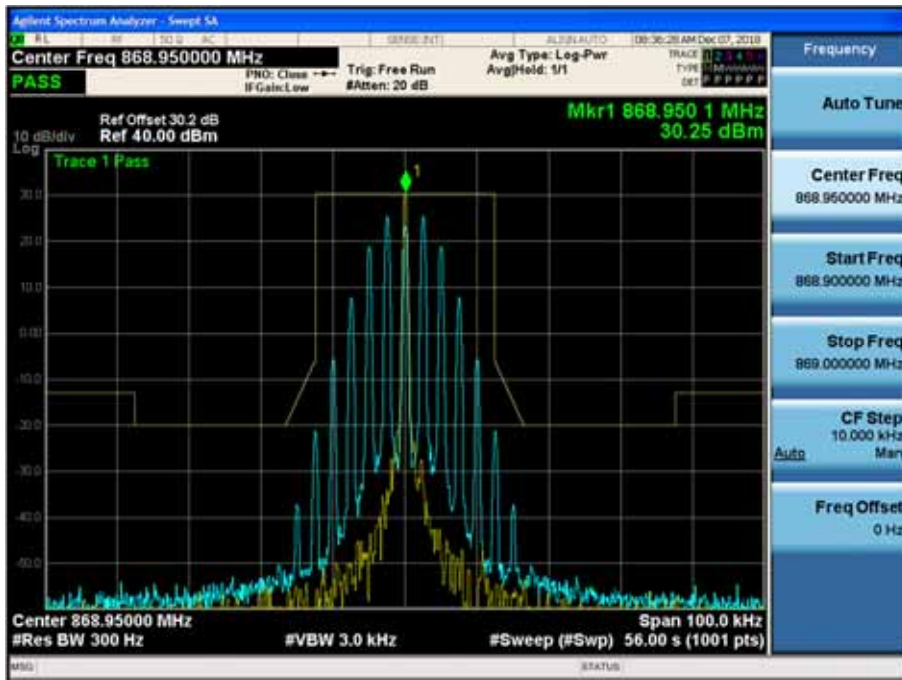

(8K30F1E, 8K30F1D, 8K30F7W _ 815.05 MHz)_High

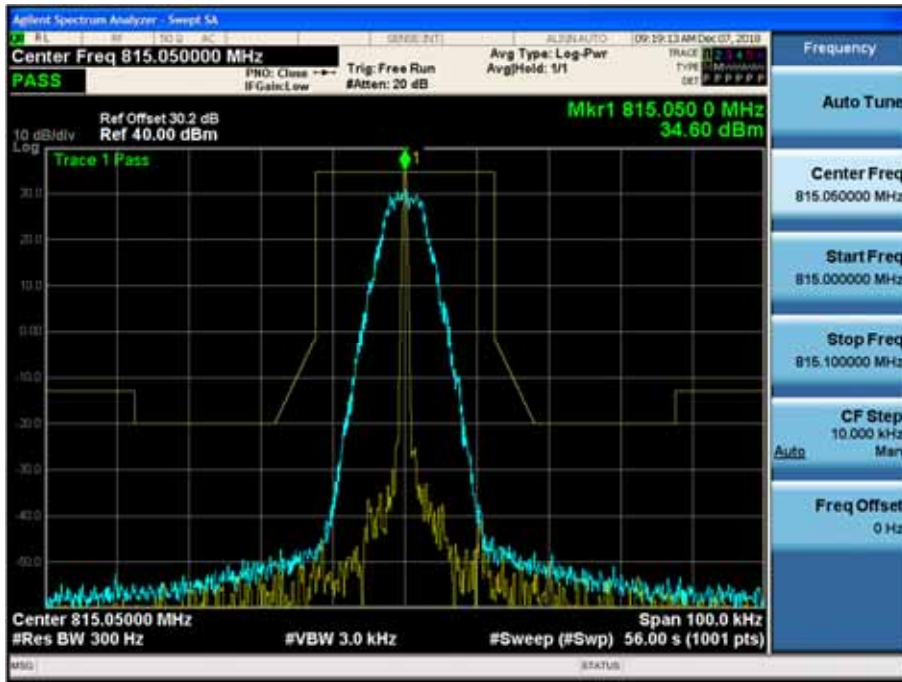

(8K30F1E, 8K30F1D, 8K30F7W _ 823.95 MHz)_High

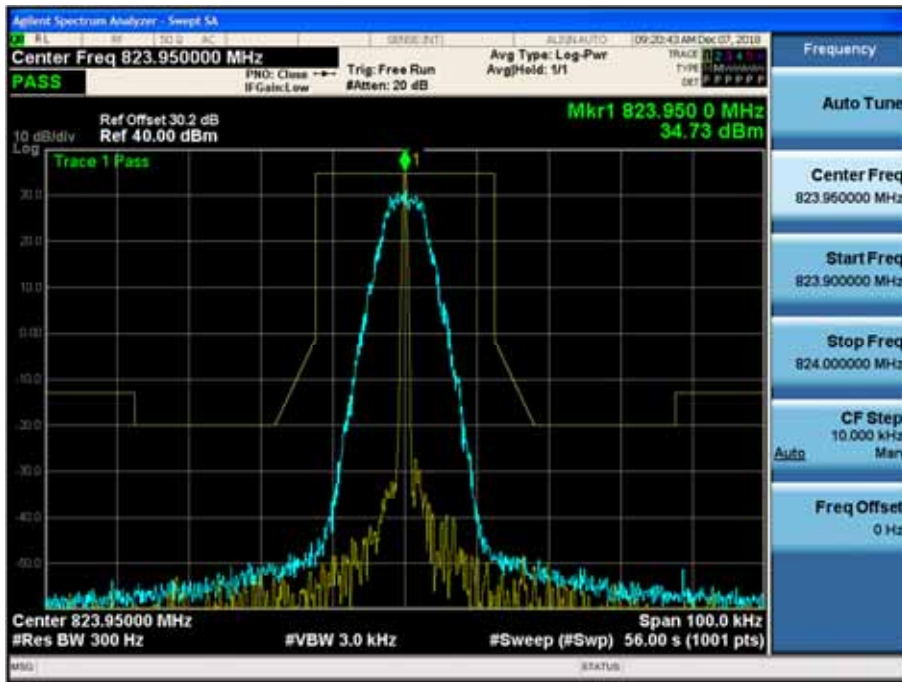

(8K30F1E, 8K30F1D, 8K30F7W _ 860.05 MHz)_High

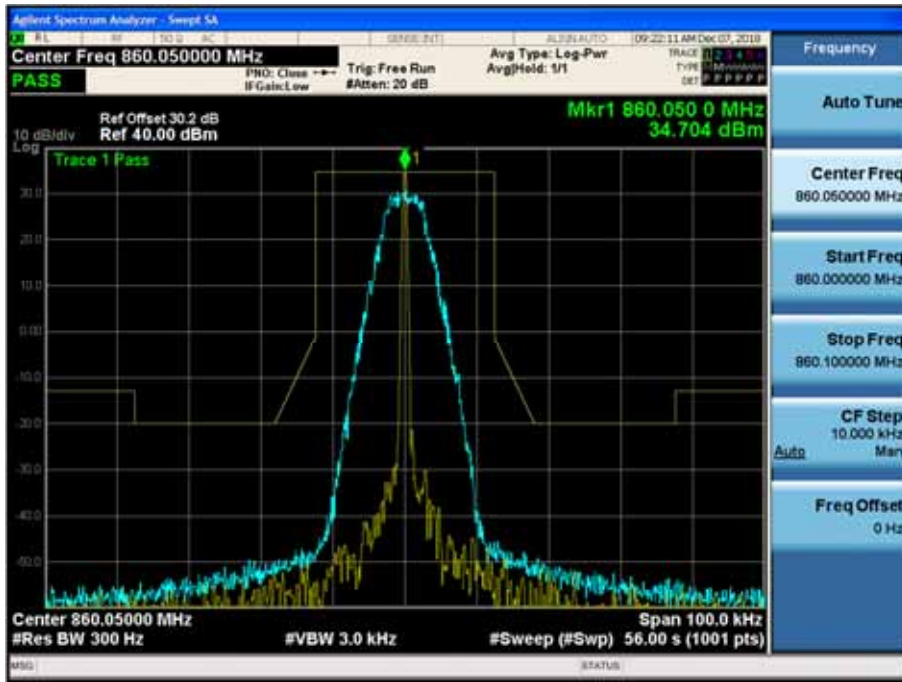

(8K30F1E, 8K30F1D, 8K30F7W _ 868.95 MHz)_ High

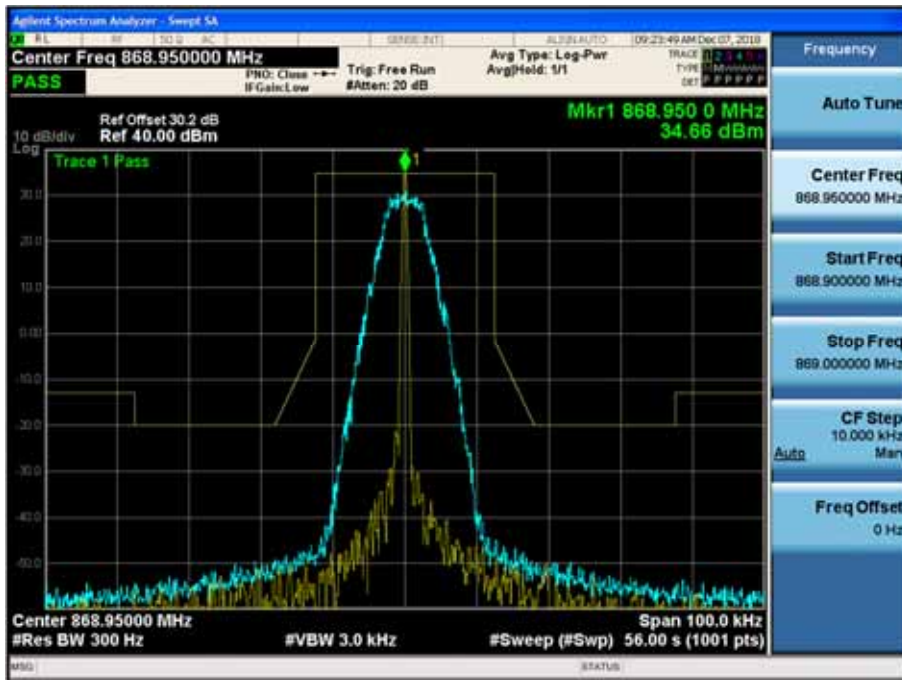

(8K30F1E, 8K30F1D, 8K30F7W _ 815.05 MHz)_ Low

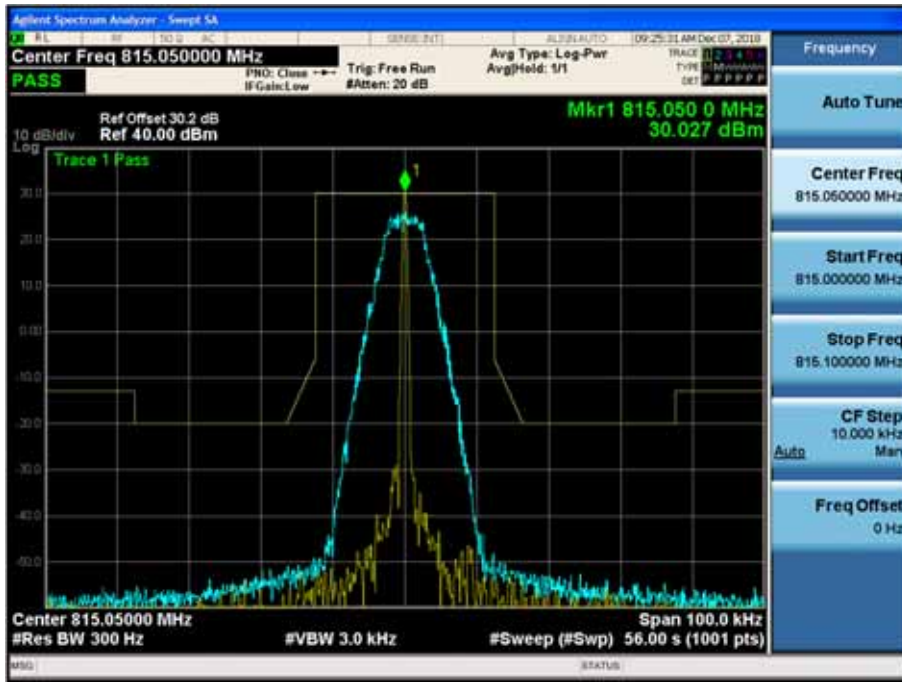

(8K30F1E, 8K30F1D, 8K30F7W _ 823.95 MHz)_ Low

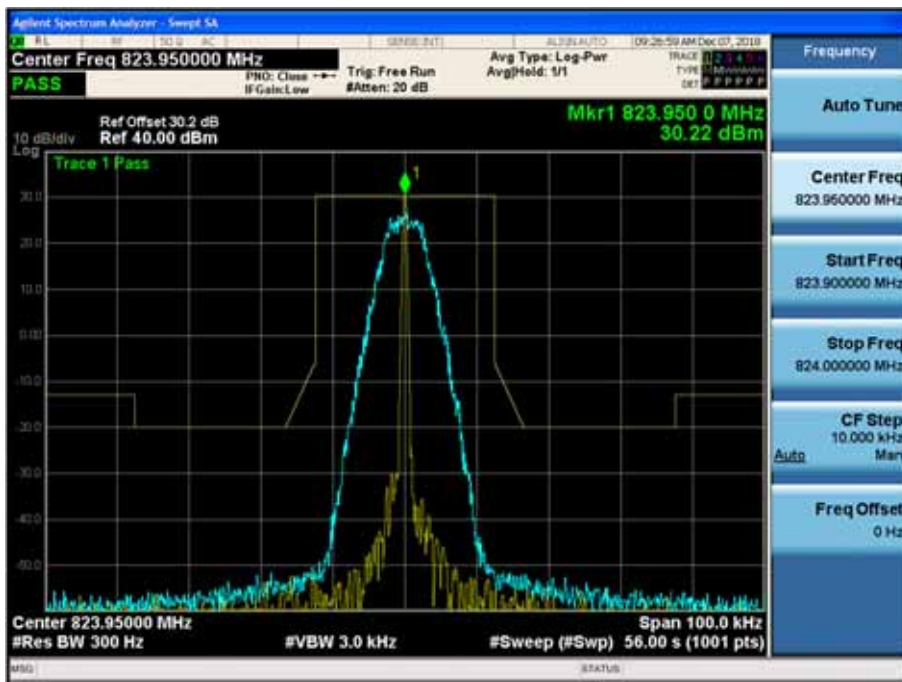

(8K30F1E, 8K30F1D, 8K30F7W _ 860.05 MHz)_ Low

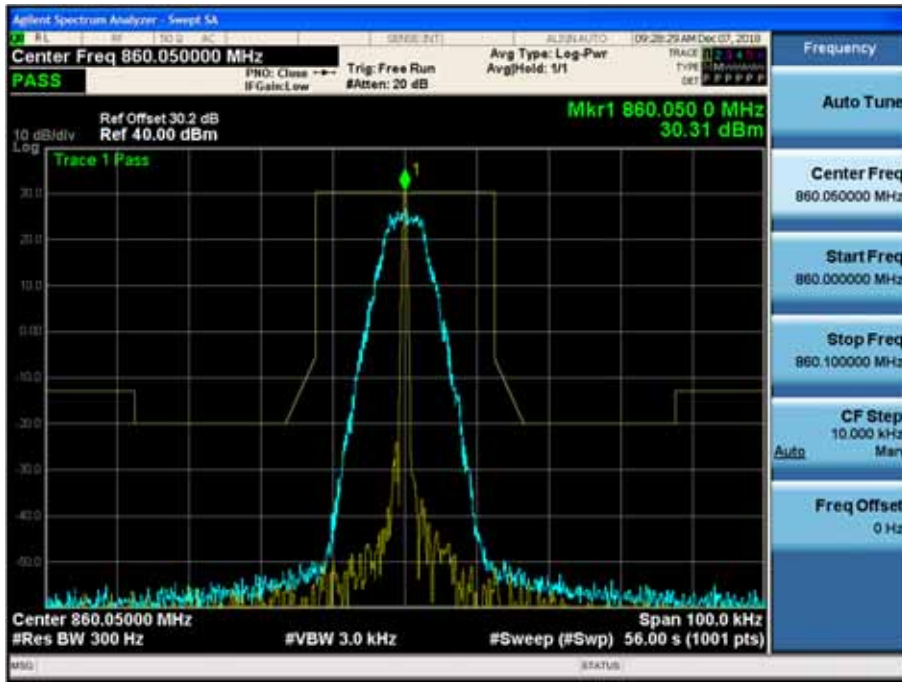

(8K30F1E, 8K30F1D, 8K30F7W _ 868.95 MHz)_ Low

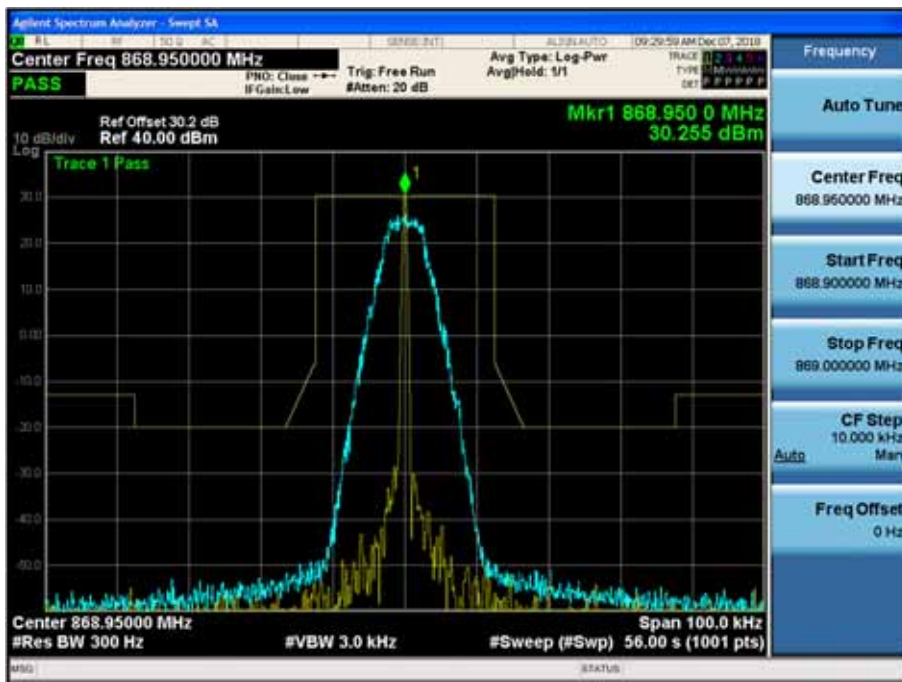

(7K60FXE, 7K60FXD _ 815.05 MHz)_High

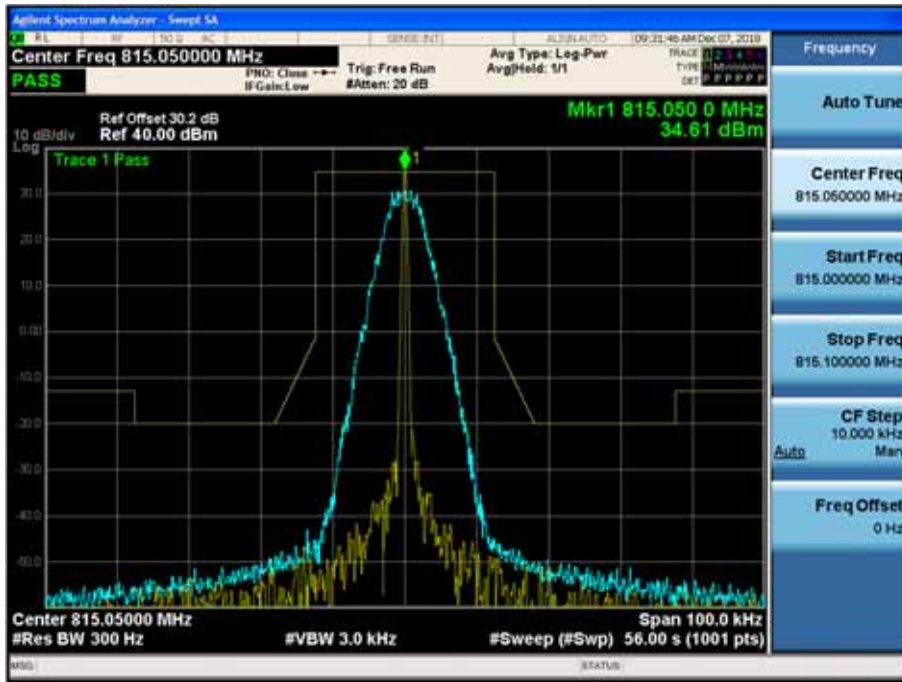

(7K60FXE, 7K60FXD _ 823.95 MHz)_High

