

(450.05 MHz)_High

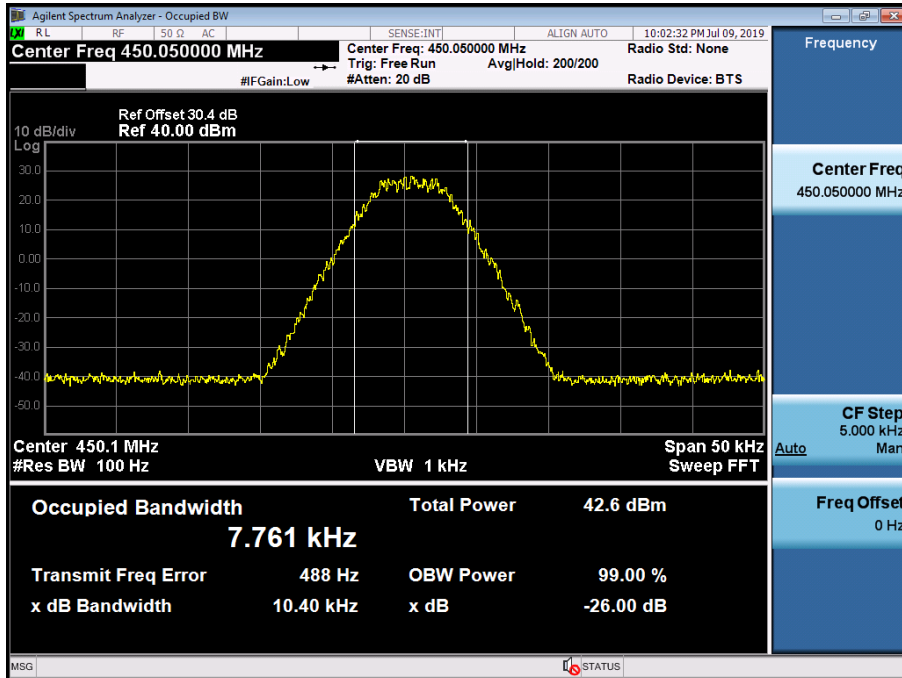

(469.95 MHz)_High

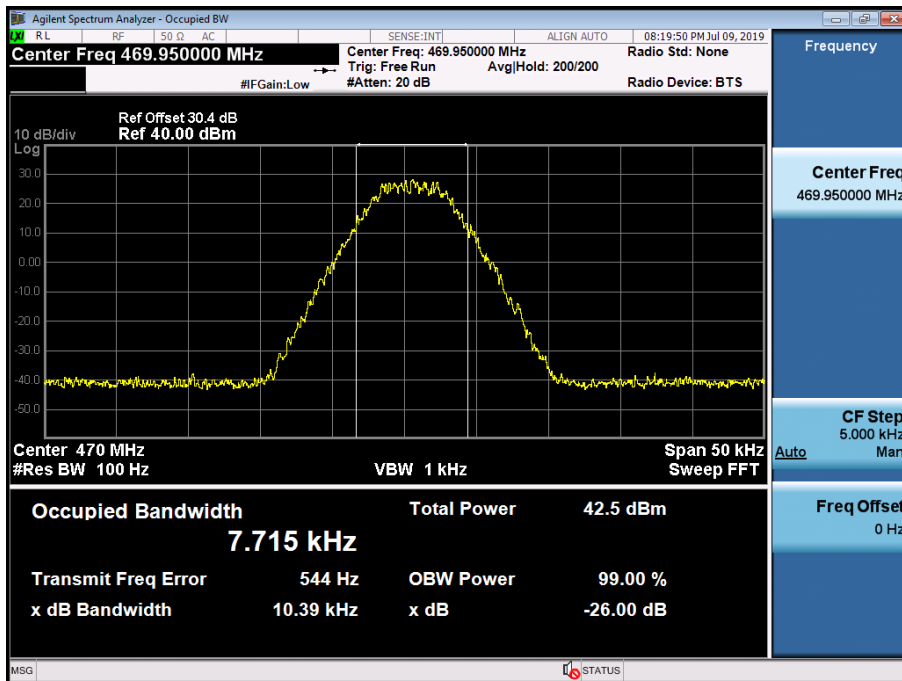

(406.15 MHz)_Low

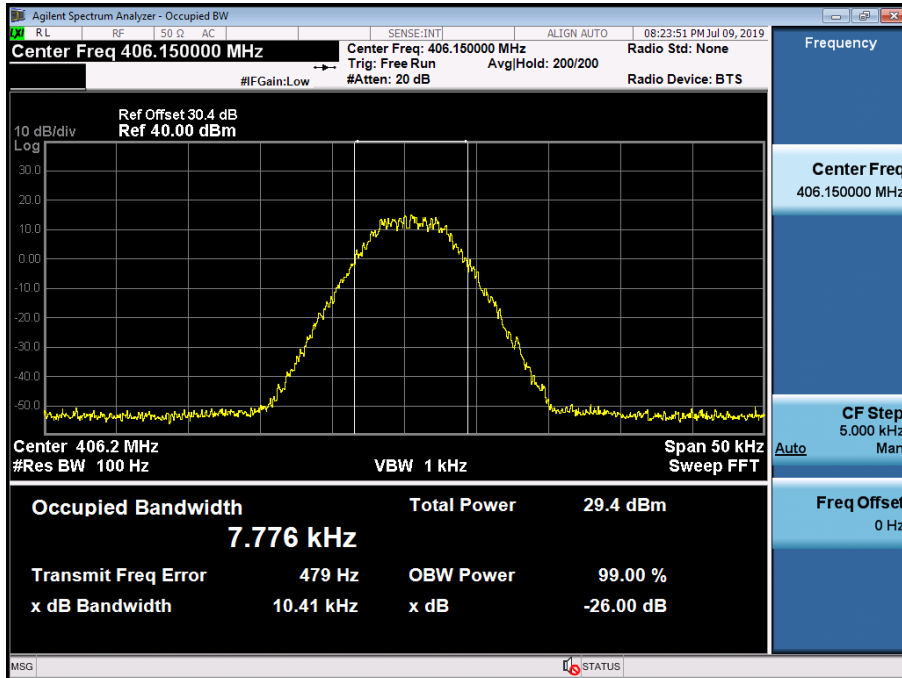

(429.95 MHz)_Low

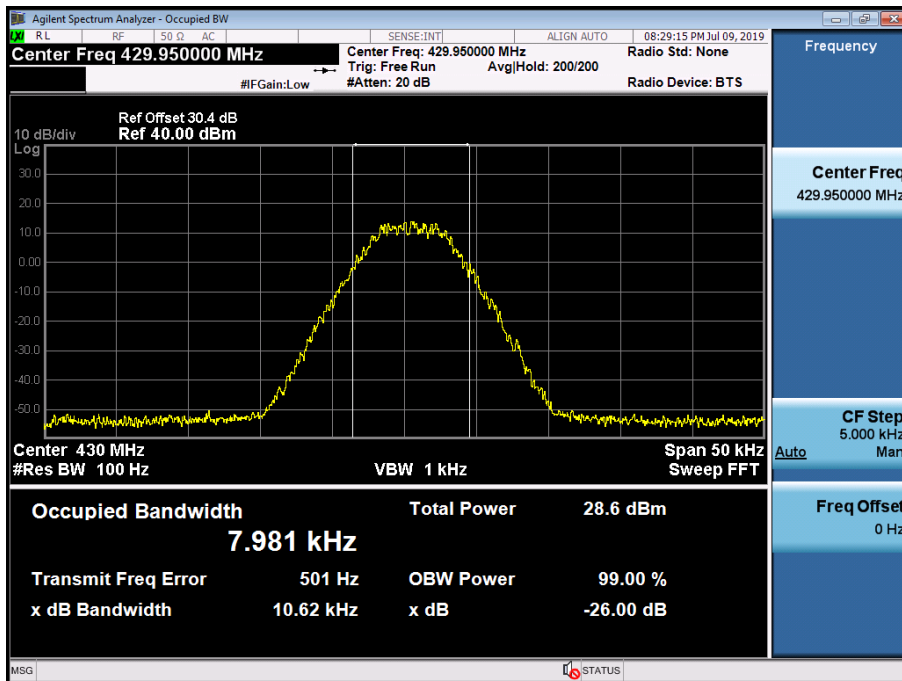

(450.05 MHz)_Low

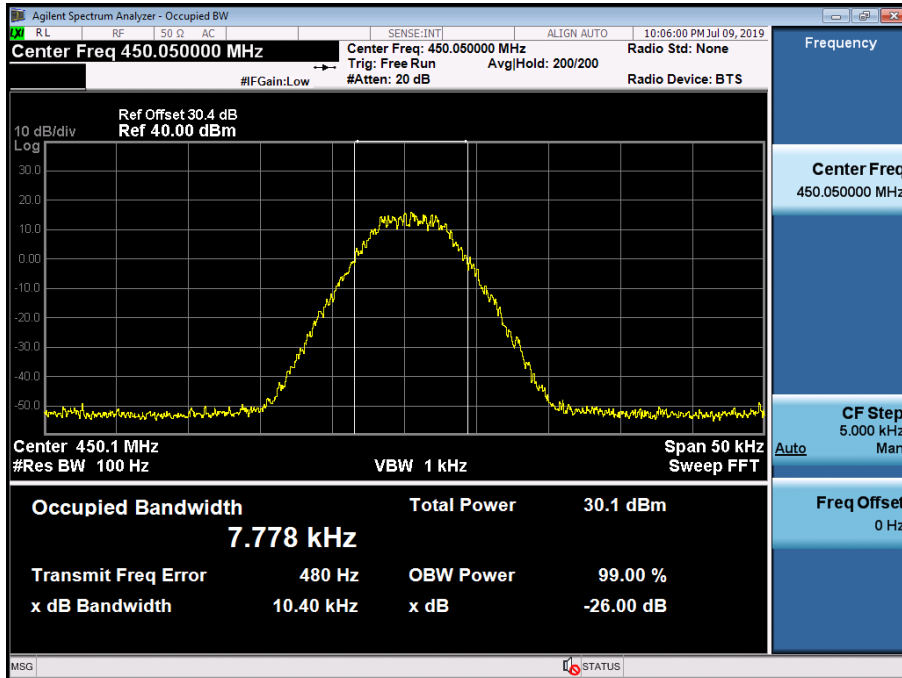

(469.95 MHz)_Low

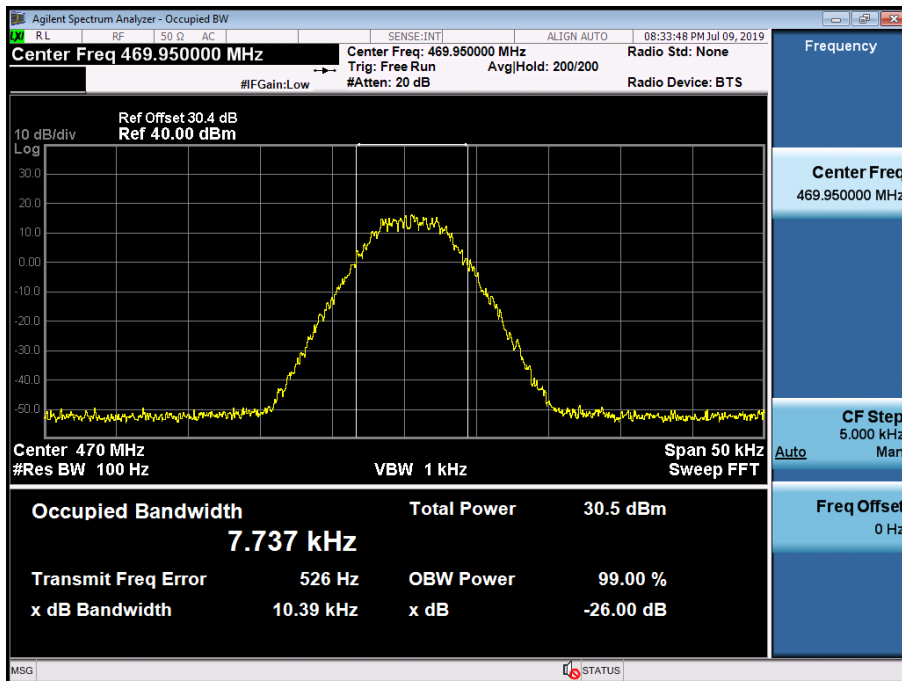

7K60FXD, 7K60FXE_FCC/IC

(406.15 MHz)_High

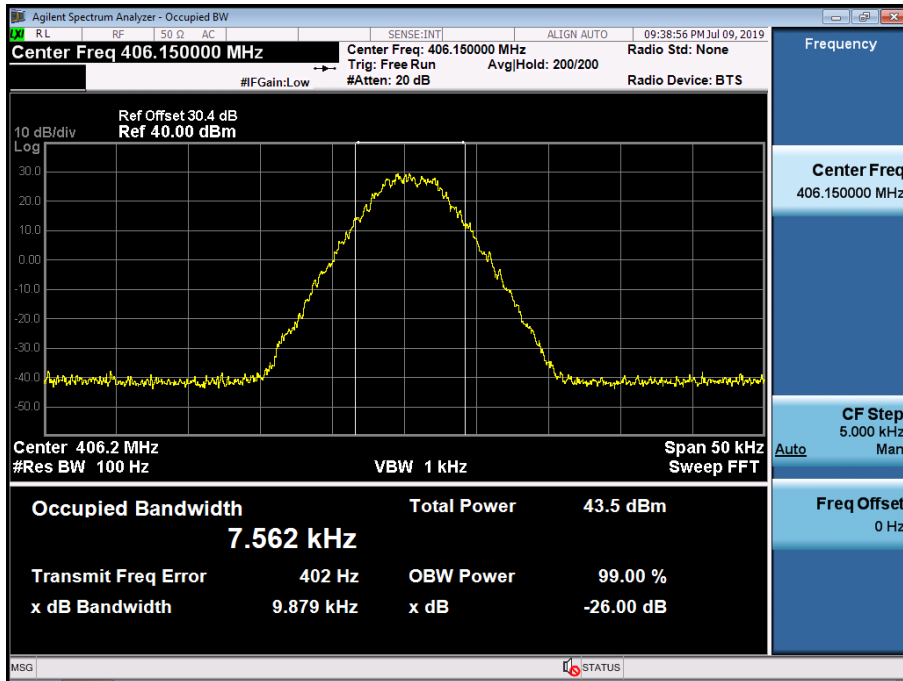

(429.95 MHz)_High

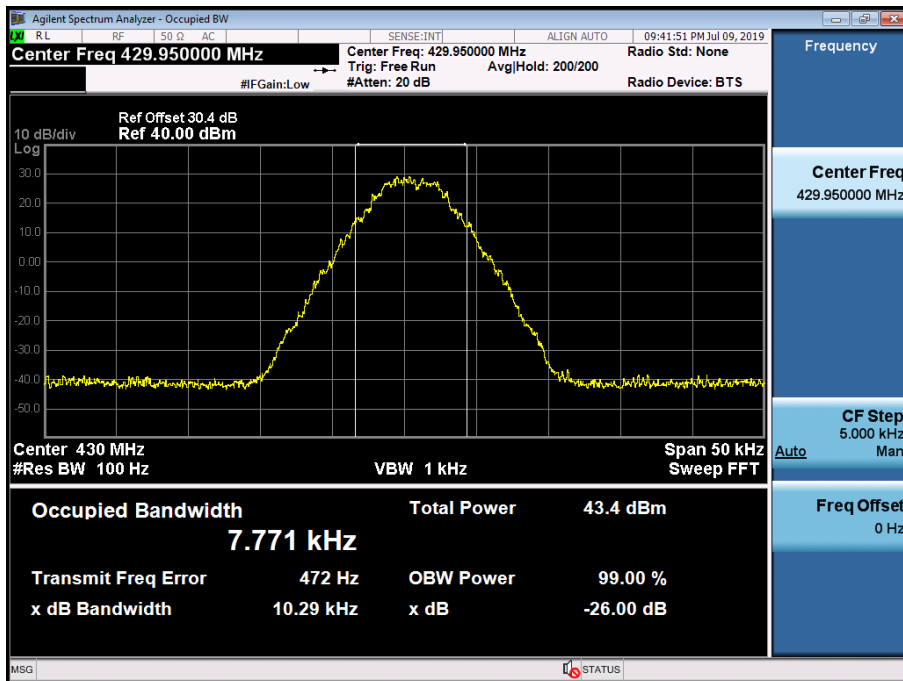

(450.05 MHz)_High

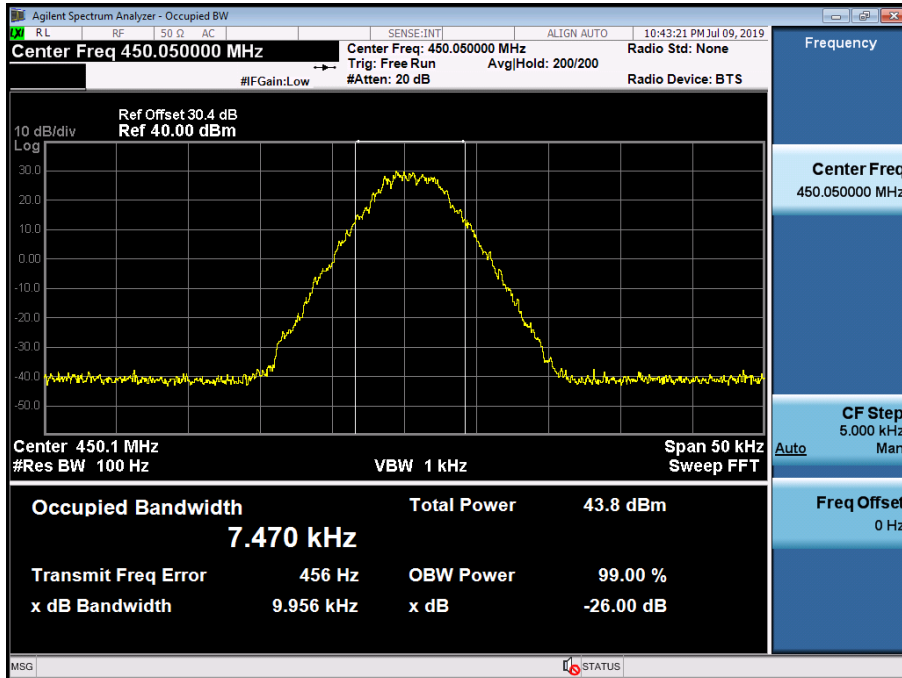

(469.95 MHz)_High

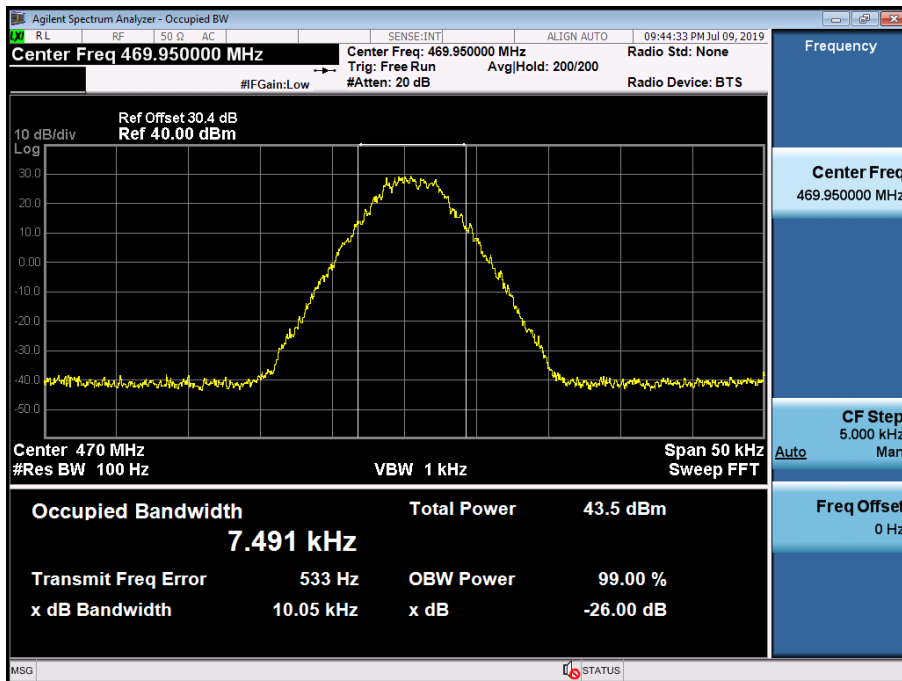

(406.15 MHz)_Low

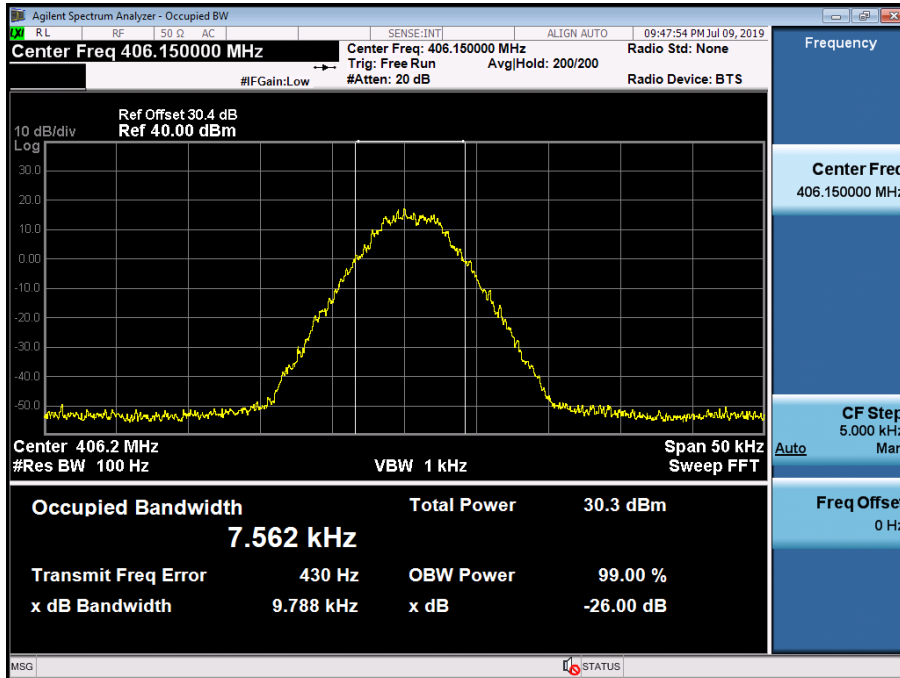

(429.95 MHz)_Low

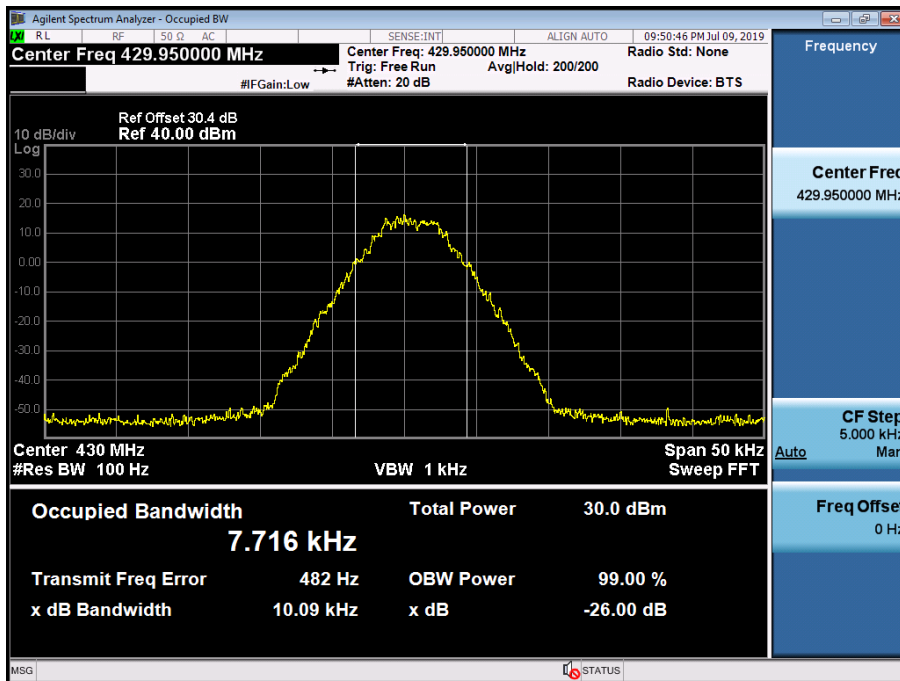

(450.05 MHz)_Low

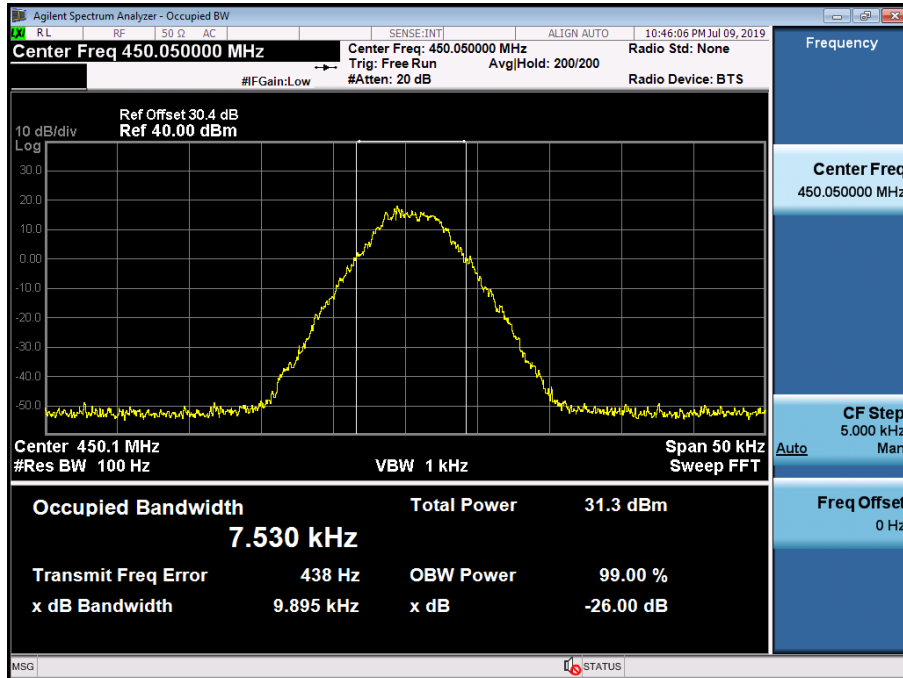

(469.95 MHz)_Low

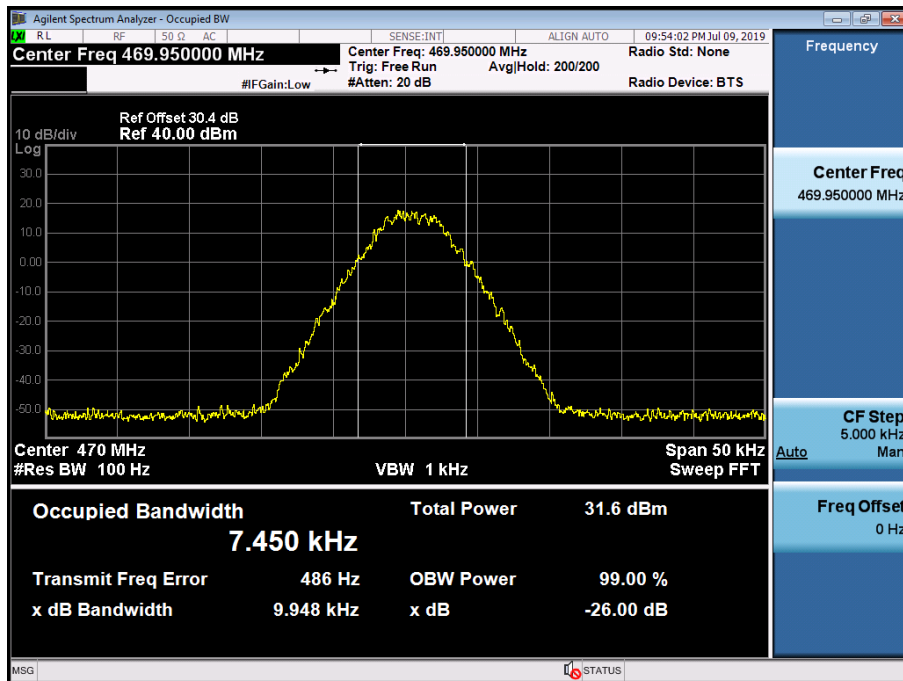

4K00F1E, 4K00F1D, 4K00F7W_FCC/IC

(406.15 MHz)_High

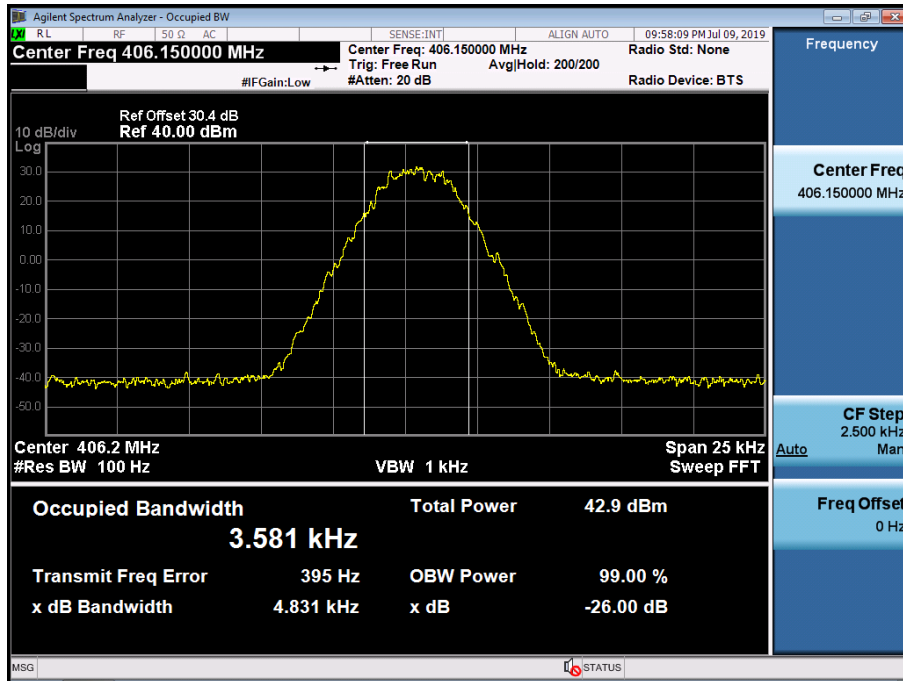

(429.95 MHz)_High

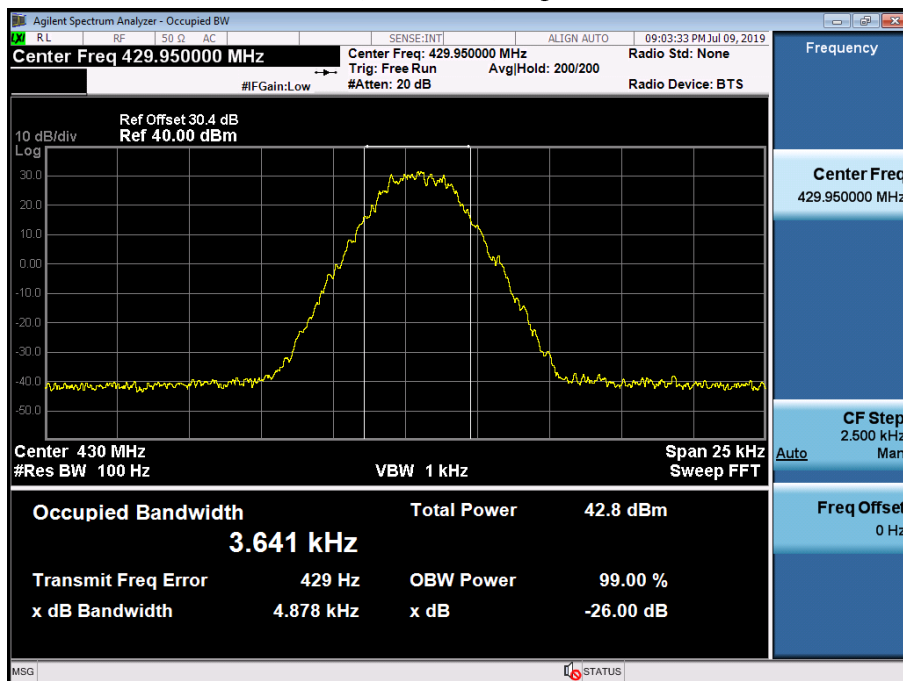

(450.05 MHz)_High

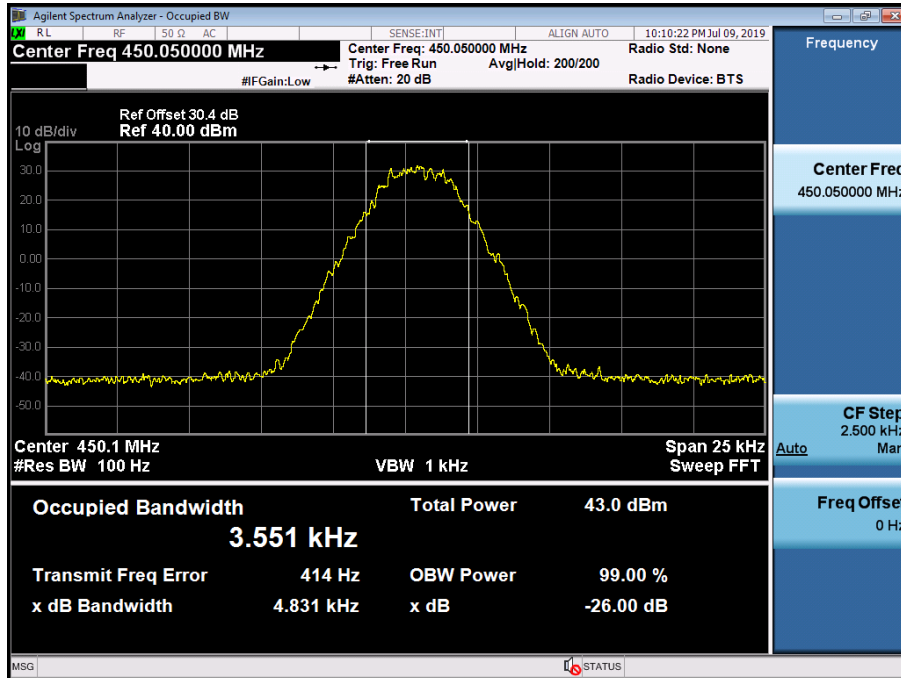

(469.95 MHz)_High

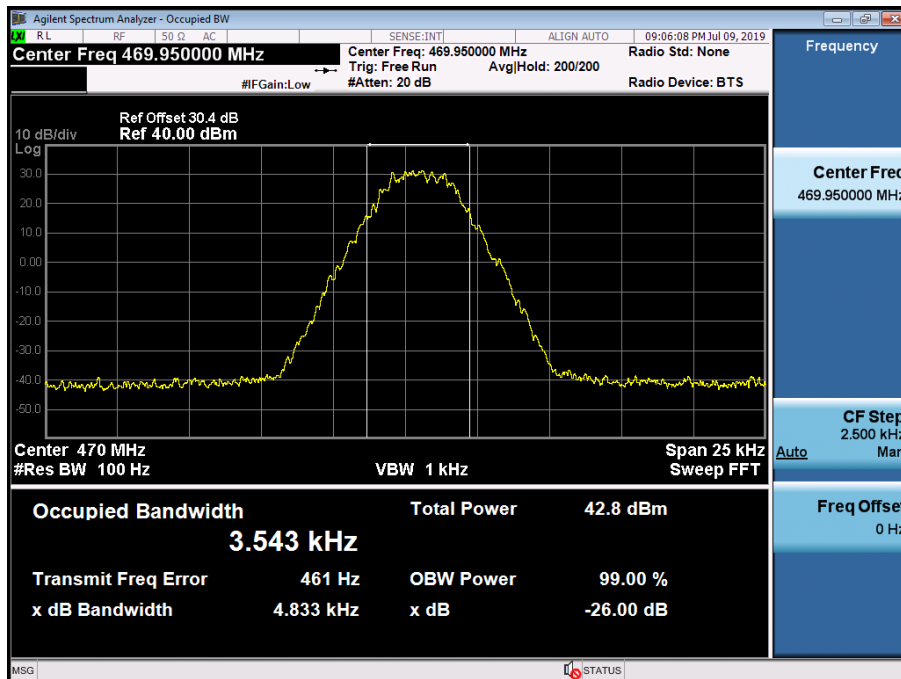

(406.15 MHz)_Low

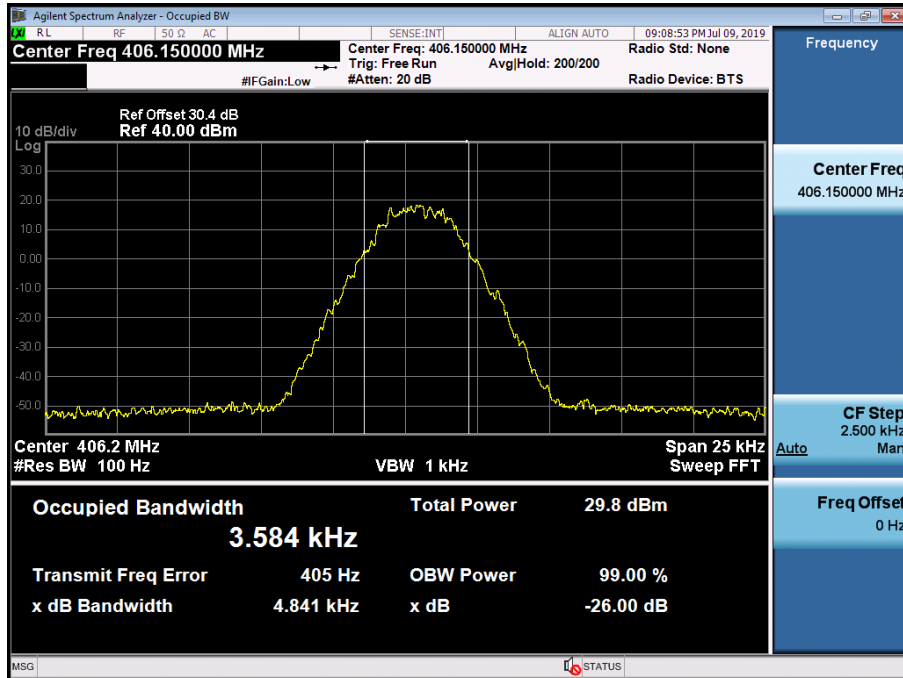

(429.95 MHz)_Low

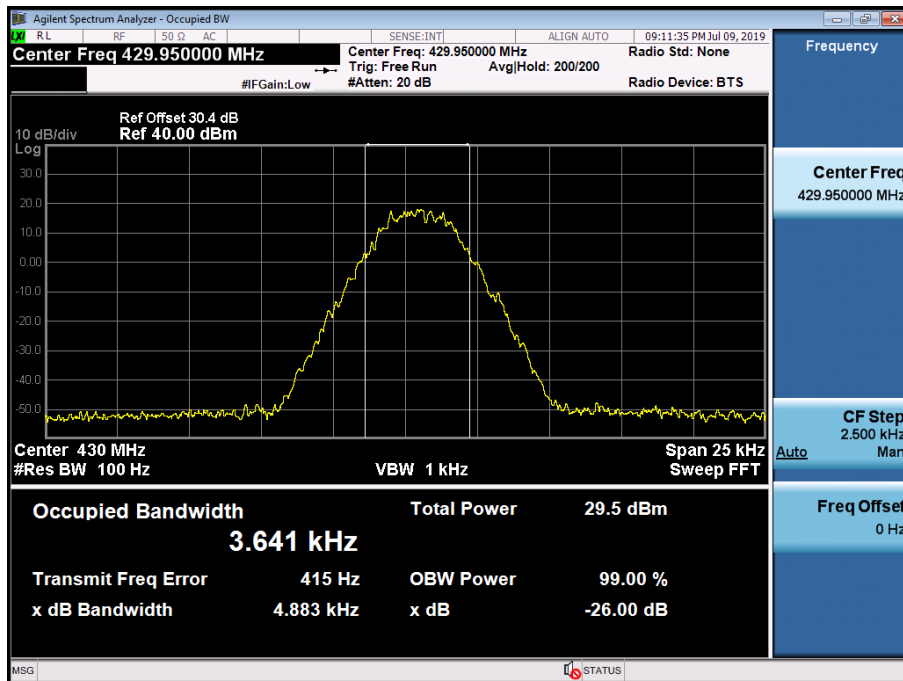

(450.05 MHz)_Low

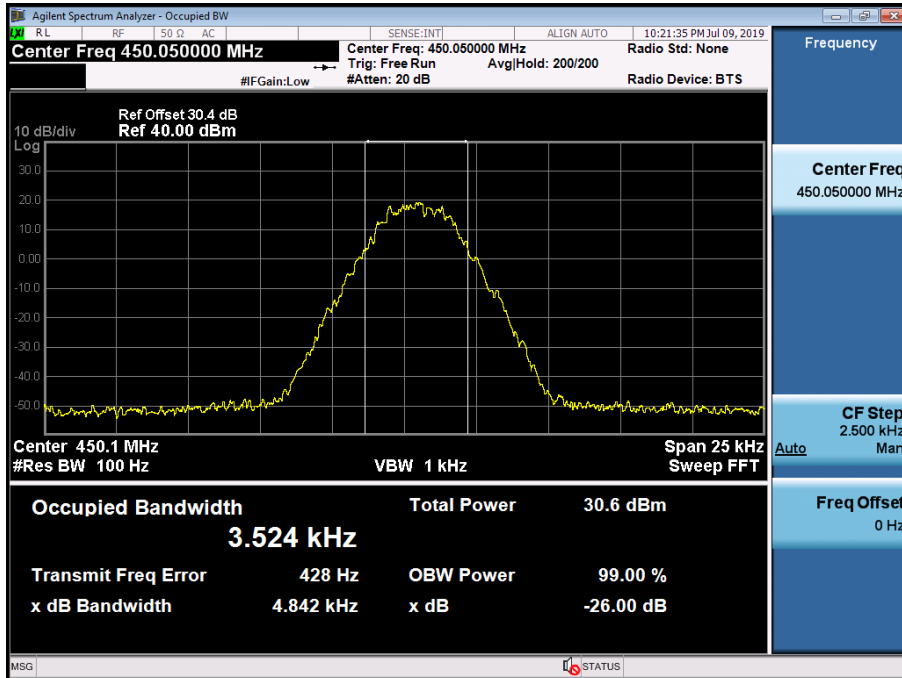

(469.95 MHz)_Low

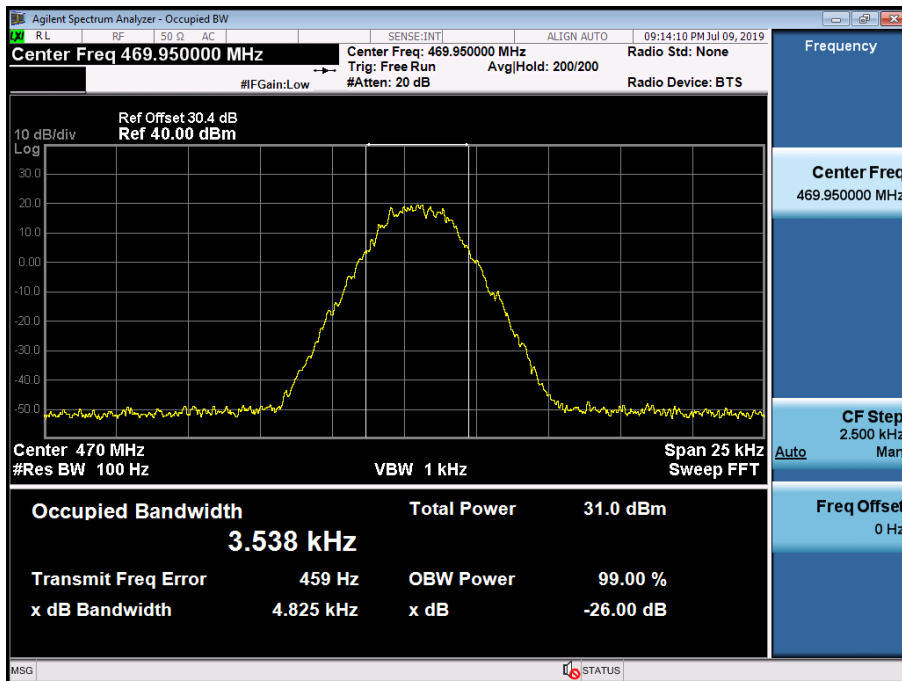

4K00F2D_FCC/IC

(406.15 MHz)_High

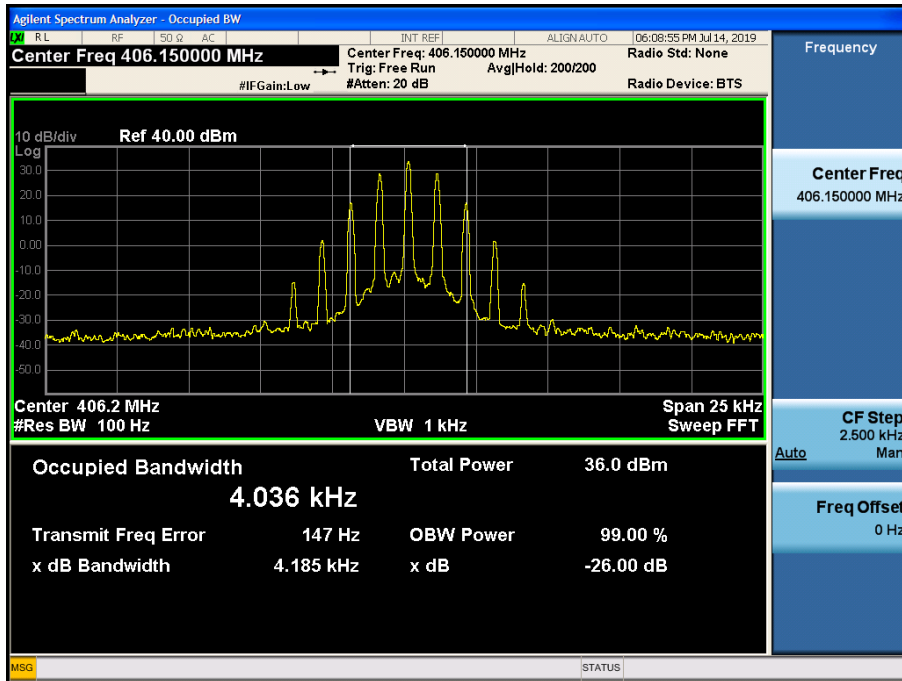

(429.95 MHz)_High

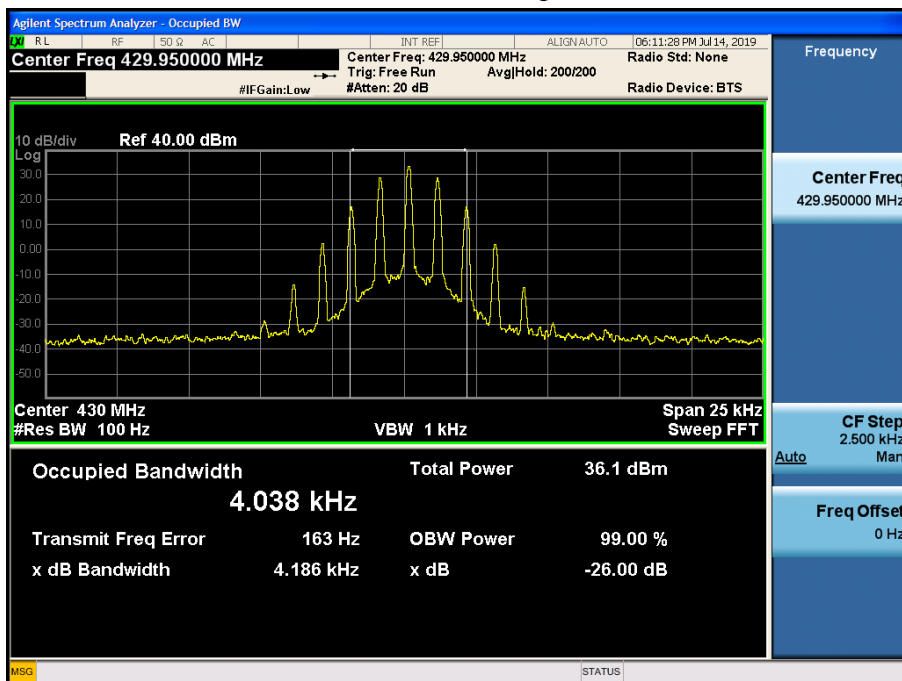

(450.05 MHz)_High

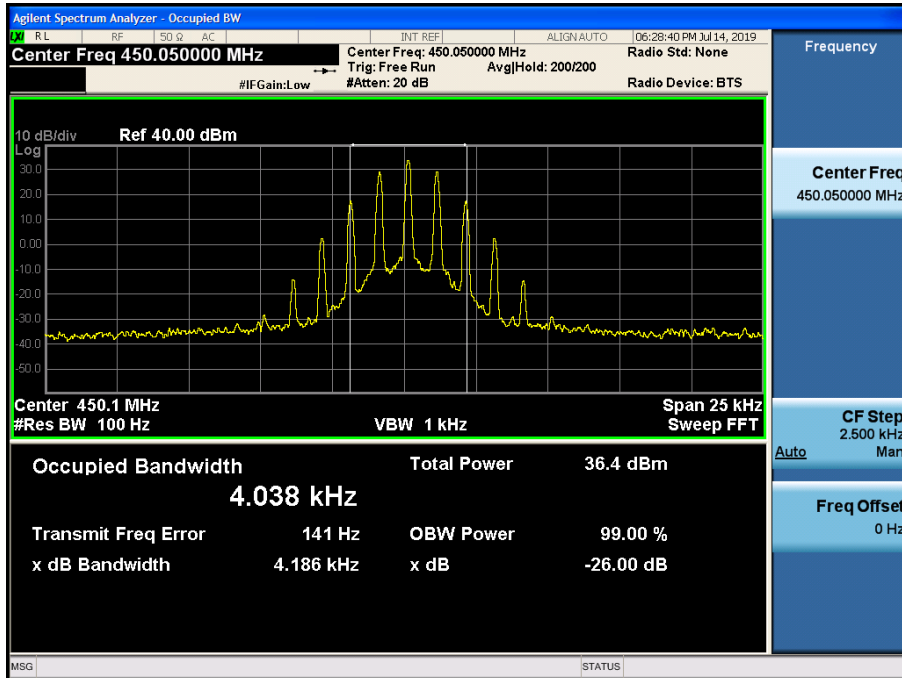

(469.95 MHz)_High

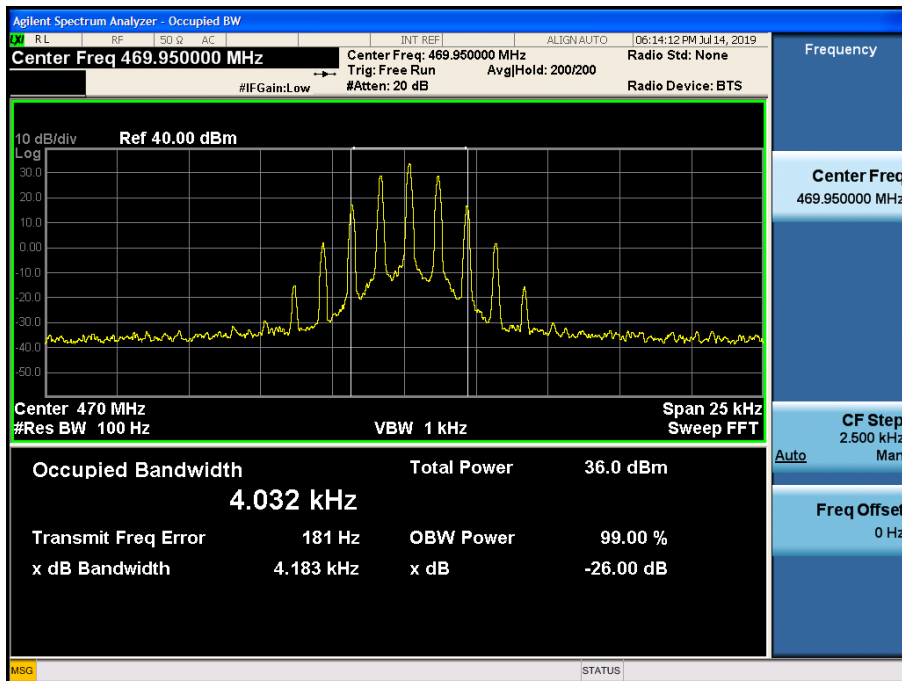

(406.15 MHz)_Low

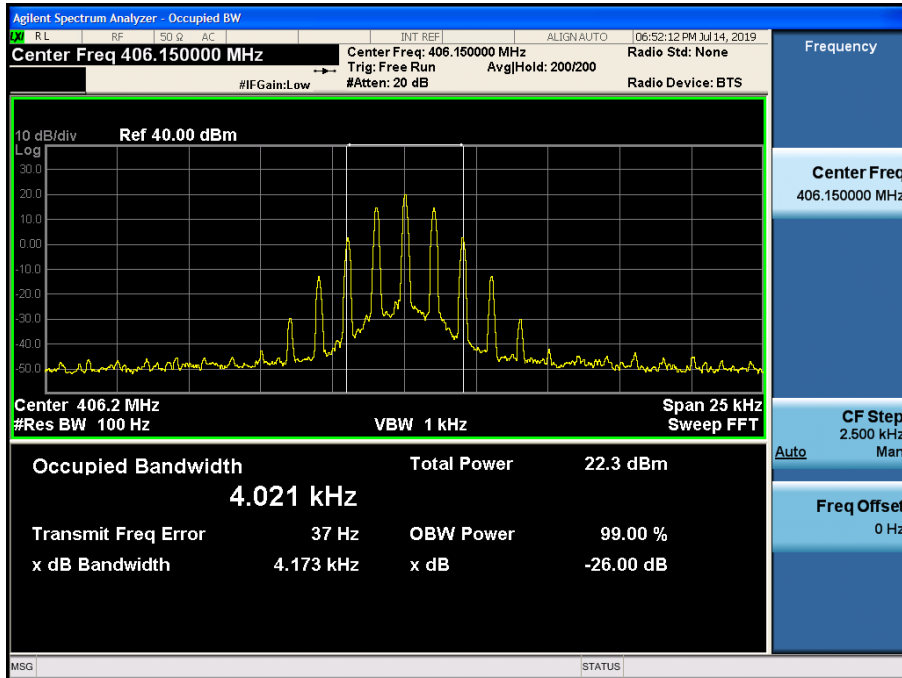

(429.95 MHz)_Low

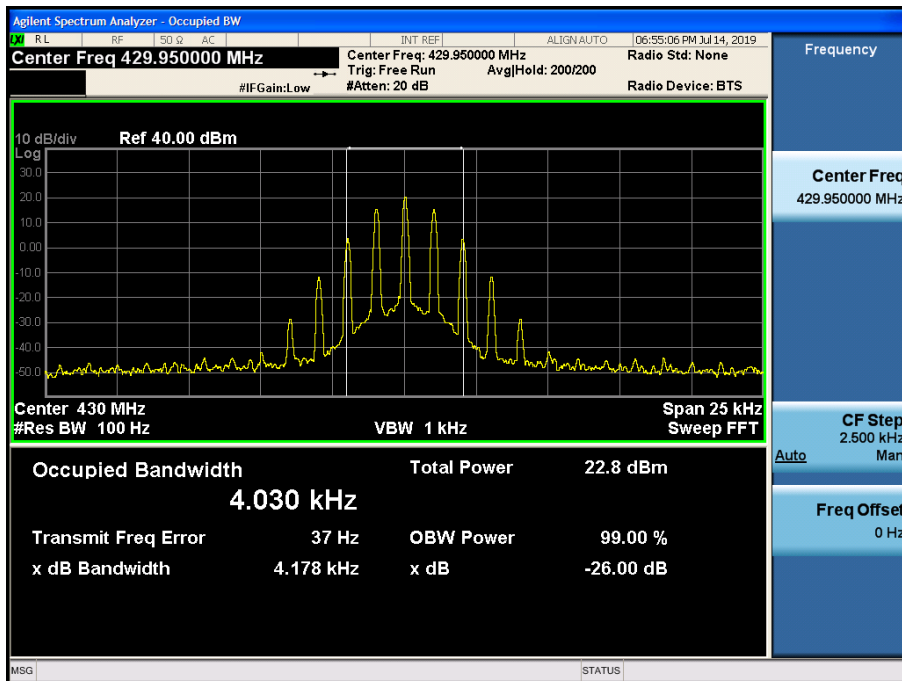

(450.05 MHz)_ Low

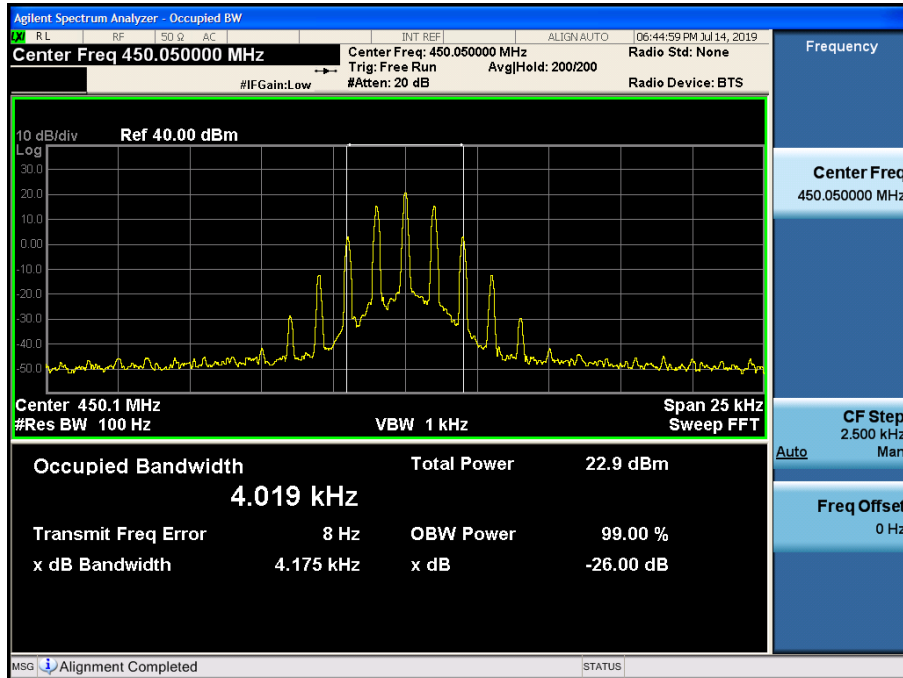

(469.95 MHz)_ Low

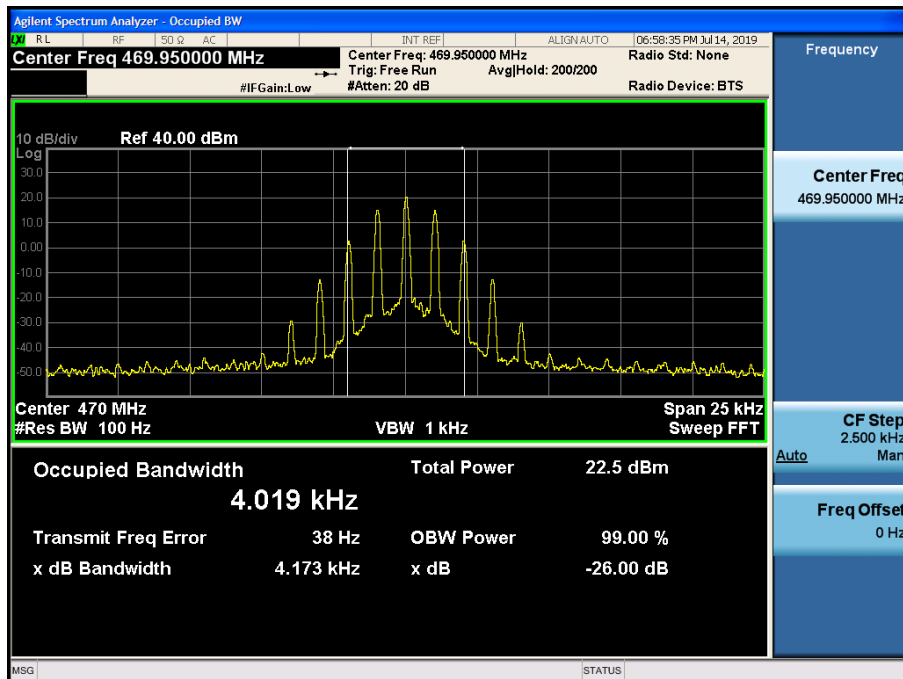

8.4 Modulation Limiting

▣ Definition

Modulation limiting is the transmitter circuit's ability to limit the transmitter from producing deviations in excess of a rated system deviation.

▣ TEST CONFIGURATION

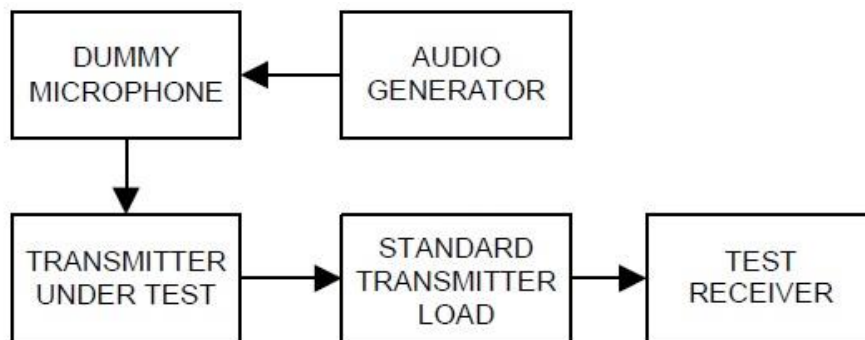

▣ TEST PROCEDURE

According to 2.2.3 in TIA-603-E Standard.

- a) Connect the equipment as illustrated.
- b) Adjust the transmitter per the manufacturer's procedure for full rated system deviation.
- c) Set the test receiver to measure peak positive deviation.
Set the audio bandwidth for ≤ 0.25 Hz to $\geq 15,000$ Hz.
Turn the de-emphasis function off.
- d) Apply a 1000 Hz modulating signal to the transmitter from the audio frequency generator, and adjust the level obtain 60% of full rated system deviation.
- e) Increase the level form the audio frequency generator by 20 dB in one step(rise time between the 10% and 90% points shall be 0.1 second maximum).
- f) Measure both the instantaneous and steady-state deviation at and after the time of increasing the audio input level.
- g) With the level from the audio frequency generator held constant at the level obtained in step e), Slowly vary the audio frequency from 300 Hz to 3000 Hz and observe the steady-state deviation. Record the maximum deviation.
- h) Set the test receiver to measure peak negative deviation and repeat steps d) through g).
- i) The values recorded in steps g) and h) are the modulation limiting.

▣ TEST RESULTS (11K0F3E)

Positive Peaks

HIGH POWER

406.15 MHz

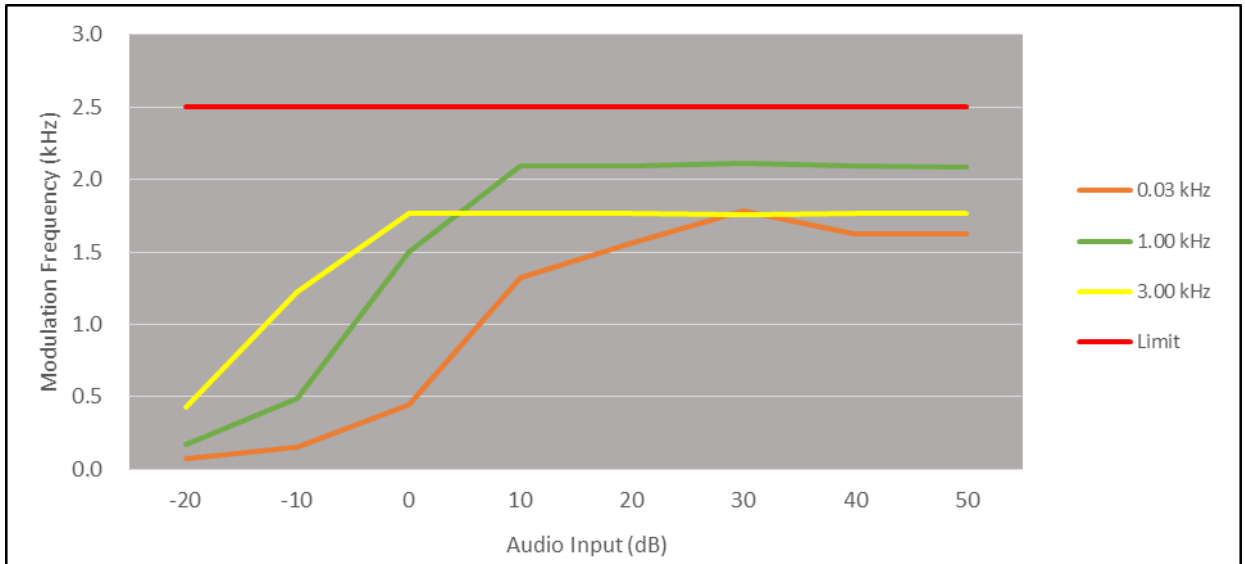

429.95 MHz

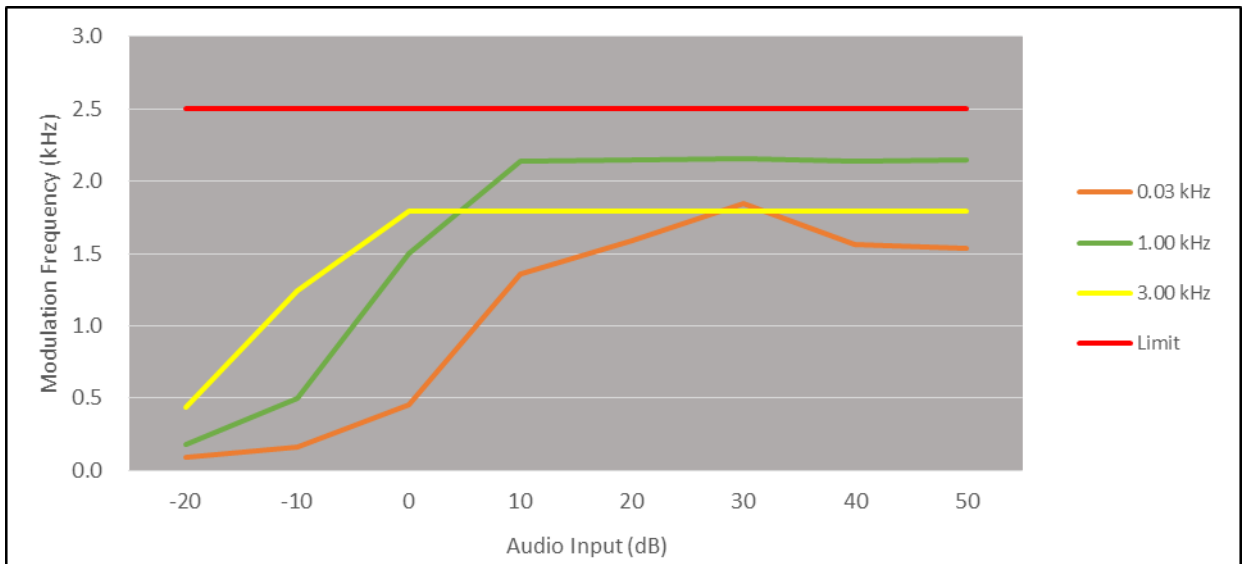

450.05 MHz

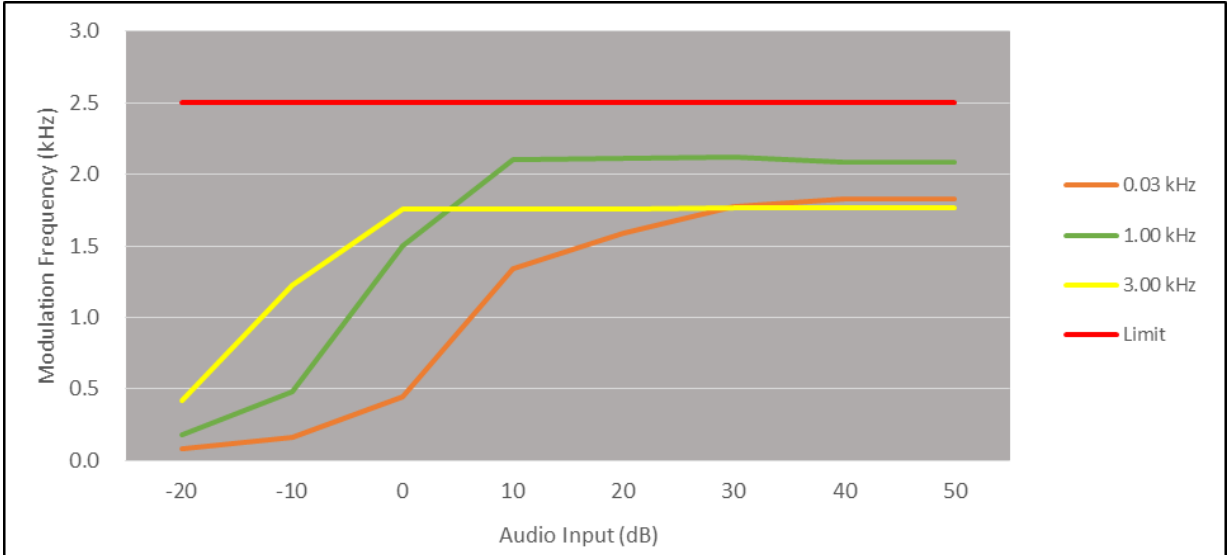

469.95 MHz

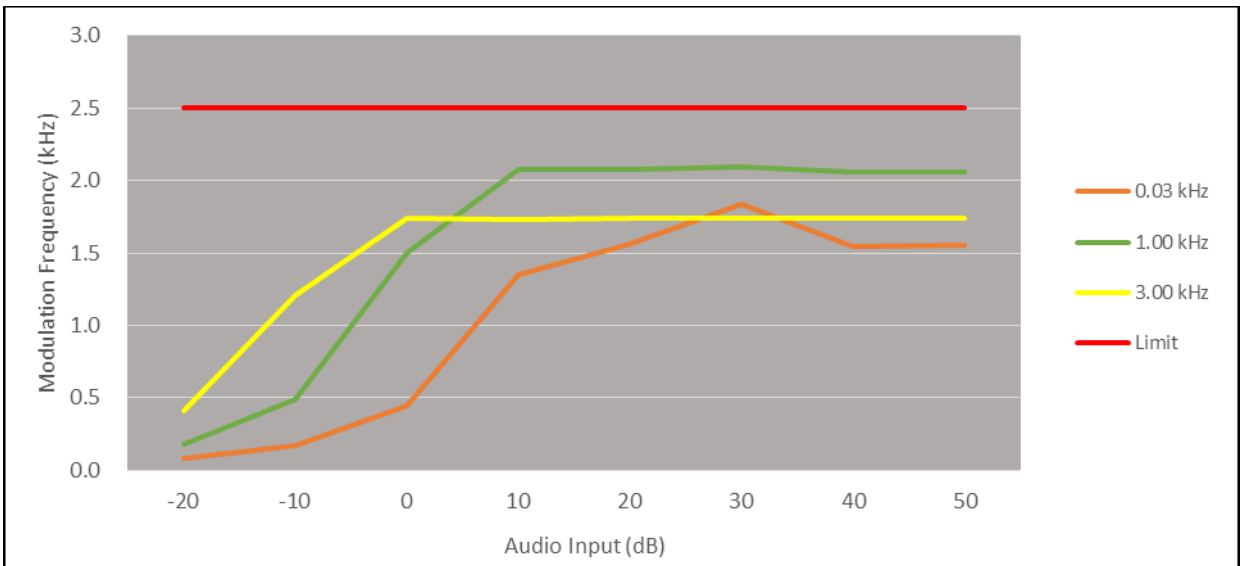

LOW POWER

406.15 MHz

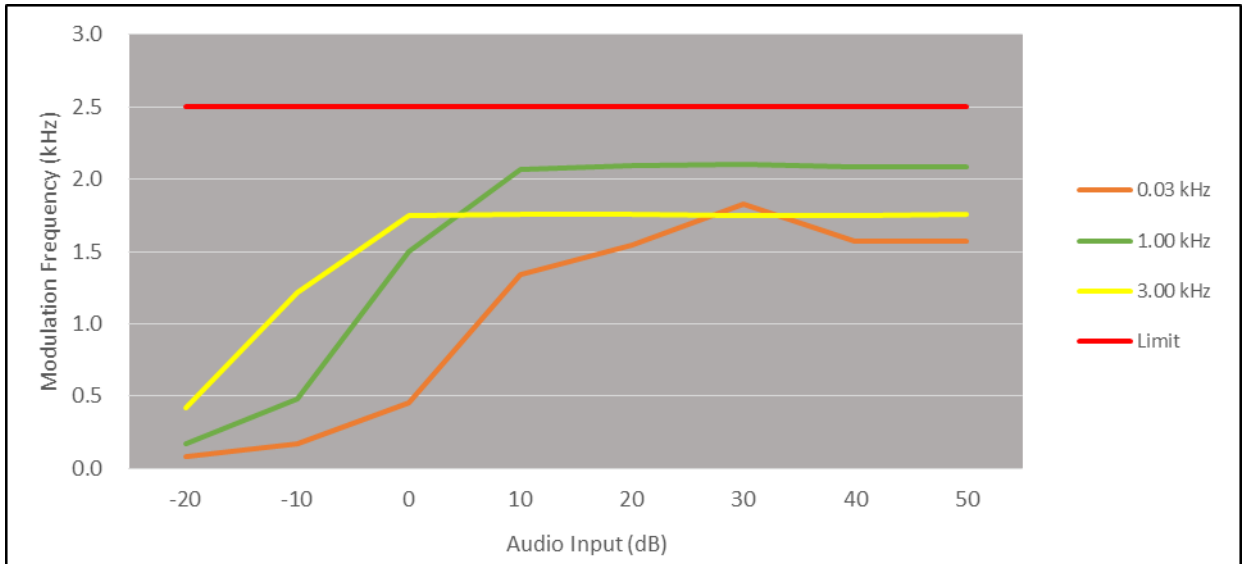

429.95 MHz

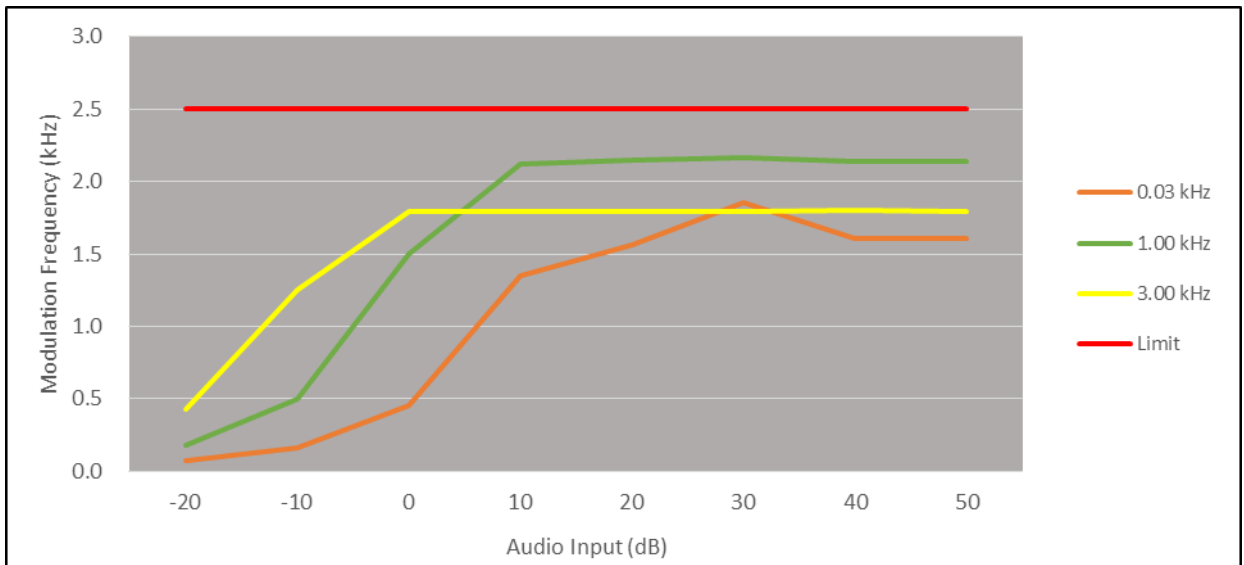

450.05 MHz

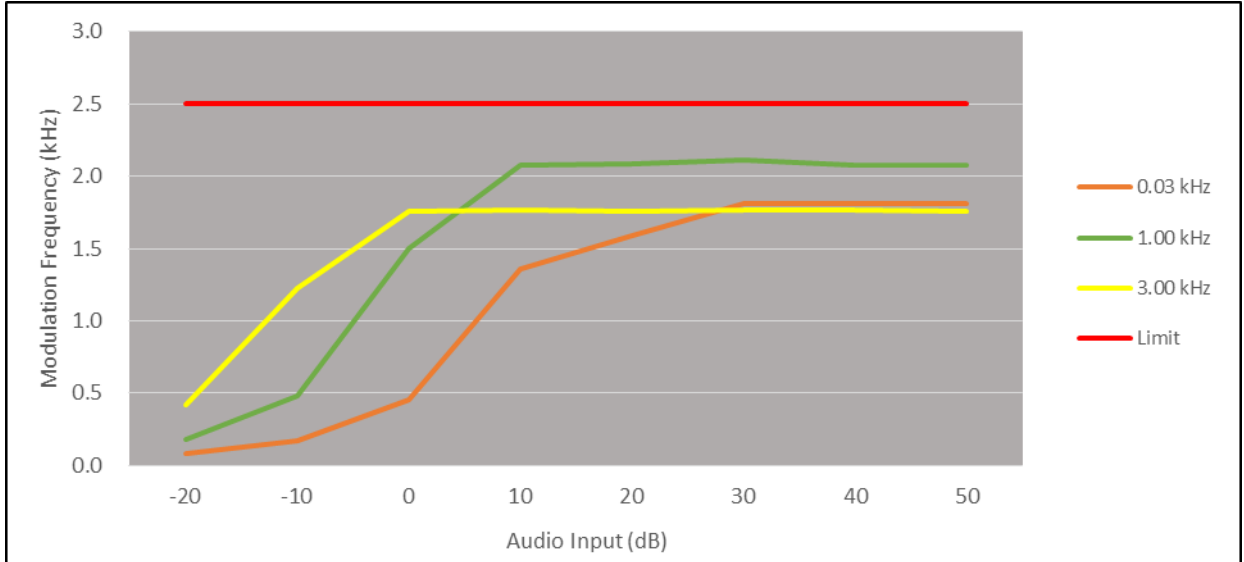

469.95 MHz

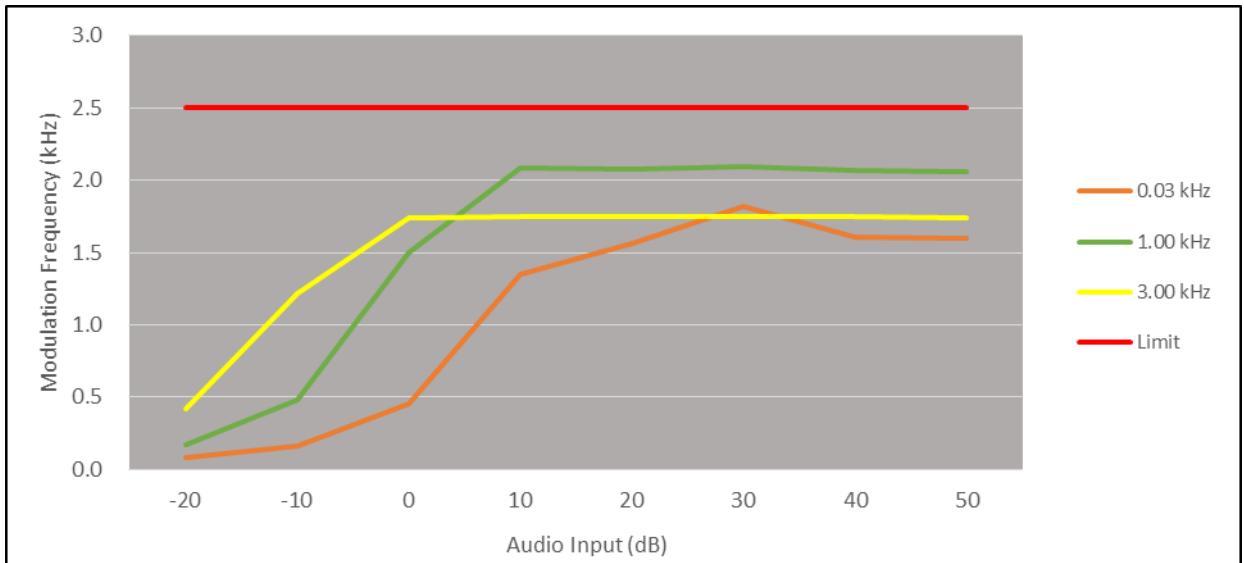

Negative Peaks

HIGH POWER

406.15 MHz

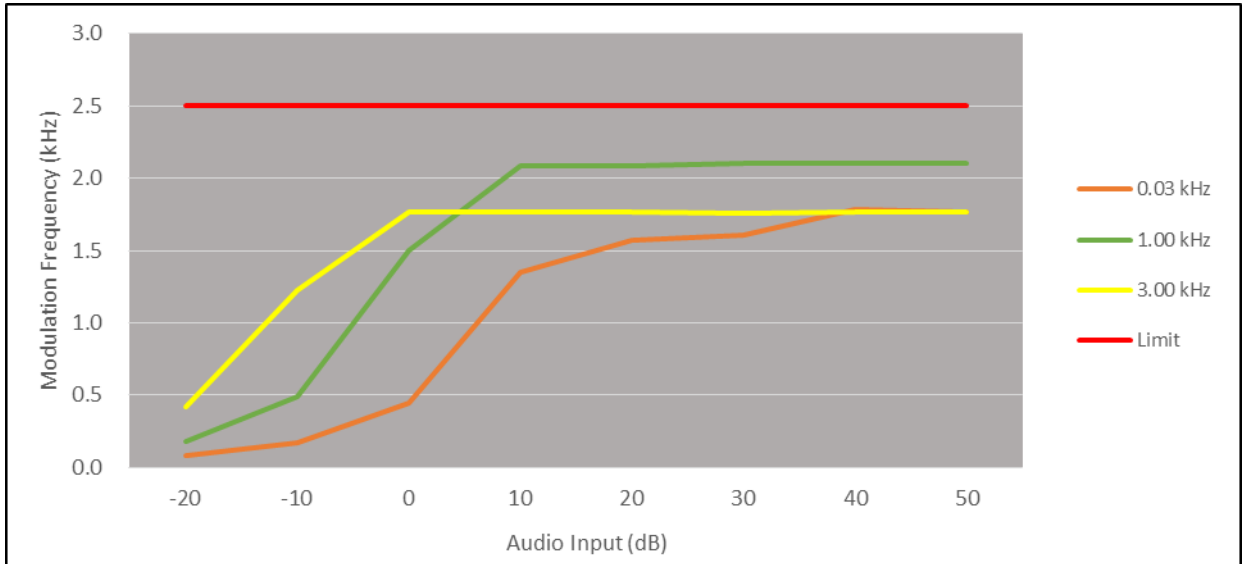

429.95 MHz

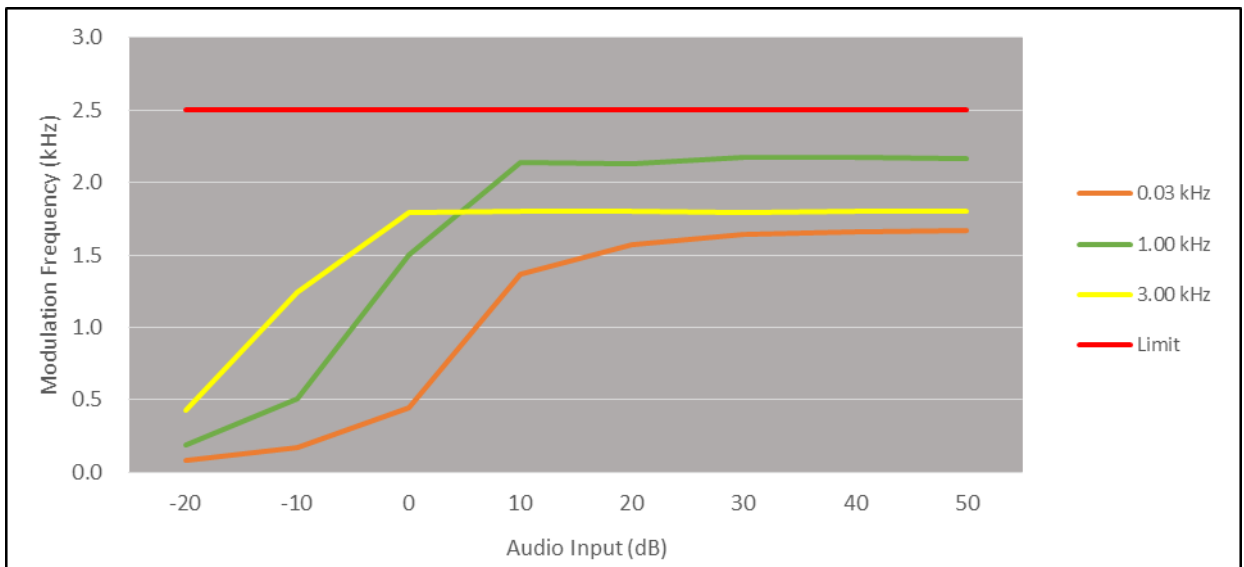

450.05 MHz

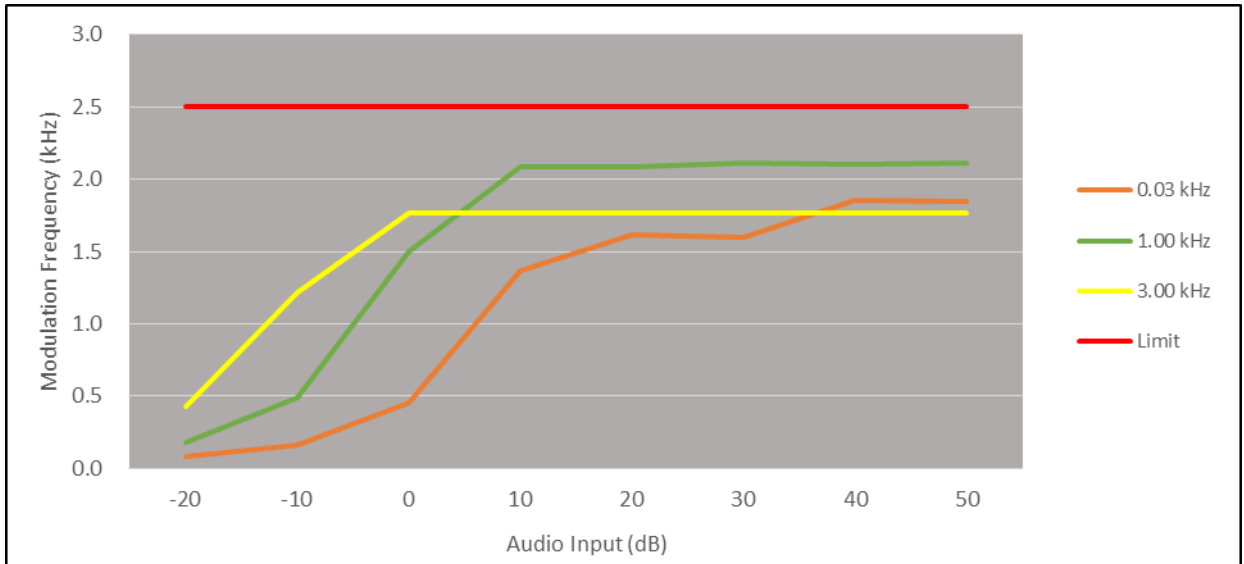

469.95 MHz

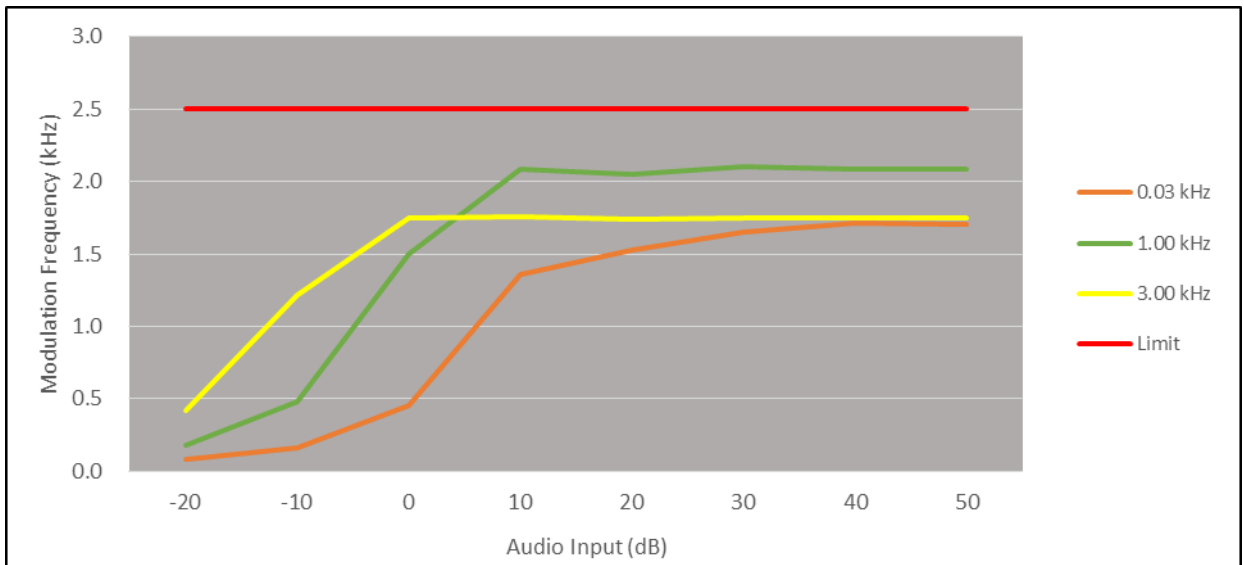

LOW POWER

406.15 MHz

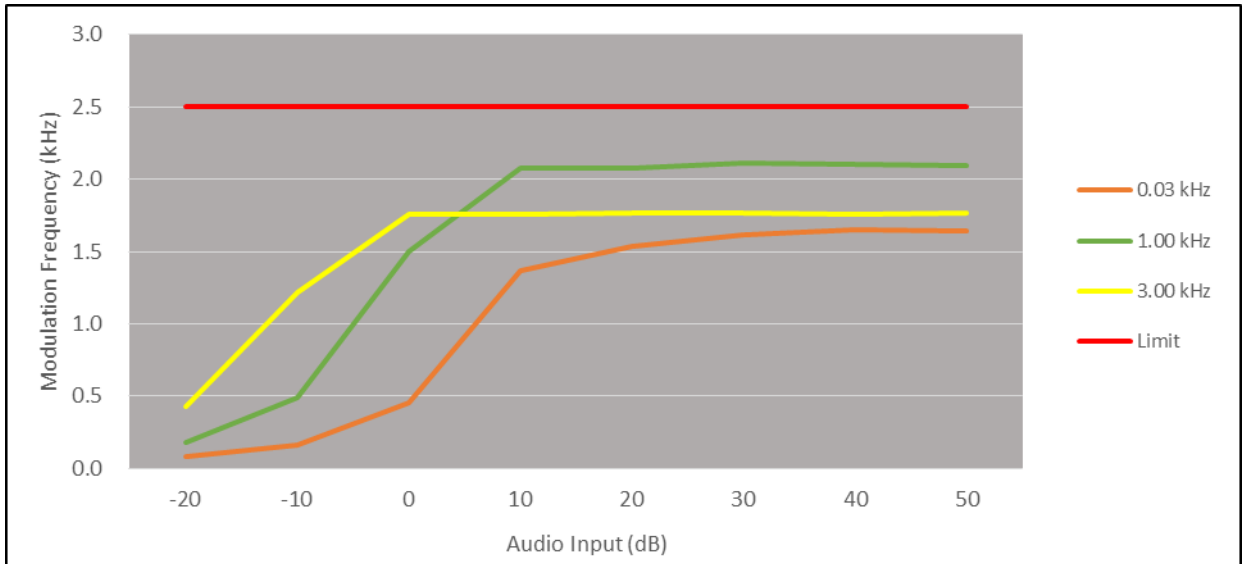

429.95 MHz

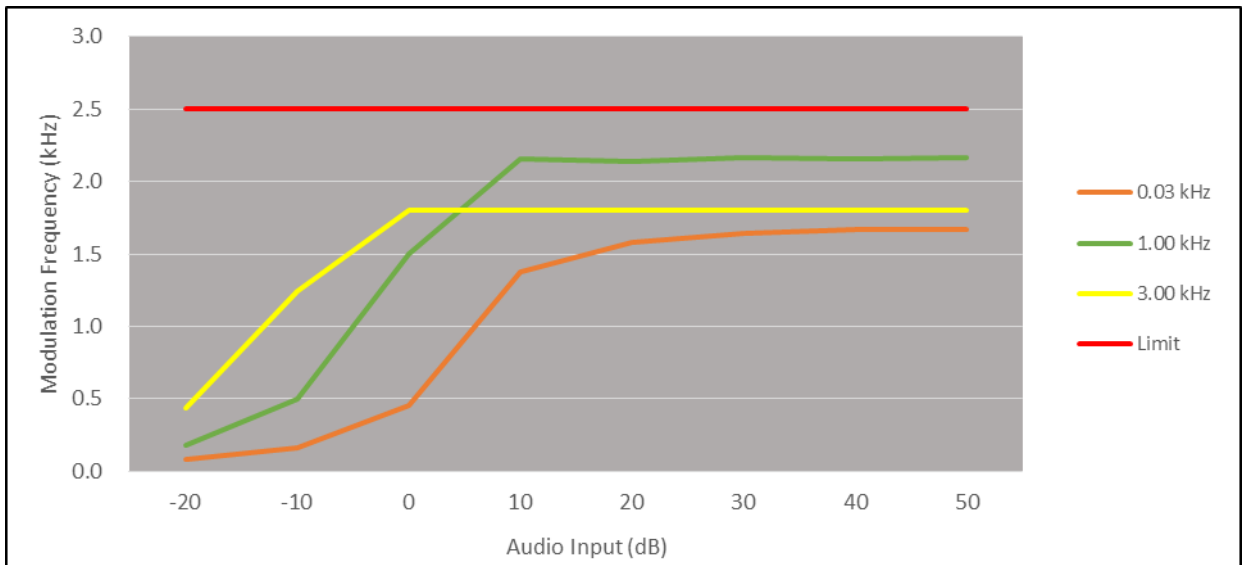

450.05 MHz

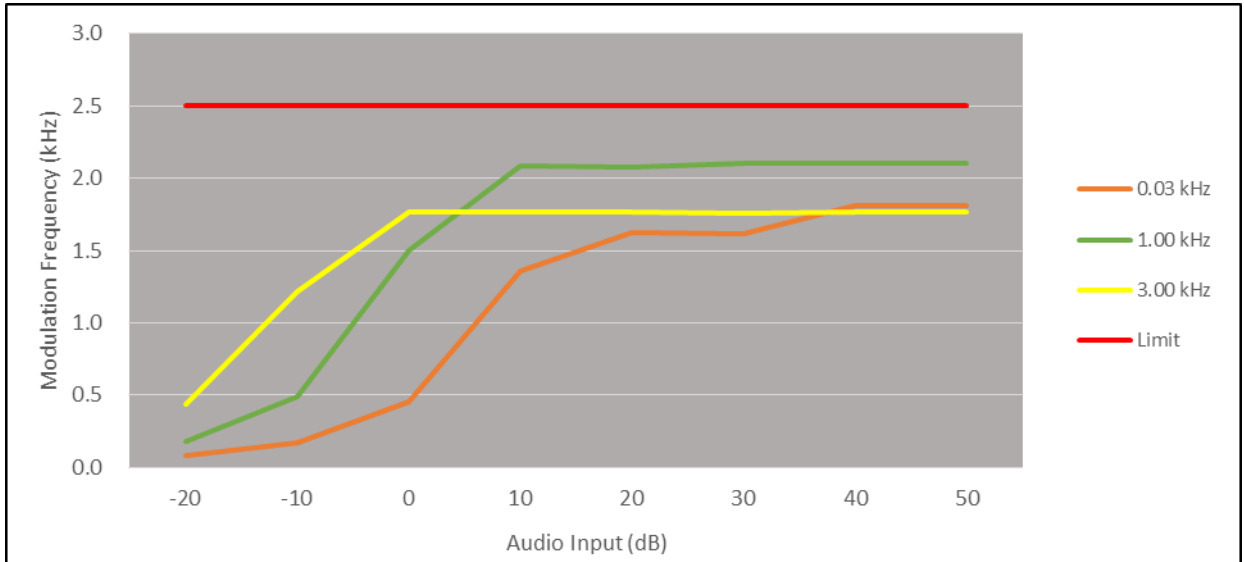

469.95 MHz

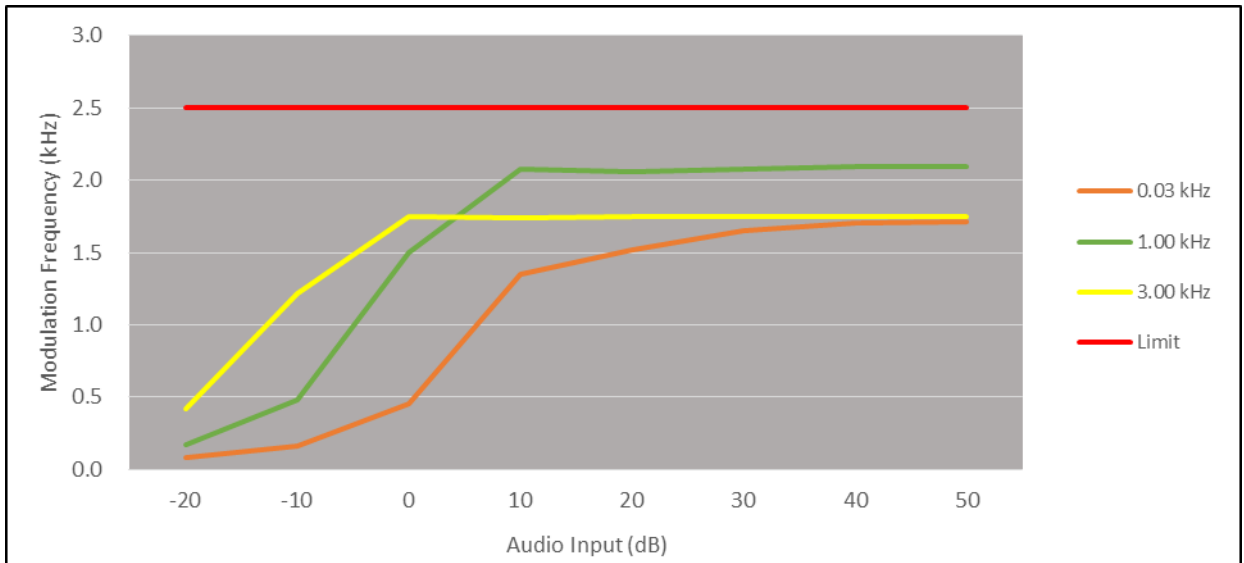

TEST RESULTS(16K0F3E)

Positive Peaks

HIGH POWER

406.15 MHz

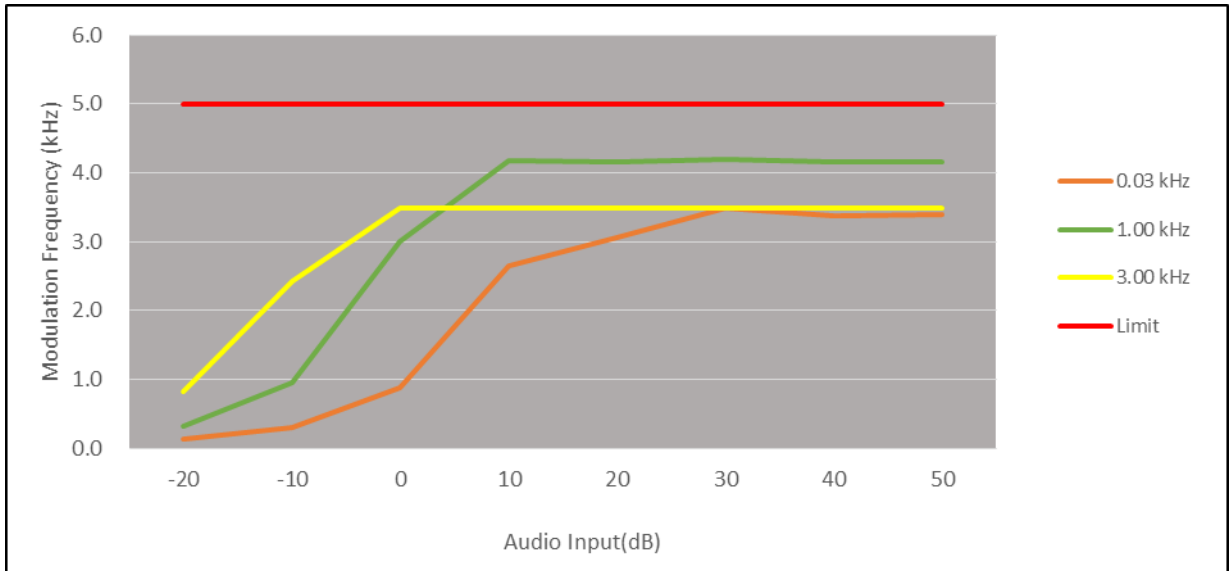

429.95 MHz

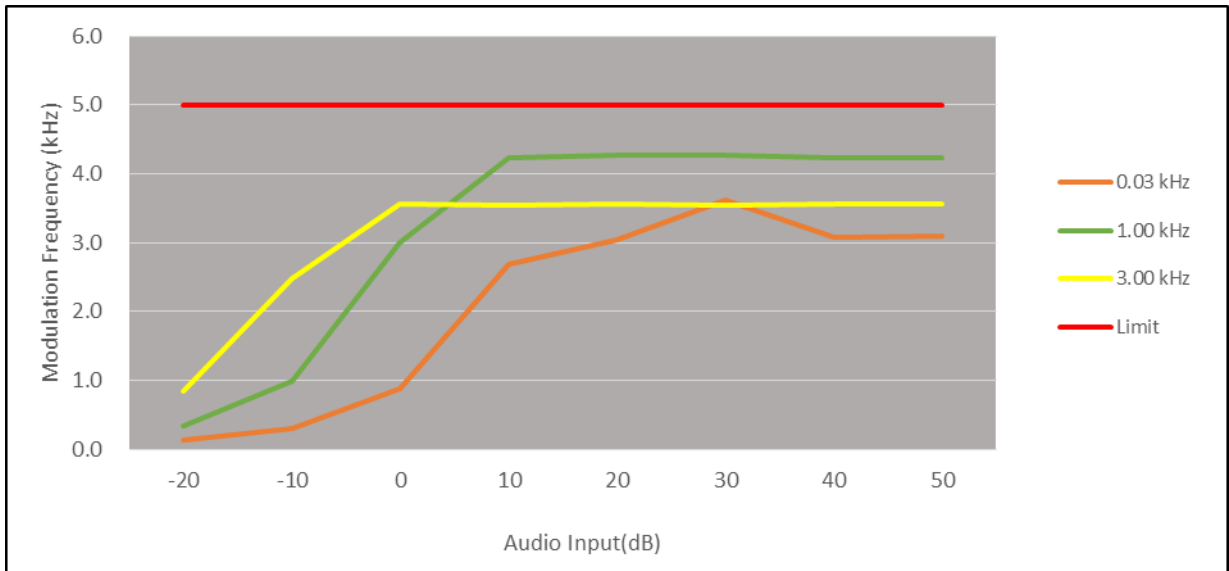

450.05 MHz

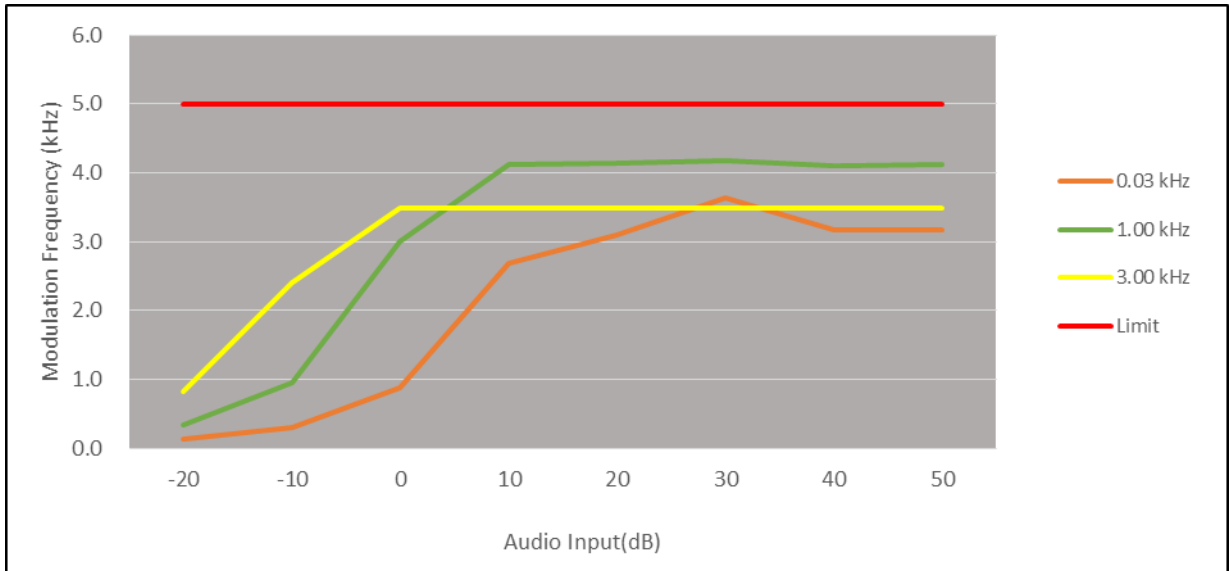

469.95 MHz

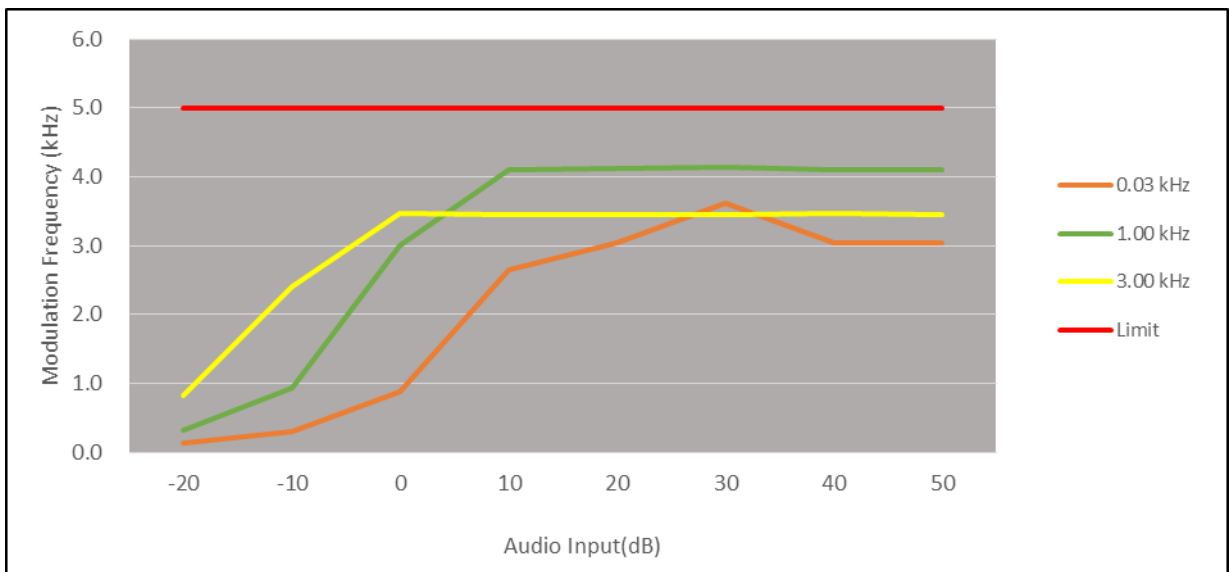

LOW POWER

406.15 MHz

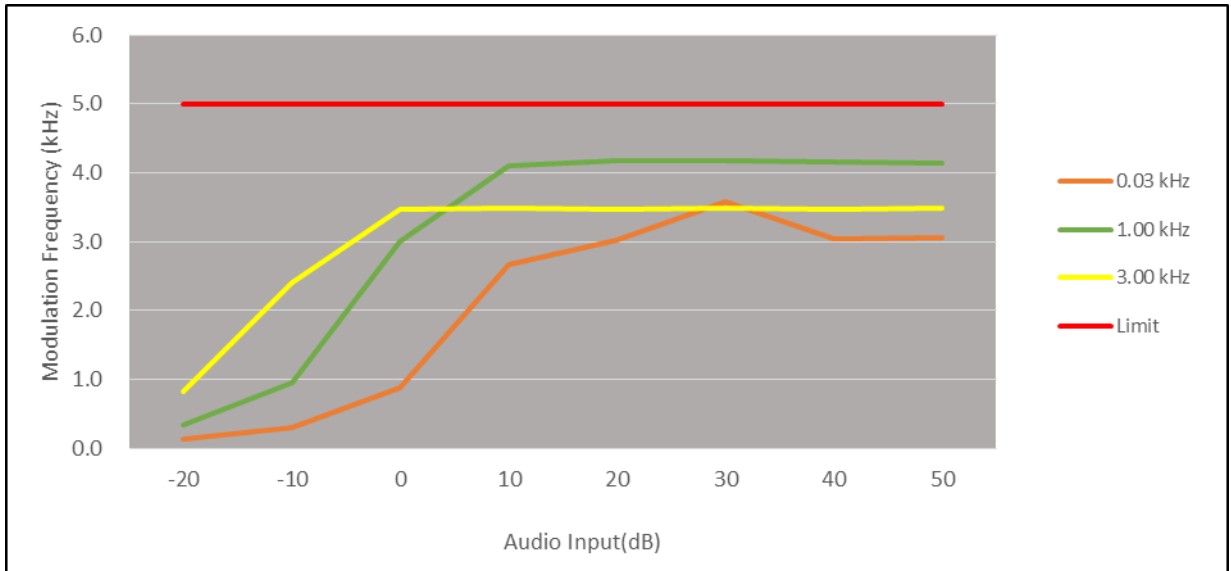

429.95 MHz

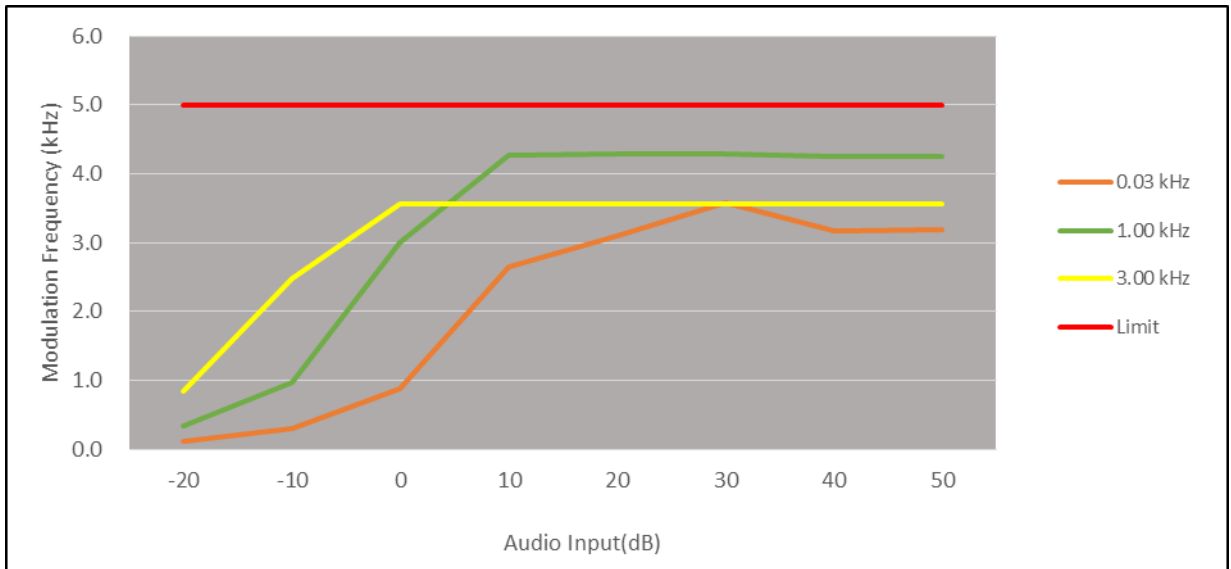

450.05 MHz

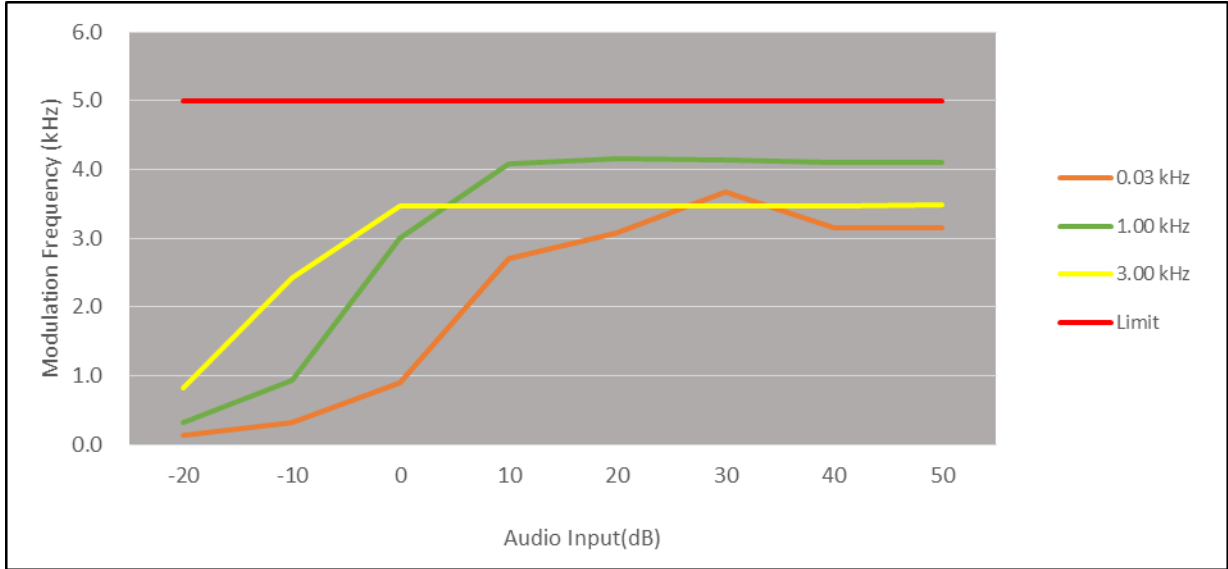

469.95 MHz

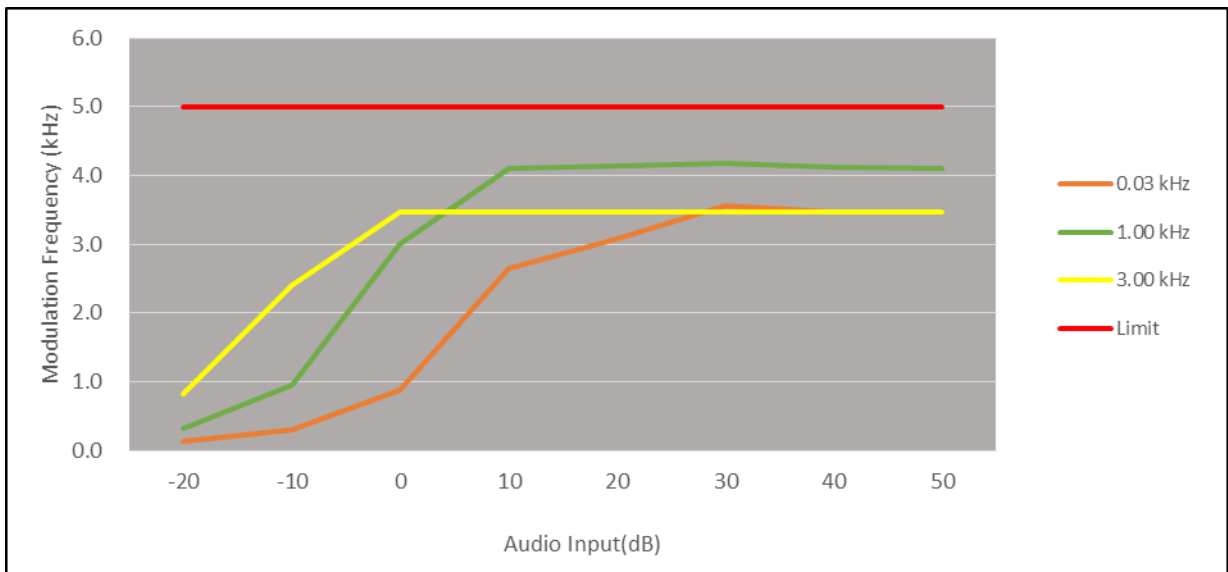

Negative Peaks

HIGH POWER

406.15 MHz

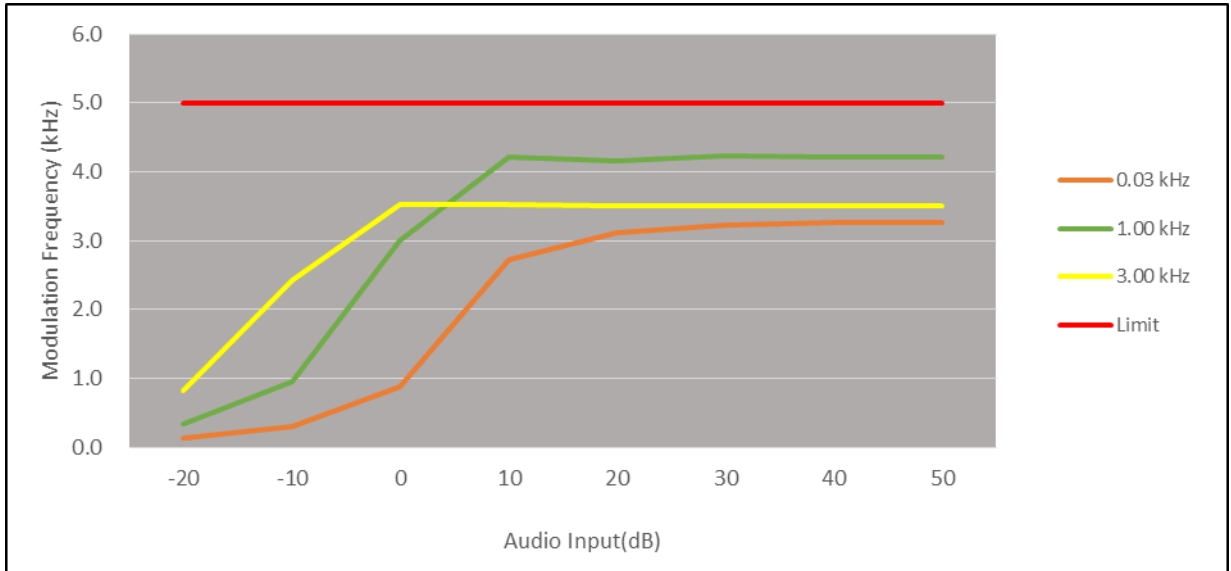

429.95 MHz

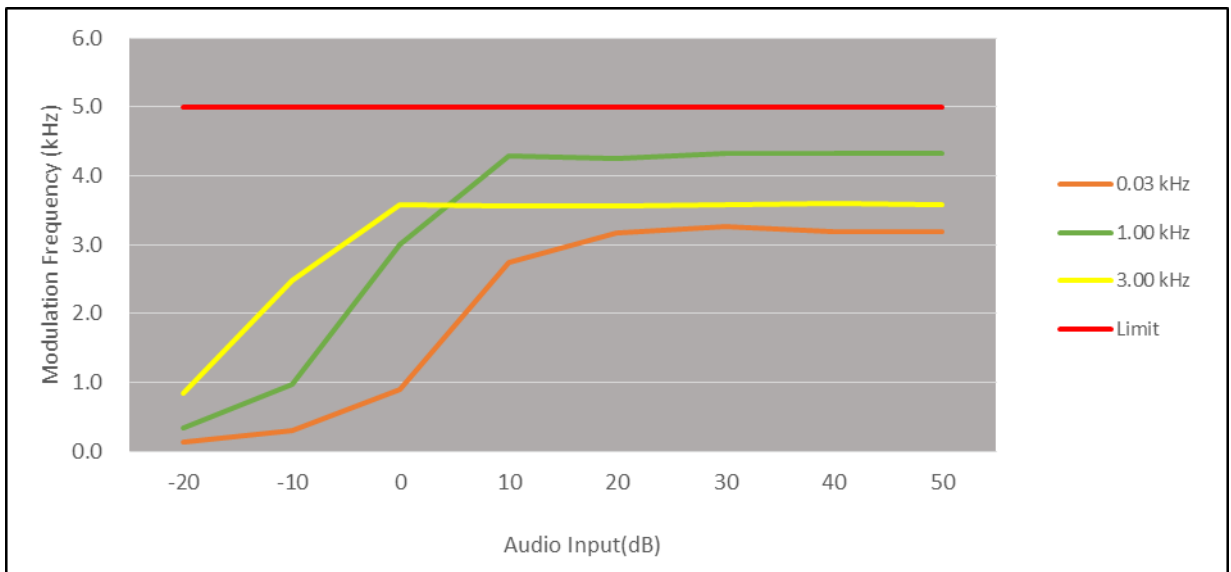

450.05 MHz

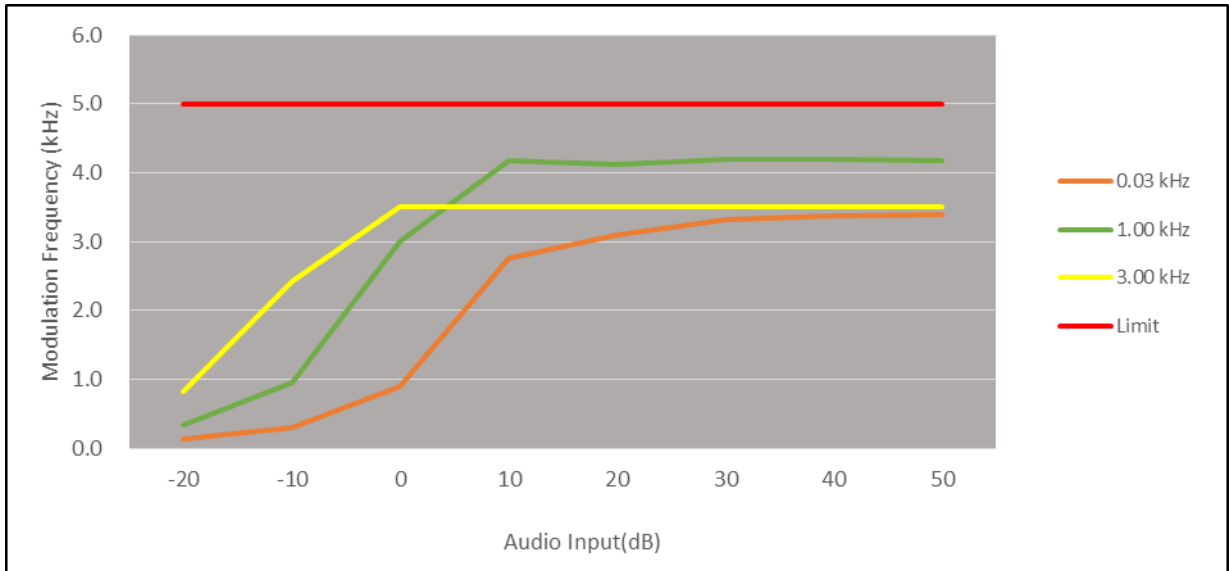

469.95 MHz

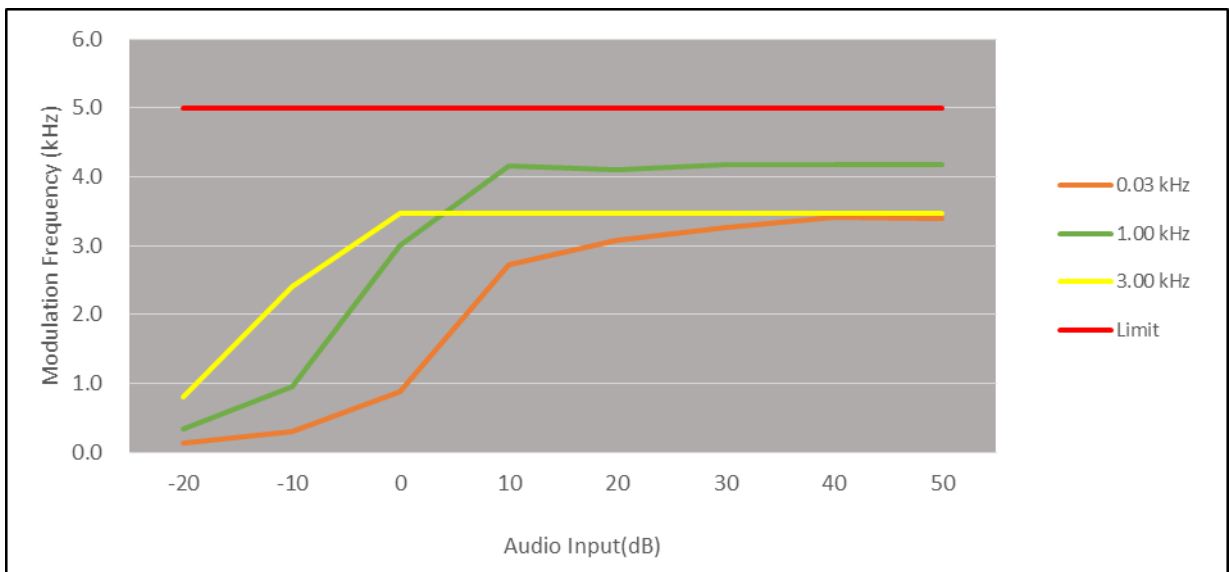

LOW POWER

406.15 MHz

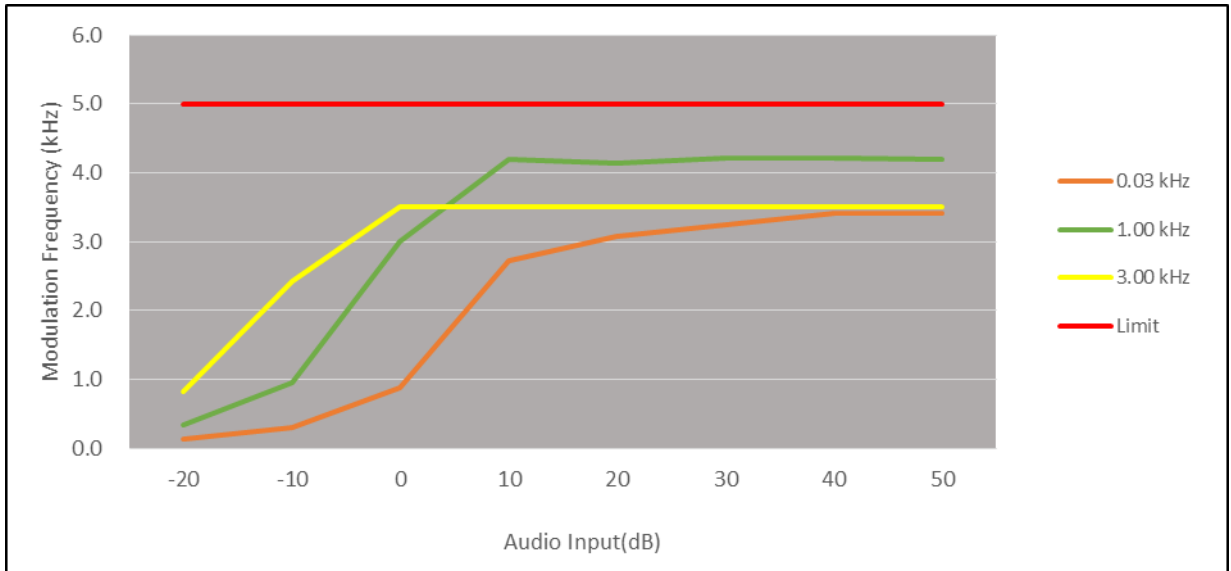

429.95 MHz

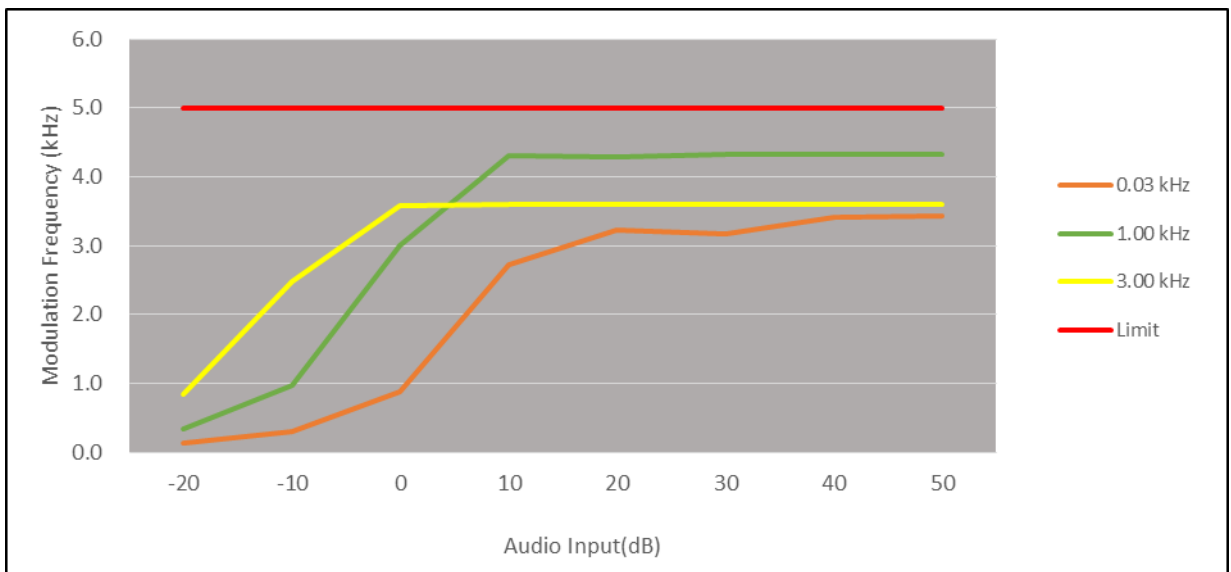

450.05 MHz

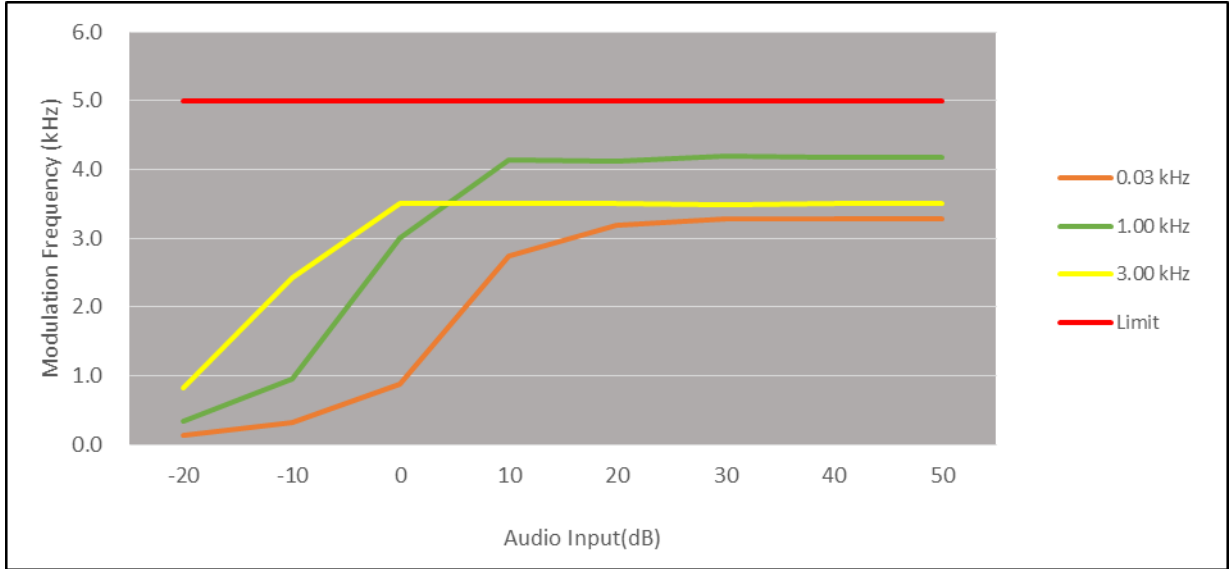

469.95 MHz

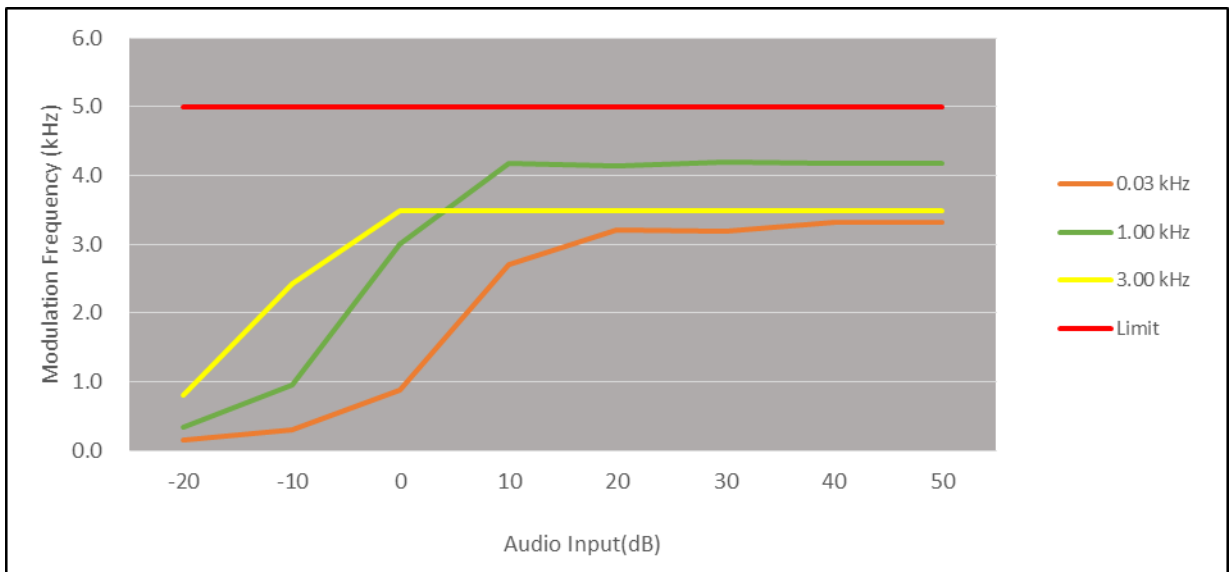

8.5 Audio Frequency Response / Audio Low Pass Filter Response

▣ Definition

The audio frequency response is the degree of closeness to which the frequency deviation of the transmitter follows a prescribed characteristic.

▣ TEST CONFIGURATION

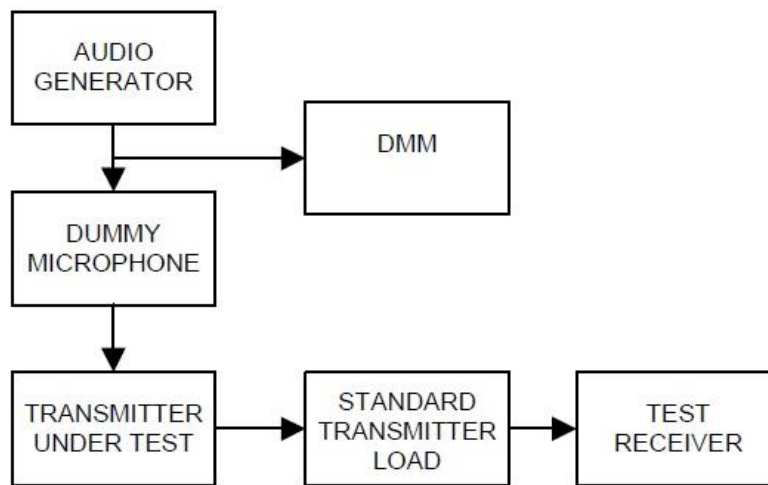

▣ TEST PROCEDURE

According to 2.2.6 in TIA-603-E Standard.

- a) Connect the equipment as illustrated.
- b) Set the test receiver to measure peak positive deviation. Set the audio bandwidth for ≤ 50 Hz to $\geq 15,000$ Hz. Turn the de-emphasis function off.
- c) Set the DMM to measure rms voltage.
- d) Adjust the transmitter per the manufacturer's procedure for full rated system deviation.
- e) Apply a 1000 Hz tone and adjust the audio frequency generator to produce 20% of the rated system deviation.
- f) Set the test receiver to measure rms deviation and record the deviation reading.
- g) Record the DMM reading as V_{REF} .
- h) Set the audio frequency generator to the desired test frequency between 300 Hz and 3000 Hz.
- i) Vary the audio frequency generator output level until the deviation reading that was recorded in step f) is obtained.
- j) Record the DMM reading as V_{FREQ} .
- k) Calculate the audio frequency response at the present frequency as:
 audio frequency response = $20 * \log_{10}(V_{FREQ}/V_{REF})$
- l) Repeat steps h) through k) for all the desired test frequencies.

Note

Audio Filter of the above result is substituted with the same structure as Audio Frequency Response.

On the transmission condition below 3kHz, Transceiver shows pre-emphasis condition of transmission function.

On the transmission condition above 3kHz, Transceiver shows Audio Low Pass Filter.

▣ TEST RESULTS (11K0F3E)

HIGH POWER

406.15 MHz

Frequency (Hz)	Attenuation Rel. to 1kHz (dB)	Upper limit (dB)	Lower limit (dB)
100	-30.26	-18.93	-42.86
125	-30.09	-17.00	-39.00
300	-10.88	-9.42	-23.84
500	-5.93	-5.00	-9.00
750	-2.40	-1.49	-5.49
1000	-0.03	1.00	-3.00
1250	1.74	2.93	-1.07
1500	3.16	4.51	0.51
2000	5.16	7.00	3.00
2500	7.12	8.93	4.93
3000	8.10	10.51	4.93
4000	-24.28	-	-
5000	-28.51	-	-
6000	-28.45	-	-
7000	-28.60	-	-
8000	-28.56	-	-
9000	-28.40	-	-
10000	-28.53	-	-
20000	-28.49	-	-
30000	-28.49	-	-
40000	-28.53	-	-

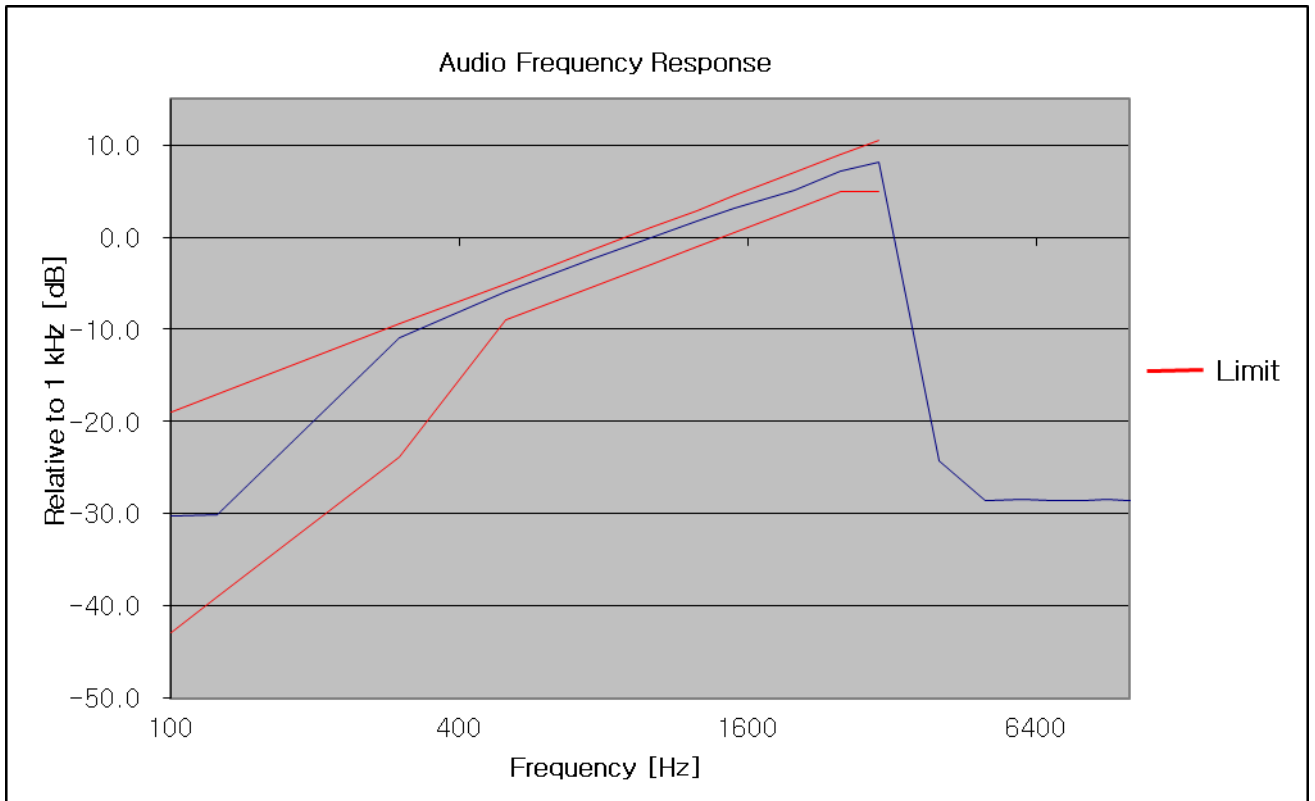

429.95 MHz

Frequency (Hz)	Attenuation Rel. to 1kHz (dB)	Upper limit (dB)	Lower limit (dB)
100	-29.63	-18.93	-42.86
125	-29.92	-17.00	-39.00
300	-10.87	-9.42	-23.84
500	-5.90	-5.00	-9.00
750	-2.39	-1.49	-5.49
1000	0.00	1.00	-3.00
1250	1.73	2.93	-1.07
1500	3.19	4.51	0.51
2000	5.18	7.00	3.00
2500	7.11	8.93	4.93
3000	8.12	10.51	4.93
4000	-27.21	-	-
5000	-28.45	-	-
6000	-28.39	-	-
7000	-28.49	-	-
8000	-28.43	-	-
9000	-28.37	-	-
10000	-28.39	-	-
20000	-28.41	-	-
30000	-28.45	-	-
40000	-28.43	-	-

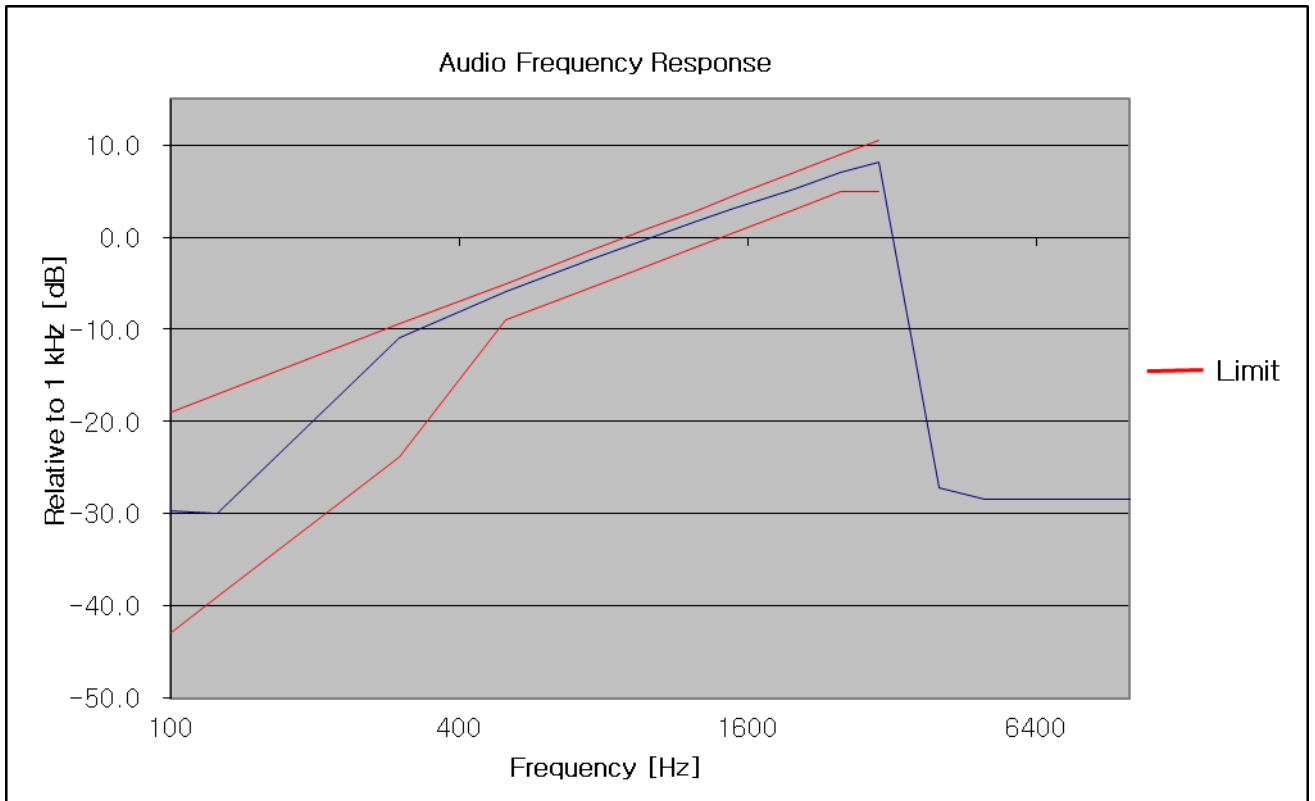

450.05 MHz

Frequency (Hz)	Attenuation Rel. to 1kHz (dB)	Upper limit (dB)	Lower limit (dB)
100	-29.07	-18.93	-42.86
125	-29.37	-17.00	-39.00
300	-10.67	-9.42	-23.84
500	-5.80	-5.00	-9.00
750	-2.41	-1.49	-5.49
1000	0.00	1.00	-3.00
1250	1.76	2.93	-1.07
1500	3.21	4.51	0.51
2000	5.24	7.00	3.00
2500	7.19	8.93	4.93
3000	8.19	10.51	4.93
4000	-26.53	-	-
5000	-27.83	-	-
6000	-27.89	-	-
7000	-27.91	-	-
8000	-27.91	-	-
9000	-27.95	-	-
10000	-27.91	-	-
20000	-27.87	-	-
30000	-27.89	-	-
40000	-27.91	-	-

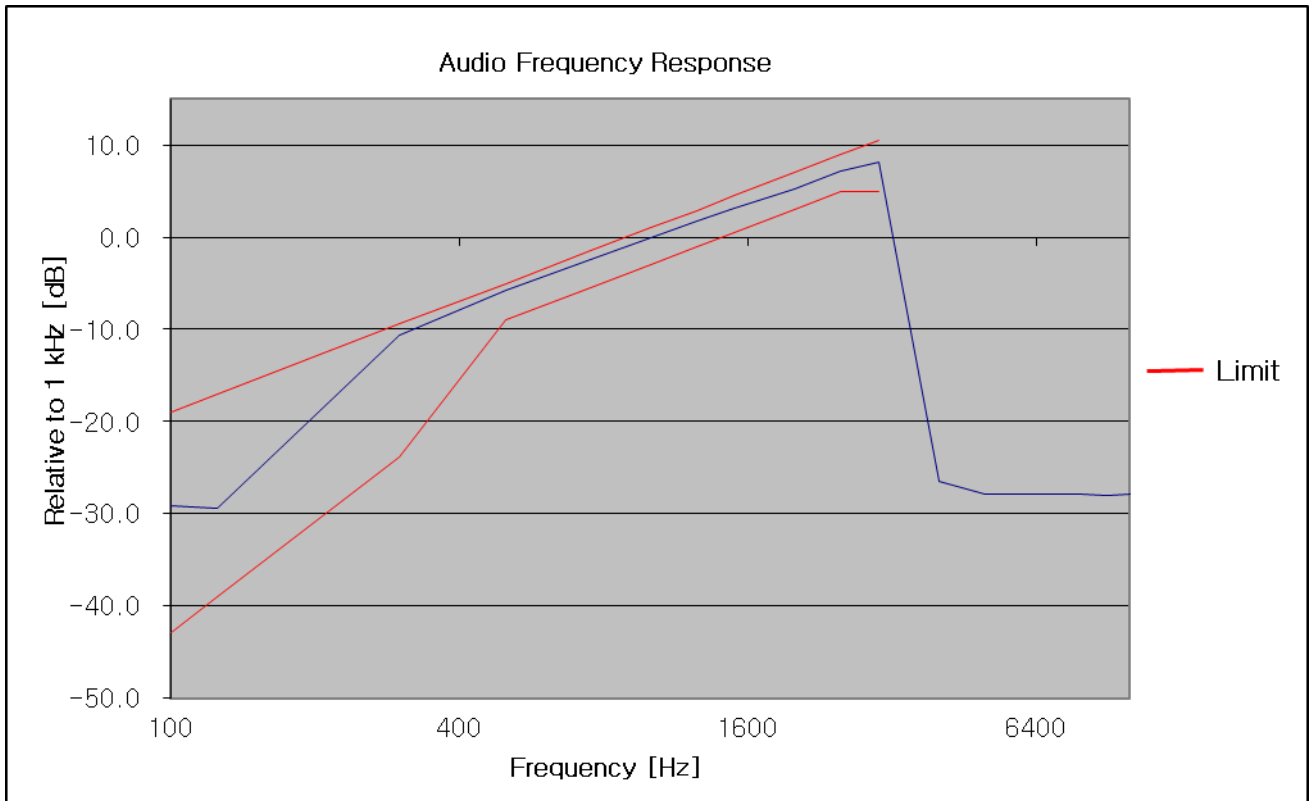

469.95 MHz

Frequency (Hz)	Attenuation Rel. to 1kHz (dB)	Upper limit (dB)	Lower limit (dB)
100	-29.63	-18.93	-42.86
125	-29.55	-17.00	-39.00
300	-10.63	-9.42	-23.84
500	-5.88	-5.00	-9.00
750	-2.40	-1.49	-5.49
1000	-0.03	1.00	-3.00
1250	1.77	2.93	-1.07
1500	3.20	4.51	0.51
2000	5.22	7.00	3.00
2500	7.18	8.93	4.93
3000	8.18	10.51	4.93
4000	-24.64	-	-
5000	-27.62	-	-
6000	-27.46	-	-
7000	-27.52	-	-
8000	-27.62	-	-
9000	-27.56	-	-
10000	-27.60	-	-
20000	-27.64	-	-
30000	-27.52	-	-
40000	-27.66	-	-

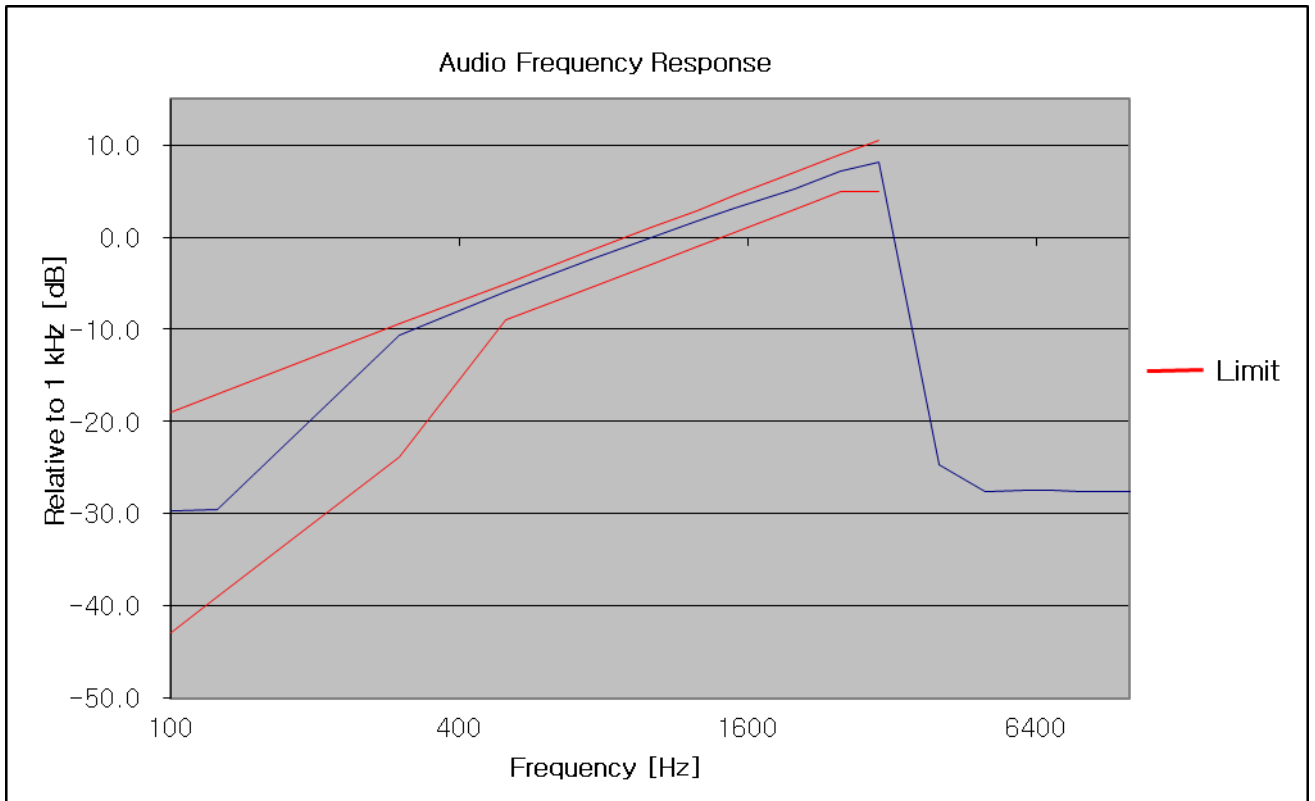

LOW POWER

406.15 MHz

Frequency (Hz)	Attenuation Rel. to 1kHz (dB)	Upper limit (dB)	Lower limit (dB)
100	-29.48	-18.93	-42.86
125	-29.85	-17.00	-39.00
300	-10.68	-9.42	-23.84
500	-5.88	-5.00	-9.00
750	-2.39	-1.49	-5.49
1000	-0.03	1.00	-3.00
1250	1.73	2.93	-1.07
1500	3.18	4.51	0.51
2000	5.20	7.00	3.00
2500	7.15	8.93	4.93
3000	8.15	10.51	4.93
4000	-26.14	-	-
5000	-28.37	-	-
6000	-28.39	-	-
7000	-28.33	-	-
8000	-28.39	-	-
9000	-28.39	-	-
10000	-28.41	-	-
20000	-28.45	-	-
30000	-28.39	-	-
40000	-28.41	-	-

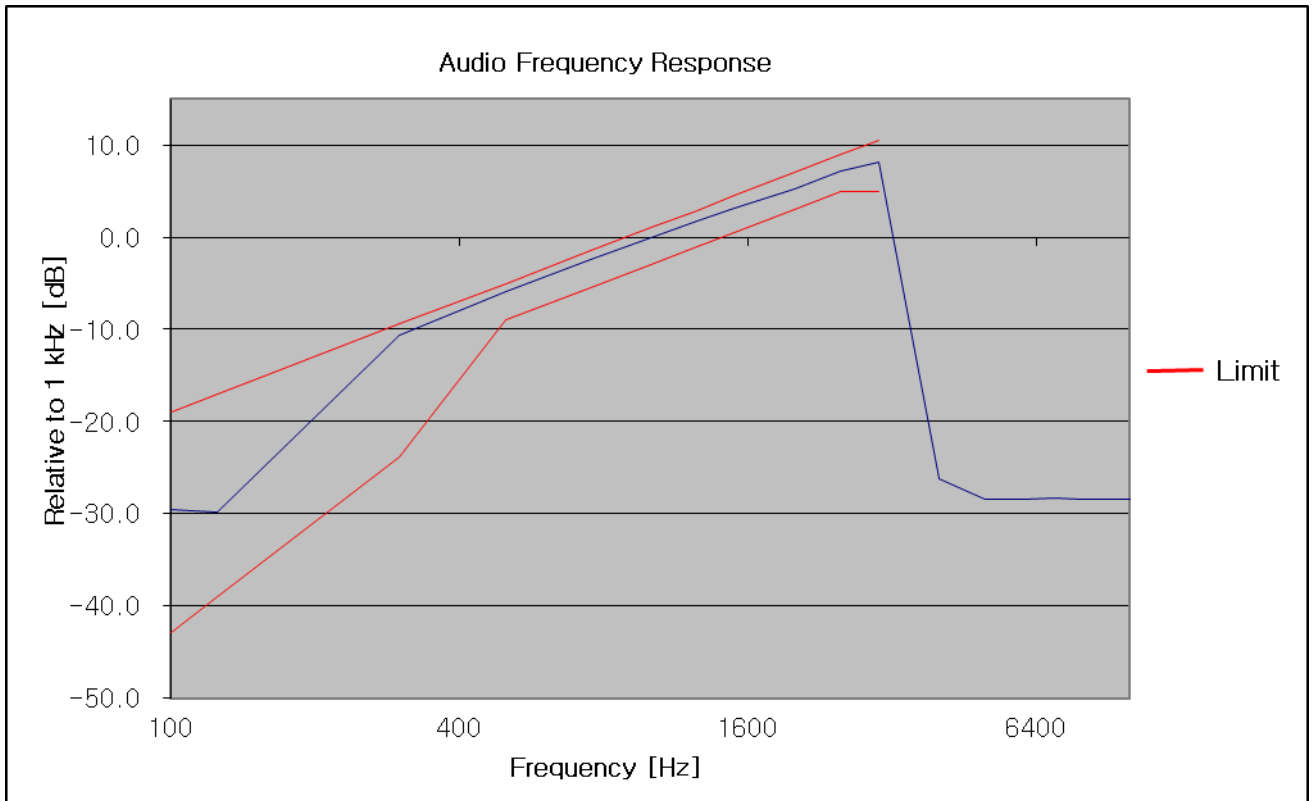

429.95 MHz

Frequency (Hz)	Attenuation Rel. to 1kHz (dB)	Upper limit (dB)	Lower limit (dB)
100	-29.90	-18.93	-42.86
125	-29.53	-17.00	-39.00
300	-10.90	-9.42	-23.84
500	-5.90	-5.00	-9.00
750	-2.36	-1.49	-5.49
1000	0.03	1.00	-3.00
1250	1.76	2.93	-1.07
1500	3.19	4.51	0.51
2000	5.21	7.00	3.00
2500	7.15	8.93	4.93
3000	8.15	10.51	4.93
4000	-26.35	-	-
5000	-28.37	-	-
6000	-28.33	-	-
7000	-28.28	-	-
8000	-28.42	-	-
9000	-28.37	-	-
10000	-28.34	-	-
20000	-28.33	-	-
30000	-28.38	-	-
40000	-28.38	-	-

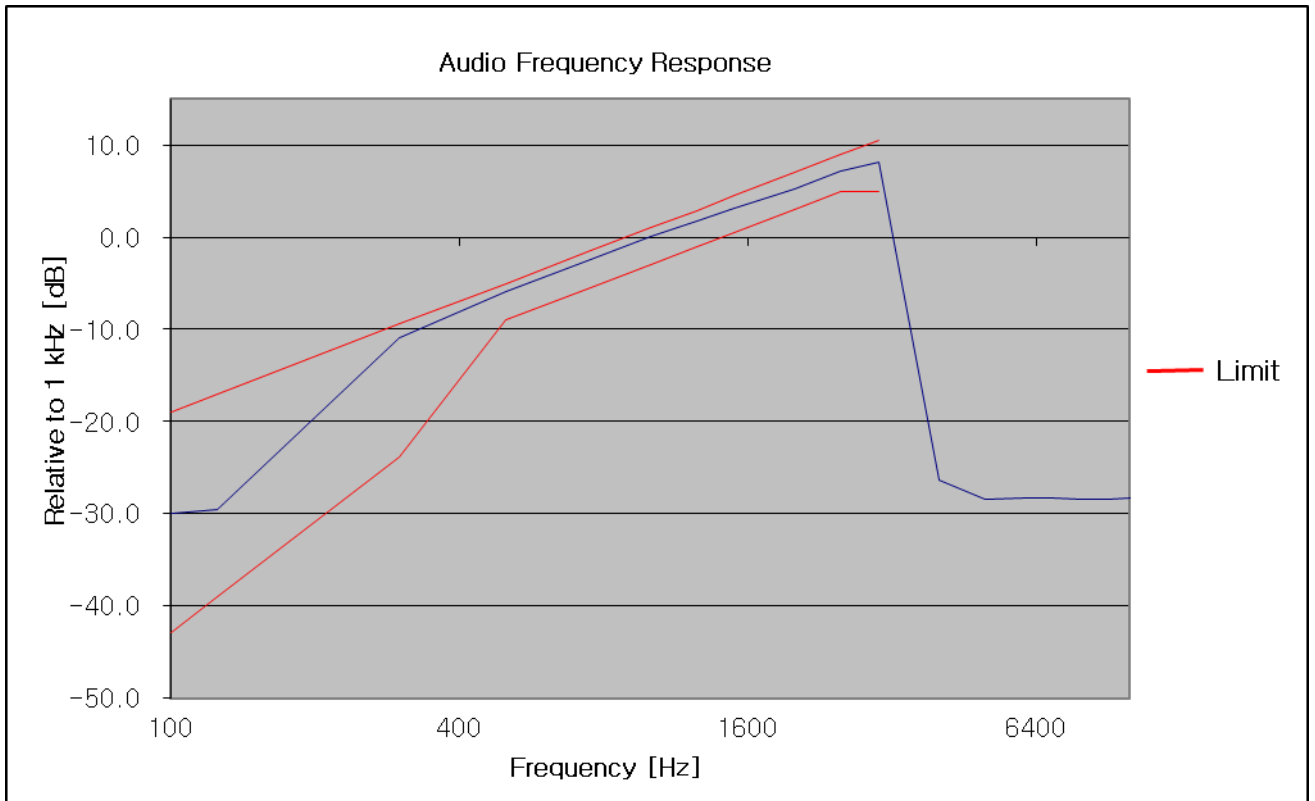

450.05 MHz

Frequency (Hz)	Attenuation Rel. to 1kHz (dB)	Upper limit (dB)	Lower limit (dB)
100	-29.07	-18.93	-42.86
125	-29.15	-17.00	-39.00
300	-10.56	-9.42	-23.84
500	-5.78	-5.00	-9.00
750	-2.43	-1.49	-5.49
1000	0.00	1.00	-3.00
1250	1.76	2.93	-1.07
1500	3.21	4.51	0.51
2000	5.23	7.00	3.00
2500	7.17	8.93	4.93
3000	8.20	10.51	4.93
4000	-24.65	-	-
5000	-27.93	-	-
6000	-27.91	-	-
7000	-27.89	-	-
8000	-27.83	-	-
9000	-27.97	-	-
10000	-27.89	-	-
20000	-27.93	-	-
30000	-27.77	-	-
40000	-27.75	-	-