

7.7 Adjacent Channel Power

■ Definition

For 450 MHz – 470 MHz, operating using equipment designed to operate with a 25 kHz channel bandwidth may be authorized up to a 22 kHz bandwidth if the equipment meets the adjacent channel power(ACP) limits. A measurement bandwidth is 18 kHz.

■ TEST CONFIGURATION

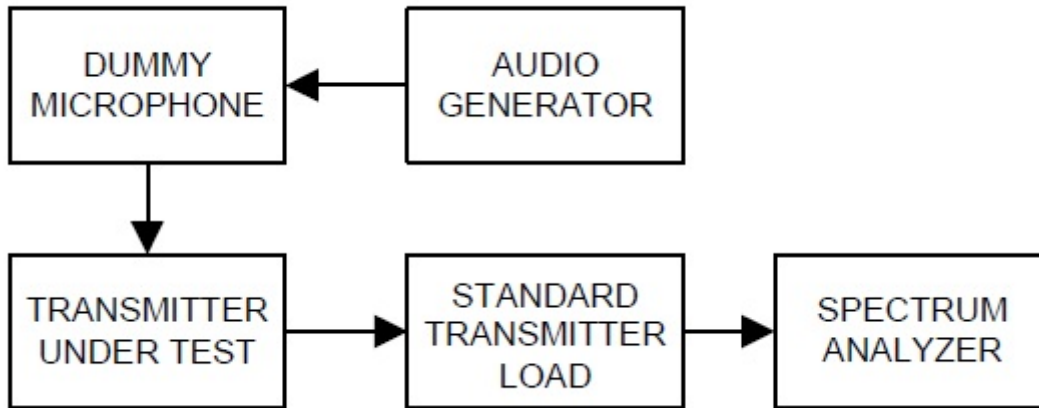

■ Limit

Frequency offset(kHz)	Maximum ACP(dBc) for devices 1 watt and less	Maximum ACP(dBc) for devices above 1 watt
25	-55	-60
50	-70	-70
75	-70	-70

■ TEST RESULTS(only 16K0F3E)

Frequency(MHz)	Frequency offset(kHz)	Lower(dBc)	Upper(dBc)
450.05 (High Power)	25	-74.50	-73.55
	50	-77.40	-78.13
	75	-78.61	-79.27
460.05 (High Power)	25	-73.05	-72.30
	50	-74.71	-74.91
	75	-74.73	-74.88
469.95 (High Power)	25	-75.06	-74.24
	50	-77.25	-77.80
	75	-78.54	-79.10
450.05 (Low Power)	25	-72.02	-70.63
	50	-75.26	-75.48
	75	-77.23	-78.06
460.05 (Low Power)	25	-71.14	-69.79
	50	-73.14	-73.09
	75	-73.85	-74.23
469.95 (Low Power)	25	-74.39	-71.31
	50	-76.89	-76.57
	75	-78.23	-78.55

■ Plots of Adjacent Channel Power

(16K0F3E _ 450.05 MHz)_High

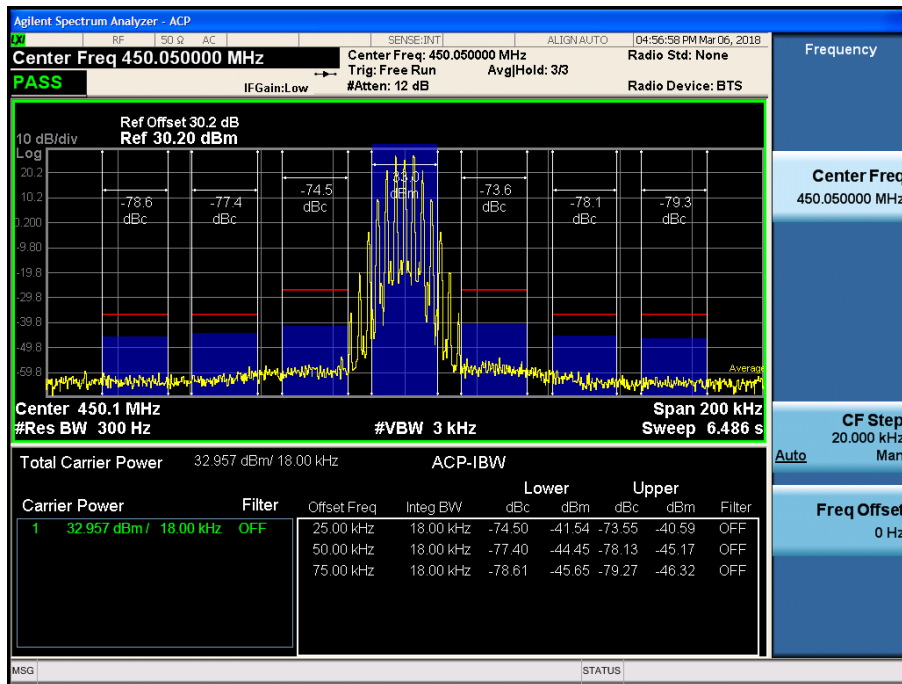

(16K0F3E _ 460.05 MHz)_High

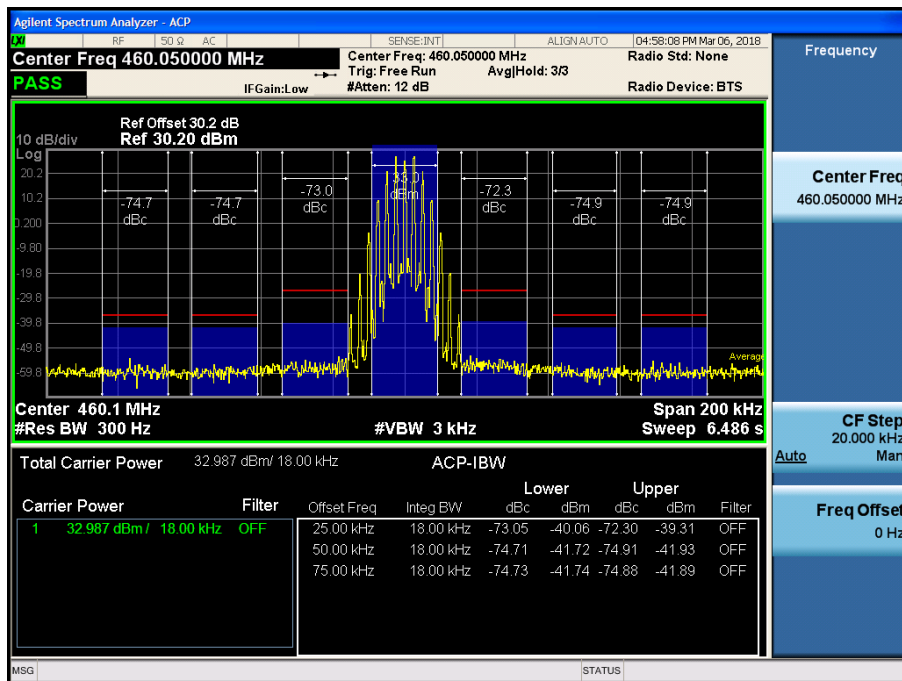

(16K0F3E _ 469.95 MHz)_High

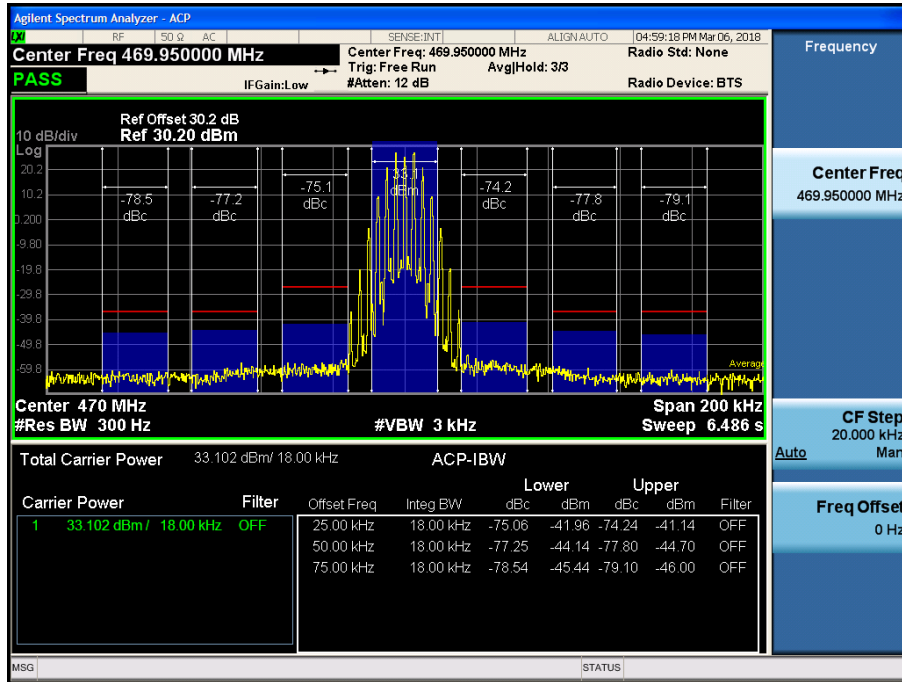

(16K0F3E _ 450.05 MHz)_Low

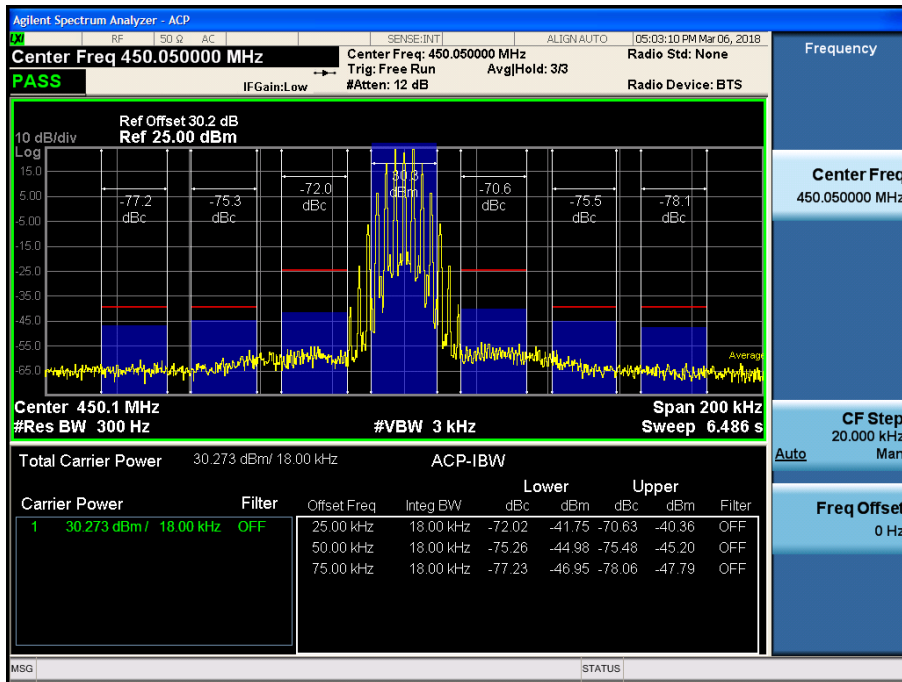

(16K0F3E _ 460.05 MHz)_Low

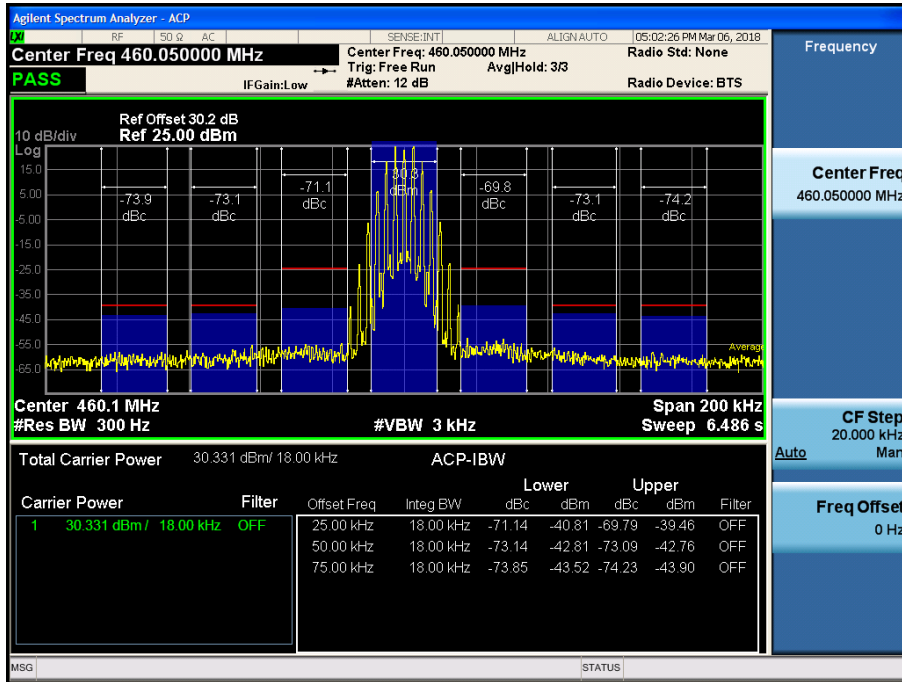

(16K0F3E _ 469.95 MHz)_Low

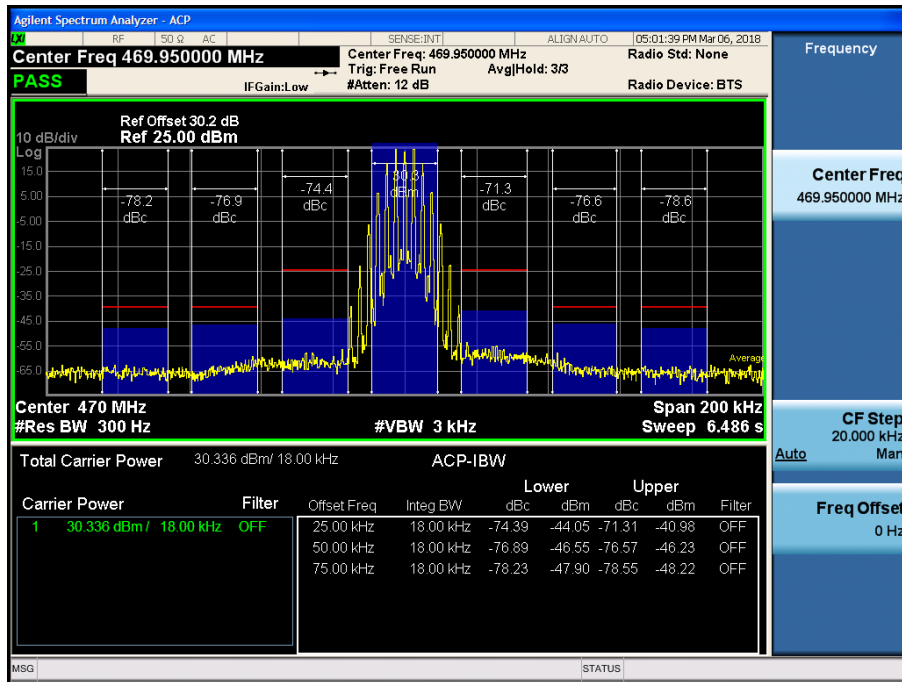

7.8 Transient Frequency Behavior

■ Definition

Transient frequency behavior is a measure of the difference, as a function in time, of the actual transmitter frequency to the assigned transmitter frequency when the transmitted RF output power is switched on or off.

■ TEST CONFIGURATION

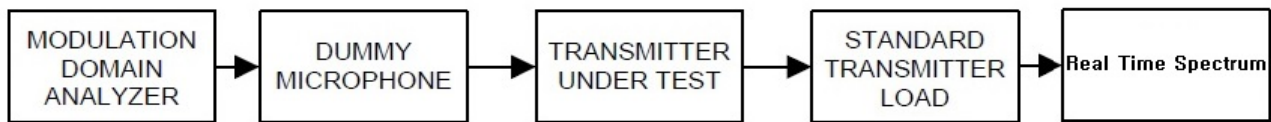

■ TEST PROCEDURE

According to 2.2.19 in TIA-603-E Standard.

- a) Connect the equipment as illustrated.
- b) Connect the output of the standard transmitter load to the RF power meter.
Supply sufficient attenuation via the RF attenuator to provide a level that is approximately 40 dB below the maximum allowable input to the modulation domain analyzer.
- c) Unkey the transmitter.
- d) Disconnect the RF power meter and connect the modulation domain analyzer in its place.
Set the envelope trigger of the modulation domain analyzer to the minimum level that will trigger when the transmitter is keyed.
- e) Reduce the attenuation of the RF attenuator so that the input to the modulation domain analyzer is increased by 30 dB when the transmitter is keyed.
- f) Set the modulation domain analyzer to trigger on the rising edge of the waveform in order to capture a single-shot turn-on of the transmitter signal.
- g) Adjust the display of the modulation domain analyzer for proper viewing of the transmitter transient behavior. Set the time base reference to the left for observing the transmitter turn-on transient.
- h) Key the transmitter.
- i) Observe the stored display of the modulation domain analyzer.
The signal trace shall be maintained within the allowable limits during the periods t_1 and t_2 , and shall also remain within limits following t_2 .

- j) Adjust the modulation domain analyzer to trigger on the falling edge of the transmitter waveform in order to capture a single-shot turn-off transient of the transmitter signal.
- k) Adjust the display of the modulation domain analyzer for proper viewing of the transmitter transient behavior. Set the time base reference to the right for observing the transmitter turn-off transient.
- l) Unkey the transmitter.
- m) Observe the stored display of the modulation domain analyzer. The signal trace shall be maintained within the allowable limits during the period t_3 .

Note

Tests were performed all type of emission. And worst case is Analogue type(16K0F3E & 11K0F3E). Therefore, this report attached only Analogue type(16K0F3E & 11K0F3E).

■ Plots of Transient Frequency Behavior

(11K0F3E _ 450.05 MHz)_High

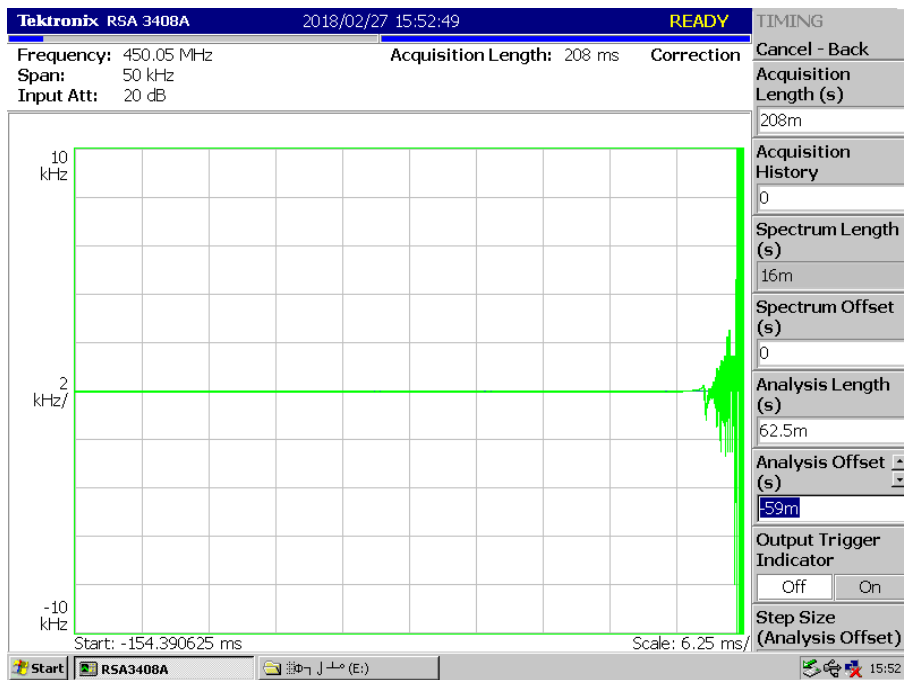
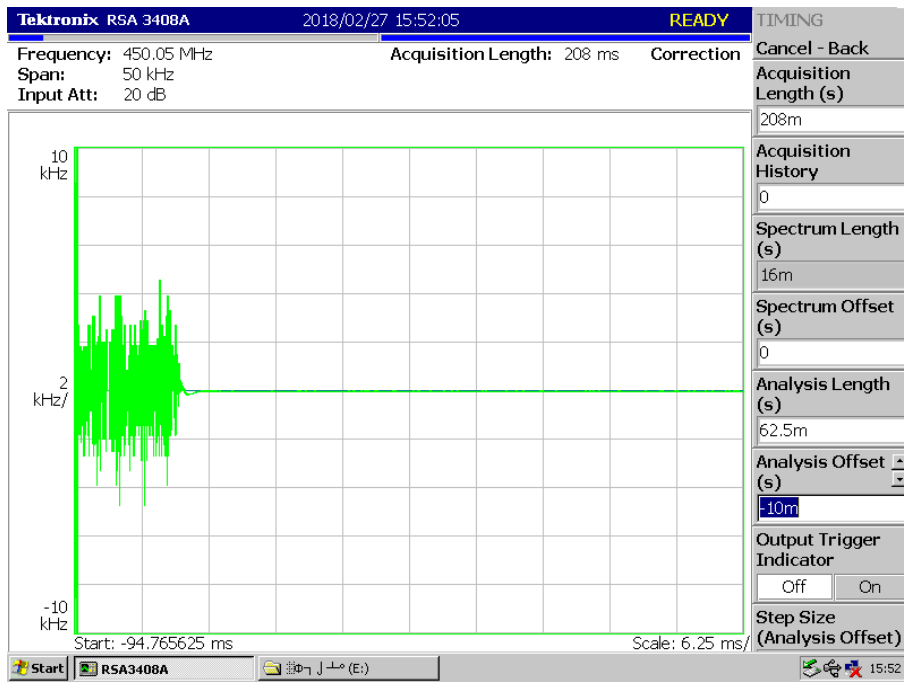

(11K0F3E _ 460.05 MHz)_High

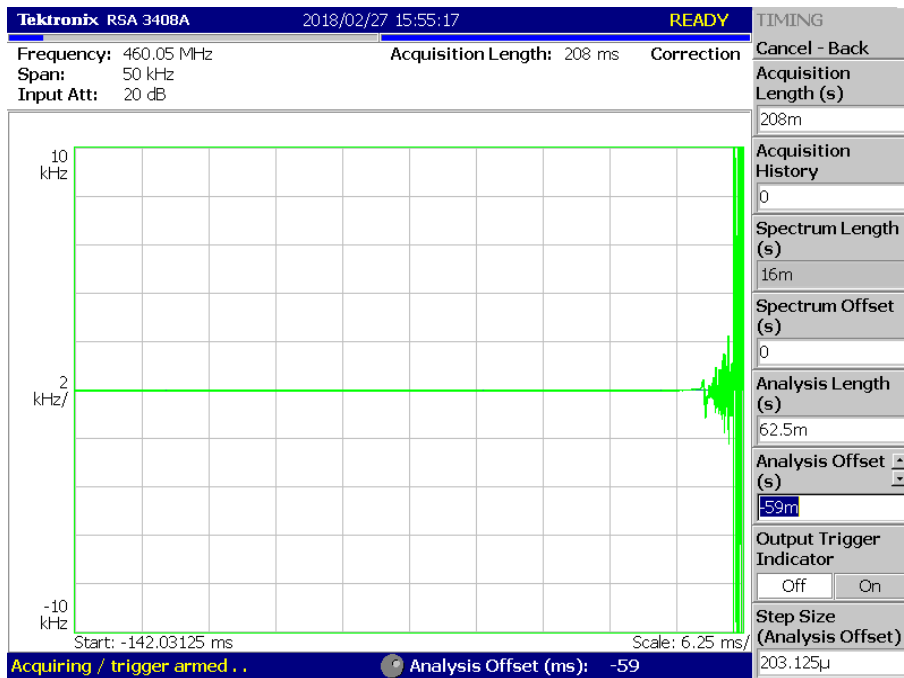
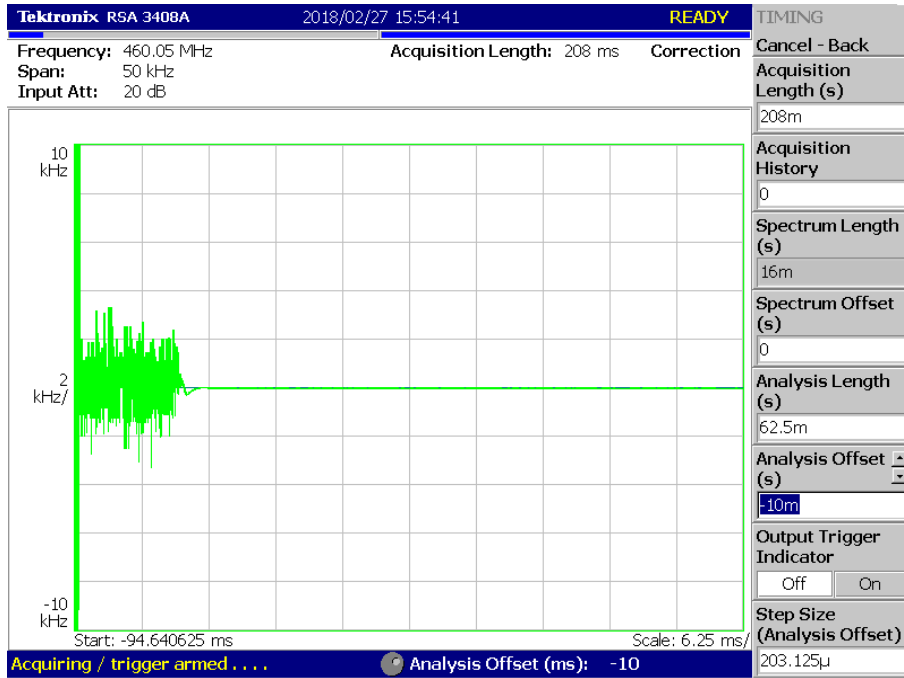

(11K0F3E _ 469.95 MHz)_High

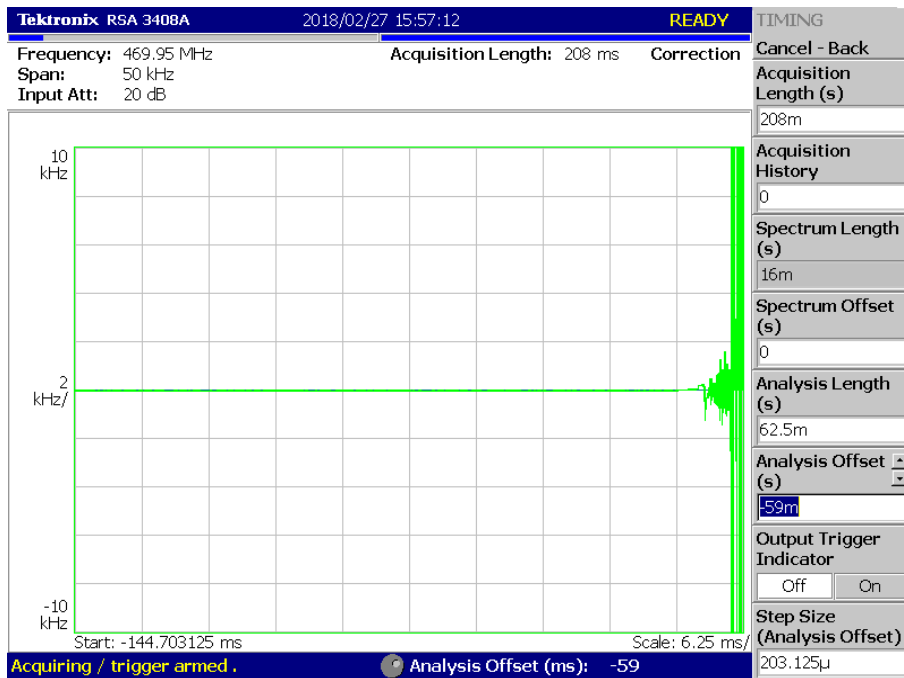
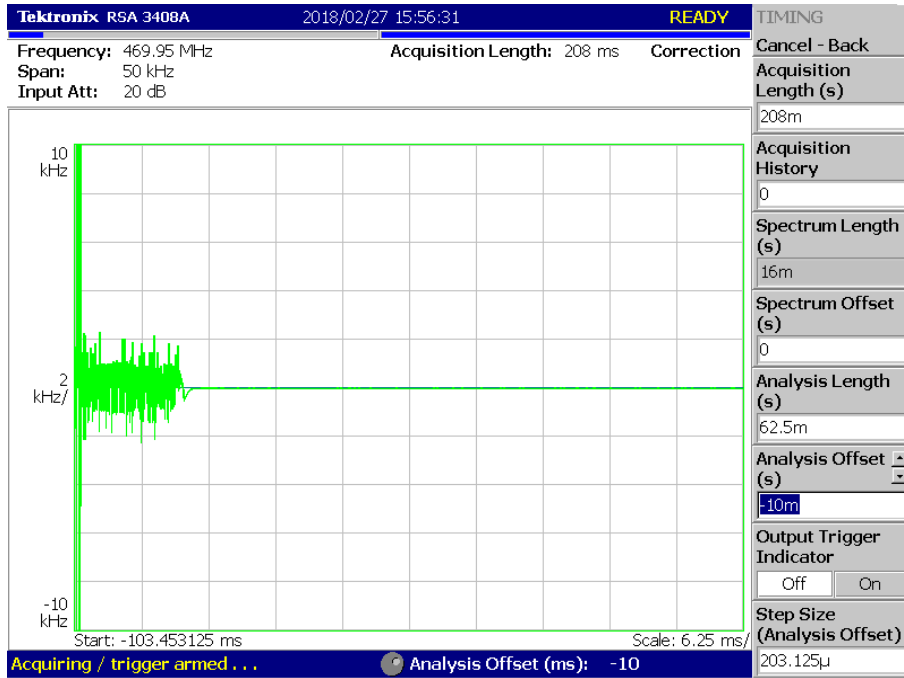

(11K0F3E _ 450.05 MHz)_Low

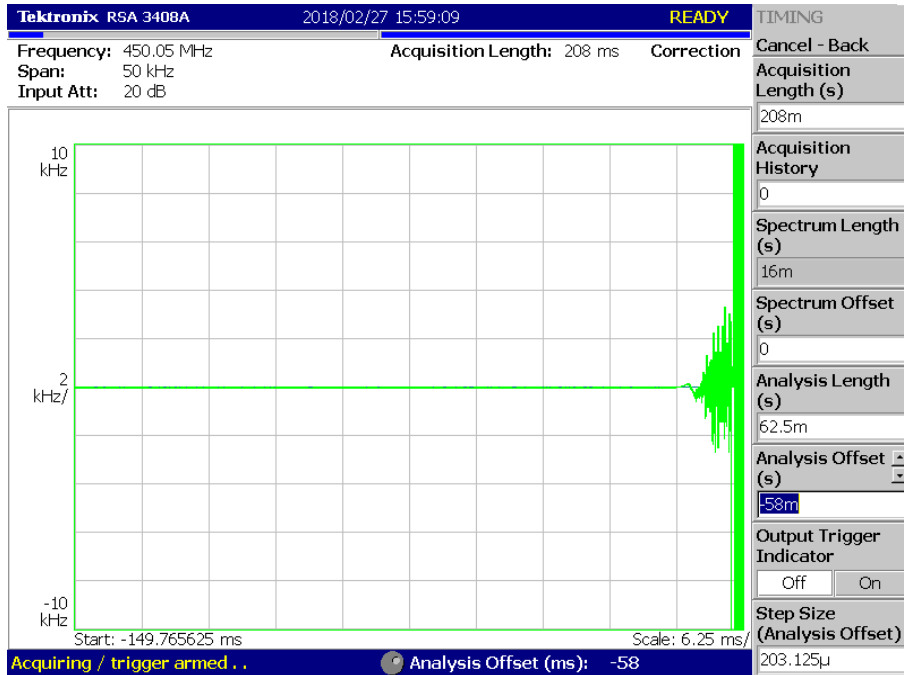
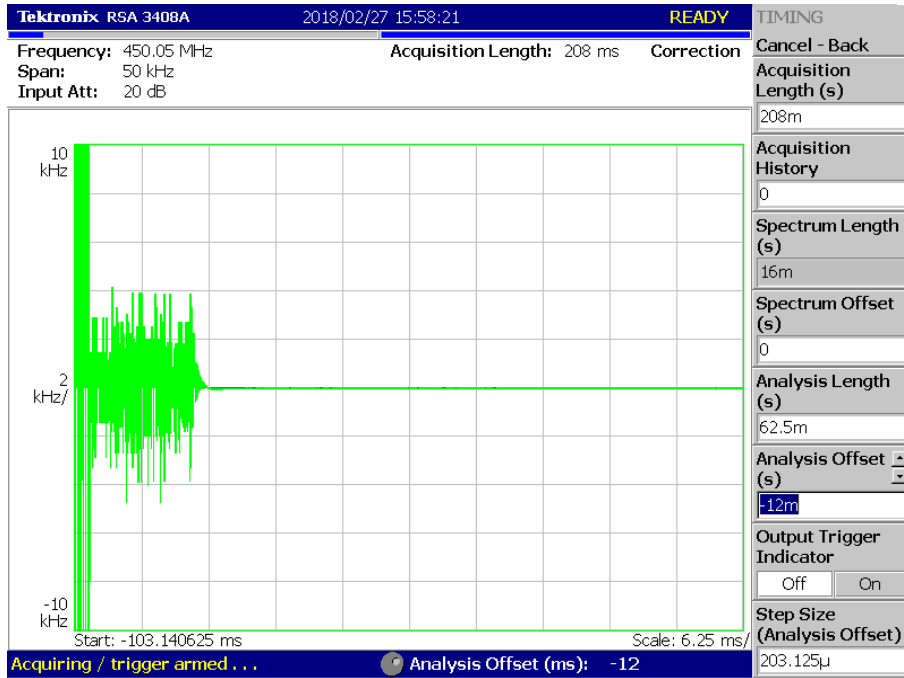

(11K0F3E _ 460.05 MHz)_Low

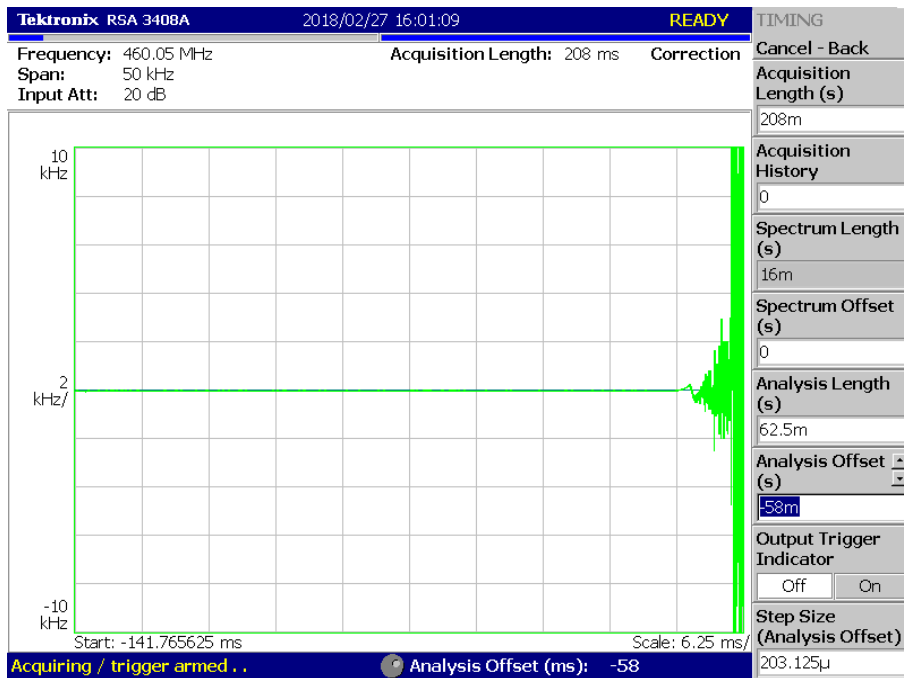
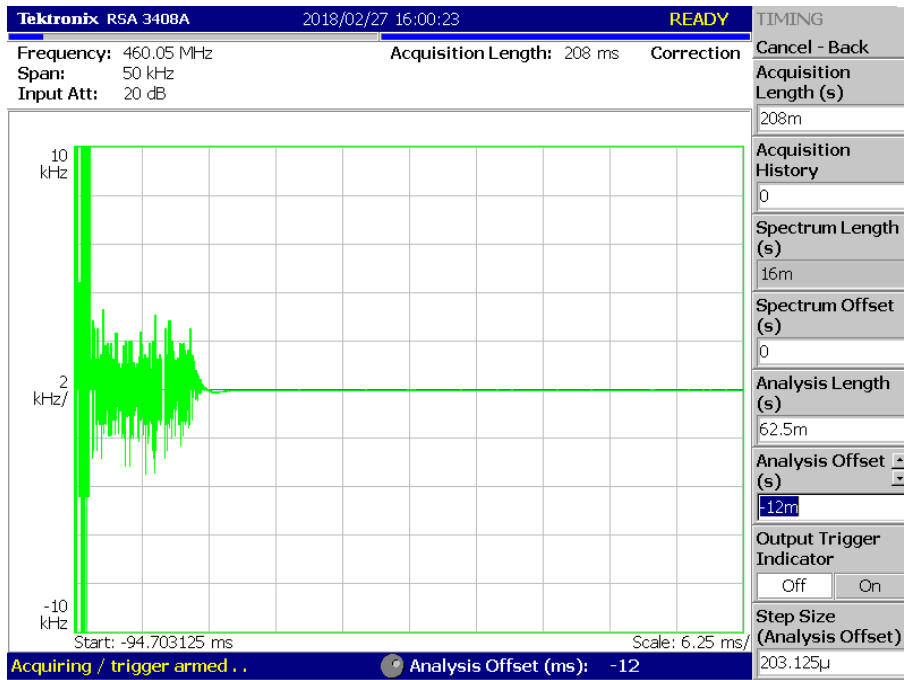

(11K0F3E _ 469.95 MHz)_Low

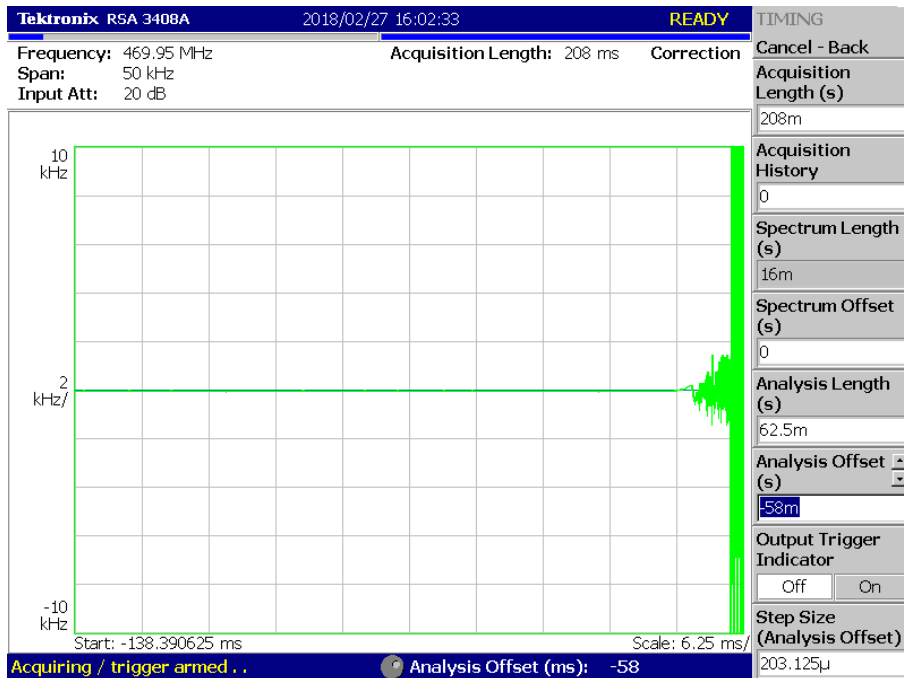
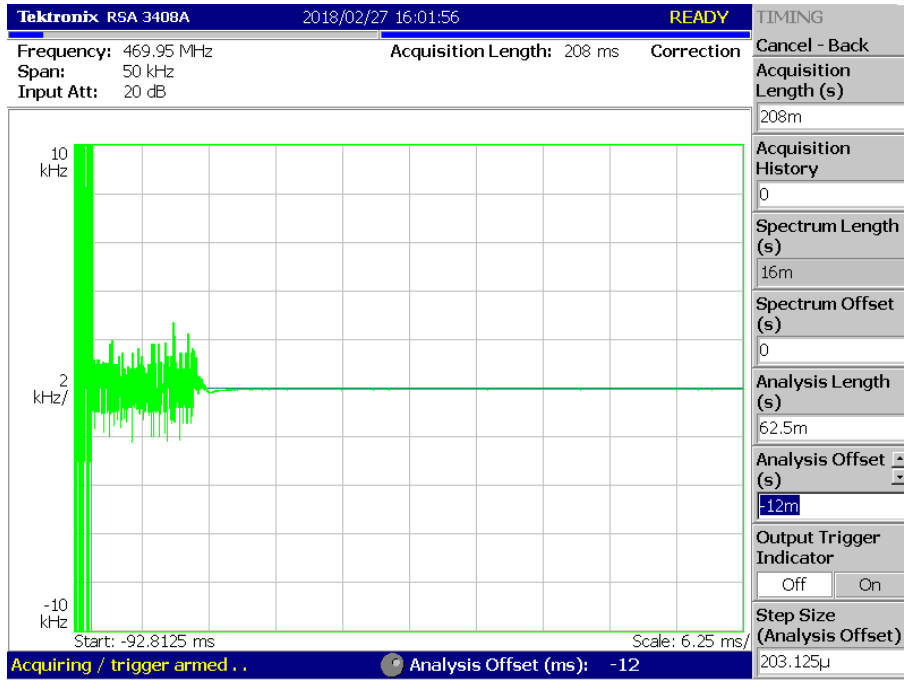

(16K0F3E _ 450.05 MHz)_High

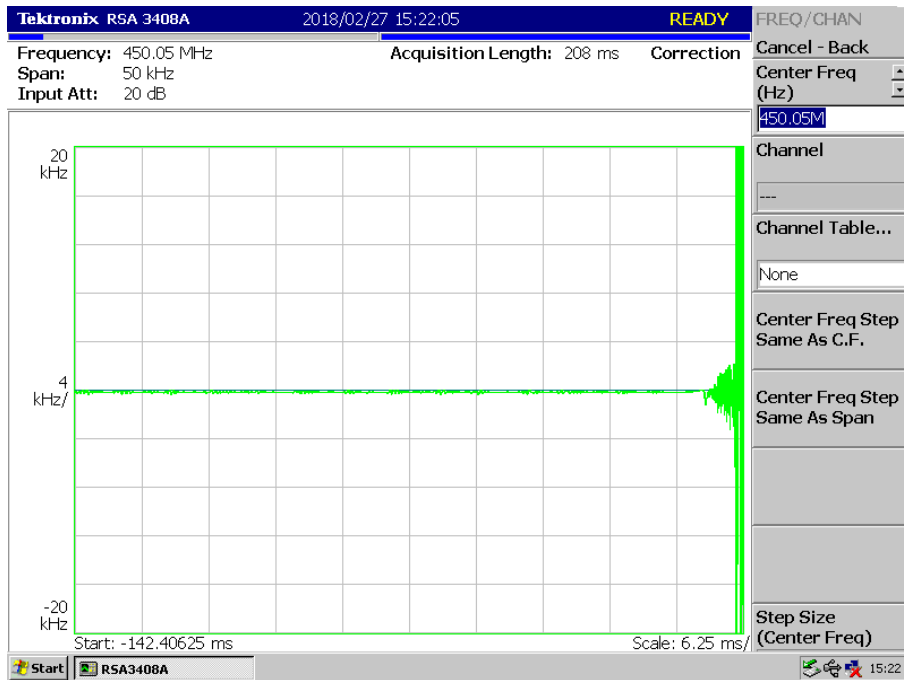
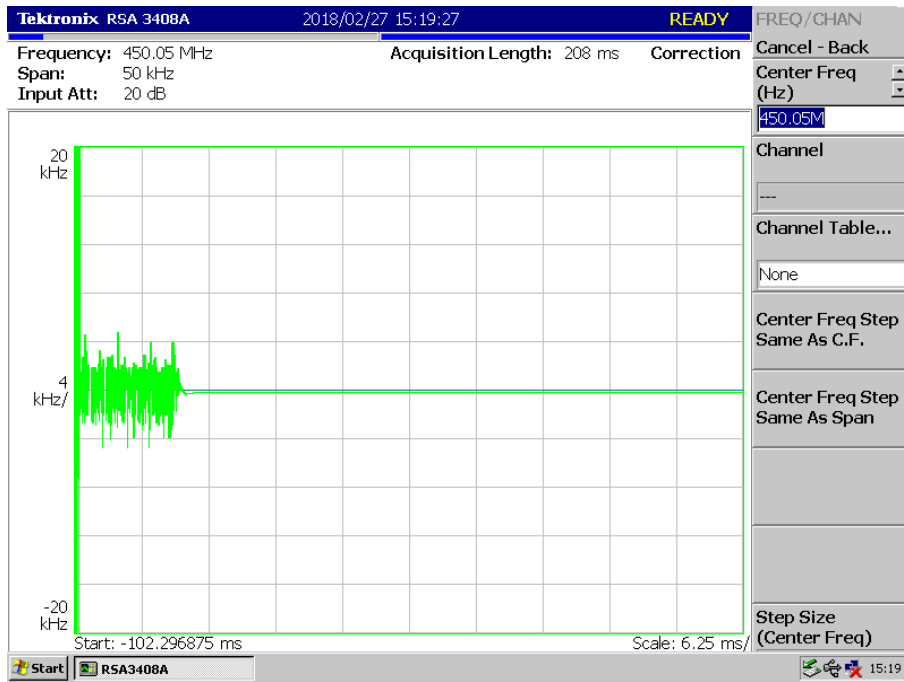

(16K0F3E _ 460.05 MHz)_High

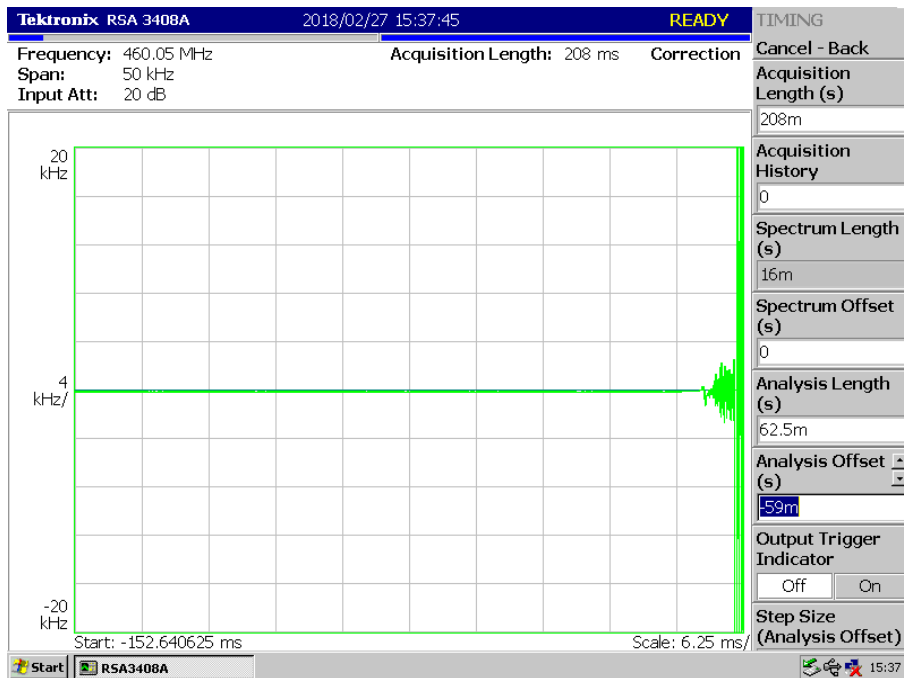
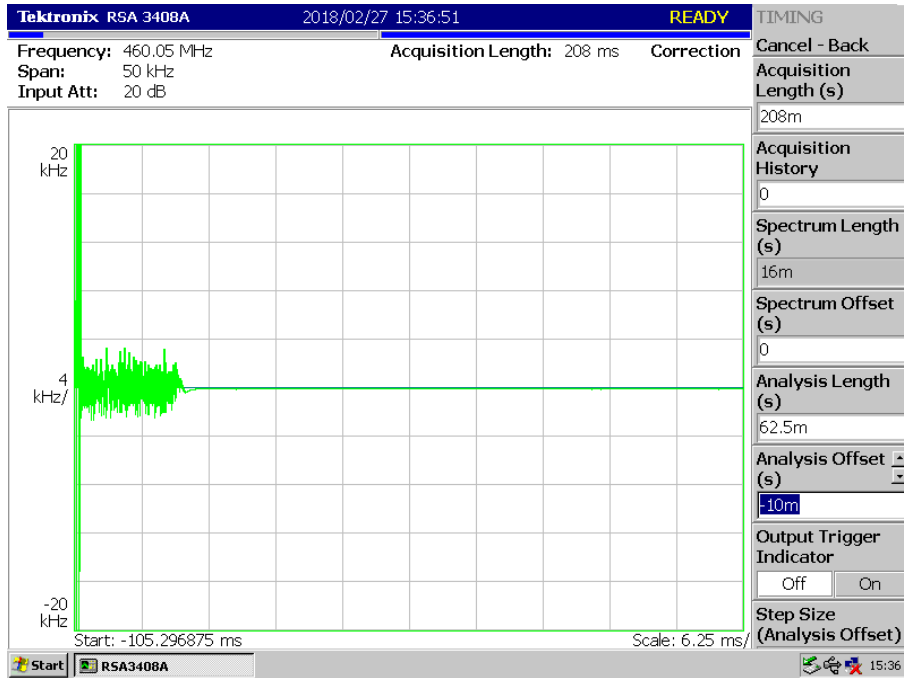

(16K0F3E _ 469.95 MHz)_High

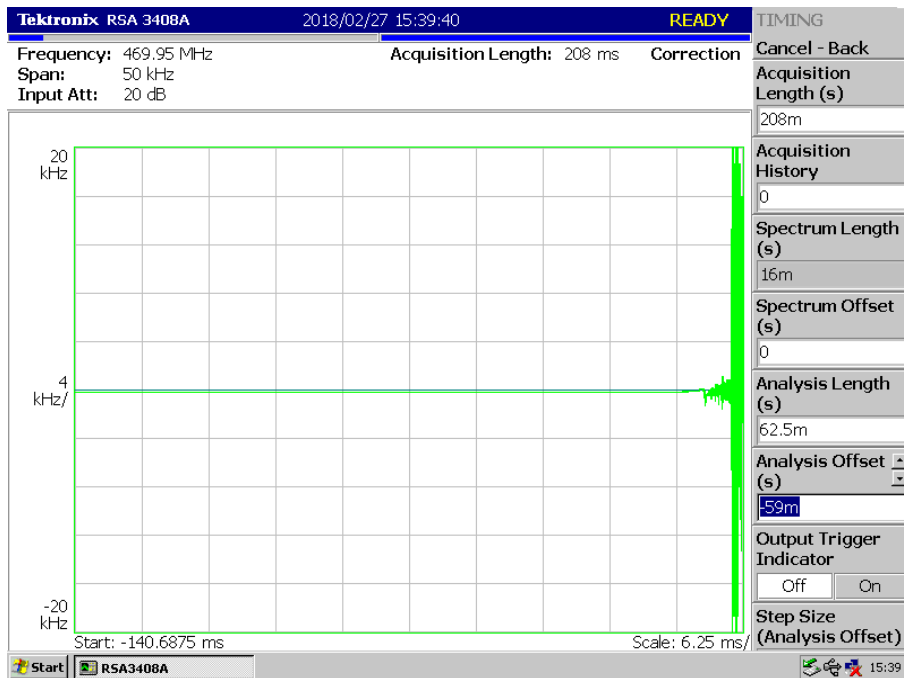
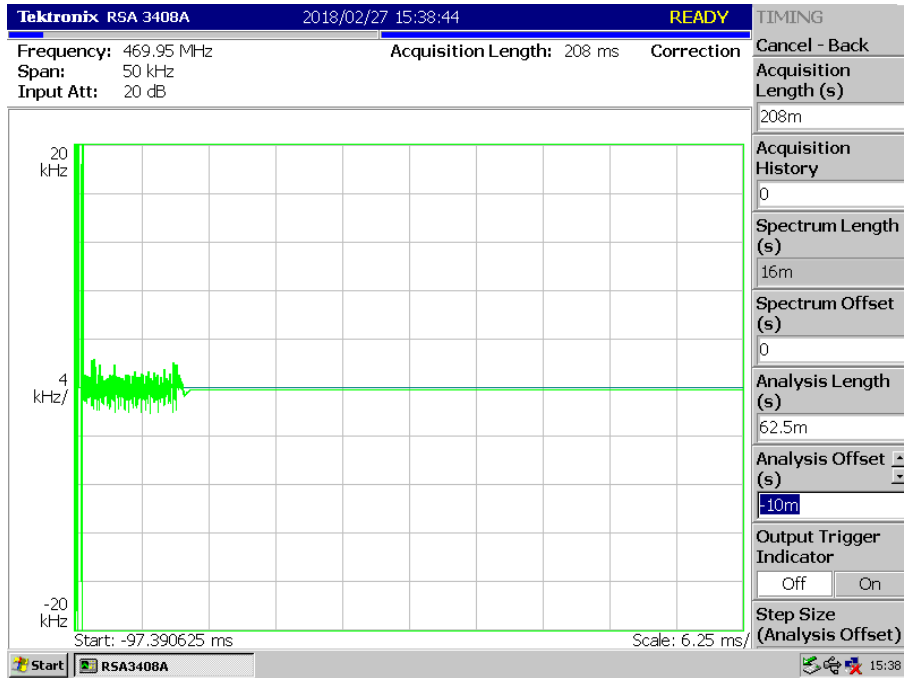

(16K0F3E _ 450.05 MHz)_Low

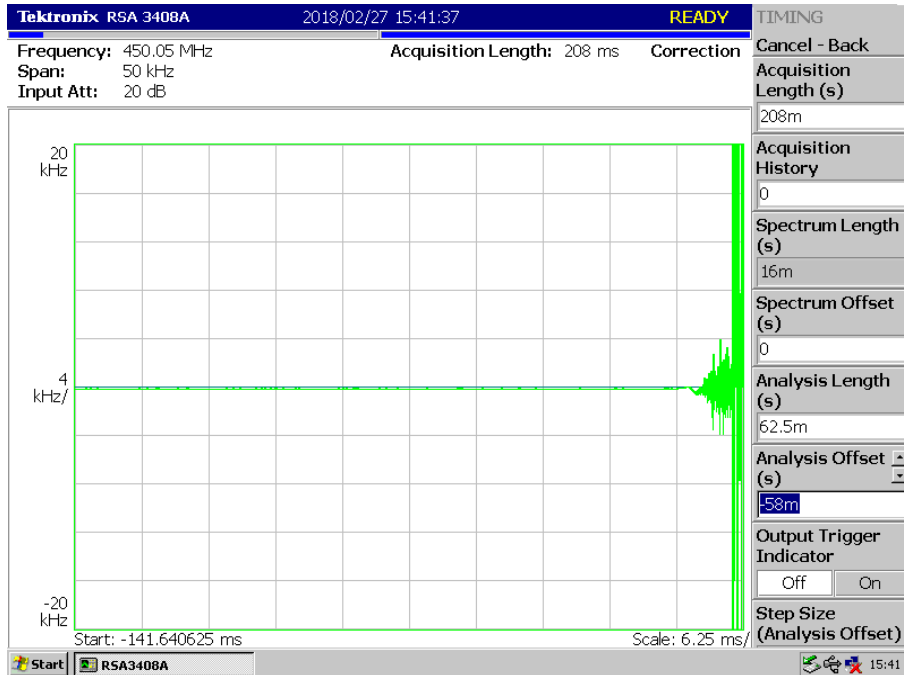
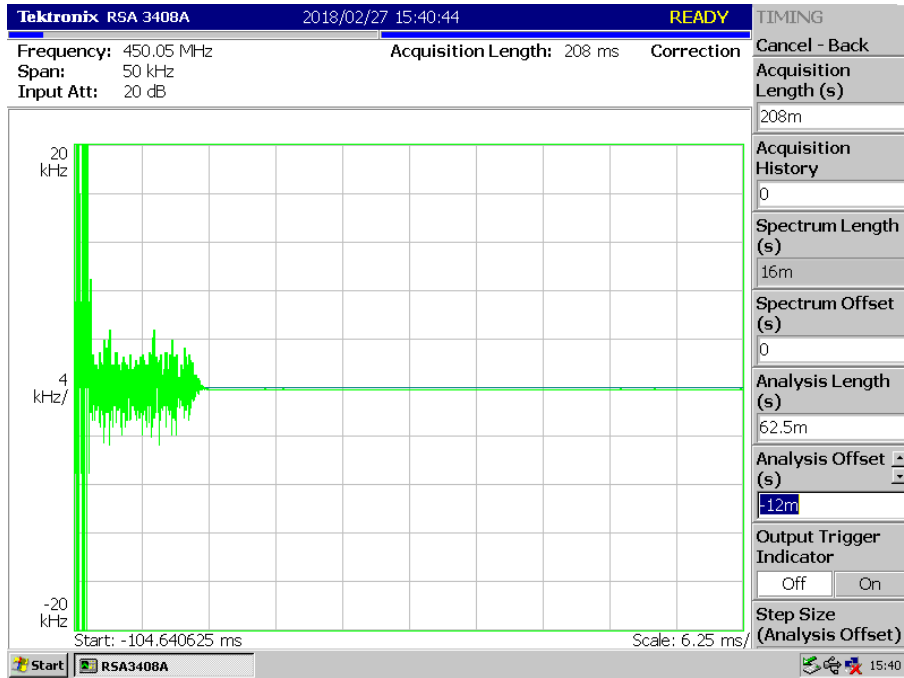

(16K0F3E _ 460.05 MHz)_Low

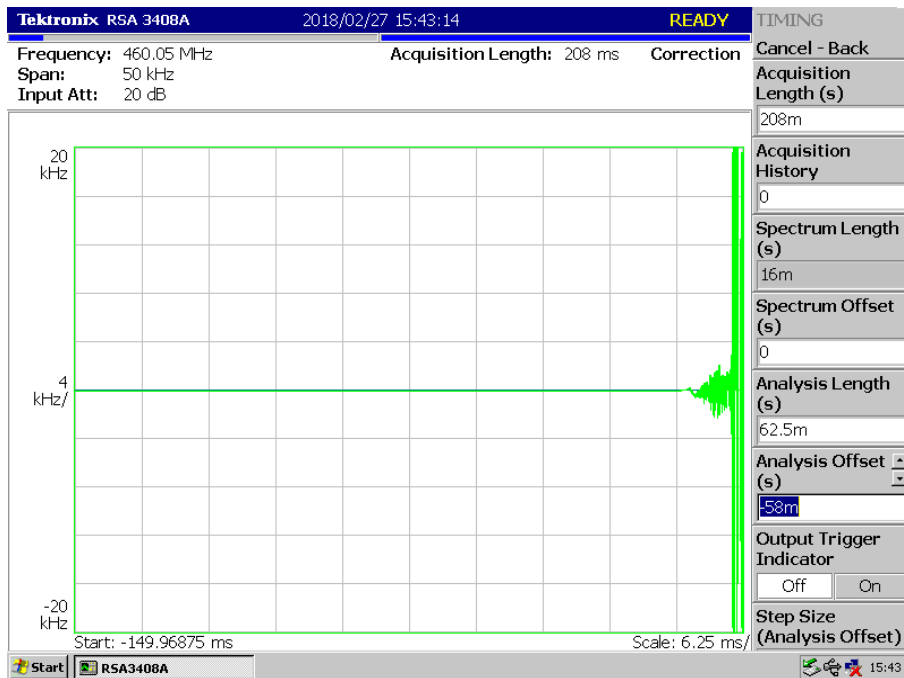
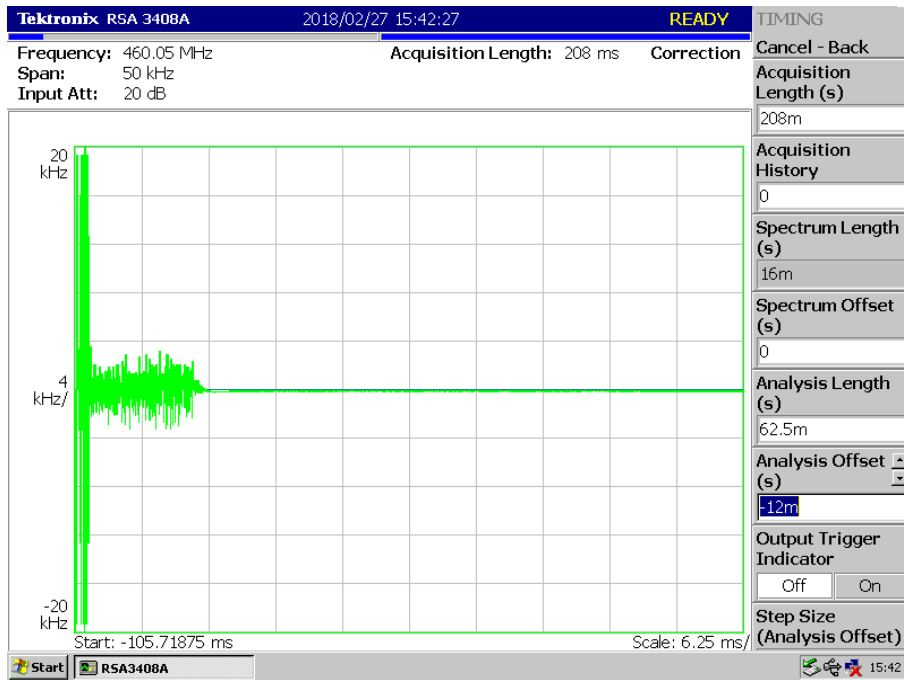

(16K0F3E _ 469.95 MHz)_Low

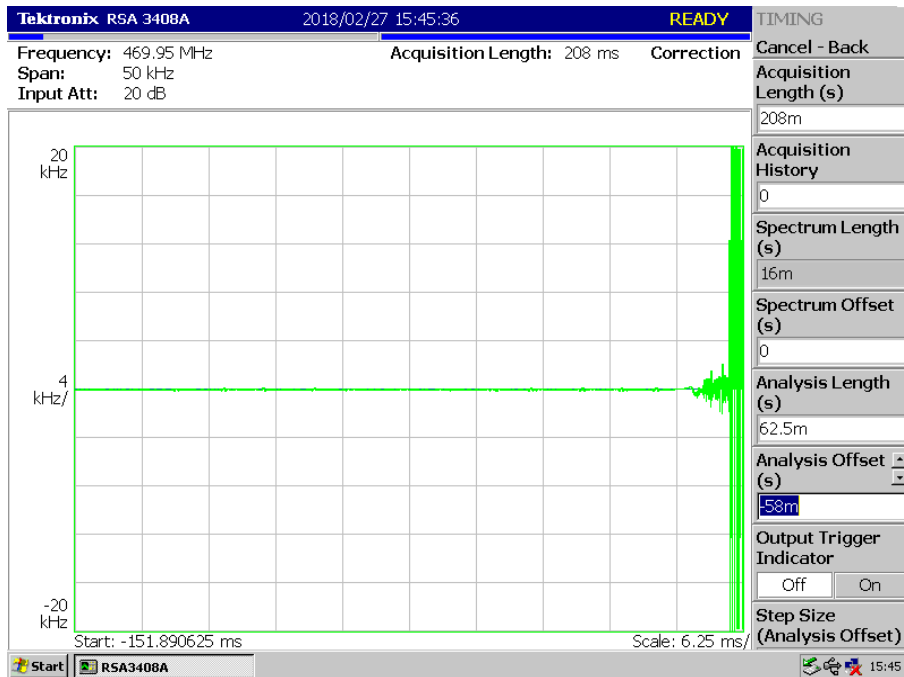
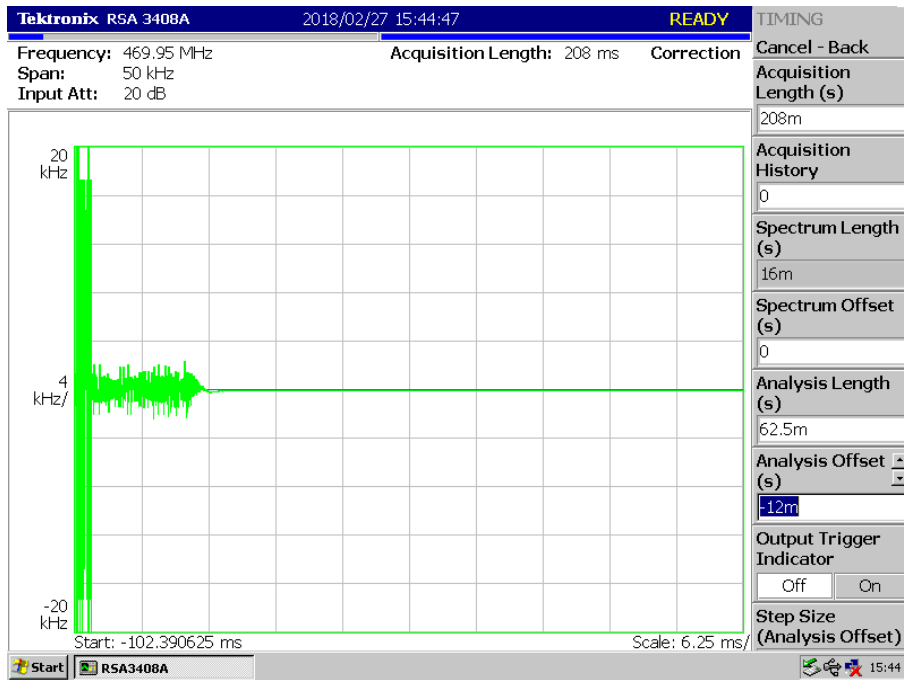

7.9 Unwanted Emissions : Conducted Spurious Emission

■ Definition

Conducted spurious emissions are emissions at the antenna terminals on a frequency or frequencies that are outside a band sufficient to ensure transmission of information of required quality for the class of communication desired.

■ TEST CONFIGURATION

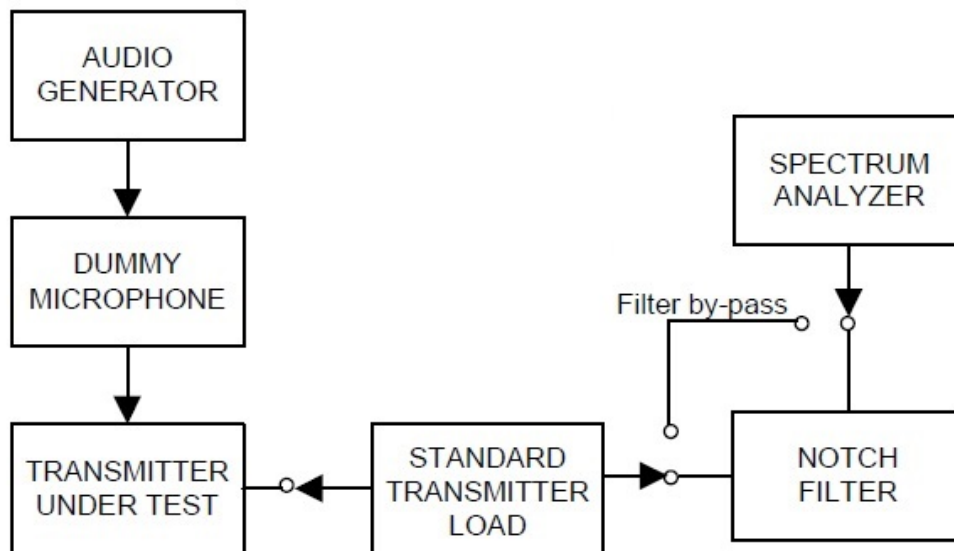

■ TEST PROCEDURE

According to 2.2.13 in TIA-603-E Standard.

- e) Connect the equipment as illustrated, with the notch filter by-passed.
- f) Set the center frequency of the spectrum analyzer to the assigned transmitter frequency, key the transmitter, and set the level of the carrier to the full scale reference line.
- g) Modulate the transmitter with a 2500 Hz sine wave at an input level 16 dB greater than that necessary to produce 50% of rated system deviation. The input level shall be established at the frequency of maximum response of the audio modulation circuit.
- h) Adjust the spectrum analyzer for the following settings:
 - 1) Resolution Bandwidth = 10 kHz for spurious emissions below 1 GHz, and 1 MHz for spurious emissions above 1 GHz.
 - 2) Video Bandwidth ≥ 3 times the resolution bandwidth.
 - 3) Sweep Speed ≤ 2000 Hz per second.
 - 4) Detector Mode = mean or average power.
- e) Adjust the center frequency of the spectrum analyzer for incremental coverage of the range from:
 - 1) The lowest radio frequency generated in the equipment to the carrier frequency minus the test bandwidth (see 1.3.4.4).

- 2) The carrier frequency plus the test bandwidth to a frequency less than 2 times the carrier frequency.
- f) Record the frequencies and levels of spurious emissions from step e).
- g) Unkey the transmitter. Replace the transmitter under test with the signal generator and adjust the signal level to reproduce the frequencies and levels of every spurious emission recorded in step f). Record the signal generator levels in dBm.
- h) Insert the notch filter.
- i) Adjust the spectrum analyzer for the following settings:
 - 1) Resolution Bandwidth = 10 kHz for spurious emissions below 1 GHz, and 1 MHz for spurious emissions above 1 GHz.
 - 2) Video Bandwidth ≥ 3 times the resolution bandwidth.
 - 3) Sweep Speed ≤ 2000 Hz per second.
 - 4) Detector Mode = mean or average power.
- j) Key the transmitter. Adjust the center frequency of the spectrum analyzer for incremental coverage of the range from a frequency equal to 2 times the carrier frequency and to the tenth harmonic of the carrier frequency.

▣ **LIMIT**

Frequency Band (MHz)	Channel bandwidth (kHz)	Limit (dB)
450-470	12.5	50+10Log(P) or 70 dB
	6.25	55+10Log(P) or 65 dB
	25	43+10Log(p)

Note

1. Correct Level (dBm) : Substitute SG Level (dBm)
2. Emission Level (dBc) : Correct Level – 10Log(P*1000)
3. P = Carrier Output Power(W)
(P value, please refer to Section 7.1)

■ **TEST RESULTS**

11K0F3E

No.	Frequency (MHz)	Band	Setting	Spurious Frequency (MHz)	Correct Level (dBm)	Emission Level (dBc)	Limit (dBc)	Margin (dB)
1	450.05	Low	High Power	0.13	-73.194	-106.354	-53.160	53.194
				3.55	-64.359	-97.519	-53.160	44.359
				900.09	-35.973	-69.133	-53.160	15.973
				3625.79	-37.840	-71.000	-53.160	17.840
2	460.05	Middle		0.13	-71.768	-105.057	-53.289	51.768
				2.07	-64.670	-97.959	-53.289	44.670
				920.46	-37.425	-70.714	-53.289	17.425
				3171.24	-38.222	-71.511	-53.289	18.222
3	469.95	High		0.13	-70.276	-103.246	-52.970	50.276
				25.20	-64.741	-97.711	-52.970	44.741
				939.86	-36.750	-69.720	-52.970	16.750
				3649.79	-38.696	-71.666	-52.970	18.696
4	450.05	Low	0.12	-71.484	-101.653	-50.169	51.484	
			22.21	-63.728	-93.897	-50.169	43.728	
			900.09	-36.120	-66.289	-50.169	16.120	
			3659.80	-38.635	-68.804	-50.169	18.635	
5	460.05	Middle	0.01	-72.843	-103.175	-50.332	52.843	
			17.07	-64.859	-95.191	-50.332	44.859	
			920.46	-37.259	-67.591	-50.332	17.259	
			3675.30	-38.863	-69.195	-50.332	18.863	
6	469.95	High	0.12	-71.732	-101.930	-50.198	51.732	
			3.89	-64.816	-95.014	-50.198	44.816	
			939.86	-37.013	-67.211	-50.198	17.013	
			3734.30	-39.030	-69.228	-50.198	19.030	

16K0F3E

No.	Frequency (MHz)	Band	Setting	Spurious Frequency (MHz)	Correct Level (dBm)	Emission Level (dBc)	Limit (dBc)	Margin (dB)
1	450.05	Low	High Power	0.13	-72.465	-105.732	-53.267	52.465
				3.38	-64.537	-97.804	-53.267	44.537
				900.09	-36.559	-69.826	-53.267	16.559
				3611.29	-38.703	-71.970	-53.267	18.703
2	460.05	Middle		0.12	-71.059	-104.295	-53.236	51.059
				5.62	-64.778	-98.014	-53.236	44.778
				920.46	-37.565	-70.801	-53.236	17.565
3	469.95	High		3651.79	-38.748	-71.984	-53.236	18.748
				0.13	-73.422	-106.329	-52.907	53.422
				25.19	-64.325	-97.232	-52.907	44.325
				939.86	-36.664	-69.571	-52.907	16.664
4	450.05	Low		3699.80	-38.574	-71.481	-52.907	18.574
			0.13	-72.363	-102.466	-50.103	52.363	
			20.99	-64.720	-94.823	-50.103	44.720	
			900.09	-36.087	-66.190	-50.103	16.087	
5	460.05	Middle	3602.79	-37.714	-67.817	-50.103	17.714	
			0.13	-71.760	-102.069	-50.309	51.760	
			19.99	-65.059	-95.368	-50.309	45.059	
			920.46	-37.677	-67.986	-50.309	17.677	
6	469.95	High	3043.73	-38.998	-69.307	-50.309	18.998	
			0.03	-72.921	-103.194	-50.273	52.921	
			29.26	-64.920	-95.193	-50.273	44.920	
			939.86	-37.655	-67.928	-50.273	17.655	
			3652.29	-38.405	-68.678	-50.273	18.405	

8K30F1E, 8K30F1D, 8K30F7W

No.	Frequency (MHz)	Band	Setting	Spurious Frequency (MHz)	Correct Level (dBm)	Emission Level (dBc)	Limit (dBc)	Margin (dB)
1	450.05	Low	High Power	0.13	-72.169	-105.429	-53.260	52.169
				16.61	-64.633	-97.893	-53.260	44.633
				900.09	-36.143	-69.403	-53.260	16.143
				3096.23	-38.997	-72.257	-53.260	18.997
2	460.05	Middle		0.13	-71.029	-104.299	-53.270	51.029
				3.38	-63.996	-97.266	-53.270	43.996
				920.46	-36.995	-70.265	-53.270	16.995
				3175.24	-38.325	-71.595	-53.270	18.325
3	469.95	High		0.13	-71.592	-104.542	-52.950	51.592
				25.20	-64.849	-97.799	-52.950	44.849
				939.86	-36.877	-69.827	-52.950	16.877
				4979.94	-38.930	-71.880	-52.950	18.930
4	450.05	Low	0.13	-71.640	-101.898	-50.258	51.640	
			25.20	-64.648	-94.906	-50.258	44.648	
			900.09	-35.974	-66.232	-50.258	15.974	
			2712.69	-38.653	-68.911	-50.258	18.653	
5	460.05	Middle	0.13	-72.380	-102.708	-50.328	52.380	
			28.50	-64.836	-95.164	-50.328	44.836	
			920.46	-37.352	-67.680	-50.328	17.352	
			3791.81	-38.174	-68.502	-50.328	18.174	
6	469.95	High	0.13	-70.442	-100.568	-50.126	50.442	
			1.18	-64.629	-94.755	-50.126	44.629	
			939.86	-37.354	-67.480	-50.126	17.354	
			3615.79	-38.236	-68.362	-50.126	18.236	

4K00F1E, 4K00F1D, 4K00F7W

No.	Frequency (MHz)	Band	Setting	Spurious Frequency (MHz)	Correct Level (dBm)	Emission Level (dBc)	Limit (dBc)	Margin (dB)
1	450.05	Low	High Power	0.12	-72.007	-105.230	-53.223	52.007
				26.52	-64.813	-98.036	-53.223	44.813
				900.09	-36.442	-69.665	-53.223	16.442
				3620.79	-38.887	-72.110	-53.223	18.887
2	460.05	Middle		0.13	-72.157	-105.173	-53.016	52.157
				23.01	-64.941	-97.957	-53.016	44.941
				920.46	-37.567	-70.583	-53.016	17.567
3	469.95	High		3641.29	-37.741	-70.757	-53.016	17.741
				0.12	-72.055	-104.945	-52.890	52.055
				14.23	-65.137	-98.027	-52.890	45.137
4	450.05	Low		939.86	-37.043	-69.933	-52.890	17.043
				3656.30	-38.727	-71.617	-52.890	18.727
			0.13	-71.024	-101.032	-50.008	51.024	
			22.58	-64.873	-94.881	-50.008	44.873	
5	460.05	Middle	900.09	-36.171	-66.179	-50.008	16.171	
			3030.23	-37.968	-67.976	-50.008	17.968	
			0.13	-72.809	-102.871	-50.062	52.809	
			25.34	-64.417	-94.479	-50.062	44.417	
6	469.95	High	920.46	-37.689	-67.751	-50.062	17.689	
			3660.30	-38.589	-68.651	-50.062	18.589	
			0.13	-72.479	-102.477	-49.998	52.479	
			20.65	-64.100	-94.098	-49.998	44.100	
			939.86	-37.302	-67.300	-49.998	17.302	
			3625.79	-38.472	-68.470	-49.998	18.472	

4K00F2D

No.	Frequency (MHz)	Band	Setting	Spurious Frequency (MHz)	Correct Level (dBm)	Emission Level (dBc)	Limit (dBc)	Margin (dB)
1	450.05	Low	High Power	0.13	-72.019	-104.976	-52.957	52.019
				7.98	-65.534	-98.491	-52.957	45.534
				900.09	-37.331	-70.288	-52.957	17.331
				3585.29	-39.145	-72.102	-52.957	19.145
2	460.05	Middle		0.13	-73.177	-106.087	-52.910	53.177
				10.50	-65.500	-98.410	-52.910	45.500
				920.46	-37.718	-70.628	-52.910	17.718
				3649.29	-39.401	-72.311	-52.910	19.401
3	469.95	High		0.13	-72.572	-105.074	-52.502	52.572
				27.56	-64.281	-96.783	-52.502	44.281
				939.86	-36.786	-69.288	-52.502	16.786
				3197.74	-38.498	-71.000	-52.502	18.498
1	450.05	Low	Low Power	0.12	-71.523	-101.806	-50.283	51.523
				25.20	-63.512	-93.795	-50.283	43.512
				900.09	-36.269	-66.552	-50.283	16.269
				3073.23	-38.346	-68.629	-50.283	18.346
2	460.05	Middle		0.13	-69.643	-99.735	-50.092	49.643
				4.94	-65.309	-95.401	-50.092	45.309
				920.46	-37.369	-67.461	-50.092	17.369
				3625.79	-38.810	-68.902	-50.092	18.810
3	469.95	High		0.13	-72.059	-103.280	-51.221	52.059
				25.72	-64.534	-95.755	-51.221	44.534
				939.86	-37.499	-68.720	-51.221	17.499
				3622.79	-38.614	-69.835	-51.221	18.614

■ Plots of Unwanted Emissions : Conducted Spurious Emission FCC

11K0F3E _ 450.05 MHz_High

9 kHz~150 kHz

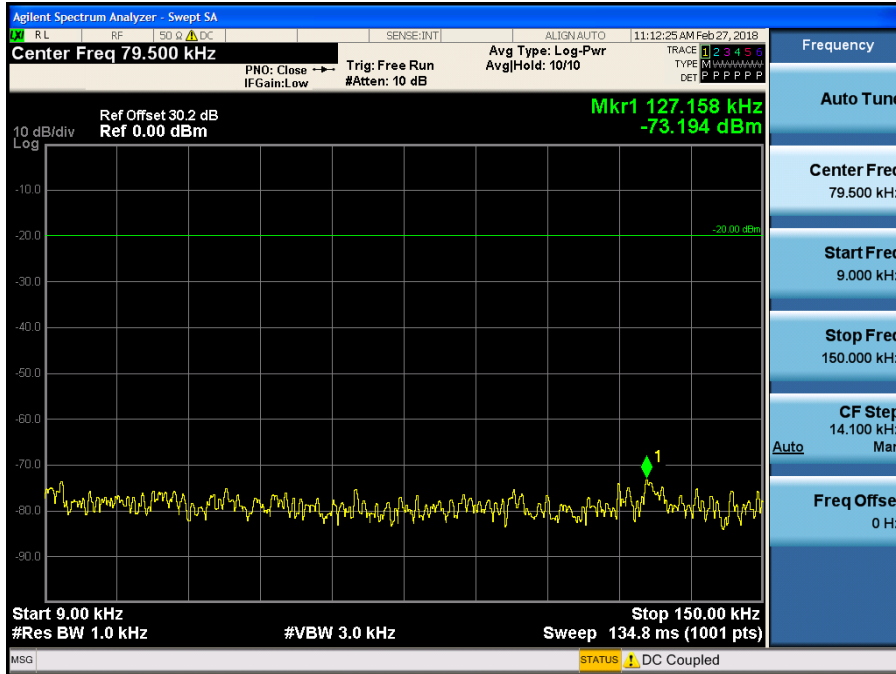

150 kHz~30 MHz

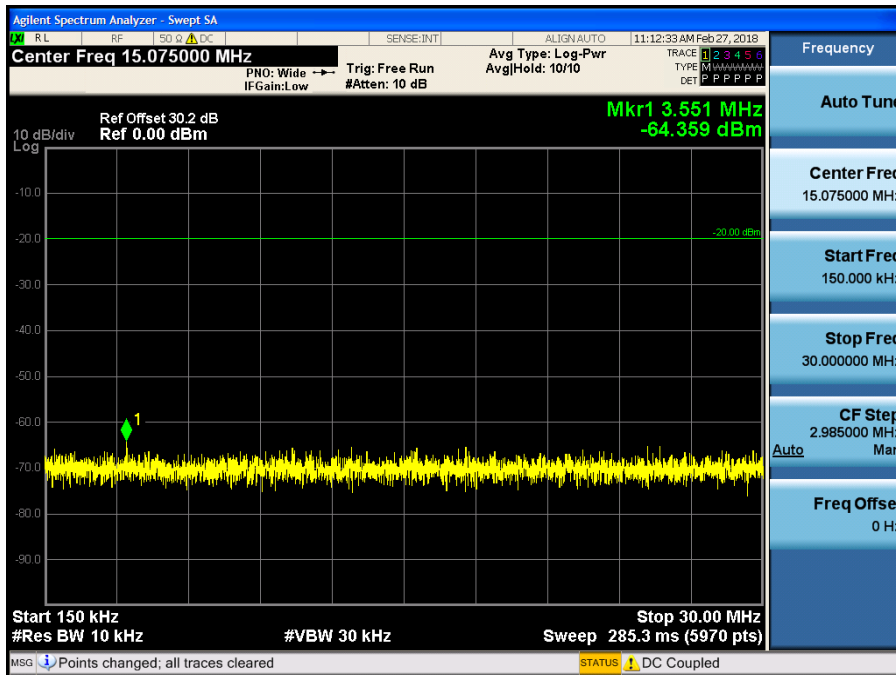

30 MHz~1 GHz

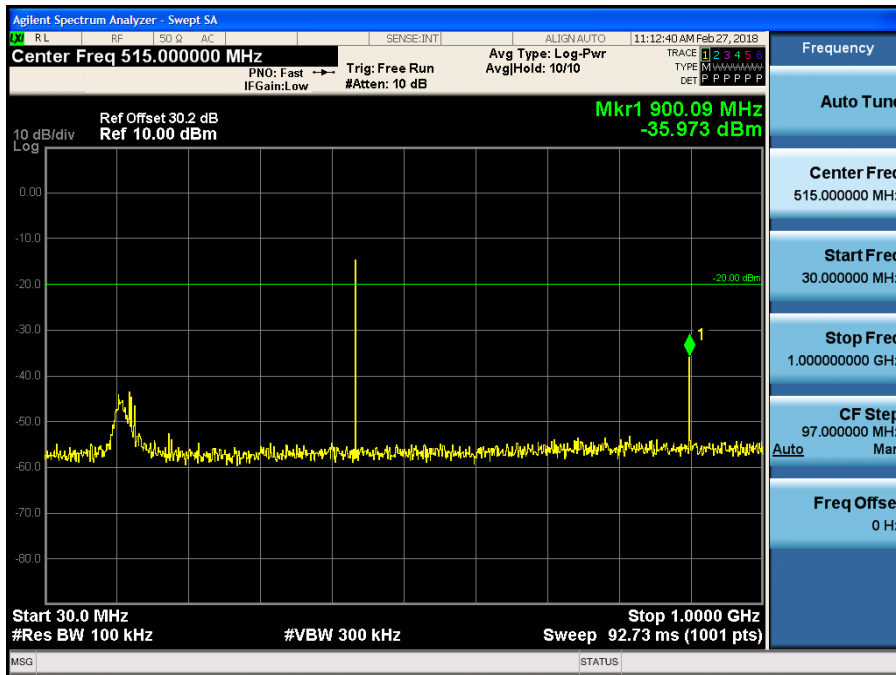

1 GHz~5.5 GHz

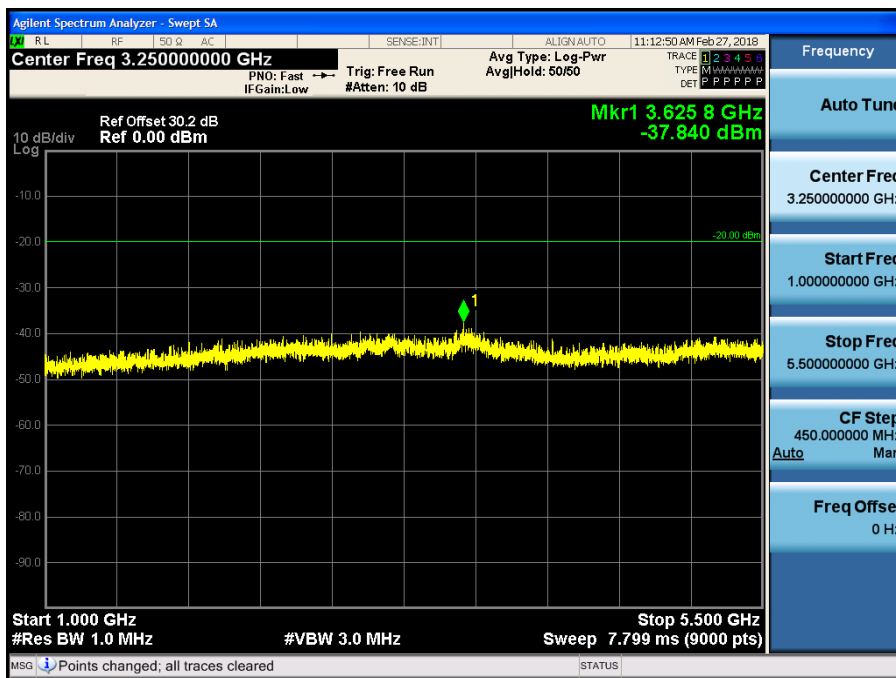

11K0F3E _ 460.05 MHz_High

9 kHz~150 kHz

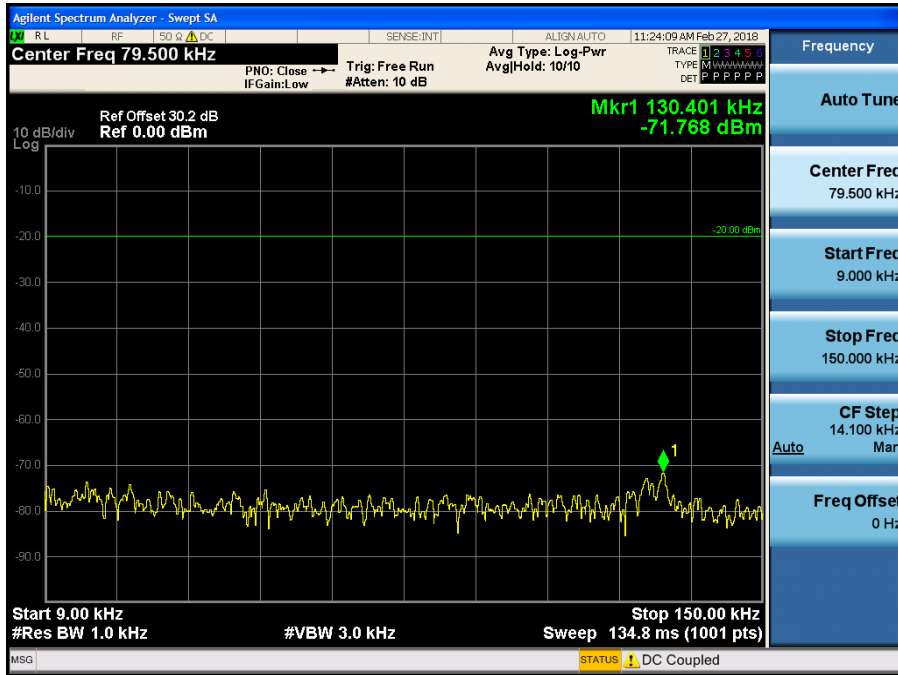

150 kHz~30 MHz

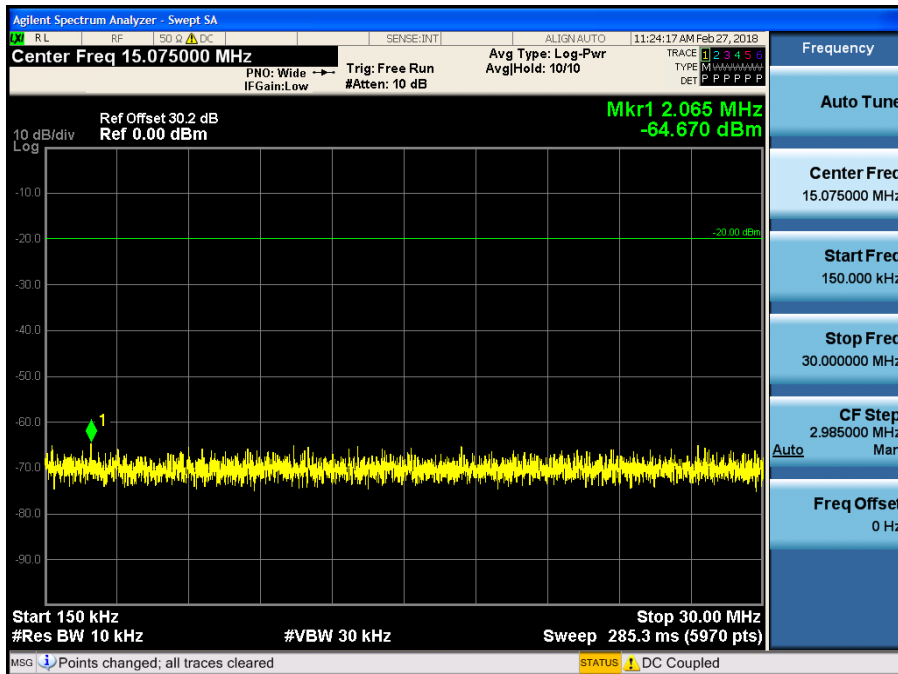

30 MHz~1 GHz

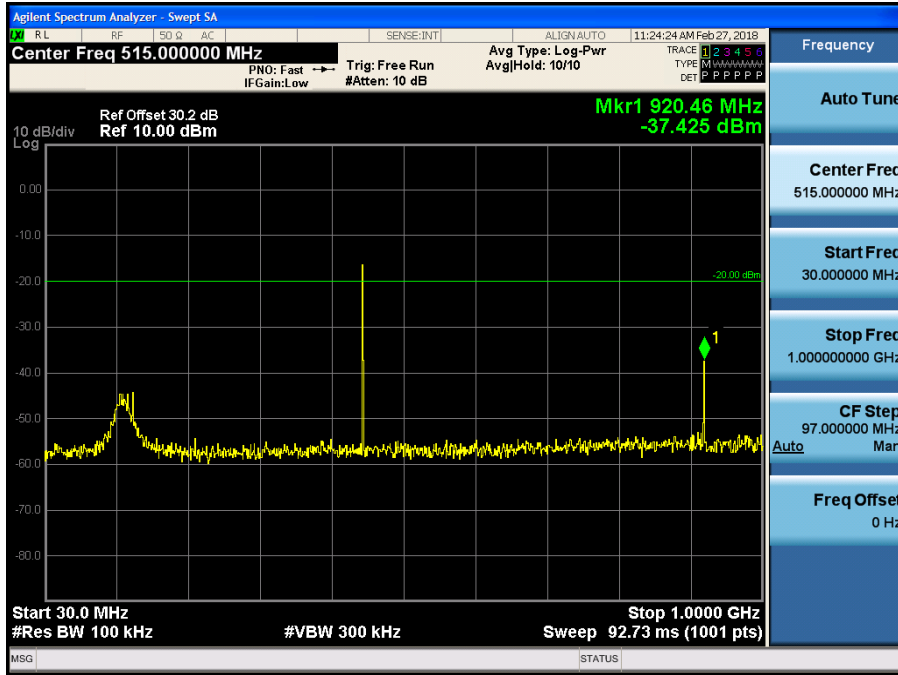

1 GHz~5.5 GHz

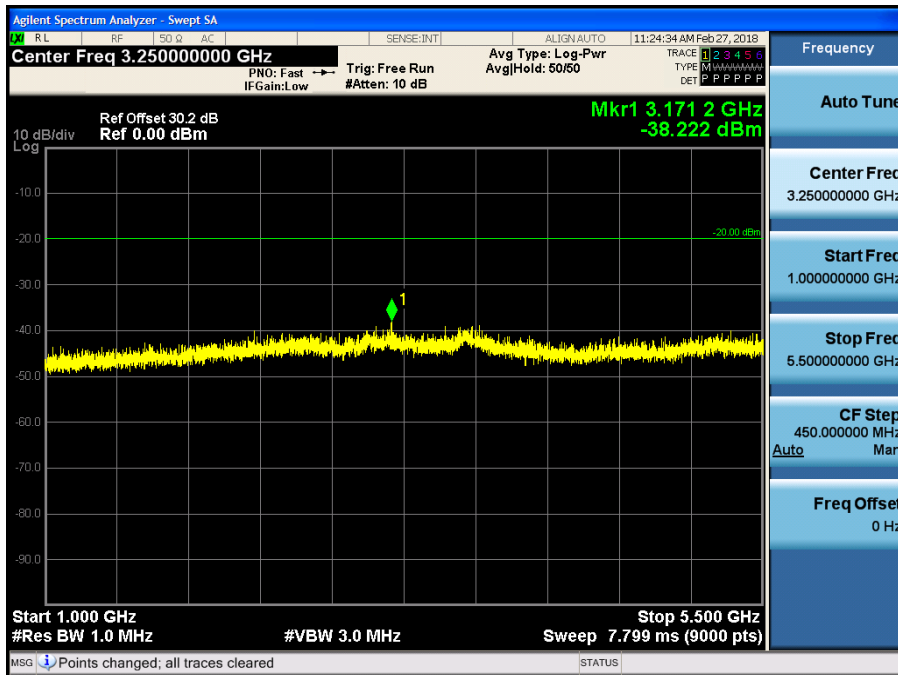

11K0F3E _ 469.95 MHz_High

9 kHz~150 kHz

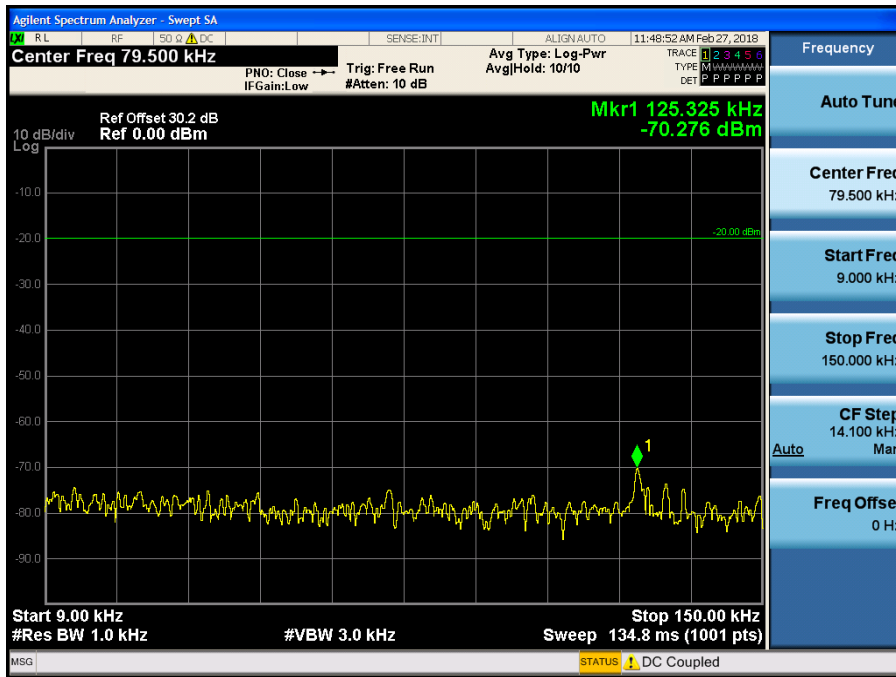

150 kHz~30 MHz

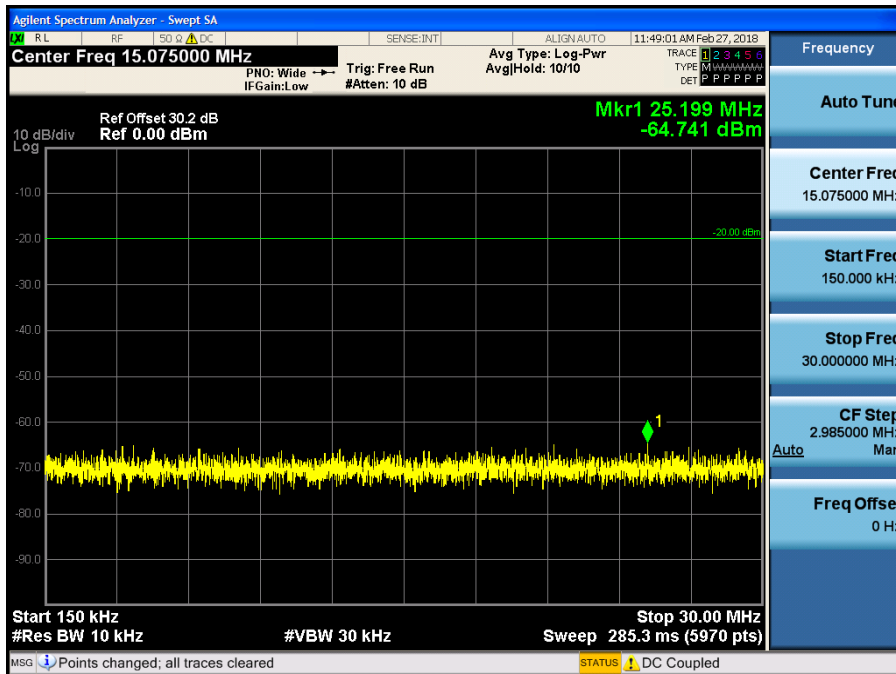

30 MHz~1 GHz

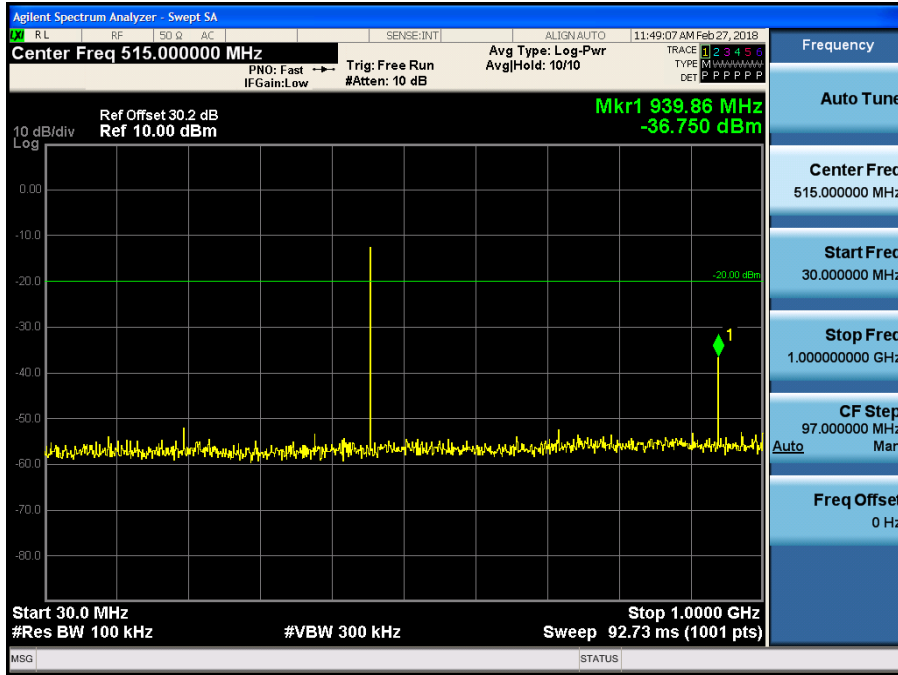

1 GHz~5.5 GHz

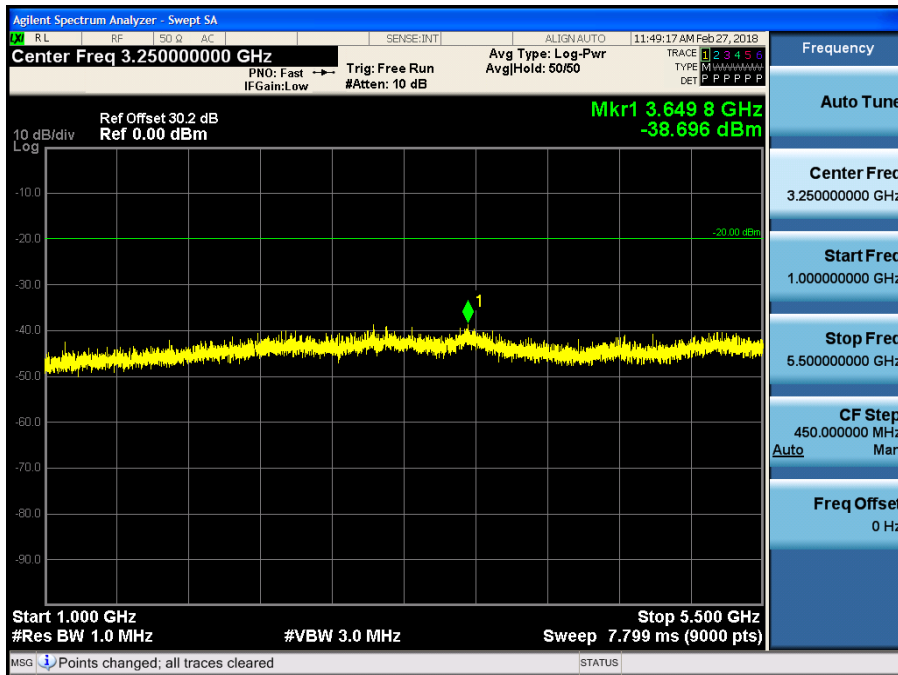

11K0F3E _ 450.05 MHz_Low

9 kHz~150 kHz

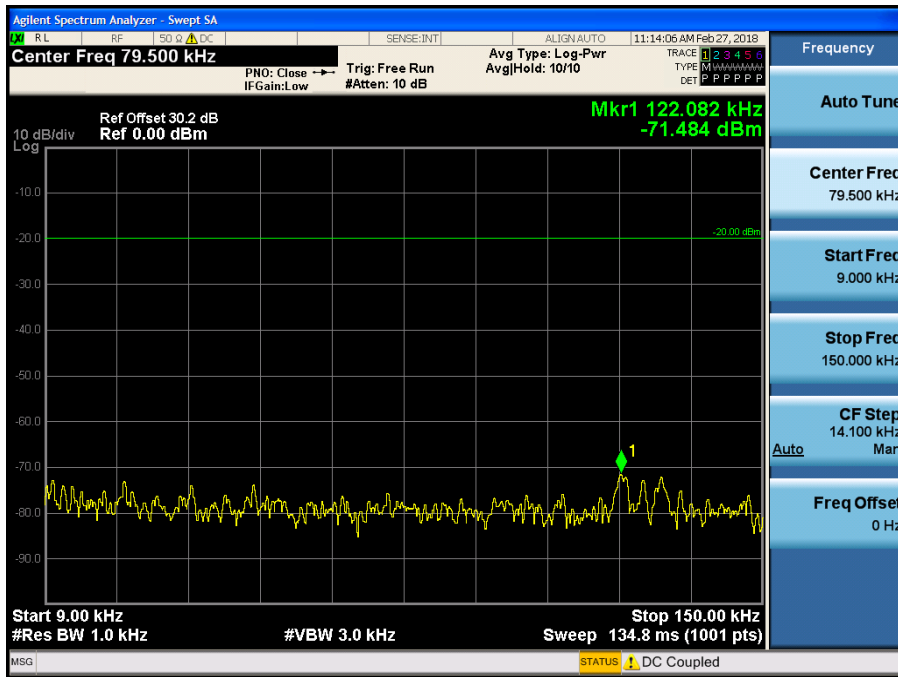

150 kHz~30 MHz

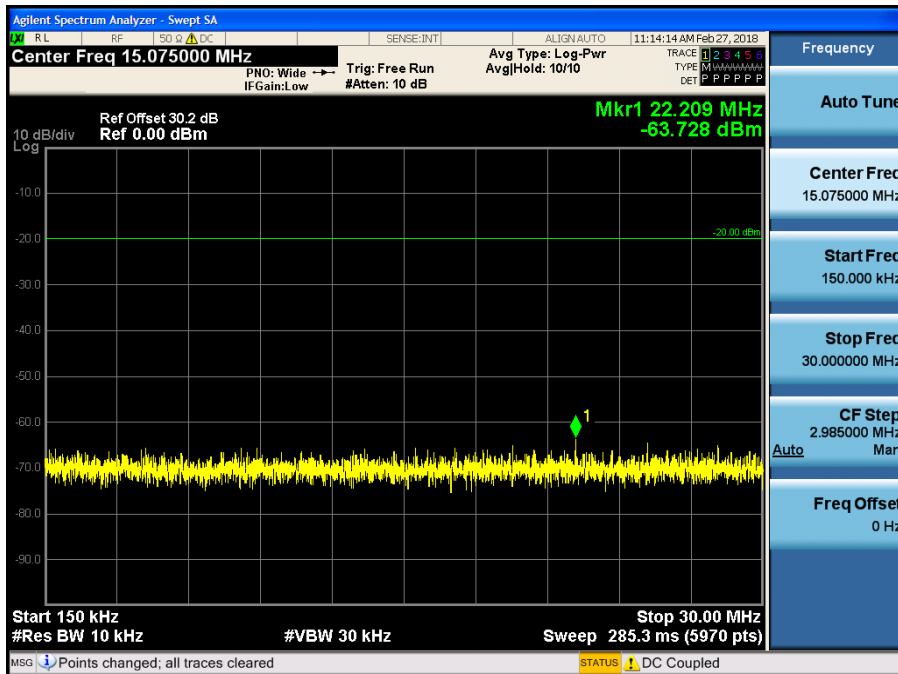

30 MHz~1 GHz

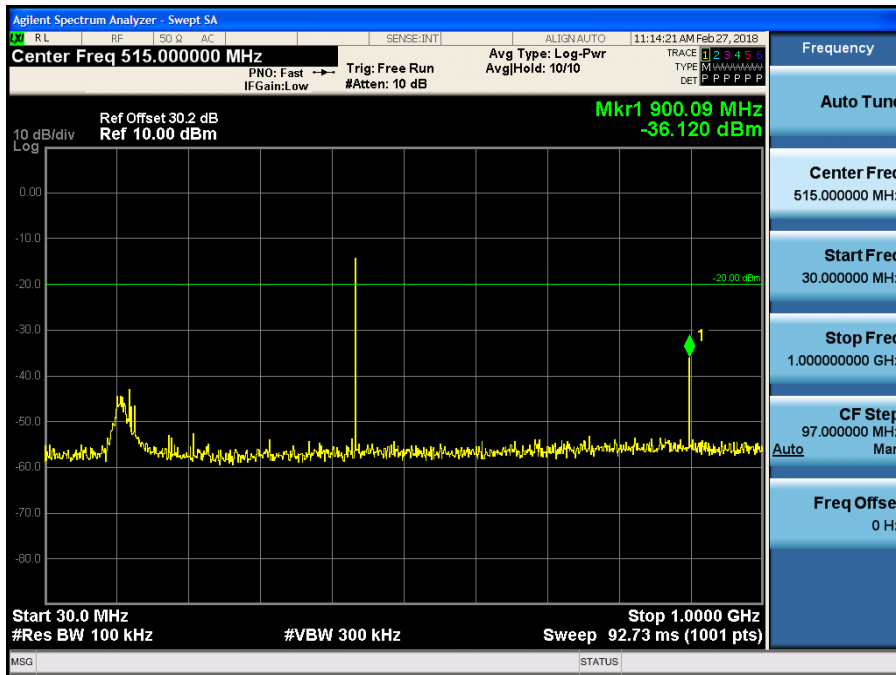

1 GHz~5.5 GHz

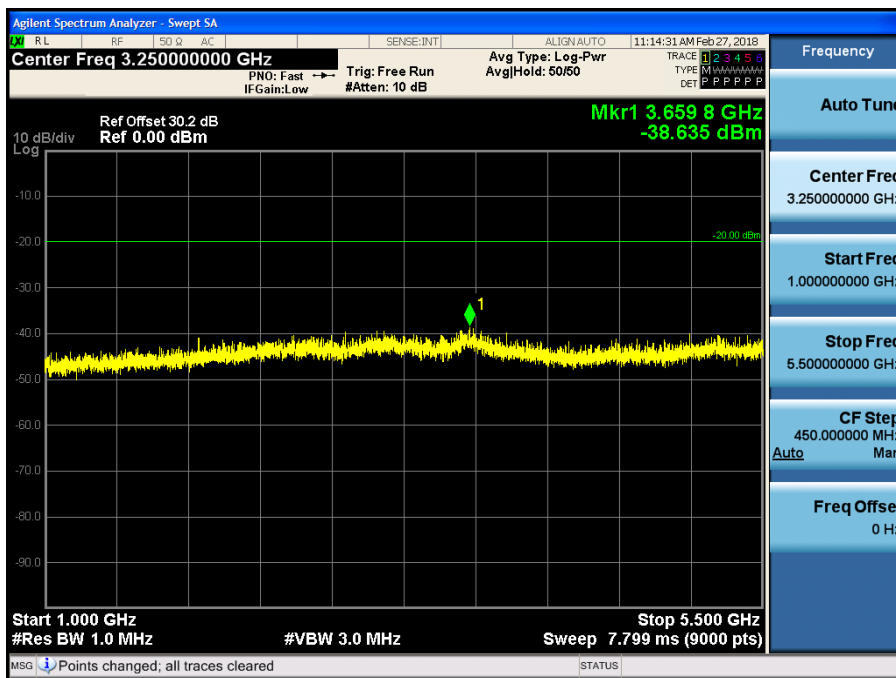

11K0F3E _ 460.05 MHz_Low

9 kHz~150 kHz

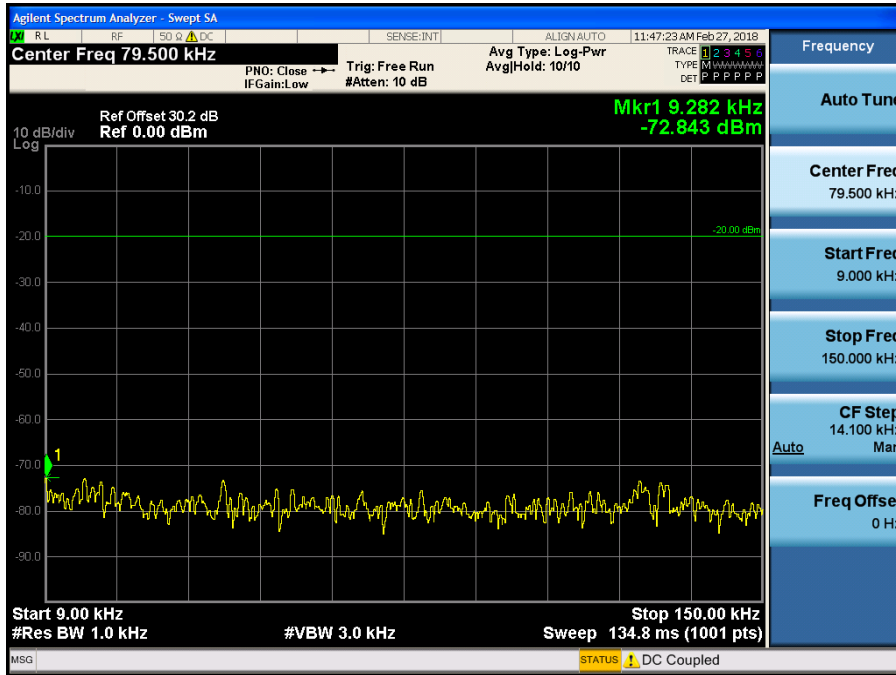

150 kHz~30 MHz

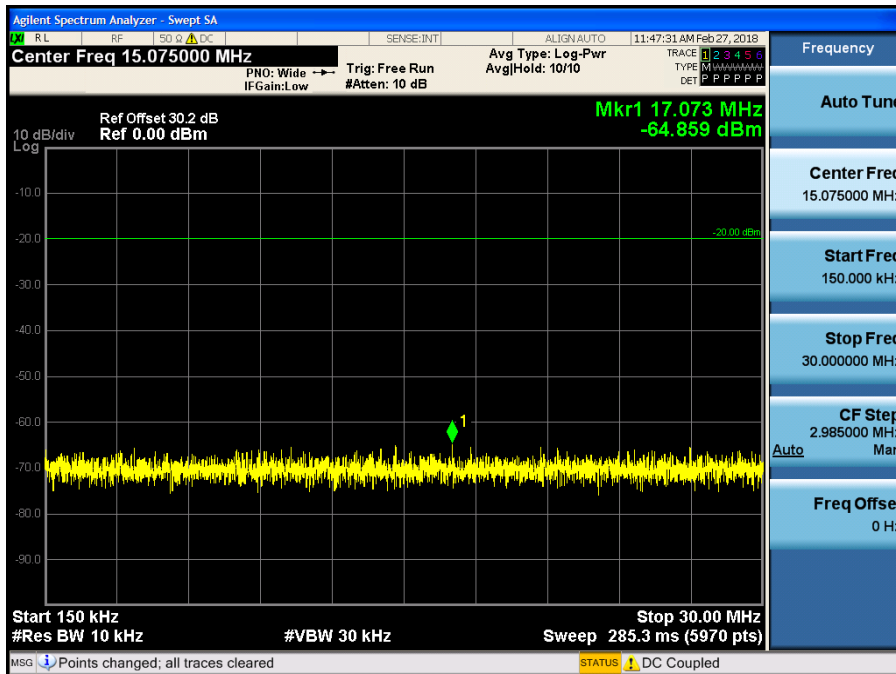

30 MHz~1 GHz

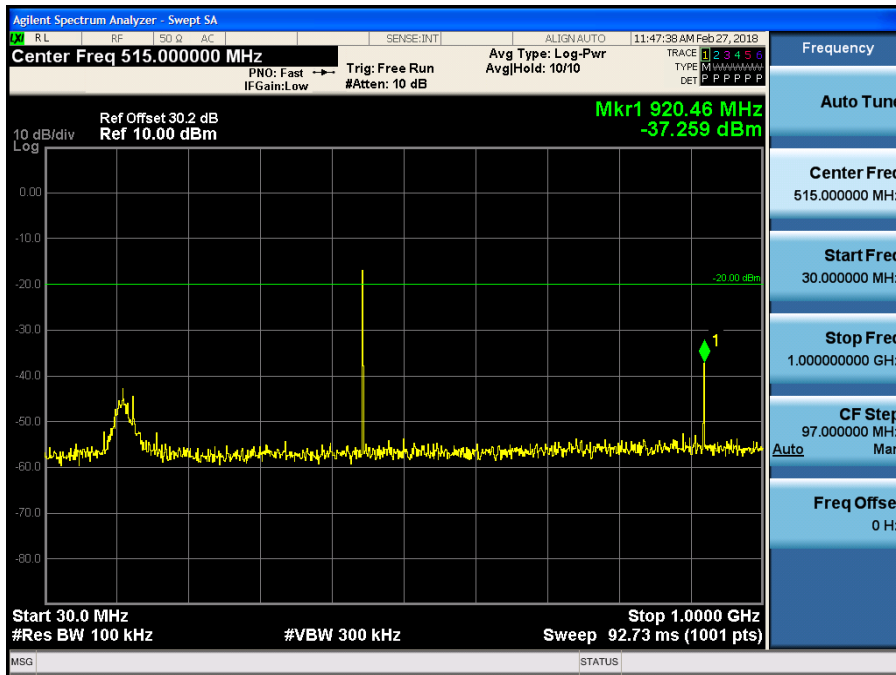

1 GHz~5.5 GHz

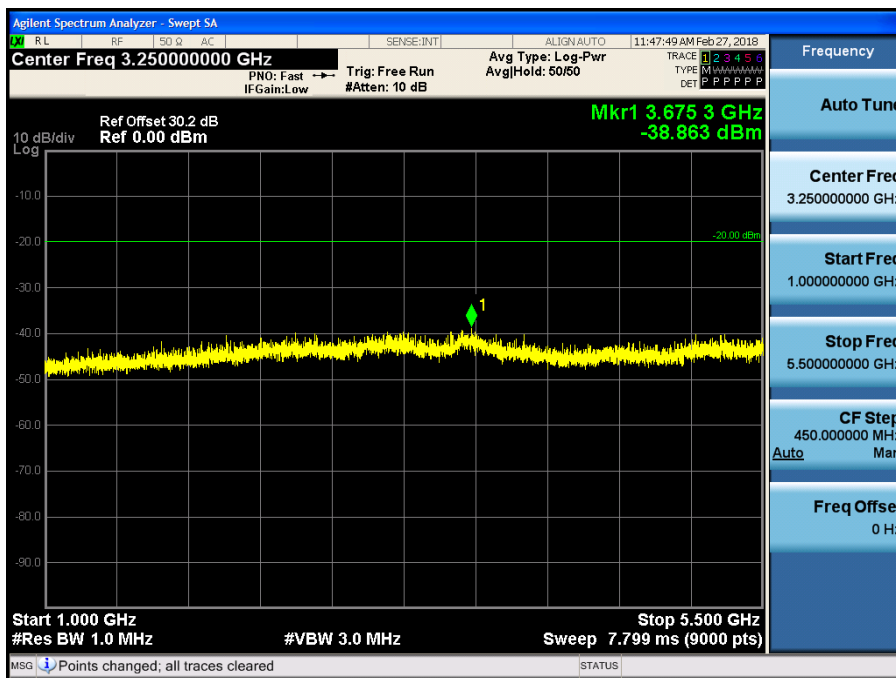

11K0F3E _ 469.95 MHz_Low

9 kHz~150 kHz

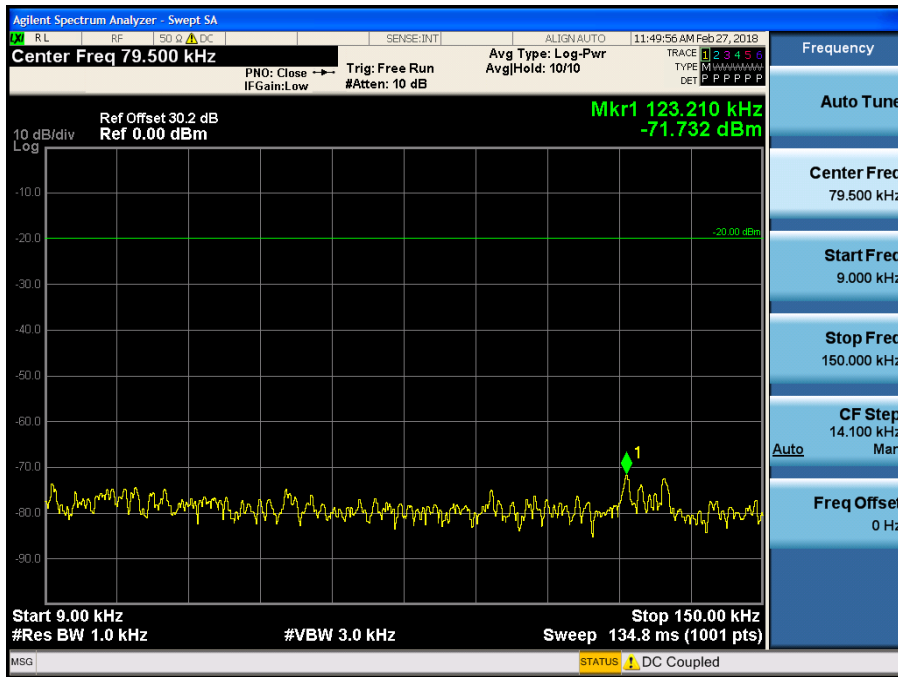

150 kHz~30 MHz

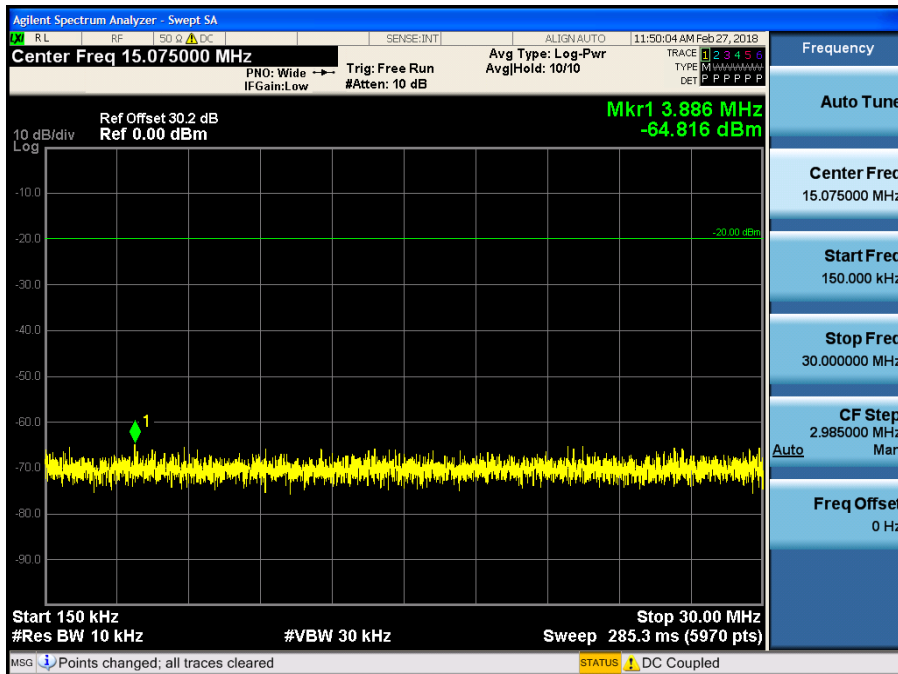

30 MHz~1 GHz

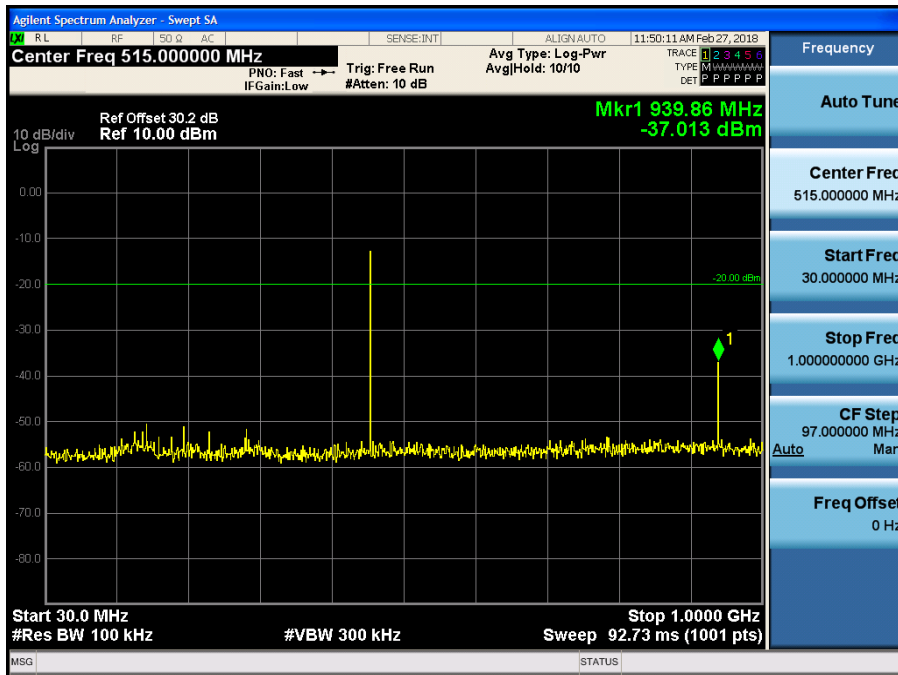

1 GHz~5.5 GHz

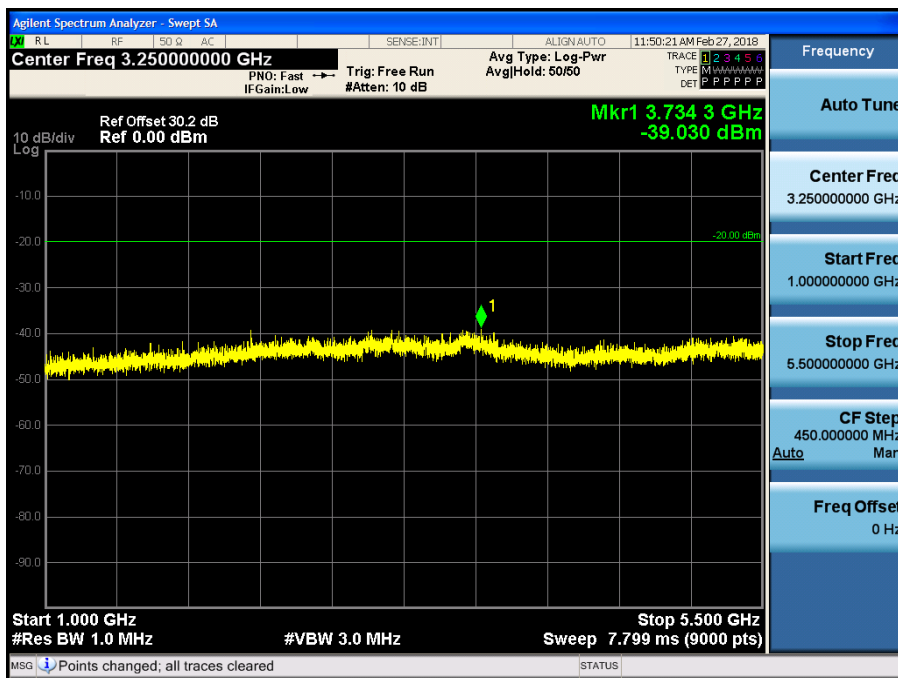

16K0F3E _ 450.05 MHz_High

9 kHz~150 kHz

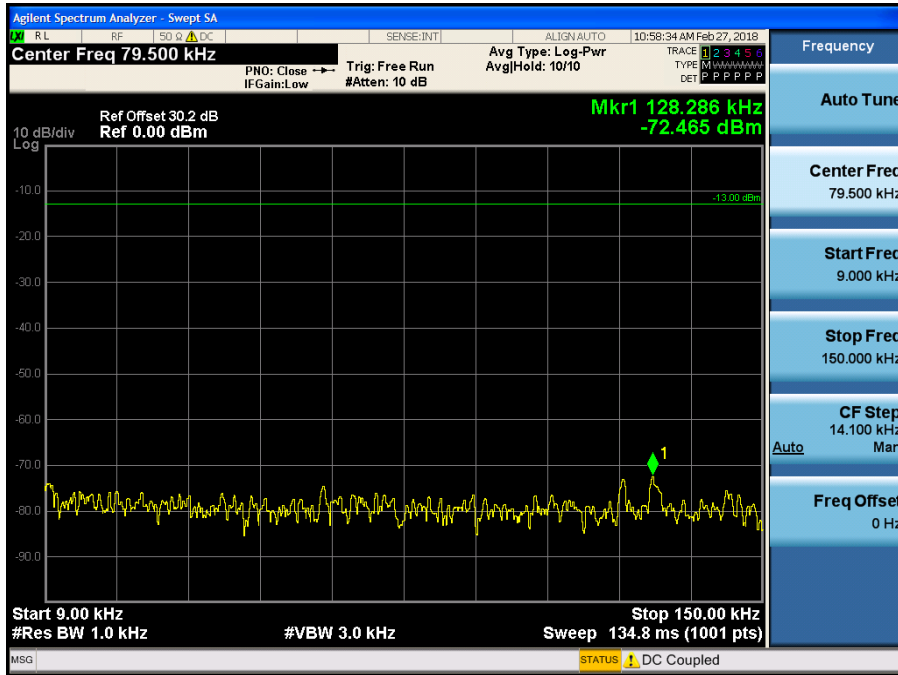

150 kHz~30 MHz

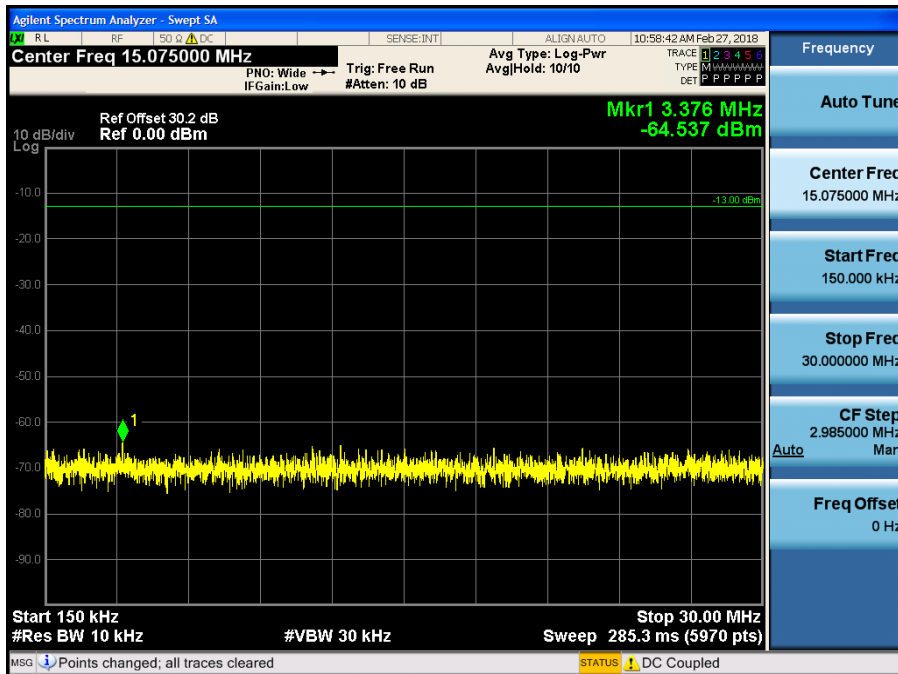

30 MHz~1 GHz

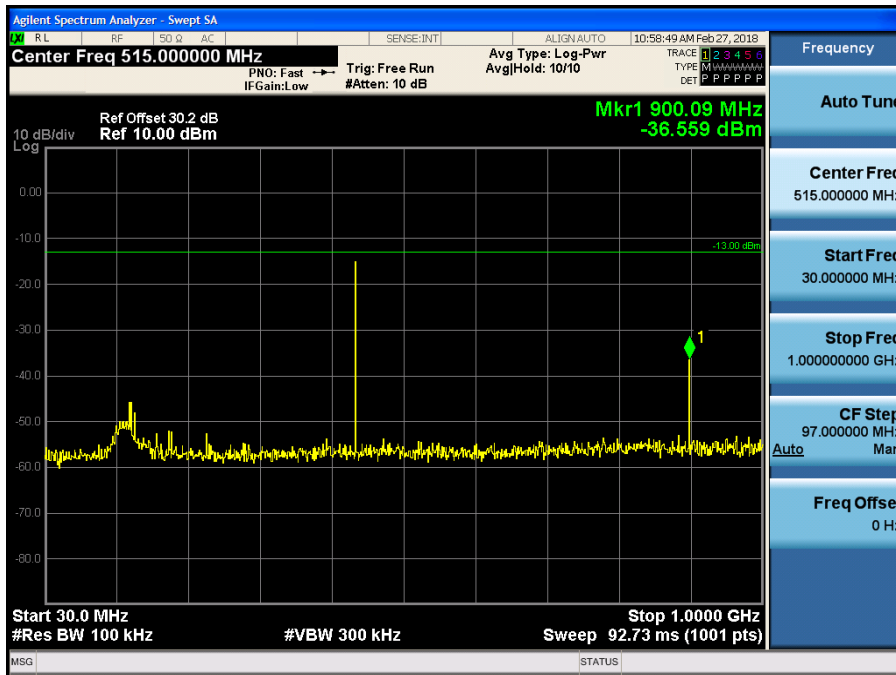

1 GHz~5.5 GHz

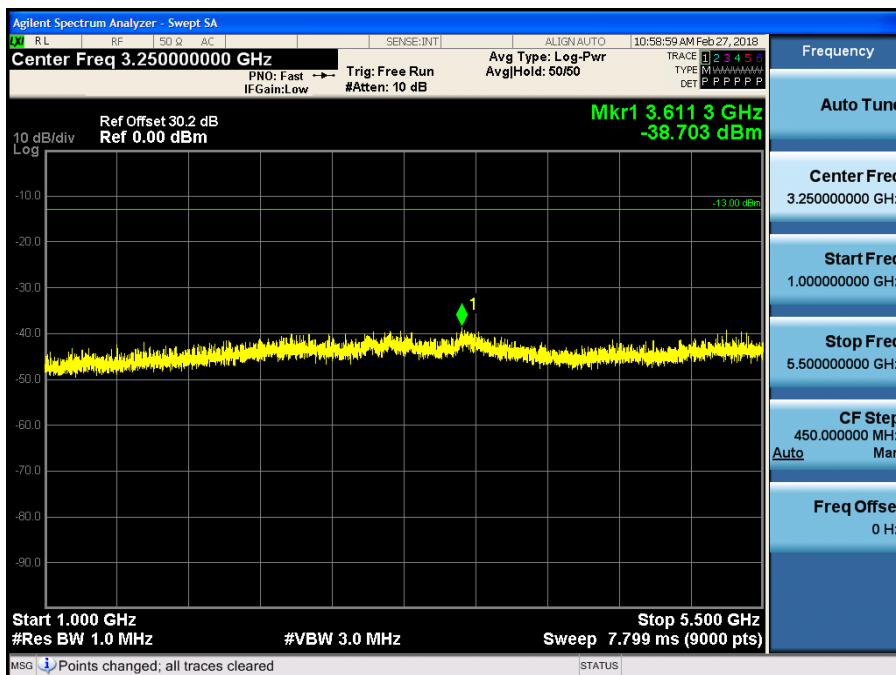

16K0F3E _ 460.05 MHz_High

9 kHz~150 kHz

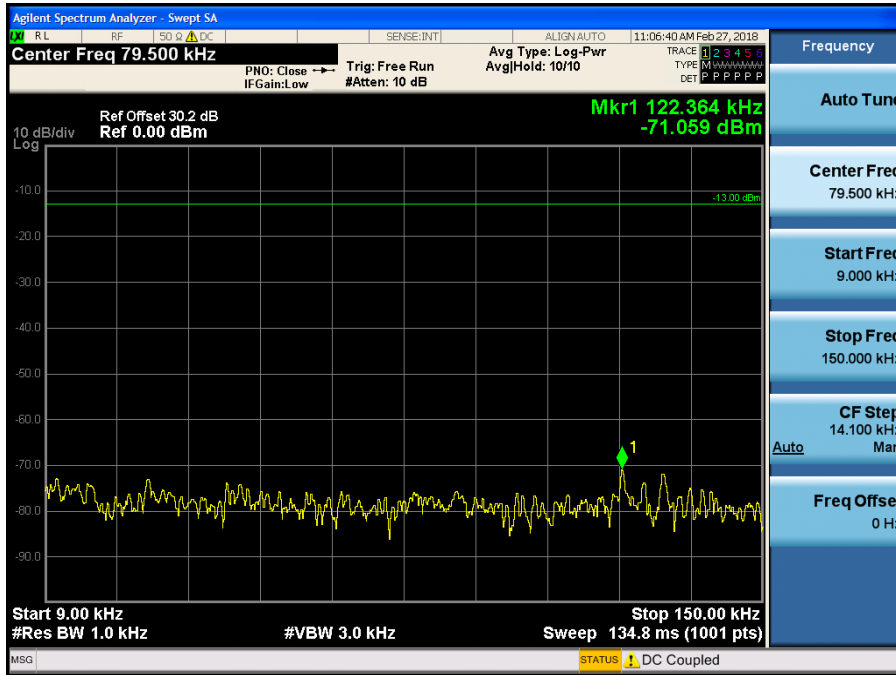

150 kHz~30 MHz

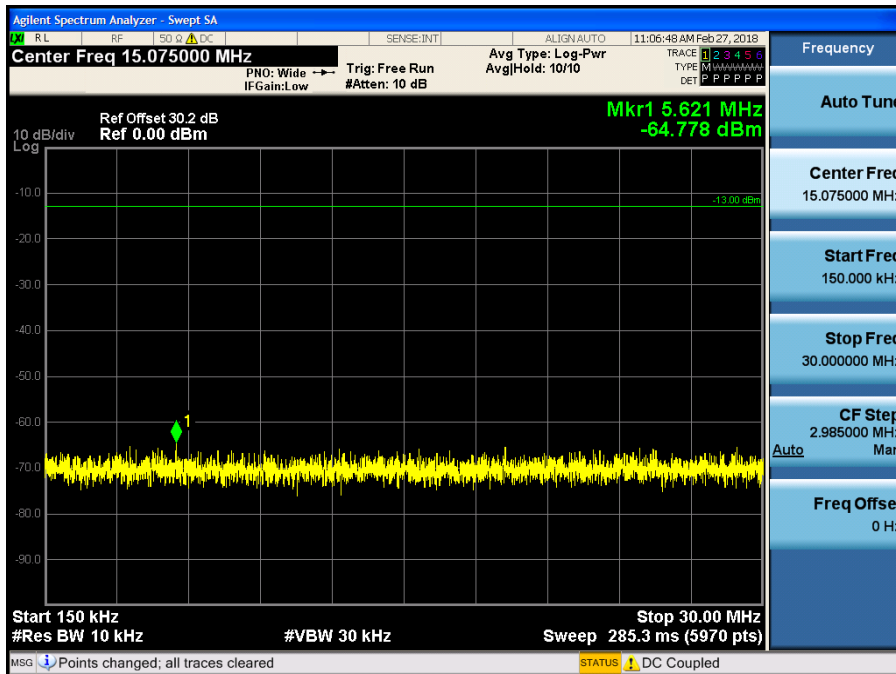

30 MHz~1 GHz

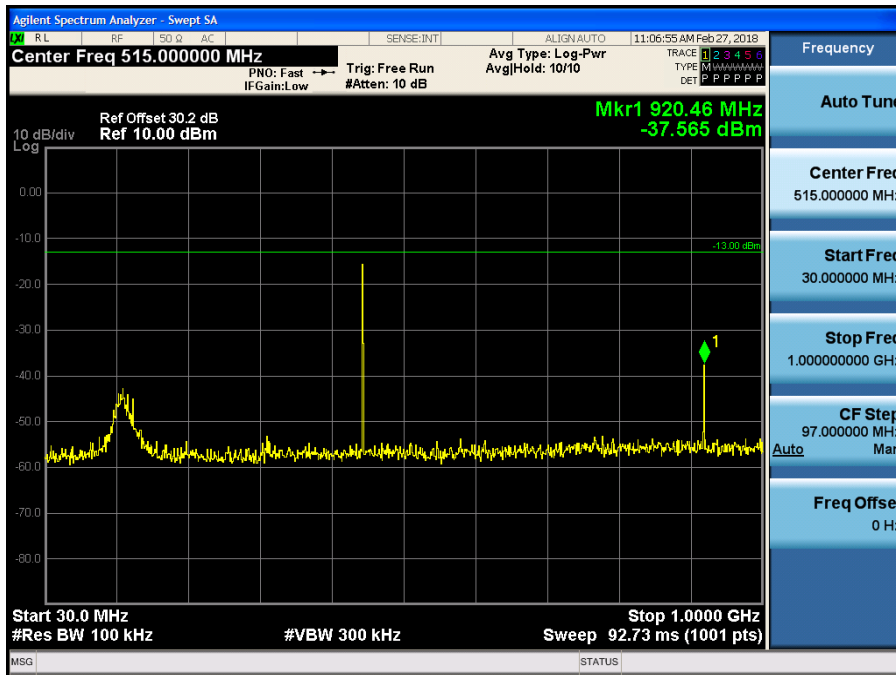

1 GHz~5.5 GHz

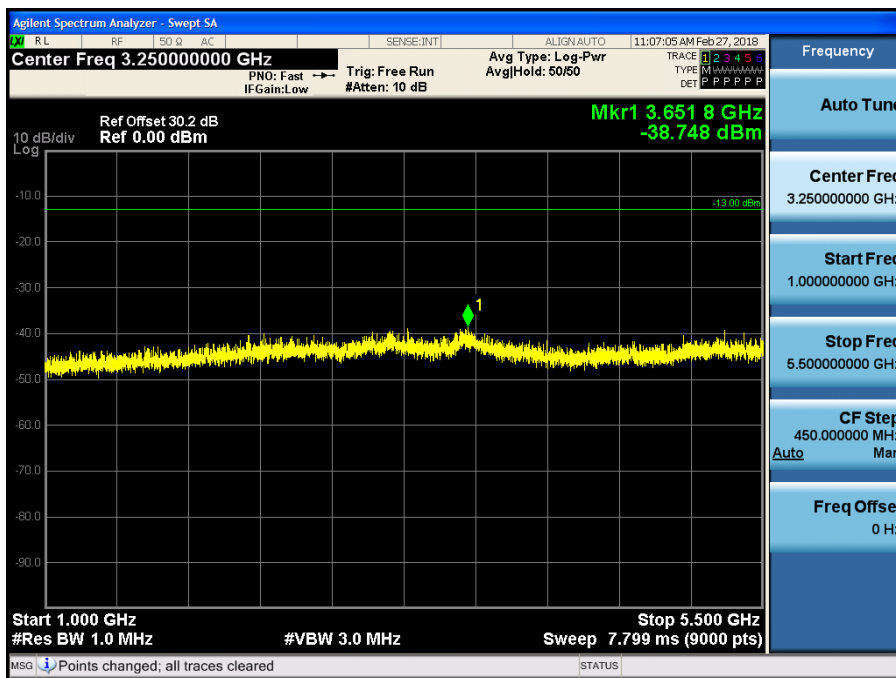

16K0F3E _ 469.95 MHz_High

9 kHz~150 kHz

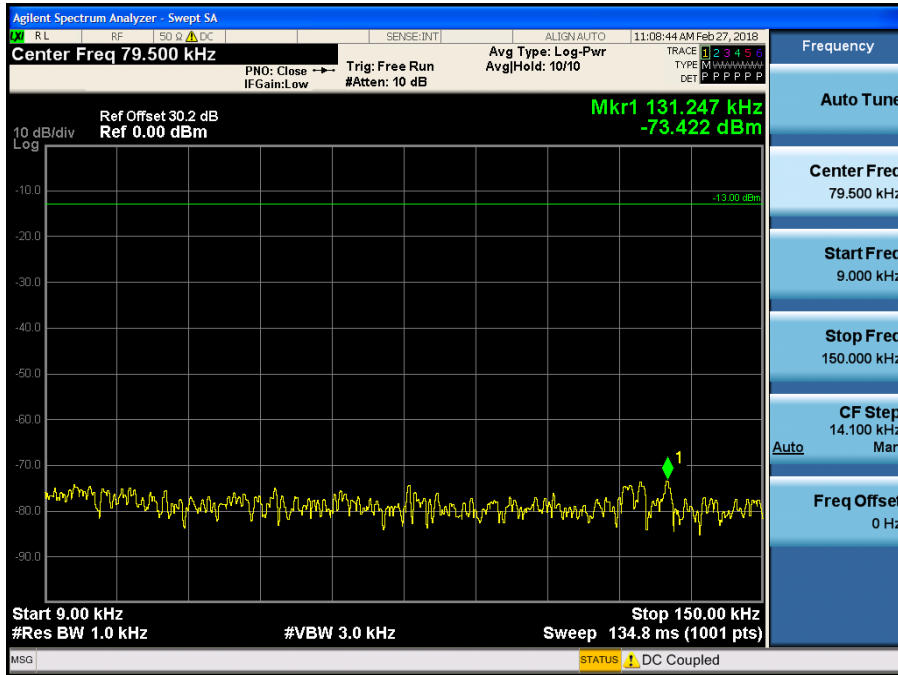

150 kHz~30 MHz

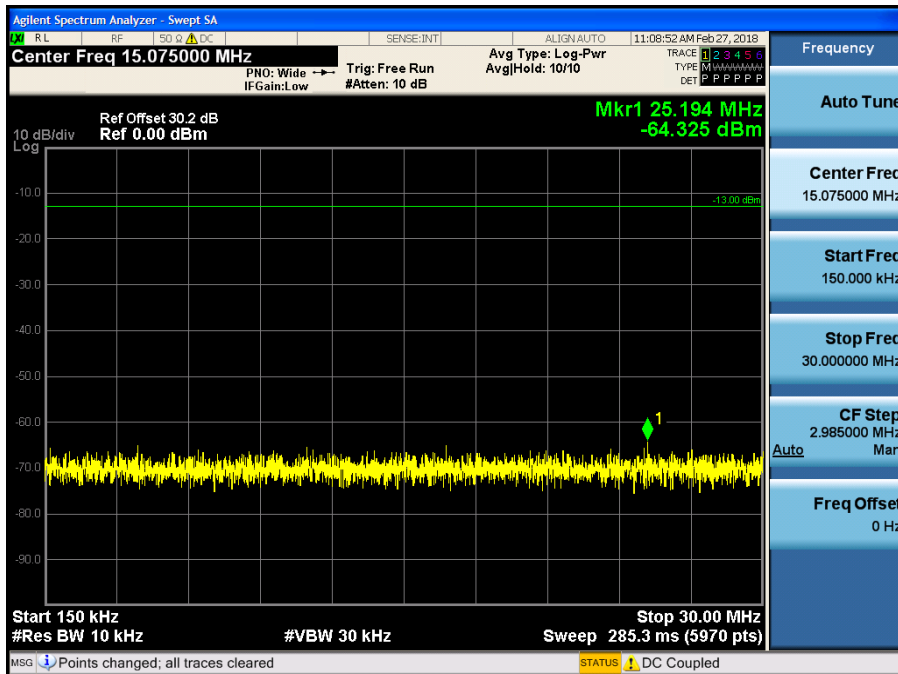

30 MHz~1 GHz

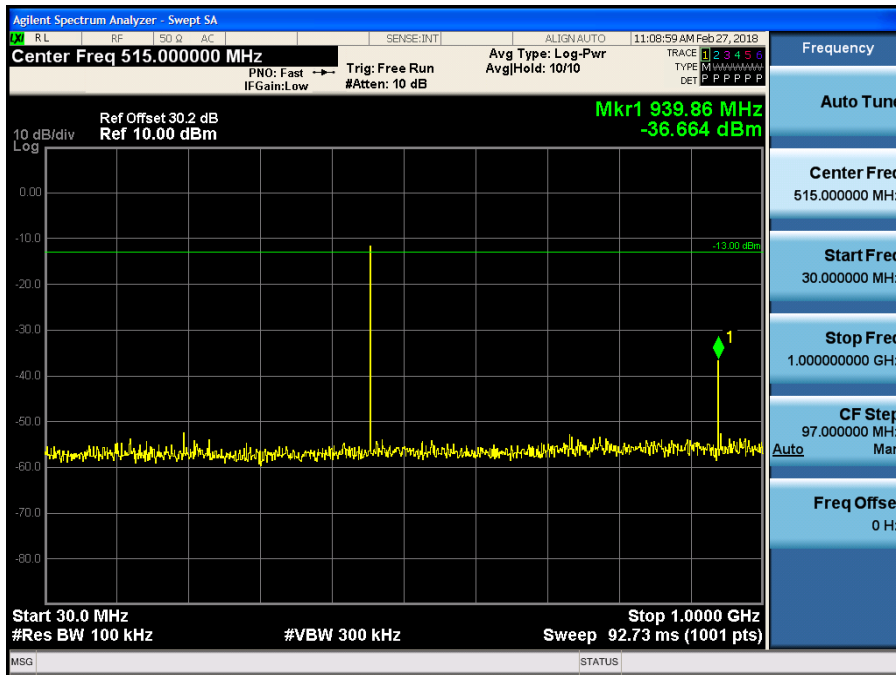

1 GHz~5.5 GHz

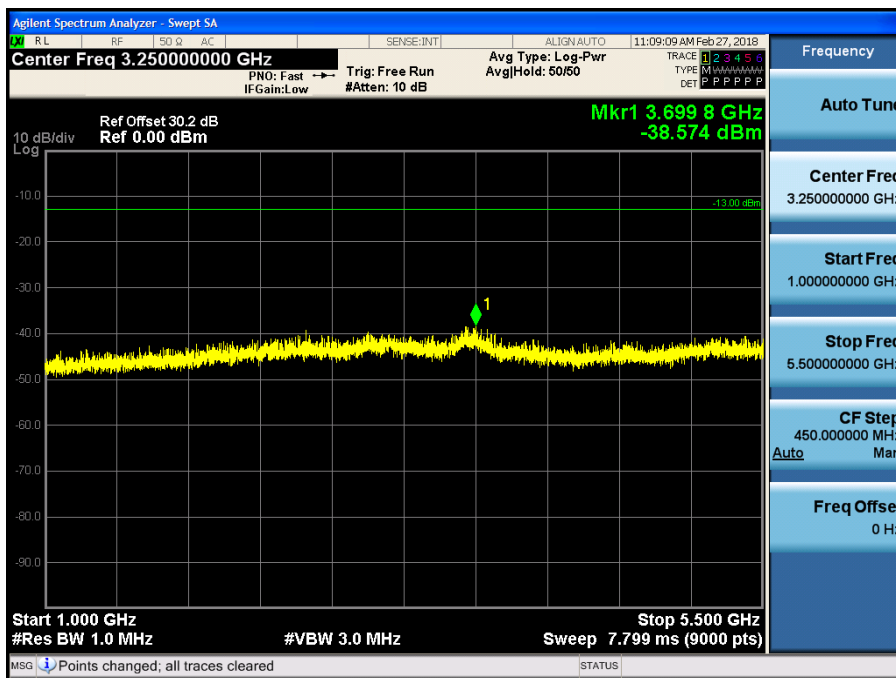

16K0F3E _ 450.05 MHz_Low

9 kHz~150 kHz

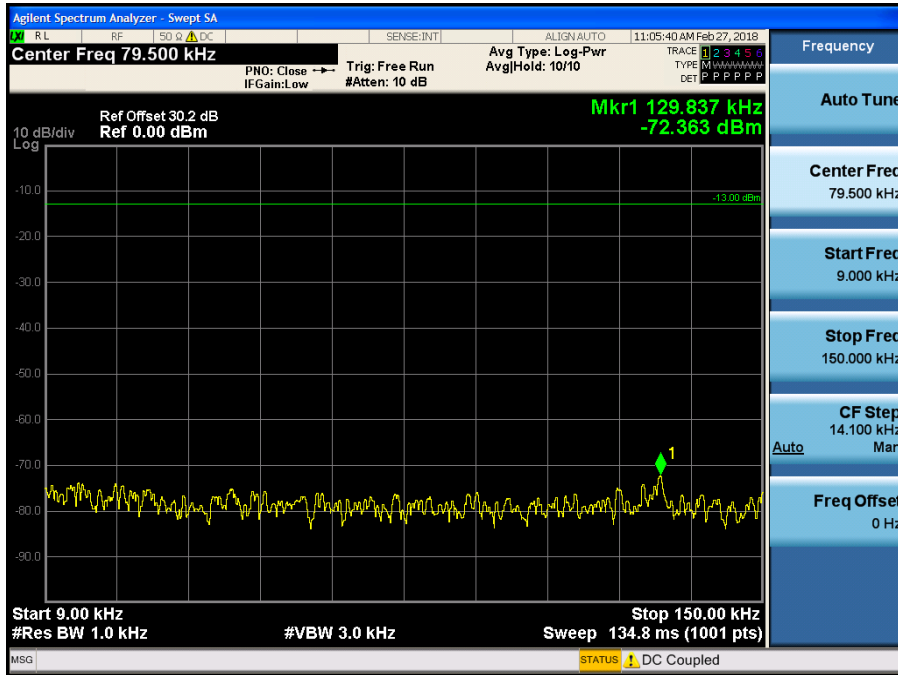

150 kHz~30 MHz

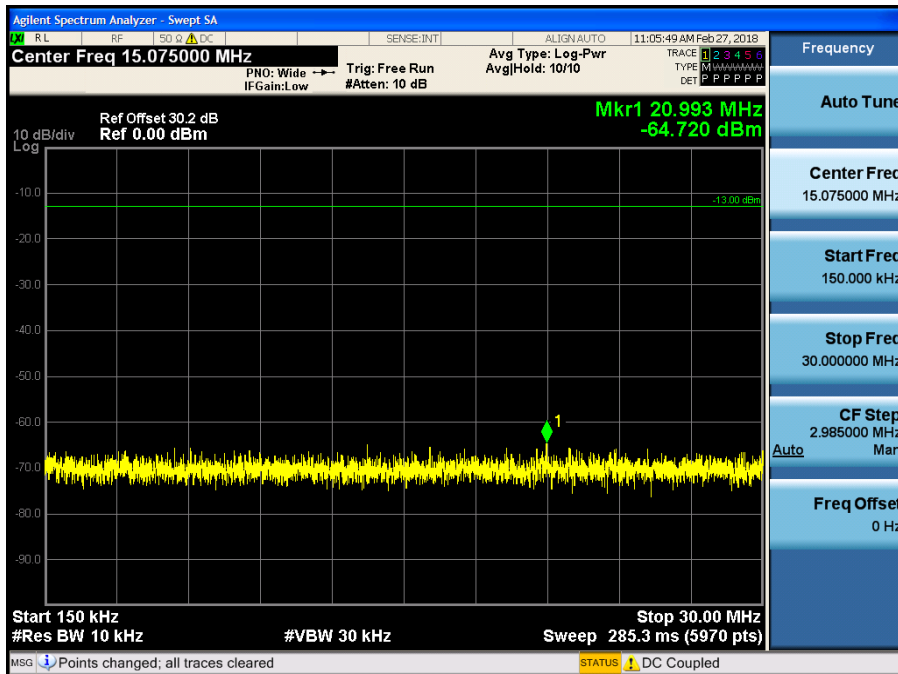

30 MHz~1 GHz

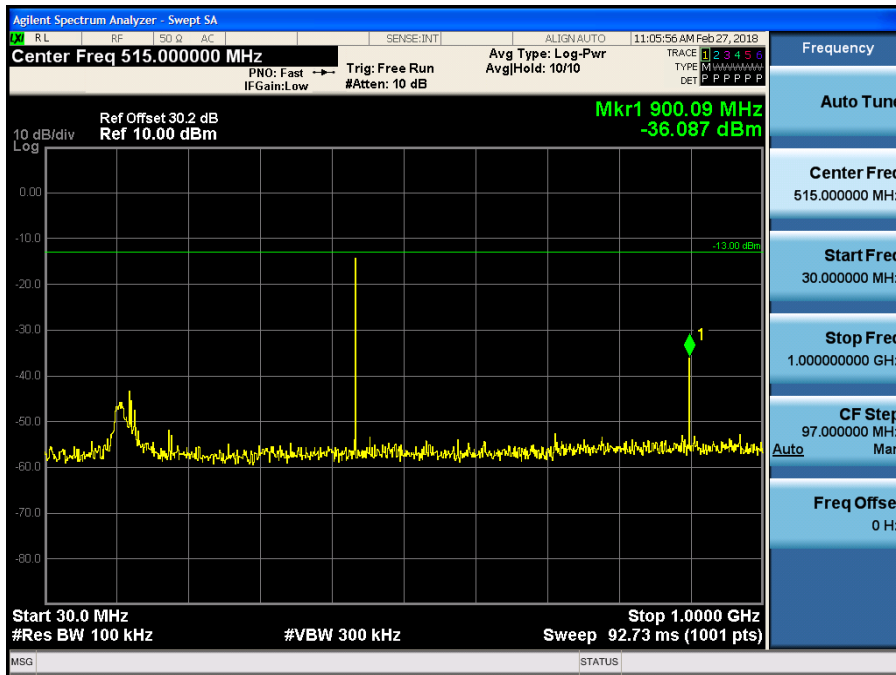

1 GHz~5.5 GHz

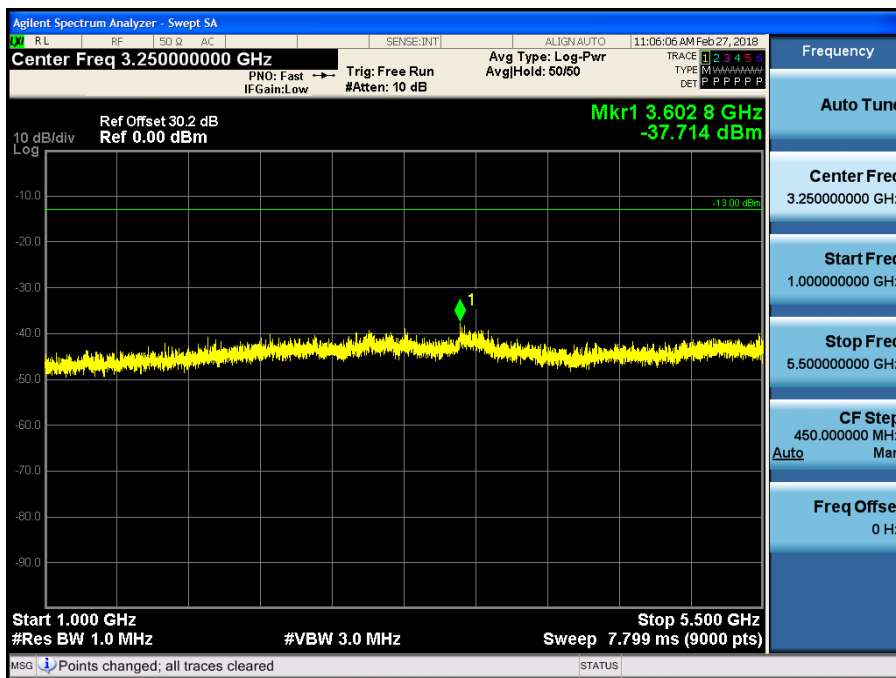

16K0F3E _ 460.05 MHz_Low

9 kHz~150 kHz

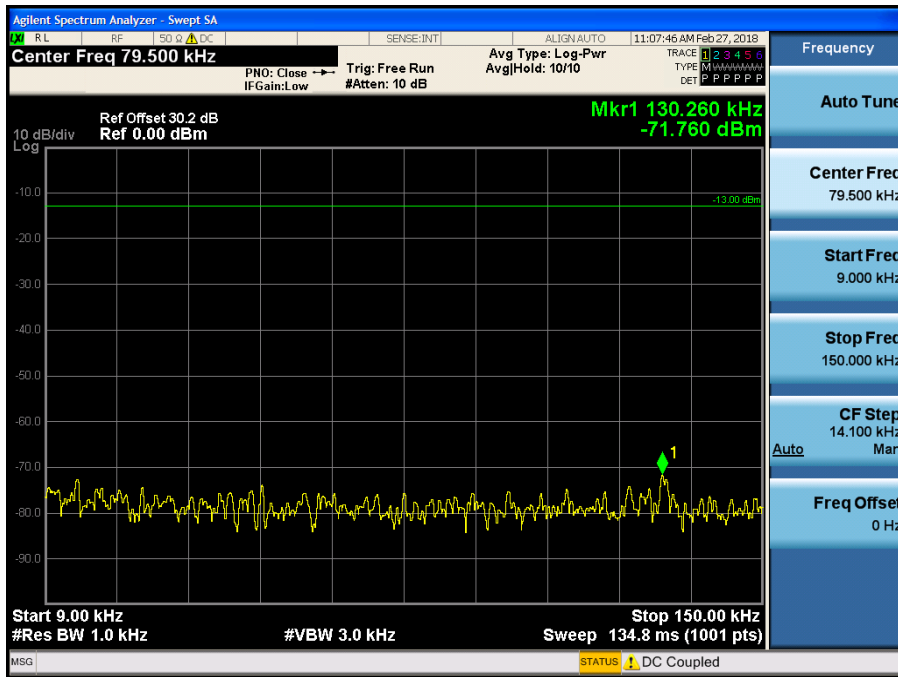

150 kHz~30 MHz

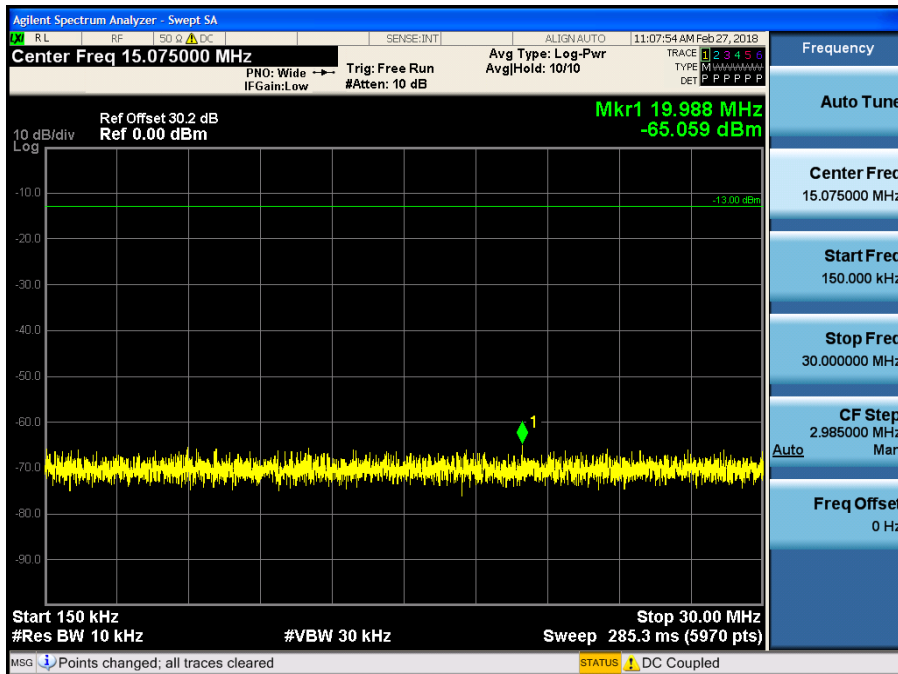

30 MHz~1 GHz

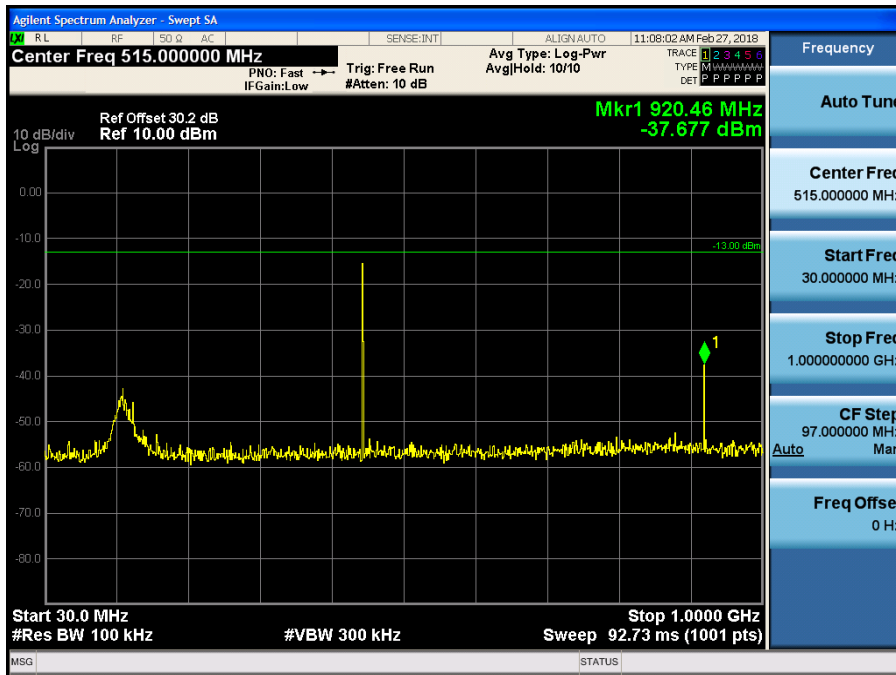

1 GHz~5.5 GHz

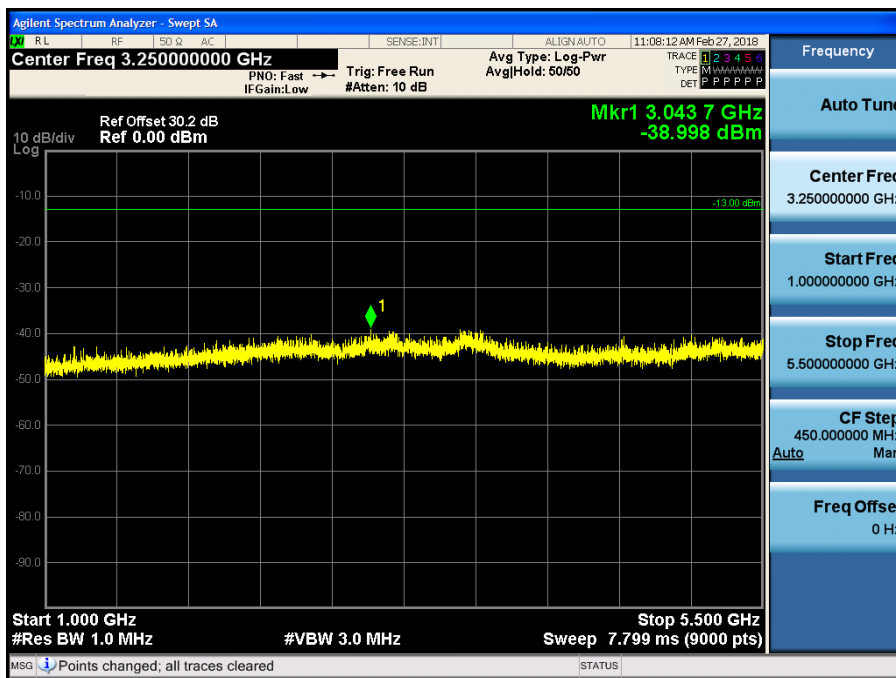

16K0F3E _ 469.95 MHz_Low

9 kHz~150 kHz

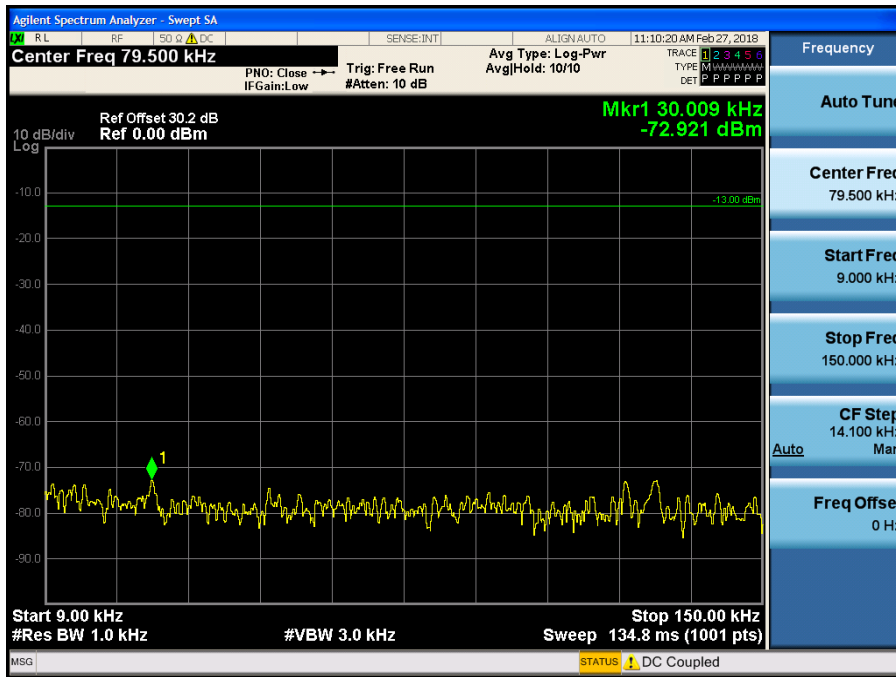

150 kHz~30 MHz

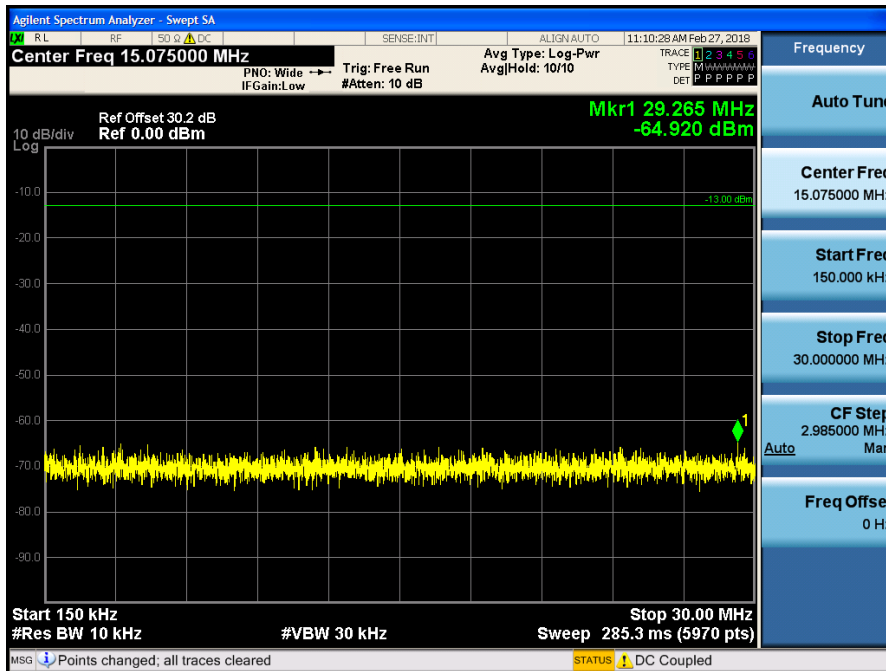

30 MHz~1 GHz

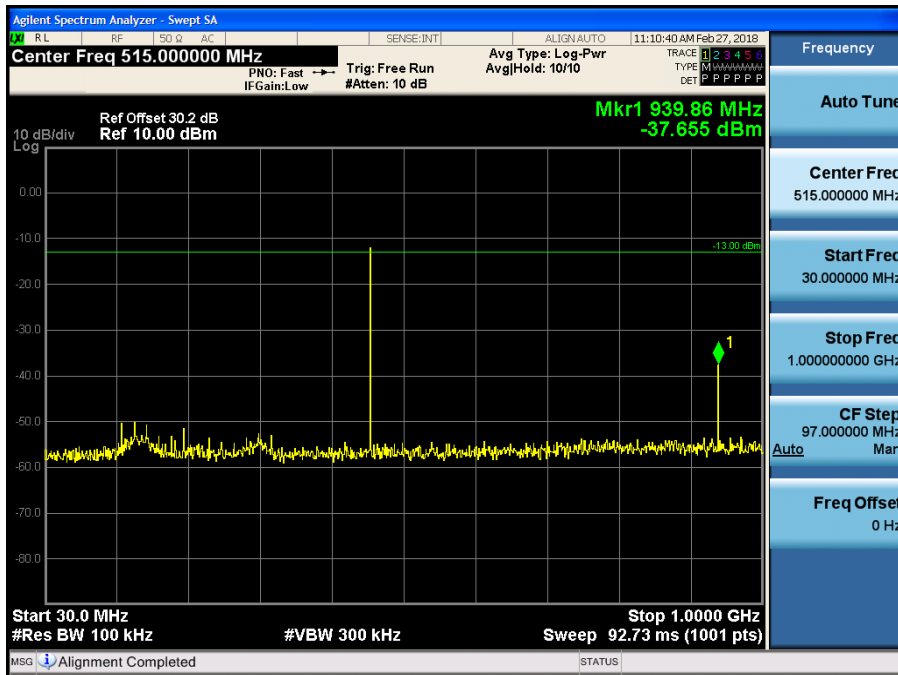

1 GHz~5.5 GHz

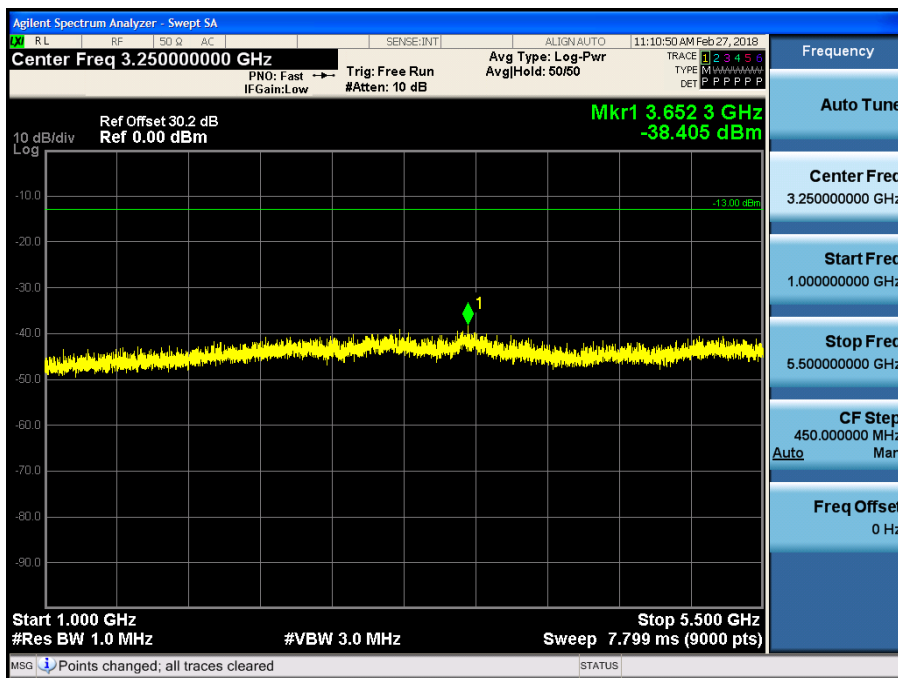

8K30F1E, 8K30F1D, 8K30F7W _ 450.05 MHz_High

9 kHz~150 kHz

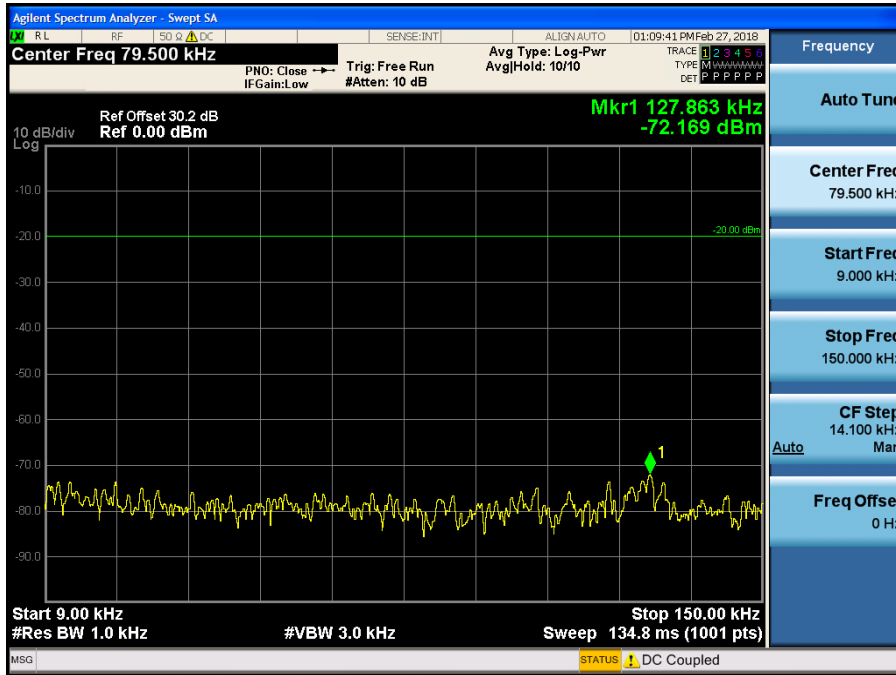

150 kHz~30 MHz

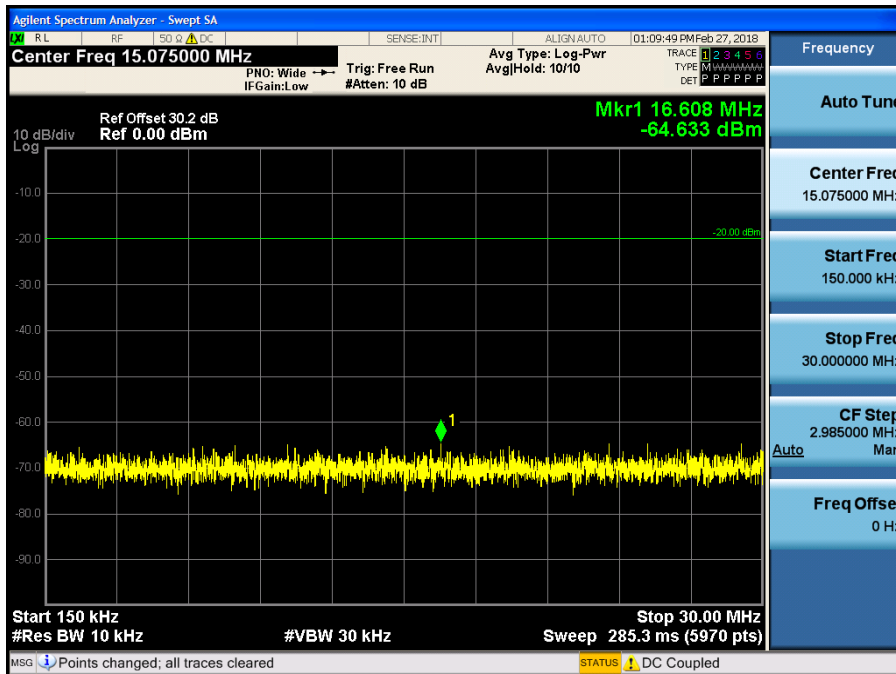

30 MHz~1 GHz

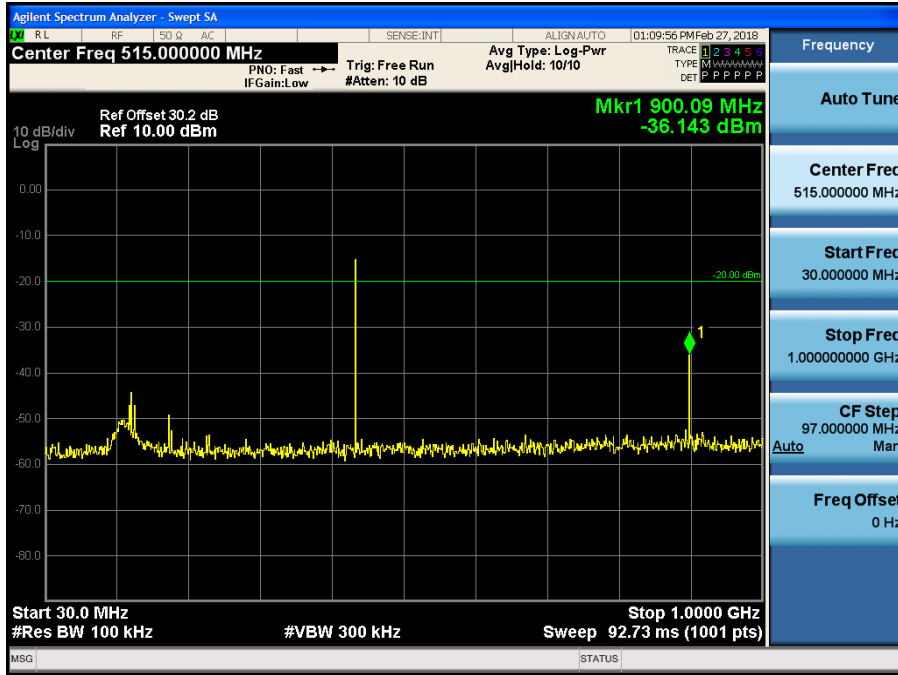

1 GHz~5.5 GHz

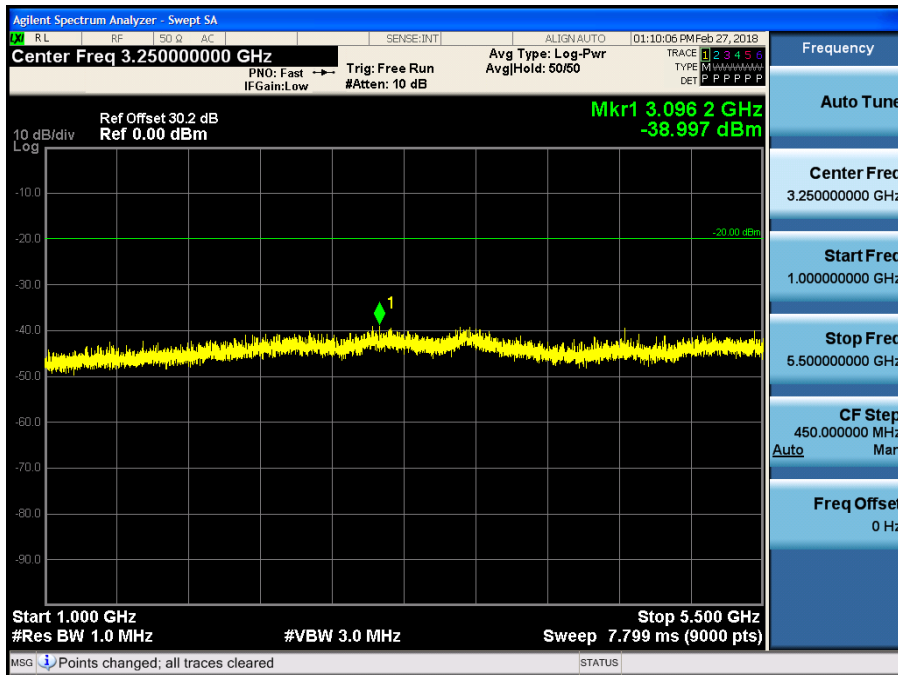

8K30F1E, 8K30F1D, 8K30F7W _ 460.05 MHz_High

9 kHz~150 kHz

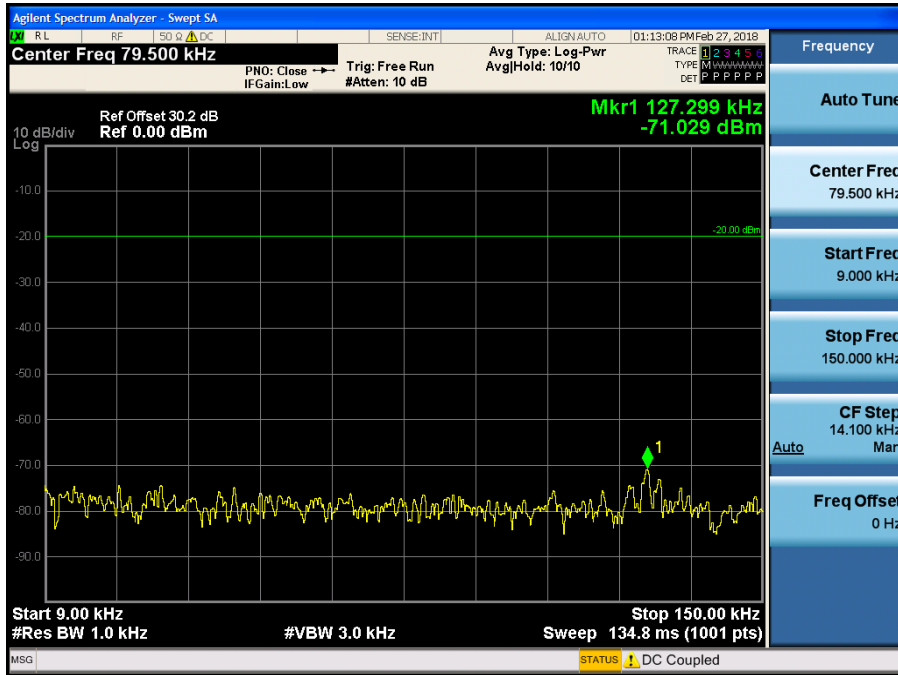

150 kHz~30 MHz

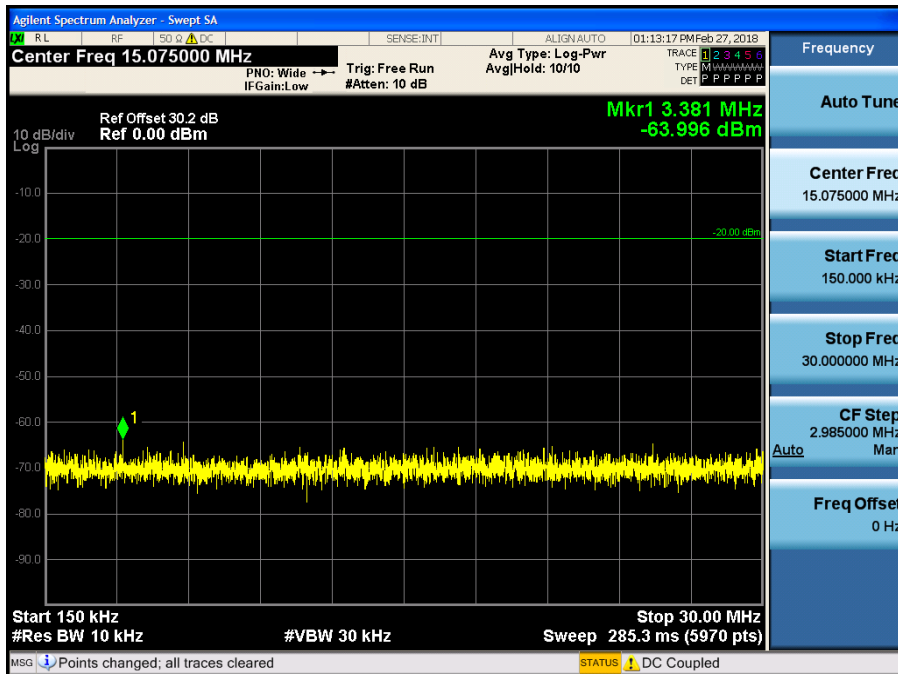

30 MHz~1 GHz

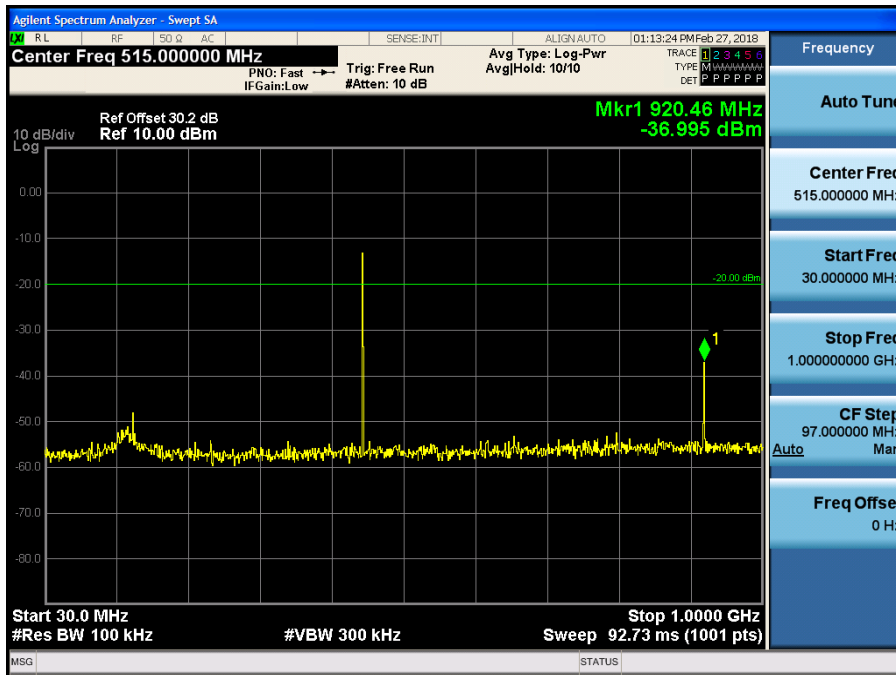

1 GHz~5.5 GHz

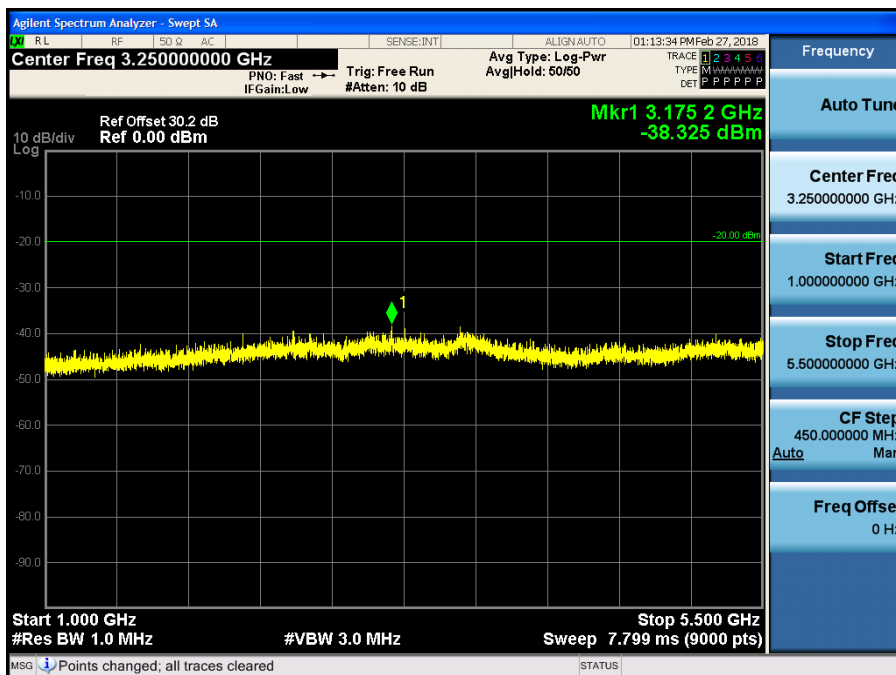

8K30F1E, 8K30F1D, 8K30F7W _ 469.95 MHz_High

9 kHz~150 kHz

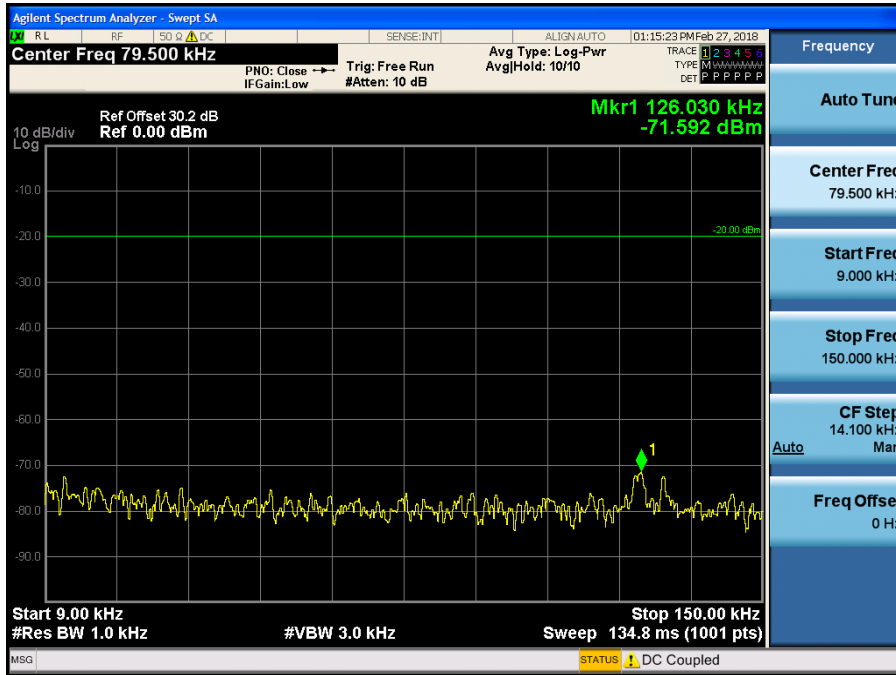

150 kHz~30 MHz

