



TEST REPORT

REGULATION : FCC Part 2, 90
 RSS-119 Issue 12

Applicant	Testing Laboratory
JVC KENWOOD Corporation 1-16-2, Hakusan, Midori-ku, Yokohama-shi Kanagawa, 226-8525 Japan Tel.: +81 45 939 6254 Fax.: +81 45 939 6261	Intertek Japan K.K. Kashima Laboratory URL: http://www.japan.intertek-etlsemko.com (Anechoic chamber) 298-6 Sada, Kashima, Ibaraki 314-0027 Japan Tel. +81 299 82 8464 (Open area test site) 3-2 Sunayama, Kamisu, Ibaraki 314-0255 Japan Tel. +81 479 40 1097

Equipment type	700/800MHz DIGITAL TRANSCEIVER
Trademark	KENWOOD
FCC Model(s)	NX-5900-K, NX-5900-F
IC Model(s)	NX-5900-K, TK-5930-F, VM5930-F
Serial No.	B5B10010
FCC ID	K44478500
IC CN and UPN	282F-478500
Test Result	Complied
Report Number	16060294JKA-001
Original Issue Date	July 22, 2016
Revised Issue Date	August 04, 2016

This report is for the exclusive use of Intertek's Client and is provided pursuant to the agreement between Intertek and its Client. Intertek's responsibility and liability are limited to the terms and conditions of the agreement. Intertek assumes no liability to any party, other than to the Client in accordance with the agreement, for any loss, expense or damage occasioned by the use of this report. Only the Client is authorized to permit copying or distribution of this report and then only in its entirety. Any use of the Intertek name or one of its marks for the sale or advertisement of the tested material, product or service must first be approved in writing by Intertek. The observations and test results in this report are relevant only to the sample tested. This report by itself does not imply that the material, product, or service is or has ever been under an Intertek certification program.

Approved by

Hideaki Kosemura
 [Technical Dept. Manager]

Tested by

Koichi Wagatsuma
 [Engineer]



VLAC-008-1

In Accordance with FCC Rules and Regulations, Volume II, Part 2 and 90**Sub-part 2.1033**

Applicant and Manufacture Information	
APPLICANT	
Company	: JVC KENWOOD Corporation
Address	: 1-16-2, Hakusan, Midori-ku, Yokohama-shi Kanagawa, 226-8525 Japan
Contact Person	: Tamaki Shimamura Manager, Communications Systems Business Unit
MANUFACTURER	
Company	: JVC KENWOOD Corporation
Address	: 1-16-2, Hakusan, Midori-ku, Yokohama-shi Kanagawa, 226-8525 Japan
(c)(2) FCC ID / IC CN and UPN	
FCC ID	: K44478500
IC CN and UPN	: 282F-478500
FCC Model(s)	: NX-5900-K, NX-5900-F
IC Model(s)	: NX-5900-K, TK-5930-F, VM5930-F
Serial number	: B5B10010
Instruction Manual(S)	
Instruction manual(s)	: Please refer to attached Exhibits F
Type of Emission	
Emission Designation	: 16K0F3E(Wide), 14K0F3E(Wide) 11K0F3E(Narrow) 8K10F1E(Narrow) / 8K10F1D(Narrow) / 8K10F1W(Narrow) 8K30F1E(Narrow) / 8K30F1D(Narrow) / 8K30F7W(Narrow) 4K00F1E(Very Narrow) / 4K00F1D(Very Narrow) / 4K00F7W(Very Narrow) 4K00F2D(Very Narrow) (Add Emission Designation is 7K60FXE/FXD) (Test Emission Designation is 7K60FXE/FXD)
Frequency range	
Frequency Range	: FCC: 769 to 775 MHz, 799 to 805 MHz, 806 to 824 MHz and 851 to 869 MHz IC: 768 to 776 MHz, 798 to 806 MHz, 806 to 824 MHz and 851 to 869 MHz
Power Rating	
Output Power	: 2 to 30 W (768 to 806MHz), 2 to 35 W (806 to 869MHz) :FCC 2 to 30 W (768 to 806MHz), 2 to 30 W (806 to 869MHz) :IC
Type	: Continuously Variable
Maximum Power Rating	
Output Power	: 30 W (768 to 806MHz), 35 W (806 to 869MHz) :FCC 30 W (768 to 806MHz), 30 W (806 to 869MHz) :IC
Voltages & currents in all elements in final RF stage, including final transistor or solid-state device	
Collector Current, A	: 13.0 A Maximum
Collector Voltage, Vdc	: 13.6 Vdc
Supply Voltage, Vdc	: 13.6 Vdc
Other Information	
Number of Channel	: Zone 128max. Cannels 512 max.(per Zone)
Maximum Deviation	: ± 5 kHz (16K0F3E), ± 4 kHz (14K0F3E), ± 2.5 kHz (11K0F3E)
Frequency Stability	: 1 ppm (768 to 776 MHz, 798 to 806 MHz) / 0.4 ppm with AFC (798 to 806 MHz)
	: 1 ppm (806 to 824 MHz, 851 to 869 MHz)
Antenna Impedance	: 50 Ω Norminal
Note	

TABLE OF CONTENTS

	Page
SECTION 1. GENERAL INFORMATION	4
SECTION 2. SUMMARY OF TEST RESULT	5
SECTION 3. TEST AND MEASUREMENT DATA	6
SECTION 4. INFORMATION ABOUT EUT AND SUPPORT EQUIPMENT(S)	7
SECTION 5. OPERATING CONDITION	8
SECTION 6. MEASUREMENT UNCERTAINTY	9
SECTION 7. TEST DATA	
7.1 Carrier Output Power (Conducted)	10
7.2 Unwanted Emissions (Transmitter Conducted)	13
7.3 Field Strength of Spurious Radiation	16
7.4 Emission Masks (Occupied Bandwidth)	22
7.5 Emission Limitations	31
7.6 Necessary Bandwidth and Emission Bandwidth	40
7.7 99% Occupied Bandwidth	41
APPENDIX PHOTOGRAPHS	

SECTION 1. GENERAL INFORMATION

TEST PERFORMED

Location	Kashima No.1 Test Site and No.12 Test Site		
EUT Received	June 27, 2016		
Date of Test	June 28, 2016	to	July 14, 2016
Standard Applied	FCC Part 2, 90 RSS-119 Issue 12		
Measurement Method	ANSI/TIA-603-D-2010 / RSS-119 Issue 12(2015), RSS-Gen Issue 4(2014)		
Deviation from Standard(s)	Not applicable		

QUALIFICATIONS OF TESTING LABORATORY (Kashima Lab.)

ACCREDITATION	SCOPE	LAB. CODE	Remarks
VLAC	EMC Testing	VLAC-008-1	JAPAN
BSMI	EMC Testing	SL2-IN-E-6008	TAIWAN
FILING			
VCCI	EMC Testing	A-0126	JAPAN
FCC	EMC Testing	JP0008	USA
IC	EMC Testing	IC-2042Q-12	CANADA
CB-Scheme	EMC Testing	TL222	IECEE

ABBREVIATIONS

EUT	Equipment Under Test	DoC	Declaration of Conformity
AMN	Artificial Mains Network	ISN	Impedance Stabilization Network
LISN	Line Impedance Stabilization Network	Q-P	Quasi-peak
AMP	Amplifier	AVG	Average
ATT	Attenuator	PK	Peak
ANT	Antenna	Cal	Calibration
BBA	Broadband Antenna	N/A	Not applicable or Not available
DIP	Dipole Antenna	LCD	Liquid-Crystal Display
AE	Associated Equipment	4LEVEL FSK	4LEVEL Frequency Shift Key
GMSK	Gaussian Maximum Shift Key	CW ID	Continuously Repeating bit stream
FM	Frequency Modulation	C4FM	Constant envelope 4 Level FM
PTT	Push to Talk	AFC	Automatic frequency control

Revision Summary

Revised Date	Section	Description of Changes
Aug 04, 2016	7.4	Add The selection of Emission Mask
Aug 04, 2016	7.6	Add types of modulation of the main carrier , nature of signal(s) modulating the main carrier: , type of information to be

SECTION 2. SUMMARY OF TEST RESULT

FCC Part2	Part90	IC RSS-119	TEST ITEM	RESULTS	Comments
2.1046 (a)	-	5.4	Carrier Output Power (Conducted)	PASS	
2.1051	90.210	5.8	Unwanted Emissions (Transmitter Conducted)	PASS	
2.1053 (a)	90.210	5.8	Field Strength of Spurious Radiation	PASS	
2.1049 (c) (1)	90.210	5.5	Emission Masks (Occupied Bandwidth)	PASS	
-	90.214	5.9	Transient Frequency Behavior	N/A	See Note
2.1047 (a)	-	-	Audio Low Pass Filter (Voice Input)	N/A	See Note
2.1047 (a)	-	-	Audio Frequency Response	N/A	See Note
2.1047 (b)	-	-	Modulation Limiting	N/A	See Note
2.1055 (a) (1)	90.213 (a)	5.3	Frequency Stability (Temperature Variation)	N/A	See Note
2.1055 (d) (1)	90.213 (a)	5.3	Frequency Stability (Voltage Variation)	N/A	See Note
-	-	RSS-Gen 7.1	Receiver Spurious Emissions	N/A	See Note
-	90.203 (i)	-	Certification required (FCC Part 90.203(i))	Complied	
-	90.203 (e)	-	Certification required (FCC Part 90.203(e))	Complied	
-	-	5.5	99% Occupied Bandwidth	PASS	
2.1049	90.543	5.5	Emission limitations		
			ACP Measurements	N/A	See Note
			Out-of-band emission limit :Conducted	PASS	
			Out-of-band emission limit : Radiated	PASS	
			EIRP in GNSS Band:1559-1610MHz (Conducted Calculated)	N/A	See Note

Note

Report is intended for Class 2 Permissive Change which is adding modulation bandwidths.

(add 7K60FXE/FXD)

This test is not applicable as the addition would not alter these measurements.

Limitation on Results

The test result of this report is effective equipment under test itself and under the test configuration described on the report.

This test report does not assure that whether the test result taken in other testing laboratory is compatible or reproducible to the test result on this report or not.

Note:

As for the FCC Part 15 Subpart B-Unintentional Radiators, the EUT has been measured and declared as Verification by JVC Kenwood Corporation.

SECTION 3. TEST AND MEASUREMENT DATA

All test and measurements indicated in this document were performed in accordance with the Code of Federal Regulations Title 47 Part 2, Sub-part J and Industry Canada as the following individual parts

FCC Rule	Test Item	Tested
Part 21	Domestic Public Fixed radio Services	N.A.
Part 22	Non Cellular	N.A.
Part 22	Public Mobile Services	N.A.
Part 22	Subpart H - Cellular Radiotelephone Service	N.A.
Part 22	Alternative technologies and auxiliary service	N.A.
Part 23	International Fixed Public Radiocommunication service	N.A.
Part 24	Personal Communications Services	N.A.
Part 74	Experimental Radio Auxiliary , Special Broadcast and Other Program Distributional Services	N.A.
Part 80	Stations in the Maritime Services	N.A.
Part 80	Subpart E - general Technical Standards	N.A.
Part 80	Subpart F - Equipment Authorization for Compulsory Ships	N.A.
Part 80	Subpart K - Private Coast Stations and Marine Utility Stations	N.A.
Part 80	Subpart S - Compulsory radiotelephone Installations for Small Passenger Boats	N.A.
Part 80	Subpart T - Radiotelephone Installation Required for Vessels on the Great Lakes	N.A.
Part 80	Subpart U - Radiotelephone Installations Required by the Bridge-to- Bridge Act	N.A.
Part 80	Subpart V - Emergency Position Indicating Radiobeacons (EPIRB'S)	N.A.
Part 80	Subpart W - Global Maritime Distress and Safety System (GMDSS)	N.A.
Part 80	Subpart X - Voluntary Radio Installations	N.A.
Part 87	Aviation Services	N.A.
Part 90	Private Land Mobile radio Services	YES
Part 94	Private Operational - Fixed Microwave Service	N.A.
Part 95	Subpart A - General Mobile radio Service	N.A.
Part 95	Subpart C - Radio Control (R/C) radio Service	N.A.
Part 95	Subpart D - Citizens Band (CB) Radio Service	N.A.
Part 95	Subpart E -Family radio Service	N.A.
Part 95	Subpart F -Interactive Video and Data Service (IVDS)	N.A.
Part 97	Amateur Radio Service	N.A.
Part 101	Fixed Microwave Service	N.A.

IC Rule	Test Item	Tested
RSS-119	Radio Ttansmitters and Receivers Operating in the Land Mobile and Fixed Services in the Frequency Range 27.4-960 MHz	YES
RSS-134	900MHz Narrowband Personal Communication Service	N.A.
RSS-Gen	General Requirements for Compliance of Radio Apparatus	YES

SECTION 4. INFORMATION ABOUT EUT AND SUPPORT EQUIPMENT(S)

4.1 List of System Configuration

Symbol	Item	Model No.	Serial No.	Manufacture	Remarks
A	700/800MHz DIGITAL TRANSCEIVER	NX-5900-K NX-5900-F	B5B10010	JVC KENWOOD Corporation	EUT
Power Ratings of EUT :		13.6 V +/- 15%	13.0 A Maximum		
Power Supply :		DC 13.6 V			
Condition of Equipment		Proto type			
Type		Mobile type			
Suppression Devices		No Modifications by the laboratory were made to the device			

4.2 Port(s)/Connector(s)

Port Name	Connector Type	Connector Pin	Remarks
ACC	D-sub	25 pin	
External Speaker	3.5φ	2 pin	
RF Antenna	M	2 pin	
GPS Antenna	SMA	2 pin	
Ignition sense	Original	2 pin	

4.3 Highest Frequency Oscillator(s)/Crystal(s)

Operating Frequency	Board Name	Remarks
869 MHz	TXRX UNIT	
4960 MHz	Bluetooth UNIT	

SECTION 5. OPERATING CONDITION

The EUT was operated under the following condition during the test.

5.1 Operating Condition

The test was carried out under Transmit mode.

(FCC/RSS 769.05MHz, 774.95MHz, 799.05MHz, 804.95MHz,
806.05MHz, 815.05MHz, 823.95MHz, 851.05MHz, 860.05MHz, 868.95MHz)

(High Power : 30W, Low Power : 2 W

: 769.05MHz, 774.95MHz, 799.05MHz, 804.95MHz)

(High Power : 35W, Low Power : 2 W

: 806.05MHz, 815.05MHz, 823.95MHz, 851.05MHz, 860.05MHz, 868.95MHz)

5.2 Operating Flow [Transmit mode]

Following operations were performed continuously.

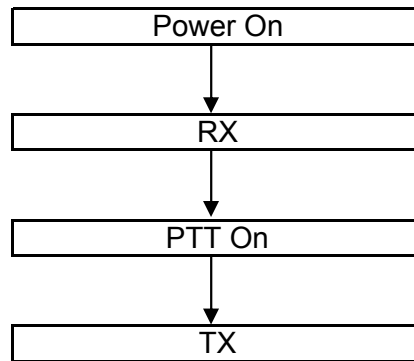

SECTION 6. MEASUREMENT UNCERTAINTY

Carrier Output Power (Conducted)	U _{lab}	Utia-603-d
	+/- 0.29dB (k = 2)	+/- 0.59 dB
Unwanted Emissions (Transmitter Conducted)		
	+/- 2.19 dB (k = 2)	+/- 1.1 dB
Field Strength of Spurious Radiation		
	+/- 2.78dB (k = 2)	+/- 3.3 dB
Emission Masks (Occupied Bandwidth)		
	+/- 0.5dB (k = 2)	+/- 2.1 dB
Transient Frequency Behavior		
	+/- 1.10% (k = 2)	+/- 21.6 %
Audio Low Pass Filter (Voice Input)		
	+/- 0.1dB (k = 2)	+/- 1.2 dB
Audio Frequency Response		
	+/- 0.1dB (k = 2)	+/- 1.2 dB
Modulation Limiting		
	+/- 1% (k = 2)	+/- 1.0 %
Frequency Stability (Temperature Variation)		
	+/- 10.1Hz (k=2)	+/-34.2 Hz
Frequency Stability (Voltage Variation)		
	+/- 10.1Hz (k=2)	+/-34.2 Hz
Emission Limitations § 90.543 (b) : ACP Measurements		
	+/- 0.59dB (k = 2)	+/- 1.2 dB
Emission Limitations § 90.543 (c) : Out-of-band emission limit :Conducted		
	+/- 2.19 dB (k = 2)	+/- 1.1 dB
Emission Limitations § 90.543 (c) : Out-of-band emission limit : Radiated		
	+/- 2.78dB (k = 2)	+/- 3.3 dB
Emission Limitations § 90.543 (f) : EIRP in GNSS Band:1559-1610MHz (Conducted)		
	+/- 2.19 dB (k = 2)	+/- 1.1 dB
Receiver Spurious Emissions	U _{lab}	Ucisp
30-1000MHz	+/- 4.43dB (k = 2)	+/- 6.3 dB
abobe 1GHz	+/- 4.44dB (k = 2)	

SECTION 7. TEST DATA

7.1 Carrier Output Power (Conducted)

REGULATIONS : FCC Part 2 Section 1046 (a) / RSS-119 Section 5.4

TEST METHOD/GUIDE : ANSI/TIA-603-D Section 2.2.1.2 / RSS-119 Section 4.1

Test Procedure

- 1 The EUT and test equipment were set up as shown on the following page.
- 2 The EUT was conducted to a resistive coaxial attenuator of normal load impedance.
 $RF\ Power\ (dBm) = Power\ Meter\ reading\ (dBm) + Attenuator\ Loss\ (dB) + Cable\ Loss\ (dB)$
 $RF\ Power\ (W) = 10^{(RF\ Power\ (dBm)/10)}/1000$
- 3 Modulate the transmitter with a 2.5 kHz sine wave at an input Level of 16 dB greater than that necessary to produce 50 % of rated system deviation.(Only as for the test of RSS)

Measuring Equipments

No.	Equipment	Manufacture	Model No.	Serial No.	Cal Date	Cal Exp.
1	Power Meter	Hewlett Packard	E4418B	GB38410265	May. 20, 16	May. 31, 17
2	Power Sensor	Hewlett Packard	8482A	US37292237	May. 20, 16	May. 31, 17
3	Attenuator (20dB)	Aeroflex/Wenschel	66-20-34	BY4357	May. 23, 16	May. 31, 17
4	Attenuator (30dB)	Weinschel	WA-29-30-34	8923	May. 23, 16	May. 31, 17
5	DC Power Supply	Daiichi denpa kogyo	GZV4000	90290931	None	None
6	Digital Multi Meter	FLUKE	8846A	9642018	Jul. 10, 15	Jul. 31, 16

Measuring Equipment Configuration

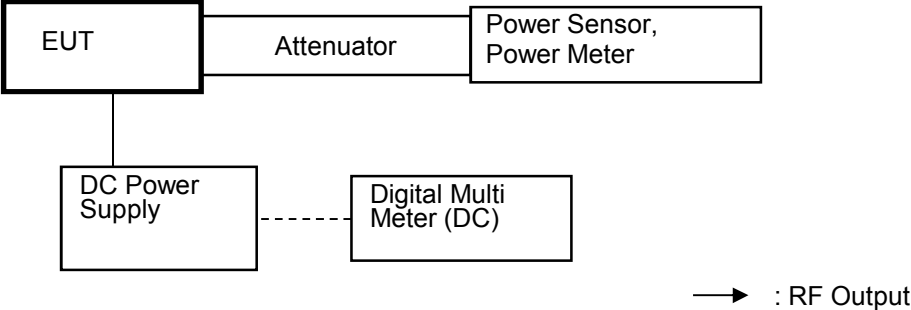

Test Results

Test date	Jun 28, 2016	
Location	Kashima No.1 Test Site	
temperature	25.8	[degree C]
Humidity Variation	60.0	[%]
Atmospheric Pressure	100.8	[kPa]
Test Engineer	Koichi Wagatsuma	

Test was carried out for all the Authorized Bandwidth.
 State the worst case (below).

No.	Frequency (MHz)	Band	Setting	RF Power (W)	
1	769.05 (Band 1)	Low	Band 1	High Power	30
2	774.95 (Band 1)	High	Band 1	High Power	30
3	799.05 (Band 2)	Low	Band 2	High Power	30
4	804.95 (Band 2)	High	Band 2	High Power	30
5	806.05 (Band 3)	Low	Band 3	High Power	35
6	815.05 (Band 3)	Middle	Band 3	High Power	35
7	823.95 (Band 3)	High	Band 3	High Power	35
8	851.05 (Band 4)	Low	Band 4	High Power	35
9	860.05 (Band 4)	Middle	Band 4	High Power	35
10	868.95 (Band 4)	High	Band 4	High Power	35
11	769.05 (Band 1)	Low	Band 1	Low Power	2
12	774.95 (Band 1)	High	Band 1	Low Power	2
13	799.05 (Band 2)	Low	Band 2	Low Power	2
14	804.95 (Band 2)	High	Band 2	Low Power	2
15	806.05 (Band 3)	Low	Band 3	Low Power	2
16	815.05 (Band 3)	Middle	Band 3	Low Power	2
17	823.95 (Band 3)	High	Band 3	Low Power	2
18	851.05 (Band 4)	Low	Band 4	Low Power	2
19	860.05 (Band 4)	Middle	Band 4	Low Power	2
20	868.95 (Band 4)	High	Band 4	Low Power	2

RF Power: Peak reading

7.2 Unwanted Emissions (Transmitter Conducted)

REGULATIONS	: FCC Part 2 Section 1051, Part 90 Section 210 / RSS-119 Section 5.8
TEST METHOD/GUIDE	: RSS-119 Section 4.2, RSS-Gen Section 4.9

Test Procedure

- 1 The EUT and test equipment were set up as shown on the following page.
- 2 Modulate the transmitter with a 2.5 kHz sine wave at an input Level of 16 dB greater than that than necessary to produce 50 % of rated system deviation.
- 3 Adjust the spectrum analyzer for the following setting:
 - a) RBW : 100 kHz (< 1 GHz), 1 MHz (> 1 GHz).
 - b) VBW : 300 kHz (< 1 GHz), 3 MHz (> 1 GHz).
 - c) Detector mode : Average power (FM Modulation) , Positive peak with peak hold (Digital Modulation)
- 4 The emissions were measured for the worst case as follows:
 - a) : within a band of frequencies defined by the carrier frequency plus and minus one channel.
 - b) : from the lowest frequency generated in the EUT and to at least the 10th harmonic of the carrier frequency, or 40 GHz, whichever is lower.

Measuring Equipments

No.	Equipment	Manufacture	Model No.	Serial No.	Cal Date	Cal Exp.
1	Attenuator (20dB)	Aeroflex/Wenschel	66-20-34	BY4357	May. 23, 16	May. 31, 17
2	Attenuator (30dB)	Weinschel	WA-29-30-34	8923	May. 23, 16	May. 31, 17
3	Highpass Filter	TME	UHP-127	1511798E	May. 19, 16	May. 31, 17
4	Signal Generator	Rohde&Schwarz	SMB 100A	105709	Apr. 01, 16	Apr. 30, 17
5	Spectrum Analyzer	Agilent	N9030A	US51350220	Dec. 02, 15	Dec. 31, 16
6	DC Power Supply	Daiichi denpa kogyo	GZV4000	90290931	None	None
7	Digital Multi Meter	FLUKE	8846A	9642018	Jul. 10, 15	Jul. 31, 16

Measuring Cables

No.	Cable	Manufacture	Model No.	Serial No.	Cal Date	Cal Exp.
W2	Coaxial Cable	Suhner	SUCOFLEX104	F0000018	Jan. 16, 16	Jan. 31, 17

Measuring Equipment Configuration

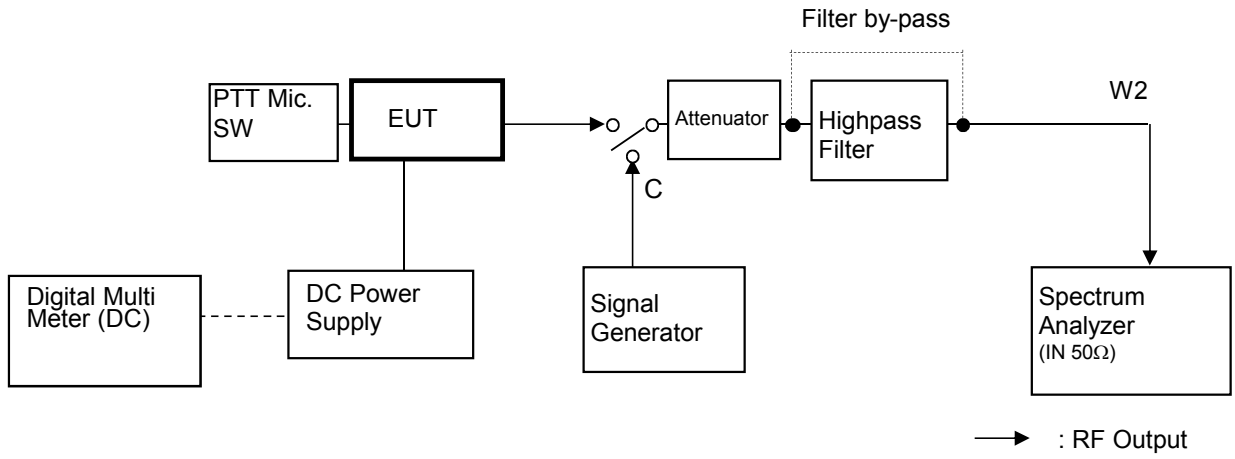

Test Results

Test date	Jul 13, 2016
Location	Kashima No.1 Test Site
temperature	25 [degree C]
Humidity Variation	67 [%]
Atmospheric Pressure	100.1 [kPa]
Test Engineer	Koichi Wagatsuma

Test was carried out for all the frequency band of section 7.1
 State the worst case (below).

State : High Power / Authorized Bandwidth 11.25 kHz

No.	Tuned Frequency (MHz)	Band	Spurious Frequency (MHz)	Correct Level (dBm)	Emission Level (dBc)	Mask D Limit (dBc)	Margin (dB)
1	806.05 (Band 3)	Low	2418.15	-30.37	-75.81	-65.4	10.4
2	815.05 (Band 3)	Middle	2445.15	-30.06	-75.50	-65.4	10.1
3	823.95 (Band 3)	High	2471.85	-28.44	-73.88	-65.4	8.5
4	851.05 (Band 4)	Low	1702.10	-31.27	-76.71	-65.4	11.3
5	860.05 (Band 4)	Middle	1720.10	-31.38	-76.82	-65.4	11.4
6	868.95 (Band 4)	High	1737.90	-31.56	-77.00	-65.4	11.6

There is the margin of 20dB over except for the above points.

Mask D Limit (dBc) = $-(50+10\log(P))$
 Correct Level (dBm) = Substitute SG Level (dBm)
 Emission Level (dBc) = Correct Level (dBm) - $10\log(P*1000)$
 P = Carrier Level (W)
 " - " = Measurement Limit

State : Low Power / Authorized Bandwidth 11.25 kHz

No.	Tuned Frequency (MHz)	Band	Spurious Frequency (MHz)	Correct Level (dBm)	Emission Level (dBc)	Mask D Limit (dBc)	Margin (dB)
1	806.05 (Band 3)	Low	No Point detected	-	-	-53.0	-
2	815.05 (Band 3)	Middle	No Point detected	-	-	-53.0	-
3	823.95 (Band 3)	High	No Point detected	-	-	-53.0	-
4	851.05 (Band 4)	Low	No Point detected	-	-	-53.0	-
5	860.05 (Band 4)	Middle	No Point detected	-	-	-53.0	-
6	868.95 (Band 4)	High	No Point detected	-	-	-53.0	-

There is the margin of 20dB over except for the above points.

Mask D Limit (dBc) = $-(50+10\log(P))$
 Correct Level (dBm) = Substitute SG Level (dBm)
 Emission Level (dBc) = Correct Level (dBm) - $10\log(P*1000)$
 P = Carrier Level (W)
 " - " = Measurement Limit

7.3 Field Strength of Spurious Radiation

REGULATIONS : FCC Part 2 Section 1053 (a), Part 90 Section 210 / RSS-119 Section 5.8

TEST METHOD/GUIDE : ANSI/TIA-603-D Section 2.2.12.2 / RSS-119 Section 4.2

Test Procedure

- 1 The EUT and test equipment were set up as shown on the following page.
- 2 Adjust the spectrum analyzer for the following setting:
 - a) RBW : 100 kHz (< 1 GHz), 1 MHz (> 1 GHz).
 - b) VBW : 300 kHz (< 1 GHz), 3 MHz (> 1 GHz).
 - c) Detector mode : Positive Peak
- 3 The transmitter was placed on a wooden turntable, and it was transmitting into non-radiating load which was also placed on the turntable.
- 4 The measurement antenna was placed at a distance of 3 meters from the EUT. During the tests, the antenna height and polarization as well as EUT azimuth were varied in order to identify the maximum level of emissions from the EUT. The test was performed by placing the EUT on 3-orthogonal axis.
- 5 The frequency range up to tenth harmonic of the fundamental frequency was investigated.
- 6 Remove the EUT and replace it with substitution antenna. A signal generator was connected to the substitution antenna by a non-radiating cable. The absolute levels of the spurious emissions were measured by the substitution.
- 7 Spurious emissions in dB = 10 Log (TX power in Watts/0.001) – the absolute level

Measuring Equipments

No.	Equipment	Manufacture	Model No.	Serial No.	Cal Date	Cal Exp.
1	Attenuator(10dB)	HUBER+SUHNER	6810.17B	5061	May. 23, 16	May. 31, 17
2	Dummy Load	TME	CT-150NP	1138693	Mar. 03, 16	Mar. 31, 17
3	Signal Generator	Rohde&Schwarz	SMP02	845275/007	May. 10, 16	May. 31, 17
4	Spectrum Analyzer	Agilent	N9030A	US51350220	Dec. 02, 15	Dec. 31, 16
5	D.R.G Antenna	Schwarzbeck	3115	5044	Jul. 31, 15	Jul. 31, 16
6	D.R.G Antenna	ETS LINDGREN	3117	00055157	May. 30, 16	May. 31, 17
7	Dipole Antenna(TX)	Schwarzbeck	UHA9105	AM0082002	Jul. 21, 15	Jul. 31, 16
8	Dipole Antenna(TX)	Schwarzbeck	VHA9103	C01082007	Jul. 21, 15	Jul. 31, 16
9	Tri-log Antenna(RX)	Schwarzbeck	VULB9168WP	288	Jan. 05, 16	Jan. 31, 17
10	DC Power Supply	Daiichi denpa kogyo	GZV4000	90290931	None	None
11	Digital Multi Meter	FLUKE	8846A	9642018	Jul. 10, 15	Jul. 31, 16
12	Amplifier	TOYO	TPA0118-30	0402	Mar. 09, 16	Mar. 31, 17
13	Attenuator	HUBER + SUHNER	6803.17.B	5111	Mar. 09, 16	Mar. 31, 17
14	Amplifier	Intertek Japan	ZX60-3018G	005	Feb. 01, 16	Feb. 28, 17
15	Attenuator	TAMAGAWA	CFA-01	A00040805	Feb. 01, 16	Feb. 28, 17
16	RF Switch	Intertek Japan	ACX-150-1	A12301501	Feb. 01, 16	Feb. 28, 17

Measuring Cables

No.	Cable	Manufacturer	Model No.	Serial No.	Cal Date	Cal Exp.
R11	Coaxial Cable	FUJIKURA	5D-2W	R11	Jan. 06, 16	Jan. 31, 17
R1	Coaxial Cable	FUJIKURA	5D-2W	R1	Jan. 06, 16	Jan. 31, 17
R3	Coaxial Cable	FUJIKURA	10D-2W	R3	Jan. 06, 16	Jan. 31, 17
R5	Coaxial Cable	FUJIKURA	RG-5A/U	R5	Jan. 06, 16	Jan. 31, 17
R7	Coaxial Cable	FUJIKURA	RG-5A/U	R7	Jan. 06, 16	Jan. 31, 17
R10	Coaxial Cable	FUJIKURA	5D-2W	R10	Jan. 06, 16	Jan. 31, 17
G1	Coaxial Cable	SUHNER	SUCOFLEX 104	229603	Mar. 09, 16	Mar. 31, 17
G2	Coaxial Cable	Candox	5B-048-98-98-5000	111130	Mar. 09, 16	Mar. 31, 17
W13	Coaxial Cable	Suhner	SUCOFLEX106	KSR00207	May. 23, 16	May. 31, 17

Measuring Equipment Configuration

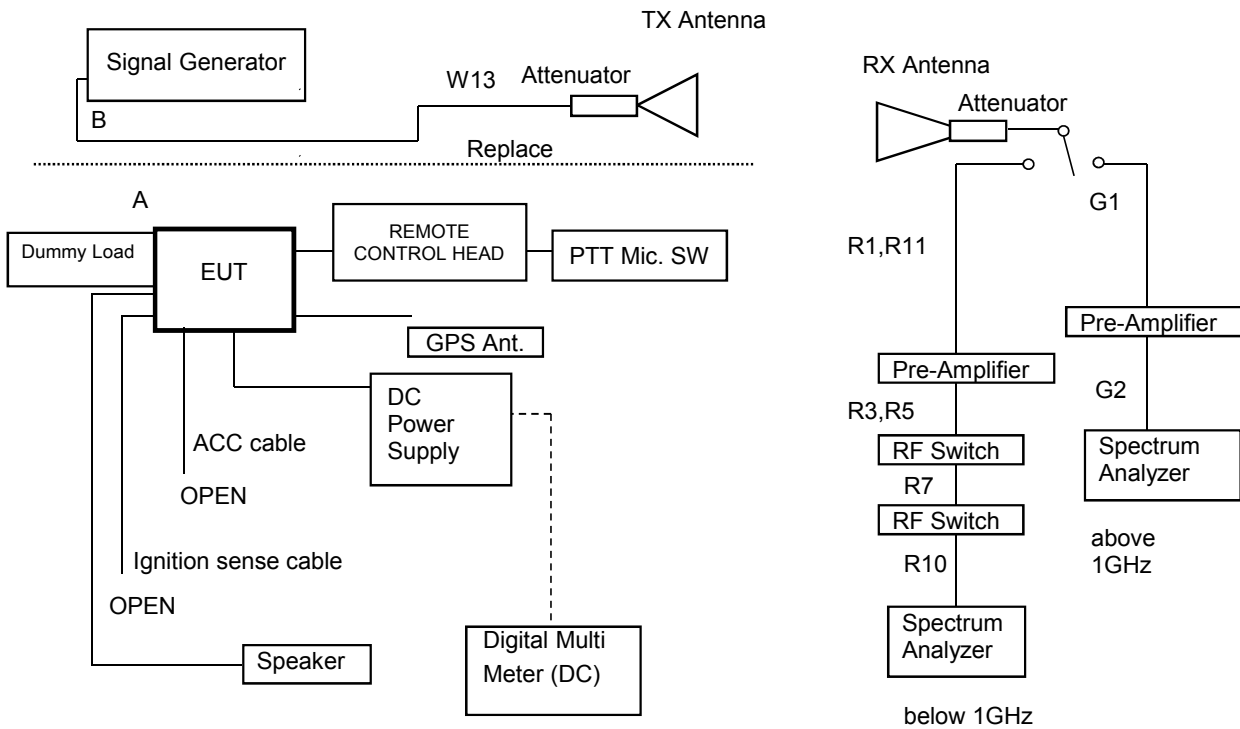

Test Results

Test date	Jun 28, 2016 to Jul 07, 2016
Location	Kashima No.12 Test Site
temperature	21 to 25 [degree C]
Humidity Variation	50 to 60 [%]
Atmospheric Pressure	101.0 to 102.3 [kPa]
Test Engineer	Koichi Wagatsuma

Test was carried out for all the frequency band of section 10.1
 State the worst case (below).

State : High Power / Authorized Bandwidth 11.25 kHz / 815.05MHz(Band3)

No	Frequency (MHz)	Pol	Reading Level (dBm)	SG Out Level (dBm)	Antenna Gain (dBd)	Loss (dB)	Correct Level (dBm)	Emission Level (dBc)	MASK D Limit Level (dBc)	Margin (dB)
1	1630.10	Hor.	-52.42	-38.80	6.22	13.18	-45.8	-91.2	-65.4	25.8
		Ver.	-52.00	-36.32	6.22	13.18	-43.3	-88.7	-65.4	23.3
2	2445.15	Hor.	-	-	7.49	13.98	-	-	-65.4	-
		Ver.	-	-	7.49	13.98	-	-	-65.4	-
3	3260.20	Hor.	-60.32	-40.83	7.71	14.65	-47.8	-93.2	-65.4	27.8
		Ver.	-60.62	-39.88	7.71	14.65	-46.8	-92.3	-65.4	26.9
4	4075.25	Hor.	-	-	7.82	15.21	-	-	-65.4	-
		Ver.	-	-	7.82	15.21	-	-	-65.4	-
5	4890.30	Hor.	-	-	8.80	15.74	-	-	-65.4	-
		Ver.	-	-	8.80	15.74	-	-	-65.4	-
6	5705.35	Hor.	-	-	8.89	16.24	-	-	-65.4	-
		Ver.	-	-	8.89	16.24	-	-	-65.4	-
7	6520.40	Hor.	-	-	9.88	16.75	-	-	-65.4	-
		Ver.	-	-	9.88	16.75	-	-	-65.4	-
8	7335.45	Hor.	-	-	8.97	17.25	-	-	-65.4	-
		Ver.	-	-	8.97	17.25	-	-	-65.4	-
9	8150.50	Hor.	-	-	9.44	17.70	-	-	-65.4	-
		Ver.	-	-	9.44	17.70	-	-	-65.4	-

There is the margin of 20dB over except for the above points.

Mask D Limit (dBc) = whichever is the lesser attenuation ; $-(50+10\log(P))$ or -70
 Correct Level (dBm) = Substitute SG Level (dBm) + ANT Gain (dBd) - Loss (Cable, Attenuator) (dB)
 Emission Level (dBc) = Correct Level (dBm) - $10\log(P*1000)$
 P = Carrier Level (W)
 " - " = Measurement Limit

State : Low Power / Authorized Bandwidth 11.25 kHz / 815.05MHz(Band3)

No	Frequency (MHz)	Pol	Reading Level (dBm)	SG Out Level (dBm)	Antenna Gain (dBd)	Loss (dB)	Correct Level (dBm)	Emission Level (dBc)	MASK D Limit Level (dBc)	Margin (dB)
1	1630.10	Hor.	-56.54	-42.91	6.22	13.18	-49.9	-82.9	-53.0	29.9
		Ver.	-58.21	-42.53	6.22	13.18	-49.5	-82.5	-53.0	29.5
2	2445.15	Hor.	-	-	7.49	13.98	-	-	-53.0	-
		Ver.	-	-	7.49	13.98	-	-	-53.0	-
3	3260.20	Hor.	-	-	7.71	14.65	-	-	-53.0	-
		Ver.	-	-	7.71	14.65	-	-	-53.0	-
4	4075.25	Hor.	-	-	7.82	15.21	-	-	-53.0	-
		Ver.	-	-	7.82	15.21	-	-	-53.0	-
5	4890.30	Hor.	-	-	8.80	15.74	-	-	-53.0	-
		Ver.	-	-	8.80	15.74	-	-	-53.0	-
6	5705.35	Hor.	-	-	8.89	16.24	-	-	-53.0	-
		Ver.	-	-	8.89	16.24	-	-	-53.0	-
7	6520.40	Hor.	-	-	9.88	16.75	-	-	-53.0	-
		Ver.	-	-	9.88	16.75	-	-	-53.0	-
8	7335.45	Hor.	-	-	8.97	17.25	-	-	-53.0	-
		Ver.	-	-	8.97	17.25	-	-	-53.0	-
9	8150.50	Hor.	-	-	9.44	17.70	-	-	-53.0	-
		Ver.	-	-	9.44	17.70	-	-	-53.0	-

There is the margin of 20dB over except for the above points.

Mask D Limit (dBc) = whichever is the lesser attenuation ; $-(50+10\log(P))$ or -70

Correct Level (dBm) = Substitute SG Level (dBm) + ANT Gain (dBd) - Loss (Cable, Attenuator) (dB)

Emission Level (dBc) = Correct Level (dBm) - $10\log(P*1000)$

P = Carrier Level (W)

" - " = Measurement Limit

State : High Power / Authorized Bandwidth 11.25 kHz / 851.05MHz(Band4)

No	Frequency (MHz)	Pol	Reading Level (dBm)	SG Out Level (dBm)	Antenna Gain (dBd)	Loss (dB)	Correct Level (dBm)	Emission Level (dBc)	MASK D Limit Level (dBc)	Margin (dB)
1	1702.10	Hor.	-58.63	-43.84	6.30	13.26	-50.8	-96.2	-65.4	30.8
		Ver.	-56.02	-39.45	6.30	13.26	-46.4	-91.9	-65.4	26.5
2	2553.15	Hor.	-61.36	-43.27	7.60	14.08	-49.8	-95.2	-65.4	29.8
		Ver.	-60.68	-40.83	7.60	14.08	-47.3	-92.8	-65.4	27.4
3	3404.20	Hor.	-62.14	-42.51	7.81	14.75	-49.4	-94.9	-65.4	29.5
		Ver.	-61.46	-40.88	7.81	14.75	-47.8	-93.3	-65.4	27.9
4	4255.25	Hor.	-	-	8.26	15.33	-	-	-65.4	-
		Ver.	-	-	8.26	15.33	-	-	-65.4	-
5	5106.30	Hor.	-	-	8.76	15.87	-	-	-65.4	-
		Ver.	-	-	8.76	15.87	-	-	-65.4	-
6	5957.35	Hor.	-	-	9.17	16.39	-	-	-65.4	-
		Ver.	-	-	9.17	16.39	-	-	-65.4	-
7	6808.40	Hor.	-	-	9.40	16.93	-	-	-65.4	-
		Ver.	-	-	9.40	16.93	-	-	-65.4	-
8	7659.45	Hor.	-	-	9.42	17.44	-	-	-65.4	-
		Ver.	-	-	9.42	17.44	-	-	-65.4	-
9	8510.50	Hor.	-	-	9.22	17.82	-	-	-65.4	-
		Ver.	-	-	9.22	17.82	-	-	-65.4	-

There is the margin of 20dB over except for the above points.

Mask D Limit (dBc) = whichever is the lesser attenuation ; $-(50+10\log(P))$ or -70

Correct Level (dBm) = Substitute SG Level (dBm) + ANT Gain (dBd) - Loss (Cable, Attenuator) (dB)

Emission Level (dBc) = Correct Level (dBm) - $10\log(P*1000)$

P = Carrier Level (W)

" - " = Measurement Limit

State : Low Power / Authorized Bandwidth 11.25 kHz / 868.95MHz(Band4)

No	Frequency (MHz)	Pol	Reading Level (dBm)	SG Out Level (dBm)	Antenna Gain (dBd)	Loss (dB)	Correct Level (dBm)	Emission Level (dBc)	MASK D Limit Level (dBc)	Margin (dB)
1	1737.90	Hor.	-62.53	-46.92	6.33	13.30	-53.9	-86.9	-53.0	33.9
		Ver.	-61.09	-44.41	6.33	13.30	-51.4	-84.4	-53.0	31.4
2	2606.85	Hor.	-	-	7.60	14.13	-	-	-53.0	-
		Ver.	-	-	7.60	14.13	-	-	-53.0	-
3	3475.80	Hor.	-	-	7.85	14.80	-	-	-53.0	-
		Ver.	-	-	7.85	14.80	-	-	-53.0	-
4	4344.75	Hor.	-	-	8.48	15.39	-	-	-53.0	-
		Ver.	-	-	8.48	15.39	-	-	-53.0	-
5	5213.70	Hor.	-	-	8.73	15.94	-	-	-53.0	-
		Ver.	-	-	8.73	15.94	-	-	-53.0	-
6	6082.65	Hor.	-	-	9.33	16.47	-	-	-53.0	-
		Ver.	-	-	9.33	16.47	-	-	-53.0	-
7	6951.60	Hor.	-	-	9.57	17.02	-	-	-53.0	-
		Ver.	-	-	9.57	17.02	-	-	-53.0	-
8	7820.55	Hor.	-	-	9.43	17.54	-	-	-53.0	-
		Ver.	-	-	9.43	17.54	-	-	-53.0	-
9	8689.50	Hor.	-	-	9.15	17.89	-	-	-53.0	-
		Ver.	-	-	9.15	17.89	-	-	-53.0	-

There is the margin of 20dB over except for the above points.

Mask D Limit (dBc) = whichever is the lesser attenuation ; $-(50+10\log(P))$ or -70

Correct Level (dBm) = Substitute SG Level (dBm) + ANT Gain (dBd) - Loss (Cable, Attenuator) (dB)

Emission Level (dBc) = Correct Level (dBm) - $10\log(P*1000)$

P = Carrier Level (W)

" - " = Measurement Limit

7.4 Emission Masks (Occupied Bandwidth)

REGULATIONS	: FCC Part 2 Section 1049 (c) (1), Part 90 Section 210 / RSS-119 Section 5.5
TEST METHOD/GUIDE	: ANSI/TIA-603-D Section 2.2.11.2 / RSS-119 Section 5.5

Test Procedure

- 1 The EUT and test equipment were set up as shown on the following page.
- 2 For EUT supporting audio modulation, the audio signal generator was adjusted to the frequency of maximum response and with output level set for +/- 2.5 kHz deviation (or 50 % modulation). (FM modulation).
- 3 With level constant, the signal level was increased 16 dB.
- 4 For EUT supporting digital modulation, the digital modulation mode was operated to its maximum extent.
- 5 Adjust the spectrum analyzer for the following setting:
 - a) RBW : 100 Hz (Modulation , Authorized Band:11.25 kHz)
 - b) VBW : 10times the RBW (Modulation , Authorized Band 11.25 kHz).
 - c) RBW and VBW : 30 kHz (Non Modulation / Digital Modulation).
- 6 The occupied Bandwidth was measured with the Spectrum Analyzer controls set as shown on the test results.

The selection of Emission Mask

Emission Designation : 7K60FXE/FXD

No.	Frequency	Audio Filter	Channel Bandwidth (kHz)	Authorized Bandwidth (kHz)	Selection of Emission Mask	
	(MHz)				FCC	IC
1	806.05 (FCC/RSS)	Without	12.5	11.25	H	D
2	815.05 (FCC/RSS)	Without	12.5	11.25	G	D
3	823.95 (FCC/RSS)	Without	12.5	11.25	G	D
4	851.05 (FCC/RSS)	Without	12.5	11.25	H	D
5	860.05 (FCC/RSS)	Without	12.5	11.25	G	D
6	868.95 (FCC/RSS)	Without	12.5	11.25	G	D

Measuring Equipments

No.	Equipment	Manufacture	Model No.	Serial No.	Cal Date	Cal Exp.
1	Attenuator (20dB)	Aeroflex/Wenshel	66-20-34	BY4357	May. 23, 16	May. 31, 17
2	Attenuator (30dB)	Weinschel	WA-29-30-34	8923	May. 23, 16	May. 31, 17
3	Spectrum Analyzer	Agilent	N9030A	US51350220	Dec. 02, 15	Dec. 31, 16
4	DC Power Supply	Daiichi denpa kogyo	GZV4000	90290931	None	None
5	Digital Multi Meter	FLUKE	8846A	9642018	Jul. 10, 15	Jul. 31, 16

Measuring Cables

No.	Cable	Manufacture	Model No.	Serial No.	Cal Date	Cal Exp.
W2	Coaxial Cable	Suhner	SUCOFLEX104	F0000017	Jan. 15, 16	Jan. 31, 17

Measuring Equipment Configuration

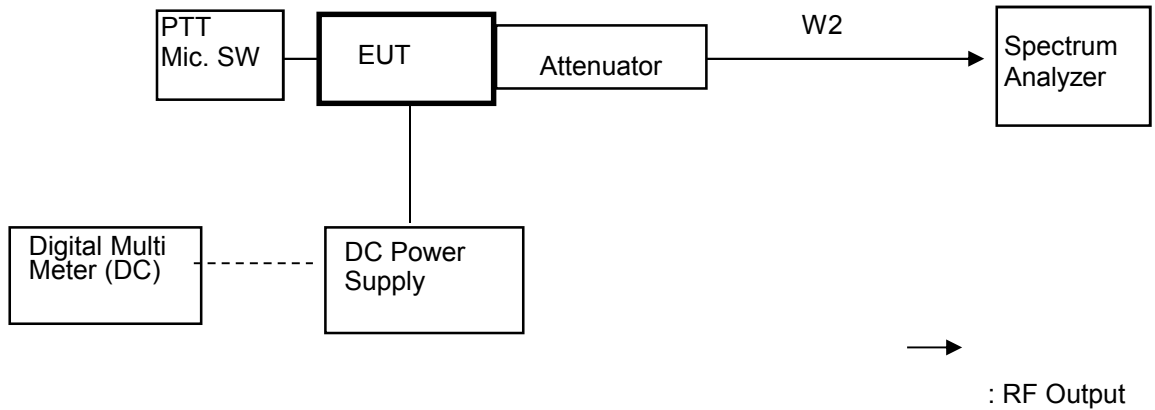

Test Results

Test date	Jul 14, 2016
Location	Kashima No.1 Test Site
temperature	20 [degree C]
Humidity Variation	60 [%]
Atmospheric Pressure	101.6 [kPa]
Test Engineer	Koichi Wagatsuma

Test was carried out for all the frequency band of section 10.1
 State the worst case (below).

State : High Power / Authorized Bandwidth 11.25 kHz/ 7K60FXE / FXD / 806.05 MHz(FCC) (Band 3)
 Limit : Mask H

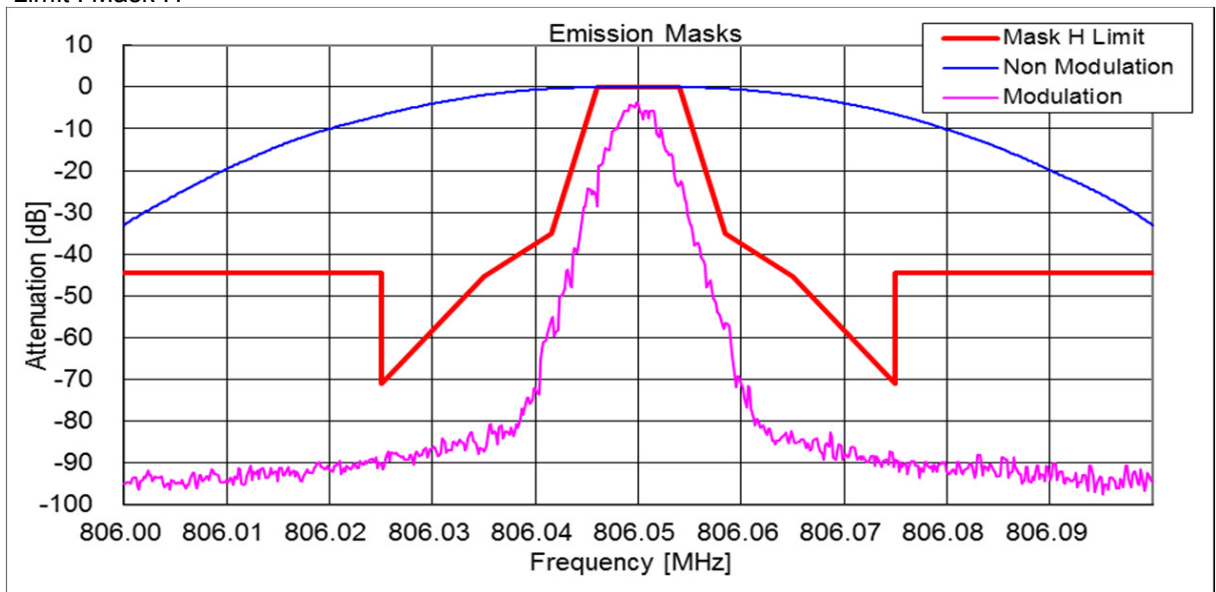

State : High Power / Authorized Bandwidth 11.25 kHz/ 7K60FXE / FXD / 823.95 MHz(FCC) (Band 3)
Limit : Mask G

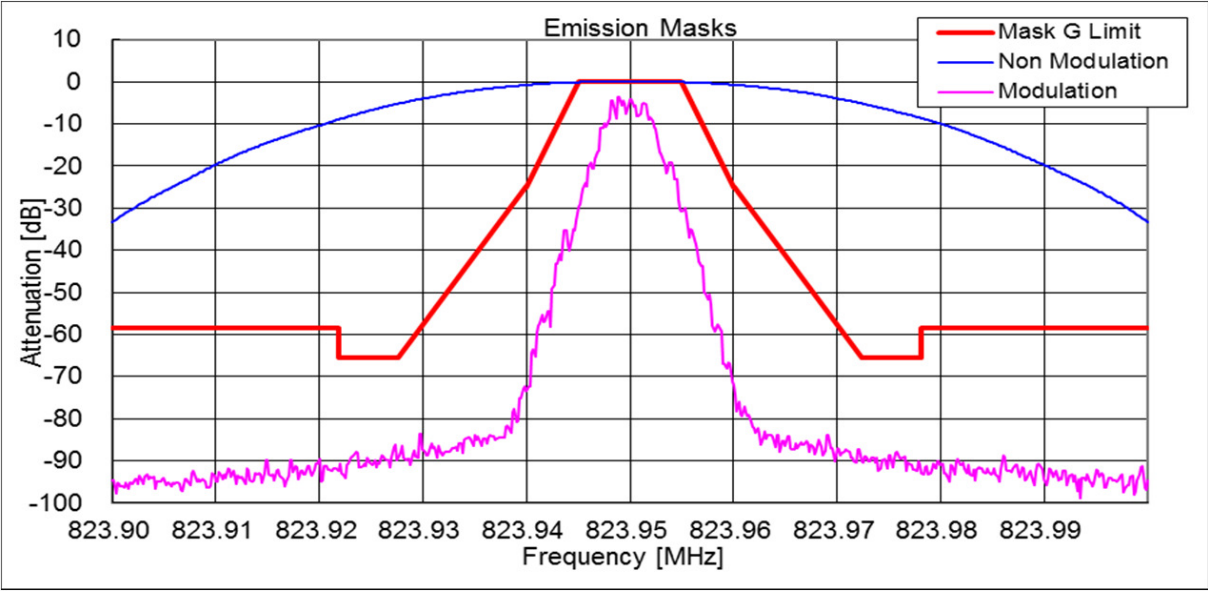

State : High Power / Authorized Bandwidth 11.25 kHz/ 7K60FXE / FXD / 815.05 MHz(RSS) (Band 3)
Limit : Mask D

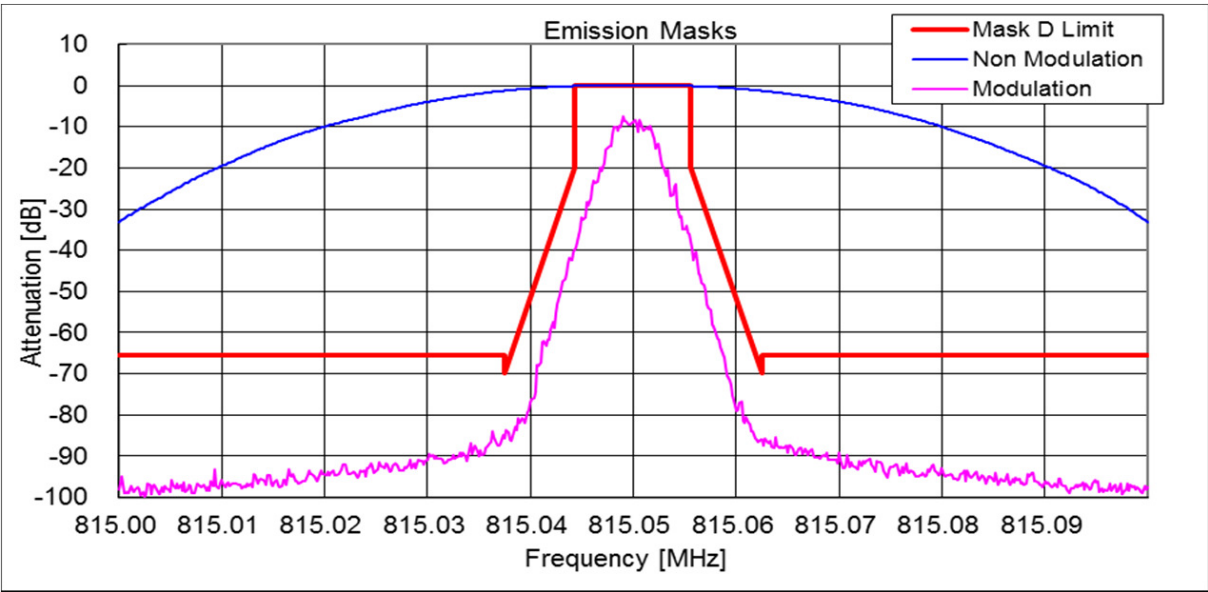

State : High Power / Authorized Bandwidth 11.25 kHz/ 7K60FXE / FXD / 851.05 MHz(FCC) (Band 4)
Limit : Mask H

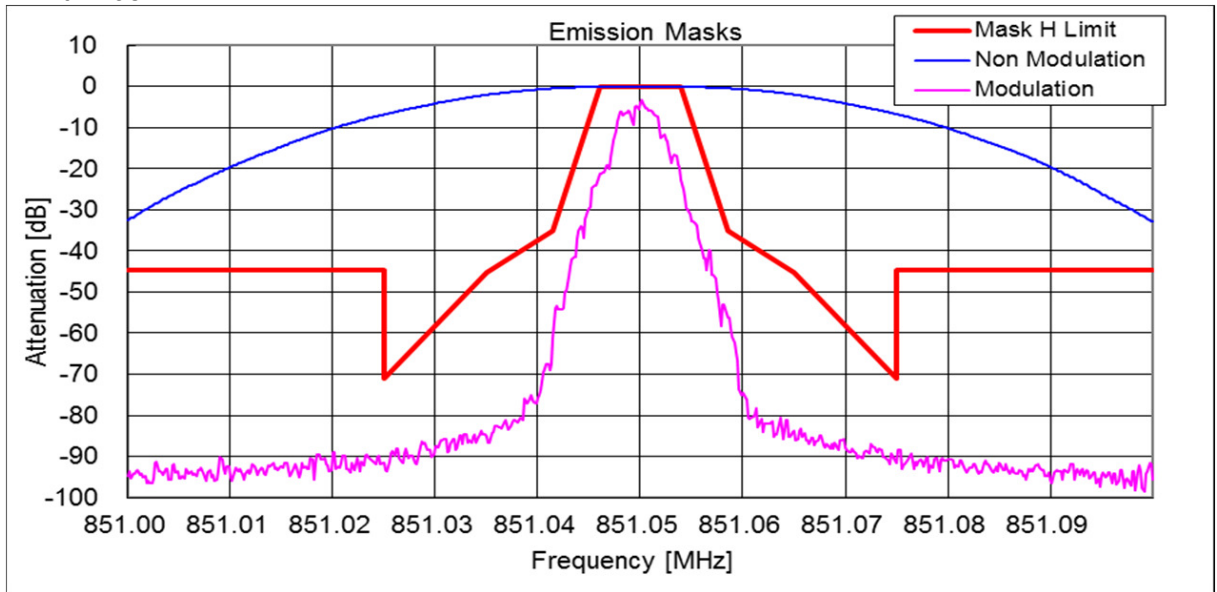

State : High Power / Authorized Bandwidth 11.25 kHz/ 7K60FXE / FXD / 860.05 MHz(FCC) (Band 4)
Limit : Mask G

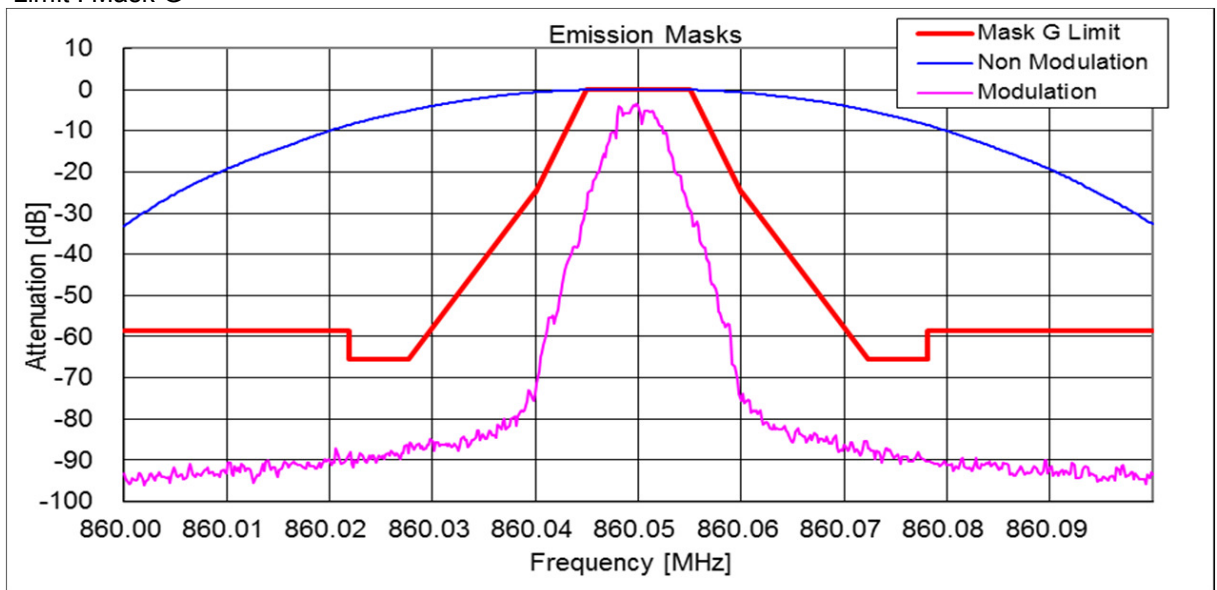

State : High Power / Authorized Bandwidth 11.25 kHz/ 7K60FXE / FXD / 823.95 MHz(RSS) (Band 4)
Limit : Mask D

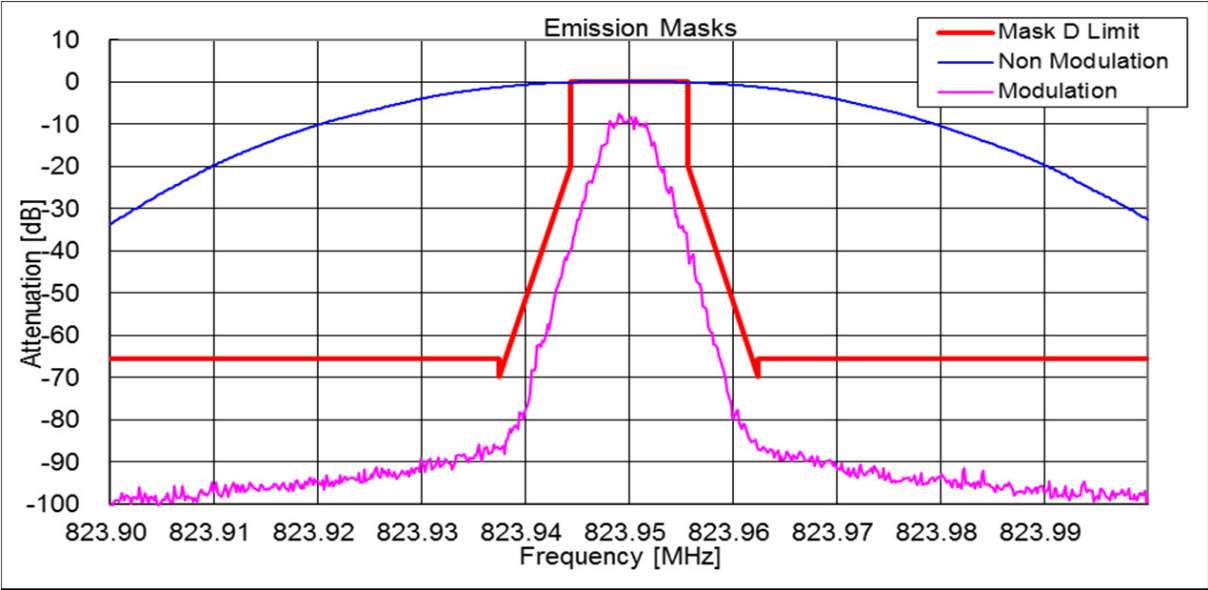

State : Low Power / Authorized Bandwidth 11.25 kHz/ 7K60FXE / FXD / 806.05 MHz(FCC) (Band 3)
Limit : Mask H

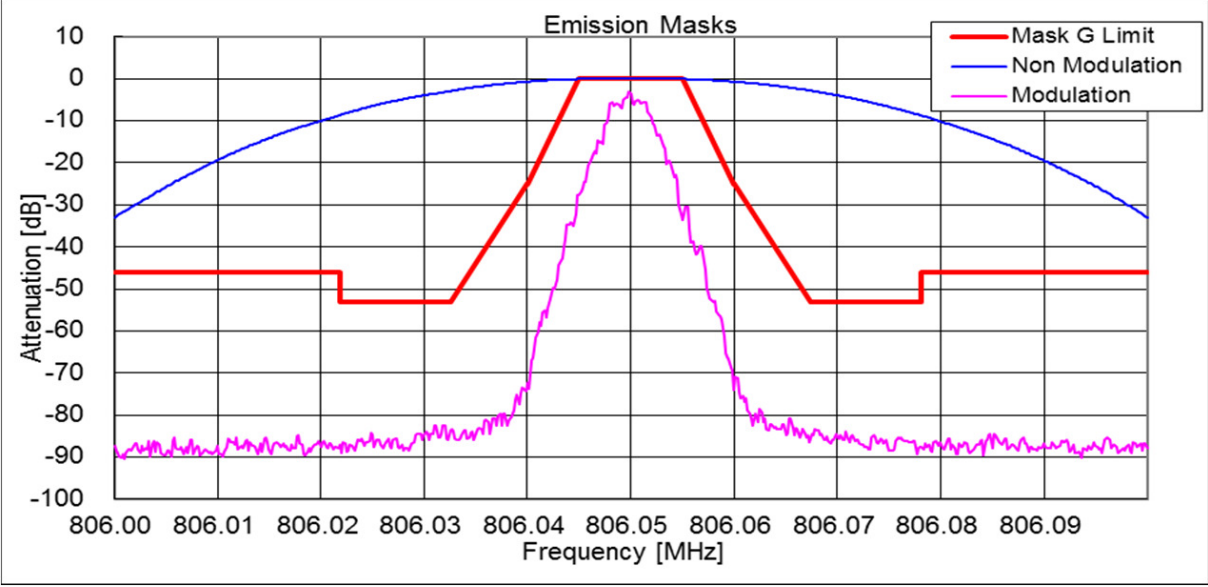

State : Low Power / Authorized Bandwidth 11.25 kHz/ 7K60FXE / FXD / 823.95 MHz(FCC) (Band 3)
Limit : Mask G

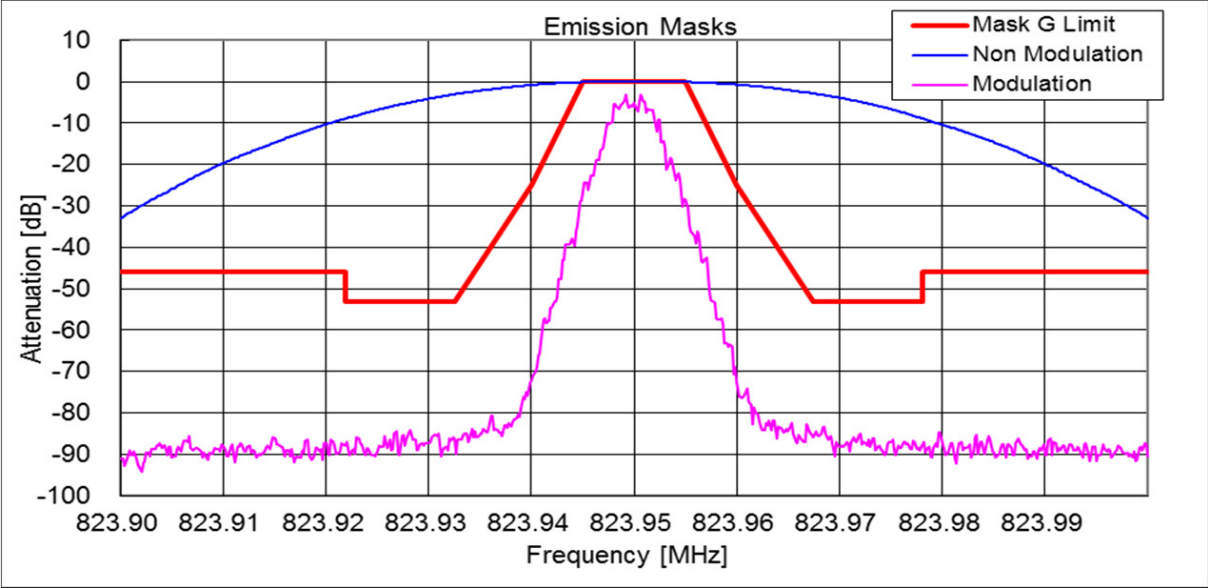

State : Low Power / Authorized Bandwidth 11.25 kHz/ 7K60FXE / FXD / 806.05 MHz(RSS) (Band 3)
Limit : Mask D

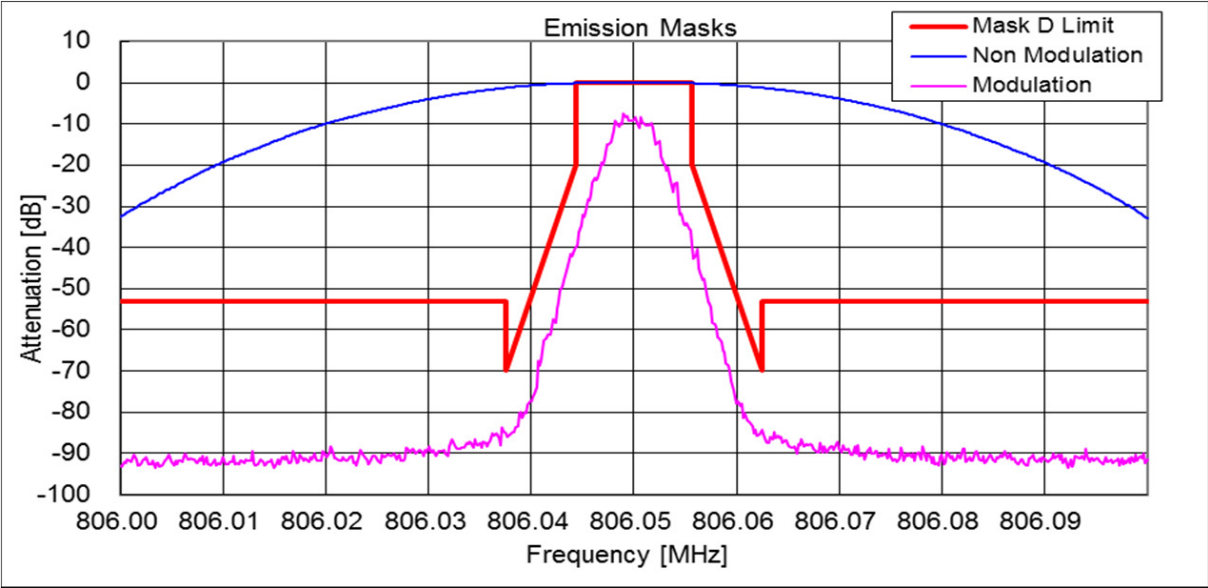

State : Low Power / Authorized Bandwidth 11.25 kHz/ 7K60FXE / FXD / 851.05 MHz(FCC) (Band 4)
Limit : Mask H

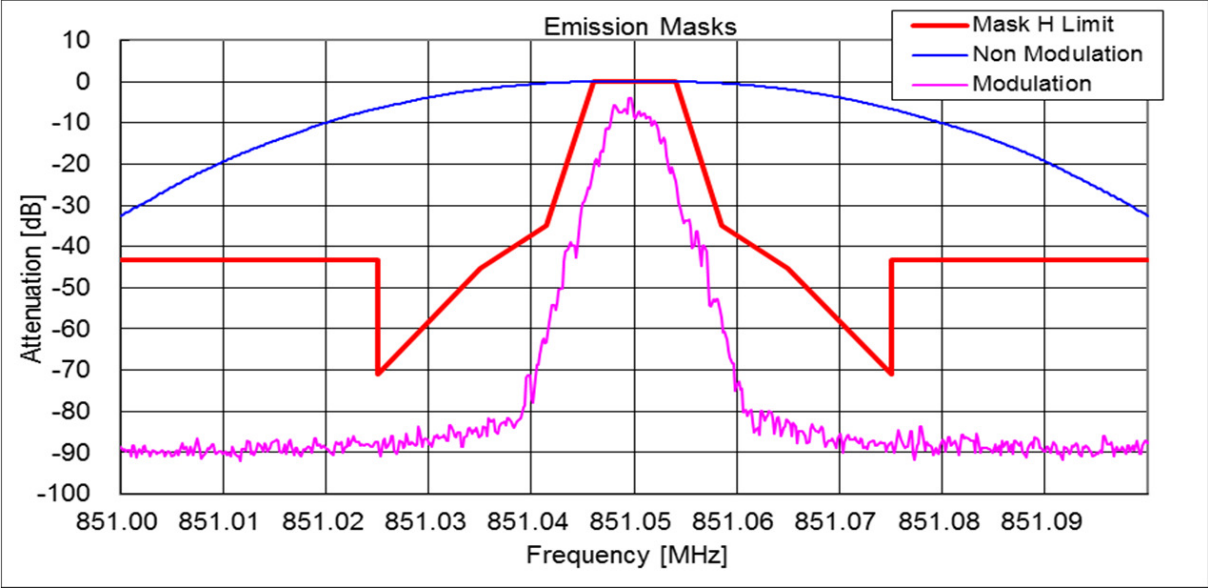

State : Low Power / Authorized Bandwidth 11.25 kHz/ 7K60FXE / FXD / 868.95 MHz(FCC) (Band 4)
Limit : Mask G

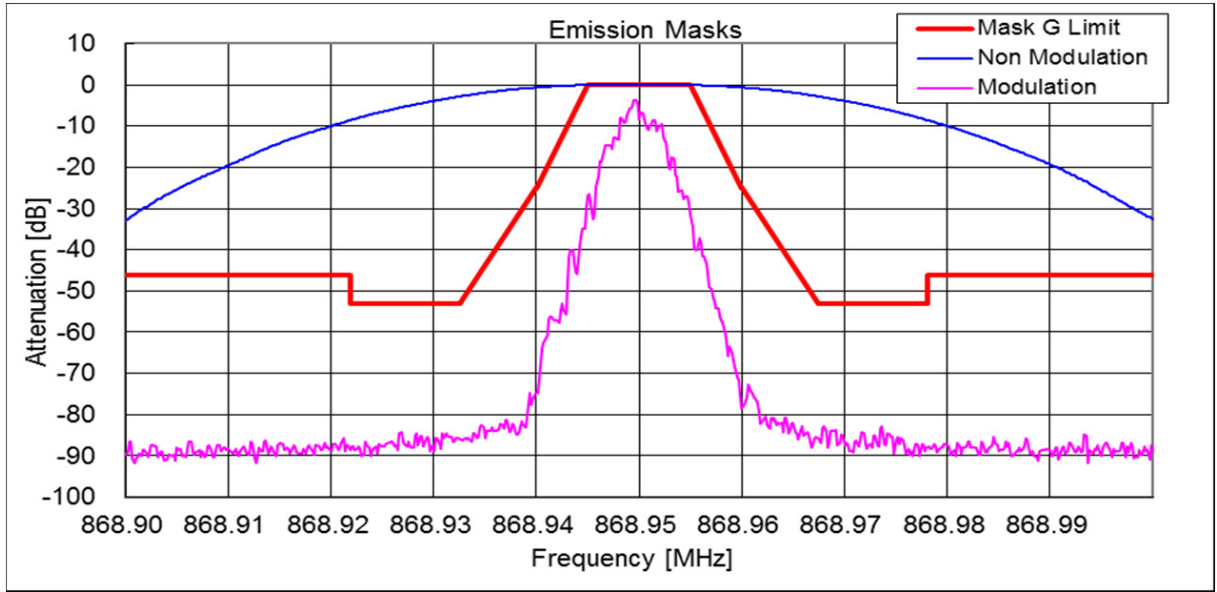

State : Low Power / Authorized Bandwidth 11.25 kHz/ 7K60FXE / FXD / 860.05 MHz(RSS) (Band 4)
Limit : Mask D

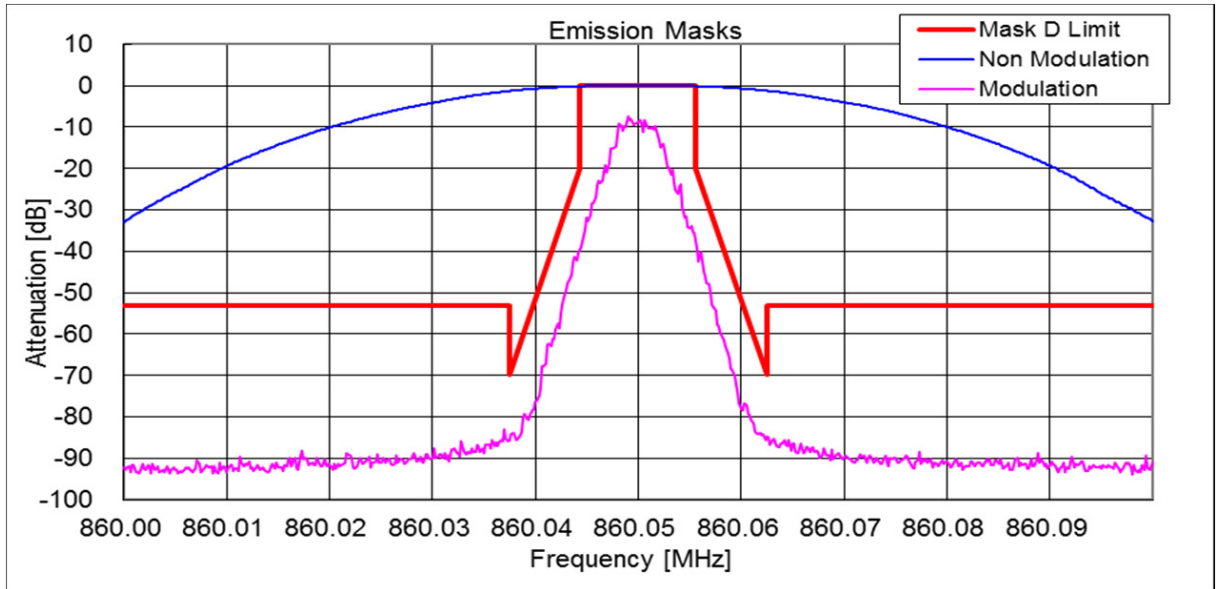

7.5 Emission Limitations

REGULATIONS	: 47 CFR 2.1049, 90.543 / RSS-119 Section 5.8
TEST METHOD/GUIDE	: ANSI/TIA-603-C Section 2.2.14 ANSI/TIA-102-CAAA-A Section 2.2.8 / RSS-119 Section 4.3

7.5.1

Test Procedure

§ 90.543 (c) : Out-of-band emission limit :Conducted

- 1 The EUT and test equipment were set up as shown on the following page.
- 2 The modulation mode was operated to its maximum extent (CW mode)
- 3 Adjust the spectrum analyzer for the following setting:
 - a) RBW : 100 kHz (< 1 GHz), 1 MHz (> 1 GHz).
 - b) VBW : 300 kHz (< 1 GHz), 3 MHz (> 1 GHz).
 - c) Sweep Speed : 50ms
 - d) Detector mode : Average power
- 4 The emissions were measured for the worst case as follows:
 - a) : within a band of frequencies defined by the carrier frequency plus and minus one channel.
 - b) : from the lowest frequency generated in the EUT and to at least the 10th harmonic of the carrier frequency, or 40 GHz, whichever is lower.

Measuring Equipments

No.	Equipment	Manufacture	Model No.	Serial No.	Cal Date	Cal Exp.
1	Attenuator (20dB)	Aeroflex/Wenshel	66-20-34	BY4357	May. 23, 16	May. 31, 17
2	Attenuator (30dB)	Weinschel	WA-29-30-34	8923	May. 23, 16	May. 31, 17
3	Highpass Filter	TME	UHP-127	1511798E	May. 19, 16	May. 31, 17
4	Signal Generator	Rohde&Schwarz	SMB 100A	105709	Apr. 01, 16	Apr. 30, 17
5	Spectrum Analyzer	Agilent	N9030A	US51350220	Dec. 02, 15	Dec. 31, 16
6	DC Power Supply	Daiichi denpa kogyo	GZV4000	90290931	None	None
7	Digital Multi Meter	FLUKE	8846A	9642018	Jul. 10, 15	Jul. 31, 16

Measuring Cables

No.	Cable	Manufacture	Model No.	Serial No.	Cal Date	Cal Exp.
W2	Coaxial Cable	Suhner	SUCOFLEX104	F0000018	Jan. 16, 16	Jan. 31, 17

Measuring Equipment Configuration

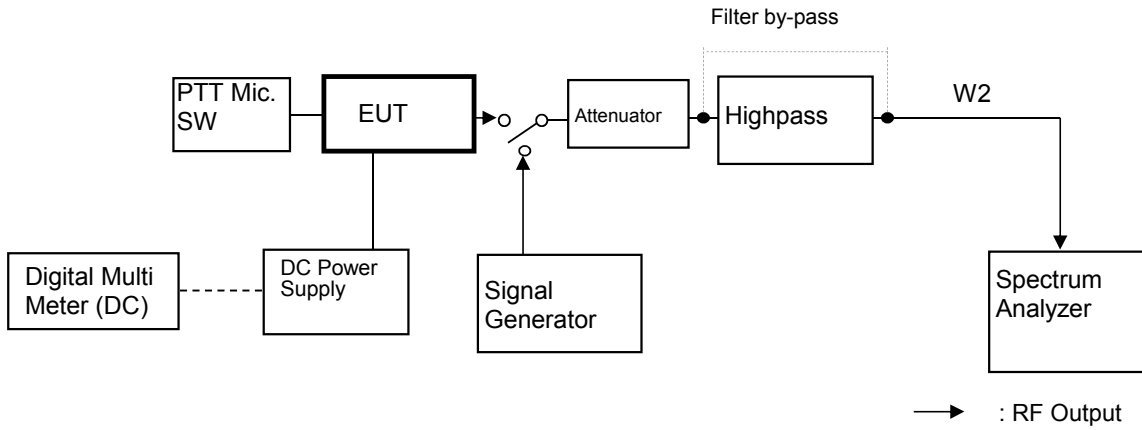

Test Results

Test date	Jul 13, 2016	
Location	Kashima No.1 Test Site	
temperature	24.7	[degree C]
Humidity Variation	62	[%]
Atmospheric Pressure	99.8	[kPa]
Test Engineer	Koichi Wagatsuma	

Test was carried out for all the frequency band of section 10.1
 State the worst case(below)

State: High Power / Authorized Bandwidth 20 kHz

No.	Tuned Frequency (MHz)	Band	Spurious Frequency (MHz)	Correct Level (dBm)	Emission Level (dBc)	Limit (dBc)	Margin (dB)
1	769.05 (Band 1)	Low	1538.10	-45.47	-90.24	-57.8	32.4
2	774.95 (Band 1)	High	1549.90	-45.20	-89.97	-57.8	32.2
4	799.05 (Band 2)	Low	1598.10	-45.48	-90.25	-57.8	32.5
3	804.95 (Band 2)	High	1609.90	-44.73	-89.50	-57.8	31.7

There is the margin of 20dB over except for the above points.

State: Low Power / Authorized Bandwidth 20 kHz

No.	Tuned Frequency (MHz)	Band	Spurious Frequency (MHz)	Correct Level (dBm)	Emission Level (dBc)	Limit (dBc)	Margin (dB)
1	769.05 (Band 1)	Low	No Point detected	-	-	-46.0	-
2	774.95 (Band 1)	High	No Point detected	-	-	-46.0	-
3	799.05 (Band 2)	Low	No Point detected	-	-	-46.0	-
4	804.95 (Band 2)	High	No Point detected	-	-	-46.0	-

There is the margin of 20dB over except for the above points.

§ 90.543 (c) Limit (dBc) = $-(43+10\log(P))$

Correct Level (dBm) = Substitute SG Level (dBm)

Emission Level (dBc) = Correct Level (dBm) - $10\log(P*1000)$

P = Carrier Level (W)

" - " = Measurement Limit

7.5.2

Test Procedure

§ 90.543 (c) : Out-of-band emission limit : Radiated

- 1 The EUT and test equipment were set up as shown on the following page.
- 2 Adjust the spectrum analyzer for the following setting:
 - a) RBW : 100 kHz (< 1 GHz), 1 MHz (> 1 GHz).
 - b) VBW : 300 kHz (< 1 GHz), 3 MHz (> 1 GHz).
 - c) Sweep Speed : 50ms.
 - d) Detector mode : Positive Peak
- 3 The transmitter was placed on a wooden turntable, and it was transmitting into non-radiating load which was also placed on the turntable.
- 4 The measurement antenna was placed at a distance of 3 meters from the EUT.
During the tests, the antenna height and polarization as well as EUT azimuth were varied in order to identify the maximum level of emissions from the EUT.
The test was performed by placing the EUT on 3-orthogonal axis.
- 5 The frequency range up to tenth harmonic of the fundamental frequency was investigated.
- 6 Remove the EUT and replace it with substitution antenna. A signal generator was connected to the substitution antenna by a non-radiating cable.
The absolute levels of the spurious emissions were measured by the substitution.
- 7 Spurious emissions in dB = 10 Log (TX power in Watts/0.001) – the absolute level

Measuring Equipments

No.	Equipment	Manufacture	Model No.	Serial No.	Cal Date	Cal Exp.
1	Attenuator(10dB)	HUBER+SUHNER	6810.17B	5061	May. 23, 16	May. 31, 17
2	Dummy Load	TME	CT-150NP	1138693	Mar. 03, 16	Mar. 31, 17
3	Signal Generator	Rohde&Schwarz	SMP02	845275/007	May. 10, 16	May. 31, 17
4	Spectrum Analyzer	Agilent	N9030A	US51350220	Dec. 02, 15	Dec. 31, 16
5	D.R.G Antenna	Schwarzbeck	3115	5044	Jul. 31, 15	Jul. 31, 16
6	D.R.G Antenna	ETS LINDGREN	3117	00055157	May. 30, 16	May. 31, 17
7	Dipole Antenna(TX)	Schwarzbeck	UHA9105	AM0082002	Jul. 21, 15	Jul. 31, 16
8	Dipole Antenna(TX)	Schwarzbeck	VHA9103	C01082007	Jul. 21, 15	Jul. 31, 16
9	Tri-log Antenna(RX)	Schwarzbeck	VULB9168WP	288	Jan. 05, 16	Jan. 31, 17
10	DC Power Supply	Daiichi denpa kogyo	GZV4000	90290931	None	None
11	Digital Multi Meter	FLUKE	8846A	9642018	Jul. 10, 15	Jul. 31, 16
12	Amplifier	TOYO	TPA0118-30	0402	Mar. 09, 16	Mar. 31, 17
13	Attenuator	HUBER + SUHNER	6803.17.B	5111	Mar. 09, 16	Mar. 31, 17
14	Amplifier	Intertek Japan	ZX60-3018G	005	Feb. 01, 16	Feb. 28, 17
15	Attenuator	TAMAGAWA	CFA-01	A00040805	Feb. 01, 16	Feb. 28, 17
16	RF Switch	Intertek Japan	ACX-150-1	A12301501	Feb. 01, 16	Feb. 28, 17

Measuring Cables

No.	Cable	Manufacture	Model No.	Serial No.	Cal Date	Cal Exp.
R11	Coaxial Cable	FUJIKURA	5D-2W	R11	Jan. 06, 16	Jan. 31, 17
R1	Coaxial Cable	FUJIKURA	5D-2W	R1	Jan. 06, 16	Jan. 31, 17
R3	Coaxial Cable	FUJIKURA	10D-2W	R3	Jan. 06, 16	Jan. 31, 17
R5	Coaxial Cable	FUJIKURA	RG-5A/U	R5	Jan. 06, 16	Jan. 31, 17
R7	Coaxial Cable	FUJIKURA	RG-5A/U	R7	Jan. 06, 16	Jan. 31, 17
R10	Coaxial Cable	FUJIKURA	5D-2W	R10	Jan. 06, 16	Jan. 31, 17
G1	Coaxial Cable	SUHNER	SUCOFLEX 104	229603	Mar. 09, 16	Mar. 31, 17
G2	Coaxial Cable	Candox	5B-048-98-98-5000	111130	Mar. 09, 16	Mar. 31, 17
W13	Coaxial Cable	Suhner	SUCOFLEX106	KSR00207	May. 23, 16	May. 31, 17

Measuring Equipment Configuration

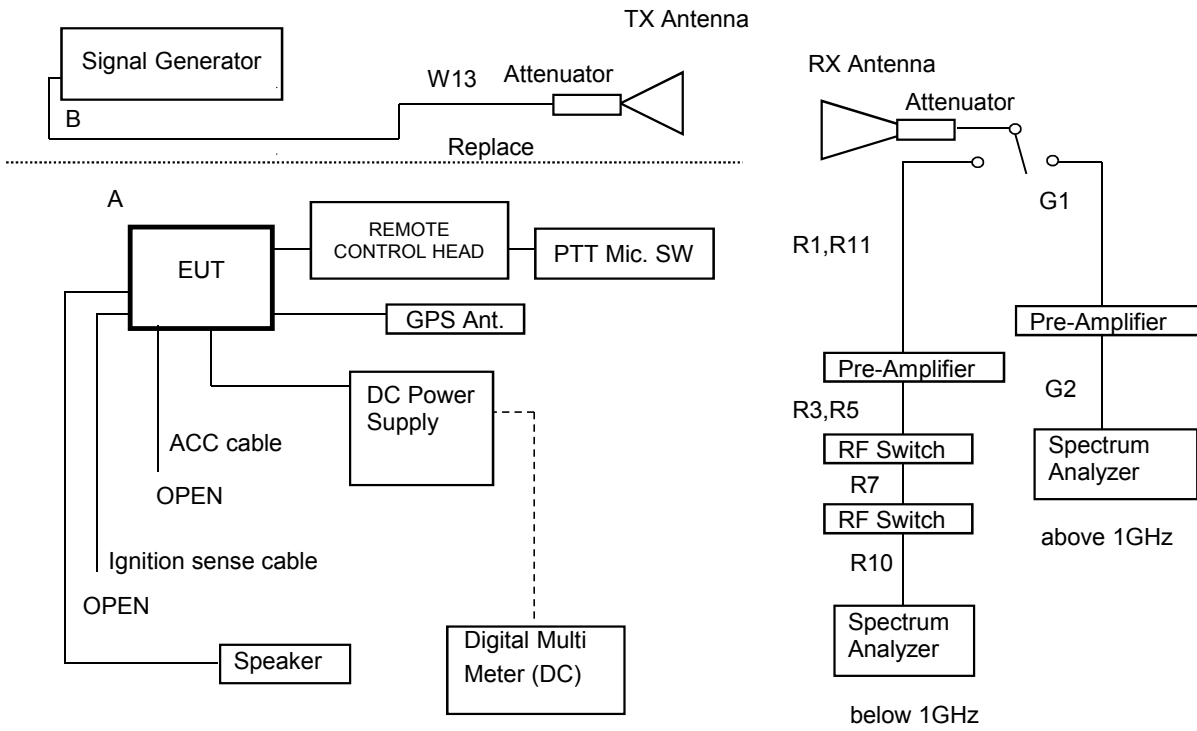

Test Results

Test date	Jun 28, 2016 to Jul 7, 2016
Location	Kashima No.12 Test Site
temperature	20.5 to 28.1 [degree C]
Humidity Variation	45 to 71 [%]
Atmospheric Pressure	98.5 to 99.5 [kPa]
Test Engineer	Koichi Wagatsuma

Test was carried out for all the frequency band of section 10.1
 State the worst case(below)

State: High Power / Authorized Bandwidth 11.25 kHz / 774.95MHz (Band 1)

No.	Spurious Frequency (MHz)	Pol.	Reading Level (dBm)	SG Out Level (dBm)	Ant. Gain (dBd)	Loss (dB)	Correct Level (dBm)	Emission Level (dBc)	Limit Level (dBc)	Margin (dB)
1	1549.90	Hor.	-53.41	-40.43	6.10	13.09	-47.4	-92.2	-57.8	34.4
		Ver.	-53.01	-38.04	6.10	13.09	-45.0	-89.8	-57.8	32.0
2	2324.85	Hor.	-	-	7.25	13.88	-	-	-57.8	-
		Ver.	-	-	7.25	13.88	-	-	-57.8	-
3	3099.80	Hor.	-60.42	-41.16	7.59	14.54	-48.1	-92.9	-57.8	35.1
		Ver.	-61.22	-40.69	7.59	14.54	-47.6	-92.4	-57.8	34.6
4	3874.75	Hor.	-	-	7.71	15.08	-	-	-57.8	-
		Ver.	-	-	7.71	15.08	-	-	-57.8	-
5	4649.70	Hor.	-	-	8.83	15.58	-	-	-57.8	-
		Ver.	-	-	8.83	15.58	-	-	-57.8	-
6	5424.65	Hor.	-	-	8.67	16.07	-	-	-57.8	-
		Ver.	-	-	8.67	16.07	-	-	-57.8	-
7	6199.60	Hor.	-	-	9.22	16.55	-	-	-57.8	-
		Ver.	-	-	9.22	16.55	-	-	-57.8	-
8	6974.55	Hor.	-	-	9.61	17.04	-	-	-57.8	-
		Ver.	-	-	9.61	17.04	-	-	-57.8	-
9	7749.50	Hor.	-	-	9.50	17.49	-	-	-57.8	-
		Ver.	-	-	9.50	17.49	-	-	-57.8	-

There is the margin of 20dB over except for the above points.

§ 90.543 (c) Limit (dBc) = -(43+10Log(P))

Correct Level (dBm) = Substitute SG Level (dBm) + ANT Gain (dBi) - Loss (Cable, Attenuator) (dB)

Emission Level (dBc) = Correct Level (dBm) - 10Log(P*1000)

P = Carrier Level (W)

" - " = Measurement Limit

State: Low Power / Authorized Bandwidth 11.25 kHz / 774.95MHz (Band 1)

No.	Spurious Frequency (MHz)	Pol.	Reading Level (dBm)	SG Out Level (dBm)	Ant. Gain (dBd)	Loss (dB)	Correct Level (dBm)	Emission Level (dBc)	Limit Level (dBc)	Margin (dB)
1	1549.90	Hor.	-59.15	-46.17	6.10	13.09	-53.2	-86.2	-46.0	40.2
		Ver.	-60.53	-45.56	6.10	13.09	-52.6	-85.6	-46.0	39.6
2	2324.85	Hor.	-	-	7.25	13.88	-	-	-46.0	-
		Ver.	-	-	7.25	13.88	-	-	-46.0	-
3	3099.80	Hor.	-	-	7.59	14.54	-	-	-46.0	-
		Ver.	-	-	7.59	14.54	-	-	-46.0	-
4	3874.75	Hor.	-	-	7.71	15.08	-	-	-46.0	-
		Ver.	-	-	7.71	15.08	-	-	-46.0	-
5	4649.70	Hor.	-	-	8.83	15.58	-	-	-46.0	-
		Ver.	-	-	8.83	15.58	-	-	-46.0	-
6	5424.65	Hor.	-	-	8.67	16.07	-	-	-46.0	-
		Ver.	-	-	8.67	16.07	-	-	-46.0	-
7	6199.60	Hor.	-	-	9.22	16.55	-	-	-46.0	-
		Ver.	-	-	9.22	16.55	-	-	-46.0	-
8	6974.55	Hor.	-	-	9.61	17.04	-	-	-46.0	-
		Ver.	-	-	9.61	17.04	-	-	-46.0	-
9	7749.50	Hor.	-	-	9.50	17.49	-	-	-46.0	-
		Ver.	-	-	9.50	17.49	-	-	-46.0	-

There is the margin of 20dB over except for the above points.

§ 90.543 (c) Limit (dBc) = -(43+10Log(P))

Correct Level (dBm) = Substitute SG Level (dBm) + ANT Gain (dBi) - Loss (Cable, Attenuator) (dB)

Emission Level (dBc) = Correct Level (dBm) - 10Log(P*1000)

P = Carrier Level (W)

" - " = Measurement Limit

State: High Power / Authorized Bandwidth 11.25 kHz / 799.05MHz (Band 2)

No.	Spurious Frequency (MHz)	Pol.	Reading Level (dBm)	SG Out Level (dBm)	Ant. Gain (dBd)	Loss (dB)	Correct Level (dBm)	Emission Level (dBc)	Limit Level (dBc)	Margin (dB)
1	1598.10	Hor.	-50.52	-37.32	6.17	13.15	-44.3	-89.1	-57.8	31.3
		Ver.	-53.98	-38.77	6.17	13.15	-45.7	-90.5	-57.8	32.7
2	2397.15	Hor.	-61.65	-44.74	7.40	13.94	-51.3	-96.0	-57.8	38.3
		Ver.	-61.12	-42.20	7.40	13.94	-48.7	-93.5	-57.8	35.7
3	3196.20	Hor.	-	-	7.67	14.61	-	-	-57.8	-
		Ver.	-	-	7.67	14.61	-	-	-57.8	-
4	3995.25	Hor.	-	-	7.64	15.16	-	-	-57.8	-
		Ver.	-	-	7.64	15.16	-	-	-57.8	-
5	4794.30	Hor.	-	-	8.81	15.68	-	-	-57.8	-
		Ver.	-	-	8.81	15.68	-	-	-57.8	-
6	5593.35	Hor.	-	-	8.76	16.17	-	-	-57.8	-
		Ver.	-	-	8.76	16.17	-	-	-57.8	-
7	6392.40	Hor.	-	-	9.67	16.67	-	-	-57.8	-
		Ver.	-	-	9.67	16.67	-	-	-57.8	-
8	7191.45	Hor.	-	-	9.37	17.17	-	-	-57.8	-
		Ver.	-	-	9.37	17.17	-	-	-57.8	-
9	7990.50	Hor.	-	-	9.25	17.64	-	-	-57.8	-
		Ver.	-	-	9.25	17.64	-	-	-57.8	-

There is the margin of 20dB over except for the above points.

§ 90.543 (c) Limit (dBc) = -(43+10Log(P))

Correct Level (dBm) = Substitute SG Level (dBm) + ANT Gain (dBi) - Loss (Cable, Attenuator) (dB)

Emission Level (dBc) = Correct Level (dBm) - 10Log(P*1000)

P = Carrier Level (W)

" - " = Measurement Limit

State: Low Power / Authorized Bandwidth 11.25 kHz / 799.05MHz (Band 2)

No.	Spurious Frequency (MHz)	Pol.	Reading Level (dBm)	SG Out Level (dBm)	Ant. Gain (dBd)	Loss (dB)	Correct Level (dBm)	Emission Level (dBc)	Limit Level (dBc)	Margin (dB)
1	1598.10	Hor.	-57.26	-44.06	6.17	13.15	-51.0	-84.0	-46.0	38.0
		Ver.	-61.11	-45.90	6.17	13.15	-52.9	-85.9	-46.0	39.9
2	2397.15	Hor.	-	-	7.40	13.94	-	-	-46.0	-
		Ver.	-	-	7.40	13.94	-	-	-46.0	-
3	3196.20	Hor.	-	-	7.67	14.61	-	-	-46.0	-
		Ver.	-	-	7.67	14.61	-	-	-46.0	-
4	3995.25	Hor.	-	-	7.64	15.16	-	-	-46.0	-
		Ver.	-	-	7.64	15.16	-	-	-46.0	-
5	4794.30	Hor.	-	-	8.81	15.68	-	-	-46.0	-
		Ver.	-	-	8.81	15.68	-	-	-46.0	-
6	5593.35	Hor.	-	-	8.76	16.17	-	-	-46.0	-
		Ver.	-	-	8.76	16.17	-	-	-46.0	-
7	6392.40	Hor.	-	-	9.67	16.67	-	-	-46.0	-
		Ver.	-	-	9.67	16.67	-	-	-46.0	-
8	7191.45	Hor.	-	-	9.37	17.17	-	-	-46.0	-
		Ver.	-	-	9.37	17.17	-	-	-46.0	-
9	7990.50	Hor.	-	-	9.25	17.64	-	-	-46.0	-
		Ver.	-	-	9.25	17.64	-	-	-46.0	-

There is the margin of 20dB over except for the above points.

§ 90.543 (c) Limit (dBc) = -(43+10Log(P))

Correct Level (dBm) = Substitute SG Level (dBm) + ANT Gain (dBi) - Loss (Cable, Attenuator) (dB)

Emission Level (dBc) = Correct Level (dBm) - 10Log(P*1000)

P = Carrier Level (W)

" - " = Measurement Limit

7.6 Necessary Bandwidth and Emission Bandwidth

REGULATIONS	: FCC Part 2 Section 202 (g) & Federal Register/ Vol.68, No236 TRC 43
-------------	--------------------------------------------------------------------------

Calculation Results

State : 7K60FXE / 7K60FXD (9600bps, Authorized Bandwidth 11.25 kHz)

Item	Mark		
Digital information rate	(R)	9600	bps
Peak frequency deviation	(D)	3.024	kHz
Signaling states	(S)	4	
Numerical factor	(K)	0.463	
Necessary Bandwidth	(Bn)	7.6	kHz

$B_n = (R/\log_2 S) + 2xDxK$

types of modulation of the main carrier :
 nature of signal(s) modulating the main carrier:
 type of information to be transmitted:

- F = Frequency modulation
- X = Cases not otherwise covered
- E = Telephony (including sound broadcasting)
- D = Data transmission, telemetry, telecommand

7.7 99% Occupied Bandwidth

REGULATIONS	: RSS-119 Section 5.5
TEST METHOD/GUIDE	: RSS-Gen Section 6.6

Test Procedure

- 1 The EUT and test equipment were set up as shown on the following page
- 2 Adjust the test instrument for the following setting:
 - RBW : 1 % to 5 % of the Necessary bandwidth
 - VBW : at least 3 times the RBW
 - Detector : Peak
 - Sweep Time : Auto
 - Trace mode : Max Hold
- 3 Allow trace to fully stabilize.
- 4 Use "Occupied Bandwidth Measurement" function to measure the 99% Occupied Bandwidth
- 5 Modulate the transmitter with a 2.5 kHz sine wave at an input Level of 16 dB greater than that necessary to produce 50 % of rated system deviation.(Only 16K0F3E, 11K0F3E;

Measuring Equipments

No.	Equipment	Manufacture	Model No.	Serial No.	Cal Date	Cal Exp.
1	Attenuator (20dB)	Aeroflex/Wenshel	66-20-34	BY4357	May. 23, 2016	May. 31, 2017
2	Attenuator (30dB)	Weinschel	WA-29-30-34	8923	May. 23, 2016	May. 31, 2017
3	Spectrum Analyzer	Agilent	N9030A	US51350220	Dec. 02, 2015	Dec. 31, 2016
4	DC Power Supply	Daiichi denpa kogyo	GZV4000	90290931	None	None
5	Digital Multi Meter	FLUKE	8846A	9642018	Jul. 10, 2015	Jul. 31, 2016
6	Coaxial Cable	Suhner	SUCOFLEX104	F0000017	Jan. 15, 2016	Jan. 31, 2017

Measuring Equipment Configuration

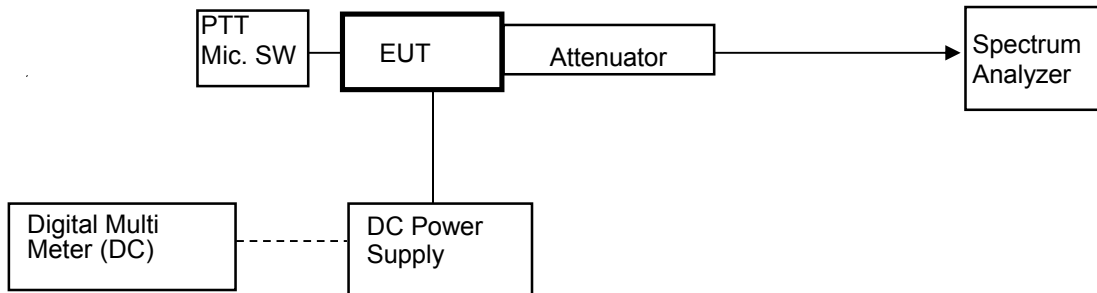

Test Results

Test date	Jul 14, 2016
Location	Kashima No.1 Test Site
temperature	20 [degree C]
Humidity Variation	60 [%]
Atmospheric Pressure	101.6 [kPa]
Test Engineer	Koichi Wagatsuma

Emission Designation	Frequency (MHz)	99% Occupied Bandwidth (kHz)	Authorized bandwidth (kHz)
7K60FXD/FXE	769.05	7.500	11.25
	774.95	7.505	
	799.05	7.509	
	804.95	7.506	
	806.05	7.434	
	815.05	7.437	
	823.95	7.428	
	851.05	7.439	
	860.05	7.443	
	868.95	7.401	

