



TEST REPORT

REGULATION : FCC Part 2, 90
RSS-119 Issue 11

Applicant	Testing Laboratory
JVC KENWOOD Corporation 1-16-2, Hakusan, Midori-ku, Yokohama-shi Kanagawa, 226-8525 Japan Tel.: +81 45 939 6254 Fax.: +81 45 939 6261	Intertek Japan K. K. Kashima Laboratory 3-2, Sunayama, Kamisu-shi, Ibaraki-ken 314-0255 Japan Tel.: +81 479 40 1097

Equipment type	800MHz DIGITAL TRANSCEIVER
Trademark	KENWOOD
FCC Model(s)	NX-920G-K, NX-920-K
IC Model	NX-920G-K
Serial No.	00012042
FCC ID	K44458300
IC CN and UPN	282F-458300
Test Result	Complied
Report Number	13040117JKA-005
Report issue date	May 29, 2013
Revised issue date	June 10, 2013

This report is for the exclusive use of Intertek's Client and is provided pursuant to the agreement between Intertek and its Client. Intertek's responsibility and liability are limited to the terms and conditions of the agreement. Intertek assumes no liability to any party, other than to the Client in accordance with the agreement, for any loss, expense or damage occasioned by the use of this report. Only the Client is authorized to permit copying or distribution of this report and then only in its entirety. Any use of the Intertek name or one of its marks for the sale or advertisement of the tested material, product or service must first be approved in writing by Intertek. The observations and test results in this report are relevant only to the sample tested. This report by itself does not imply that the material, product, or service is or has ever been under an Intertek certification program.

Approved by

Kazuo Gokita

[Manager]

Tested by

Koichi Wagatsuma

In Accordance with FCC Rules and Regulations, Volume II, Part 2 and 90

Sub-part 2.1033

(c)(1) Applicant and Manufacture Information	
APPLICANT	
Company	: JVC KENWOOD Corporation
Address	: 1-16-2, Hakusan, Midori-ku, Yokohama-shi Kanagawa, 226-8525 Japan
Contact Person	: Tamaki Shimamura Manager, Communications Equipment Division
MANUFACTURER	
Company	: JVC KENWOOD Corporation
Address	: 1-16-2, Hakusan, Midori-ku, Yokohama-shi Kanagawa, 226-8525 Japan
(c)(2) FCC ID	
FCC ID	: K44458300
Model number	: NX-920G-K, NX-920-K
Serial number	: 00012042
(c)(3) Instruction Manual(S)	
Instruction manual(s)	: Please refer to attached Exhibits F
(c)(4) Type of Emission	
Emission Designation	: 16K0F3E(Wide) / 14K0F3E(Wide) / 11K0F3E(Narrow) 8K30F1E(Narrow) / 8K30F1D(Narrow) / 8K30F7W(Narrow) 4K00F1E(Very Narrow) / 4K00F1D(Very Narrow) / 4K00F7W(Very Narrow) 4K00F2D(Very Narrow)
(c)(5) Frequency range	
Frequency Range	: 806 to 824 MHz and 851 to 869 MHz(FCC/RSS)
(c)(6) Power Rating	
Output Power	: 5 to 15 W
Type	: Continuously Variable
(c)(7) Maximum Power Rating	
Output Power	: 15 W
(c)(8): Voltages & currents in all elements in final RF stage, including final transistor or solid-state device	
Collector Current, A	: 9.0 amps (Maximum)
Collector Voltage, Vdc	: 13.6 Vdc
Supply Voltage, Vdc	: 13.6 Vdc
Other Information	
Number of Channel	: Zone 128 max, Cannel 260 max.
Maximum Deviation	: ± 5.0 kHz , ± 4.0 kHz , ± 2.5 kHz
Frequency Stability	: 1.0 ppm
:	:
Antenna Impedance	: 50 Ω Nominal
Note	

TABLE OF CONTENTS

	Page
SECTION 1. GENERAL INFORMATION	4
SECTION 2. SUMMARY OF TEST RESULT	5
SECTION 3. TEST AND MEASUREMENT DATA	6
SECTION 4. INFORMATION ABOUT EUT AND SUPPORT EQUIPMENT(S)	7
SECTION 5. SUPPORT EQUIPMENT	8
SECTION 6. USED CABLE(S)	9
SECTION 7. TEST CONFIGURATION	10
SECTION 8. OPERATING CONDITION	11
SECTION 9. MEASUREMENT UNCERTAINTY	12
SECTION 10. TEST DATA	
10.1 Carrier Output Power (Conducted)	13
10.2 Unwanted Emissions (Transmitter Conducted)	15
10.3 Field Strength of Spurious Radiation	18
10.4 Emission Masks (Occupied Bandwidth)	24
10.5 Transient Frequency Behavior	46
10.6 Audio Frequency Response / Audio Low Pass Filter (Voice Input)	60
10.7 Modulation Limiting	65
10.8 Frequency Stability (Temperature Variation)	73
10.9 Frequency Stability (Voltage Variation)	77
10.10 Receiver Spurious Emissions(Radiated)	79
10.11 Necessary Bandwidth and Emission Bandwidth	83
APPENDIX PHOTOGRAPHS	

SECTION 1. GENERAL INFORMATION**TEST PERFORMED**

Location	Kashima No.1 Test Site and No.12 Test Site		
EUT Received	April 23, 2013		
Date of Test	April 24, 2013	to	May 22, 2013
Standard Applied	FCC Part 2, 90 RSS-119 Issue 11		
Measurement Method	ANSI/TIA-603-D-2010 / RSS-119 Issue 11(2011), RSS-Gen Issue 3(2010)		
Deviation from Standard(s)	Not applicable		

QUALIFICATIONS OF TESTING LABORATORY (Kashima Lab.)

ACCREDITATION	SCOPE	LAB. CODE	Remarks
NVLAP	EMC Testing	100290-0	USA
VLAC	EMC Testing	VLAC-008-1	JAPAN
BSMI	EMC Testing	SL2-IN-E-6008	TAIWAN
FILING			
VCCI	EMC Testing	A-0126	JAPAN
FCC	EMC Testing	Designation Number:JP0008	
IC	EMC Testing	IC-2042K-1, IC-2042K-3, , IC-2042Q-12	CANADA
CB-Scheme	EMC Testing	TL222	IECEE
SAUDI ARABIA	EMC Testing	N/A	

ABBREVIATIONS

EUT	Equipment Under Test	DoC	Declaration of Conformity
AMN	Artificial Mains Network	ISN	Impedance Stabilization Network
LISN	Line Impedance Stabilization Network	Q-P	Quasi-peak
AMP	Amplifier	AVG	Average
ATT	Attenuator	PK	Peak
ANT	Antenna	Cal	Calibration
BBA	Broadband Antenna	N/A	Not applicable or Not available
DIP	Dipole Antenna	LCD	Liquid-Crystal Display
AE	Associated Equipment	4LEVEL FSK	4LEVEL Frequency Shift Key
GMSK	Gaussian Maximum Shift Key	CW ID	Continuously Repeating bit stream
FM	Frequency Modulation	C4FM	Constant envelope 4 Level FM
PTT	Push to Talk	AFC	Automatic frequency control

Revision Summary

Revised Date	Section	Description of Changes
June 10, 2013	Cover page	<ul style="list-style-type: none"> • Addition of IC Model • Change of the original report number 13040117JKA-003 to 13040117JKA-005

SECTION 2. SUMMARY OF TEST RESULT

FCC Part2	Part90	IC RSS-119	TEST ITEM	RESULTS
2.1046 (a)	-	5.4	Carrier Output Power (Conducted)	PASS
2.1051	90.210	5.8	Unwanted Emissions (Transmitter Conducted)	PASS
2.1053 (a)	90.210	5.8	Field Strength of Spurious Radiation	PASS
2.1049 (c) (1)	90.210	5.8	Emission Masks (Occupied Bandwidth)	PASS
-	90.214	5.9	Transient Frequency Behavior	PASS
2.1047 (a)	90.210	-	Audio Low Pass Filter (Voice Input)	PASS
2.1047 (a)	-	-	Audio Frequency Response	PASS
2.1047 (b)	-	-	Modulation Limiting	PASS
2.1055 (a) (1)	90.213 (a)	5.3	Frequency Stability (Temperature Variation)	PASS
2.1055 (d) (1)	90.213 (a)	5.3	Frequency Stability (Voltage Variation)	PASS
-	-	5.11	Receiver Spurious Emissions	PASS
-	90.203 (i)	-	Certification required (FCC Part 90.203(i))	Complied
-	90.203 (e)	-	Certification required (FCC Part 90.203(e))	Complied

Limitation on Results

The test result of this report is effective equipment under test itself and under the test configuration described on the report.

This test report does not assure that whether the test result taken in other testing laboratory is compatible or reproducible to the test result on this report or not.

Note:

As for the FCC Part 15 Subpart B-Unintentional Radiators, the EUT has been measured and declared as Verification by JVC Kenwood Corporation.

SECTION 3. TEST AND MEASUREMENT DATA

All test and measurements indicated in this document were performed in accordance with the Code of Federal Regulations Title 47 Part 2, Sub-part J and Industry Canada as the following individual parts:

FCC Rule	Test Item	Tested
Part 21	Domestic Public Fixed radio Services	N.A.
Part 22	Non Cellular	N.A.
Part 22	Public Mobile Services	N.A.
Part 22	Subpart H - Cellular Radiotelephone Service	N.A.
Part 22	Alternative technologies and auxiliary service	N.A.
Part 23	International Fixed Public Radiocommunication service	N.A.
Part 24	Personal Communications Services	N.A.
Part 74	Experimental Radio Auxiliary , Special Broadcast and Other Program Distributional Services	N.A.
Part 80	Stations in the Maritime Services	N.A.
Part 80	Subpart E - general Technical Standards	N.A.
Part 80	Subpart F - Equipment Authorization for Compulsory Ships	N.A.
Part 80	Subpart K - Private Coast Stations and Marine Utility Stations	N.A.
Part 80	Subpart S - Compulsory radiotelephone Installations for Small Passenger Boats	N.A.
Part 80	Subpart T - Radiotelephone Installation Required for Vessels on the Great Lakes	N.A.
Part 80	Subpart U - Radiotelephone Installations Required by the Bridge-to- Bridge Act	N.A.
Part 80	Subpart V - Emergency Position Indicating Radiobeacons (EPIRB'S)	N.A.
Part 80	Subpart W - Global Maritime Distress and Safety System (GMDSS)	N.A.
Part 80	Subpart X - Voluntary Radio Installations	N.A.
Part 87	Aviation Services	N.A.
Part 90	Private Land Mobile radio Services	YES
Part 94	Private Operational - Fixed Microwave Service	N.A.
Part 95	Subpart A - General Mobile radio Service	N.A.
Part 95	Subpart C - Radio Control (R/C) radio Service	N.A.
Part 95	Subpart D - Citizens Band (CB) Radio Service	N.A.
Part 95	Subpart E -Family radio Service	N.A.
Part 95	Subpart F -Interactive Video and Data Service (IVDS)	N.A.
Part 97	Amateur Radio Service	N.A.
Part 101	Fixed Microwave Service	N.A.

IC Rule	Test Item	Tested
RSS-119	Radio Transmitters and Receivers Operating in the Land Mobile and Fixed Services in the Frequency Range 27.4-960 MHz	YES
RSS-134	900MHz Narrowband Personal Communication Service	N.A.
RSS-Gen	General Requirements and Information for the Certification of Radio Apparatus	YES

SECTION 4. INFORMATION ABOUT EUT AND SUPPORT EQUIPMENT(S)

4.1 List of System Configuration

Symbol	Item	Model No.	Serial No.	Manufacture	Remarks
A	800MHz DIGITAL TRANSCEIVER	NX-920G-K, NX-920-K	00012042	JVC KENWOOD Corporation	EUT
Power Ratings of EUT :		DC 13.6 V +/- 15%		9.0 A Maximum	
Power Supply :		DC 13.6 V +/- 15%			
Condition of Equipment		Proto type			
Type		Mobile type			
Suppression Devices		No Modifications by the laboratory were made to the device			

4.2 Port(s)/Connector(s)

Port Name	Connector Type	Connector Pin	Remarks
ACC	D-sub	15 pin	
External Speaker	3.5φ	2 pin	
Antenna	N	2 pin	
Microphone	RJ-45	8 pin	
GPS Antenna	SMA	2 pin	

4.3 Highest Frequency Oscillator(s)/Crystal(s)

Base Clock	Operating Frequency	Board Name	Remarks
869.00 MHz	869.00 MHz	TX UNIT	
870.00 MHz	870.00 MHz	RX UNIT	
3144.84 MHz	3144.84 MHz	GPS Unit	

4.4 Variation of Model(s)

Model No.	Description	Remarks
NX-920G-K	With GPS UNIT	Tested model
NX-920-K	Without GPS UNIT	

4.5 Receiver Frequency Range

Fequency	Remarks
851 to 870 MHz	

SECTION 5. SUPPORT EQUIPMENT

The EUT was supported by the following equipment during the test.

Symbol	Item	Model No.	Serial No.	Manufacture	FCC ID
B	DC Power Supply (1)	PMC35-3A	LE000716	KIKUSUI	N/A
C	External Speaker	KES-3	None	JVC KENWOOD	N/A
D	Keypad Microphone	KMC-32	None	JVC KENWOOD	N/A
E	Dummy Load	CT-150NP	None	TME	N/A
F	GPS ACTIVE ANTENNA	KRA-40	None	JVC KENWOOD	N/A
G	DC Power Supply (2)	GZV4000	90290931	Daiichi Denpa Kogyo	N/A
H	DC Power Supply (3)	GP035-20R	1014199060	TAKASAGO	N/A

Supplied Power:

B,G,H	AC	100V,60Hz
-------	----	-----------

SECTION 6. USED CABLE(S)

The following cable(s) was used for the test.

No.	Name	Length (m)	Shield	Connector	Ferrite core
1	Speaker cable	2.90	No	Plastic	
2	Coaxial cable	1.00	Yes	Metal	
3	Mic. Cable	0.55	No	Plastic	
4	KCT-18 (Ignition sense cable)	0.25	Yes	Plastic	
5	KCT-60 (Connection cable)	0.30	No	Plastic	
6	DC cable	0.25	No	Plastic	
7	DC cable	3.15	No	Plastic	
8	GPS Antenna cable	5.00	Yes	Metal	
9	Power cable for DC Power Supply (1)	2.00	No	-	
10	Power cable for DC Power Supply (2)	1.80	No	-	
11	Power cable for DC Power Supply (3)	1.80	No	-	

SECTION 7. TEST CONFIGURATION

Details of Configuration and Connection

Example: Case of Section 10.3Test

- * : EUT
- : Ferrite core
- : Joint Connector

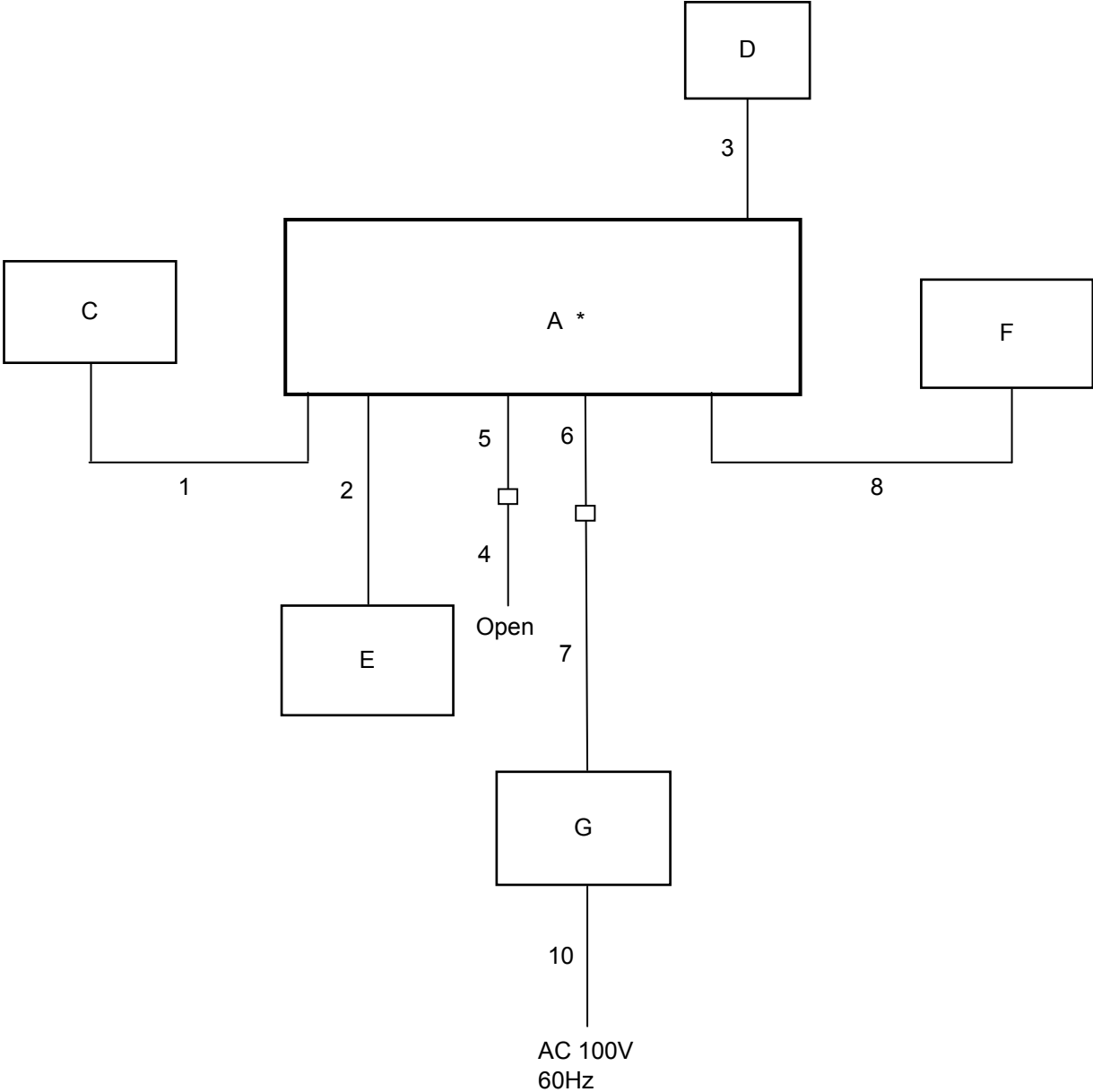

SECTION 8. OPERATING CONDITION

The EUT was operated under the following condition during the test.

8.1 Operating Condition

The test was carried out under Transmit mode.

(FCC/RSS: 806.05MHz, 815.05MHz, 823.95MHz 851.05MHz, 860.05MHz, 868.95MHz)

(High Power : 15W, Low Power : 5 W)

The test was carried out under Receive mode.

(RSS: 851.05MHz, 860.05MHz, 868.95MHz)

EUT was examined in the operating conditions that had maximum emissions.

8.2 Operating Flow [Transmit mode]

Following operations were performed continuously.

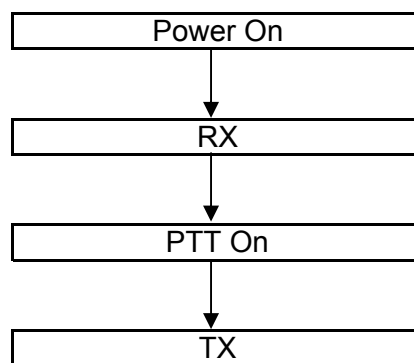

8.3 Operating Flow [Receive mode]

Following operations were performed continuously.

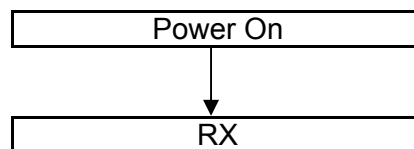

SECTION 9. MEASUREMENT UNCERTAINTY

Carrier Output Power (Conducted)	U_{lab}	$U_{tia-603-d}$
	+/- 0.29dB ($k = 2$)	+/- 0.59 dB
Unwanted Emissions (Transmitter Conducted)		
	+/- 2.19 dB ($k = 2$)	+/- 1.1 dB
Field Strength of Spurious Radiation		
	+/- 4.96dB ($k = 2$)	+/- 3.3 dB
Emission Masks (Occupied Bandwidth)		
	+/- 0.5dB ($k = 2$)	+/- 2.1 dB
Transient Frequency Behavior		
	+/- 1.10% ($k = 2$)	+/- 21.6 %
Audio Low Pass Filter (Voice Input)		
	+/- 0.1dB ($k = 2$)	+/- 1.2 dB
Audio Frequency Response		
	+/- 0.1dB ($k = 2$)	+/- 1.2 dB
Modulation Limiting		
	+/- 1% ($k = 2$)	+/- 1 %
Frequency Stability (Temperature Variation)		
	+/- 10.1Hz ($k=2$)	+/-34.2 Hz
Frequency Stability (Voltage Variation)		
	+/- 10.1Hz ($k=2$)	+/-34.2 Hz
Receiver Spurious Emissions	U_{lab}	U_{cispr}
30-1000MHz	+/- 4.48dB ($k = 2$)	+/- 5.2 dB
above 1GHz	+/- 4.84dB ($k = 2$)	

SECTION 10. TEST DATA

10.1 Carrier Output Power (Conducted)

REGULATIONS	: FCC Part 2 Section 1046 (a) / RSS-119 Section 5.4
TEST METHOD/GUIDE	: ANSI/TIA-603-D Section 2.2.1.2 / RSS-119 Section 4.1

Test Procedure

- 1 The EUT and test equipment were set up as shown on the following page.
- 2 The EUT was conducted to a resistive coaxial attenuator of nominal load impedance.
 $RF\ Power\ (dBm) = Power\ Meter\ reading\ (dBm) + Attenuator\ Loss\ (dB) + Cable\ Loss\ (dB)$
 $RF\ Power\ (W) = 10^{(RF\ Power\ (dBm)/10)}/1000$
- 3 Modulate the transmitter with a 2.5 kHz sine wave at an input Level of 16 dB greater than that necessary to produce 50 % of rated system deviation.(Only as for the test of RSS)

Measuring Equipments

No.	Equipment	Manufacture	Model No.	Serial No.	Cal Date	Cal Exp.
1	Power Meter	Hewlett Packard	E4418B	GB38410265	May 10, 12	May 31, 13
2	Power Sensor	Hewlett Packard	8482A	US37292237	May 10, 12	May 31, 13
3	Attenuator (20dB)	Aeroflex/Wenschel	66-20-34	BY4357	May 09, 12	May 31, 13
4	Attenuator (30dB)	Weinschel	WA-29-30-34	8923	May 09, 12	May 31, 13
5	Audio Generator	Anritsu	MG443B	M70150	Apr. 05, 13	Apr. 30, 14
5	Modulation Analyzer	Hewlett Packard	8901B	3403A04852	Aug 09, 12	Aug 31, 13
6	Digital Multi Meter	FLUKE	8846A	9642018	May 11, 12	May 31, 13
7	DC Power Supply	Daiichi denpa kogyo	GZV4000	90290931	None	None

Measuring Cables

No.	Cable	Manufacturer	Model No.	Serial No.	Cal Date	Cal Exp.
W1	Coaxial Cable	Suhner	SUCOFLEX104	KSR00211	Dec 20, 12	Dec 31, 13
W6	Balance Cable	Nicoon	3D-2V	KSR00092	Dec. 21, 12	Dec. 31, 13
W10	Coaxial Cable	Pacific custom	RG-58 C/U	KSR00097	Dec. 21, 12	Dec. 31, 13

Measuring Equipment Configuration

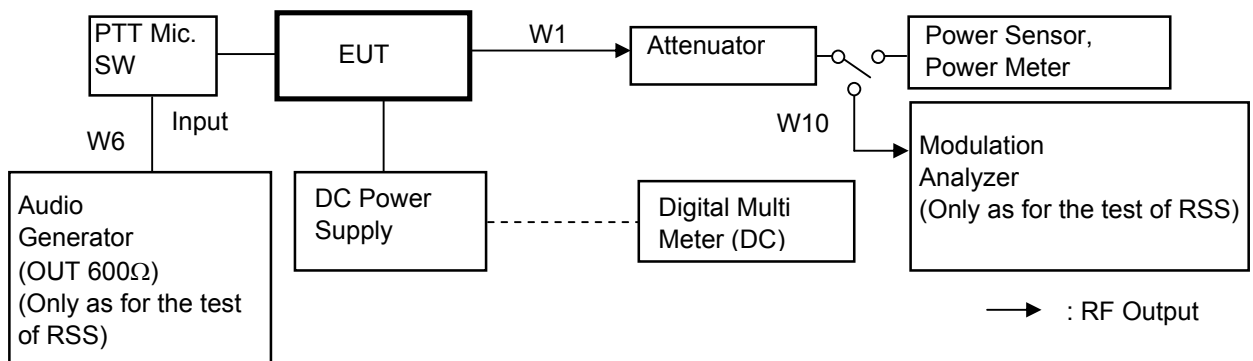

Test Results

Test date	Apr. 24, 2013	
Location	Kashima No.1 Test Site	
temperature	21.2	[degree C]
Humidity Variation	55.0	[%]
Atmospheric Pressure	101.4	[kPa]
Test Engineer	Koichi Wagatsuma	

Test was carried out for all the Authorized Bandwidth.
 State the worst case (below).

No.	Frequency (MHz)	Band		Setting	RF Power (W)
1	806.05		Low (FCC/RSS)	High Power	15
2	815.05	Band 1	Middle (FCC/RSS)	High Power	15
3	823.95		High (FCC/RSS)	High Power	15
4	851.05		Low (FCC/RSS)	High Power	15
5	860.05	Band2	Middle (FCC/RSS)	High Power	15
6	868.95		High (FCC/RSS)	High Power	15
7	806.05		Low (FCC/RSS)	Low Power	5
8	815.05	Band 1	Middle (FCC/RSS)	Low Power	5
9	823.95		High (FCC/RSS)	Low Power	5
10	851.05		Low (FCC/RSS)	Low Power	5
11	860.05	Band2	Middle (FCC/RSS)	Low Power	5
12	868.95		High (FCC/RSS)	Low Power	5

RF Power: Peak reading

10.2 Unwanted Emissions (Transmitter Conducted)

REGULATIONS	: FCC Part 2 Section 1051, Part 90 Section 210 / RSS-119 Section 5.8
TEST METHOD/GUIDE	: ANSI/TIA-603-D Section 2.2.13.2 / RSS-119 Section 4.2, RSS-Gen Section 4.9

Test Procedure

- 1 The EUT and test equipment were set up as shown on the following page.
- 2 Modulate the transmitter with a 2.5 kHz sine wave at an input Level of 16 dB greater than that than that necessary to produce 50 % of rated system deviation.
- 3 Adjust the spectrum analyzer for the following setting:
 - a) RBW : 10 kHz (< 1 GHz), 1 MHz (> 1 GHz).
 - b) VBW : 30 kHz (< 1 GHz), 3 MHz (> 1 GHz).
 - c) Sweep Speed : 50 msec.
 - d) Detector mode : Average power (FM Modulation) , Positive peak with peak hold (Digital Modulation)
- 4 The emissions were measured for the worst case as follows:
 - a) : within a band of frequencies defined by the carrier frequency plus and minus one channel.
 - b) : from the lowest frequency generated in the EUT and to at least the 10th harmonic of the carrier frequency, or 40 GHz, whichever is lower.

Measuring Equipments

No.	Equipment	Manufacture	Model No.	Serial No.	Cal Date	Cal Exp.
1	Attenuator (10dB)	Aeroflex/Wenshel	66-10-34	BY2887	May 09, 12	May 31, 13
2	Attenuator (30dB)	Weinschel	WA-29-30-34	8923	May 09, 12	May 31, 13
3	Highpass Filter	TME	UHP-127	1511798E	May 09, 12	May 31, 13
4	Audio Generator	Anritsu	MG443B	M70150	Apr. 05, 13	Apr. 30, 14
5	Modulation Analyzer	Hewlett Packard	8901B	3403A04852	Aug. 09, 12	Aug. 31, 13
6	Signal Generator	Rohde&Schwarz	SMP02	845275/007	Jan. 24, 13	Jan. 31, 14
7	Spectrum Analyzer	Agilent	E4407B	MY45102460	Apr. 06, 13	Apr. 30, 14
8	Digital Multi Meter	FLUKE	8846A	9642018	May 11, 12	May 31, 13
9	DC Power Supply	Daiichi denpa kogyo	GZV4000	90290931	None	None

Measuring Cables

No.	Cable	Manufacture	Model No.	Serial No.	Cal Date	Cal Exp.
W1	Coaxial Cable	Suhner	SUCOFLEX104	KSR00211	Dec. 20, 12	Dec. 31, 13
W2	Coaxial Cable	Suhner	SUCOFLEX104	F0000017	Dec. 20, 12	Dec. 31, 13
W4	Coaxial Cable	Pacific custom	RG-58 C/U	KSR00097	Dec. 21, 12	Dec. 31, 13
W6	Balance Cable	Nicoon	3D-2V	KSR00092	Dec. 21, 12	Dec. 31, 13

Measuring Equipment Configuration

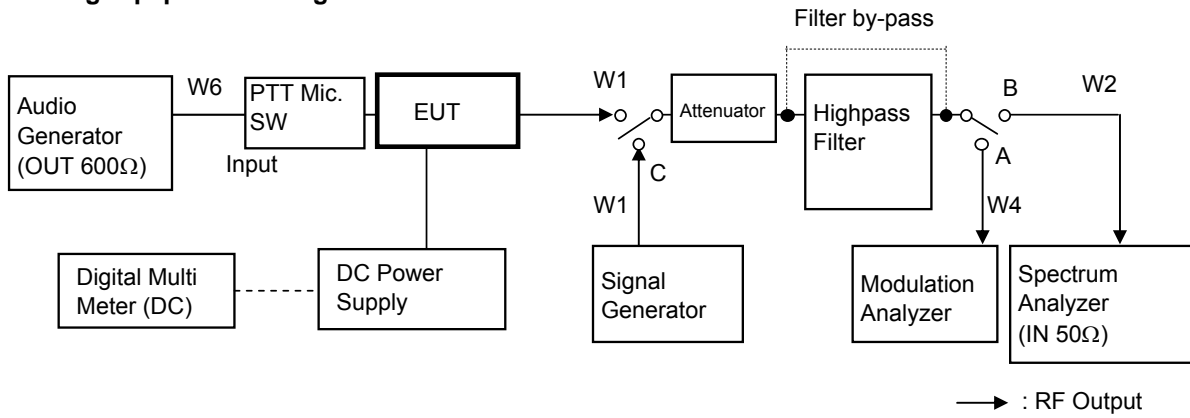

Test Results

Test date	May 25, 2013	to	May 26, 2013
Location	Kashima No.1 Test Site		
temperature	23.2 to 23.2	[degree C]	
Humidity Variation	51 to 54	[%]	
Atmospheric Pressure	99.8 to 100.3	[kPa]	
Test Engineer	Koichi Wagatsuma		

Test was carried out for all the frequency band of section 10.1
 State the worst case (below).

State : High Power / Authorized Bandwidth 6 kHz

Tuned No.	Frequency (MHz)	Band	Spurious Frequency (MHz)	Correct Level (dBm)	Emission Level (dBc)	Mask H/G/EA Limit (FCC) (dBc)	Mask D Limit (RSS) (dBc)	Min. Margin (dB)
1	806.05	(Band 1) Low	2418.15	-47.00	-88.76	-54.8	-61.8	27.0
2	815.05	(Band 1) Middle	2445.15	-47.00	-88.76	-54.8	-61.8	27.0
3	823.95	(Band 1) High	2471.85	-46.00	-87.76	-54.8	-61.8	26.0
4	851.05	(Band 2) Low	No Point detected	-	-	-54.8	-61.8	-
5	860.05	(Band 2) Middle	3440.20	-48.00	-89.76	-54.8	-61.8	28.0
6	868.95	(Band 2) High	3475.80	-41.00	-82.76	-54.8	-61.8	21.0

There is the margin of 20dB over except for the above points.

Mask H/G/EA Limit(dBc)=- $(43+10\log(P))$
 Mask D Limit (dBc) = - $(50+10\log(P))$
 Correct Level (dBm) = Substitute SG Level (dBm)
 Emission Level (dBc) = Correct Level (dBm) - $10\log(P*1000)$
 P = Carrier Level (W)
 " - " = Measurement Limit

State : Low Power / Authorized Bandwidth 6 kHz

Tuned No.	Frequency (MHz)	Band	Spurious Frequency (MHz)	Correct Level (dBm)	Emission Level (dBc)	Mask H/G/EA Limit (FCC) (dBc)	Mask D Limit (RSS) (dBc)	Min. Margin (dB)
1	806.05	(Band 1) Low	No Point detected	-	-	-50.0	-57.0	-
2	815.05	(Band 1) Middle	2445.15	-48.00	-84.99	-50.0	-57.0	28.0
3	823.95	(Band 1) High	No Point detected	-	-	-50.0	-57.0	-
4	851.05	(Band 2) Low	No Point detected	-	-	-50.0	-57.0	-
5	860.05	(Band 2) Middle	No Point detected	-	-	-50.0	-57.0	-
6	868.95	(Band 2) High	No Point detected	-	-	-50.0	-57.0	-

There is the margin of 20dB over except for the above points.

Mask H/G/EA Limit(dBc)=- $(43+10\log(P))$
 Mask D Limit (dBc) = - $(50+10\log(P))$
 Correct Level (dBm) = Substitute SG Level (dBm)
 Emission Level (dBc) = Correct Level (dBm) - $10\log(P*1000)$
 P = Carrier Level (W)
 " - " = Measurement Limit

10.3 Field Strength of Spurious Radiation

REGULATIONS : FCC Part 2 Section 1053 (a), Part 90 Section 210 / RSS-119 Section 5.8

TEST METHOD/GUIDE : ANSI/TIA-603-D Section 2.2.12.2 / RSS-119 Section 4.2, RSS-Gen Section 4.9

Test Procedure

- 1 The EUT and test equipment were set up as shown on the following page.
- 2 Adjust the spectrum analyzer for the following setting:
 - a) RBW : 10 kHz (< 1 GHz), 1 MHz (> 1 GHz).
 - b) VBW : 300 kHz (< 1 GHz), 3 MHz (> 1 GHz).
 - c) Sweep Speed : 50ms.
 - d) Detector mode : Positive Peak
- 3 The transmitter was placed on a wooden turntable, and it was transmitting into non-radiating load which was also placed on the turntable.
- 4 The measurement antenna was placed at a distance of 3 meters from the EUT. During the tests, the antenna height and polarization as well as EUT azimuth were varied in order to identify the maximum level of emissions from the EUT. The test was performed by placing the EUT on 3-orthogonal axis.
- 5 The frequency range up to tenth harmonic of the fundamental frequency was investigated.
- 6 Remove the EUT and replace it with substitution antenna. A signal generator was connected to the substitution antenna by a non-radiating cable. The absolute levels of the spurious emissions were measured by the substitution.
- 7 Spurious emissions in dB = 10 Log (TX power in Watts/0.001) – the absolute level

Measuring Equipments

No.	Equipment	Manufacture	Model No.	Serial No.	Cal Date	Cal Exp.
1	D.R.G Antenna(TX)	ETS LINDGREN	3117	00055157	Aug. 14, 12	Aug. 31, 13
2	D.R.G Antenna(RX)	EMCO	3115	5044	Jul. 03, 12	Jul. 31, 13
3	Attenuator(10dB)	HUBER+SUHNER	6810.17B	KSR0044	May 09, 12	May 31, 13
4	Attenuator(3dB)	SUHNER	6803.17.B	None	Oct. 02, 12	Oct. 31, 13
5	Amplifier	TOYO	TPA0118-30	0402	Oct. 02, 12	Oct. 31, 13
6	Signal Generator	Rohde&Schwarz	SMP02	845275/007	Jan. 24, 13	Jan. 31, 14
7	Spectrum Analyzer	Agilent	N9030A	US51350170	Jan. 25, 13	Jan. 31, 14
8	Dummy Load	TME	CT-150NP	1138693	Dec. 20, 12	Dec. 31, 13
9	Digital Multi Meter	FLUKE	8846A	9642018	May 11, 12	May 31, 13
10	DC Power Supply	Daiichi denpa kogyo	GZV4000	90290931	None	None

Measuring Cables

No.	Cable	Manufacturer	Model No.	Serial No.	Cal Date	Cal Exp.
W1	Coaxial Cable	Suhner	SUCOFLEX104	KSR00091	May 09, 12	May 31, 13
W13	Coaxial Cable	Suhner	SUCOFLEX106	KSR00207	May 09, 12	May 31, 13
R12	Coaxial Cable	RADIALL	R286401343	03 23 104	Oct. 02, 12	Oct. 31, 13
R11	Coaxial Cable	RADIALL	R286401344	03 23 72	Oct. 02, 12	Oct. 31, 13

Measuring Equipment Configuration

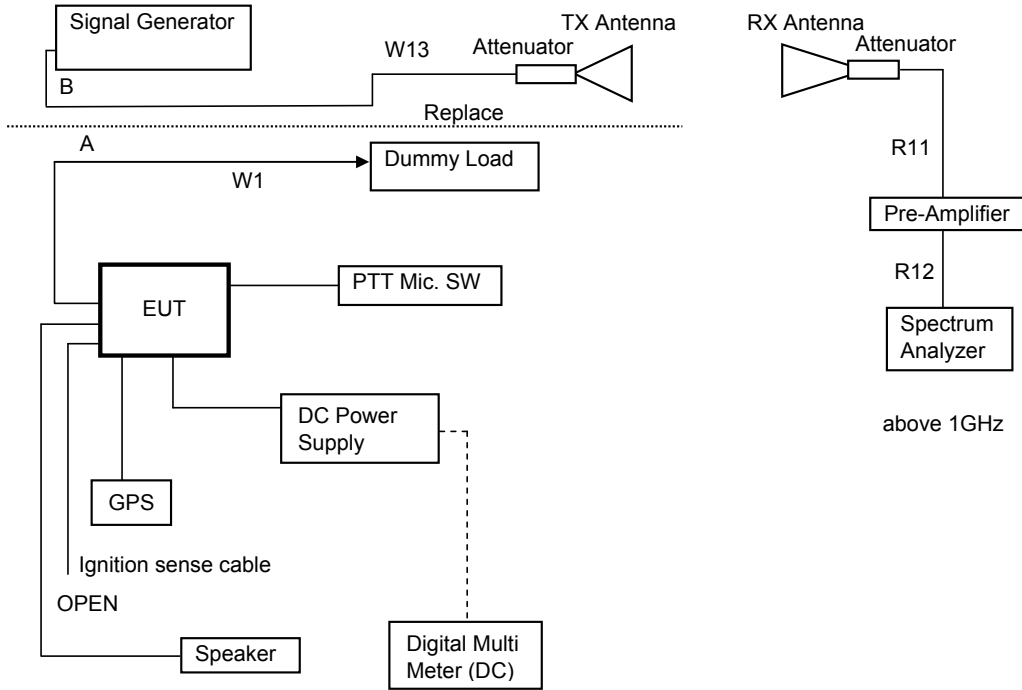

→ : RF Output

Test Results

Test date	May 01, 2013	to	May 02, 2013
Location	Kashima No.12 Test Site		
temperature	20.5 to 23.0	[degree C]	
Humidity Variation	50 to 53	[%]	
Atmospheric Pressure	99.5 to 100.2	[kPa]	
Test Engineer	Koichi Wagatsuma		

Test was carried out for all the frequency band of section 10.1
 State the worst case (below).

State : High Power / Authorized Bandwidth 6 kHz / 815.05MHz (Band 1)(FCC/RSS)

No	Frequency (MHz)	Pol	Reading Level (dBm)	SG Out Level (dBm)	Antenna Gain (dBi)	Loss (dB)	Correct Level (dBm)	Emission Level (dBc)	MASK H/G/EA Limit Level (FCC) (dBc)	MASK D Limit Level (RSS) (dBc)	Min. Margin (dB)
1	1630.10	Hor.	-42.64	-32.90	5.97	13.17	-40.1	-81.9	-54.8	-61.8	20.1
		Ver.	-43.84	-32.00	5.97	13.17	-39.2	-81.0	-54.8	-61.8	19.2
2	2445.15	Hor.	-60.01	-49.60	5.55	13.95	-58.0	-99.8	-54.8	-61.8	38.0
		Ver.	-55.00	-41.00	5.55	13.95	-49.4	-91.2	-54.8	-61.8	29.4
3	3260.20	Hor.	-58.68	-45.20	7.61	14.60	-52.2	-94.0	-54.8	-61.8	32.2
		Ver.	-56.93	-41.70	7.61	14.60	-48.7	-90.5	-54.8	-61.8	28.7
4	4075.25	Hor.	-52.70	-37.00	8.60	15.18	-43.6	-85.3	-54.8	-61.8	23.5
		Ver.	-50.07	-32.40	8.60	15.18	-39.0	-80.7	-54.8	-61.8	18.9
5	4890.30	Hor.	-49.71	-31.20	9.61	15.72	-37.3	-79.1	-54.8	-61.8	17.3
		Ver.	-50.38	-32.20	9.61	15.72	-38.3	-80.1	-54.8	-61.8	18.3
6	5705.35	Hor.	-50.62	-30.10	10.40	16.19	-35.9	-77.6	-54.8	-61.8	15.8
		Ver.	-49.04	-28.90	10.40	16.19	-34.7	-76.4	-54.8	-61.8	14.6
7	6520.40	Hor.	-	-	10.72	16.71	-	-	-54.8	-61.8	-
		Ver.	-61.55	-42.60	10.72	16.71	-48.6	-90.4	-54.8	-61.8	28.6
8	7335.45	Hor.	-	-	11.58	17.21	-	-	-54.8	-61.8	-
		Ver.	-	-	11.58	17.21	-	-	-54.8	-61.8	-
9	8150.50	Hor.	-	-	12.36	17.60	-	-	-54.8	-61.8	-
		Ver.	-	-	12.36	17.60	-	-	-54.8	-61.8	-

There is the margin of 20dB over except for the above points.

Mask H/G/EA Limit (dBc) = -(43+10Log(P))

Mask D Limit (dBc) = -(50+10Log(P))

Correct Level (dBm) = Substitute SG Level (dBm) + ANT Gain (dBi) - Loss (Cable, Attenuator) (dB)

Emission Level (dBc) = Correct Level (dBm) - 10Log(P*1000)

P = Carrier Level (W)

" - " = Measurement Limit

State : Low Power / Authorized Bandwidth 6 kHz / 815.05MHz (Band 1)(FCC/RSS)

No	Frequency (MHz)	Pol	Reading Level (dBm)	SG Out Level (dBm)	Antenna Gain (dBi)	Loss (dB)	Correct Level (dBm)	Emission Level (dBc)	MASK H/G/EA Limit (FCC) (dBc)	MASK D Limit (RSS) (dBc)	Min. Margin (dB)
1	1630.10	Hor.	-45.27	-35.40	5.97	13.17	-42.6	-79.6	-50.0	-57.0	22.6
		Ver.	-47.18	-35.70	5.97	13.17	-42.9	-79.9	-50.0	-57.0	22.9
2	2445.15	Hor.	-57.93	-46.60	5.55	13.95	-55.0	-92.0	-50.0	-57.0	35.0
		Ver.	-54.38	-40.30	5.55	13.95	-48.7	-85.7	-50.0	-57.0	28.7
3	3260.20	Hor.	-	-	7.61	14.60	-	-	-50.0	-57.0	-
		Ver.	-	-	7.61	14.60	-	-	-50.0	-57.0	-
4	4075.25	Hor.	-57.00	-42.50	8.60	15.18	-49.1	-86.1	-50.0	-57.0	29.1
		Ver.	-56.61	-40.30	8.60	15.18	-46.9	-83.9	-50.0	-57.0	26.9
5	4890.30	Hor.	-54.51	-37.00	9.61	15.72	-43.1	-80.1	-50.0	-57.0	23.1
		Ver.	-54.74	-37.60	9.61	15.72	-43.7	-80.7	-50.0	-57.0	23.7
6	5705.35	Hor.	-60.08	-42.40	10.40	16.19	-48.2	-85.2	-50.0	-57.0	28.2
		Ver.	-59.28	-41.50	10.40	16.19	-47.3	-84.3	-50.0	-57.0	27.3
7	6520.40	Hor.	-	-	10.72	16.71	-	-	-50.0	-57.0	-
		Ver.	-	-	10.72	16.71	-	-	-50.0	-57.0	-
8	7335.45	Hor.	-	-	11.58	17.21	-	-	-50.0	-57.0	-
		Ver.	-	-	11.58	17.21	-	-	-50.0	-57.0	-
9	8150.50	Hor.	-	-	12.36	17.60	-	-	-50.0	-57.0	-
		Ver.	-	-	12.36	17.60	-	-	-50.0	-57.0	-

There is the margin of 20dB over except for the above points.

Mask H/G/EA Limit (dBc) = $-(43+10\log(P))$ Mask D Limit (dBc) = $-(50+10\log(P))$

Correct Level (dBm) = Substitute SG Level (dBm) + ANT Gain (dBi) - Loss (Cable, Attenuator) (dB)

Emission Level (dBc) = Correct Level (dBm) - $10\log(P*1000)$

P = Carrier Level (W)

" - " = Measurement Limit

State : High Power / Authorized Bandwidth 6kHz / 868.95MHz (Band 2)(RSS)

No	Frequency (MHz)	Pol	Reading Level (dBm)	SG Out Level (dBm)	Antenna Gain (dBi)	Loss (dB)	Correct Level (dBm)	Emission Level (dBc)	MASK H/G/EA Limit (FCC) (dBc)	MASK D Limit (RSS) (dBc)	Min. Margin (dB)
1	1737.90	Hor.	-49.30	-37.60	5.24	13.28	-45.6	-87.4	-54.8	-61.8	25.6
		Ver.	-45.90	-33.00	5.24	13.28	-41.0	-82.8	-54.8	-61.8	21.0
2	2606.85	Hor.	-52.96	-39.50	6.07	14.09	-47.5	-89.3	-54.8	-61.8	27.5
		Ver.	-51.00	-36.10	6.07	14.09	-44.1	-85.9	-54.8	-61.8	24.1
3	3475.80	Hor.	-50.25	-35.20	8.05	14.77	-41.9	-83.7	-54.8	-61.8	21.9
		Ver.	-50.51	-33.90	8.05	14.77	-40.6	-82.4	-54.8	-61.8	20.6
4	4344.75	Hor.	-55.40	-39.60	9.17	15.36	-45.8	-87.6	-54.8	-61.8	25.8
		Ver.	-48.21	-31.00	9.17	15.36	-37.2	-79.0	-54.8	-61.8	17.2
5	5213.70	Hor.	-49.87	-30.40	9.80	15.91	-36.5	-78.3	-54.8	-61.8	16.5
		Ver.	-44.36	-25.30	9.80	15.91	-31.4	-73.2	-54.8	-61.8	11.4
6	6082.65	Hor.	-57.00	-37.00	10.42	16.41	-43.0	-84.8	-54.8	-61.8	23.0
		Ver.	-53.87	-33.40	10.42	16.41	-39.4	-81.2	-54.8	-61.8	19.4
7	6951.60	Hor.	-61.20	-39.20	11.18	17.01	-45.0	-86.8	-54.8	-61.8	25.0
		Ver.	-58.15	-36.90	11.18	17.01	-42.7	-84.5	-54.8	-61.8	22.7
8	7820.55	Hor.	-59.41	-36.50	12.08	17.45	-41.9	-83.6	-54.8	-61.8	21.8
		Ver.	-58.70	-36.90	12.08	17.45	-42.3	-84.0	-54.8	-61.8	22.2
9	8689.50	Hor.	-	-	12.80	17.81	-	-	-54.8	-61.8	-
		Ver.	-	-	12.80	17.81	-	-	-54.8	-61.8	-

There is the margin of 20dB over except for the above points.

Mask H/G/EA Limit (dBc) = $-(43+10\log(P))$ Mask D Limit (dBc) = $-(50+10\log(P))$

Correct Level (dBm) = Substitute SG Level (dBm) + ANT Gain (dBi) - Loss (Cable, Attenuator) (dB)

Emission Level (dBc) = Correct Level (dBm) - $10\log(P*1000)$

P = Carrier Level (W)

" - " = Measurement Limit

State : Low Power / Authorized Bandwidth 6 kHz / 868.95MHz (Band 2)(RSS)

No	Frequency (MHz)	Pol	Reading Level (dBm)	SG Out Level (dBm)	Antenna Gain (dBi)	Loss (dB)	Correct Level (dBm)	Emission Level (dBc)	MASK H/G/EA Limit (FCC) (dBc)	MASK D Limit (RSS) (dBc)	Min. Margin (dB)
1	1737.90	Hor.	-49.60	-37.80	5.24	13.28	-45.8	-82.8	-50.0	-57.0	25.8
		Ver.	-46.45	-33.50	5.24	13.28	-41.5	-78.5	-50.0	-57.0	21.5
2	2606.85	Hor.	-51.25	-37.70	6.07	14.09	-45.7	-82.7	-50.0	-57.0	25.7
		Ver.	-47.99	-32.80	6.07	14.09	-40.8	-77.8	-50.0	-57.0	20.8
3	3475.80	Hor.	-59.51	-47.30	8.05	14.77	-54.0	-91.0	-50.0	-57.0	34.0
		Ver.	-59.38	-45.60	8.05	14.77	-52.3	-89.3	-50.0	-57.0	32.3
4	4344.75	Hor.	-54.50	-38.60	9.17	15.36	-44.8	-81.8	-50.0	-57.0	24.8
		Ver.	-54.20	-37.90	9.17	15.36	-44.1	-81.1	-50.0	-57.0	24.1
5	5213.70	Hor.	-52.17	-33.10	9.80	15.91	-39.2	-76.2	-50.0	-57.0	19.2
		Ver.	-48.01	-29.00	9.80	15.91	-35.1	-72.1	-50.0	-57.0	15.1
6	6082.65	Hor.	-57.89	-38.40	10.42	16.41	-44.4	-81.4	-50.0	-57.0	24.4
		Ver.	-56.03	-36.00	10.42	16.41	-42.0	-79.0	-50.0	-57.0	22.0
7	6951.60	Hor.	-	-	11.18	17.01	-	-	-50.0	-57.0	-
		Ver.	-	-	11.18	17.01	-	-	-50.0	-57.0	-
8	7820.55	Hor.	-	-	12.08	17.45	-	-	-50.0	-57.0	-
		Ver.	-	-	12.08	17.45	-	-	-50.0	-57.0	-
9	8689.50	Hor.	-	-	12.80	17.81	-	-	-50.0	-57.0	-
		Ver.	-	-	12.80	17.81	-	-	-50.0	-57.0	-

There is the margin of 20dB over except for the above points.

Mask H/G/EA Limit (dBc) = $-(43+10\log(P))$

Mask D Limit (dBc) = $-(50+10\log(P))$

Correct Level (dBm) = Substitute SG Level (dBm) + ANT Gain (dBi) - Loss (Cable, Attenuator) (dB)

Emission Level (dBc) = Correct Level (dBm) - $10\log(P*1000)$

P = Carrier Level (W)

" - " = Measurement Limit

10.4 Emission Masks (Occupied Bandwidth)

REGULATIONS	: FCC Part 2 Section 1049 (c) (1), Part 90 Section 210 / RSS-119 Section 5.8
TEST METHOD/GUIDE	: ANSI/TIA-603-D Section 2.2.11.2 / RSS-119 Section 4.2.1, 4.2.2

Test Procedure

- 1 The EUT and test equipment were set up as shown on the following page.
- 2 For EUT supporting audio modulation, the audio signal generator was adjusted to the frequency of maximum response and with output level set for +/- 2.5 kHz deviation (or 50 % modulation). (FM modulation).
- 3 With level constant, the signal level was increased 16 dB.
- 4 For EUT supporting digital modulation, the digital modulation mode was operated to its maximum extent.
- 5 Adjust the spectrum analyzer for the following setting:
 - a) RBW : 100Hz (Non modulation (FM modulation). , Mask D),
300Hz (Non modulation (FM modulation). , Mask B, EA, H, G)
 - b) VBW : 10times the RBW
 - c) RBW and VBW : 30 kHz (Non Modulation (Digital Modulation)).
 - d) Sweep Speed : 8 sec.
 - e) Sampling Time : 10 times
- 6 The occupied Bandwidth was measured with the Spectrum Analyzer controls set as shown on the test results.

Measuring Equipments

No.	Equipment	Manufacture	Model No.	Serial No.	Cal Date	Cal Exp.
1	Attenuator (20dB)	Aeroflex/Wenschel	66-20-34	BY4357	May 09, 12	May 31, 13
2	Attenuator (30dB)	Weinschel	WA-29-30-34	8923	May 09, 12	May 31, 13
3	Audio Generator	Anritsu	MG443B	M70150	Apr. 05, 13	Apr. 30, 14
4	Modulation Analyzer	Hewlett Packard	8901B	3403A04852	Aug. 09, 12	Aug. 31, 13
5	Spectrum Analyzer	Agilent	E4407B	MY45102460	Apr. 06, 13	Apr. 30, 14
6	Spectrum Analyzer	HP	8563E	3821A09565	Apr. 08, 13	Apr. 30, 14
7	Digital Multi Meter	FLUKE	8846A	9642018	May 11, 12	May 31, 13
8	DC Power Supply	Daiichi denpa kogyo	GZV4000	90290931	None	None
9	JIG	HP	Compaq 6710b	CNU7361PTS	None	None

Measuring Cables

No.	Cable	Manufacture	Model No.	Serial No.	Cal Date	Cal Exp.
W1	Coaxial Cable	Suhner	SUCOFLEX104	KSR00211	Dec. 20, 12	Dec. 31, 13
W2	Coaxial Cable	Suhner	SUCOFLEX104	F0000017	Dec. 20, 12	Dec. 31, 13
W4	Coaxial Cable	Pacific custom	RG-58 C/U	KSR00097	Dec. 21, 12	Dec. 31, 13
W6	Balance Cable	Nicoon	3D-2V	KSR00092	Dec. 21, 12	Dec. 31, 13
W20	PROGRAMMING INTERFACE Cable	JVC KENWOOD	KPG46-U	None	None	None

Measuring Equipment Configuration

<FM Modulation Case>

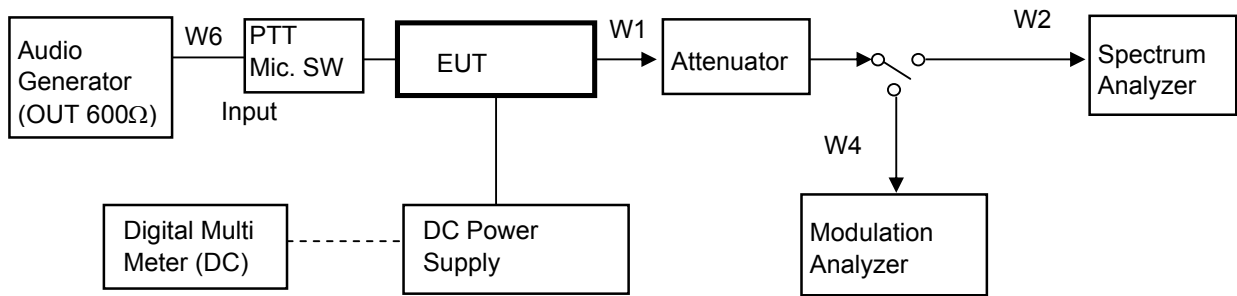

Note: Configuration of other Modulation(4Level FSK) test is composed without the Audio Generator.

→ : RF Output

<CW ID Modulation Case>

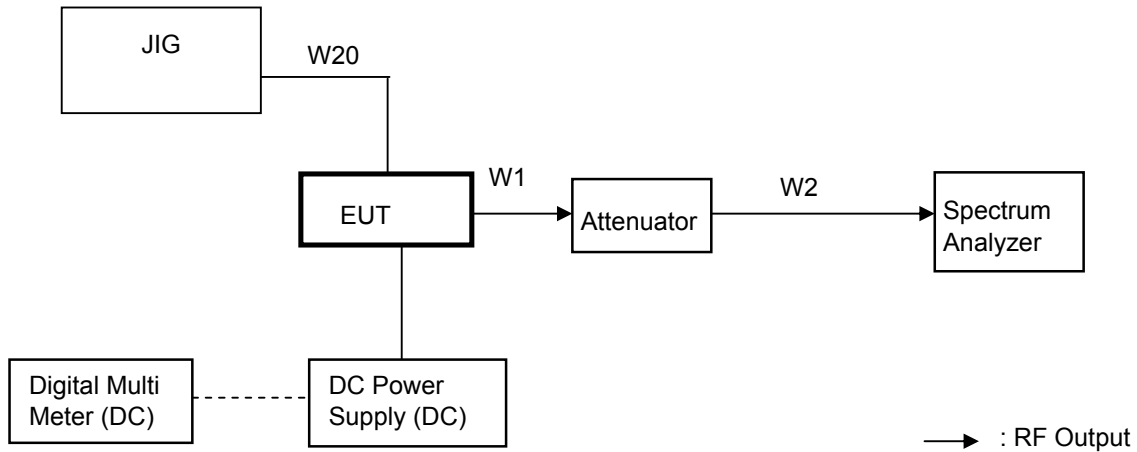

→ : RF Output

Test Results

Test date	May 08, 2013	to	May 22, 2013
Location	Kashima No.1 Test Site		
temperature	20.5 to 24.0	[degree C]	
Humidity Variation	48 to 64	[%]	
Atmospheric Pressure	99.8 to 101.3	[kPa]	
Test Engineer	Koichi Wagatsuma		

Test was carried out for all the frequency band of section 10.1
 State the worst case (below).

State : High Power / Authorized Bandwidth 20 kHz/ 16K0F3E/ 823.95 MHz (FCC/RSS) (Band 1)
 FCC Limit : Mask B, EA RSS Limit : Mask B

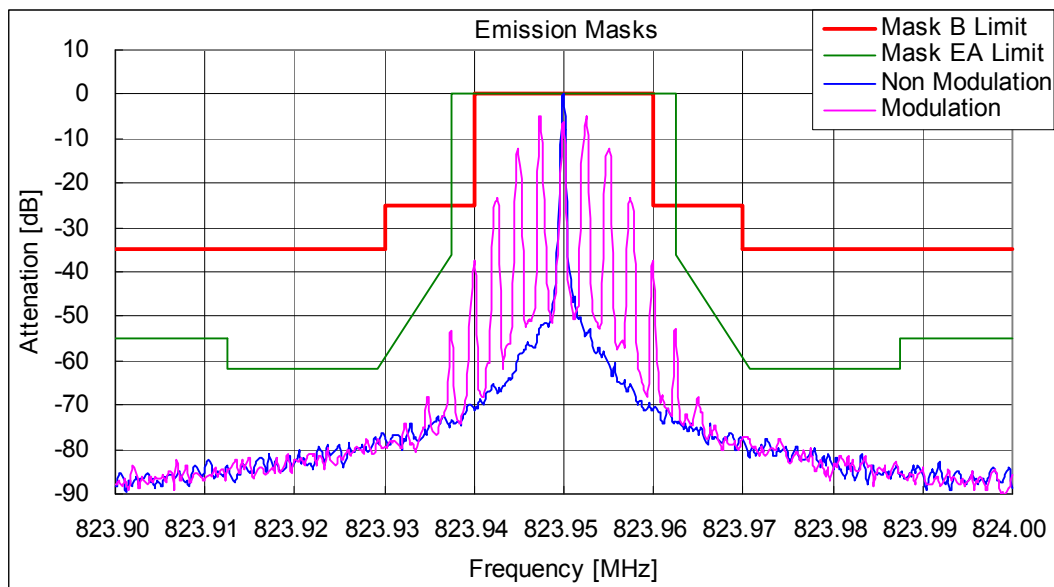

State : High Power / Authorized Bandwidth 20 kHz/ 16K0F3E/ 851.05 MHz (FCC/RSS) (Band 2)
 FCC Limit : Mask B, EA RSS Limit : Mask B

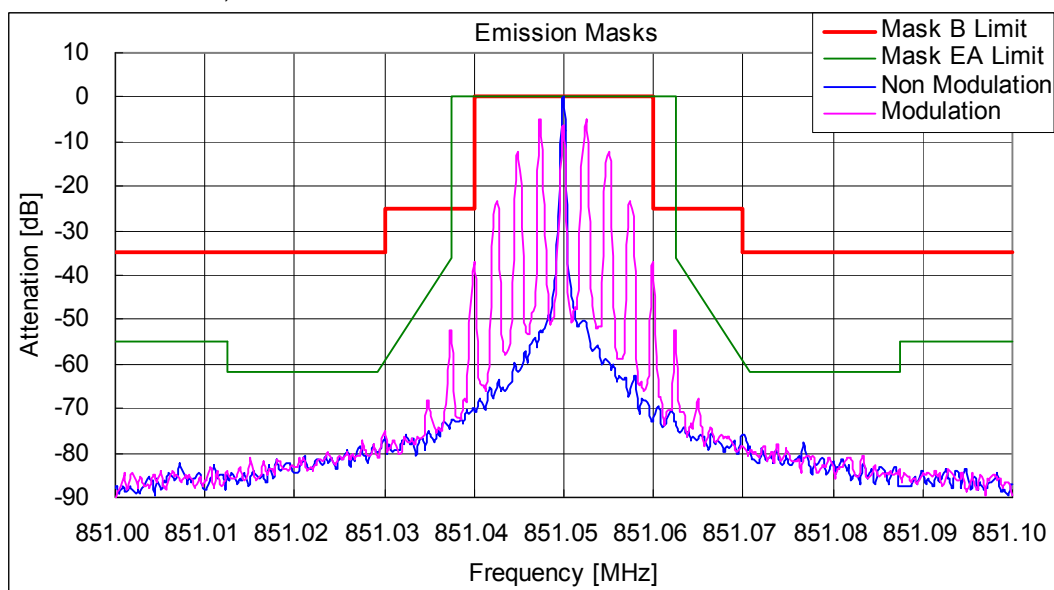

State : High Power / Authorized Bandwidth 20 kHz/ 14K0F3E / 806.05 MHz(FCC/RSS) (Band 1)
FCC Limit : Mask B, EA RSS Limit : Mask B

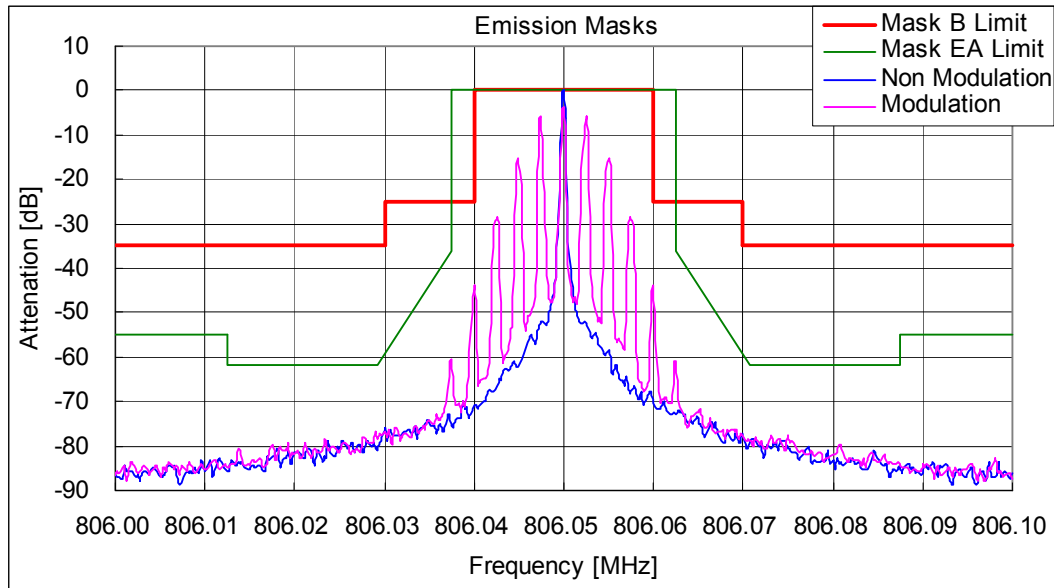

State : High Power / Authorized Bandwidth 20 kHz/ 14K0F3E / 869.95 MHz(FCC/RSS) (Band 2)
FCC Limit : Mask B, EA RSS Limit : Mask B

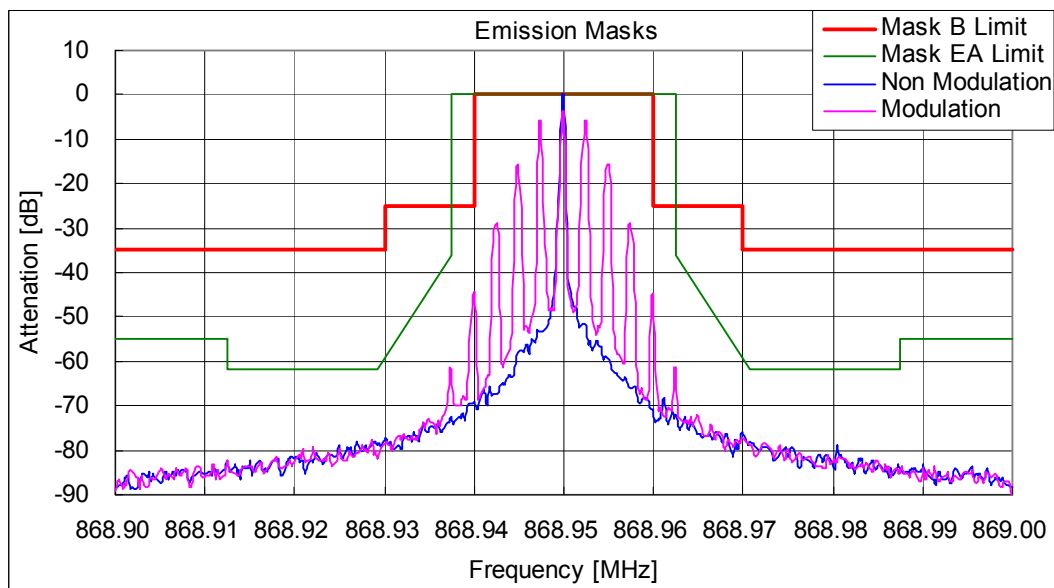

State : High Power / Authorized Bandwidth 11.25 kHz/ 11K0F3E / 823.95 MHz (FCC) (Band 1)
FCC Limit : Mask B, EA

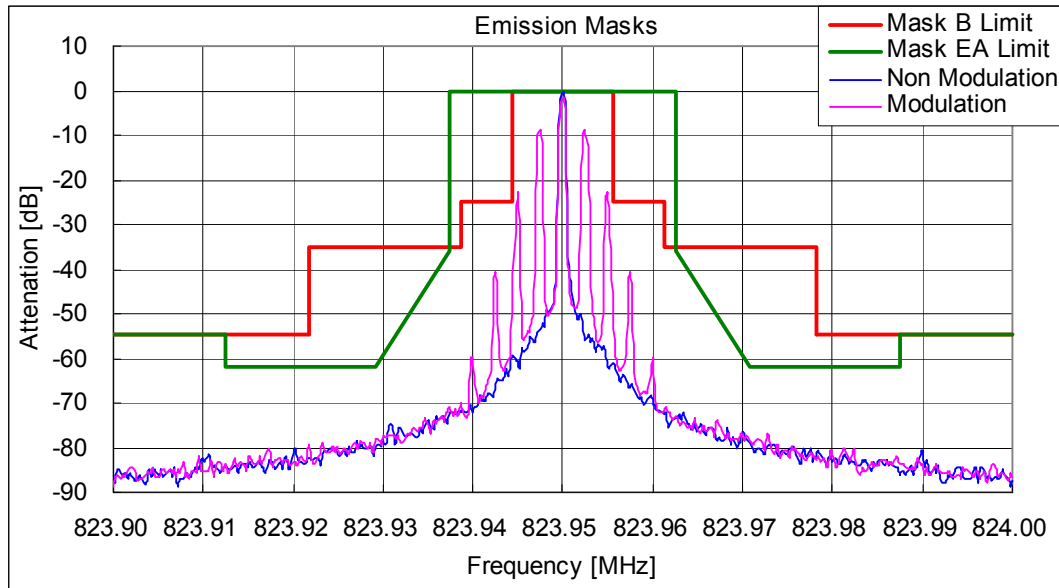

State : High Power / Authorized Bandwidth 11.25 kHz/ 11K0F3E / 815.05 MHz (RSS) (Band 1)
RSS Limit : Mask D

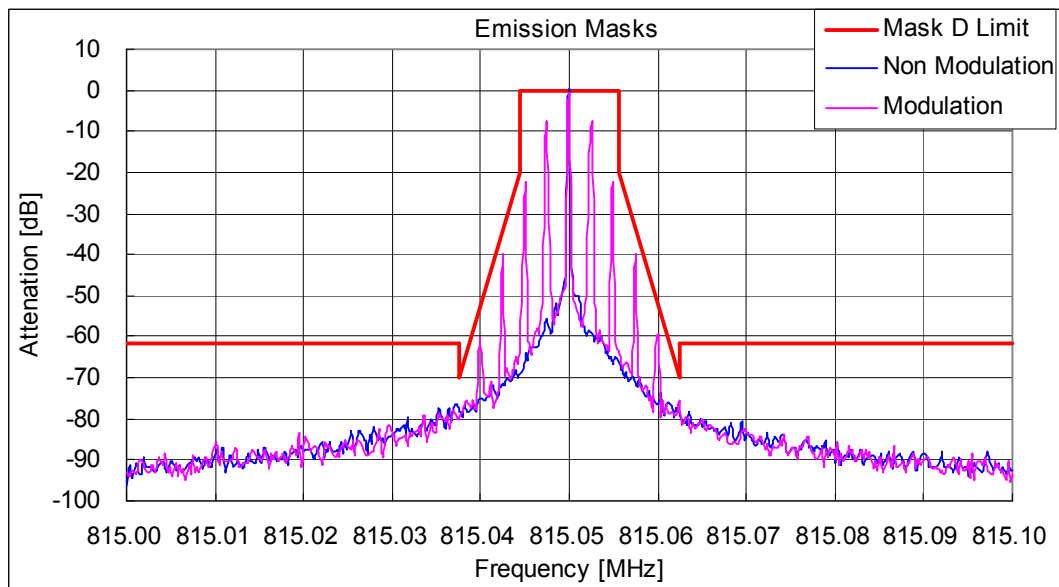

State : High Power / Authorized Bandwidth 11.25 kHz/ 11K0F3E / 851.05 MHz (FCC) (Band 2)
FCC Limit : Mask B, EA

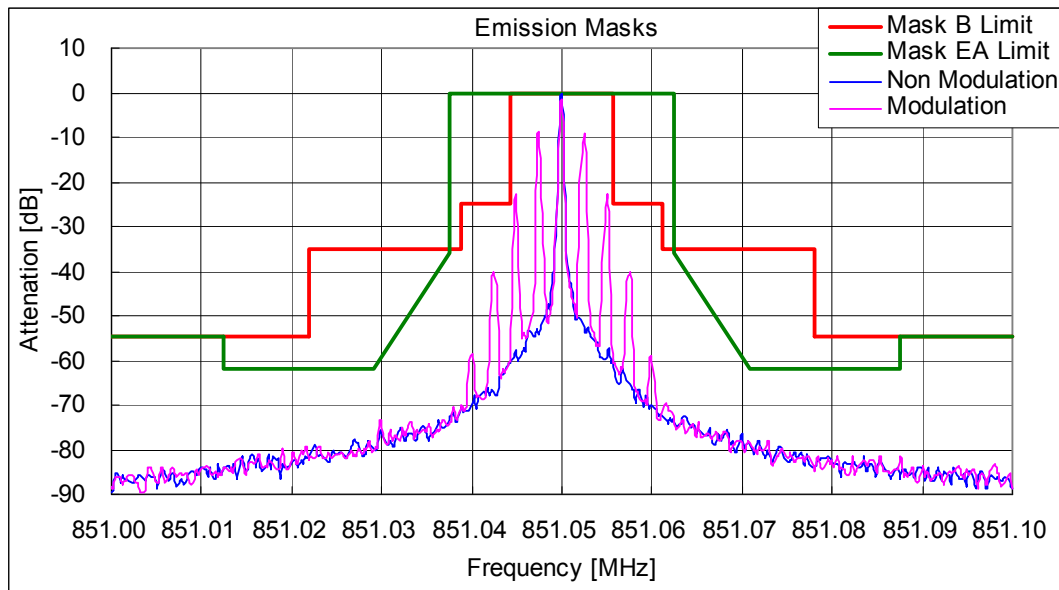

State : High Power / Authorized Bandwidth 11.25 kHz/ 11K0F3E / 868.95 MHz (RSS) (Band 2)
RSS Limit : Mask D

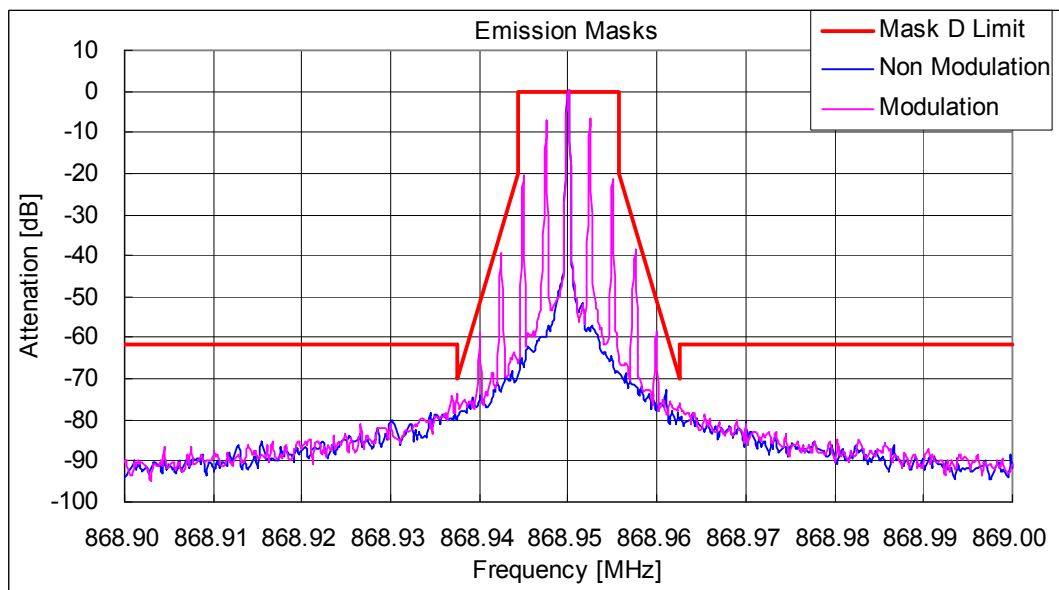

State : High Power / Authorized Bandwidth 11.25 kHz/ 8K30F1E/ F1D/ F7W/ 823.95 MHz (FCC) (Band 1)
FCC Limit : Mask H, G, EA

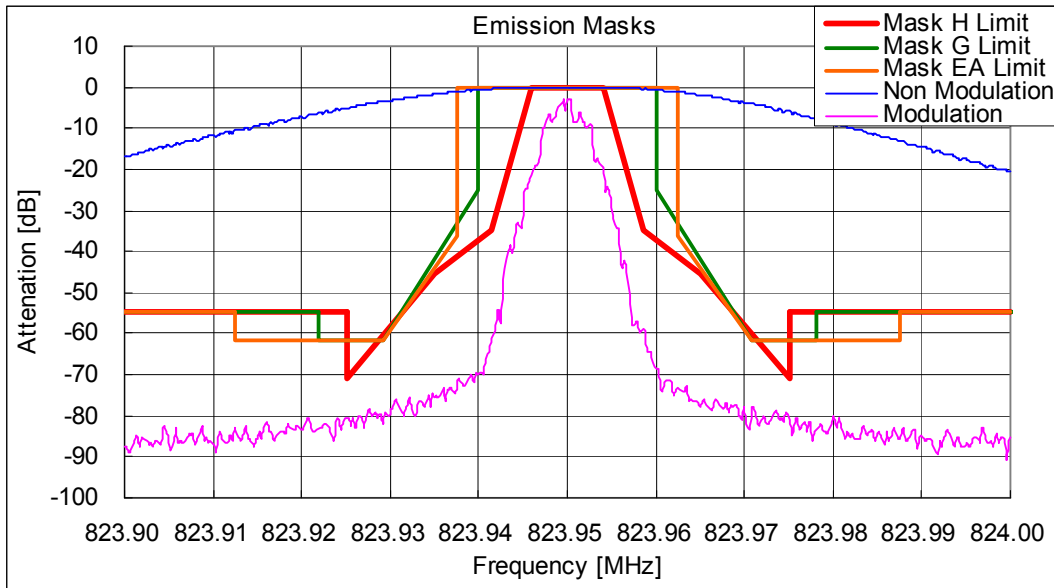

State : High Power / Authorized Bandwidth 11.25 kHz/ 8K30F1E/ F1D/ F7W/ 815.05 MHz (RSS) (Band 1)
RSS Limit : Mask D

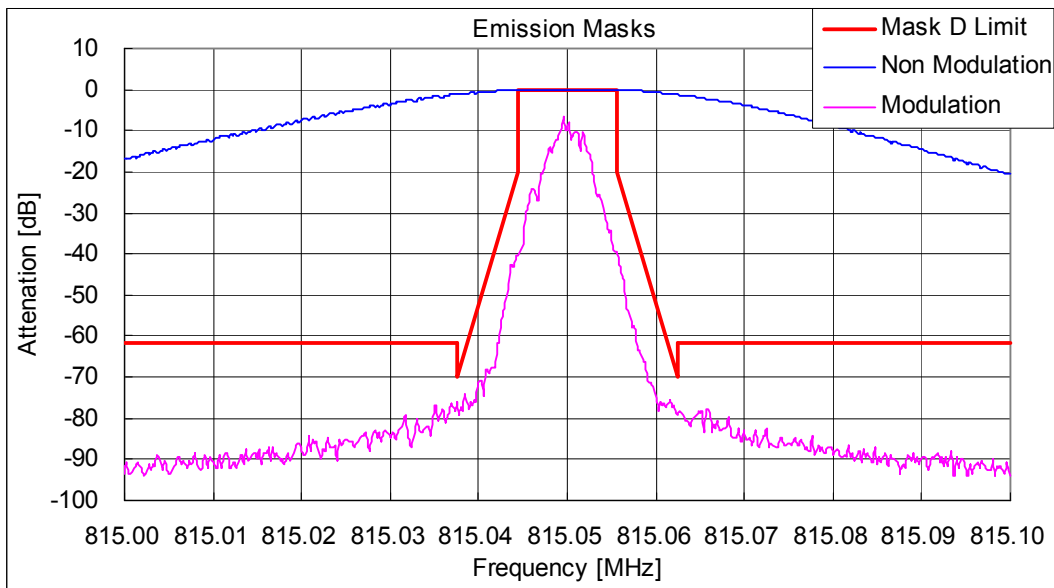

State : High Power / Authorized Bandwidth 11.25 kHz/ 8K30F1E/ F1D/ F7W/ 868.95 MHz (FCC) (Band 2)
FCC Limit : Mask H, G, EA

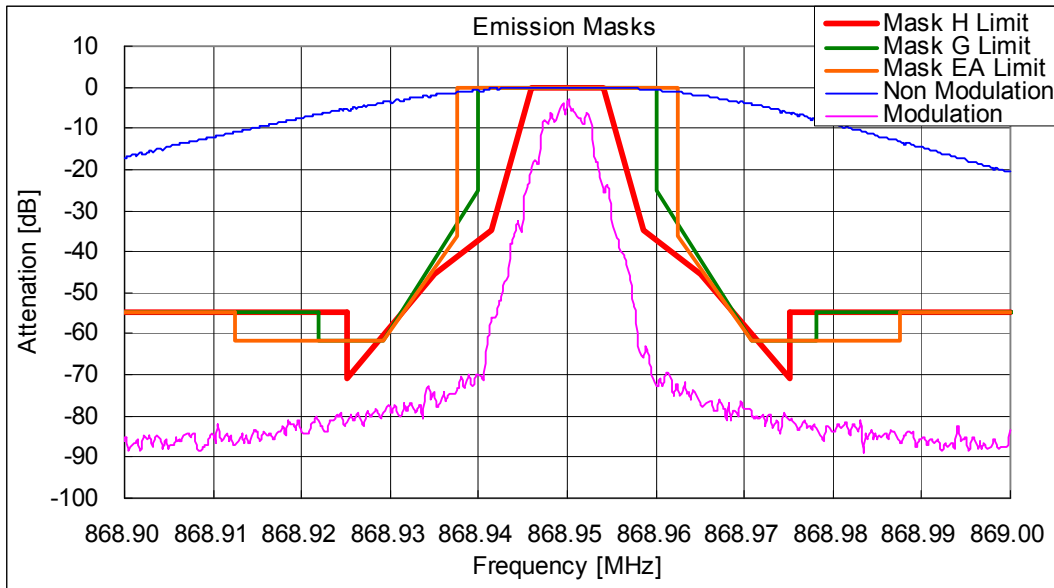

State : High Power / Authorized Bandwidth 11.25 kHz/ 8K30F1E/ F1D/ F7W/ 851.05 MHz (RSS) (Band 2)
RSS Limit : Mask D

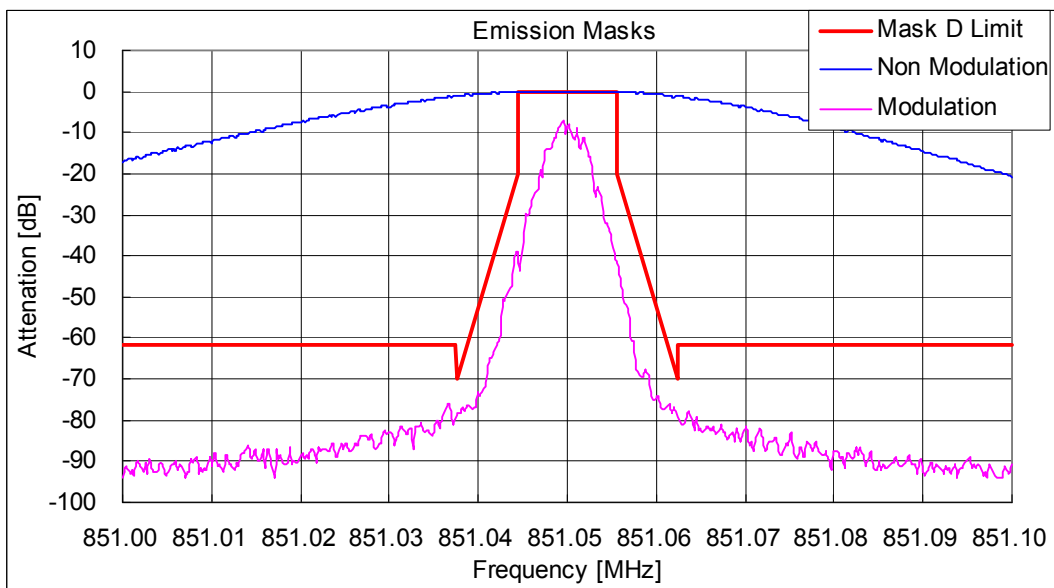

State : High Power / Authorized Bandwidth 6 kHz/ 4K00F1E/ F1D/ F7W/ 806.05 MHz (FCC) (Band 1)
FCC Limit : Mask H, G, EA

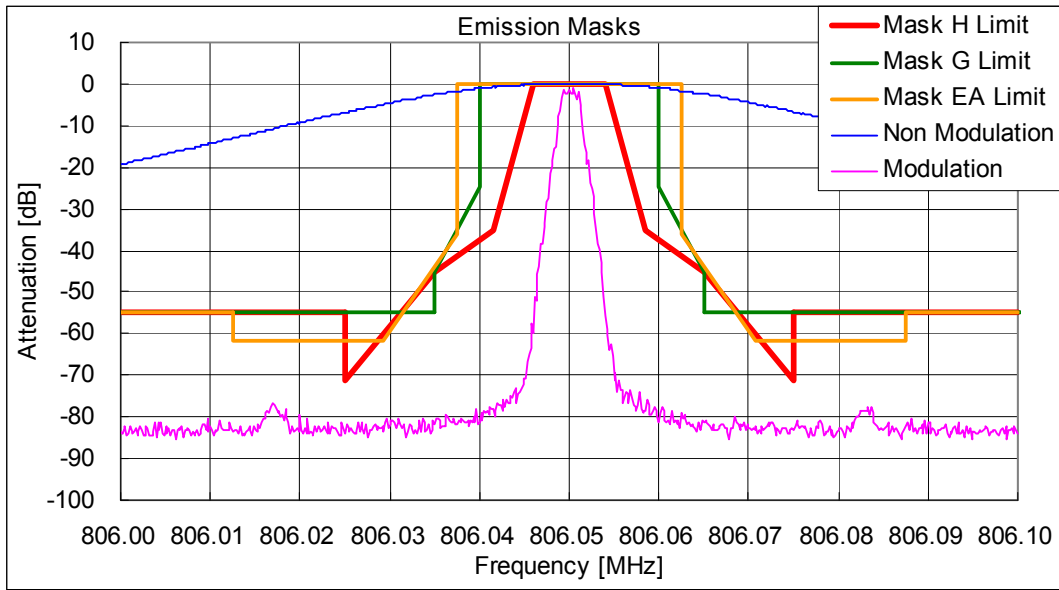

State : High Power / Authorized Bandwidth 6 kHz/ 4K00F1E/ F1D/ F7W/ 815.05 MHz (RSS) (Band 1)
RSS Limit : Mask D

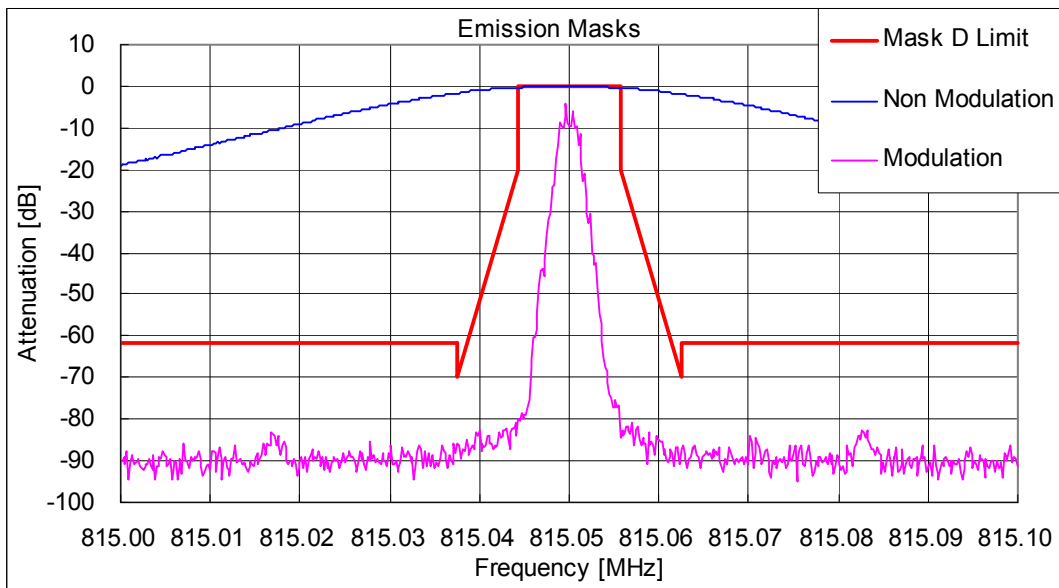

State : High Power / Authorized Bandwidth 6 kHz/ 4K00F1E/ F1D/ F7W/ 868.95 MHz (FCC) (Band 2)
FCC Limit : Mask H, G, EA

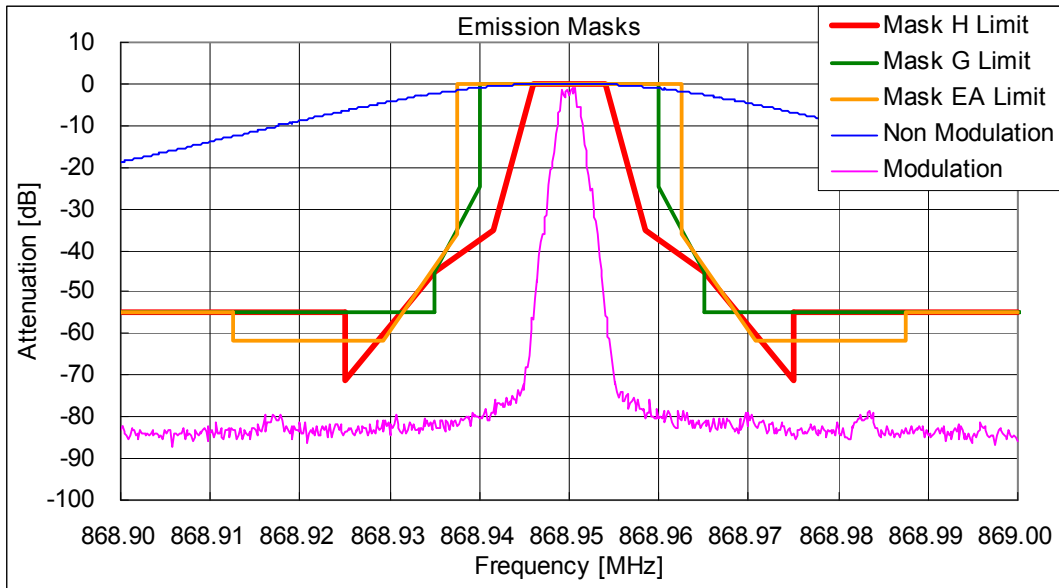

State : High Power / Authorized Bandwidth 6 kHz/ 4K00F1E/ F1D/ F7W/ 860.05 MHz (RSS) (Band 2)
RSS Limit : Mask D

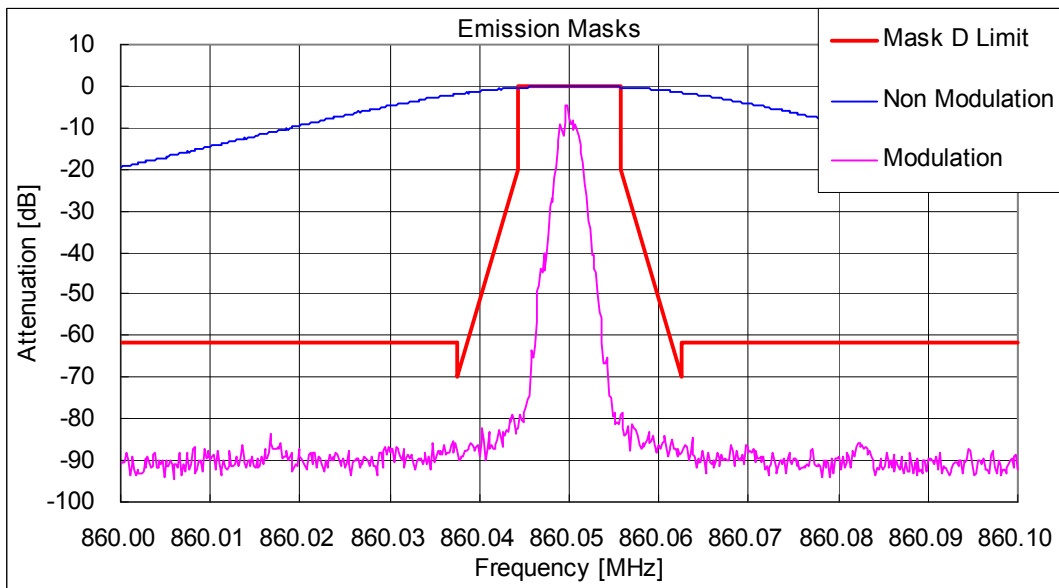

State : High Power / Authorized Bandwidth 6 kHz/ 4K00F2D/ 823.95 MHz (FCC) (Band 1)
FCC Limit : Mask H, G, EA

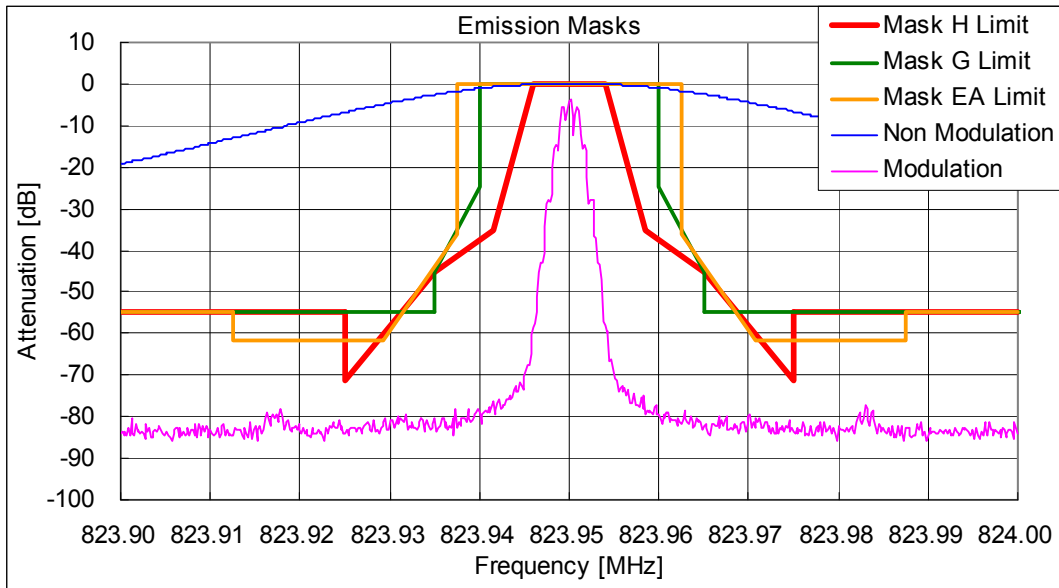

State : High Power / Authorized Bandwidth 6 kHz/ 4K00F2D/ 823.95 MHz (RSS) (Band 1)
RSS Limit : Mask D

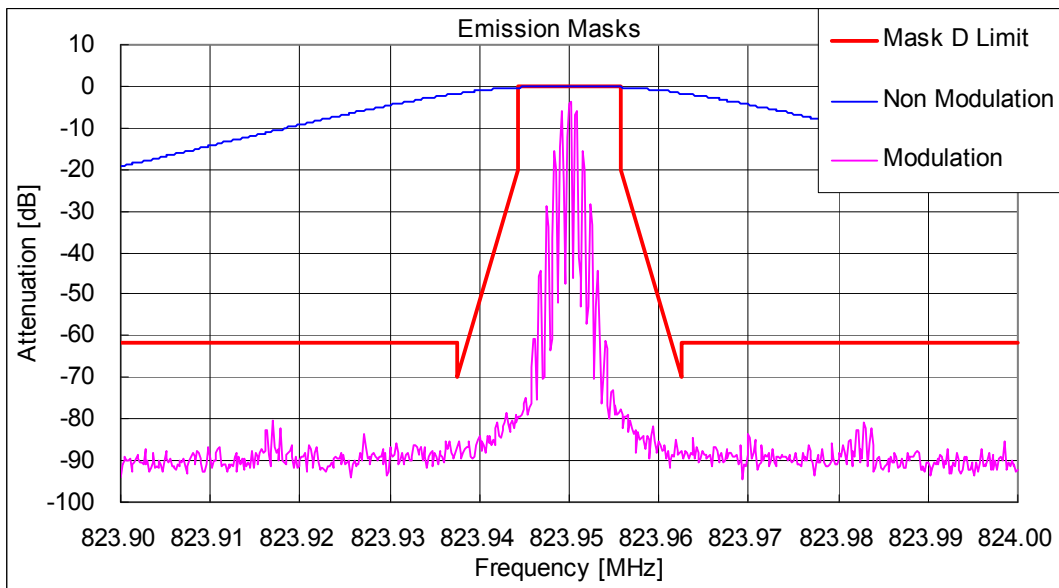

State : High Power / Authorized Bandwidth 6 kHz/ 4K00F2D/ 860.05 MHz (FCC) (Band 2)
FCC Limit : Mask H, G, EA

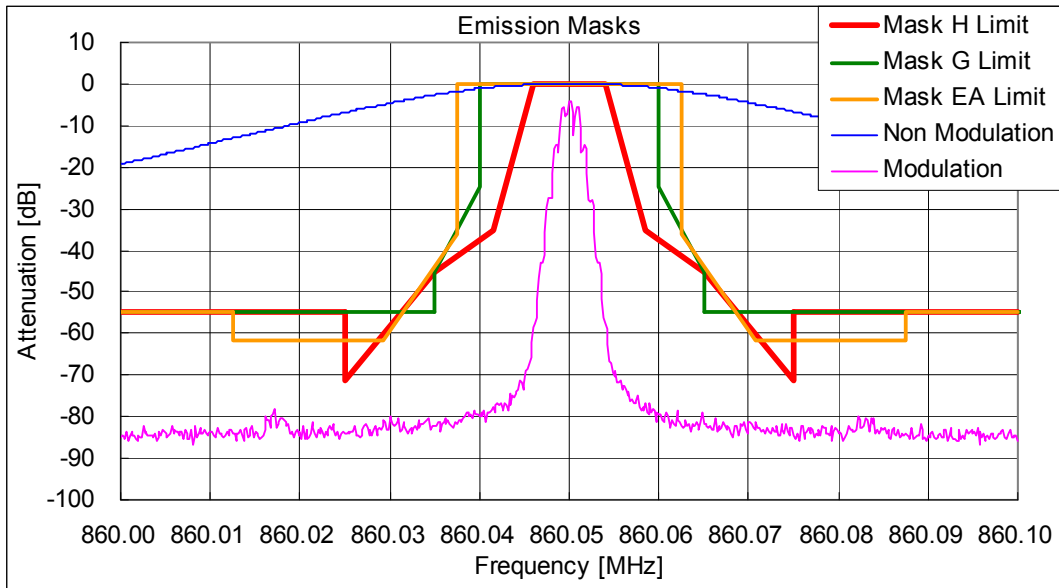

State : High Power / Authorized Bandwidth 6 kHz/ 4K00F2D/ 860.05 MHz (RSS) (Band 2)
RSS Limit : Mask D

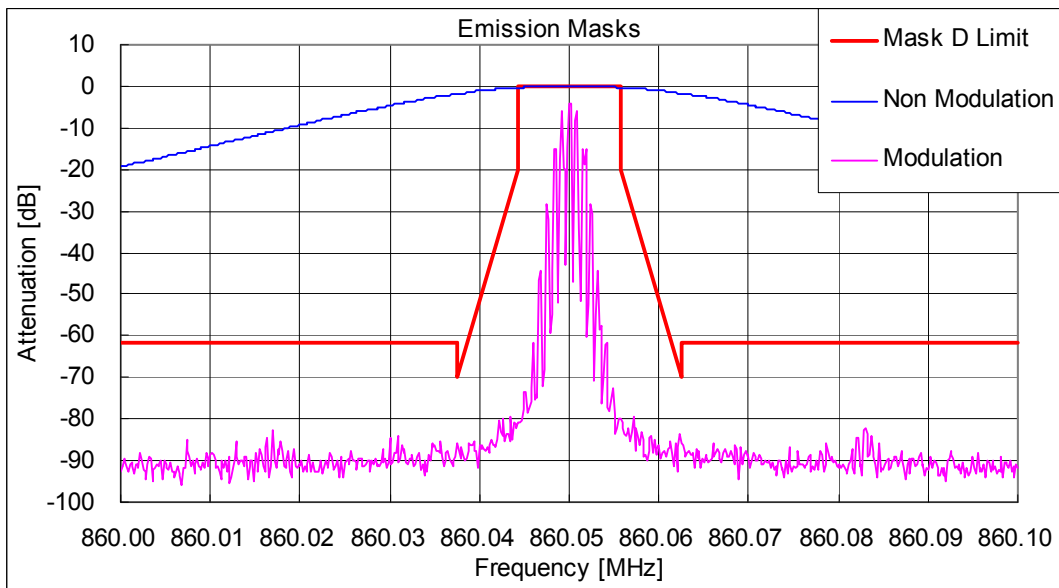

State : Low Power / Authorized Bandwidth 20 kHz/ 16K0F3E/ 806.05 MHz (FCC/RSS) (Band 1)
FCC Limit : Mask B, EA RSS Limit : Mask B

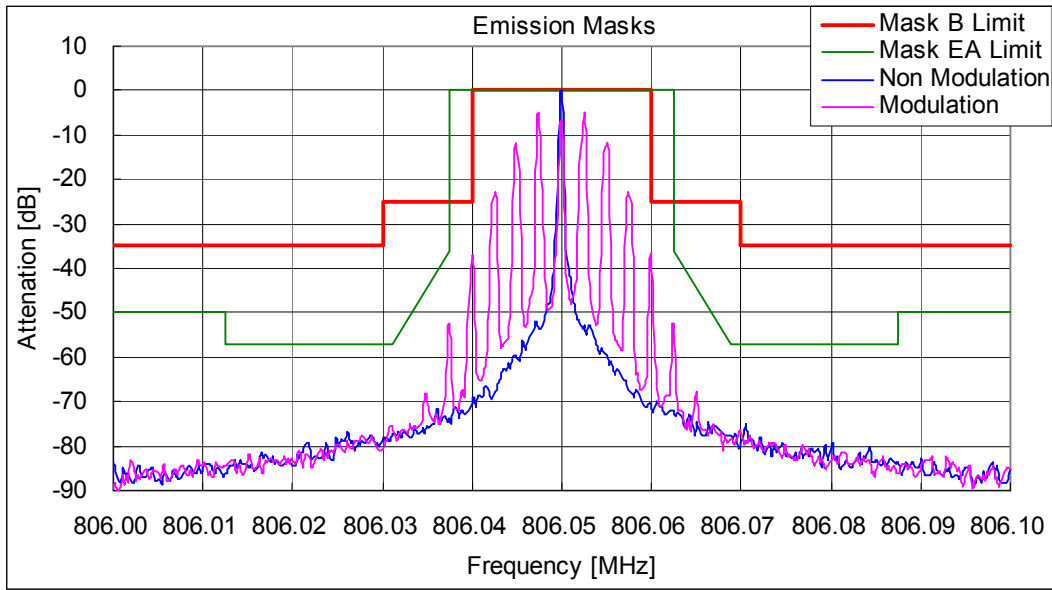

State : Low Power / Authorized Bandwidth 20 kHz/ 16K0F3E/ 860.05 MHz (FCC/RSS) (Band 2)
FCC Limit : Mask B, EA RSS Limit : Mask B

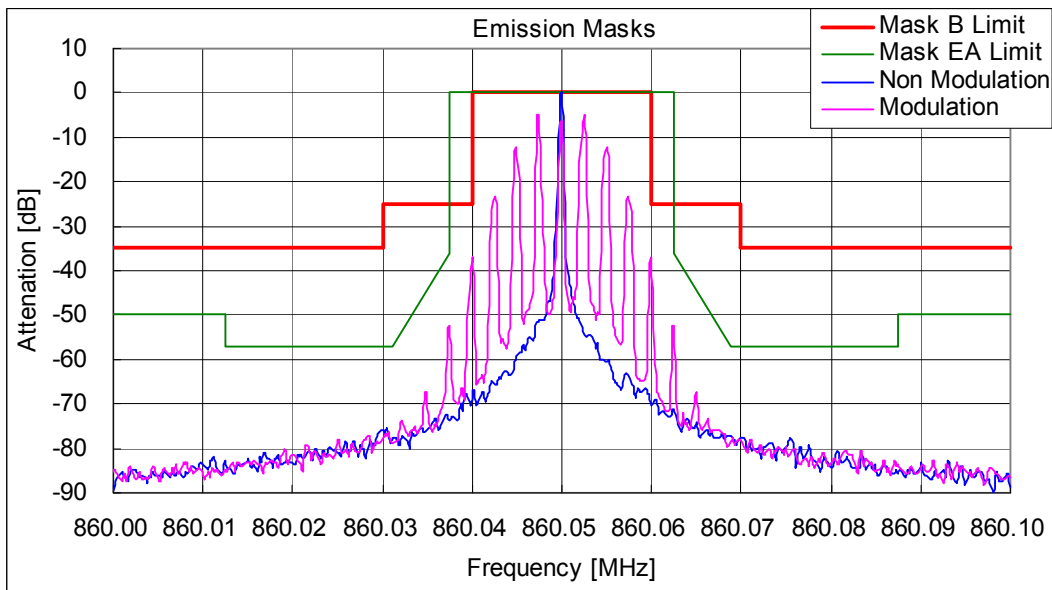

State : Low Power / Authorized Bandwidth 20 kHz/ 14K0F3E / 806.05 MHz(FCC/RSS) (Band 1)
FCC Limit : Mask B, EA RSS Limit : Mask B

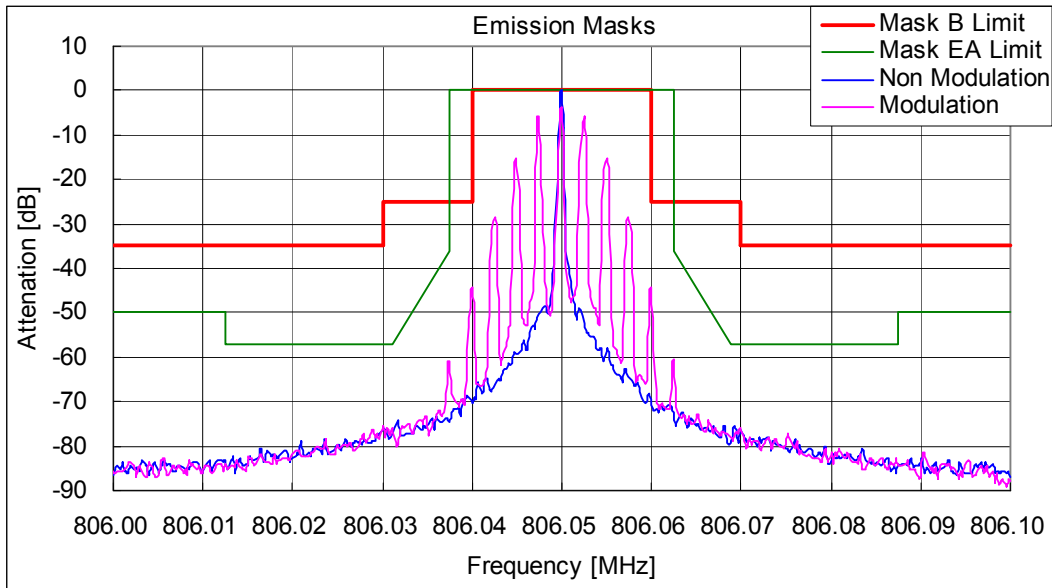

State : Low Power / Authorized Bandwidth 20 kHz/ 14K0F3E / 851.05 MHz(FCC/RSS) (Band 2)
FCC Limit : Mask B, EA RSS Limit : Mask B

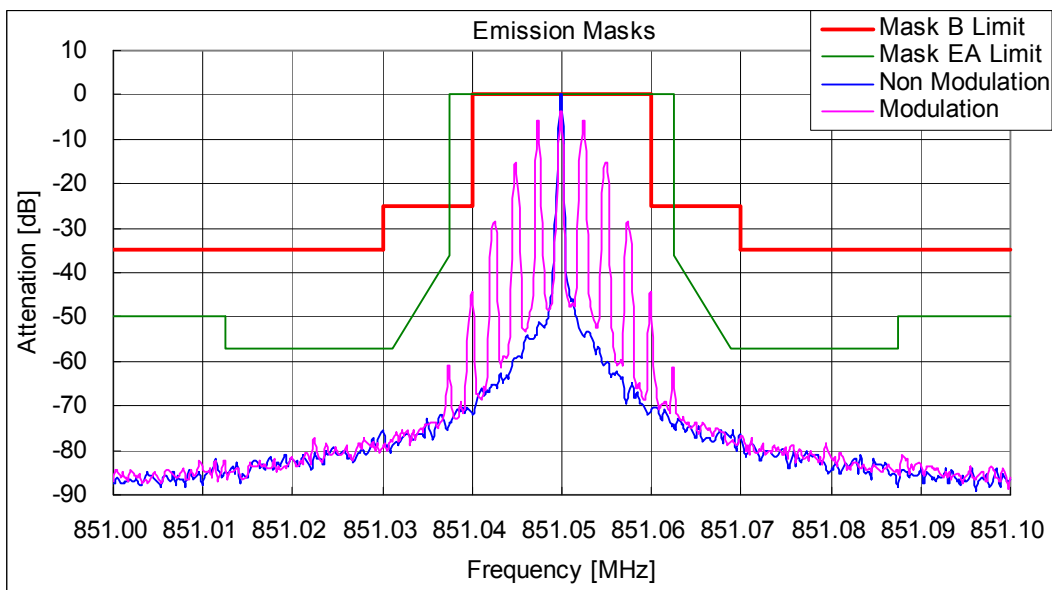

State : Low Power / Authorized Bandwidth 11.25 kHz/ 11K0F3E / 806.05 MHz (FCC) (Band 1)
FCC Limit : Mask B, EA

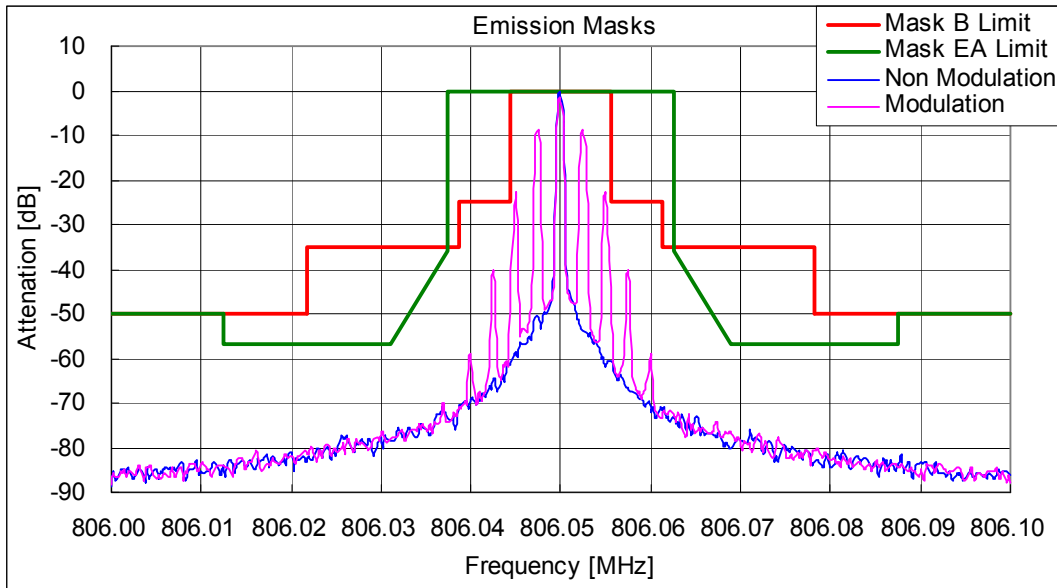

State : Low Power / Authorized Bandwidth 11.25 kHz/ 11K0F3E / 815.05 MHz (RSS) (Band 1)
RSS Limit : Mask D

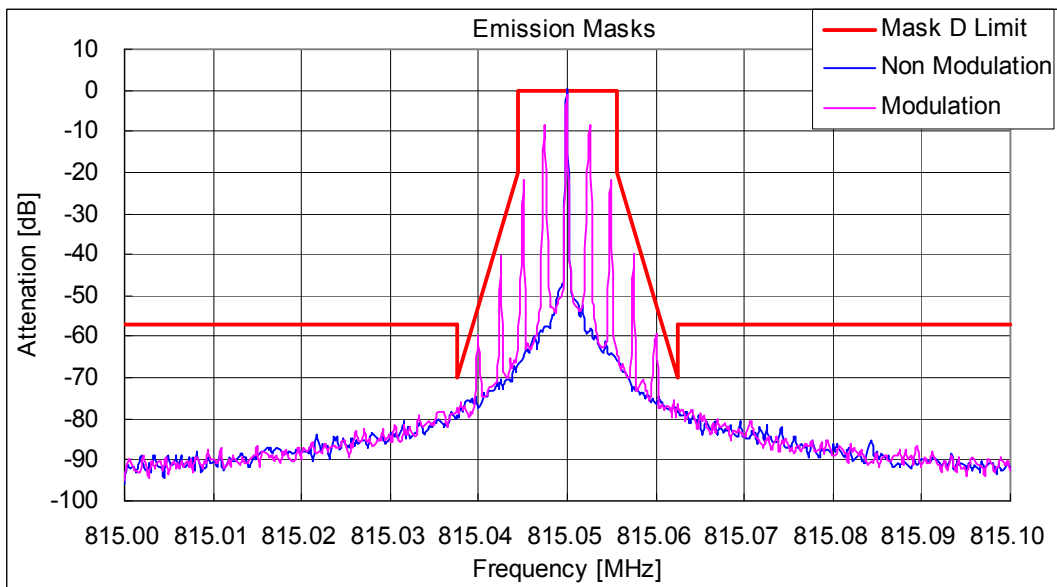

State : Low Power / Authorized Bandwidth 11.25 kHz/ 11K0F3E / 860.05 MHz (FCC) (Band 2)
FCC Limit : Mask B, EA

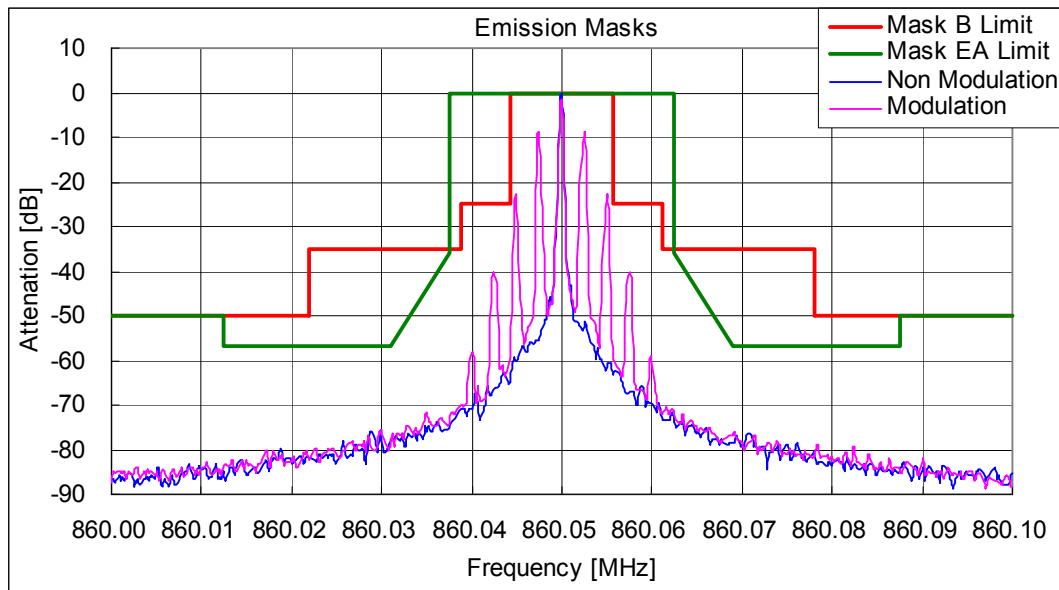

State : Low Power / Authorized Bandwidth 11.25 kHz/ 11K0F3E / 868.95 MHz (RSS) (Band 2)
RSS Limit : Mask D

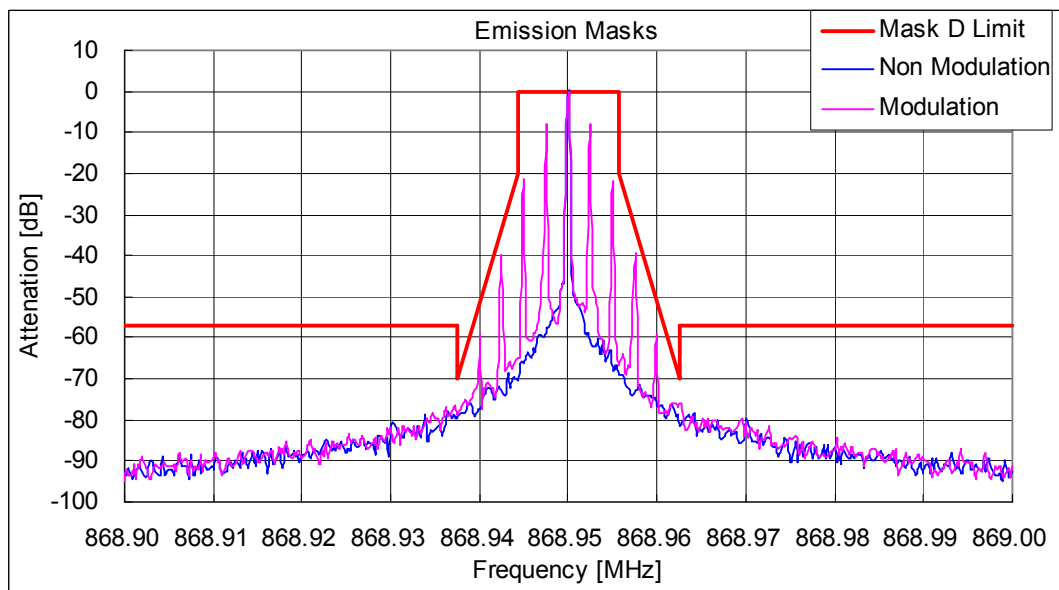

State : Low Power / Authorized Bandwidth 11.25 kHz/ 8K30F1E/ F1D/ F7W/ 815.05 MHz (FCC) (Band 1)
FCC Limit : Mask H, G, EA

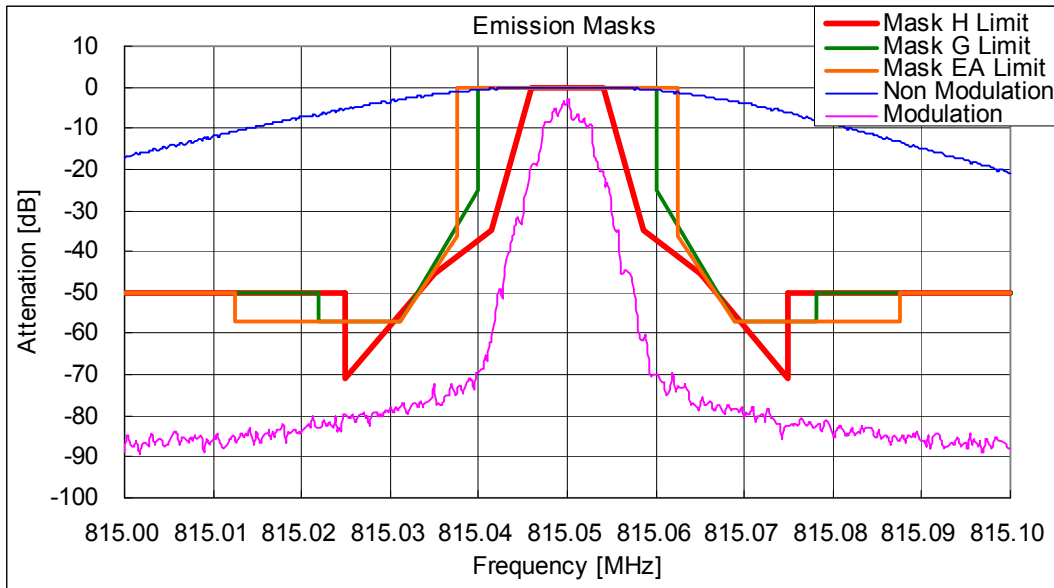

State : Low Power / Authorized Bandwidth 11.25 kHz/ 8K30F1E/ F1D/ F7W/ 815.05 MHz (RSS) (Band 1)
RSS Limit : Mask D

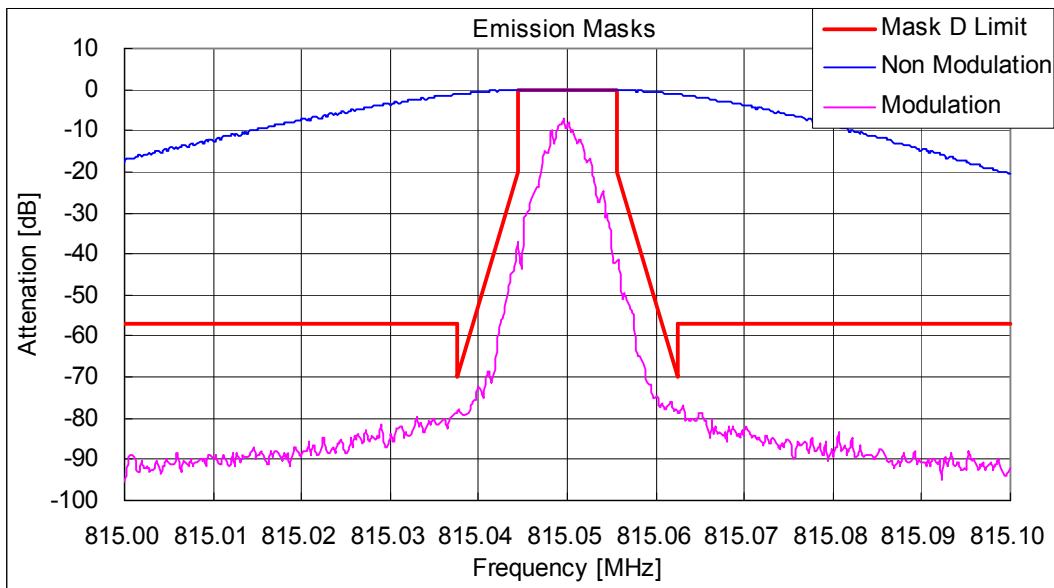

State : Low Power / Authorized Bandwidth 11.25 kHz/ 8K30F1E/ F1D/ F7W/ 868.95 MHz (FCC) (Band 2)
FCC Limit : Mask H, G, EA

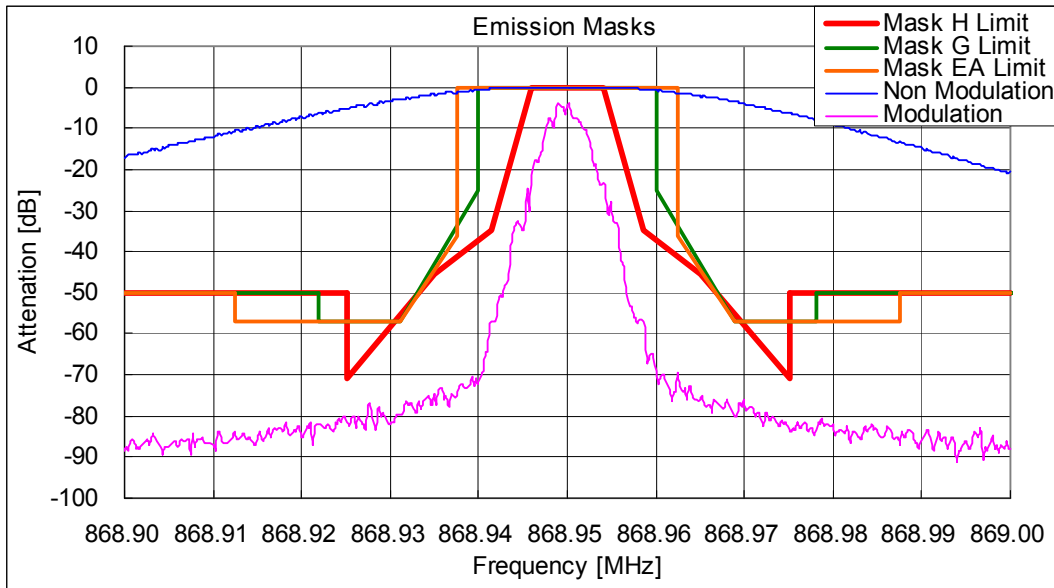

State : Low Power / Authorized Bandwidth 11.25 kHz/ 8K30F1E/ F1D/ F7W/ 860.05 MHz (RSS) (Band 2)
RSS Limit : Mask D

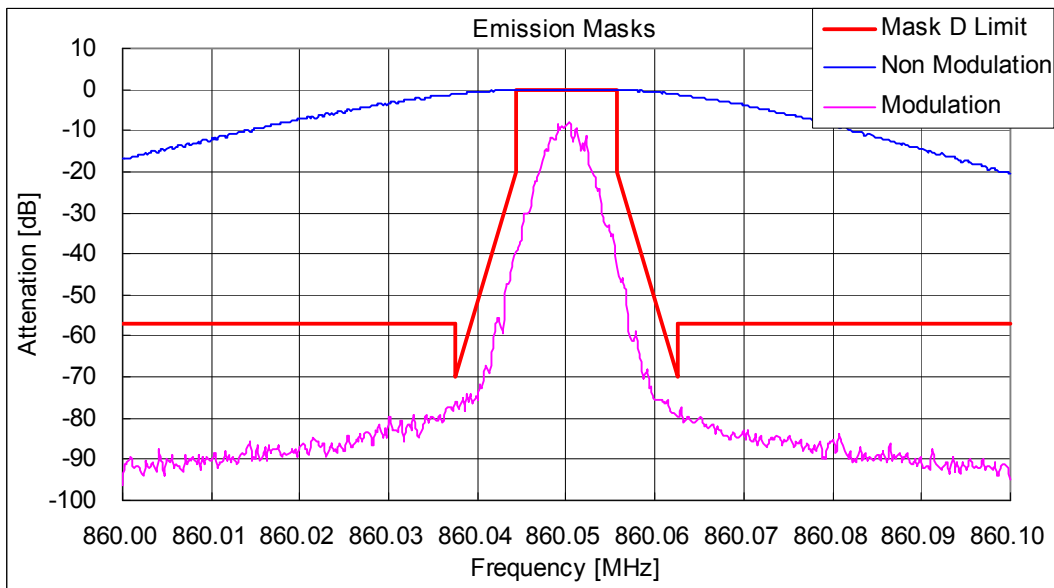

State : Low Power / Authorized Bandwidth 6 kHz/ 4K00F1E/ F1D/ F7W/ 815.05 MHz (FCC) (Band 1)
FCC Limit : Mask H, G, EA

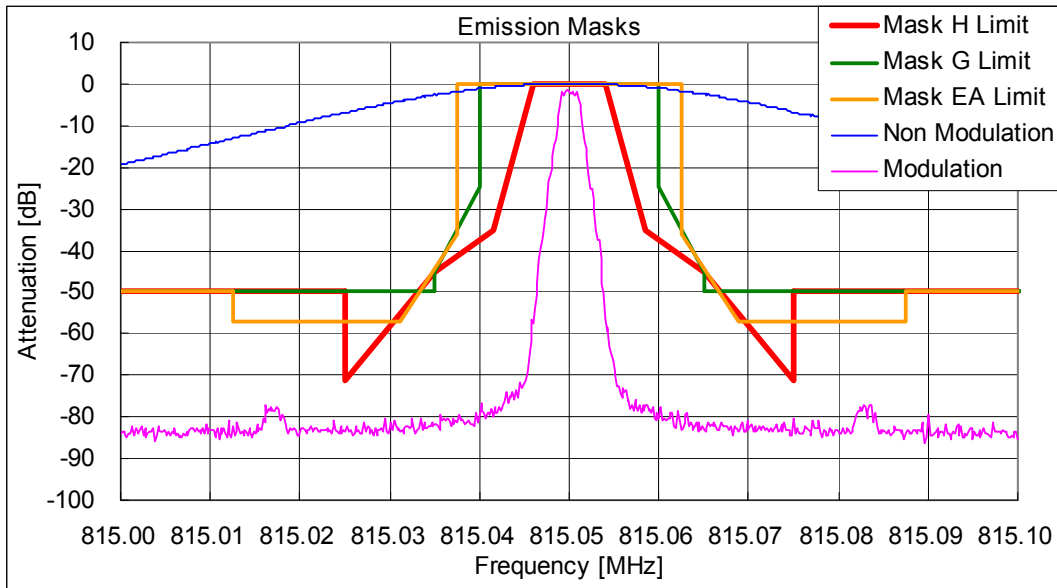

State : Low Power / Authorized Bandwidth 6 kHz/ 4K00F1E/ F1D/ F7W/ 806.05 MHz (RSS) (Band 1)
RSS Limit : Mask D

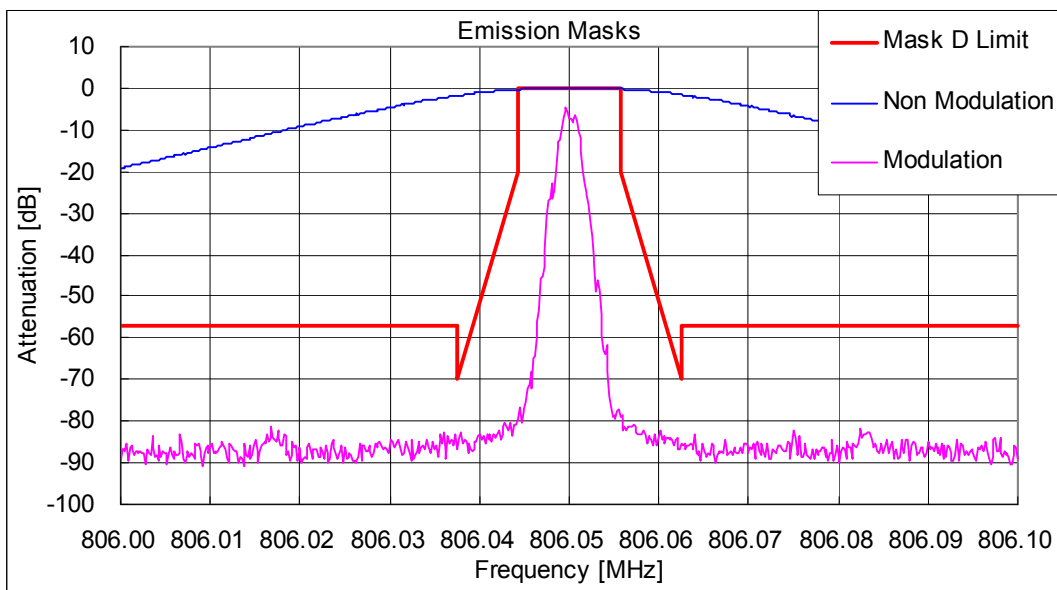

State : Low Power / Authorized Bandwidth 6 kHz/ 4K00F1E/ F1D/ F7W/ 851.05 MHz (FCC) (Band 2)
FCC Limit : Mask H, G, EA

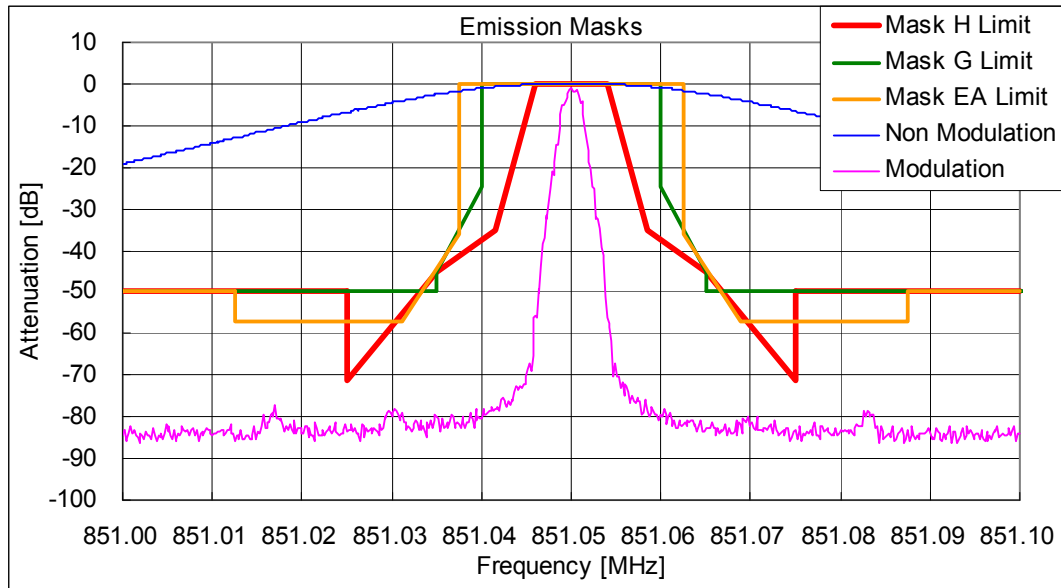

State : Low Power / Authorized Bandwidth 6 kHz/ 4K00F1E/ F1D/ F7W/ 868.95 MHz (RSS) (Band 2)
RSS Limit : Mask D

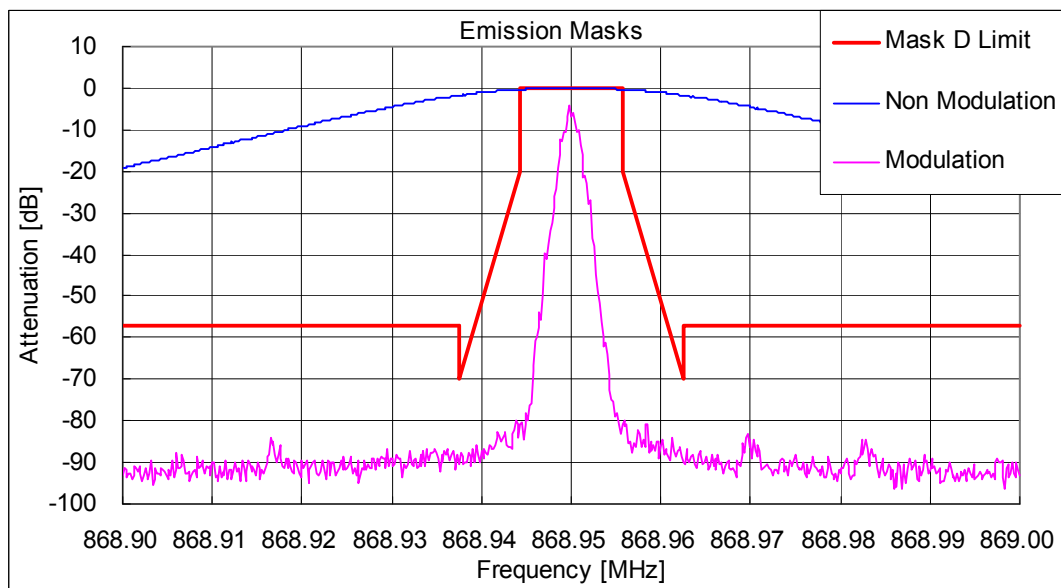

State : Low Power / Authorized Bandwidth 6 kHz/ 4K00F2D/ 815.05 MHz (FCC) (Band 1)
FCC Limit : Mask H, G, EA

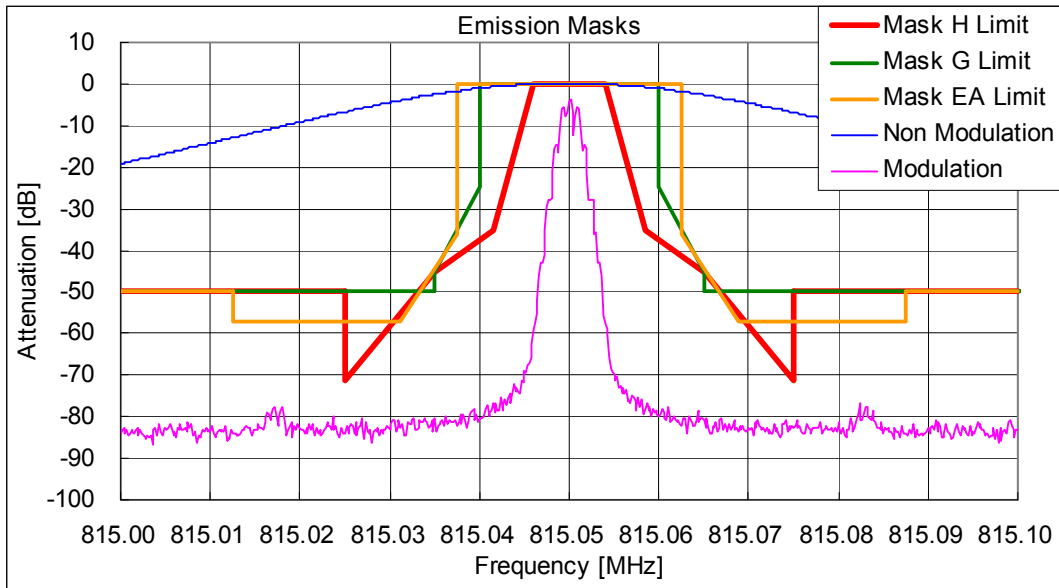

State : Low Power / Authorized Bandwidth 6 kHz/ 4K00F2D/ 815.05 MHz (RSS) (Band 1)
RSS Limit : Mask D

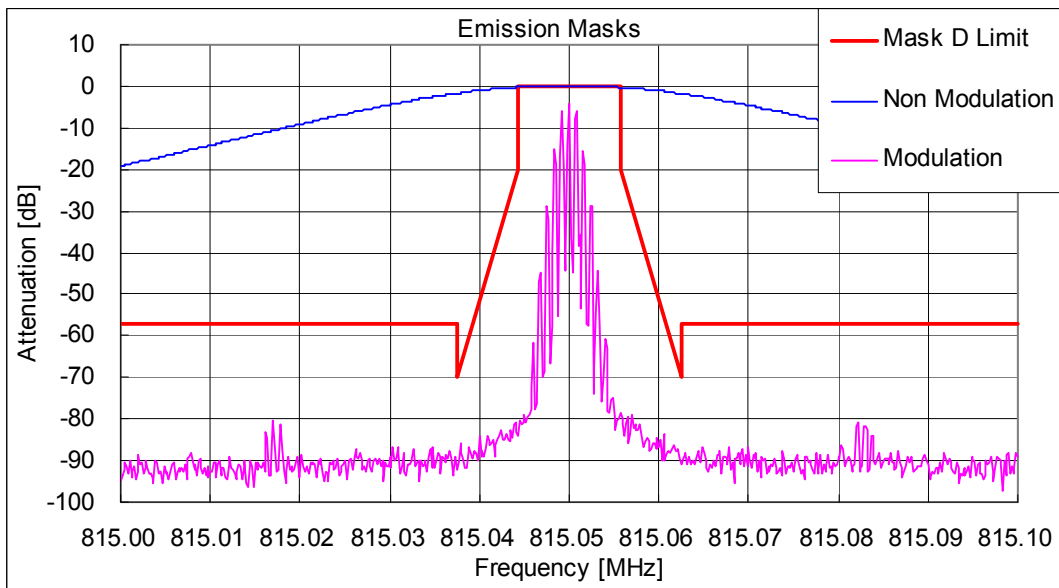

State : Low Power / Authorized Bandwidth 6 kHz/ 4K00F2D/ 860.05 MHz (FCC) (Band 2)
FCC Limit : Mask H, G, EA

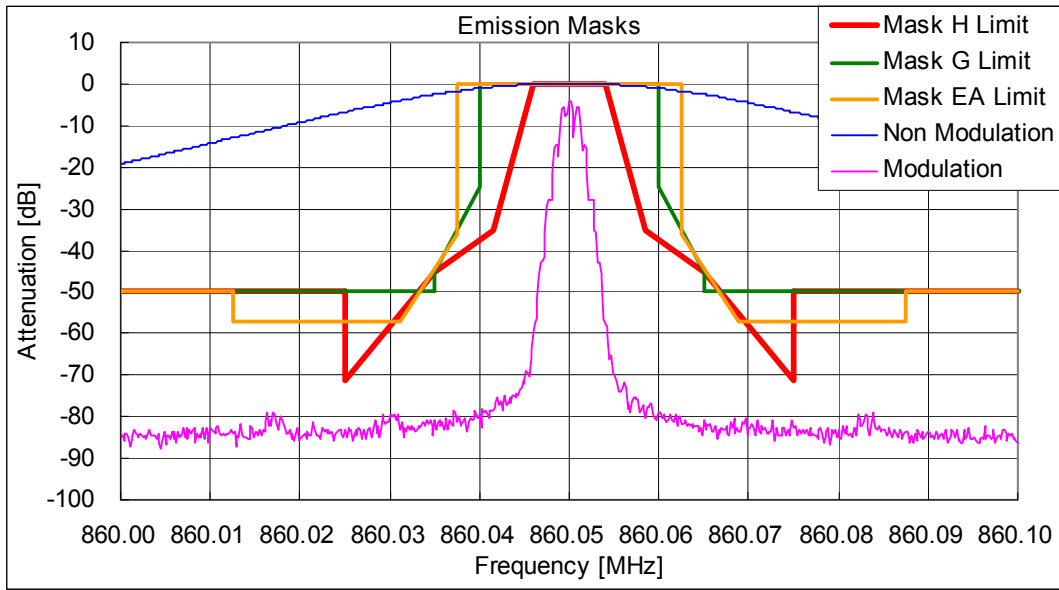

State : Low Power / Authorized Bandwidth 6 kHz/ 4K00F2D/ 851.05 MHz (RSS) (Band 2)
RSS Limit : Mask D

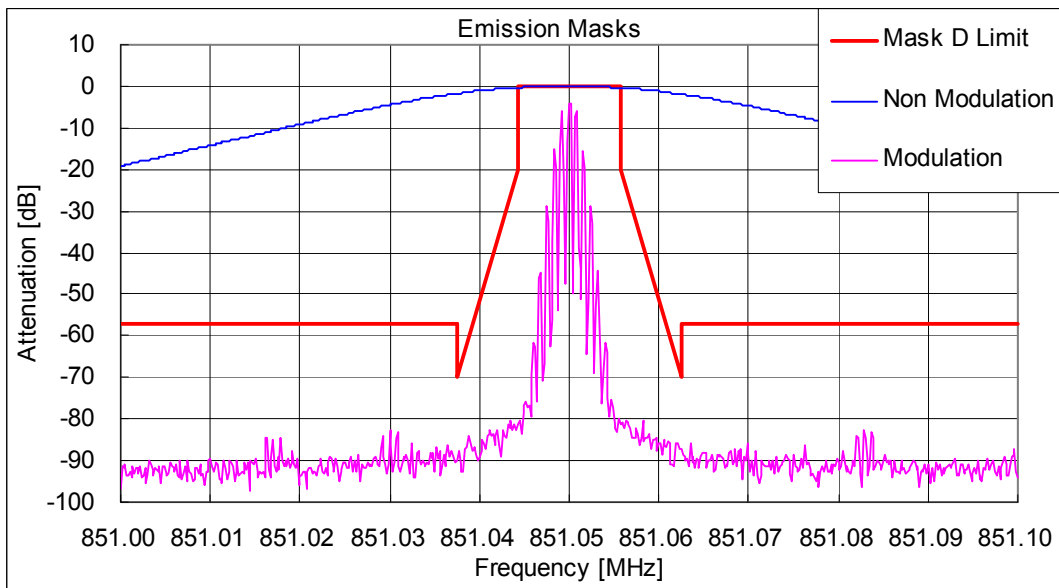

10.5 Transient Frequency Behavior

REGULATIONS : FCC Part 90 Section 214 / RSS-119 Section 5.9

TEST METHOD/GUIDE : ANSI/TIA-603-D, Section 2.2.19.3

Test Procedure

- 1 The EUT and test equipment were set up as shown on the following page.
- 2 The transmitter was turned on.
- 3 The transmitter carrier level was measured at the output of the combiner .
- 4 The transmitter was turned off.
- 5 An RF signal generator (1) modulated with a 1 kHz tone at either 25 kHz or 12.5 kHz or 6.25 kHz deviation, and set to the same frequency as the assigned transmitter frequency, (2) was adjusted to a level -30 dB below the level recorded in Procedure 3, as measured at the output of the combiner.
 This level was then fixed for the remainder of the test and is recorded at step h.
- 6 The oscilloscope was setup using TIA-603 steps j and k as a guide, however 1000 Hz tone was adjusted at +- 2.5 /div vertically centered on the display.
- 7 The transmitter was turned on, and the level of the carrier at the output of the combiner was recorded as step l.
- 8 The carrier on-time as referenced in TIA-603 steps m, n, and o was captured and plotted.
- 9 The carrier off-time as referenced in TIA-603 steps p, q, r, and s was captured and plotted.

No.	Equipment	Manufacture	Model No.	Serial No.	Cal Date	Cal Exp.
1	Attenuator (10dB)	Aeroflex/Wenshel	66-10-34	BY2887	May 09, 12	May 31, 13
2	Attenuator (30dB)	Weinschel	WA-29-30-34	8923	May 09, 12	May 31, 13
3	Attenuator (3dB)	TME	CFA-20NPJ-3	679701	Dec. 20, 12	Dec. 31, 13
4	Attenuator(6dB)	HUBER+SUHNER	6806.17B	KSR0188	Dec. 20, 12	Dec. 31, 13
5	Step Attenuator	Hewlett Packard	8494B	2726A14515	Dec. 20, 12	Dec. 31, 13
6	Power Meter	Hewlett Packard	E4418B	GB38410265	May 10, 12	May 31, 13
7	Power Sensor	Hewlett Packard	8482A	US37292237	May 10, 12	May 31, 13
8	Oscilloscope	Tektronix	TDS 680B	B010292	Jan. 18, 13	Jan. 31, 14
9	Modulation Analyzer	Hewlett Packard	8901B	3403A04852	Aug. 09, 12	Aug. 31, 13
10	Combiner(1)	Anritsu	Z-164A	M89249	Dec. 21, 12	Dec. 31, 13
11	Combiner(2)	Anritsu	Z-164A	M89549	Dec. 21, 12	Dec. 31, 13
12	Signal Generator	Rohde&Schwarz	SMB 100A	105709	Jan. 11, 13	Jan. 31, 14
13	Digital Multi Meter	FLUKE	8846A	9642018	May 11, 12	May 31, 13
14	DC Power Supply	Daiichi denpa kogyo	GZV4000	90290931	None	None

Measuring Cables

No.	Cable	Manufacture	Model No.	Serial No.	Cal Date	Cal Exp.
W1	Coaxial Cable	Suhner	SUCOFLEX104	KSR00217	Dec. 20, 12	Dec. 31, 13
W10	Coaxial Cable	Pacific custom	RG-58 C/U	KSR00094	Dec. 21, 12	Dec. 31, 13
W12	Coaxial Cable	Suhner	SUCOFLEX104	KSR00042	May 09, 12	May 31, 13
W4	Coaxial Cable	Pacific custom	RG-58 C/U	KSR00097	Dec. 21, 12	Dec. 31, 13
W5	Coaxial Cable	Suhner	SUCOFLEX104	KSR00091	May 09, 12	May 31, 13
W9	Coaxial Cable	Pacific custom	RG-58 C/U	KSR00041	May 09, 12	May 31, 13

Measuring Equipment Configuration

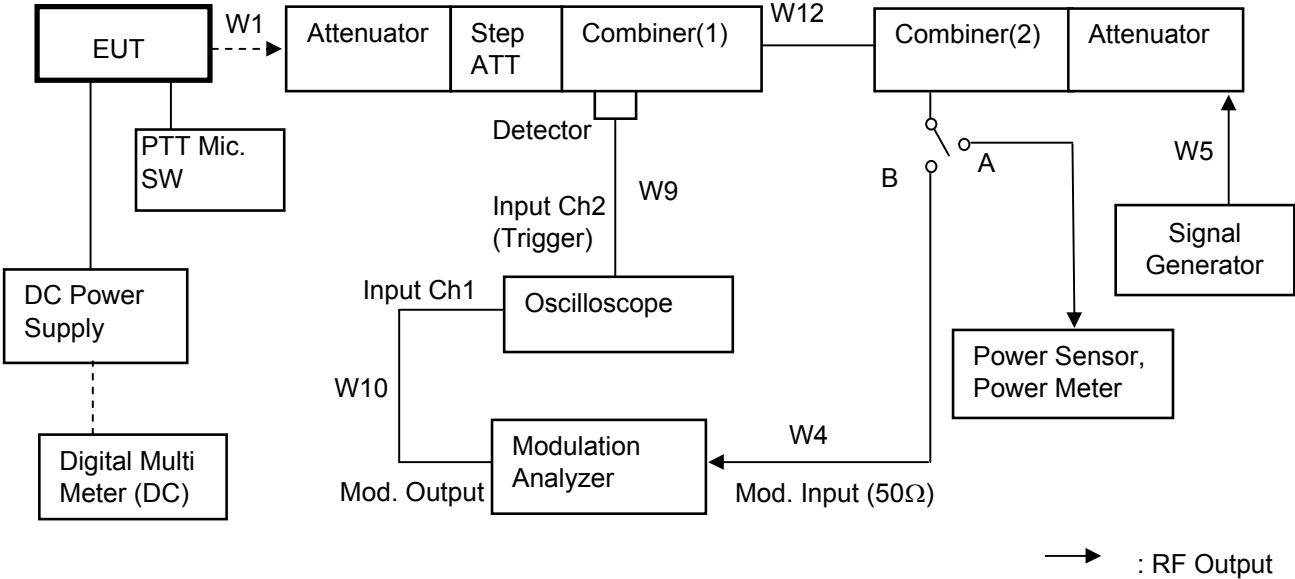

Test Results

Test date	May 13, 2013	
Location	Kashima No.1 Test Site	
temperature	24.1	[degree C]
Humidity Variation	65	[%]
Atmospheric Pressure	101.2	[kPa]
Test Engineer	Koichi Wagatsuma	

Test was carried out for all the frequency band of section 10.1
 State the worst case (below).

State : High Power / Authorized Bandwidth 20 kHz / 16K0F3E / 823.95 MHz (FCC/RSS) (Band 1)/ PTT:OFF -ON

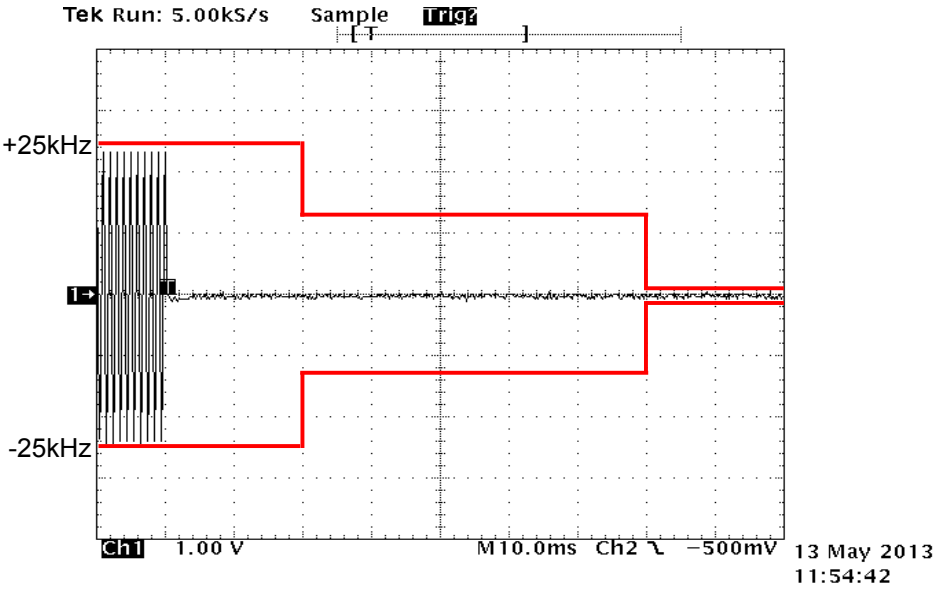

State : High Power / Authorized Bandwidth 20 kHz / 16K0F3E / 823.95 MHz (FCC/RSS) (Band 1)/ PTT:ON -OFF

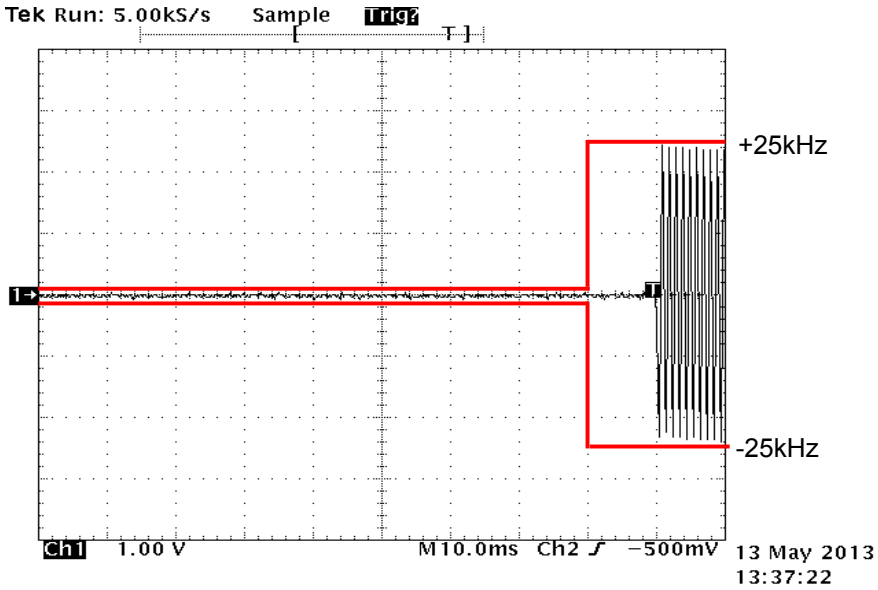

State : High Power / Authorized Bandwidth 20 kHz / 16K0F3E / 860.05 MHz (FCC/RSS) (Band 2)/ PTT:OFF -ON

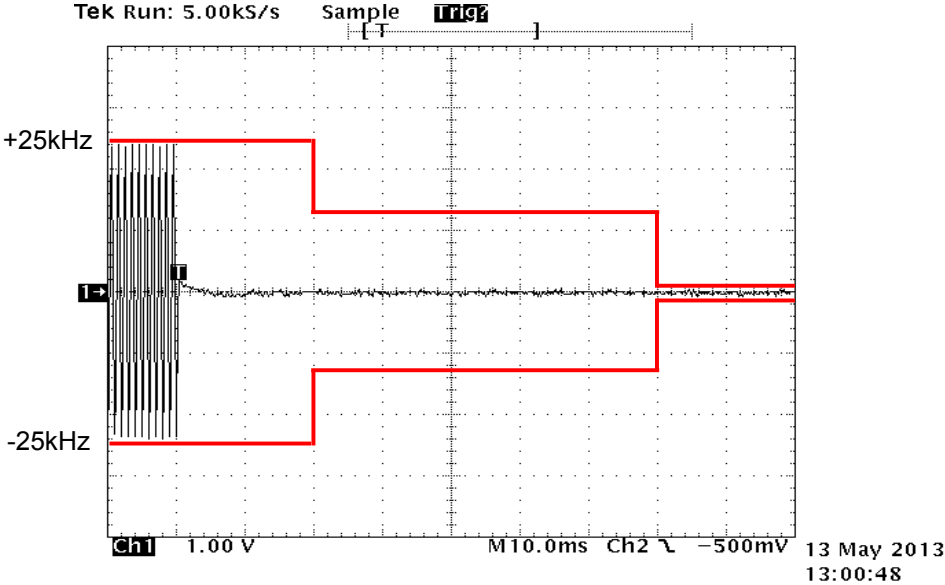

State : High Power / Authorized Bandwidth 20 kHz / 16K0F3E / 860.05 MHz (FCC/RSS) (Band 2)/ PTT:ON -OFF

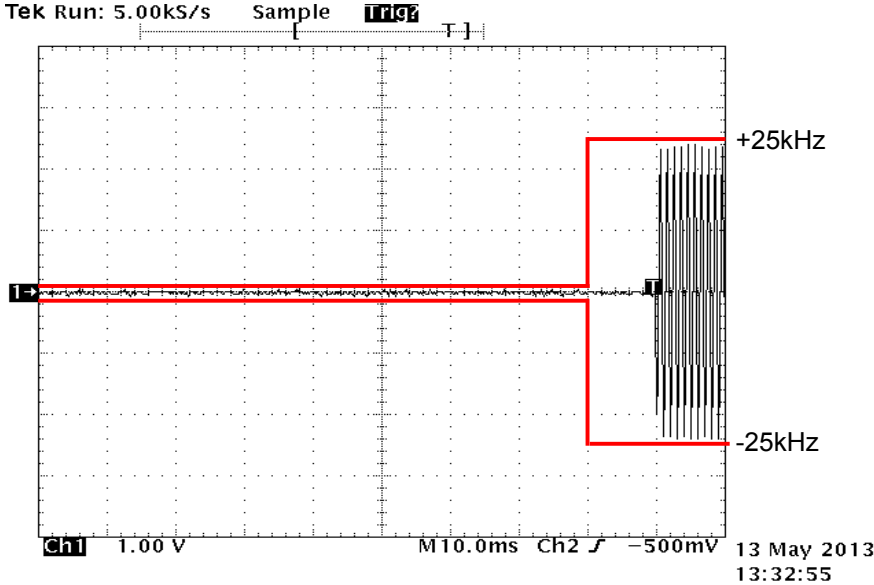

State : High Power / Authorized Bandwidth 20 kHz / 14K0F3E / 806.05 MHz (FCC/RSS) (Band 1)/ PTT:OFF -ON

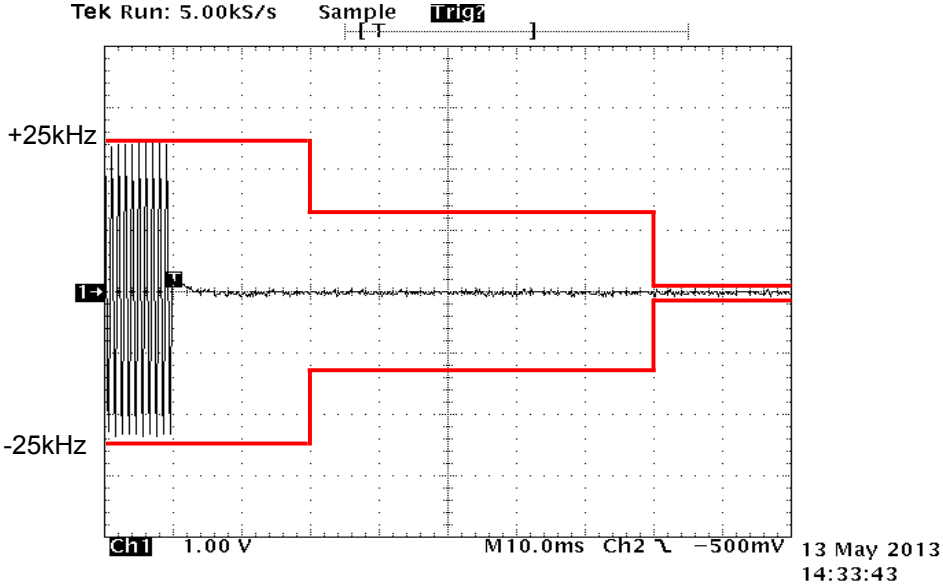

State : High Power / Authorized Bandwidth 20 kHz / 14K0F3E / 806.05 MHz (FCC/RSS) (Band 1)/ PTT:ON -OFF

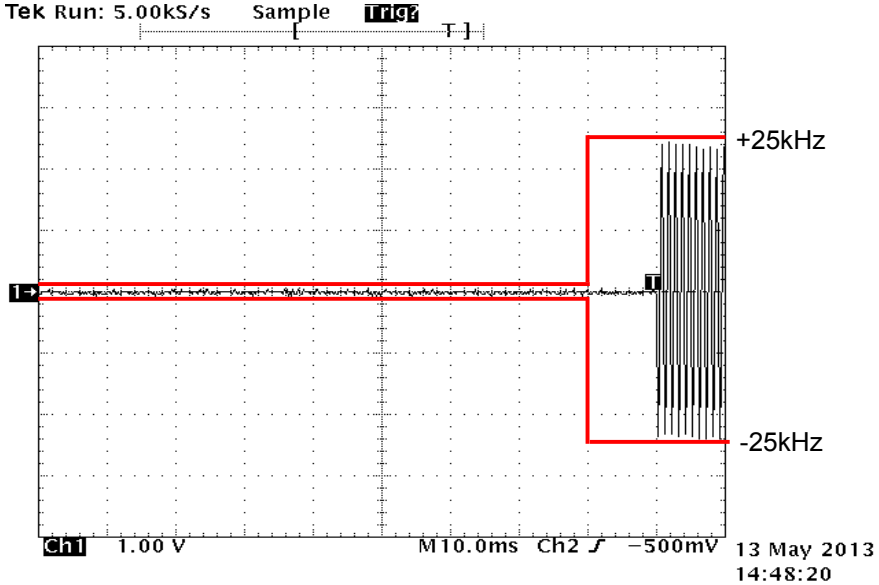

State : High Power / Authorized Bandwidth 20 kHz / 14K0F3E / 868.95 MHz (FCC/RSS) (Band 2)/ PTT:OFF -ON

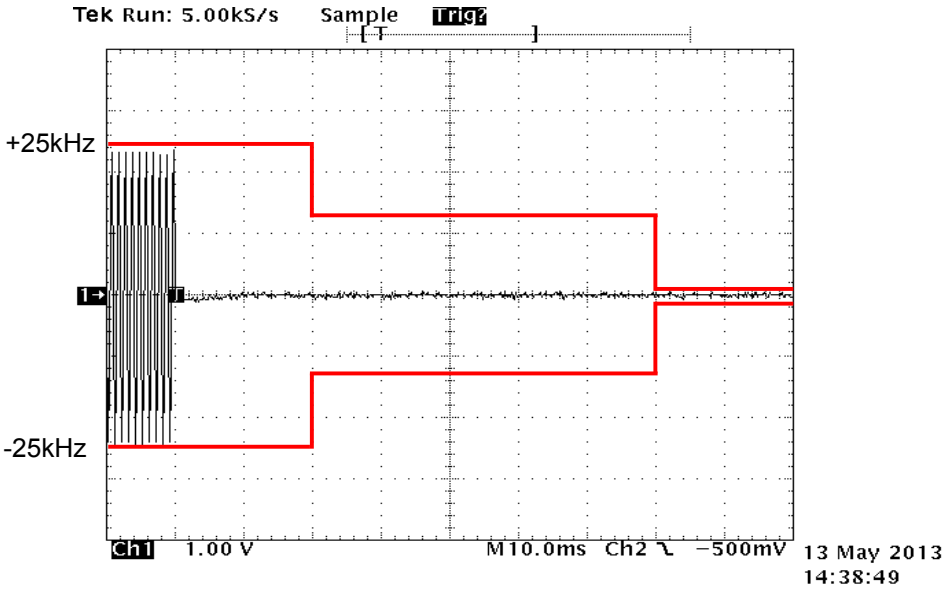

State : High Power / Authorized Bandwidth 20 kHz / 14K0F3E / 868.95 MHz (FCC/RSS) (Band 2)/ PTT:ON - OFF

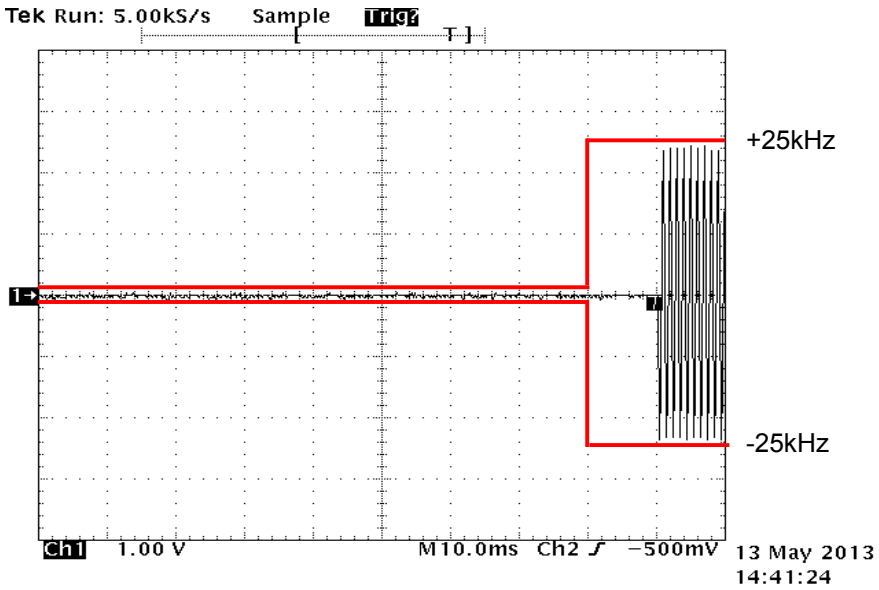

State : High Power / Authorized Bandwidth 11.25 kHz / 11K0F3E / 815.05 MHz (FCC/RSS) (Band 1)/ PTT:OFF -ON

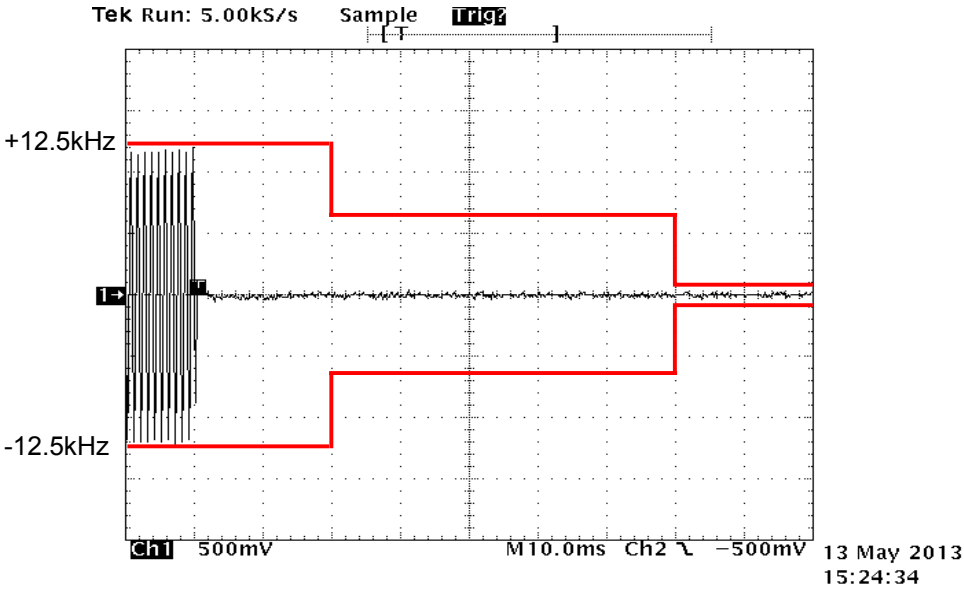

State : High Power / Authorized Bandwidth 11.25 kHz / 11K0F3E / 815.05 MHz (FCC/RSS) (Band 1)/ PTT:ON - OFF

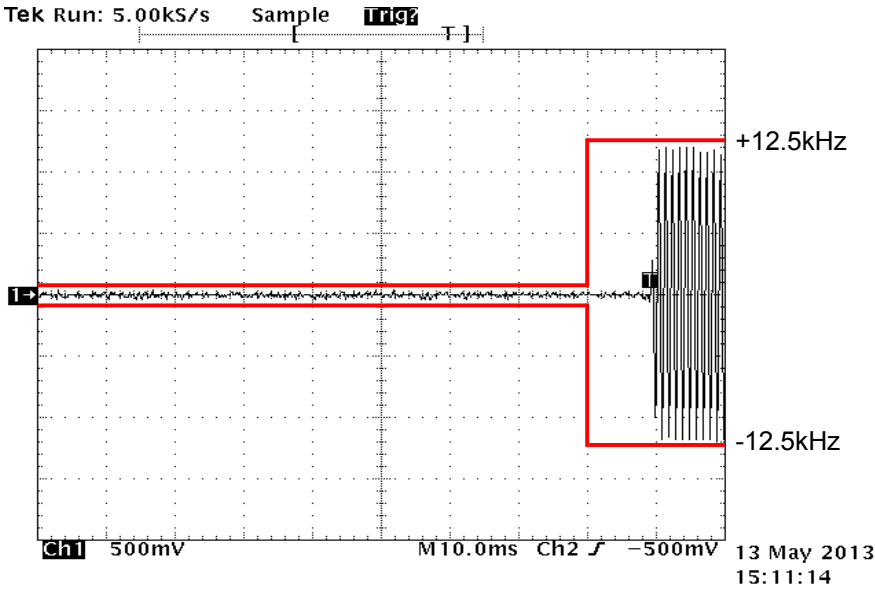

State : High Power / Authorized Bandwidth 11.25 kHz / 11K0F3E / 851.05 MHz (FCC/RSS) (Band 2)/ PTT:OFF -ON

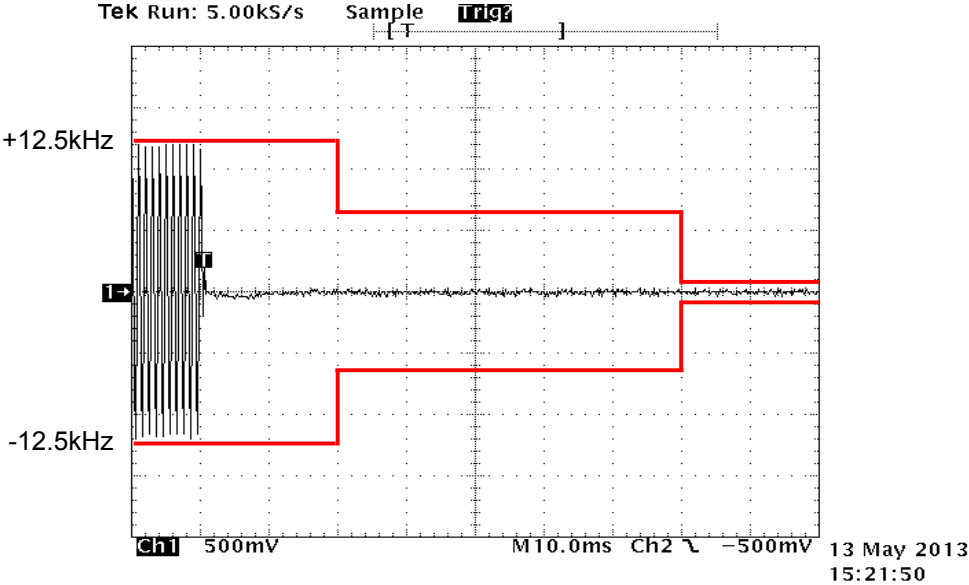

State : High Power / Authorized Bandwidth 11.25 kHz / 11K0F3E / 851.05 MHz (FCC/RSS) (Band 2)/ PTT:ON - OFF

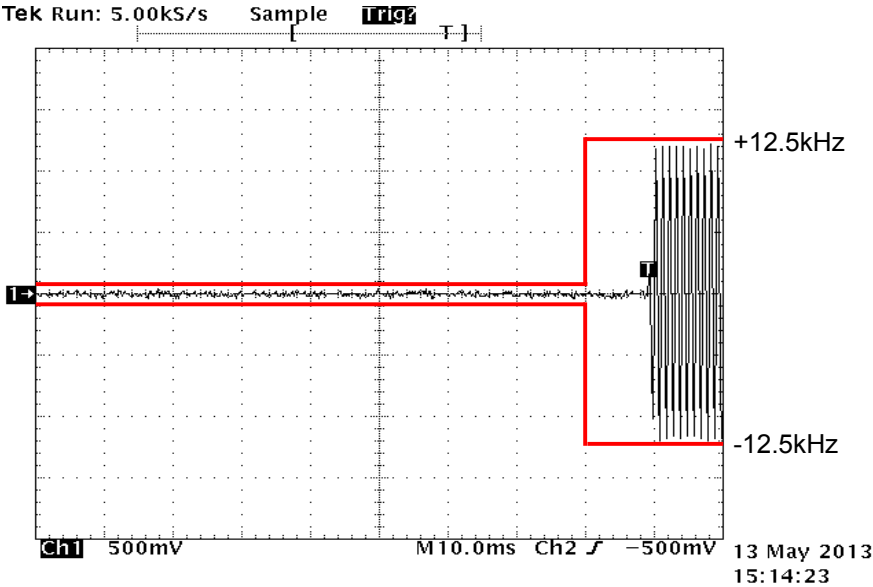

State : High Power / Authorized Bandwidth 11.25 kHz / 8K30F1E/F1D/F7W / 815.05 MHz (FCC/RSS) (Band 1)/ PTT:OFF -ON

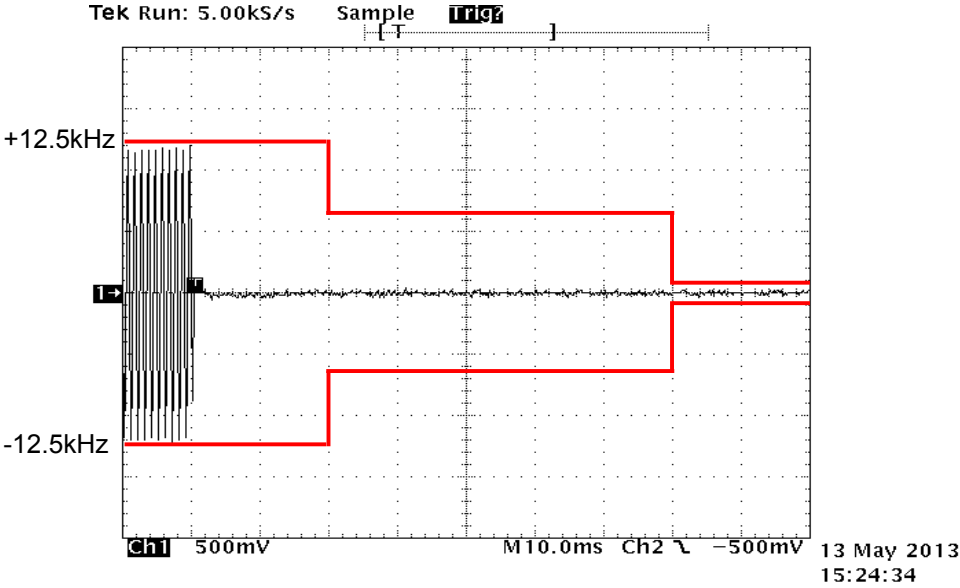

State : High Power / Authorized Bandwidth 11.25 kHz / 8K30F1E/F1D/F7W / 815.05 MHz (FCC/RSS) (Band 1)/ PTT:ON - OFF

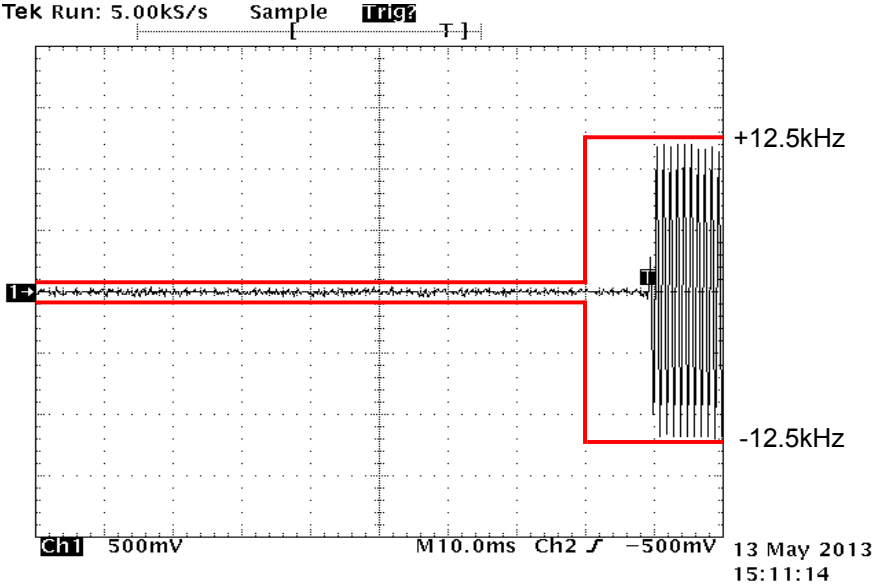

State : High Power / Authorized Bandwidth 11.25 kHz / 8K30F1E/F1D/F7W / 851.05 MHz (FCC/RSS) (Band 2)/ PTT:OFF -ON

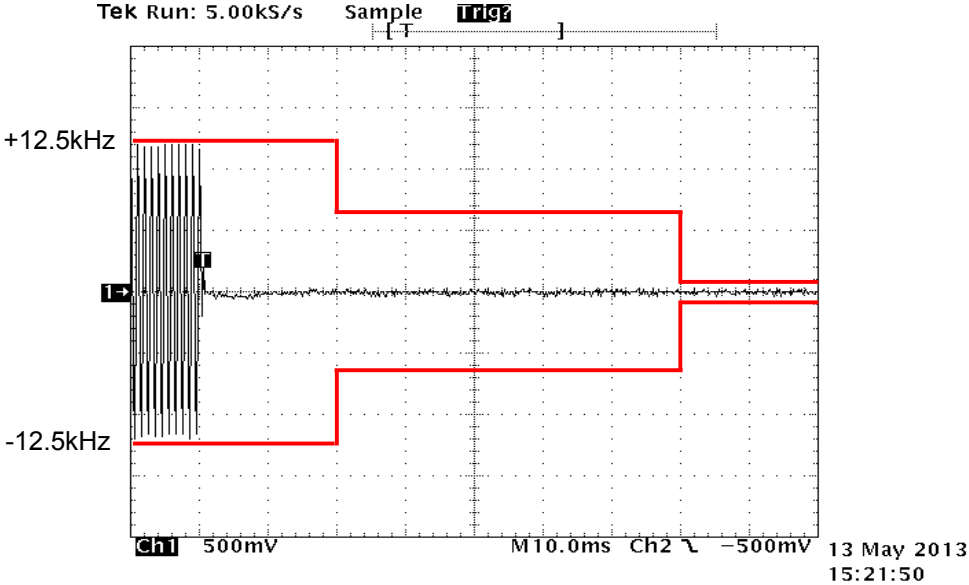

State : High Power / Authorized Bandwidth 11.25 kHz / 8K30F1E/F1D/F7W / 851.05 MHz (FCC/RSS) (Band 2)/ PTT:ON - OFF

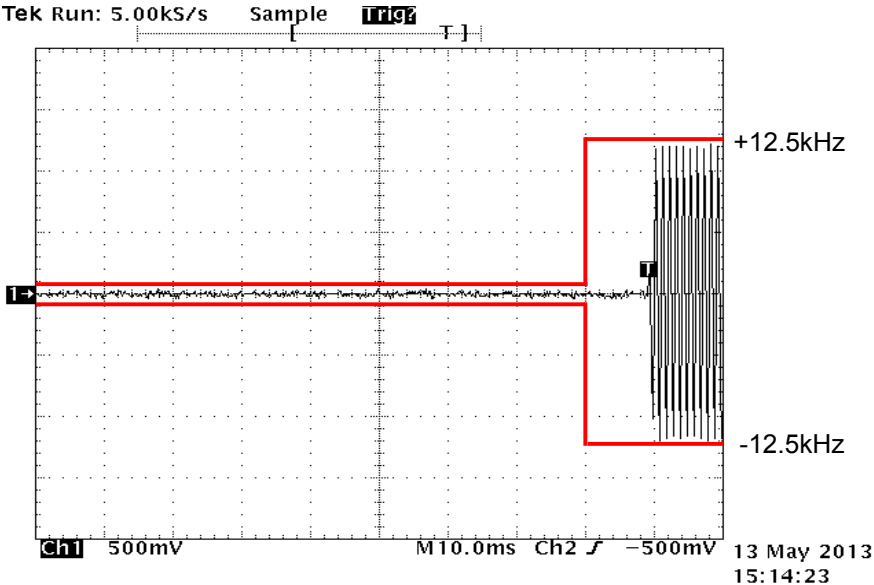

State : High Power / Authorized Bandwidth 6 kHz / 4K00F1E/F1D/F7W / 806.05 MHz (FCC/RSS) (Band 1)/ PTT:OFF -ON

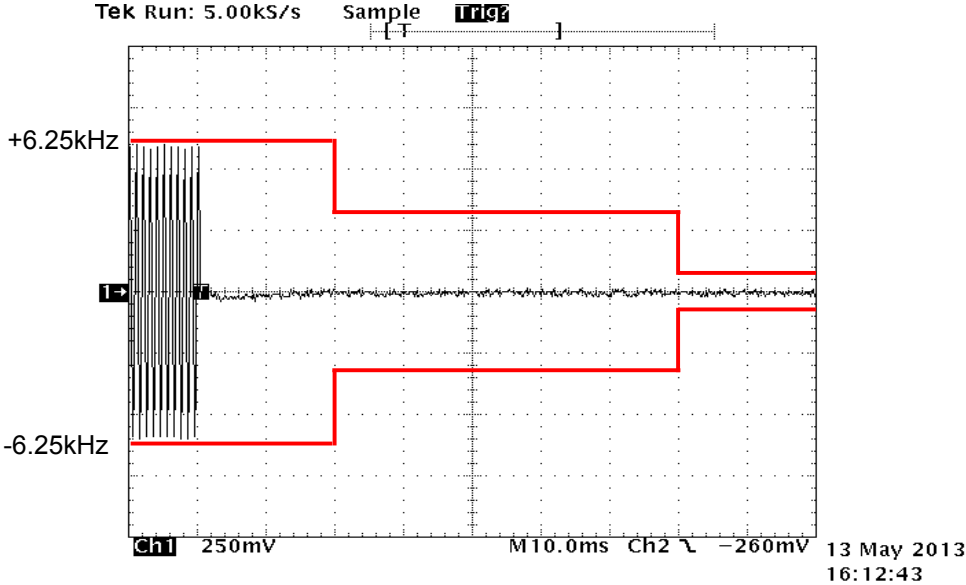

State : High Power / Authorized Bandwidth 6 kHz / 4K00F1E/F1D/F7W / 806.05 MHz (FCC/RSS) (Band 1)/ PTT:ON - OFF

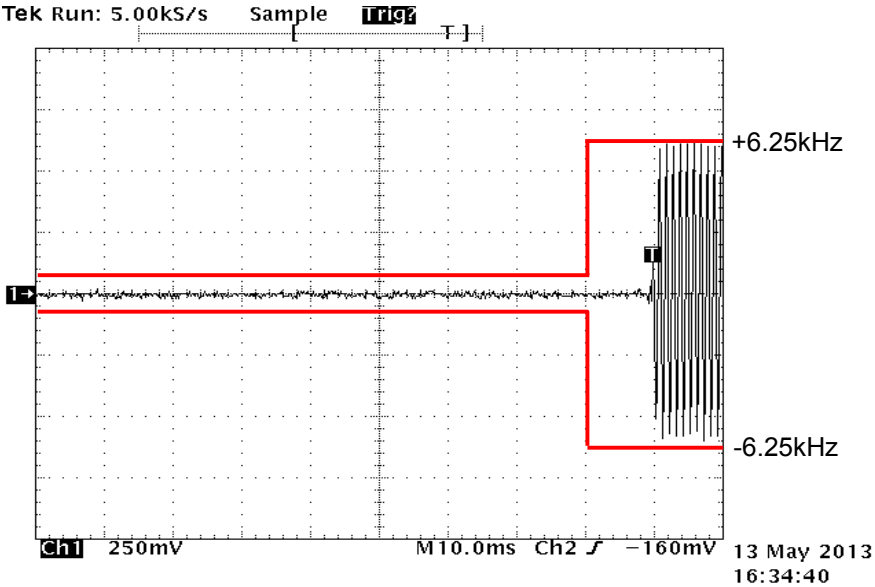

State : High Power / Authorized Bandwidth 6 kHz / 4K00F1E/F1D/F7W / 860.05 MHz (FCC/RSS) (Band 2)/ PTT:OFF -ON

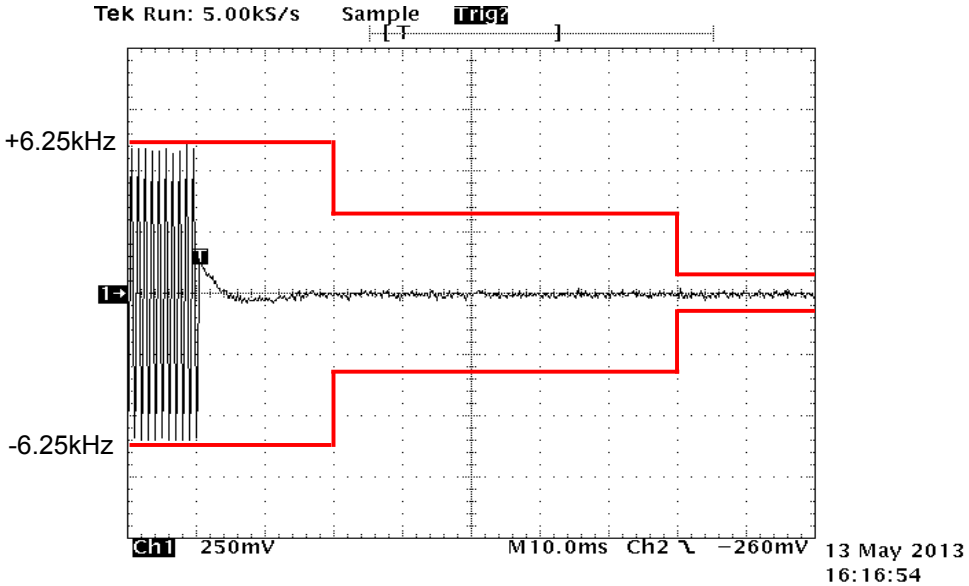

State : High Power / Authorized Bandwidth 6 kHz / 4K00F1E/F1D/F7W / 860.05 MHz (FCC/RSS) (Band 2)/ PTT:ON - OFF

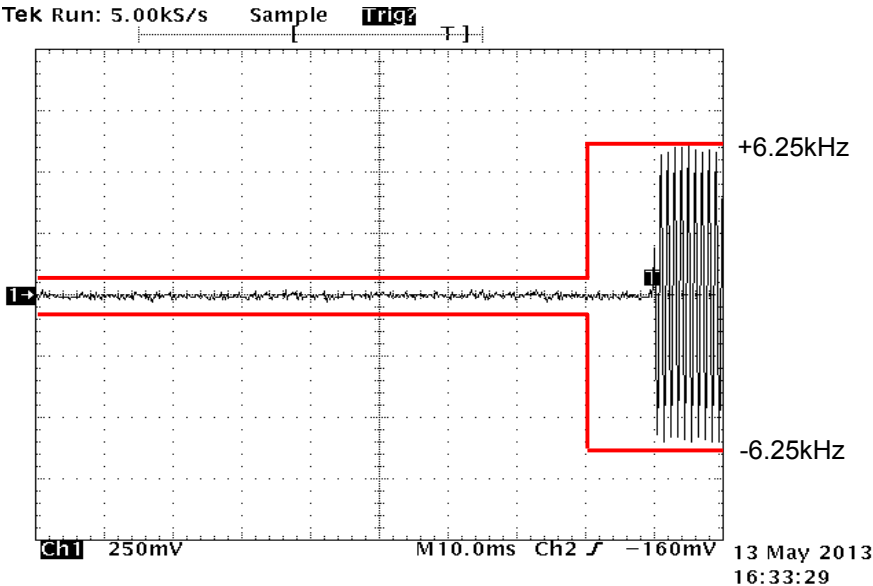

State : High Power / Authorized Bandwidth 6 kHz / 4K00F2D / 806.05 MHz (FCC/RSS) (Band 1)/ PTT:OFF -ON

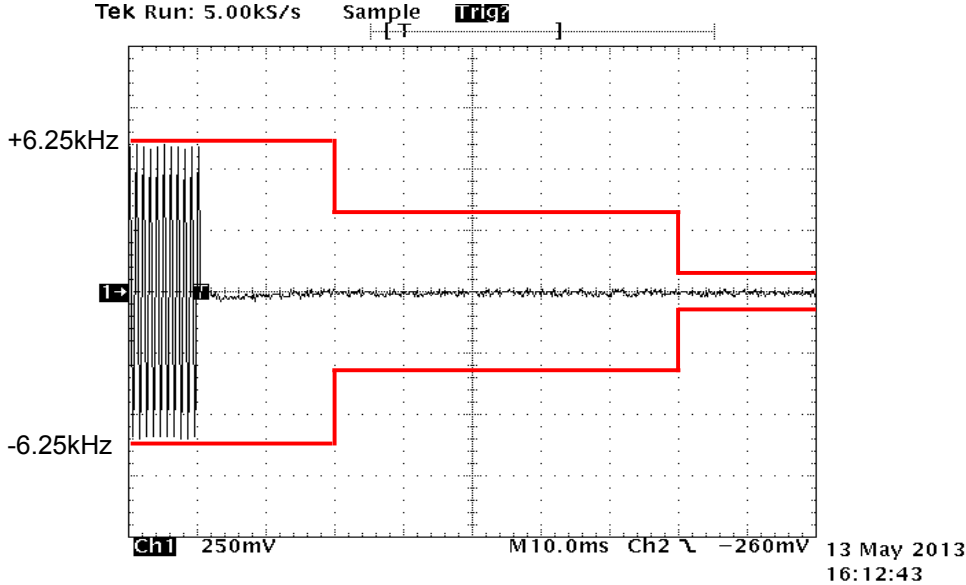

State : High Power / Authorized Bandwidth 6 kHz / 4K00F2D / 806.05 MHz (FCC/RSS) (Band 1)/ PTT:ON - OFF

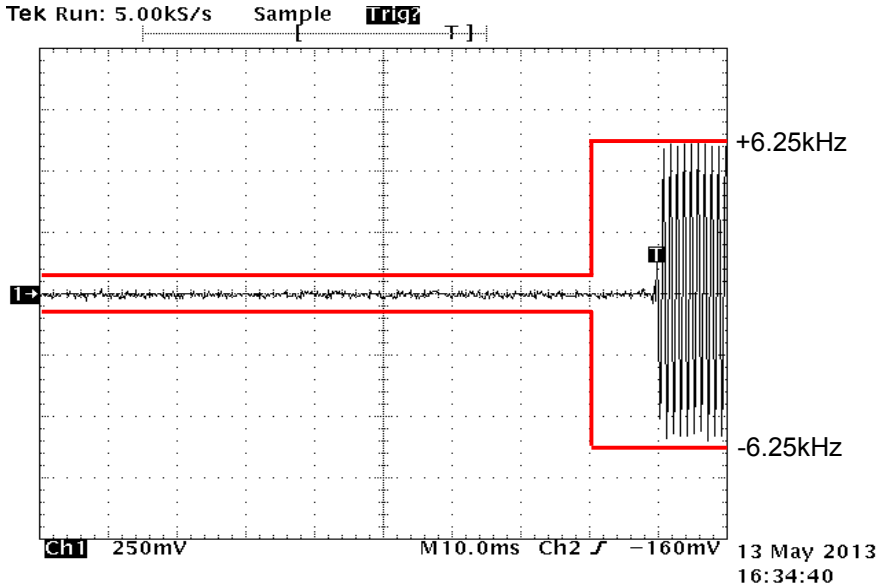

State : High Power / Authorized Bandwidth 6 kHz / 4K00F2D / 860.05 MHz (FCC/RSS) (Band 2)/ PTT:OFF -ON

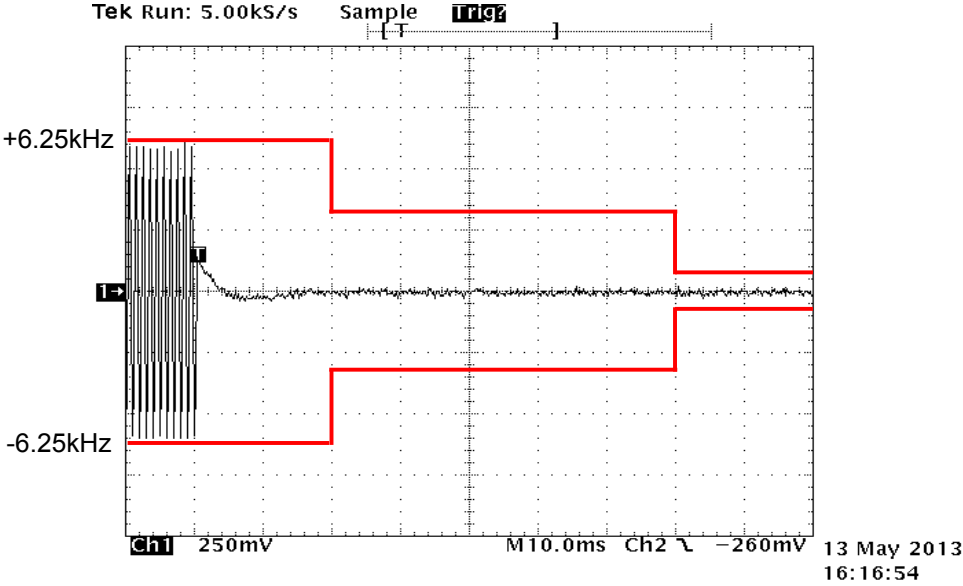

State : High Power / Authorized Bandwidth 6 kHz / 4K00F2D / 860.05 MHz (FCC/RSS) (Band 2)/ PTT:ON - OFF

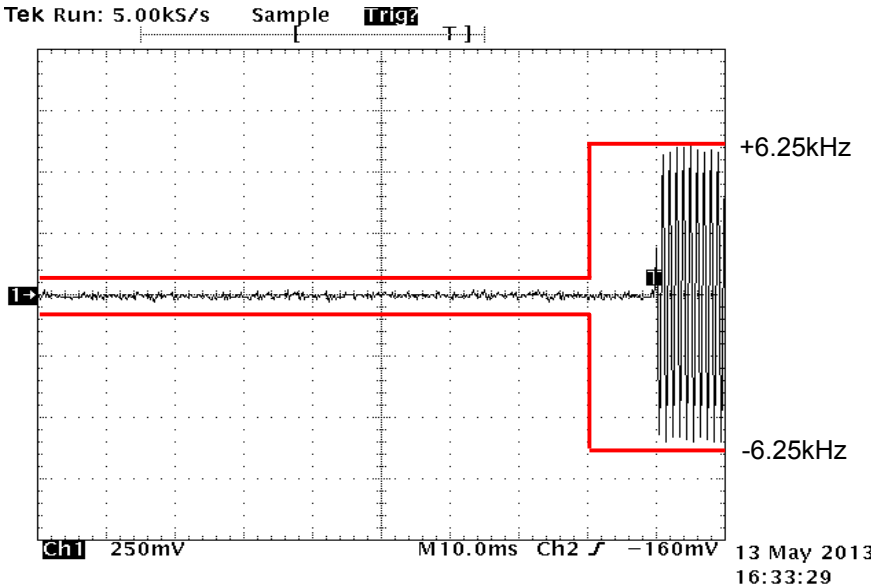

10.6 Audio Frequency Response / Audio Low Pass Filter (Voice Input)

REGULATIONS	: FCC Part 2 Section 1047 (a)
TEST METHOD/GUIDE	: ANSI/TIA-603-D Section 2.2.6.2.2, 3.2.6.2

Test Procedure

- 1 The EUT and test equipment were set up as shown on the following page.
- 2 Adjust the Modulation Analyzer for the following setting:
 - a) High-pass filter : 50 Hz
 - b) Low-pass filter : 15 kHz
 - c) Detector : positive peak
 - d) Function : FM
- 3 The audio signal input was adjusted to obtain 20 % modulation at 1 kHz, and this point was taken as the 0 dB reference level.
- 4 With input levels held constant and below limiting at all frequencies, the audio signal generator was varied from 300 Hz to 5 kHz.
- 5 The response in dB relative to 1 kHz was then measured, using the Modulation Analyzer.

Measuring Equipments

No.	Equipment	Manufacture	Model No.	Serial No.	Cal Date	Cal Exp.
1	Attenuator (20dB)	Aeroflex/Wenshel	66-20-34	BY4357	May 09, 12	May 31, 13
2	Attenuator (30dB)	Weinschel	WA-29-30-34	8923	May 09, 12	May 31, 13
3	Audio Generator	Anritsu	MG443B	M70150	Apr. 05, 13	Apr. 30, 14
4	Audio Analyzer	Hewlett Packard	8903B	2818A04372	May 18, 12	May 31, 13
5	Modulation Analyzer	Hewlett Packard	8901B	3403A04852	Aug. 09, 12	Aug. 31, 13
6	Digital Multi Meter	FLUKE	8846A	9642018	May 11, 12	May 31, 13
7	DC Power Supply	Daiichi denpa kogyo	GZV4000	90290931	None	None

Measuring Cables

No.	Cable	Manufacture	Model No.	Serial No.	Cal Date	Cal Exp.
W1	Coaxial Cable	Suhner	SUCOFLEX104	KSR00217	Dec. 20, 12	Dec. 31, 13
W4	Coaxial Cable	Pacific custom	RG-58 C/U	KSR00097	Dec. 21, 12	Dec. 31, 13
W6	Balance Cable	Nicoon	3D-2V	KSR00092	Dec. 21, 12	Dec. 31, 13
W9	Coaxial Cable	Pacific custom	RG-58 C/U	KSR00094	Dec. 21, 12	Dec. 31, 13

Measuring Equipment Configuration

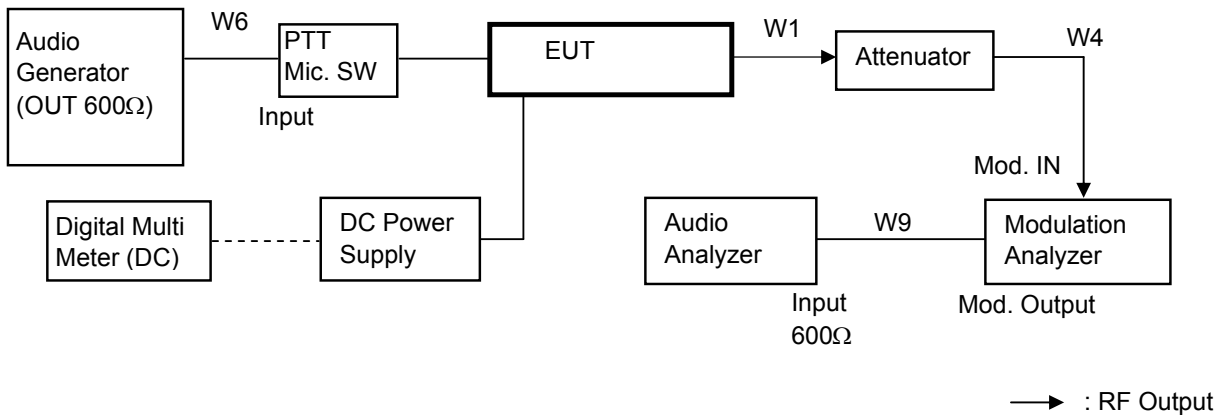

Test Results

Test date	May 16, 2013	
Location	Kashima No.1 Test Site	
temperature	21.9	[degree C]
Humidity Variation	68	[%]
Atmospheric Pressure	101	[kPa]
Test Engineer	Koichi Wagatsuma	

Test was carried out for all the frequency band of section 10.1
 State the worst case (below).

State : High Power / Authorized Bandwidth 20 kHz / 16K0F3E / 806.05 MHz(FCC / RSS) (Band 1)

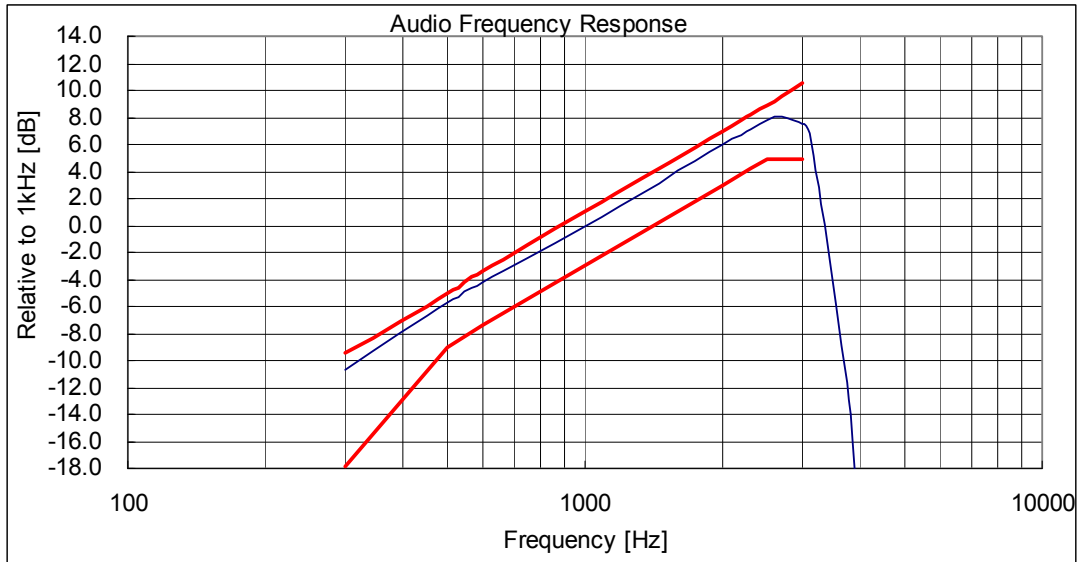

State : High Power / Authorized Bandwidth 20 kHz / 16K0F3E / 851.05 MHz(FCC / RSS) (Band 2)

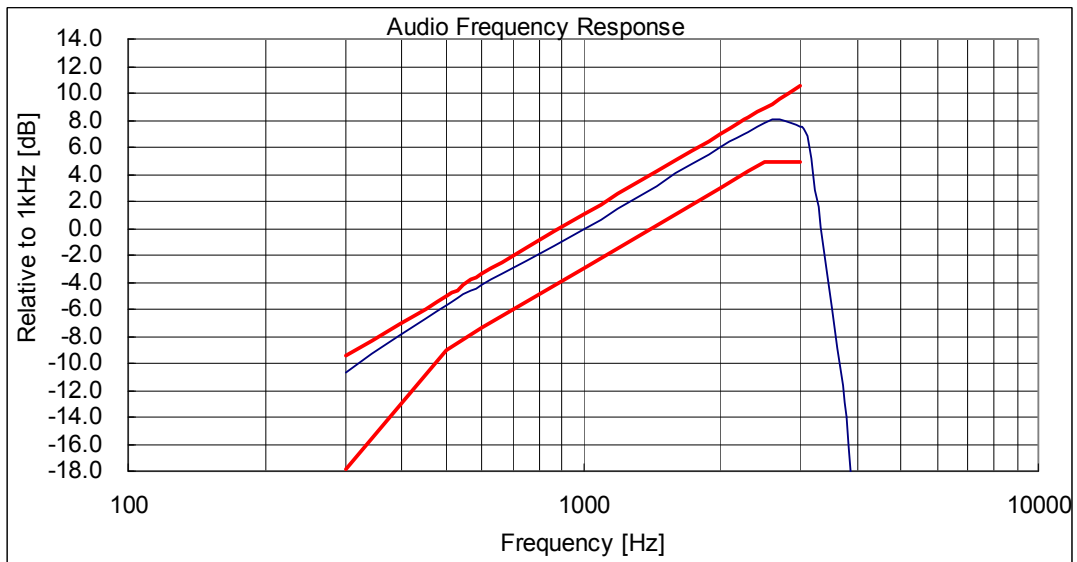

Note:

Audio Filter of the above result is substituted with the same structure as Audio Frequency Response.
 On the transmission condition below 3kHz,
 Transceiver shows pre-emphasis condition of transmission function.
 On the transmission condition above 3kHz, Transceiver shows Audio Low Pass Filter.

State : High Power / Authorized Bandwidth 20 kHz / 14K0F3E / 806.05 MHz(FCC / RSS) (Band 1)

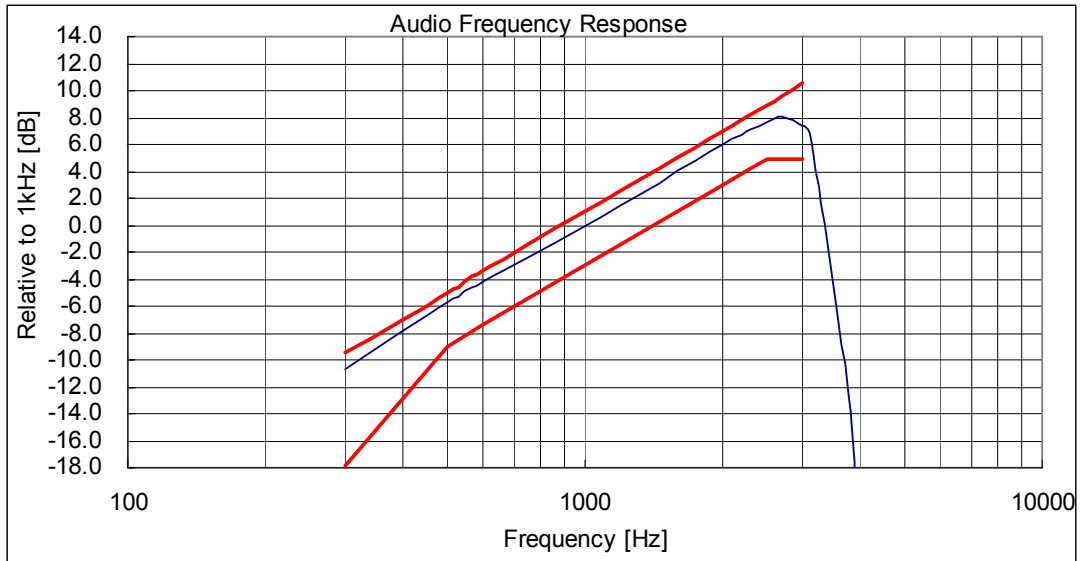

State : High Power / Authorized Bandwidth 20 kHz / 14K0F3E / 851.05 MHz(FCC / RSS) (Band 2)

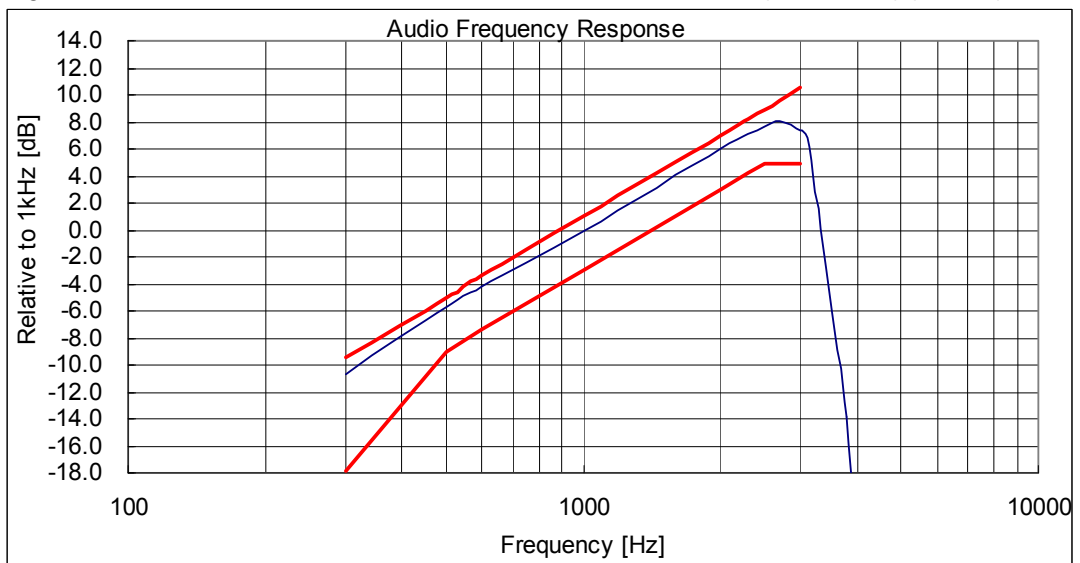

Note:

Audio Filter of the above result is substituted with the same structure as Audio Frequency Response.

On the transmission condition below 3kHz,

Transceiver shows pre-emphasis condition of transmission function.

On the transmission condition above 3kHz, Transceiver shows Audio Low Pass Filter.

State : High Power / Authorized Bandwidth 11.25 kHz / 11K0F3E / 806.05 MHz(FCC / RSS) (Band 1)

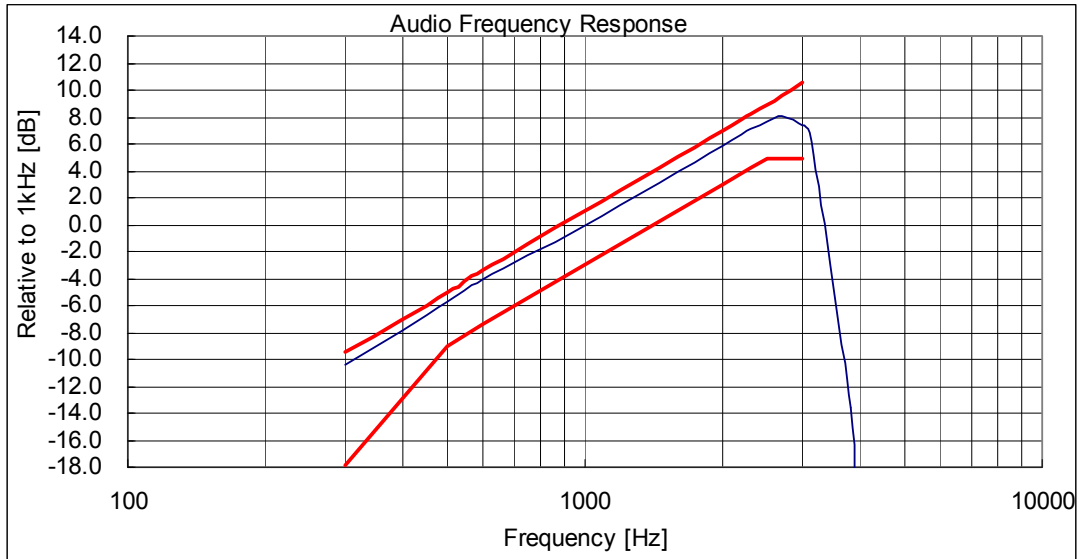

State : High Power / Authorized Bandwidth 11.25 kHz / 11K0F3E / 851.05 MHz(FCC / RSS) (Band 2)

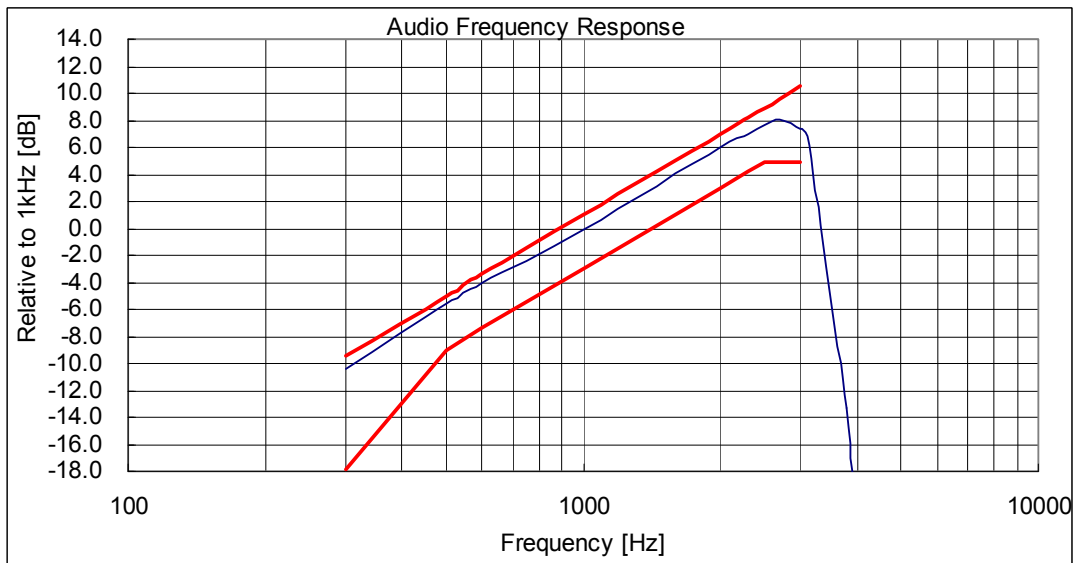

Note:

Audio Filter of the above result is substituted with the same structure as Audio Frequency Response.

On the transmission condition below 3kHz,

Transceiver shows pre-emphasis condition of transmission function.

On the transmission condition above 3kHz, Transceiver shows Audio Low Pass Filter.

10.7 Modulation Limiting

REGULATIONS	: FCC Part 2 Section 1047 (b)
TEST METHOD/GUIDE	: ANSI/TIA-603-D Section 2.2.3.2, 1.3.4.4

Test Procedure

- 1 The EUT and test equipment were set up as shown on the following page.
- 2 Adjust the Modulation Analyzer for the following setting:
 - a) High-pass filter : off
 - b) Low-pass filter : 15 kHz
 - c) Detector : positive peak
 - d) Function : FM
- 3 Apply a 1kHz modulation signal to the transmitter from the audio generator, and adjust the level to obtain 60% of full rated system deviation.
- 4 Measure the modulation frequency that was showed on the Modulation Analyzer when the output levels of the Audio Generator were changed from -20 dB to +50 dB by 10 dB.
- 5 Set the output frequencies of the Audio Generator 300 Hz and 3 kHz, and repeat test procedure 4.
- 6 Set the Detector of the Modulation Analyzer Negative Peak.
- 7 Repeat test procedure 4 and 5.

Measuring Equipments

No.	Equipment	Manufacture	Model No.	Serial No.	Cal Date	Cal Exp.
1	Attenuator (20dB)	Aeroflex/Wenshel	66-20-34	BY4357	May 09, 12	May 31, 13
2	Attenuator (30dB)	Weinschel	WA-29-30-34	8923	May 09, 12	May 31, 13
3	Audio Generator	Anritsu	MG443B	M70150	Apr. 05, 13	Apr. 30, 14
4	Modulation Analyzer	Hewlett Packard	8901B	3403A04852	Aug. 09, 12	Aug. 31, 13
5	Digital Multi Meter	FLUKE	8846A	9642018	May 11, 12	May 31, 13
6	DC Power Supply	Daiichi denpa kogyo	GZV4000	90290931	None	None

Measuring Cables

No.	Cable	Manufacture	Model No.	Serial No.	Cal Date	Cal Exp.
W1	Coaxial Cable	Suhner	SUCOFLEX104	KSR00217	Dec. 20, 12	Dec. 31, 13
W4	Coaxial Cable	Pacific custom	RG-58 C/U	KSR00097	Dec. 21, 12	Dec. 31, 13
W6	Balance Cable	Nicoon	3D-2V	KSR00092	Dec. 21, 12	Dec. 31, 13

Measuring Equipment Configuration

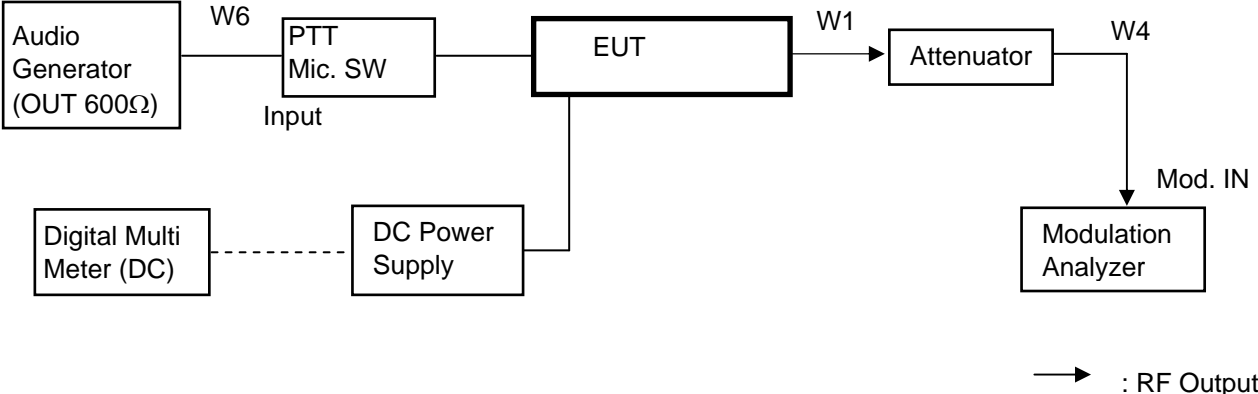

Test Results

Test date	May 17, 2013	
Location	Kashima No.1 Test Site	
temperature	23.2	[degree C]
Humidity Variation	50	[%]
Atmospheric Pressure	98.3	[kPa]
Test Engineer	Koichi Wagatsuma	

Test was carried out for all the frequency band of section 10.1
 State the worst case (below).

State : High Power / Authorized Bandwidth 20 kHz / 16K0F3E / 823.95 MHz(FCC / RSS) (Band 1)

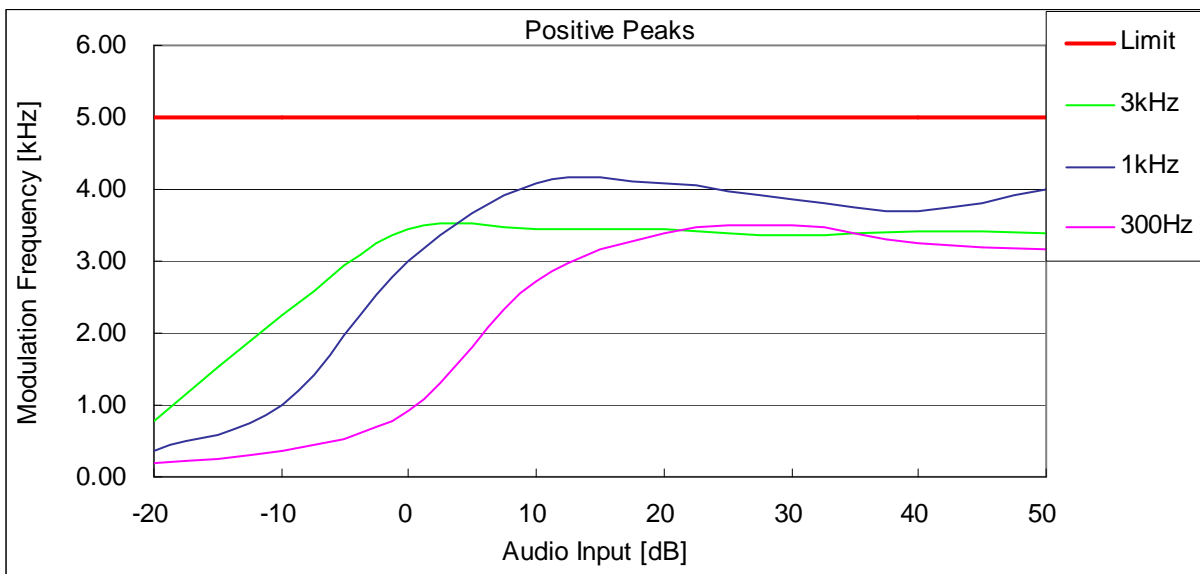

State : High Power / Authorized Bandwidth 20 kHz / 16K0F3E / 823.95 MHz(FCC / RSS) (Band 1)

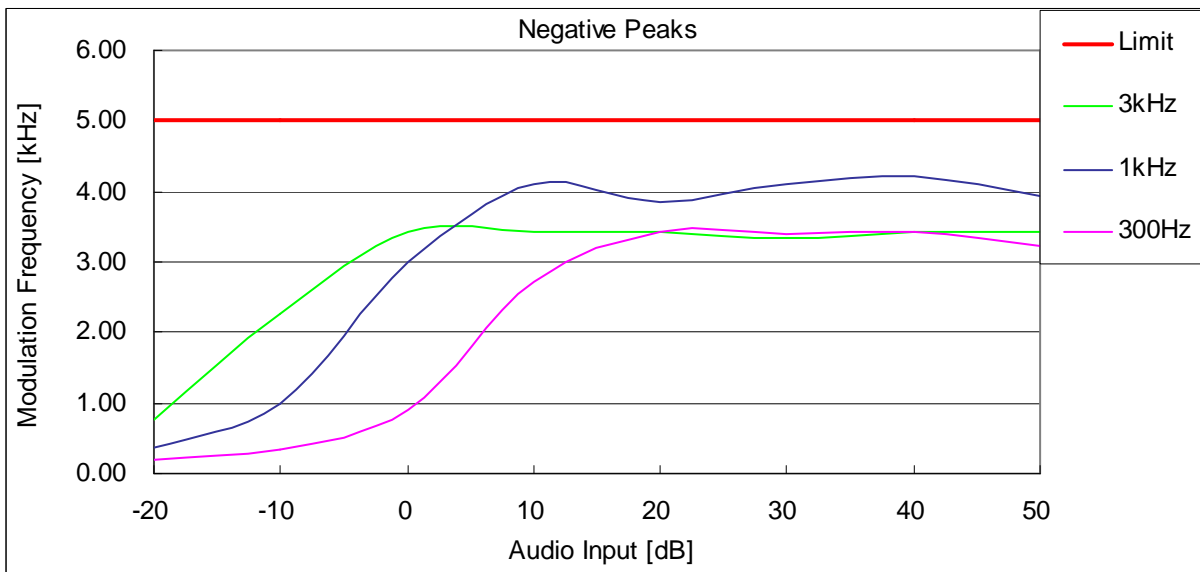

State : High Power / Authorized Bandwidth 20 kHz / 16K0F3E / 868.95 MHz(FCC / RSS) (Band 2)

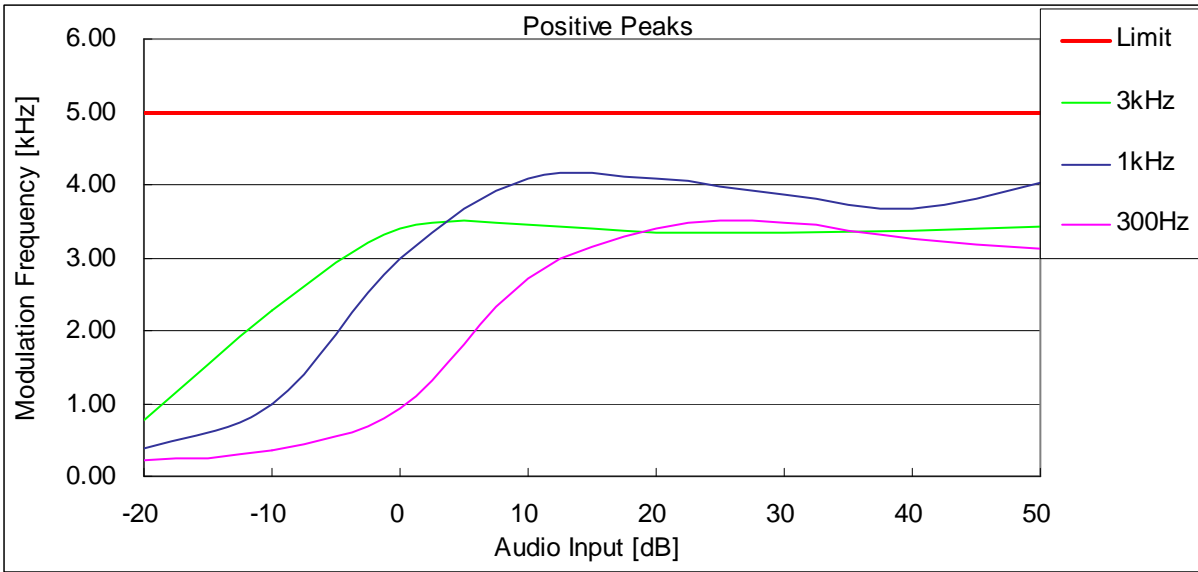

State : High Power / Authorized Bandwidth 20 kHz / 16K0F3E / 868.95 MHz(FCC / RSS) (Band 2)

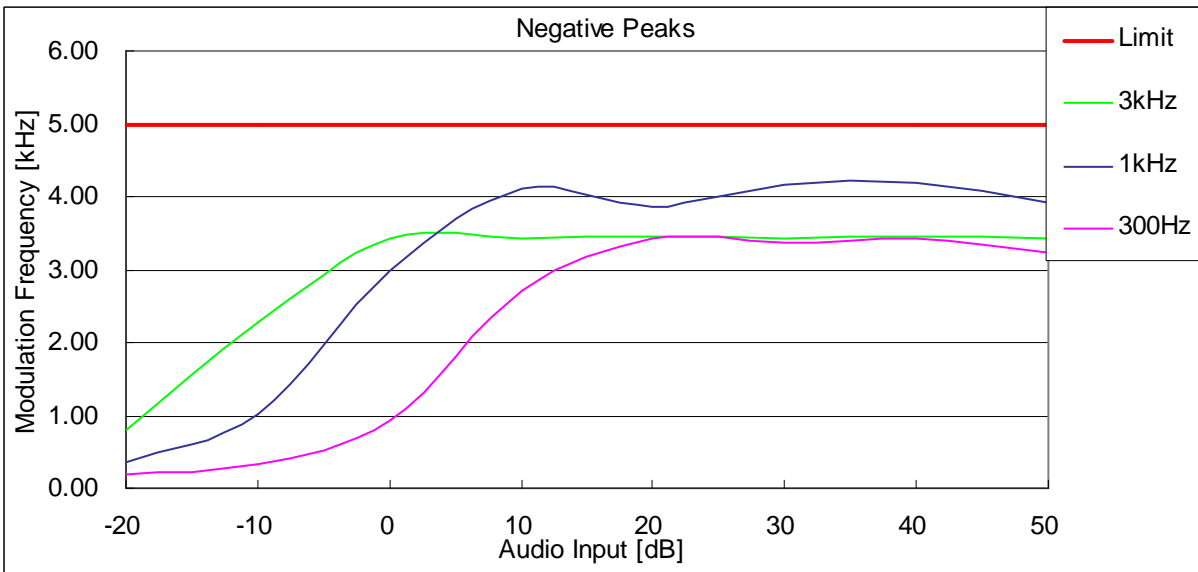

State : High Power / Authorized Bandwidth 20 kHz / 14K0F3E / 806.05 MHz(FCC / RSS) (Band 1)

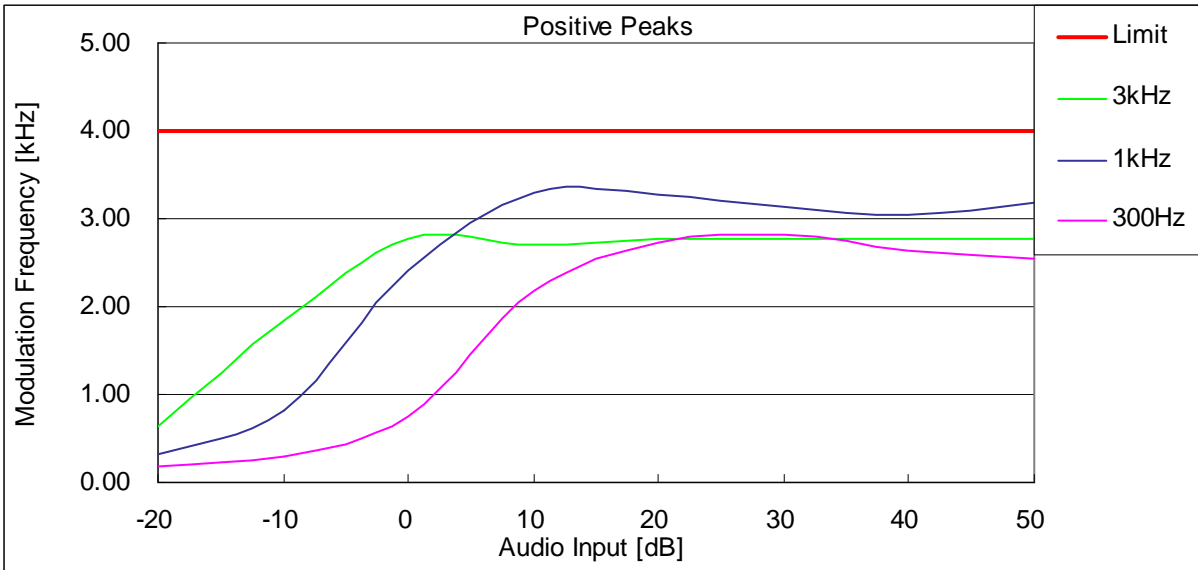

State : High Power / Authorized Bandwidth 20 kHz / 14K0F3E / 806.05 MHz(FCC / RSS) (Band 1)

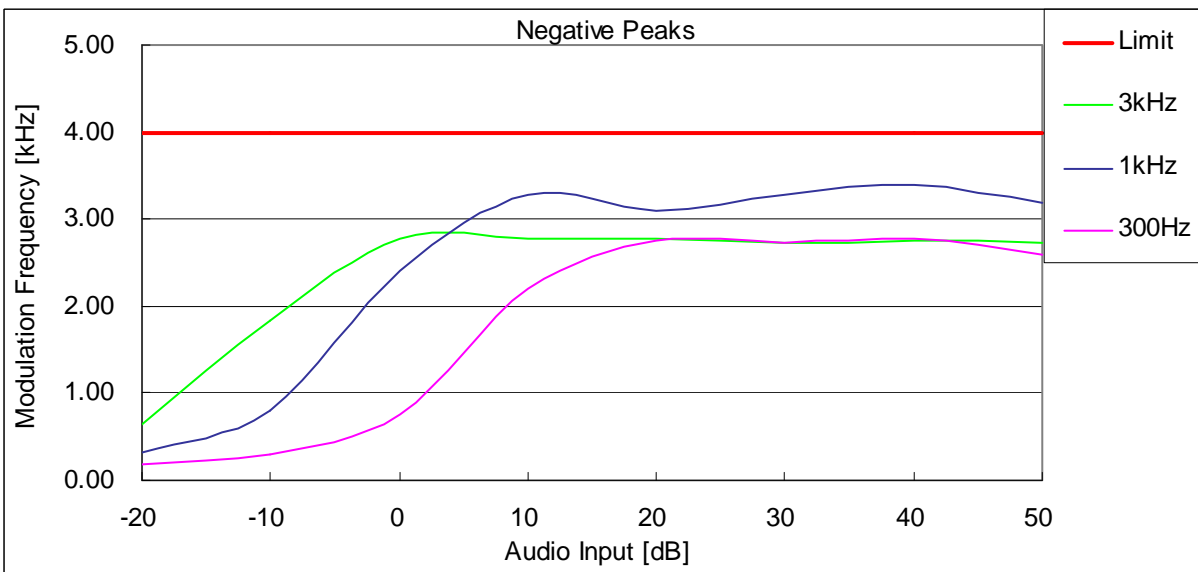

State : High Power / Authorized Bandwidth 20 kHz / 14K0F3E / 860.05 MHz(FCC / RSS) (Band 2)

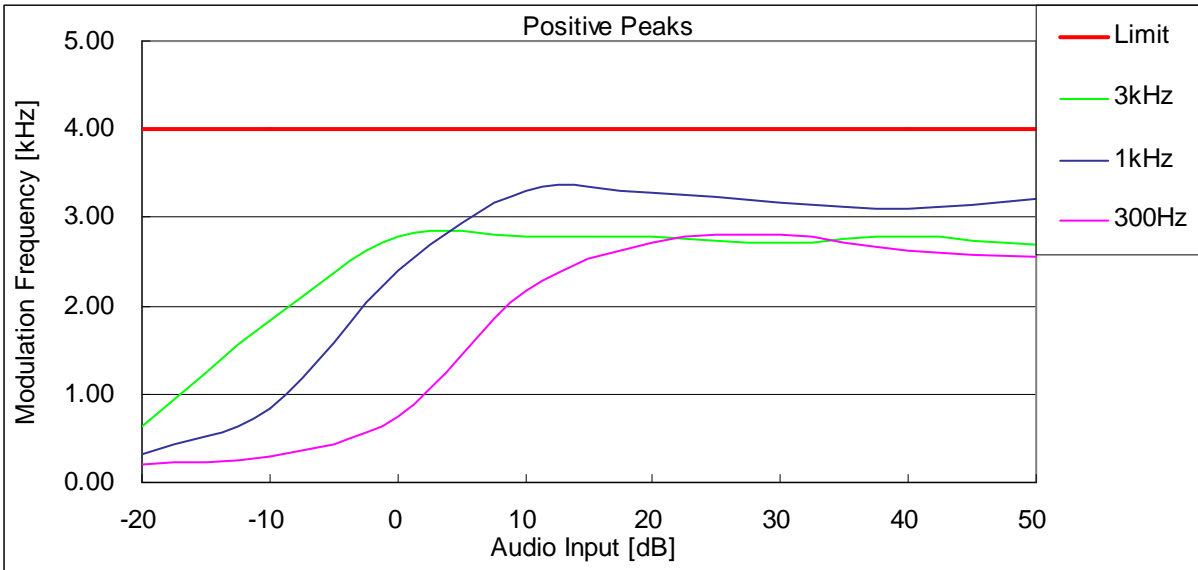

State : High Power / Authorized Bandwidth 20 kHz / 14K0F3E / 860.05 MHz(FCC / RSS) (Band 2)

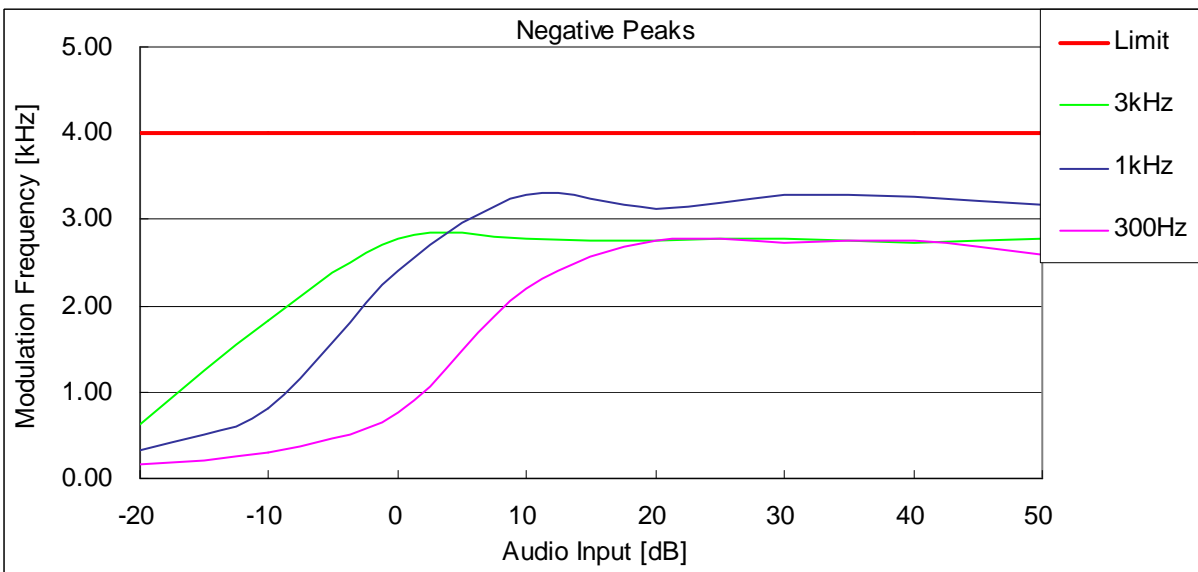

State : High Power / Authorized Bandwidth 11.25 kHz / 11K0F3E / 815.05 MHz(FCC / RSS) (Band 1)

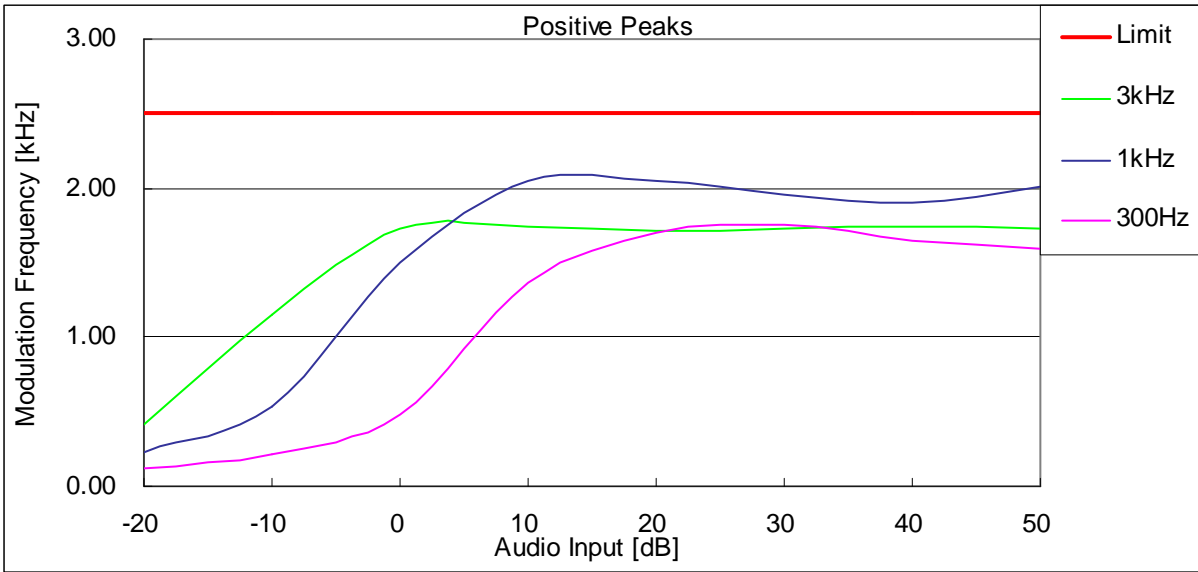

State : High Power / Authorized Bandwidth 11.25 kHz / 11K0F3E / 815.05 MHz(FCC / RSS) (Band 1)

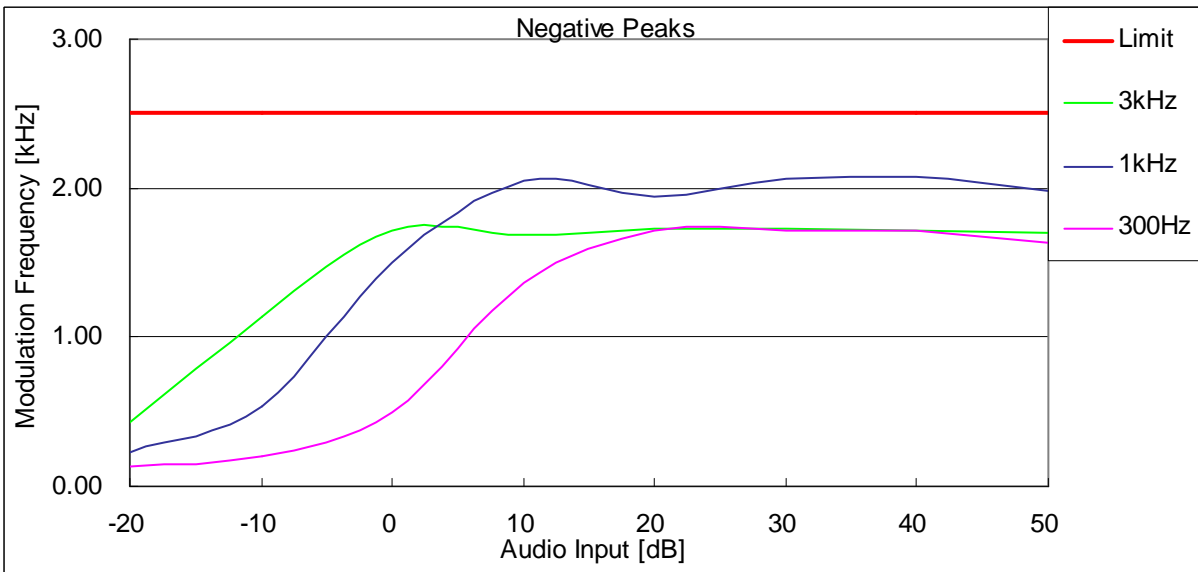

State : High Power / Authorized Bandwidth 11.25 kHz / 11K0F3E / 860.05 MHz(FCC / RSS) (Band 2)

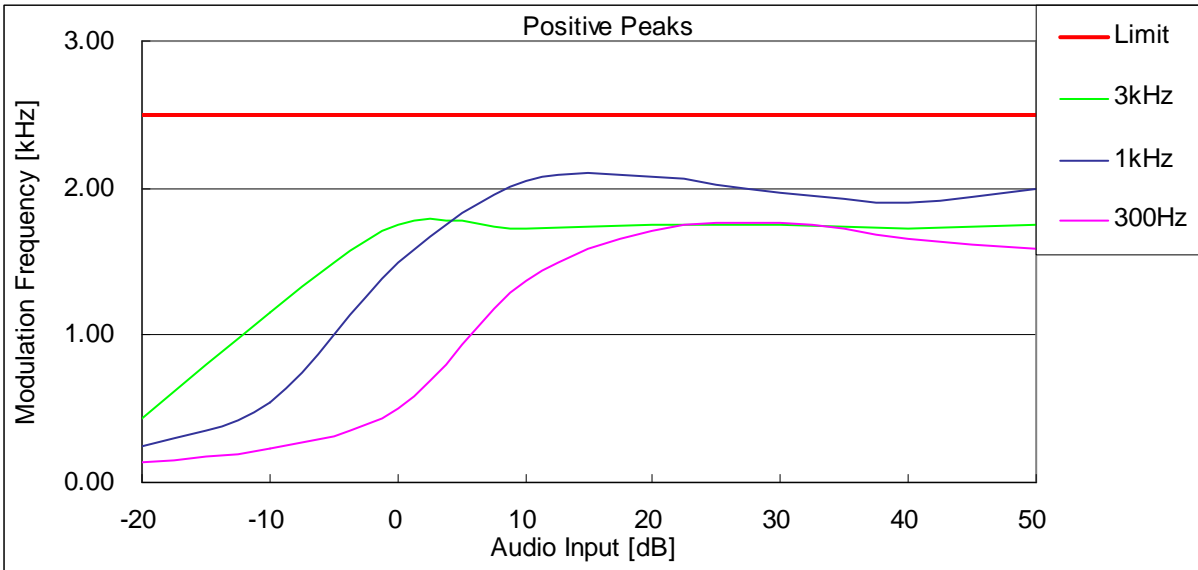

State : High Power / Authorized Bandwidth 11.25 kHz / 11K0F3E / 860.05 MHz(FCC / RSS) (Band 2)

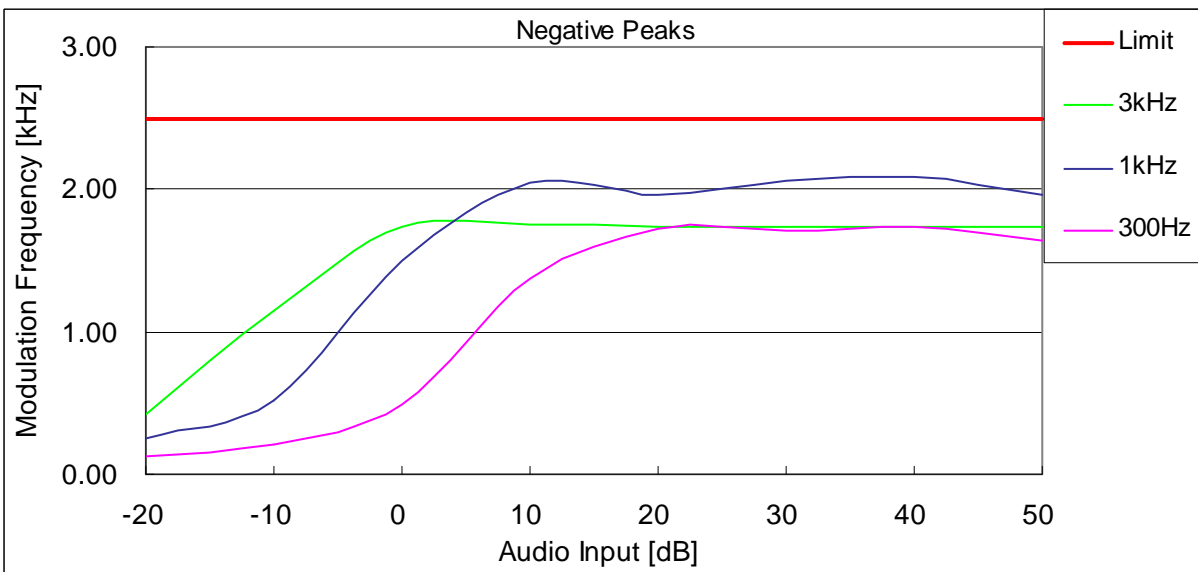

10.8 Frequency Stability (Temperature Variation)

REGULATIONS	: FCC Part 2 Section 1055 (a) (1), Part 90 Section 213(a) / RSS-119 Section 5.3
TEST METHOD/GUIDE	: ANSI/TIA-603-D Section 2.2.2.2 / RSS-Gen Section 4.7(a)

Test Procedure

- 1 The EUT and test equipment were set up as shown on the following page.
- 2 Set the temperature -30 degrees C.
- 3 Leave the EUT for 1 hour after it became the temperature that was set up.
- 4 Make the EUT the transmitting state.
One minutes later, measure the output frequency.
- 5 Make the EUT the receiving state.
- 6 Set the temperature 50 degrees C by 10 degrees C.
And repeat test procedure 3 to 5.

Measuring Equipments

No.	Equipment	Manufacture	Model No.	Serial No.	Cal Date	Cal Exp.
1	Attenuator (20dB)	Aeroflex/Wenshel	66-20-34	BY4357	May 09, 12	May 31, 13
2	Attenuator (30dB)	Weinschel	WA-29-30-34	8923	May 09, 12	May 31, 13
3	Modulation Analyzer	Hewlett Packard	8901B	2806A01669	May 15, 12	May 31, 13
4	Digital Multi Meter	FLUKE	8846A	9642018	May 11, 12	May 31, 13
5	DC Power Supply	Takasago	GP035-20R	1014199060	None	None
6	Temperature Chamber	Tabai	PL-3F	5103661	None	None
7	Temperature Meter	Sato	PC-5000TRH-II	A11999972	Apr. 08, 13	Apr. 30, 14
8	GPS Receiver	Hewlett Packard	HP Z3801A	3542A02414	None	None

Measuring Cables

No.	Cable	Manufacture	Model No.	Serial No.	Cal Date	Cal Exp.
W1	Coaxial Cable	Suhner	SUCOFLEX104	KSR00091	May 09, 12	May 31, 13
W3	Coaxial Cable	Suhner	SUCOFLEX104	KSR00042	May 09, 12	May 31, 13

Measuring Equipment Configuration

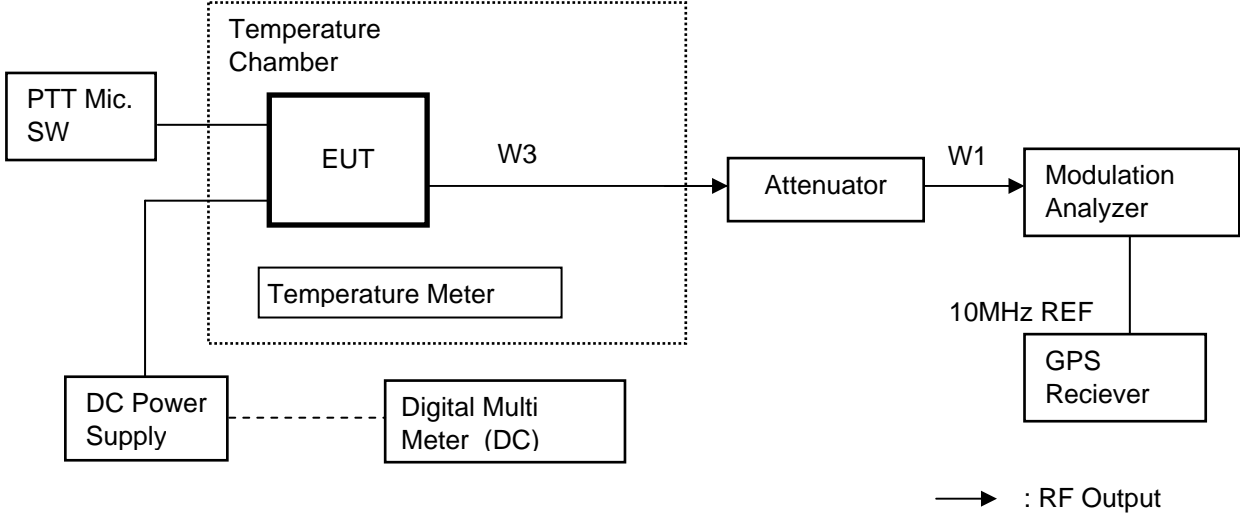

Test Results

Test date	May 20, 2013	to	May 21, 2013
Location	Kashima No.1 Test Site		
Test Engineer	Koichi Wagatsuma		

Test was carried out for all the frequency band of section 10.1
 State the worst case (below).

State : High Power / Authorized Bandwidth 20 kHz / 815.05 MHz (FCC/RSS) (Band 1)
 Reference Frequency: 815.050000 MHz(FCC Stability)
 815.049940 MHz(RSS Stability)

No.	Temperature (Degree C)	Frequency (MHz)	FCC Stability (ppm)	RSS Stability (ppm)	Limit (+/- ppm)	Min. Margin (ppm)
1	-30	815.049710	-0.36	-0.28	1.0	0.64
2	-20	815.049790	-0.26	-0.18	1.0	0.74
3	-10	815.050050	0.06	0.13	1.0	0.87
4	0	815.049990	-0.01	0.06	1.0	0.94
5	10	815.049990	-0.01	0.06	1.0	0.94
6	20	815.049940	-0.07	0.00	1.0	0.93
7	30	815.049820	-0.22	-0.15	1.0	0.78
8	40	815.049790	-0.26	-0.18	1.0	0.74
9	50	815.049890	-0.13	-0.06	1.0	0.87

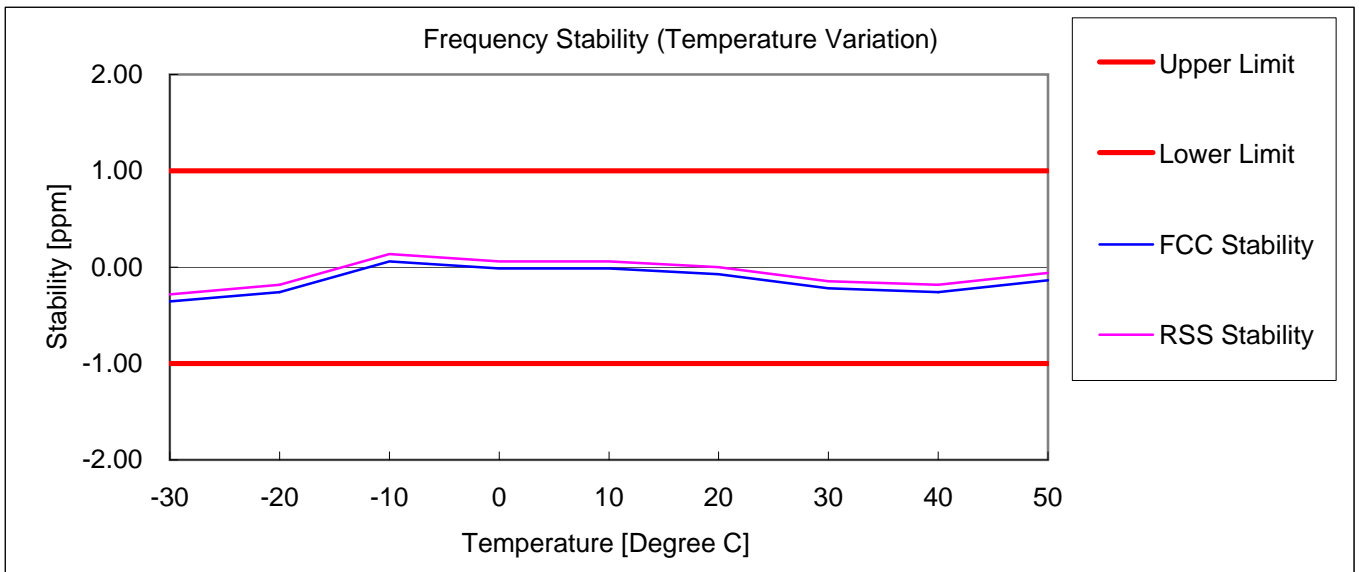

State : High Power / Authorized Bandwidth 20 kHz / 851.05 MHz (FCC/RSS) (Band 2)
 Reference Frequency: 851.050000 MHz(FCC Stability)
 851.049930 MHz(RSS Stability)

No.	Temperature (Degree C)	Frequency (MHz)	FCC Stability (ppm)	RSS Stability (ppm)	Limit (+/- ppm)	Min. Margin (ppm)
1	-30	851.049710	-0.34	-0.26	1.0	0.66
2	-20	851.049800	-0.24	-0.15	1.0	0.76
3	-10	851.050050	0.06	0.14	1.0	0.86
4	0	851.050000	0.00	0.08	1.0	0.92
5	10	851.049980	-0.02	0.06	1.0	0.94
6	20	851.049930	-0.08	0.00	1.0	0.92
7	30	851.049850	-0.18	-0.09	1.0	0.82
8	40	851.049800	-0.24	-0.15	1.0	0.76
9	50	851.049960	-0.05	0.04	1.0	0.95

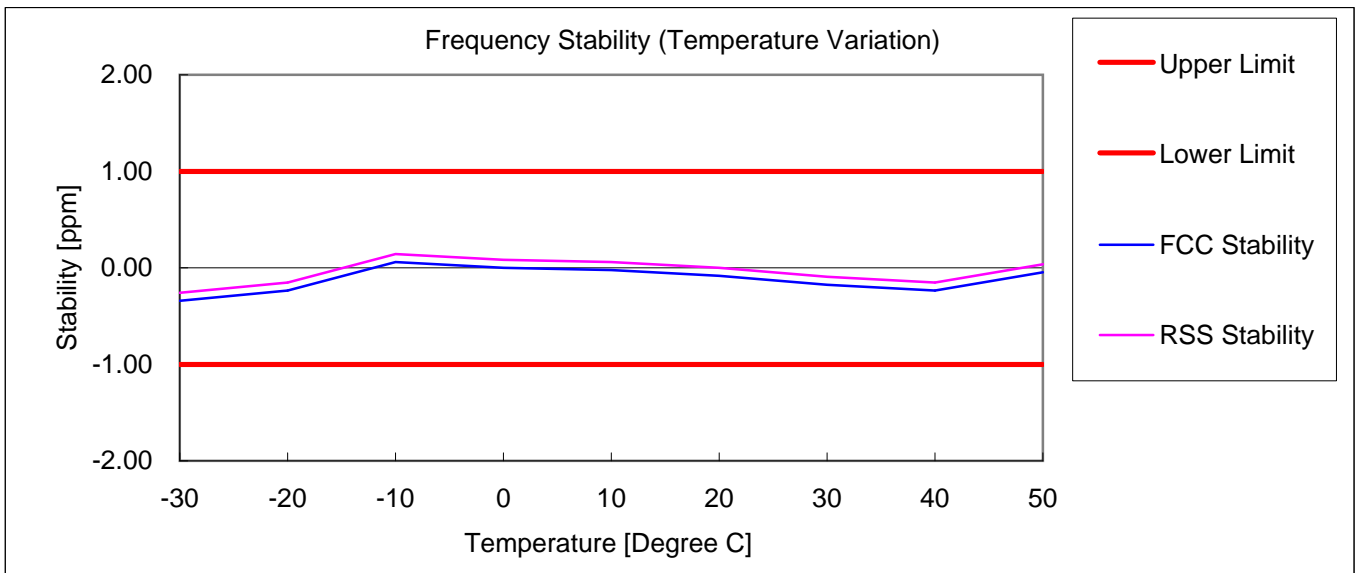

10.9 Frequency Stability (Voltage Variation)

REGULATIONS	: FCC Part 2 Section 1055 (d) (1), Part 90 Section 213(a) / RSS-119 Section 5.3
TEST METHOD/GUIDE	: ANSI/TIA-603-D Section 2.2.2.2 / RSS-Gen Section 4.7(b)

Test Procedure

- 1 The EUT and test equipment were set up as shown on the following page.
- 2 The power supply voltage to the EUT was varied from 85 % to 115 % of the nominal value measured at the input to the EUT.

Measuring Equipments

No.	Equipment	Manufacture	Model No.	Serial No.	Cal Date	Cal Exp.
1	Attenuator (20dB)	Aeroflex/Wenshel	66-20-34	BY4357	May 09, 12	May 31, 13
2	Attenuator (30dB)	Weinschel	WA-29-30-34	8923	May 09, 12	May 31, 13
3	Modulation Analyzer	Hewlett Packard	8901B	2806A01669	May 15, 12	May 31, 13
4	Digital Multi Meter	FLUKE	8846A	9642018	May 11, 12	May 31, 13
5	DC Power Supply	Takasago	GP035-20R	1014199060	None	None
6	Temperature Chamber	Tabai	PL-3F	5103661	None	None
7	Temperature Meter	Sato	PC-5000TRH-II	A11999972	Apr. 08, 13	Apr. 30, 14
8	GPS Receiver	Hewlett Packard	HP Z3801A	3542A02414	None	None

Measuring Cable:

No.	Cable	Manufacture	Model No.	Serial No.	Cal Date
W1	Coaxial Cable	Suhner	SUCOFLEX104	KSR00091	May 09, 12
W3	Coaxial Cable	Suhner	SUCOFLEX104	KSR00042	May 09, 12

Measuring Equipment Configuration

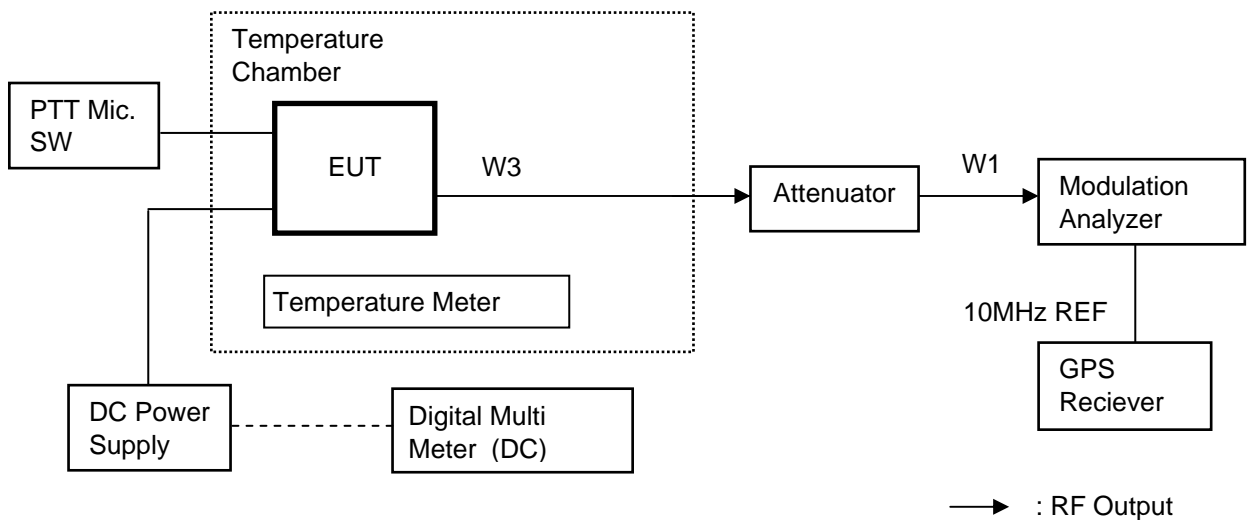

Test Results

Test date	May 21, 2013
Location	Kashima No.1 Test Site
Test Engineer	Koichi Wagatsuma

Test was carried out for all the frequency band of section 10.1

State the worst case (below).

Reference Frequency: 823.950000 MHz

State : High Power / Authorized Bandwidth 20 kHz / 823.95 MHz (FCC/RSS) (Band 1)

No.	Temperature (Degree C)	Diviation (%)	Voltage (V)	Frequency (MHz)	Stability (ppm)	Limit +/- (ppm)	Margin (ppm)
1	20+/-5	85	11.56	823.949940	-0.07	1.0	0.93
2	20+/-5	100	13.60	823.949950	-0.06	1.0	0.94
3	20+/-5	115	15.64	823.949940	-0.07	1.0	0.93

Reference Frequency: 868.950000 MHz

State : High Power / Authorized Bandwidth 20 kHz / 868.95 MHz (FCC/RSS) (Band 2)

No.	Temperature (Degree C)	Diviation (%)	Voltage (V)	Frequency (MHz)	Stability (ppm)	Limit +/- (ppm)	Margin (ppm)
1	20+/-5	85	11.56	868.949930	-0.08	1.0	0.92
2	20+/-5	100	13.60	868.949940	-0.07	1.0	0.93
3	20+/-5	115	15.64	868.949940	-0.07	1.0	0.93

10.10 Receiver Spurious Emissions(Radiated)

REGULATIONS	:	RSS-119 Section 5.11, RSS-Gen Section 6
TEST METHOD/GUIDE	:	RSS-Gen Section 4.10

TEST PROCEDURE

- 1 The EUT and test equipment were set up as shown on the following page.
- 2 Tabletop Equipment
EUT is placed on the wooden table, the top of which is 0.8meter above the metal ground plane(turntable).
- 3 Interconnecting Cables
Excess part of the interconnecting cables longer than 1 meter are bundled in the center. Cables that hang closer than 40 cm to the ground plane is folded back and forth forming bundle to 40 cm long, hanging approx, in the middle between ground plane and table.
- 4 Measuring Instruments
Measuring instruments list and their calibration schedule are shown on Measurement Equipment Configuration.
The brief description are as follows;
- 5 Antennas
The broadband Bi-cog antenna is used for measurement on the frequency range 30 – 1000 MHz.
The Double ridged guide antenna is used for frequency higher than 1000 MHz.
- 6 Pre-amplifier
The broadband pre-amplifier is used for radiated emission measurement.
The signal to noise ratio is improved by using pre-amplifier.
- 7 Spectrum Analyzer
The spectrum analyzer is used for preliminary measurement of frequency range 30 – 1000 MHz, and also used for final measurement of higher than 1000 MHz (RBW : 1 MHz).
- 8 EMI Test Receiver
The Quasi-peak detector (IF bandwidth : 120 kHz) built in test receiver is used for final measurement of the frequency 30 – 1000 MHz.
The test receiver is complied with the specification of the CISPR publication 16.
- 9 Turntable
The turntable is capable for EUT weight and rotatable 0 to 360 degree horizontally by remote control in the test room.
- 10 Antenna Mast
The antenna mast is attachable to all antennas described on antenna height is adjustable 1 to 4 meters continuously by remote control at the test room, and antenna polarization is also changed by the remote control.
- 11 Preliminary Measurement
EUT is tested on all operating conditions.
The spectrum analyzer is set max-hold mode and swept during turntable was rotated 0 to 360 degree. Then spectrum chart are plotted out to find the worst emission conditions in configuration, operating mode, or ambient noise notation.

12 Final Measurement

The EUT operated in the condition where maximum emission is found in the preliminary test.

The turntable azimuth(EUT direction) and antenna height are adjusted the position so that maximum field strength is obtained for each frequency spectrum to be measured.

The equipment and cables are arranged or manipulated within the range of the test standard in the above condition.

When the uncertain result was obtained, the measurement is retried by using the half wave dipole antenna instead of the broadband antenna.

TEST EQUIPMENTS

No.	Equipment	Manufacture	Model No.	Serial No.	Cal Date	Cal Exp.
1	Broad Band Antenna	ARA	LPB-2513/A	1103	Oct. 04, 12	Oct. 31, 13
2	6dB Attenuator	TME	UFA-01	None	Jan. 11, 13	Jan. 31, 14
3	Amplifier	Intertek Japan	ZX60-3018G	005	Jan. 11, 13	Jan. 31, 14
4	RF Switch	Intertek Japan	ACX-150-1	None	Jan. 11, 13	Jan. 31, 14
5	Test Receiver	Rohde & Schwarz	ESS (Rev 1.07)	847151/012	Mar. 25, 13	Mar. 31, 14
6	Double Ridged Antenna	EMCO	3115	5044	Jul. 03, 12	Jul. 31, 13
7	3dB Attenuator	SUHNER	6803.17.B	None	Oct. 02, 12	Oct. 31, 13
8	Amplifier	TOYO	TPA0118-30	402	Oct. 02, 12	Oct. 31, 13
9	Spectrum Analyzer	Agilent	N9030A (Rev.A,08,54)	US51350170	Jan. 25, 13	Jan. 31, 14
10	Dummy Load	TME	CT-150NP	1138693	Dec. 21, 12	Dec. 31, 13
11	Digital Multi Meter	FLUKE	8846A	9642018	May 11, 12	May 31, 13
12	DC Power Supply	KIKUSUI	PMC35-3A	LE000716	None	None

USED CABLES

No.	Cable	Manufacture	Model No.	Serial No.	Cal Date	Cal Exp.
W13	Coaxial Cable	Suhner	SUCOFLEX106	KSR00207	May 09, 12	May 31, 13
R1	Coaxial Cable	Intertek	RG-5A/U	None	Jan. 11, 13	Jan. 31, 14
R3	Coaxial Cable	Intertek	RG-5A/U	None	Jan. 11, 13	Jan. 31, 14
R5	Coaxial Cable	Intertek	RG-5A/U	None	Jan. 11, 13	Jan. 31, 14
R7	Coaxial Cable	Intertek	5D-2W	None	Jan. 11, 13	Jan. 31, 14
R10	Coaxial Cable	Intertek	5D-2W	None	Jan. 11, 13	Jan. 31, 14
R11	Coaxial Cable	RADIALL	R286401344	03 23 72	Oct. 02, 12	Oct. 31, 13
R12	Coaxial Cable	RADIALL	R286401343	03 23 104	Oct. 02, 12	Oct. 31, 13

MEASUREMENT EQUIPMENT CONFIGURATION

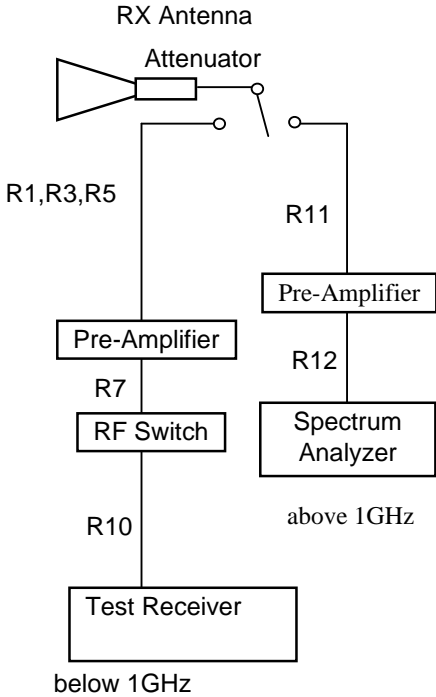
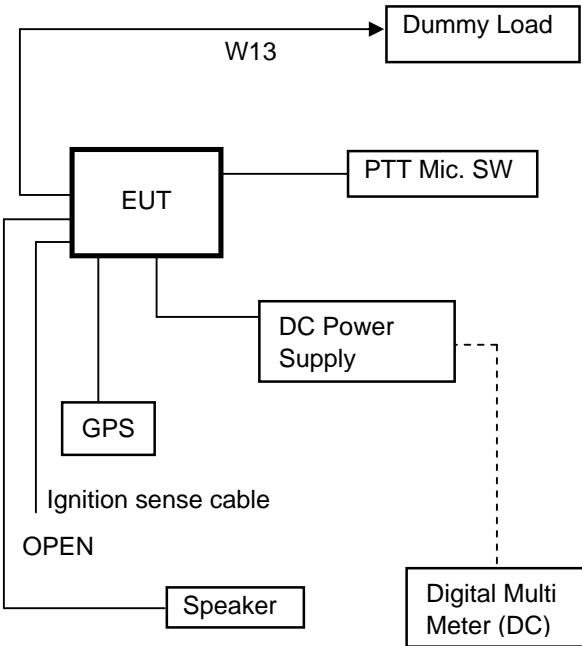

TEST RESULTS

Test date	Apr. 30, 2013 to May 01, 2013
Location	Kashima No.12 Test Site
temperature	20.5 to 23.0 [degree C]
Humidity Variation	50 to 55 [%]
Atmospheric Pressure	99.5 to 99.8 [kPa]
Test Engineer	Koichi Wagatsuma

Test was carried out for the RSS frequency band of section 10.1
 State the worst case (below).

State : 860.05 MHz Receiver Condition

No.	Frequency (MHz)	Pol	Mode	Reading Level (dBuv)	Factor* (dB)	Emission Level (dBuV/m)	Limit Level (dBuV/m)	Margin (dB)
1	405.06	Hor.		22.70	4.70	27.40	46.0	18.6
		Ver.		-	4.70	-	46.0	-
2	810.11	Hor.		23.30	13.60	36.90	46.0	9.1
		Ver.		21.70	13.60	35.30	46.0	10.7
3	1215.17	Hor.	AVG	36.80	-4.90	31.90	54.0	22.1
		Ver.	AVG	42.30	-4.90	37.40	54.0	16.6
4	2025.28	Hor.	AVG	44.70	-2.50	42.20	54.0	11.8
		Ver.	AVG	44.60	-2.50	42.10	54.0	11.9
5	2430.30	Hor.	AVG	40.20	-1.10	39.10	54.0	14.9
		Ver.	AVG	44.10	-1.10	43.00	54.0	11.0
6	2835.36	Hor.	AVG	42.30	0.10	42.40	54.0	11.6
		Ver.	AVG	51.70	0.10	51.80	54.0	2.2
7	4050.51	Hor.	AVG	41.30	2.90	44.20	54.0	9.8
		Ver.	AVG	43.50	2.90	46.40	54.0	7.6
8	4860.60	Hor.	AVG	38.20	3.80	42.00	54.0	12.0
		Ver.	AVG	39.10	3.80	42.90	54.0	11.1
9	6480.79	Hor.	AVG	32.10	6.40	38.50	54.0	15.5
		Ver.	AVG	33.90	6.40	40.30	54.0	13.7

There is the margin of 20dB over except for the above points.

* Factor = Antenna, Antenna Pad, Cable, Preamp

Emission Level = Reading Level + Factor

Note:

- 1 Measurement distance is 3 metres.
- 2 Scanned frequency are 30 to 16000 MHz.
- 3 Highest oscillator frequency is 3144.84 MHz.
(RX UNIT : 870MHz)

10.11 Necessary Bandwidth and Emission Bandwidth

REGULATIONS	: FCC Part 2 Section 202 (g) & Federal Register/ Vol.68, No236 TRC 43
-------------	--

Calculation Results

State : 16K0F3E (Authorized Bandwidth 20 kHz)

Item	Mark		
Maximum Modulation	(M)	3	kHz
Maximum Deviation	(D)	5	kHz
Constant Factor	(K)	1	
Necessary Bandwidth	(Bn)	16	kHz

$$Bn = (2xM)+(2xDxK)$$

State : 14K0F3E (Authorized Bandwidth 20 kHz)

Item	Mark		
Maximum Modulation	(M)	3	kHz
Maximum Deviation	(D)	4	kHz
Constant Factor	(K)	1	
Necessary Bandwidth	(Bn)	14	kHz

$$Bn = (2xM)+(2xDxK)$$

State : 11K0F3E (Authorized Bandwidth 11.25 kHz)

Item	Mark		
Maximum Modulation	(M)	3	kHz
Maximum Deviation	(D)	2.5	kHz
Constant Factor	(K)	1	
Necessary Bandwidth	(Bn)	11	kHz

$$Bn = (2xM)+(2xDxK)$$

State : 8K30F1E / 8K30F1D / 8K30F7W (4Level FSK / 9600bps, Authorized Bandwidth 11.25 kHz)

Item	Mark		
Digital information rate	(R)	9600	bps
Peak frequency deviation	(D)	3.391	kHz
Signaling states	(S)	4	
Numerical factor	(K)	0.516	
Necessary Bandwidth	(Bn)	8.3	kHz

$$Bn = (R/\log_2S)+2xDxK$$

State : 4K00F1E / 4K00F1D / 4K00F7W (4Level FSK / 4800bps, Authorized Bandwidth 6 kHz)

Item	Mark		
Digital information rate	(R)	4800	bps
Peak frequency deviation	(D)	1.55	kHz
Signaling states	(S)	4	
Numerical factor	(K)	0.516	
Necessary Bandwidth	(Bn)	4	kHz

$$B_n = (R/\log_2 S) + 2x D x K$$

State : 4K00F2D (CWID, Authorized Bandwidth 6 kHz)

Item	Mark		
Maximum Modulation	(M)	0.8	kHz
Maximum Deviation	(D)	1.2	kHz
Numerical factor	(K)	1	
Necessary Bandwidth	(Bn)	4	kHz

$$B_n = (2xM) + (2x D x K)$$