



TEST REPORT

STANDARD : FCC Part15B Class B -Peripherals-

Applicant	Testing Laboratory
JVC KENWOOD Corporation 1-16-2, Hakusan, Midori-ku, Yokohama-shi, Kanagawa, 226-8525 Japan Tel. +81 45 939 6254	Intertek Japan K.K. Tochigi Laboratory URL: http://www.japan.intertek-etlsemko.com 870, Nakaawano, Kanuma-shi, Tochigi-ken 322-0306 Japan Tel. +81 289 86 7121

Equipment Type	144/220/430MHz TRIBANDER
Trademark	KENWOOD
Model(s)	TH-D74A
Serial No.	FES2 K-08
Equipment Authorization	Certification (FCC ID : K44440900)
Test Result	Complied
Report Number	16050300JKA-002
Original Issue Date	June 23, 2016
Revised Issue Date	July 04, 2016

This report is for the exclusive use of Intertek's Client and is provided pursuant to the agreement between Intertek and its Client. Intertek's responsibility and liability are limited to the terms and conditions of the agreement. Intertek assumes no liability to any party, other than to the Client in accordance with the agreement, for any loss, expense or damage occasioned by the use of this report. Only the Client is authorized to permit copying or distribution of this report and then only in its entirety. Any use of the Intertek name or one of its marks for the sale or advertisement of the tested material, product or service must first be approved in writing by Intertek. The observations and test results in this report are relevant only to the sample tested. This report by itself does not imply that the material, product, or service is or has ever been under an Intertek certification program.

Approved by

Koji Setoguchi
[Technical Manager]

Tested by

Koichi Wagatsuma
[Engineer]



VLAC-008-5

Responsible Party of Test Item (Product)

Responsible Party	:
Add.	:
Tel.	:
Fax.	:
Contact Person	:

TABLE OF CONTENTS

	Page
SECTION 1. GENERAL INFORMATION	3
SECTION 2. SUMMARY OF TEST RESULTS	4
SECTION 3. EQUIPMENT UNDER TEST	5
SECTION 4. SUPPORT EQUIPMENT.....	6
SECTION 5. USED CABLE(S).....	7
SECTION 6. TEST CONFIGURATION	8
SECTION 7. OPERATING CONDITION	9
SECTION 8. UNCERTAINTY	10
SECTION 9. EVALUATION OF TEST RESULTS	11
SECTION 10. LIST OF MEASURING INSTRUMENTS.....	50
ANNEX	51
APPENDIX PHOTOGRAPHS OF MAXIMUM EMISSION SET-UP	

SECTION 1. GENERAL INFORMATION

Test Performed

EUT Received	May 26, 2016
Date of Test	From May 30, 2016 to June 8, 2016
Standard Applied	FCC Part15B -Peripherals-
Test methods	ANSI C63.4-2014
Deviation from Standard(s)	None

Qualifications of Testing Laboratory

Accreditation	Scope	Lab. Code	Remarks
VLAC	EMC Testing	VLAC-008-5	JAPAN
Filing			
VCCI	EMC Testing	A-0129	JAPAN
FCC	EMC Testing	Designation Number : JP0011	USA
IC	EMC Testing	2042P-1, 2042P-2, 2042P-3	CANADA
SAUDI ARABIA	EMC Testing	N/A	

Abbreviations

EUT	: Equipment Under Test	DoC	: Declaration of Conformity
AMN	: Artificial Mains Network	ISN	: Impedance Stabilization Network
LISN	: Line Impedance Stabilization Network	Q-P	: Quasi-peak
AMP	: Amplifier	AVG	: Average
ATT	: Attenuator	PK	: Peak
ANT	: Antenna	Cal	: Calibration
BBA	: Broadband Antenna	N/A	: Not applicable or Not available
DIP	: Dipole Antenna	LCD	: Liquid-Crystal Display
AE	: Associated Equipment	HDMI	: High-Definition Multimedia Interface

Revision Summary

Revised Date	Section	Description of Changes
June 30, 2016	7	Add "EUT receives data from Computer."
June 30, 2016	10	Add "All measurements equipment used for the measurement is calibrated based on standard." Add "Each measurement result is traceable to national or international standards."
July 04, 2016	10	Add "Antenna used for the measurement is calibrated based on the ANSI C63.5."

SECTION 2. SUMMARY OF TEST RESULTS

See Section9 for the detailed result.

Emission Tests

Standard Applied	FCC Part15B -Peripherals-	
Test Item	Minimum margin	Remarks
Conducted disturbance at mains terminals	22.0 dB (0.2140 MHz) [Q-P] RX mode(262.00MHz:Band B) 22.0 dB (0.2153 MHz) [Q-P] RX mode(523.995MHz:Band B)	
Radiated disturbance	4.4 dB (30.90 MHz) RX mode(238.00MHz:Band A) 4.4 dB (30.90 MHz) RX mode(259.995MHz:Band A)	

SECTION 3. EQUIPMENT UNDER TEST

The equipment under test (EUT) consisted of the following apparatus.

3.1 System Configuration

Symbol	Item	Model No.	Serial No.	Manufacturer	Remarks
A	144/220/430MHz TRIBANDER	TH-D74A	FES2 K-08	JVC KENWOOD	
Rated Power : DC-IN Terminal: DC 13.8 V (DC 12 - 16 V) Battery Terminal: DC 7.4 V DC (DC 5.5V - 10.8 V), 0.38 A max.					
Supplied Power :DC 13.8V					
Condition of Equipment		Prototype			
Type		Tabletop			
Suppression Devices		No Modifications by the laboratory were made to the device			

3.2 Overview of EUT

Frequency Ranges	136 – 174 MHz , 216 – 260 MHz and 410 – 470 MHz (Band A) 0.1 – 524 MHz (Band B)
Conversion Type	Double conversion (F3E, F2D, F7W) Triple conversion (A1A, A3E, J3E)

3.3 Intermediate frequency

1st	57.15 MHz (Band A) or 58.05 MHz (Band B)
2nd	450 kHz (Band A and Band B)
3rd	10.8 kHz (Band B)

3.4 Port(s)/Connector(s)

Port Name	Connector Type	Connector Pin	Remarks
DC Jack	3.75Φ	2 pin	
External Microphone Jack	3.5Φ	3 pin	
External Speaker Jack	2.5Φ	3 pin	
USB Socket	Mini USB plug B	5 pin	
microSD Slot	microSD Slot	12 pin	
SMA Connector (Antenna)	SMA5.35Φ	2 pin	
Battery Terminal Connector	BZ type	3 pin	

3.5 Highest Frequency Generated / Used

Operating Frequency	Operating mode	Remarks
524 MHz	RX mode	
4960 MHz	RX mode	Bluetooth Unit

SECTION 4. SUPPORT EQUIPMENT

The EUT was supported by the following equipment during the test.

Symbol	Item	Model No.	Serial No.	Manufacturer	Remarks	FCC ID
B	WHIP Antenna	T9A-0034-00	No.106	JVC KENWOOD		N/A
C	Li-ion battery pack	KNB-75L	No.1	JVC KENWOOD		N/A
D	microSDHC card	Y08GI30	MDS4071062	JVC KENWOOD		DoC
E	Speaker microphone	SMC-34	No.1	JVC KENWOOD		N/A
F	Earphone	HS-9	No.1	JVC KENWOOD		N/A
G	DC Power Supply	PS-60	11/01 00148	JVC KENWOOD		N/A
H	Computer	XL510AV	JPA231S7XJ	HP		DoC
I	Keyboard	SK-8115	CN-0DJ319-7161 6-89B-0MJS	DELL		DoC
J	Mouse	MOC5UO	H1206664	DELL		DoC
K	LCD	E172FPb	CN-0N1532-4663 3-41G-0947	DELL		DoC
L	Hub	LSW4-GT-8E P/WH	16486394423402	Buffalo		DoC
M	AC Adapter	US100523	B10-0155491	Buffalo		N/A
Supplied Power:						
G, H, K, M	AC120 V, 60 Hz					

SECTION 5. USED CABLE(S)

The following cable(s) was used for the test.

No.	Name	Length (m)	Shield	Metal Connector	Ferrite Core
1	Speaker microphone Cable	0.48	No	No	
2	Earphone Cable	1.00	No	No	
3	USB Cable	1.00	Yes	Yes	
4	Keyboard Cable	2.05	Yes	Yes	Fixed x 1
5	Mouse Cable	1.80	Yes	Yes	
6	Video Cable	1.80	Yes	Yes	Fixed x 2
7	LAN Cable	2.00	No	No	
8	Power for TH-D74A (DC)	1.40	No	No	
9	Power for Hub (DC)	2.00	No	No	
10	Power cable for DC Power Supply (AC)	2.50	No	No	
11	Power cable for Computer (AC)	1.80	No	No	
12	Power cable for LCD (AC)	1.75	No	No	

Note :

No.4 cable is supplied together with Keyboard (I)

No.6 cable is supplied together with LCD(K)

SECTION 6. TEST CONFIGURATION

6.1 Conducted disturbance at mains terminals Tests and Radiated disturbance tests

* : EUT
■ : Ferrite core

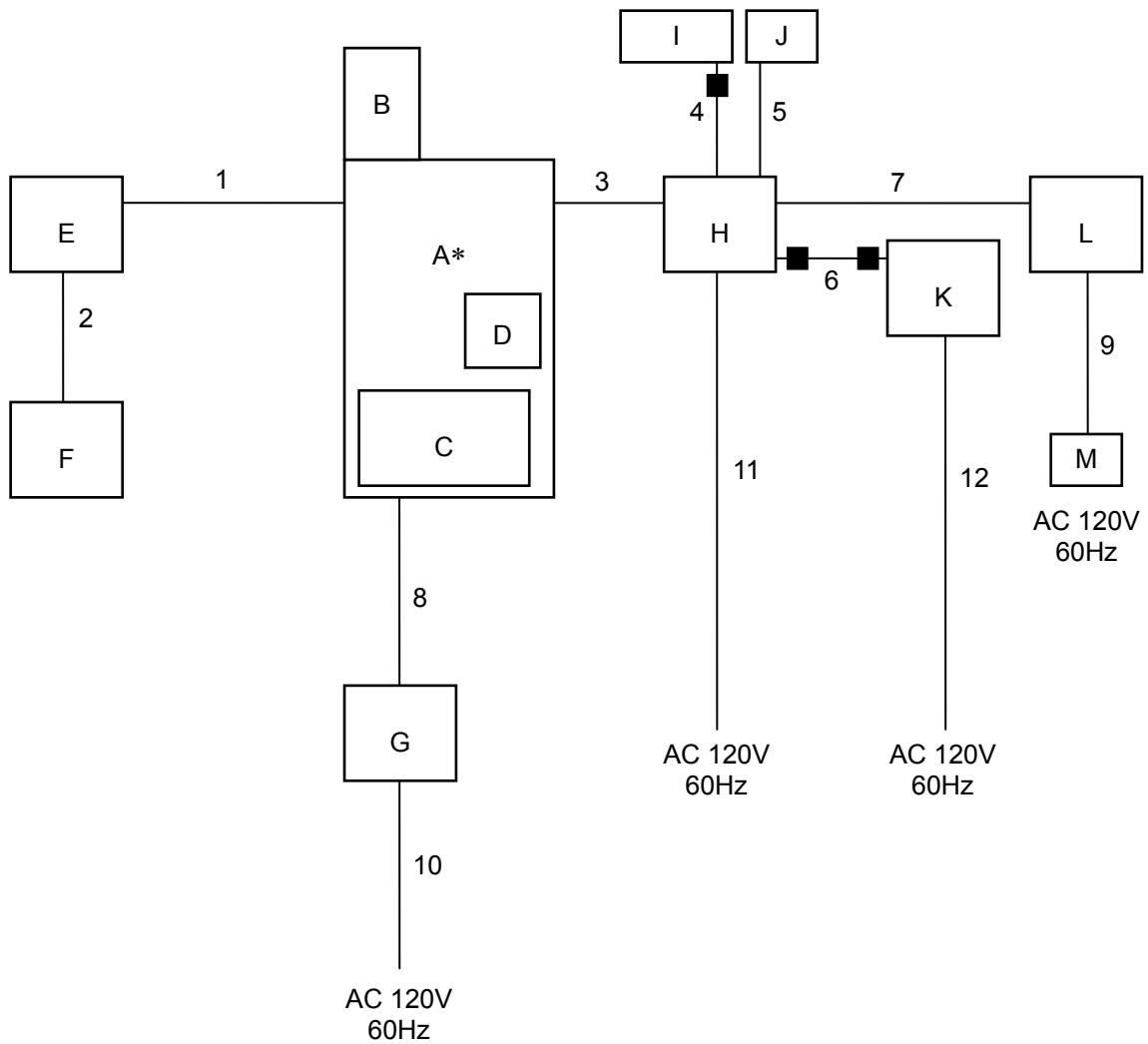

The symbols and numbers assigned to the equipments and cables on this diagram correspond to the ones in Sections 3 to 5.

SECTION 7. OPERATING CONDITION

The test was carried out under the following mode.

7.1 RX mode

Cycle time for operation: Continuity

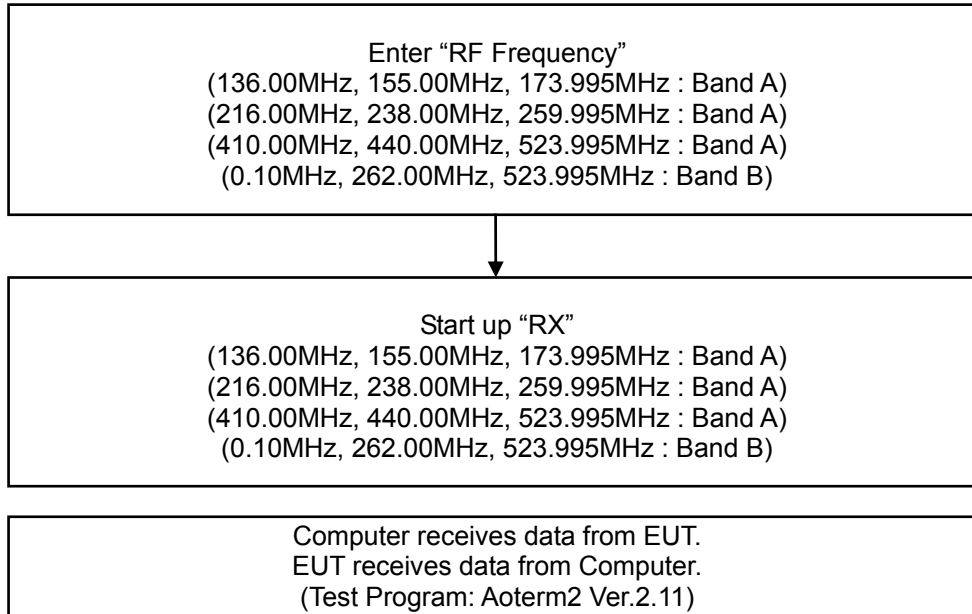

SECTION 8. UNCERTAINTY

Traceability to national standard in SI units is ensured with these values.
 Compliance with the limits in this standard are determined without in consideration of the measurement uncertainty of the measurement instrumentation.

8.1 Emission tests

Radiated disturbance at 3m	U_{lab} [k = 2]	U_{cispr}
30 MHz – 1000 MHz	+/- 4.05 dB	6.3 dB
Above 1 GHz	+/- 4.79 dB	5.2 dB
CISPR22	+/- 4.80 dB	Nil
ANCI 63.4		
Radiated disturbance at 10m		
30 MHz – 1000 MHz	+/- 4.32 dB	6.3 dB
Above 1 GHz	+/- 4.79 dB	Nil
Radiated disturbance at 30m		
	N/A	Nil
Conducted disturbance at mains terminals		
9 kHz – 150 kHz	+/- 1.73 dB	3.8 dB
150 kHz – 30 MHz	+/- 1.85 dB	3.4 dB
Conducted disturbance at telecommunication ports (ISN)		
150 kHz – 30 MHz	+/- 4.77 dB	5.0 dB
Conducted disturbance at telecommunication ports (Capacitive Voltage Probe)		
150 kHz – 30 MHz	+/- 2.92 dB	3.9 dB
Conducted disturbance at telecommunication ports (Current Probe)		
150 kHz – 30 MHz	+/- 1.69 dB	2.9 dB
Conducted disturbance at terminals		
150 kHz – 30 MHz	+/- 1.51 dB	2.9 dB
Disturbance power		
30 MHz – 300 MHz	+/- 1.91 dB	4.5 dB
Conducted power on antenna port		
30 MHz – 1000 MHz	+/- 2.90 dB	Nil
Above 1 GHz	+/- 1.60 dB	
38dB Rejection		
0.1 MHz – 600 MHz	+/- 0.56 dB	Nil

The above expanded instrumentation uncertainty, U_{lab}, is estimated in accordance with CISPR 16-4-2:2011.

SECTION 9. EVALUATION OF TEST RESULTS

9.1 Emission tests

9.1.1 Conducted disturbance at mains terminals

Location	Tochigi No.3 Test Site
Test Engineer	Koichi Wagatsuma

Frequency Range of Measurements

Required Measurement Frequency Range	Measured Frequency Range
0.15 – 30 MHz	0.15 – 30 MHz

Test Procedure

Item	Document number
Conducted disturbance at mains terminals	RJP-EM001

Setting for the Measuring instruments

Instrument	Detector	Resolution Bandwidth	Video Bandwidth
Receiver	Quasi Peak	10 kHz	N/A
	Average	10 kHz	N/A

< Measurement data correction >

Emission Level = Meter Reading + Factor

Margin = Limit- Emission Level

Factor = LISN Factor + Cable Loss + Attenuator

Result of Conducted disturbance at mains terminals
9.1.1.1 RX mode (136.00MHz : Band A)

Intertek Japan K.K.
Tochigi No.3 Test Site

Conducted Voltages on Mains Port

APPLICANT : JVCKENWOOD Corporation
 EUT NAME : 144/220/430MHz TRIBANDER
 MODEL NO. : TH-D74A
 SERIAL NO. : FES2 K-08
 TEST MODE : RX mode(136.00MHz;Band A)
 POWER SOURCE : AC120 V, 60 Hz
 DATE TESTED : Jun 02 2016
 FILE NO. : -
 REGULATION : FCC Part15B Class B
 TEST METHOD : ANSI C63.4-2014
 TEMPERATURE : 24.0 [degC]
 HUMIDITY : 42.0 [%]
 NOTE :

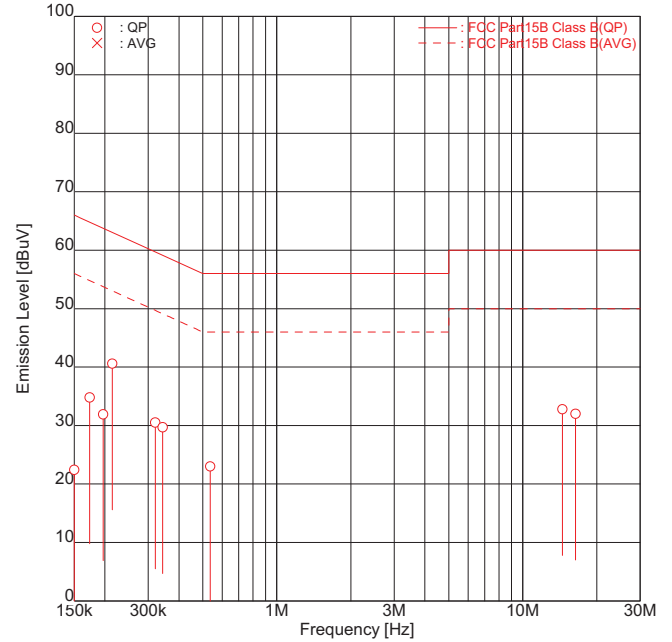

ENGINEER : Koichi Wagatsuma

FREQUENCY [No]	MODE [MHz]		READING [dBuV]		FACTOR [dB]		EMISSION [dBuV]		LIMIT [dBuV]	MARGIN [dB]	
			Line1	Line2	Line1	Line2	Line1	Line2		Line1	Line2
1	0.1500	QP	12.2	11.0	10.2	10.2	22.4	21.2	66.0	43.6	44.8
2	0.1733	QP	<u>24.6</u>	24.6	10.2	10.2	<u>34.8</u>	34.8	64.8	<u>30.0</u>	30.0
3	0.1966	QP	21.5	21.7	10.2	10.2	31.7	31.9	63.8	32.1	31.9
4	0.2145	QP	30.3	<u>30.4</u>	10.2	10.2	40.5	<u>40.6</u>	63.0	22.5	<u>22.4</u>
5	0.3205	QP	6.2	<u>20.3</u>	10.2	10.2	16.4	<u>30.5</u>	59.7	43.3	<u>29.2</u>
6	0.3435	QP	2.5	<u>19.5</u>	10.2	10.2	12.7	<u>29.7</u>	59.1	46.4	<u>29.4</u>
7	0.5363	QP	7.0	12.7	10.3	10.3	17.3	23.0	56.0	38.7	33.0
8	14.4936	QP	<u>21.8</u>	21.2	11.0	11.1	<u>32.8</u>	32.3	60.0	<u>27.2</u>	27.7
9	16.4007	QP	<u>21.0</u>	20.6	11.0	11.1	<u>32.0</u>	31.7	60.0	<u>28.0</u>	28.3

Higher six points are underlined.
 Other frequencies : Below the FCC Part15B Class B limit
 Emission Level = Read + Factor(LISN,Pad,Cable)
 (Factor = Ant. Fact. + Cable Loss - Amp. Gain + Att. - Dist. Conversion Fact.)

emiT 3, 0, 0, 0

Copyright(c)2007 Intertek Japan K.K.

9.1.1.2 RX mode (155.00MHz : Band A)

Intertek Japan K.K.
Tochigi No.3 Test Site
 Conducted Voltages on Mains Port

APPLICANT : JVCKENWOOD Corporation
 EUT NAME : 144/220/430MHz TRIBANDER
 MODEL NO. : TH-D74A
 SERIAL NO. : FES2 K-08
 TEST MODE : RX mode(155.00MHz;Band A)
 POWER SOURCE : AC120 V, 60 Hz
 DATE TESTED : Jun 02 2016
 FILE NO. : -
 REGULATION : FCC Part15B Class B
 TEST METHOD : ANSI C63.4-2014
 TEMPERATURE : 24.0 [degC]
 HUMIDITY : 42.0 [%]
 NOTE :

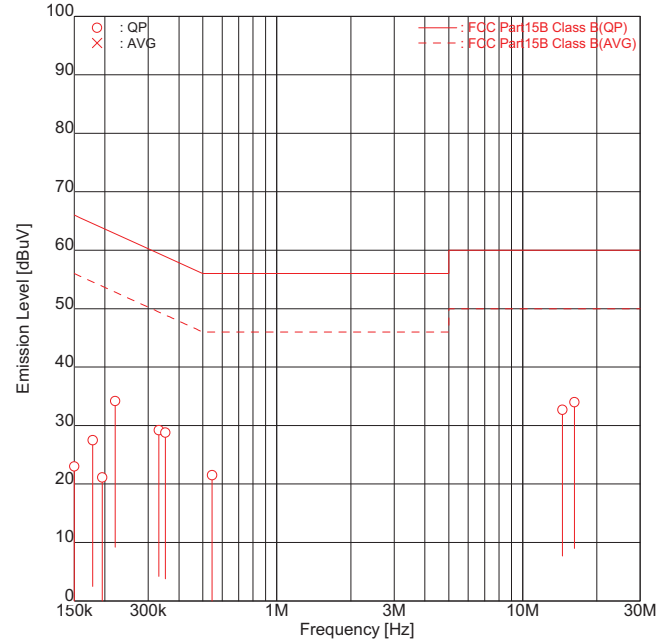

ENGINEER : Koichi Wagatsuma

FREQUENCY [No]	MODE [MHz]		READING [dBuV]		FACTOR [dB]		EMISSION [dBuV]		LIMIT [dBuV]		MARGIN [dB]	
			Line1	Line2	Line1	Line2	Line1	Line2	Line1	Line2	Line1	Line2
1	0.1500	QP	12.5	12.8	10.2	10.2	22.7	23.0	66.0	43.3	43.0	
2	0.1784	QP	17.2	17.3	10.2	10.2	27.4	27.5	64.6	37.2	37.1	
3	0.1952	QP	10.9	10.9	10.2	10.2	21.1	21.1	63.8	42.7	42.7	
4	0.2200	QP	23.0	<u>24.0</u>	10.2	10.2	33.2	<u>34.2</u>	62.8	29.6	<u>28.6</u>	
5	0.3313	QP	5.1	<u>19.0</u>	10.2	10.2	15.3	<u>29.2</u>	59.4	44.1	<u>30.2</u>	
6	0.3524	QP	2.0	<u>18.6</u>	10.2	10.2	12.2	<u>28.8</u>	58.9	46.7	<u>30.1</u>	
7	0.5456	QP	7.0	<u>11.2</u>	10.3	10.3	17.3	<u>21.5</u>	56.0	38.7	<u>34.5</u>	
8	14.4936	QP	21.6	<u>21.6</u>	11.0	11.1	32.6	<u>32.7</u>	60.0	27.4	<u>27.3</u>	
9	16.2273	QP	<u>23.0</u>	21.0	11.0	11.1	<u>34.0</u>	32.1	60.0	<u>26.0</u>	27.9	

Higher six points are underlined.
 Other frequencies : Below the FCC Part15B Class B limit
 Emission Level = Read + Factor(LISN,Pad,Cable)
 (Factor = Ant. Fact. + Cable Loss - Amp. Gain + Att. - Dist. Conversion Fact.)

emiT 3, 0, 0, 0

Copyright(c)2007 Intertek Japan K.K.

9.1.1.3 RX mode (173.995MHz : Band A)

Intertek Japan K.K.
 Tochigi No.3 Test Site

Conducted Voltages on Mains Port

APPLICANT : JVCKENWOOD Corporation
 EUT NAME : 144/220/430MHz TRIBANDER
 MODEL NO. : TH-D74A
 SERIAL NO. : FES2 K-08
 TEST MODE : RX mode(173.995MHz;Band A)
 POWER SOURCE : AC120 V, 60 Hz
 DATE TESTED : Jun 02 2016
 FILE NO. : -
 REGULATION : FCC Part15B Class B
 TEST METHOD : ANSI C63.4-2014
 TEMPERATURE : 24.0 [degC]
 HUMIDITY : 42.0 [%]
 NOTE :

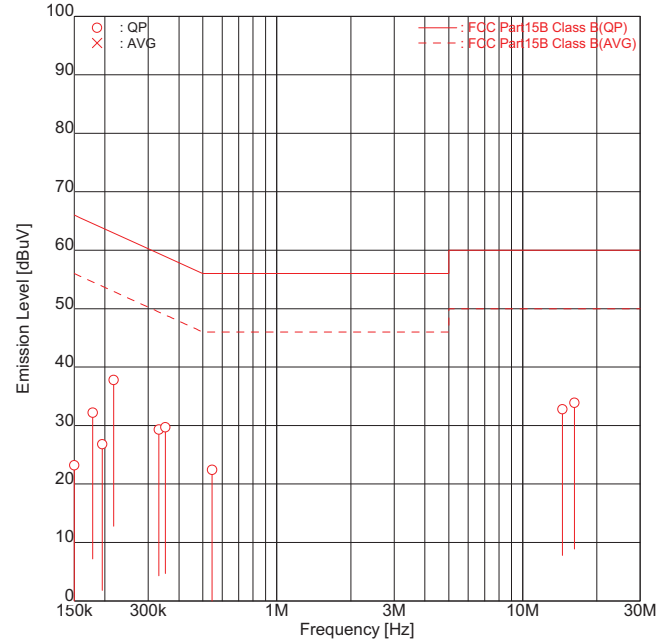

ENGINEER : Koichi Wagatsuma

FREQUENCY [No]	MODE [MHz]		READING [dBuV]		FACTOR [dB]		EMISSION [dBuV]		LIMIT [dBuV]	MARGIN [dB]	
			Line1	Line2	Line1	Line2	Line1	Line2		Line1	Line2
1	0.1500	QP	12.1	13.0	10.2	10.2	22.3	23.2	66.0	43.7	42.8
2	0.1784	QP	21.5	<u>22.0</u>	10.2	10.2	31.7	<u>32.2</u>	64.6	32.9	<u>32.4</u>
3	0.1952	QP	16.6	<u>16.2</u>	10.2	10.2	26.8	<u>26.4</u>	63.8	37.0	<u>37.4</u>
4	0.2171	QP	<u>27.6</u>	26.5	10.2	10.2	<u>37.8</u>	36.7	62.9	<u>25.1</u>	26.2
5	0.3313	QP	5.1	<u>19.1</u>	10.2	10.2	15.3	<u>29.3</u>	59.4	44.1	<u>30.1</u>
6	0.3524	QP	2.0	<u>19.5</u>	10.2	10.2	12.2	<u>29.7</u>	58.9	46.7	<u>29.2</u>
7	0.5456	QP	5.3	12.1	10.3	10.3	15.6	22.4	56.0	40.4	33.6
8	14.4936	QP	21.4	<u>21.7</u>	11.0	11.1	32.4	<u>32.8</u>	60.0	27.6	<u>27.2</u>
9	16.2273	QP	22.8	<u>22.8</u>	11.0	11.1	33.8	<u>33.9</u>	60.0	26.2	<u>26.1</u>

Higher six points are underlined.
 Other frequencies : Below the FCC Part15B Class B limit
 Emission Level = Read + Factor(LISN,Pad,Cable)
 (Factor = Ant. Fact. + Cable Loss - Amp. Gain + Att. - Dist. Conversion Fact.)

emiT 3, 0, 0, 0

Copyright(c)2007 Intertek Japan K.K.

9.1.1.4 RX mode (216.00MHz : Band A)

Intertek Japan K.K.
 Tochigi No.3 Test Site

Conducted Voltages on Mains Port

APPLICANT : JVCKENWOOD Corporation
 EUT NAME : 144/220/430MHz TRIBANDER
 MODEL NO. : TH-D74A
 SERIAL NO. : FES2 K-08
 TEST MODE : RX mode(216.00MHz;Band A)
 POWER SOURCE : AC120 V, 60 Hz
 DATE TESTED : Jun 02 2016
 FILE NO. : -
 REGULATION : FCC Part15B Class B
 TEST METHOD : ANSI C63.4-2014
 TEMPERATURE : 24.0 [degC]
 HUMIDITY : 42.0 [%]
 NOTE :

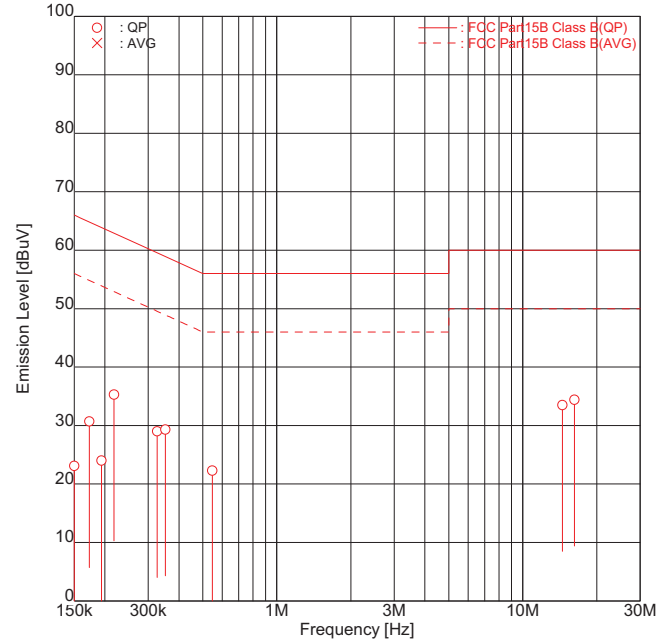

ENGINEER : Koichi Wagatsuma

[No]	FREQUENCY [MHz]	MODE	READING [dBuV]		FACTOR [dB]		EMISSION [dBuV]		LIMIT [dBuV]	MARGIN [dB]	
			Line1	Line2	Line1	Line2	Line1	Line2		Line1	Line2
1	0.1500	QP	12.6	12.9	10.2	10.2	22.8	23.1	66.0	43.2	42.9
2	0.1728	QP	20.5	19.5	10.2	10.2	30.7	29.7	64.8	34.1	35.1
3	0.1938	QP	13.2	13.8	10.2	10.2	23.4	24.0	63.9	40.5	39.9
4	0.2179	QP	23.8	<u>25.1</u>	10.2	10.2	34.0	<u>35.3</u>	62.9	28.9	<u>27.6</u>
5	0.3262	QP	4.5	<u>18.8</u>	10.2	10.2	14.7	<u>29.0</u>	59.5	44.8	<u>30.5</u>
6	0.3524	QP	2.0	<u>19.1</u>	10.2	10.2	12.2	<u>29.3</u>	58.9	46.7	<u>29.6</u>
7	0.5470	QP	6.3	<u>12.0</u>	10.3	10.3	16.6	<u>22.3</u>	56.0	39.4	<u>33.7</u>
8	14.4937	QP	21.5	<u>22.4</u>	11.0	11.1	32.5	<u>33.5</u>	60.0	27.5	<u>26.5</u>
9	16.2260	QP	22.8	<u>23.3</u>	11.0	11.1	33.8	<u>34.4</u>	60.0	26.2	<u>25.6</u>

Higher six points are underlined.
 Other frequencies : Below the FCC Part15B Class B limit
 Emission Level = Read + Factor(LISN,Pad,Cable)
 (Factor = Ant. Fact. + Cable Loss - Amp. Gain + Att. - Dist. Conversion Fact.)

emiT 3, 0, 0, 0

Copyright(c)2007 Intertek Japan K.K.

9.1.1.5 RX mode (238.00MHz : Band A)

Intertek Japan K.K.
Tochigi No.3 Test Site
 Conducted Voltages on Mains Port

APPLICANT : JVCKENWOOD Corporation
 EUT NAME : 144/220/430MHz TRIBANDER
 MODEL NO. : TH-D74A
 SERIAL NO. : FES2 K-08
 TEST MODE : RX mode(238.00MHz;Band A)
 POWER SOURCE : AC120 V, 60 Hz
 DATE TESTED : Jun 02 2016
 FILE NO. : -
 REGULATION : FCC Part15B Class B
 TEST METHOD : ANSI C63.4-2014
 TEMPERATURE : 24.0 [degC]
 HUMIDITY : 42.0 [%]
 NOTE :

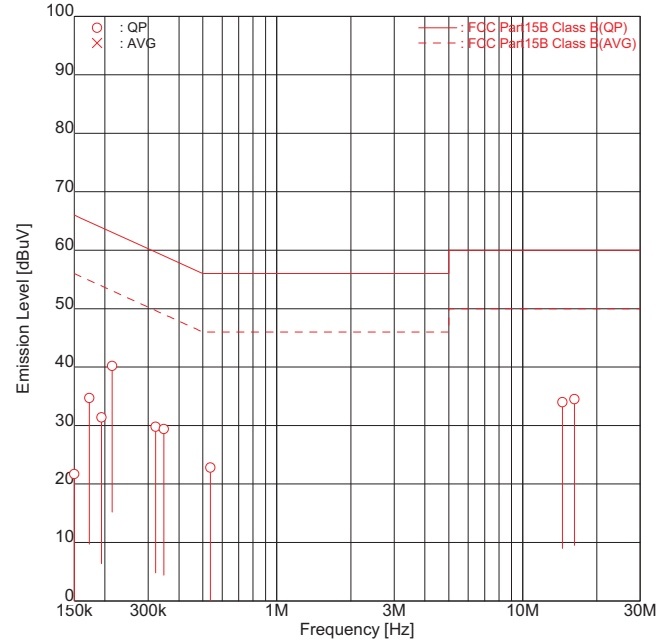

ENGINEER : Koichi Wagatsuma

[No]	FREQUENCY [MHz]	MODE	READING [dBuV]		FACTOR [dB]		EMISSION [dBuV]		LIMIT [dBuV]	MARGIN [dB]	
			Line1	Line2	Line1	Line2	Line1	Line2		Line1	Line2
1	0.1500	QP	11.3	11.5	10.2	10.2	21.5	21.7	66.0	44.5	44.3
2	0.1728	QP	<u>24.5</u>	24.4	10.2	10.2	<u>34.7</u>	34.6	64.8	<u>30.1</u>	30.2
3	0.1938	QP	20.7	21.2	10.2	10.2	30.9	31.4	63.9	33.0	32.5
4	0.2140	QP	<u>30.0</u>	29.7	10.2	10.2	<u>40.2</u>	39.9	63.0	<u>22.8</u>	23.1
5	0.3213	QP	4.5	<u>19.6</u>	10.2	10.2	14.7	<u>29.8</u>	59.7	45.0	<u>29.9</u>
6	0.3473	QP	2.0	<u>19.2</u>	10.2	10.2	12.2	<u>29.4</u>	59.0	46.8	<u>29.6</u>
7	0.5367	QP	6.3	12.5	10.3	10.3	16.6	22.8	56.0	39.4	33.2
8	14.4919	QP	<u>23.0</u>	22.6	11.0	11.1	<u>34.0</u>	33.7	60.0	<u>26.0</u>	26.3
9	16.2260	QP	<u>23.5</u>	23.2	11.0	11.1	<u>34.5</u>	34.3	60.0	<u>25.5</u>	25.7

Higher six points are underlined.
 Other frequencies : Below the FCC Part15B Class B limit
 Emission Level = Read + Factor(LISN,Pad,Cable)
 (Factor = Ant. Fact. + Cable Loss - Amp. Gain + Att. - Dist. Conversion Fact.)

emiT 3, 0, 0, 0

Copyright(c)2007 Intertek Japan K.K.

9.1.1.6 RX mode (259.995MHz : Band A)

Intertek Japan K.K.
 Tochigi No.3 Test Site

Conducted Voltages on Mains Port

APPLICANT : JVCKENWOOD Corporation
 EUT NAME : 144/220/430MHz TRIBANDER
 MODEL NO. : TH-D74A
 SERIAL NO. : FES2 K-08
 TEST MODE : RX mode(259.995MHz;Band A)
 POWER SOURCE : AC120 V, 60 Hz
 DATE TESTED : Jun 02 2016
 FILE NO. : -
 REGULATION : FCC Part15B Class B
 TEST METHOD : ANSI C63.4-2014
 TEMPERATURE : 24.0 [degC]
 HUMIDITY : 42.0 [%]
 NOTE :

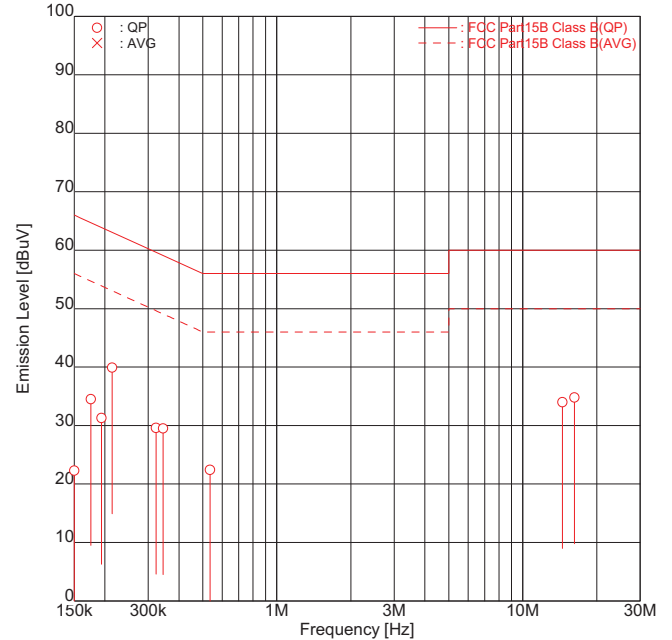

ENGINEER : Koichi Wagatsuma

FREQUENCY [No]	MODE [MHz]		READING [dBuV]		FACTOR [dB]		EMISSION [dBuV]		LIMIT [dBuV]		MARGIN [dB]	
			Line1	Line2	Line1	Line2	Line1	Line2	Line1	Line2		
1	0.1500	QP	11.0	12.1	10.2	10.2	21.2	22.3	66.0	66.0	44.8	43.7
2	0.1753	QP	<u>24.3</u>	24.3	10.2	10.2	<u>34.5</u>	34.5	64.7	64.7	<u>30.2</u>	30.2
3	0.1938	QP	20.5	21.1	10.2	10.2	30.7	31.3	63.9	63.9	33.2	32.6
4	0.2140	QP	<u>29.7</u>	29.7	10.2	10.2	<u>39.9</u>	39.9	63.0	63.0	<u>23.1</u>	23.1
5	0.3226	QP	3.5	<u>19.4</u>	10.2	10.2	13.7	<u>29.6</u>	59.6	59.6	45.9	<u>30.0</u>
6	0.3448	QP	2.0	<u>19.3</u>	10.2	10.2	12.2	<u>29.5</u>	59.1	59.1	46.9	<u>29.6</u>
7	0.5347	QP	6.0	12.1	10.3	10.3	16.3	22.4	56.0	56.0	39.7	33.6
8	14.4906	QP	<u>23.0</u>	22.8	11.0	11.1	<u>34.0</u>	33.9	60.0	60.0	<u>26.0</u>	26.1
9	16.2273	QP	<u>23.8</u>	23.4	11.0	11.1	<u>34.8</u>	34.5	60.0	60.0	<u>25.2</u>	25.5

Higher six points are underlined.
 Other frequencies : Below the FCC Part15B Class B limit
 Emission Level = Read + Factor(LISN,Pad,Cable)
 (Factor = Ant. Fact. + Cable Loss - Amp. Gain + Att. - Dist. Conversion Fact.)

emiT 3, 0, 0, 0

Copyright(c)2007 Intertek Japan K.K.

9.1.1.7 RX mode (410.00MHz : Band A)

Intertek Japan K.K.
 Tochigi No.3 Test Site

Conducted Voltages on Mains Port

APPLICANT : JVCKENWOOD Corporation
 EUT NAME : 144/220/430MHz TRIBANDER
 MODEL NO. : TH-D74A
 SERIAL NO. : FES2 K-08
 TEST MODE : RX mode(410.00MHz;Band A)
 POWER SOURCE : AC120 V, 60 Hz
 DATE TESTED : Jun 02 2016
 FILE NO. : -
 REGULATION : FCC Part15B Class B
 TEST METHOD : ANSI C63.4-2014
 TEMPERATURE : 24.0 [degC]
 HUMIDITY : 42.0 [%]
 NOTE :

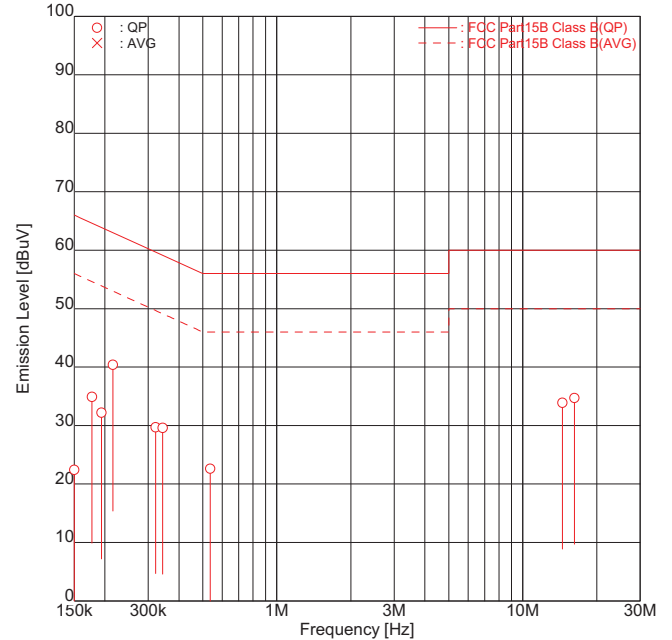

ENGINEER : Koichi Wagatsuma

FREQUENCY [No]	MODE [MHz]		READING [dBuV]		FACTOR [dB]		EMISSION [dBuV]		LIMIT [dBuV]	MARGIN [dB]	
			Line1	Line2	Line1	Line2	Line1	Line2		Line1	Line2
1	0.1500	QP	12.2	12.0	10.2	10.2	22.4	22.2	66.0	43.6	43.8
2	0.1772	QP	24.6	<u>24.7</u>	10.2	10.2	34.8	<u>34.9</u>	64.6	29.8	<u>29.7</u>
3	0.1938	QP	21.5	<u>22.0</u>	10.2	10.2	31.7	<u>32.2</u>	63.9	32.2	<u>31.7</u>
4	0.2153	QP	<u>30.2</u>	30.2	10.2	10.2	<u>40.4</u>	40.4	63.0	<u>22.6</u>	22.6
5	0.3213	QP	3.5	<u>19.5</u>	10.2	10.2	13.7	<u>29.7</u>	59.7	46.0	<u>30.0</u>
6	0.3435	QP	2.0	<u>19.4</u>	10.2	10.2	12.2	<u>29.6</u>	59.1	46.9	<u>29.5</u>
7	0.5360	QP	6.3	12.3	10.3	10.3	16.6	22.6	56.0	39.4	33.4
8	14.4906	QP	22.7	<u>22.8</u>	11.0	11.1	33.7	<u>33.9</u>	60.0	26.3	<u>26.1</u>
9	16.2286	QP	<u>23.7</u>	23.5	11.0	11.1	<u>34.7</u>	34.6	60.0	<u>25.3</u>	25.4

Higher six points are underlined.
 Other frequencies : Below the FCC Part15B Class B limit
 Emission Level = Read + Factor(LISN,Pad,Cable)
 (Factor = Ant. Fact. + Cable Loss - Amp. Gain + Att. - Dist. Conversion Fact.)

emiT 3, 0, 0, 0

Copyright(c)2007 Intertek Japan K.K.

9.1.1.8 RX mode (440.00MHz : Band A)

Intertek Japan K.K.
 Tochigi No.3 Test Site

Conducted Voltages on Mains Port

APPLICANT : JVCKENWOOD Corporation
 EUT NAME : 144/220/430MHz TRIBANDER
 MODEL NO. : TH-D74A
 SERIAL NO. : FES2 K-08
 TEST MODE : RX mode(440.00MHz;Band A)
 POWER SOURCE : AC120 V, 60 Hz
 DATE TESTED : Jun 02 2016
 FILE NO. : -
 REGULATION : FCC Part15B Class B
 TEST METHOD : ANSI C63.4-2014
 TEMPERATURE : 24.0 [degC]
 HUMIDITY : 42.0 [%]
 NOTE :

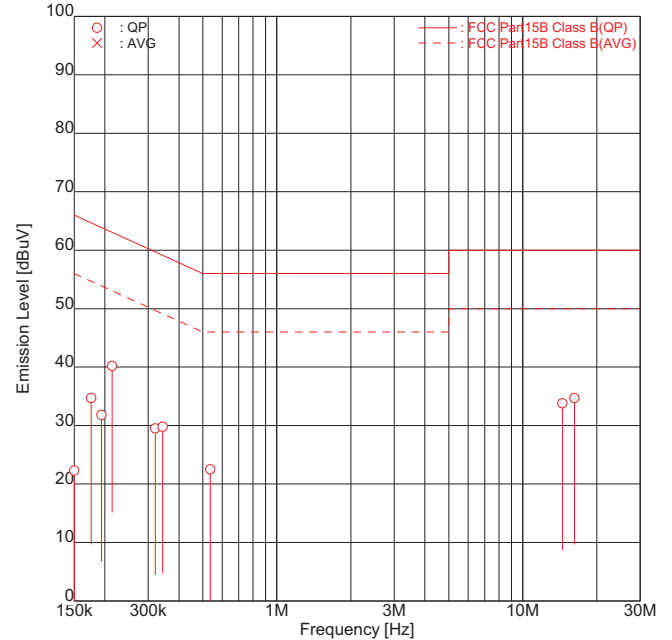

ENGINEER : Koichi Wagatsuma

FREQUENCY [No]	MODE [MHz]		READING [dBuV]		FACTOR [dB]		EMISSION [dBuV]		LIMIT [dBuV]	MARGIN [dB]	
			Line1	Line2	Line1	Line2	Line1	Line2		Line1	Line2
1	0.1500	QP	12.1	12.0	10.2	10.2	22.3	22.2	66.0	43.7	43.8
2	0.1759	QP	24.2	<u>24.5</u>	10.2	10.2	34.4	<u>34.7</u>	64.7	30.3	<u>30.0</u>
3	0.1938	QP	21.0	<u>21.6</u>	10.2	10.2	31.2	<u>31.8</u>	63.9	32.7	<u>32.1</u>
4	0.2140	QP	<u>30.0</u>	29.8	10.2	10.2	<u>40.2</u>	40.0	63.0	<u>22.8</u>	23.0
5	0.3203	QP	3.5	<u>19.3</u>	10.2	10.2	13.7	<u>29.5</u>	59.7	46.0	<u>30.2</u>
6	0.3435	QP	2.0	<u>19.6</u>	10.2	10.2	12.2	<u>29.8</u>	59.1	46.9	<u>29.3</u>
7	0.5360	QP	6.3	<u>12.2</u>	10.3	10.3	16.6	<u>22.5</u>	56.0	39.4	<u>33.5</u>
8	14.4906	QP	22.5	<u>22.7</u>	11.0	11.1	33.5	<u>33.8</u>	60.0	26.5	<u>26.2</u>
9	16.2286	QP	<u>23.7</u>	23.6	11.0	11.1	<u>34.7</u>	34.7	60.0	<u>25.3</u>	25.3

Higher six points are underlined.
 Other frequencies : Below the FCC Part15B Class B limit
 Emission Level = Read + Factor(LISN,Pad,Cable)
 (Factor = Ant. Fact. + Cable Loss - Amp. Gain + Att. - Dist. Conversion Fact.)

emiT 3, 0, 0, 0

Copyright(c)2007 Intertek Japan K.K.

9.1.1.9 RX mode (469.995MHz : Band A)

Intertek Japan K.K.
 Tochigi No.3 Test Site

Conducted Voltages on Mains Port

APPLICANT : JVCKENWOOD Corporation
 EUT NAME : 144/220/430MHz TRIBANDER
 MODEL NO. : TH-D74A
 SERIAL NO. : FES2 K-08
 TEST MODE : RX mode(469.995MHz;Band A)
 POWER SOURCE : AC120 V, 60 Hz
 DATE TESTED : Jun 02 2016
 FILE NO. : -
 REGULATION : FCC Part15B Class B
 TEST METHOD : ANSI C63.4-2014
 TEMPERATURE : 24.0 [degC]
 HUMIDITY : 42.0 [%]
 NOTE :

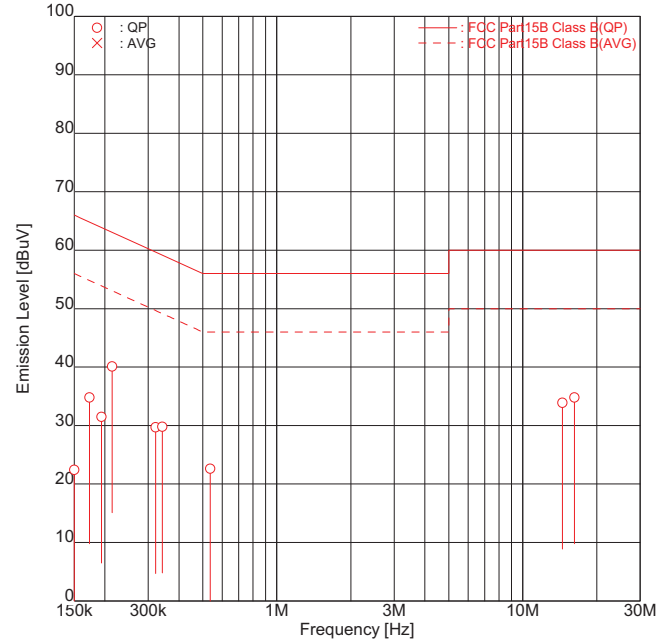

ENGINEER : Koichi Wagatsuma

FREQUENCY [No]	MODE [MHz]	MODE	READING [dBuV]		FACTOR [dB]		EMISSION [dBuV]		LIMIT [dBuV]	MARGIN [dB]	
			Line1	Line2	Line1	Line2	Line1	Line2		Line1	Line2
1	0.1500	QP	12.2	12.0	10.2	10.2	22.4	22.2	66.0	43.6	43.8
2	0.1732	QP	<u>24.6</u>	24.5	10.2	10.2	<u>34.8</u>	34.7	64.8	<u>30.0</u>	30.1
3	0.1938	QP	21.0	21.3	10.2	10.2	31.2	31.5	63.9	32.7	32.4
4	0.2140	QP	29.7	<u>29.9</u>	10.2	10.2	39.9	<u>40.1</u>	63.0	23.1	<u>22.9</u>
5	0.3217	QP	3.5	<u>19.5</u>	10.2	10.2	13.7	<u>29.7</u>	59.7	46.0	<u>30.0</u>
6	0.3422	QP	2.0	<u>19.6</u>	10.2	10.2	12.2	<u>29.8</u>	59.1	46.9	<u>29.3</u>
7	0.5362	QP	6.3	12.3	10.3	10.3	16.6	22.6	56.0	39.4	33.4
8	14.4893	QP	22.8	<u>22.8</u>	11.0	11.1	33.8	<u>33.9</u>	60.0	26.2	<u>26.1</u>
9	16.2286	QP	<u>23.8</u>	23.6	11.0	11.1	<u>34.8</u>	34.7	60.0	<u>25.2</u>	25.3

Higher six points are underlined.
 Other frequencies : Below the FCC Part15B Class B limit
 Emission Level = Read + Factor(LISN,Pad,Cable)
 (Factor = Ant. Fact. + Cable Loss - Amp. Gain + Att. - Dist. Conversion Fact.)

emiT 3, 0, 0, 0

Copyright(c)2007 Intertek Japan K.K.

9.1.1.10 RX mode (0.10MHz : Band B)

Intertek Japan K.K.

Tochigi No.3 Test Site

Conducted Voltages on Mains Port

APPLICANT : JVCKENWOOD Corporation
 EUT NAME : 144/220/430MHz TRIBANDER
 MODEL NO. : TH-D74A
 SERIAL NO. : FES2 K-08
 TEST MODE : RX mode(0.100MHz;Band B)
 POWER SOURCE : AC120 V, 60 Hz
 DATE TESTED : Jun 02 2016
 FILE NO. : -
 REGULATION : FCC Part15B Class B
 TEST METHOD : ANSI C63.4-2014
 TEMPERATURE : 24.0 [degC]
 HUMIDITY : 42.0 [%]
 NOTE :

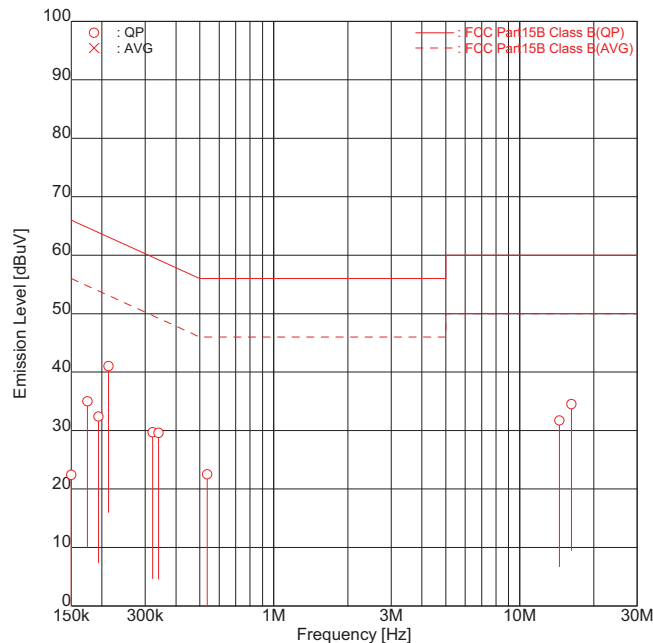

ENGINEER : Koichi Wagatsuma

FREQUENCY [No]	MODE [MHz]		READING [dBuV]		FACTOR [dB]		EMISSION [dBuV]		LIMIT [dBuV]	MARGIN [dB]	
			Line1	Line2	Line1	Line2	Line1	Line2		Line1	Line2
1	0.1500	QP	12.1	12.2	10.2	10.2	22.3	22.4	66.0	43.7	43.6
2	0.1745	QP	<u>24.8</u>	24.7	10.2	10.2	<u>35.0</u>	34.9	64.7	<u>29.7</u>	29.8
3	0.1938	QP	<u>22.2</u>	22.2	10.2	10.2	<u>32.4</u>	32.4	63.9	31.5	31.5
4	0.2127	QP	<u>30.8</u>	30.5	10.2	10.2	<u>41.0</u>	40.7	63.1	<u>22.1</u>	22.4
5	0.3217	QP	3.5	<u>19.5</u>	10.2	10.2	13.7	<u>29.7</u>	59.7	46.0	<u>30.0</u>
6	0.3396	QP	2.0	<u>19.4</u>	10.2	10.2	12.2	<u>29.6</u>	59.2	47.0	<u>29.6</u>
7	0.5362	QP	6.3	12.2	10.3	10.3	16.6	22.5	56.0	39.4	33.5
8	14.4893	QP	<u>20.7</u>	20.5	11.0	11.1	<u>31.7</u>	31.6	60.0	<u>28.3</u>	28.4
9	16.2261	QP	23.3	<u>23.4</u>	11.0	11.1	34.3	<u>34.5</u>	60.0	25.7	<u>25.5</u>

Higher six points are underlined.
 Other frequencies : Below the FCC Part15B Class B limit
 Emission Level = Read + Factor(LISN,Pad,Cable)
 (Factor = Ant. Fact. + Cable Loss - Amp. Gain + Att. - Dist. Conversion Fact.)

emiT 3, 0, 0, 0

Copyright(c)2007 Intertek Japan K.K.

9.1.1.11 RX mode (262.00MHz : Band B)

Intertek Japan K.K.
 Tochigi No.3 Test Site

Conducted Voltages on Mains Port

APPLICANT : JVCKENWOOD Corporation
 EUT NAME : 144/220/430MHz TRIBANDER
 MODEL NO. : TH-D74A
 SERIAL NO. : FES2 K-08
 TEST MODE : RX mode(262.00MHz;Band B)
 POWER SOURCE : AC120 V, 60 Hz
 DATE TESTED : Jun 02 2016
 FILE NO. : -
 REGULATION : FCC Part15B Class B
 TEST METHOD : ANSI C63.4-2014
 TEMPERATURE : 24.0 [degC]
 HUMIDITY : 42.0 [%]
 NOTE :

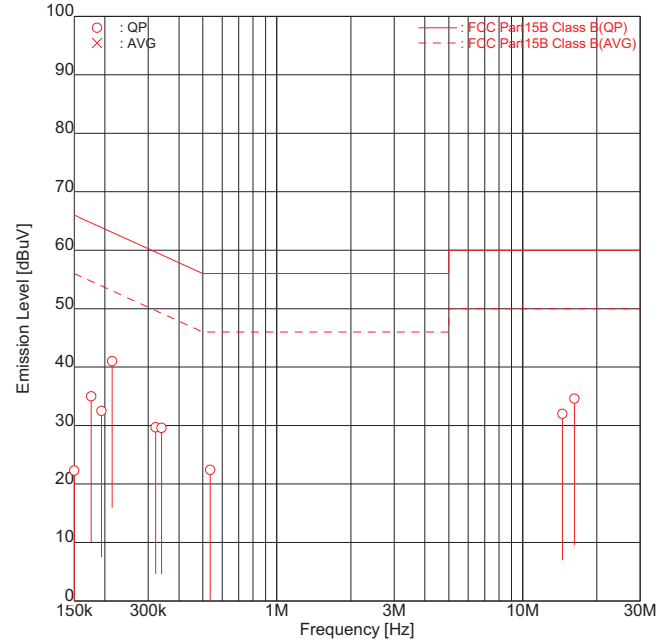

ENGINEER : Koichi Wagatsuma

FREQUENCY [No]	MODE [MHz]	READING [dBuV]		FACTOR [dB]		EMISSION [dBuV]		LIMIT [dBuV]	MARGIN [dB]		
		Line1	Line2	Line1	Line2	Line1	Line2		Line1	Line2	
1	0.1500	QP	12.1	12.0	10.2	10.2	22.3	22.2	66.0	43.7	43.8
2	0.1758	QP	24.6	<u>24.8</u>	10.2	10.2	34.8	<u>35.0</u>	64.7	29.9	<u>29.7</u>
3	0.1938	QP	22.2	<u>22.3</u>	10.2	10.2	32.4	<u>32.5</u>	63.9	31.5	<u>31.4</u>
4	0.2140	QP	<u>30.8</u>	30.5	10.2	10.2	<u>41.0</u>	40.7	63.0	<u>22.0</u>	22.3
5	0.3217	QP	3.5	<u>19.5</u>	10.2	10.2	13.7	<u>29.7</u>	59.7	46.0	<u>30.0</u>
6	0.3396	QP	2.6	<u>19.4</u>	10.2	10.2	12.8	<u>29.6</u>	59.2	46.4	<u>29.6</u>
7	0.5363	QP	6.3	12.1	10.3	10.3	16.6	22.4	56.0	39.4	33.6
8	14.4893	QP	<u>21.0</u>	20.4	11.0	11.1	<u>32.0</u>	31.5	60.0	<u>28.0</u>	28.5
9	16.2299	QP	22.5	<u>23.5</u>	11.0	11.1	33.5	<u>34.6</u>	60.0	26.5	<u>25.4</u>

Higher six points are underlined.
 Other frequencies : Below the FCC Part15B Class B limit
 Emission Level = Read + Factor(LISN,Pad,Cable)
 (Factor = Ant. Fact. + Cable Loss - Amp. Gain + Att. - Dist. Conversion Fact.)

emiT 3, 0, 0, 0

Copyright(c)2007 Intertek Japan K.K.

9.1.1.12 RX mode (523.995MHz : Band B)

Intertek Japan K.K.
 Tochigi No.3 Test Site

Conducted Voltages on Mains Port

APPLICANT : JVCKENWOOD Corporation
 EUT NAME : 144/220/430MHz TRIBANDER
 MODEL NO. : TH-D74A
 SERIAL NO. : FES2 K-08
 TEST MODE : RX mode(523.995MHz;Band B)
 POWER SOURCE : AC120 V, 60 Hz
 DATE TESTED : Jun 02 2016
 FILE NO. : -
 REGULATION : FCC Part15B Class B
 TEST METHOD : ANSI C63.4-2014
 TEMPERATURE : 24.0 [degC]
 HUMIDITY : 42.0 [%]
 NOTE :

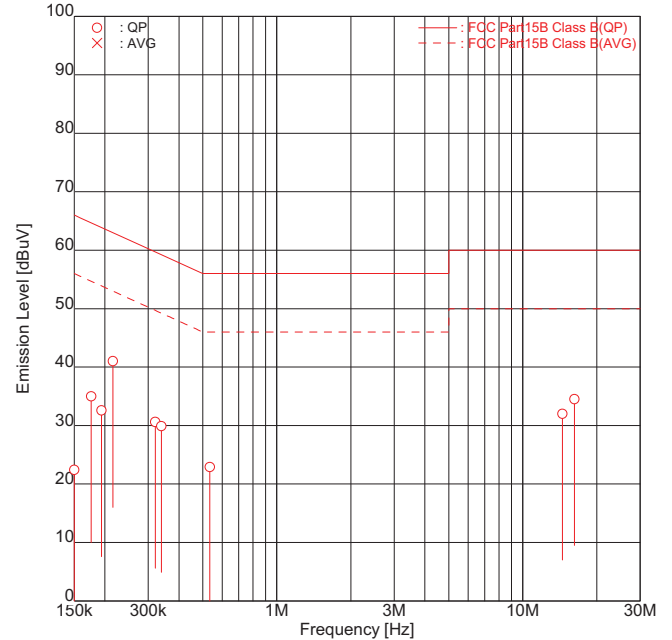

ENGINEER : Koichi Wagatsuma

[No]	FREQUENCY [MHz]	MODE	READING [dBuV]		FACTOR [dB]		EMISSION [dBuV]		LIMIT [dBuV]		MARGIN [dB]	
			Line1	Line2	Line1	Line2	Line1	Line2	Line1	Line2	Line1	Line2
1	0.1500	QP	12.1	12.2	10.2	10.2	22.3	22.4	66.0	43.7	43.6	
2	0.1758	QP	<u>24.8</u>	24.8	10.2	10.2	<u>35.0</u>	35.0	64.7	<u>29.7</u>	29.7	
3	0.1938	QP	<u>22.0</u>	22.4	10.2	10.2	<u>32.2</u>	32.6	63.9	31.7	31.3	
4	0.2153	QP	<u>30.8</u>	30.7	10.2	10.2	<u>41.0</u>	40.9	63.0	<u>22.0</u>	22.1	
5	0.3204	QP	6.3	<u>20.4</u>	10.2	10.2	16.5	<u>30.6</u>	59.7	43.2	<u>29.1</u>	
6	0.3394	QP	2.6	<u>19.7</u>	10.2	10.2	12.8	<u>29.9</u>	59.2	46.4	<u>29.3</u>	
7	0.5337	QP	6.9	12.6	10.3	10.3	17.2	22.9	56.0	38.8	33.1	
8	14.4931	QP	<u>21.0</u>	20.0	11.0	11.1	<u>32.0</u>	31.1	60.0	<u>28.0</u>	28.9	
9	16.2274	QP	23.0	<u>23.4</u>	11.0	11.1	34.0	<u>34.5</u>	60.0	26.0	<u>25.5</u>	

Higher six points are underlined.

Other frequencies : Below the FCC Part15B Class B limit

Emission Level = Read + Factor(LISN,Pad,Cable)

(Factor = Ant. Fact. + Cable Loss - Amp. Gain + Att. - Dist. Conversion Fact.)

emiT 3, 0, 0, 0

Copyright(c)2007 Intertek Japan K.K.

9.1.2 Radiated disturbance

Location	Tochigi No.1 and No.3 Test Site
Test Engineer	Koichi Wagatsuma

Frequency Range of Measurements

Operating mode	Required Frequency Range	Measured Frequency Range
RX mode(136.00MHz : Band A) RX mode(155.00MHz : Band A) RX mode(173.995MHz : Band A) RX mode(216.00MHz : Band A) RX mode(238.00MHz : Band A) RX mode(259.995MHz : Band A) RX mode(410.00MHz : Band A) RX mode(440.00MHz : Band A) RX mode(469.995MHz : Band A) RX mode(0.10MHz : Band B) RX mode(262.00MHz : Band B) RX mode(523.995MHz : Band B)	30 – 25000 MHz	30 – 25000 MHz

Test Procedure

Item	Document number
Radiated disturbance	RJP-EM003

Setting for the Measuring instruments

Frequency [MHz]	Instrument	Detector	Resolution Bandwidth	Video Bandwidth
30 – 1000	Receiver	Quasi Peak	120 kHz	N/A
Above 1000	Spectrum Analyzer	Peak	1 MHz	1 MHz
		Average	1 MHz	10 Hz

< Measurement data correction >

Emission Level = Meter Reading + Factor

Margin = Limit - Emission Level

Factor = Antenna Factor + Cable Loss - Amplifier Gain + Attenuator (+ Distance Conversion Factor)*

* For other than Standard distance:

Distance Conversion Factor = 20 log (Measurement distance / Standard distance)

Operating Condition	Frequency Range	Measurement distance
RX mode(136.00MHz : Band A)	30-1000 MHz	3 m
RX mode(155.00MHz : Band A)	Above 1 GHz	3.73 m
RX mode(173.995MHz : Band A)		
RX mode(216.00MHz : Band A)		
RX mode(238.00MHz : Band A)		
RX mode(259.995MHz : Band A)		
RX mode(410.00MHz : Band A)		
RX mode(440.00MHz : Band A)		
RX mode(469.995MHz : Band A)		
RX mode(0.10MHz : Band B)		
RX mode(262.00MHz : Band B)		
RX mode(523.995MHz : Band B)		

Absorber placement and Receive Antenna location in Radiated disturbance above 1 GHz

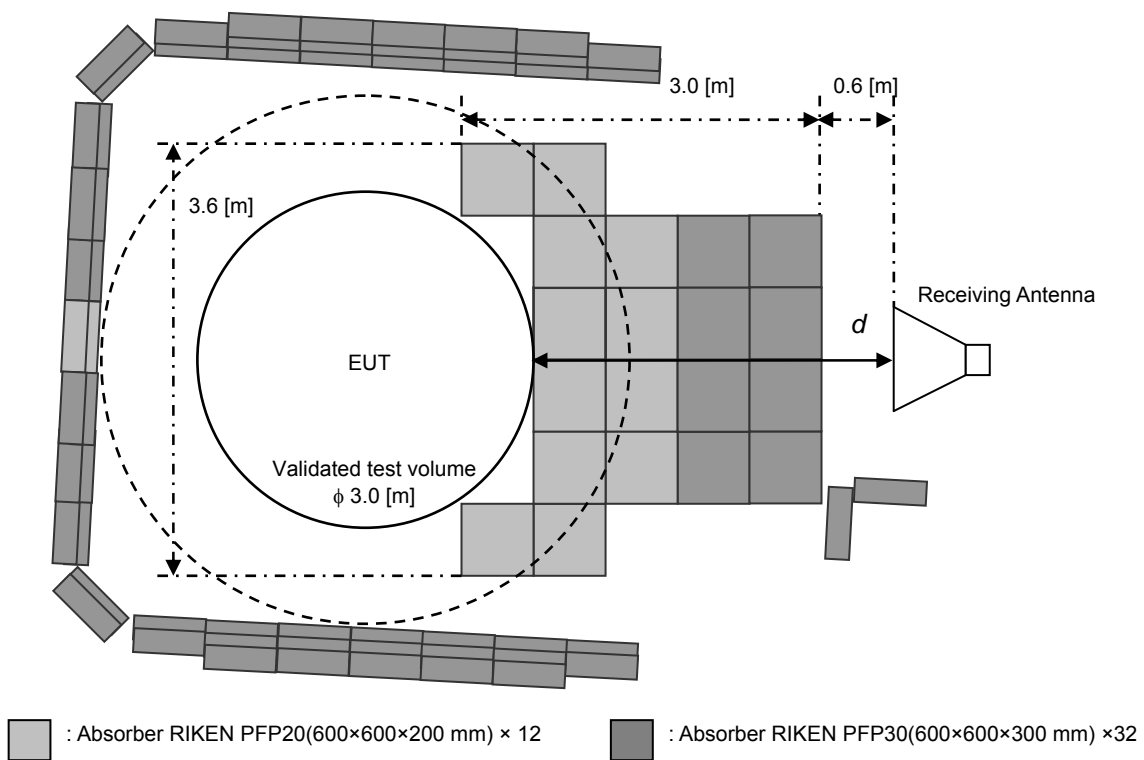

Result of Radiated disturbances
9.1.2.1 RX mode(136.00MHz : Band A)
30 – 1000 MHz

Intertek Japan K.K.

Tochigi No.3 Test Site

Radiated Electric Field

APPLICANT : JVCKENWOOD Corporation
 EUT NAME : 144/220/430MHz TRIBANDER
 MODEL NO. : TH-D74A
 SERIAL NO. : FES2 K-08
 TEST MODE : RX mode(136.00MHz;Band A)
 POWER SOURCE : DC13.8V(AC120 V, 60 Hz)
 DATE TESTED : May 30 2016
 FILE NO. : -
 REGULATION : FCC Part15B Class B
 TEST METHOD : ANSI C63.4-2014
 DISTANCE : 3.00 [m]
 TEMPERATURE : 22.0 [degC]
 HUMIDITY : 60.0 [%]
 NOTE :

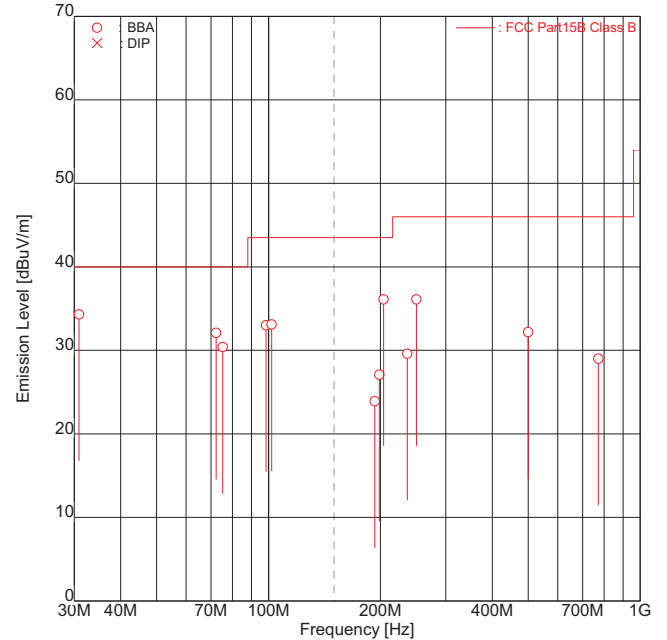

ENGINEER : Koichi Wagatsuma

FREQUENCY [No]	ANT. [MHz]	ANT.	READING [dBuV]		FACTOR [dB/m]		EMISSION [dBuV/m]		LIMIT [dBuV/m]		MARGIN [dB]	
			Hori	Vert	Hori	Vert	Hori	Vert	Hori	Vert		
1	30.90	BBA	-	<u>41.5</u>	-7.2	-7.2	-	<u>34.3</u>	40.0	-	-	<u>5.7</u>
2	72.28	BBA	<u>39.5</u>	-	-7.4	-7.4	<u>32.1</u>	-	40.0	-	-	<u>7.9</u>
3	75.30	BBA	<u>38.4</u>	-	-8.0	-8.0	<u>30.4</u>	-	40.0	-	-	<u>9.6</u>
4	98.47	BBA	-	42.5	-9.5	-9.5	-	33.0	43.5	-	-	10.5
5	101.91	BBA	-	<u>42.2</u>	-9.1	-9.1	-	<u>33.1</u>	43.5	-	-	<u>10.4</u>
6	193.15	BBA	-	30.5	-6.6	-6.6	-	23.9	43.5	-	-	19.6
7	198.78	BBA	34.2	-	-7.1	-7.1	27.1	-	43.5	16.4	-	-
8	204.03	BBA	<u>43.0</u>	40.0	-6.9	-6.9	<u>36.1</u>	33.1	43.5	<u>7.4</u>	10.4	-
9	236.25	BBA	35.0	-	-5.4	-5.4	29.6	-	46.0	16.4	-	-
10	250.00	BBA	38.0	<u>41.0</u>	-4.9	-4.9	33.1	<u>36.1</u>	46.0	12.9	-	<u>9.9</u>
11	500.00	BBA	28.8	-	3.4	3.4	32.2	-	46.0	13.8	-	-
12	772.60	BBA	-	19.5	9.5	9.5	-	29.0	46.0	-	-	17.0

Higher six points are underlined.
 Other frequencies : Below the FCC Part15B Class B limit
 Emission Level = Read + Factor(Antenna,Antenna Pad,Cable,Preamp)
 ANT. : Used antenna(BBA = Broadband antenna, DIP = Dipole antenna)
 (Factor = Ant. Fact. + Cable Loss - Amp. Gain + Att. - Dist. Conversion Fact.)

emiT 3, 0, 0, 0

Copyright(c)2007 Intertek Japan K.K.

1000 – 25000 MHz

Intertek Japan K.K.

Tochigi No.1 Test Site

Radiated Electric Field

APPLICANT : JVCKENWOOD Corporation
 EUT NAME : 144/220/430MHz TRIBANDER
 MODEL NO. : TH-D74A
 SERIAL NO. : FES2 K-08
 TEST MODE : RX mode(136.00MHz: Band A)
 POWER SOURCE : DC 13.8V (AC120 V, 60 Hz)
 DATE TESTED : Jun 07 2016
 FILE NO. : -
 REGULATION : FCC Part15B Class B
 TEST METHOD : ANSI C63.4-2014
 DISTANCE : 3.73 [m]
 TEMPERATURE : 24.0 [degC]
 HUMIDITY : 46.0 [%]
 NOTE :

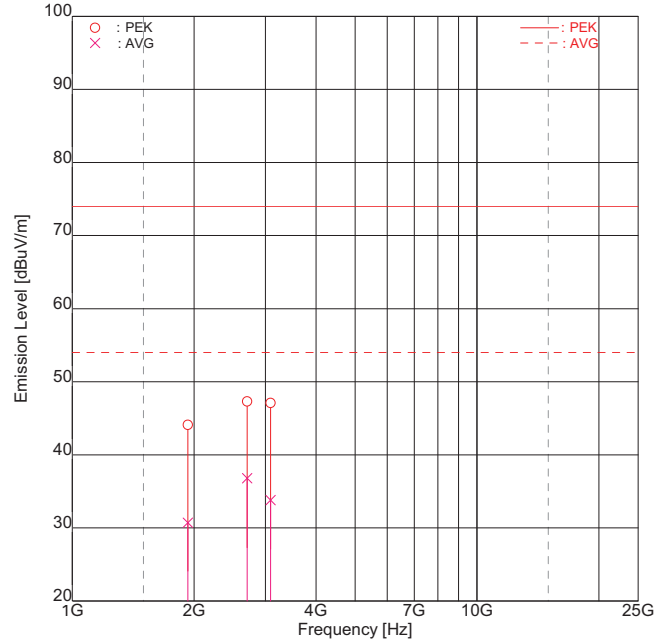

ENGINEER : Koichi Wagatuma

FREQUENCY [No]	MODE [MHz]		READING [dBuV]		FACTOR [dB]		EMISSION [dBuV/m]		LIMIT [dBuV/m]		MARGIN [dB]	
			Hori	Vert	Hori	Vert	Hori	Vert	Hori	Vert	Hori	Vert
1	1931.50	PEK	37.7	<u>38.6</u>	5.5	5.5	43.2	<u>44.1</u>	74.0	74.0	30.8	<u>29.9</u>
2	1931.50	AVG	<u>25.2</u>	24.3	5.5	5.5	<u>30.7</u>	29.8	54.0	54.0	<u>23.3</u>	24.2
3	2704.12	PEK	<u>39.3</u>	37.8	8.0	8.0	<u>47.3</u>	45.8	74.0	74.0	<u>26.7</u>	28.2
4	2704.12	AVG	<u>28.8</u>	24.9	8.0	8.0	<u>36.8</u>	32.9	54.0	54.0	<u>17.2</u>	21.1
5	3090.00	PEK	35.4	<u>37.9</u>	9.2	9.2	44.6	<u>47.1</u>	74.0	74.0	29.4	<u>26.9</u>
6	3090.00	AVG	24.5	<u>24.6</u>	9.2	9.2	33.7	<u>33.8</u>	54.0	54.0	20.3	<u>20.2</u>

Higher six points are underlined.
 Emission Level = Read + Factor(Antenna, Antenna Pad, Cable, Preamp)
 ANT. : Used antenna(BBA = Broadband antenna, DIP = Dipole antenna)
 (Factor = Ant.Fact. + Cable Loss - Amp.Gain + Att. - Dist.Conversion Fact.)

**9.1.2.2 RX mode(155.00MHz : Band A)
 30 – 1000 MHz**

**Intertek Japan K.K.
 Tochigi No.3 Test Site
 Radiated Electric Field**

APPLICANT : JVCKENWOOD Corporation
 EUT NAME : 144/220/430MHz TRIBANDER
 MODEL NO. : TH-D74A
 SERIAL NO. : FES2 K-08
 TEST MODE : RX mode(155.00MHz;Band A)
 POWER SOURCE : DC13.8V(AC120 V, 60 Hz)
 DATE TESTED : May 30 2016
 FILE NO. : -
 REGULATION : FCC Part15B Class B
 TEST METHOD : ANSI C63.4-2014
 DISTANCE : 3.00 [m]
 TEMPERATURE : 22.0 [degC]
 HUMIDITY : 60.0 [%]
 NOTE :

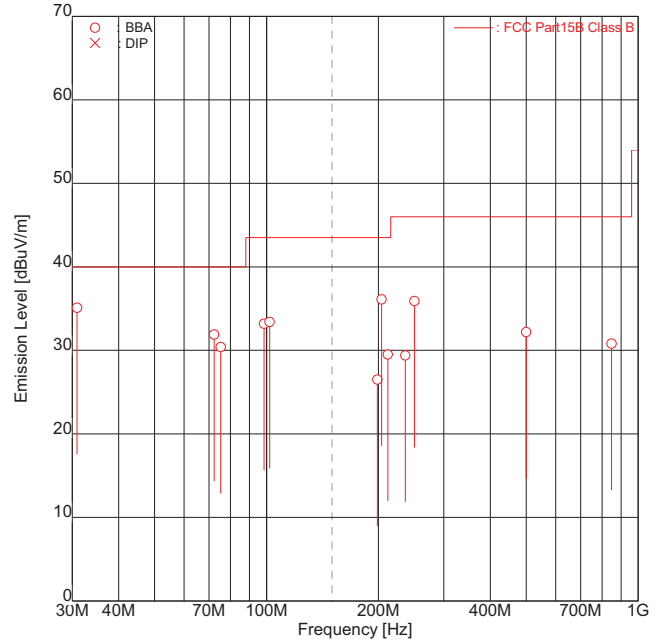

ENGINEER : Koichi Wagatsuma

FREQUENCY [No]	FREQ [MHz]	ANT.	MEMO	AZIMUTH [deg]		HEIGHT [cm]		EMISSION [dBuV/m]		LIMIT [dBuV/m]		MARGIN [dB]	
				Hori	Vert	Hori	Vert	Hori	Vert	Hori	Vert		
1	30.90	BBA		-	383	-	94	-	<u>35.1</u>	40.0	-	<u>4.9</u>	-
2	72.28	BBA		264	-	271	-	<u>31.9</u>	-	40.0	-	<u>8.1</u>	-
3	75.30	BBA		264	-	271	-	<u>30.4</u>	-	40.0	-	<u>9.6</u>	-
4	98.47	BBA		-	56	-	111	-	33.2	43.5	-	-	10.3
5	101.91	BBA		-	148	-	98	-	<u>33.4</u>	43.5	-	-	<u>10.1</u>
6	198.78	BBA		221	-	176	-	26.5	-	43.5	17.0	-	-
7	204.03	BBA		261	343	232	268	<u>36.1</u>	32.9	43.5	<u>7.4</u>	10.6	-
8	212.15	BBA		-	55	-	100	-	29.5	43.5	-	14.0	-
9	236.25	BBA		148	-	176	-	29.4	-	46.0	16.6	-	-
10	250.00	BBA		139	190	137	107	35.1	<u>35.9</u>	46.0	10.9	<u>10.1</u>	-
11	500.00	BBA		357	-	114	-	32.2	-	46.0	13.8	-	-
12	848.60	BBA		-	-	-	-	-	30.8	46.0	-	15.2	-

Higher six points are underlined.

Other frequencies : Below the FCC Part15B Class B limit

Emission Level = Read + Factor(Antenna,Antenna Pad,Cable,Preamp)

ANT. : Used antenna(BBA = Broadband antenna, DIP = Dipole antenna)

(Factor = Ant. Fact. + Cable Loss - Amp. Gain + Att. - Dist. Conversion Fact.)

emiT 3, 0, 0, 0

Copyright(c)2007 Intertek Japan K.K.

1000 – 25000 MHz

Intertek Japan K.K.

Tochigi No.1 Test Site

Radiated Electric Field

APPLICANT : JVCKENWOOD Corporation
 EUT NAME : 144/220/430MHz TRIBANDER
 MODEL NO. : TH-D74A
 SERIAL NO. : FES2 K-08
 TEST MODE : RX mode(155.00MHz: Band A)
 POWER SOURCE : DC 13.8V (AC120 V, 60 Hz)
 DATE TESTED : Jun 07 2016
 FILE NO. : -
 REGULATION : FCC Part15B Class B
 TEST METHOD : ANSI C63.4-2014
 DISTANCE : 3.73 [m]
 TEMPERATURE : 24.0 [degC]
 HUMIDITY : 50.0 [%]
 NOTE :

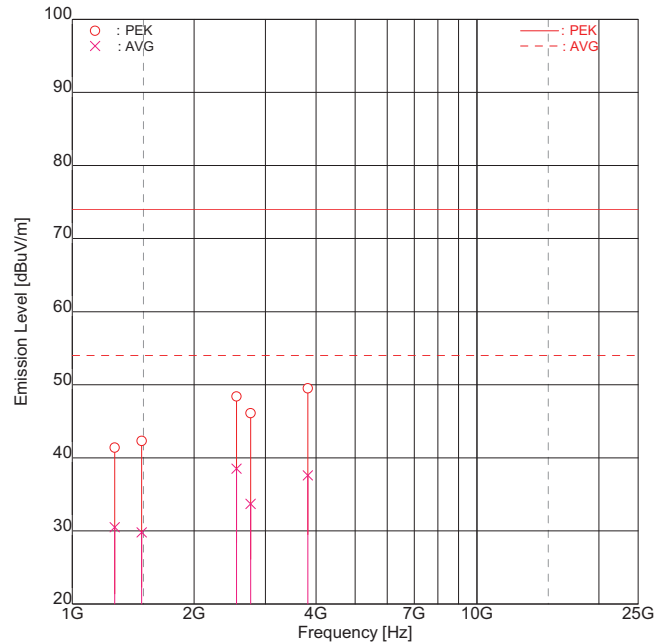

ENGINEER : Koichi Wagatuma

FREQUENCY [No]	MODE [MHz]		READING [dBuV]		FACTOR [dB]		EMISSION [dBuV/m]		LIMIT [dBuV/m]		MARGIN [dB]	
			Hori	Vert	Hori	Vert	Hori	Vert	Hori	Vert	Hori	Vert
1	1272.90	PEK	38.2	39.4	2.0	2.0	40.2	41.4	74.0	33.8	32.6	
2	1272.90	AVG	28.0	<u>28.5</u>	2.0	2.0	30.0	<u>30.5</u>	54.0	24.0	<u>23.5</u>	
3	1485.05	PEK	38.2	39.3	3.0	3.0	41.2	42.3	74.0	32.8	31.7	
4	1485.05	AVG	26.5	<u>26.8</u>	3.0	3.0	29.5	<u>29.8</u>	54.0	24.5	<u>24.2</u>	
5	2545.80	PEK	38.0	40.8	7.6	7.6	45.6	48.4	74.0	28.4	25.6	
6	2545.80	AVG	29.0	<u>30.9</u>	7.6	7.6	36.6	<u>38.5</u>	54.0	17.4	<u>15.5</u>	
7	2757.95	PEK	37.5	37.9	8.2	8.2	45.7	46.1	74.0	28.3	27.9	
8	2757.95	AVG	<u>25.5</u>	25.3	8.2	8.2	<u>33.7</u>	33.5	54.0	<u>20.3</u>	20.5	
9	3818.70	PEK	<u>38.0</u>	37.8	11.5	11.5	<u>49.5</u>	49.3	74.0	<u>24.5</u>	24.7	
10	3818.70	AVG	<u>26.1</u>	25.6	11.5	11.5	<u>37.6</u>	37.1	54.0	<u>16.4</u>	16.9	

Higher six points are underlined.

Emission Level = Read + Factor(Antenna, Antenna Pad, Cable, Preamp)

ANT. : Used antenna(BBA = Broadband antenna, DIP = Dipole antenna)

(Factor = Ant.Fact. + Cable Loss - Amp.Gain + Att. - Dist.Conversion Fact.)

**9.1.2.3 RX mode(173.995MHz : Band A)
 30 – 1000 MHz**

Intertek Japan K.K.

Tochigi No.3 Test Site

Radiated Electric Field

APPLICANT : JVCKENWOOD Corporation
 EUT NAME : 144/220/430MHz TRIBANDER
 MODEL NO. : TH-D74A
 SERIAL NO. : FES2 K-08
 TEST MODE : RX mode(173.995MHz;Band A)
 POWER SOURCE : DC13.8V(AC120 V, 60 Hz)
 DATE TESTED : May 31 2016
 FILE NO. : -
 REGULATION : FCC Part15B Class B
 TEST METHOD : ANSI C63.4-2014
 DISTANCE : 3.00 [m]
 TEMPERATURE : 25.7 [degC]
 HUMIDITY : 48.0 [%]
 NOTE :

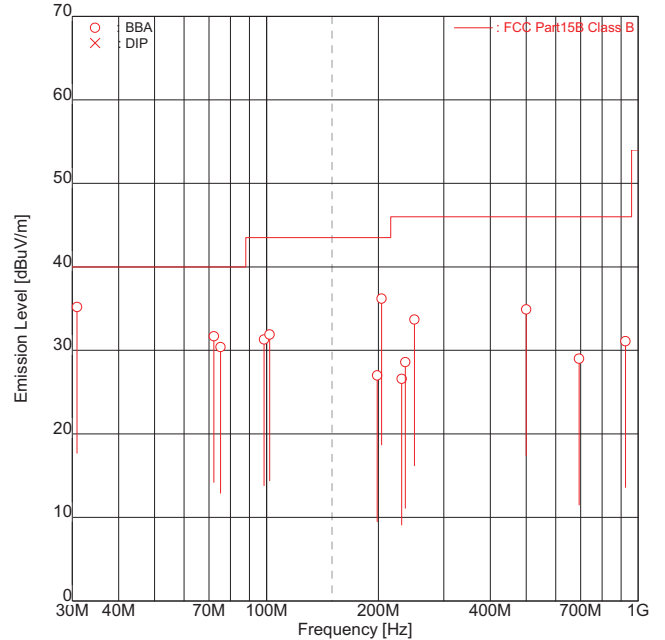

ENGINEER : Koichi Wagatsuma

FREQUENCY [No]	FREQ. [MHz]	ANT.	READING [dBuV]		FACTOR [dB/m]		EMISSION [dBuV/m]		LIMIT [dBuV/m]		MARGIN [dB]	
			Hori	Vert	Hori	Vert	Hori	Vert	Hori	Vert	Hori	Vert
1	30.90	BBA	-	<u>42.4</u>	-7.2	-7.2	-	<u>35.2</u>	40.0	-	-	<u>4.8</u>
2	72.22	BBA	<u>39.0</u>	-	-7.3	-7.3	<u>31.7</u>	-	40.0	-	-	<u>8.3</u>
3	75.23	BBA	<u>38.4</u>	-	-8.0	-8.0	<u>30.4</u>	-	40.0	-	-	<u>9.6</u>
4	98.47	BBA	-	40.8	-9.5	-9.5	-	31.3	43.5	-	-	12.2
5	101.91	BBA	-	<u>41.0</u>	-9.1	-9.1	-	<u>31.9</u>	43.5	-	-	<u>11.6</u>
6	198.60	BBA	34.0	-	-7.0	-7.0	27.0	-	43.5	16.5	-	-
7	204.03	BBA	<u>43.1</u>	37.0	-6.9	-6.9	<u>36.2</u>	30.1	43.5	<u>7.3</u>	13.4	-
8	231.15	BBA	32.2	30.0	-5.6	-5.6	26.6	24.4	46.0	19.4	21.6	-
9	236.25	BBA	34.0	-	-5.4	-5.4	28.6	-	46.0	17.4	-	-
10	250.00	BBA	38.6	31.5	-4.9	-4.9	33.7	26.6	46.0	12.3	19.4	-
11	500.00	BBA	<u>31.5</u>	-	3.4	3.4	<u>34.9</u>	-	46.0	<u>11.1</u>	-	-
12	693.43	BBA	-	21.1	7.9	7.9	-	29.0	46.0	-	17.0	-
13	924.58	BBA	19.2	19.1	11.9	11.9	31.1	31.0	46.0	14.9	15.0	-

Higher six points are underlined.
 Other frequencies : Below the FCC Part15B Class B limit
 Emission Level = Read + Factor(Antenna,Antenna Pad,Cable,Preamp)
 ANT. : Used antenna(BBA = Broadband antenna, DIP = Dipole antenna)
 (Factor = Ant. Fact. + Cable Loss - Amp. Gain + Att. - Dist. Conversion Fact.)

emiT 3, 0, 0, 0

Copyright(c)2007 Intertek Japan K.K.

1000 – 25000 MHz

Intertek Japan K.K.

Tochigi No.1 Test Site

Radiated Electric Field

APPLICANT : JVCKENWOOD Corporation
 EUT NAME : 144/220/430MHz TRIBANDER
 MODEL NO. : TH-D74A
 SERIAL NO. : FES2 K-08
 TEST MODE : RX mode(173.995MHz: Band A)
 POWER SOURCE : DC 13.8V (AC120 V, 60 Hz)
 DATE TESTED : Jun 07 2016
 FILE NO. : -
 REGULATION : FCC Part15B Class B
 TEST METHOD : ANSI C63.4-2014
 DISTANCE : 3.73 [m]
 TEMPERATURE : 21.6 [degC]
 HUMIDITY : 65.0 [%]
 NOTE :

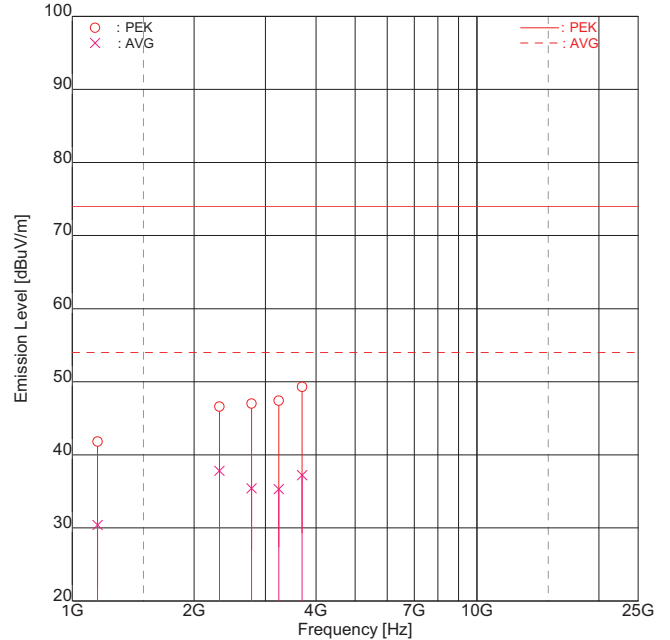

ENGINEER : Koichi Wagatuma

FREQUENCY [No]	MODE [MHz]		READING [dBuV]		FACTOR [dB]		EMISSION [dBuV/m]		LIMIT [dBuV/m]		MARGIN [dB]	
			Hori	Vert	Hori	Vert	Hori	Vert	Hori	Vert	Hori	Vert
1	1155.70	PEK	38.0	40.3	1.5	1.5	39.5	41.8	74.0	34.5	32.2	
2	1155.70	AVG	26.9	<u>28.9</u>	1.5	1.5	28.4	<u>30.4</u>	54.0	25.6	<u>23.6</u>	
3	2311.47	PEK	39.0	39.8	6.8	6.8	45.8	46.6	74.0	28.2	27.4	
4	2311.47	AVG	30.5	<u>31.0</u>	6.8	6.8	37.3	<u>37.8</u>	54.0	16.7	<u>16.2</u>	
5	2774.22	PEK	38.8	38.4	8.2	8.2	47.0	46.6	74.0	27.0	27.4	
6	2774.22	AVG	<u>27.2</u>	27.1	8.2	8.2	<u>35.4</u>	35.3	54.0	<u>18.6</u>	18.7	
7	3236.15	PEK	37.9	37.1	9.5	9.5	47.4	46.6	74.0	26.6	27.4	
8	3236.15	AVG	<u>25.8</u>	25.7	9.5	9.5	<u>35.3</u>	35.2	54.0	<u>18.7</u>	18.8	
9	3697.34	PEK	<u>38.2</u>	37.9	11.1	11.1	<u>49.3</u>	49.0	74.0	<u>24.7</u>	25.0	
10	3697.34	AVG	<u>26.1</u>	25.9	11.1	11.1	<u>37.2</u>	37.0	54.0	<u>16.8</u>	17.0	

Higher six points are underlined.
 Emission Level = Read + Factor(Antenna, Antenna Pad, Cable, Preamp)
 ANT. : Used antenna (BBA = Broadband antenna, DIP = Dipole antenna)
 (Factor = Ant. Fact. + Cable Loss - Amp. Gain + Att. - Dist. Conversion Fact.)

emiT 3, 0, 0, 0

Copyright(c)2007 Intertek Japan K.K.

**9.1.2.4 RX mode(216.00MHz : Band A)
 30 – 1000 MHz**

Intertek Japan K.K.

Tochigi No.3 Test Site

Radiated Electric Field

APPLICANT : JVCKENWOOD Corporation
 EUT NAME : 144/220/430MHz TRIBANDER
 MODEL NO. : TH-D74A
 SERIAL NO. : FES2 K-08
 TEST MODE : RX mode(216.00MHz;Band A)
 POWER SOURCE : DC13.8V(AC120 V, 60 Hz)
 DATE TESTED : May 31 2016
 FILE NO. : -
 REGULATION : FCC Part15B Class B
 TEST METHOD : ANSI C63.4-2014
 DISTANCE : 3.00 [m]
 TEMPERATURE : 25.7 [degC]
 HUMIDITY : 48.0 [%]
 NOTE :

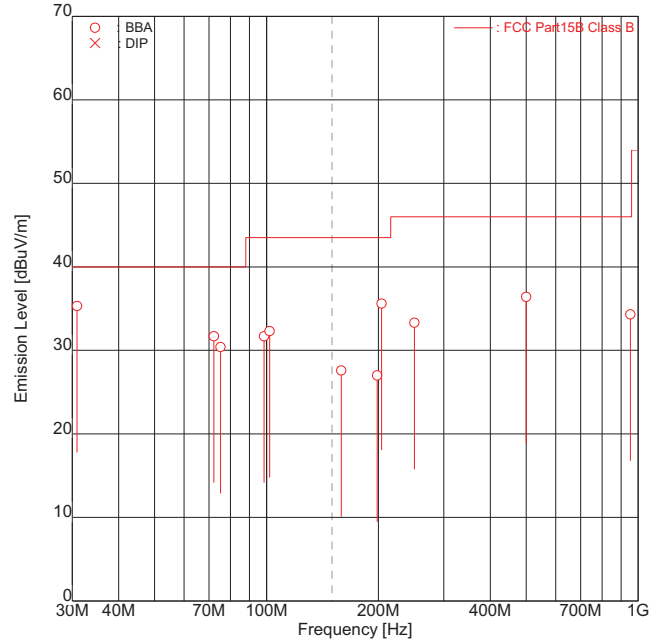

ENGINEER : Koichi Wagatsuma

FREQUENCY [No]	ANT. [MHz]	ANT.	READING [dBuV]		FACTOR [dB/m]		EMISSION [dBuV/m]		LIMIT [dBuV/m]		MARGIN [dB]	
			Hori	Vert	Hori	Vert	Hori	Vert	Hori	Vert		
1	30.90	BBA	-	<u>42.5</u>	-7.2	-7.2	-	<u>35.3</u>	40.0	-	-	<u>4.7</u>
2	72.22	BBA	<u>39.0</u>	-	-7.3	-7.3	<u>31.7</u>	-	40.0	-	-	<u>8.3</u>
3	75.23	BBA	<u>38.4</u>	-	-8.0	-8.0	<u>30.4</u>	-	40.0	-	-	<u>9.6</u>
4	98.47	BBA	-	41.2	-9.5	-9.5	-	31.7	43.5	-	-	11.8
5	101.91	BBA	-	<u>41.4</u>	-9.1	-9.1	-	<u>32.3</u>	43.5	-	-	<u>11.2</u>
6	158.85	BBA	30.5	<u>32.1</u>	-4.5	-4.5	26.0	<u>27.6</u>	43.5	17.5	-	<u>15.9</u>
7	198.60	BBA	34.0	-	-7.0	-7.0	27.0	-	43.5	16.5	-	-
8	204.03	BBA	<u>42.5</u>	37.0	-6.9	-6.9	<u>35.6</u>	30.1	43.5	<u>7.9</u>	-	13.4
9	250.00	BBA	38.2	32.2	-4.9	-4.9	33.3	27.3	46.0	12.7	-	18.7
10	500.00	BBA	<u>33.0</u>	-	3.4	3.4	<u>36.4</u>	-	46.0	<u>9.6</u>	-	-
11	953.10	BBA	-	22.0	12.3	12.3	-	34.3	46.0	-	-	11.7

Higher six points are underlined.
 Other frequencies : Below the FCC Part15B Class B limit
 Emission Level = Read + Factor(Antenna,Antenna Pad,Cable,Preamp)
 ANT. : Used antenna(BBA = Broadband antenna, DIP = Dipole antenna)
 (Factor = Ant. Fact. + Cable Loss - Amp. Gain + Att. - Dist. Conversion Fact.)

emiT 3, 0, 0, 0

Copyright(c)2007 Intertek Japan K.K.

1000 – 25000 MHz

Intertek Japan K.K.

Tochigi No.1 Test Site

Radiated Electric Field

APPLICANT : JVCKENWOOD Corporation
 EUT NAME : 144/220/430MHz TRIBANDER
 MODEL NO. : TH-D74A
 SERIAL NO. : FES2 K-08
 TEST MODE : RX mode(216.00MHz: Band A)
 POWER SOURCE : DC 13.8V (AC120 V, 60 Hz)
 DATE TESTED : Jun 07 2016
 FILE NO. : -
 REGULATION : FCC Part15B Class B
 TEST METHOD : ANSI C63.4-2014
 DISTANCE : 3.73 [m]
 TEMPERATURE : 21.6 [degC]
 HUMIDITY : 65.0 [%]
 NOTE :

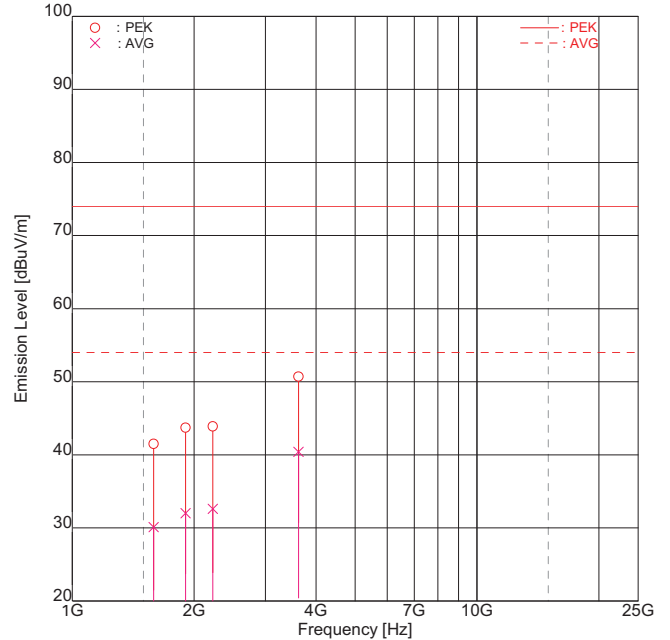

ENGINEER : Koichi Wagatuma

FREQUENCY [No]	MODE [MHz]		READING [dBuV]		FACTOR [dB]		EMISSION [dBuV/m]		LIMIT [dBuV/m]		MARGIN [dB]	
			Hori	Vert	Hori	Vert	Hori	Vert	Hori	Vert		
1	1588.50	PEK	37.6	38.0	3.5	3.5	41.1	41.5	74.0	32.9	32.5	
2	1588.50	AVG	<u>26.6</u>	26.5	3.5	3.5	<u>30.1</u>	30.0	54.0	<u>23.9</u>	24.0	
3	1906.20	PEK	37.5	38.3	5.4	5.4	42.9	43.7	74.0	31.1	30.3	
4	1906.20	AVG	<u>26.6</u>	26.3	5.4	5.4	<u>32.0</u>	31.7	54.0	<u>22.0</u>	22.3	
5	2223.90	PEK	36.9	<u>37.3</u>	6.6	6.6	43.5	<u>43.9</u>	74.0	30.5	<u>30.1</u>	
6	2223.90	AVG	<u>26.0</u>	26.0	6.6	6.6	<u>32.6</u>	32.6	54.0	<u>21.4</u>	21.4	
7	3623.79	PEK	38.8	<u>39.8</u>	10.9	10.9	49.7	<u>50.7</u>	74.0	24.3	<u>23.3</u>	
8	3623.79	AVG	26.7	<u>29.5</u>	10.9	10.9	37.6	<u>40.4</u>	54.0	16.4	<u>13.6</u>	

Higher six points are underlined.
 Emission Level = Read + Factor(Antenna, Antenna Pad, Cable, Preamp)
 ANT. : Used antenna(BBA = Broadband antenna, DIP = Dipole antenna)
 (Factor = Ant.Fact. + Cable Loss - Amp.Gain + Att. - Dist.Conversion Fact.)

emiT 3, 0, 0, 0

Copyright(c)2007 Intertek Japan K.K.

**9.1.2.5 RX mode(238.00MHz : Band A)
 30 – 1000 MHz**

Intertek Japan K.K.

Tochigi No.3 Test Site

Radiated Electric Field

APPLICANT : JVCKENWOOD Corporation
 EUT NAME : 144/220/430MHz TRIBANDER
 MODEL NO. : TH-D74A
 SERIAL NO. : FES2 K-08
 TEST MODE : RX mode(238.00MHz;Band A)
 POWER SOURCE : DC13.8V(AC120 V, 60 Hz)
 DATE TESTED : May 31 2016
 FILE NO. : -
 REGULATION : FCC Part15B Class B
 TEST METHOD : ANSI C63.4-2014
 DISTANCE : 3.00 [m]
 TEMPERATURE : 25.7 [degC]
 HUMIDITY : 48.0 [%]
 NOTE :

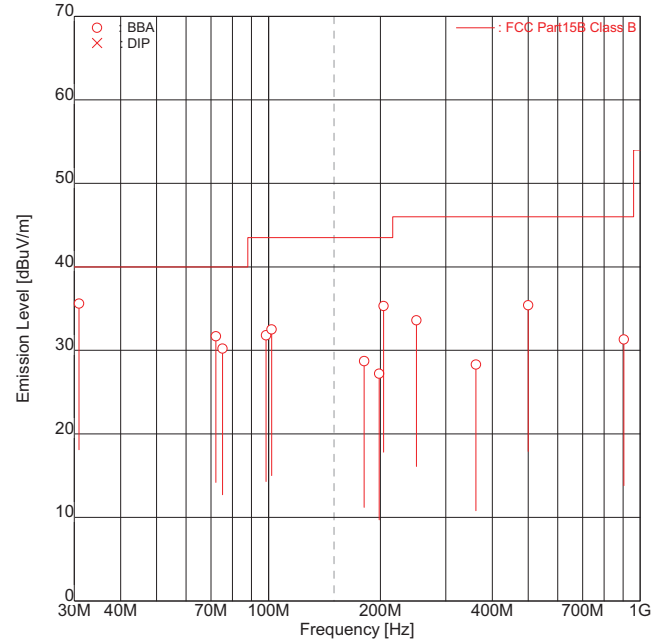

ENGINEER : Koichi Wagatsuma

FREQUENCY [No]	FREQ [MHz]	ANT.	READING [dBuV]		FACTOR [dB/m]		EMISSION [dBuV/m]		LIMIT [dBuV/m]	MARGIN [dB]	
			Hori	Vert	Hori	Vert	Hori	Vert		Hori	Vert
1	30.90	BBA	-	<u>42.8</u>	-7.2	-7.2	-	<u>35.6</u>	40.0	-	<u>4.4</u>
2	72.22	BBA	<u>39.0</u>	-	-7.3	-7.3	<u>31.7</u>	-	40.0	<u>8.3</u>	-
3	75.23	BBA	<u>38.2</u>	-	-8.0	-8.0	<u>30.2</u>	-	40.0	<u>9.8</u>	-
4	98.47	BBA	-	41.3	-9.5	-9.5	-	31.8	43.5	-	11.7
5	101.91	BBA	-	<u>41.6</u>	-9.1	-9.1	-	<u>32.5</u>	43.5	-	<u>11.0</u>
6	180.85	BBA	30.5	34.4	-5.7	-5.7	24.8	28.7	43.5	18.7	14.8
7	198.60	BBA	34.2	-	-7.0	-7.0	27.2	-	43.5	16.3	-
8	204.03	BBA	<u>42.2</u>	37.5	-6.9	-6.9	<u>35.3</u>	30.6	43.5	<u>8.2</u>	12.9
9	250.00	BBA	38.5	32.7	-4.9	-4.9	33.6	27.8	46.0	12.4	18.2
10	361.70	BBA	29.1	28.0	-0.8	-0.8	28.3	27.2	46.0	17.7	18.8
11	500.00	BBA	<u>32.0</u>	-	3.4	3.4	<u>35.4</u>	-	46.0	<u>10.6</u>	-
12	904.25	BBA	19.2	19.5	11.8	11.8	31.0	31.3	46.0	15.0	14.7

Higher six points are underlined.
 Other frequencies : Below the FCC Part15B Class B limit
 Emission Level = Read + Factor(Antenna,Antenna Pad,Cable,Preamp)
 ANT. : Used antenna(BBA = Broadband antenna, DIP = Dipole antenna)
 (Factor = Ant. Fact. + Cable Loss - Amp. Gain + Att. - Dist. Conversion Fact.)

emiT 3, 0, 0, 0

Copyright(c)2007 Intertek Japan K.K.

1000 – 25000 MHz

Intertek Japan K.K.

Tochigi No.1 Test Site

Radiated Electric Field

APPLICANT : JVCKENWOOD Corporation
 EUT NAME : 144/220/430MHz TRIBANDER
 MODEL NO. : TH-D74A
 SERIAL NO. : FES2 K-08
 TEST MODE : RX mode(238.00MHz: Band A)
 POWER SOURCE : DC 13.8V (AC120 V, 60 Hz)
 DATE TESTED : Jun 07 2016
 FILE NO. : -
 REGULATION : FCC Part15B Class B
 TEST METHOD : ANSI C63.4-2014
 DISTANCE : 3.73 [m]
 TEMPERATURE : 21.6 [degC]
 HUMIDITY : 65.0 [%]
 NOTE :

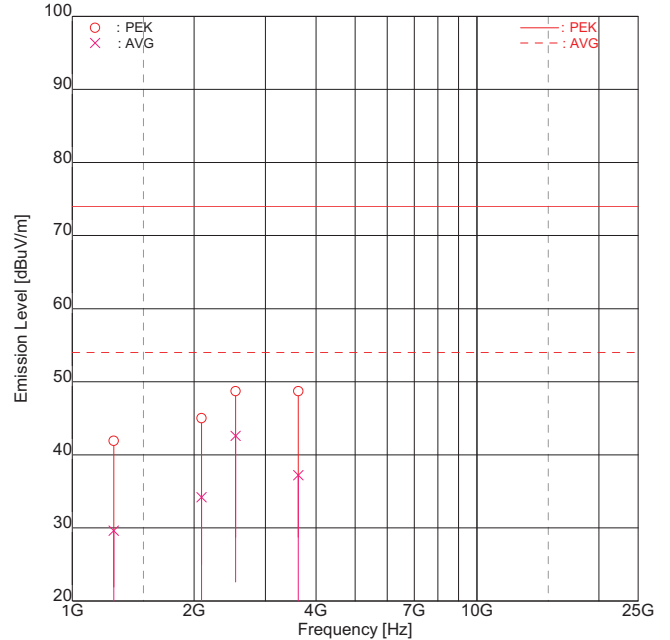

ENGINEER : Koichi Wagatuma

FREQUENCY [No]	MODE [MHz]		READING [dBuV]		FACTOR [dB]		EMISSION [dBuV/m]		LIMIT [dBuV/m]		MARGIN [dB]	
			Hori	Vert	Hori	Vert	Hori	Vert	Hori	Vert		
1	1265.95	PEK	39.1	39.9	2.0	2.0	41.1	41.9	74.0	32.9	32.1	
2	1265.95	AVG	27.1	<u>27.6</u>	2.0	2.0	29.1	<u>29.6</u>	54.0	24.9	<u>24.4</u>	
3	2531.90	PEK	40.6	<u>41.2</u>	7.5	7.5	48.1	<u>48.7</u>	74.0	25.9	<u>25.3</u>	
4	2531.90	AVG	31.7	<u>35.1</u>	7.5	7.5	39.2	<u>42.6</u>	54.0	14.8	<u>11.4</u>	
5	2086.60	PEK	38.8	38.6	6.2	6.2	45.0	44.8	74.0	29.0	29.2	
6	2086.60	AVG	27.8	<u>28.0</u>	6.2	6.2	34.0	<u>34.2</u>	54.0	20.0	<u>19.8</u>	
7	3617.00	PEK	<u>37.8</u>	37.5	10.9	10.9	<u>48.7</u>	48.4	74.0	<u>25.3</u>	25.6	
8	3617.00	AVG	<u>26.3</u>	25.9	10.9	10.9	<u>37.2</u>	36.8	54.0	<u>16.8</u>	17.2	

Higher six points are underlined.
 Emission Level = Read + Factor(Antenna, Antenna Pad, Cable, Preamp)
 ANT. : Used antenna(BBA = Broadband antenna, DIP = Dipole antenna)
 (Factor = Ant.Fact. + Cable Loss - Amp.Gain + Att. - Dist.Conversion Fact.)

emiT 3, 0, 0, 0

Copyright(c)2007 Intertek Japan K.K.

**9.1.2.6 RX mode(259.995MHz : Band A)
 30 – 1000 MHz**

Intertek Japan K.K.

Tochigi No.3 Test Site

Radiated Electric Field

APPLICANT : JVCKENWOOD Corporation
 EUT NAME : 144/220/430MHz TRIBANDER
 MODEL NO. : TH-D74A
 SERIAL NO. : FES2 K-08
 TEST MODE : RX mode(259.995MHz;Band A)
 POWER SOURCE : DC13.8V(AC120 V, 60 Hz)
 DATE TESTED : May 31 2016
 FILE NO. : -
 REGULATION : FCC Part15B Class B
 TEST METHOD : ANSI C63.4-2014
 DISTANCE : 3.00 [m]
 TEMPERATURE : 25.7 [degC]
 HUMIDITY : 48.0 [%]
 NOTE :

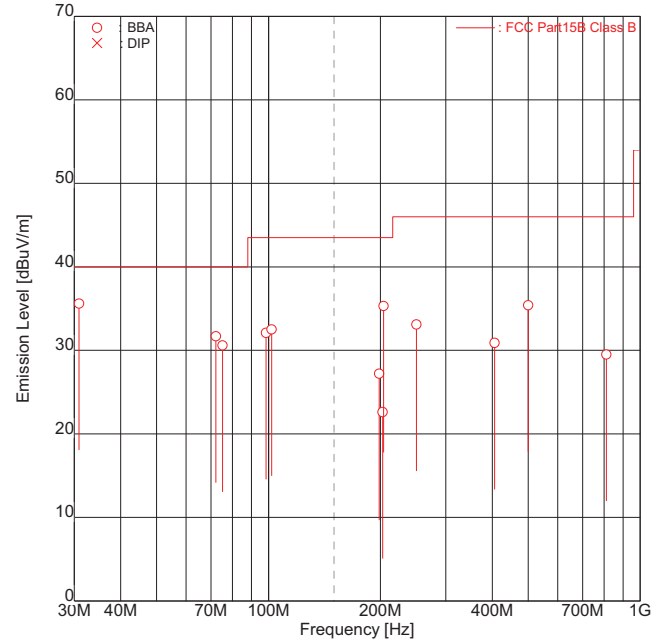

ENGINEER : Koichi Wagatsuma

FREQUENCY [No]	FREQ. [MHz]	ANT.	READING [dBuV]		FACTOR [dB/m]		EMISSION [dBuV/m]		LIMIT [dBuV/m]		MARGIN [dB]	
			Hori	Vert	Hori	Vert	Hori	Vert	Hori	Vert	Hori	Vert
1	30.90	BBA	-	<u>42.8</u>	-7.2	-7.2	-	<u>35.6</u>	40.0	-	<u>4.4</u>	-
2	72.22	BBA	<u>39.0</u>	-	-7.3	-7.3	<u>31.7</u>	-	40.0	-	<u>8.3</u>	-
3	75.23	BBA	<u>38.6</u>	-	-8.0	-8.0	<u>30.6</u>	-	40.0	-	<u>9.4</u>	-
4	98.47	BBA	-	41.6	-9.5	-9.5	-	32.1	43.5	-	-	11.4
5	101.91	BBA	-	<u>41.6</u>	-9.1	-9.1	-	<u>32.5</u>	43.5	-	-	<u>11.0</u>
6	198.60	BBA	34.2	-	-7.0	-7.0	27.2	-	43.5	16.3	-	-
7	202.85	BBA	-	29.6	-7.0	-7.0	-	22.6	43.5	-	-	20.9
8	204.03	BBA	<u>42.2</u>	38.0	-6.9	-6.9	<u>35.3</u>	31.1	43.5	<u>8.2</u>	12.4	-
9	250.00	BBA	38.0	32.3	-4.9	-4.9	33.1	27.4	46.0	12.9	18.6	-
10	405.69	BBA	30.3	26.9	0.6	0.6	30.9	27.5	46.0	15.1	18.5	-
11	500.00	BBA	<u>32.0</u>	-	3.4	3.4	<u>35.4</u>	-	46.0	<u>10.6</u>	-	-
12	811.38	BBA	19.2	19.3	10.2	10.2	29.4	29.5	46.0	16.6	16.5	-

Higher six points are underlined.
 Other frequencies : Below the FCC Part15B Class B limit
 Emission Level = Read + Factor(Antenna, Antenna Pad, Cable, Preamp)
 ANT. : Used antenna(BBA = Broadband antenna, DIP = Dipole antenna)
 (Factor = Ant. Fact. + Cable Loss - Amp. Gain + Att. - Dist. Conversion Fact.)

emiT 3, 0, 0, 0

Copyright(c)2007 Intertek Japan K.K.

1000 – 25000 MHz

Intertek Japan K.K.

Tochigi No.1 Test Site

Radiated Electric Field

APPLICANT : JVCKENWOOD Corporation
 EUT NAME : 144/220/430MHz TRIBANDER
 MODEL NO. : TH-D74A
 SERIAL NO. : FES2 K-08
 TEST MODE : RX mode(259.995MHz: Band A)
 POWER SOURCE : DC 13.8V (AC120 V, 60 Hz)
 DATE TESTED : Jun 07 2016
 FILE NO. : -
 REGULATION : FCC Part15B Class B
 TEST METHOD : ANSI C63.4-2014
 DISTANCE : 3.73 [m]
 TEMPERATURE : 21.6 [degC]
 HUMIDITY : 65.0 [%]
 NOTE :

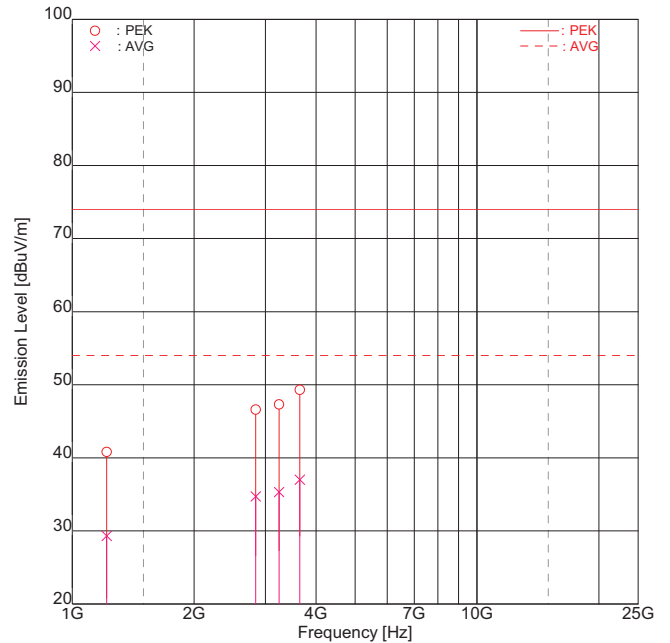

ENGINEER : Koichi Wagatuma

FREQUENCY [No]	MODE [MHz]		READING [dBuV]		FACTOR [dB]		EMISSION [dBuV/m]		LIMIT [dBuV/m]		MARGIN [dB]	
			Hori	Vert	Hori	Vert	Hori	Vert	Hori	Vert		
1	1217.07	PEK	38.2	39.0	1.8	1.8	40.0	40.8	74.0	34.0	33.2	
2	1217.07	AVG	26.7	<u>27.5</u>	1.8	1.8	28.5	<u>29.3</u>	54.0	25.5	<u>24.7</u>	
3	2839.83	PEK	38.0	<u>38.2</u>	8.4	8.4	46.4	46.6	74.0	27.6	<u>27.4</u>	
4	2839.83	AVG	<u>26.3</u>	26.1	8.4	8.4	<u>34.7</u>	34.5	54.0	<u>19.3</u>	19.5	
5	3245.52	PEK	<u>37.8</u>	37.4	9.5	9.5	<u>47.3</u>	46.9	74.0	<u>26.7</u>	27.1	
6	3245.52	AVG	25.7	<u>25.8</u>	9.5	9.5	35.2	<u>35.3</u>	54.0	18.8	<u>18.7</u>	
7	3651.21	PEK	37.9	<u>38.3</u>	11.0	11.0	48.9	<u>49.3</u>	74.0	25.1	<u>24.7</u>	
8	3651.21	AVG	<u>26.0</u>	25.9	11.0	11.0	<u>37.0</u>	36.9	54.0	<u>17.0</u>	17.1	

Higher six points are underlined.
 Emission Level = Read + Factor(Antenna, Antenna Pad, Cable, Preamp)
 ANT. : Used antenna(BBA = Broadband antenna, DIP = Dipole antenna)
 (Factor = Ant.Fact. + Cable Loss - Amp.Gain + Att. - Dist.Conversion Fact.)

emiT 3, 0, 0, 0

Copyright(c)2007 Intertek Japan K.K.

**9.1.2.7 RX mode(410.00MHz : Band A)
 30 – 1000 MHz**

Intertek Japan K.K.

Tochigi No.3 Test Site

Radiated Electric Field

APPLICANT : JVCKENWOOD Corporation
 EUT NAME : 144/220/430MHz TRIBANDER
 MODEL NO. : TH-D74A
 SERIAL NO. : FES2 K-08
 TEST MODE : RX mode(410.00MHz;Band A)
 POWER SOURCE : DC13.8V(AC120 V, 60 Hz)
 DATE TESTED : May 31 2016
 FILE NO. : -
 REGULATION : FCC Part15B Class B
 TEST METHOD : ANSI C63.4-2014
 DISTANCE : 3.00 [m]
 TEMPERATURE : 25.7 [degC]
 HUMIDITY : 48.0 [%]
 NOTE :

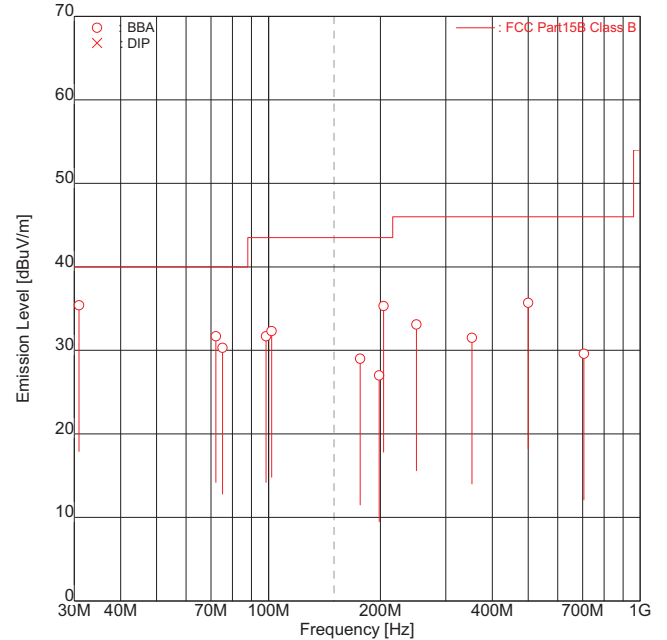

ENGINEER : Koichi Wagatsuma

FREQUENCY [No]	FREQ [MHz]	ANT.	READING [dBuV]		FACTOR [dB/m]		EMISSION [dBuV/m]		LIMIT [dBuV/m]		MARGIN [dB]	
			Hori	Vert	Hori	Vert	Hori	Vert	Hori	Vert		
1	30.90	BBA	-	<u>42.6</u>	-7.2	-7.2	-	<u>35.4</u>	40.0	-	<u>4.6</u>	-
2	72.22	BBA	<u>39.0</u>	-	-7.3	-7.3	<u>31.7</u>	-	40.0	-	<u>8.3</u>	-
3	75.23	BBA	<u>38.3</u>	-	-8.0	-8.0	<u>30.3</u>	-	40.0	-	<u>9.7</u>	-
4	98.47	BBA	-	41.2	-9.5	-9.5	-	31.7	43.5	-	-	11.8
5	101.91	BBA	-	<u>41.4</u>	-9.1	-9.1	-	<u>32.3</u>	43.5	-	-	<u>11.2</u>
6	176.43	BBA	30.3	<u>34.4</u>	-5.4	-5.4	24.9	29.0	43.5	18.6	14.5	-
7	198.60	BBA	34.0	-	-7.0	-7.0	27.0	-	43.5	16.5	-	-
8	204.03	BBA	<u>42.2</u>	37.7	-6.9	-6.9	<u>35.3</u>	30.8	43.5	<u>8.2</u>	12.7	-
9	250.00	BBA	38.0	32.5	-4.9	-4.9	33.1	27.6	46.0	12.9	18.4	-
10	352.85	BBA	32.3	32.6	-1.1	-1.1	31.2	31.5	46.0	14.8	14.5	-
11	500.00	BBA	<u>32.3</u>	-	3.4	3.4	<u>35.7</u>	-	46.0	<u>10.3</u>	-	-
12	705.70	BBA	20.2	21.5	8.1	8.1	28.3	29.6	46.0	17.7	16.4	-

Higher six points are underlined.
 Other frequencies : Below the FCC Part15B Class B limit
 Emission Level = Read + Factor(Antenna,Antenna Pad,Cable,Preamp)
 ANT. : Used antenna(BBA = Broadband antenna, DIP = Dipole antenna)
 (Factor = Ant. Fact. + Cable Loss - Amp. Gain + Att. - Dist. Conversion Fact.)

emiT 3, 0, 0, 0

Copyright(c)2007 Intertek Japan K.K.

1000 – 25000 MHz

Intertek Japan K.K.

Tochigi No.1 Test Site

Radiated Electric Field

APPLICANT : JVCKENWOOD Corporation
 EUT NAME : 144/220/430MHz TRIBANDER
 MODEL NO. : TH-D74A
 SERIAL NO. : FES2 K-08
 TEST MODE : RX mode(410.00MHz: Band A)
 POWER SOURCE : DC 13.8V (AC120 V, 60 Hz)
 DATE TESTED : Jun 07 2016
 FILE NO. : -
 REGULATION : FCC Part15B Class B
 TEST METHOD : ANSI C63.4-2014
 DISTANCE : 3.73 [m]
 TEMPERATURE : 21.6 [degC]
 HUMIDITY : 65.0 [%]
 NOTE :

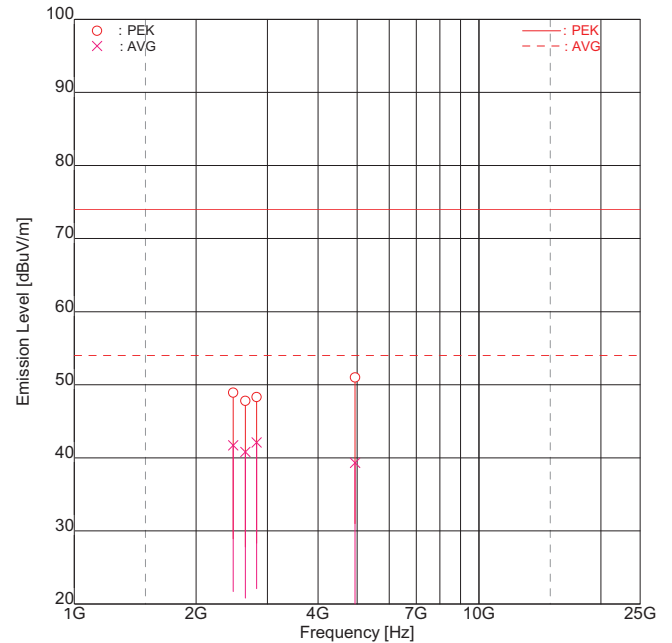

ENGINEER : Koichi Wagatuma

FREQUENCY [No]	MODE [MHz]		READING [dBuV]		FACTOR [dB]		EMISSION [dBuV/m]		LIMIT [dBuV/m]		MARGIN [dB]	
			Hori	Vert	Hori	Vert	Hori	Vert	Hori	Vert		
1	2469.95	PEK	40.0	<u>41.5</u>	7.4	7.4	47.4	<u>48.9</u>	74.0	26.6	<u>25.1</u>	
2	2469.95	AVG	33.3	<u>34.3</u>	7.4	7.4	40.7	<u>41.7</u>	54.0	13.3	<u>12.3</u>	
3	2646.38	PEK	40.0	39.5	7.8	7.8	47.8	47.3	74.0	26.2	26.7	
4	2646.38	AVG	<u>33.0</u>	31.0	7.8	7.8	<u>40.8</u>	38.8	54.0	<u>13.2</u>	15.2	
5	2822.80	PEK	40.0	40.0	8.3	8.3	48.3	48.3	74.0	25.7	25.7	
6	2822.80	AVG	<u>33.8</u>	31.0	8.3	8.3	<u>42.1</u>	39.3	54.0	<u>11.9</u>	14.7	
7	4939.90	PEK	<u>37.5</u>	37.3	13.5	13.5	<u>51.0</u>	50.8	74.0	<u>23.0</u>	23.2	
8	4939.90	AVG	<u>25.8</u>	25.5	13.5	13.5	<u>39.3</u>	39.0	54.0	<u>14.7</u>	15.0	

Higher six points are underlined.
 Emission Level = Read + Factor(Antenna, Antenna Pad, Cable, Preamp)
 ANT. : Used antenna(BBA = Broadband antenna, DIP = Dipole antenna)
 (Factor = Ant.Fact. + Cable Loss - Amp.Gain + Att. - Dist.Conversion Fact.)

emiT 3, 0, 0, 0

Copyright(c)2007 Intertek Japan K.K.

**9.1.2.8 RX mode(440.00MHz : Band A)
 30 – 1000 MHz**

Intertek Japan K.K.

Tochigi No.3 Test Site

Radiated Electric Field

APPLICANT : JVCKENWOOD Corporation
 EUT NAME : 144/220/430MHz TRIBANDER
 MODEL NO. : TH-D74A
 SERIAL NO. : FES2 K-08
 TEST MODE : RX mode(440.00MHz;Band A)
 POWER SOURCE : DC13.8V(AC120 V, 60 Hz)
 DATE TESTED : May 31 2016
 FILE NO. : -
 REGULATION : FCC Part15B Class B
 TEST METHOD : ANSI C63.4-2014
 DISTANCE : 3.00 [m]
 TEMPERATURE : 25.7 [degC]
 HUMIDITY : 48.0 [%]
 NOTE :

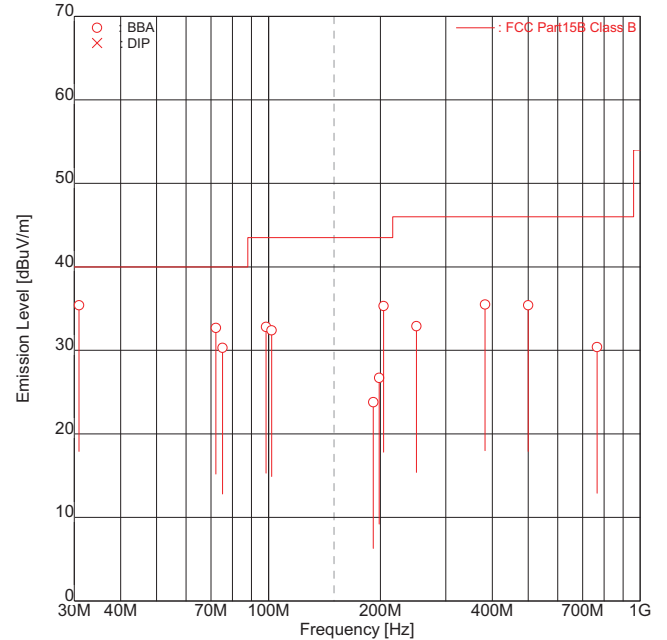

ENGINEER : Koichi Wagatsuma

FREQUENCY [No]	FREQ. [MHz]	ANT.	READING [dBuV]		FACTOR [dB/m]		EMISSION [dBuV/m]		LIMIT [dBuV/m]		MARGIN [dB]	
			Hori	Vert	Hori	Vert	Hori	Vert	Hori	Vert	Hori	Vert
1	30.90	BBA	-	<u>42.6</u>	-7.2	-7.2	-	<u>35.4</u>	40.0	-	<u>4.6</u>	-
2	72.22	BBA	<u>40.0</u>	-	-7.3	-7.3	<u>32.7</u>	-	40.0	-	<u>7.3</u>	-
3	75.23	BBA	<u>38.3</u>	-	-8.0	-8.0	<u>30.3</u>	-	40.0	-	<u>9.7</u>	-
4	98.47	BBA	-	42.3	-9.5	-9.5	-	32.8	43.5	-	-	10.7
5	101.91	BBA	-	41.5	-9.1	-9.1	-	32.4	43.5	-	-	11.1
6	191.43	BBA	26.6	30.2	-6.4	-6.4	20.2	23.8	43.5	23.3	19.7	19.7
7	198.64	BBA	33.7	-	-7.0	-7.0	26.7	-	43.5	16.8	-	-
8	204.03	BBA	<u>42.2</u>	37.7	-6.9	-6.9	<u>35.3</u>	30.8	43.5	<u>8.2</u>	12.7	12.7
9	250.00	BBA	37.8	-	-4.9	-4.9	32.9	-	46.0	13.1	-	-
10	382.86	BBA	<u>35.6</u>	33.1	-0.1	-0.1	<u>35.5</u>	33.0	46.0	<u>10.5</u>	13.0	13.0
11	500.00	BBA	<u>32.0</u>	-	3.4	3.4	<u>35.4</u>	-	46.0	<u>10.6</u>	-	-
12	765.70	BBA	21.0	20.7	9.4	9.4	30.4	30.1	46.0	15.6	15.9	15.9

Higher six points are underlined.
 Other frequencies : Below the FCC Part15B Class B limit
 Emission Level = Read + Factor(Antenna,Antenna Pad,Cable,Preamp)
 ANT. : Used antenna(BBA = Broadband antenna, DIP = Dipole antenna)
 (Factor = Ant. Fact. + Cable Loss - Amp. Gain + Att. - Dist. Conversion Fact.)

emiT 3, 0, 0, 0

Copyright(c)2007 Intertek Japan K.K.

1000 – 25000 MHz

Intertek Japan K.K.

Tochigi No.1 Test Site

Radiated Electric Field

APPLICANT : JVCKENWOOD Corporation
 EUT NAME : 144/220/430MHz TRIBANDER
 MODEL NO. : TH-D74A
 SERIAL NO. : FES2 K-08
 TEST MODE : RX mode(440.00MHz: Band A)
 POWER SOURCE : DC 13.8V (AC120 V, 60 Hz)
 DATE TESTED : Jun 07 2016
 FILE NO. : -
 REGULATION : FCC Part15B Class B
 TEST METHOD : ANSI C63.4-2014
 DISTANCE : 3.73 [m]
 TEMPERATURE : 21.6 [degC]
 HUMIDITY : 65.0 [%]
 NOTE :

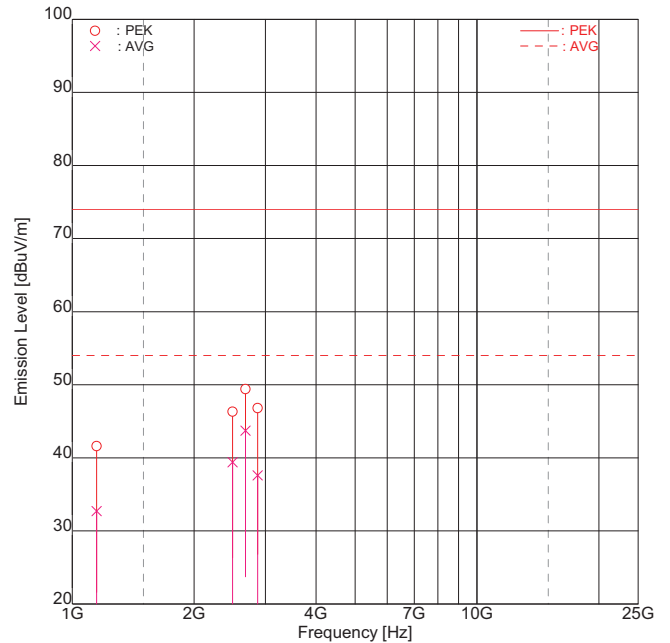

ENGINEER : Koichi Wagatuma

FREQUENCY [No]	MODE [MHz]		READING [dBuV]		FACTOR [dB]		EMISSION [dBuV/m]		LIMIT [dBuV/m]		MARGIN [dB]	
			Hori	Vert	Hori	Vert	Hori	Vert	Hori	Vert		
1	1148.55	PEK	38.0	40.2	1.4	1.4	39.4	41.6	74.0	34.6	32.4	
2	1148.55	AVG	28.7	<u>31.3</u>	1.4	1.4	30.1	<u>32.7</u>	54.0	23.9	<u>21.3</u>	
3	2488.53	PEK	38.9	<u>37.8</u>	7.4	7.4	46.3	<u>45.2</u>	74.0	27.7	<u>28.8</u>	
4	2488.53	AVG	31.6	<u>32.0</u>	7.4	7.4	39.0	<u>39.4</u>	54.0	15.0	<u>14.6</u>	
5	2679.95	PEK	41.3	<u>41.5</u>	7.9	7.9	49.2	<u>49.4</u>	74.0	24.8	<u>24.6</u>	
6	2679.95	AVG	34.1	<u>35.8</u>	7.9	7.9	42.0	<u>43.7</u>	54.0	12.0	<u>10.3</u>	
7	2871.38	PEK	37.9	<u>38.3</u>	8.5	8.5	46.4	<u>46.8</u>	74.0	27.6	<u>27.2</u>	
8	2871.38	AVG	<u>29.1</u>	27.5	8.5	8.5	<u>37.6</u>	36.0	54.0	<u>16.4</u>	18.0	

Higher six points are underlined.
 Emission Level = Read + Factor(Antenna, Antenna Pad, Cable, Preamp)
 ANT. : Used antenna(BBA = Broadband antenna, DIP = Dipole antenna)
 (Factor = Ant.Fact. + Cable Loss - Amp.Gain + Att. - Dist.Conversion Fact.)

emiT 3, 0, 0, 0

Copyright(c)2007 Intertek Japan K.K.

**9.1.2.9 RX mode(469.995MHz : Band A)
 30 – 1000 MHz**

Intertek Japan K.K.

Tochigi No.3 Test Site

Radiated Electric Field

APPLICANT : JVCKENWOOD Corporation
 EUT NAME : 144/220/430MHz TRIBANDER
 MODEL NO. : TH-D74A
 SERIAL NO. : FES2 K-08
 TEST MODE : RX mode(469.995MHz;Band A)
 POWER SOURCE : DC13.8V(AC120 V, 60 Hz)
 DATE TESTED : May 31 2016
 FILE NO. : -
 REGULATION : FCC Part15B Class B
 TEST METHOD : ANSI C63.4-2014
 DISTANCE : 3.00 [m]
 TEMPERATURE : 25.7 [degC]
 HUMIDITY : 48.0 [%]
 NOTE :

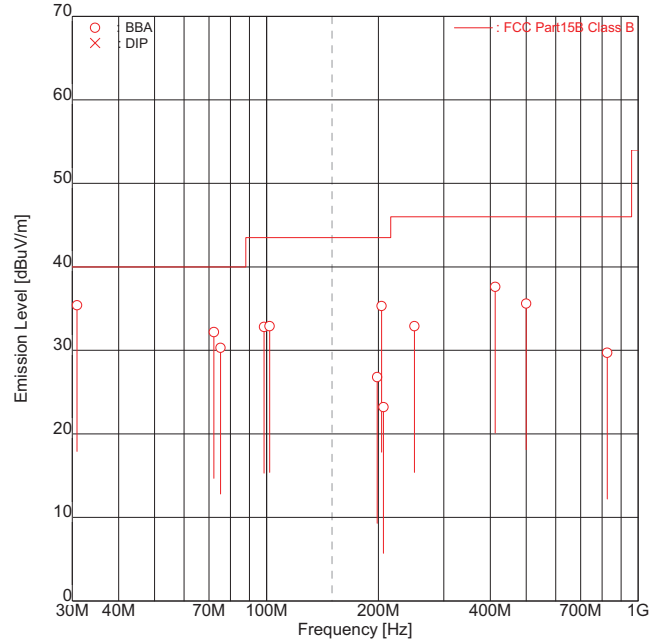

ENGINEER : Koichi Wagatsuma

FREQUENCY [No]	FREQ [MHz]	ANT.	READING [dBuV]		FACTOR [dB/m]		EMISSION [dBuV/m]		LIMIT [dBuV/m]		MARGIN [dB]	
			Hori	Vert	Hori	Vert	Hori	Vert	Hori	Vert		
1	30.90	BBA	-	<u>42.6</u>	-7.2	-7.2	-	<u>35.4</u>	40.0	-	-	<u>4.6</u>
2	72.22	BBA	<u>39.5</u>	-	-7.3	-7.3	<u>32.2</u>	-	40.0	-	-	<u>7.8</u>
3	75.23	BBA	<u>38.3</u>	-	-8.0	-8.0	<u>30.3</u>	-	40.0	-	-	<u>9.7</u>
4	98.47	BBA	-	42.3	-9.5	-9.5	-	32.8	43.5	-	-	10.7
5	101.91	BBA	-	42.0	-9.1	-9.1	-	32.9	43.5	-	-	10.6
6	198.64	BBA	33.8	-	-7.0	-7.0	26.8	-	43.5	-	16.7	-
7	204.03	BBA	<u>42.2</u>	37.7	-6.9	-6.9	<u>35.3</u>	30.8	43.5	-	-	<u>8.2</u>
8	206.42	BBA	28.0	30.0	-6.8	-6.8	21.2	23.2	43.5	22.3	20.3	-
9	250.00	BBA	37.8	-	-4.9	-4.9	32.9	-	46.0	-	-	13.1
10	412.85	BBA	<u>36.8</u>	36.6	0.8	0.8	<u>37.6</u>	37.4	46.0	-	-	<u>8.4</u>
11	500.00	BBA	<u>32.2</u>	-	3.4	3.4	<u>35.6</u>	-	46.0	-	-	<u>10.4</u>
12	825.69	BBA	19.3	19.3	10.4	10.4	29.7	29.7	46.0	16.3	16.3	-

Higher six points are underlined.
 Other frequencies : Below the FCC Part15B Class B limit
 Emission Level = Read + Factor(Antenna,Antenna Pad,Cable,Preamp)
 ANT. : Used antenna(BBA = Broadband antenna, DIP = Dipole antenna)
 (Factor = Ant. Fact. + Cable Loss - Amp. Gain + Att. - Dist. Conversion Fact.)

emiT 3, 0, 0, 0

Copyright(c)2007 Intertek Japan K.K.

1000 – 25000 MHz

Intertek Japan K.K.

Tochigi No.1 Test Site

Radiated Electric Field

APPLICANT : JVCKENWOOD Corporation
 EUT NAME : 144/220/430MHz TRIBANDER
 MODEL NO. : TH-D74A
 SERIAL NO. : FES2 K-08
 TEST MODE : RX mode(469.995MHz: Band A)
 POWER SOURCE : DC 13.8V (AC120 V, 60 Hz)
 DATE TESTED : Jun 07 2016
 FILE NO. : -
 REGULATION : FCC Part15B Class B
 TEST METHOD : ANSI C63.4-2014
 DISTANCE : 3.73 [m]
 TEMPERATURE : 21.6 [degC]
 HUMIDITY : 65.0 [%]
 NOTE :

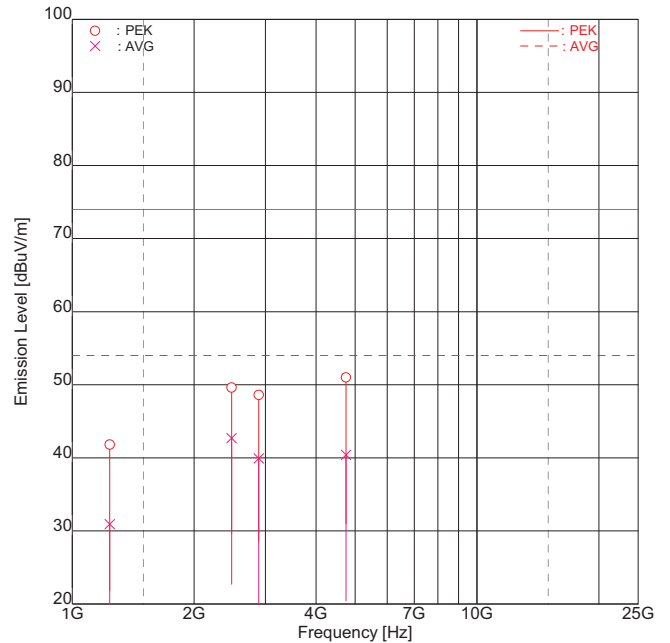

ENGINEER : Koichi Wagatuma

FREQUENCY [No]	MODE [MHz]		READING [dBuV]		FACTOR [dB]		EMISSION [dBuV/m]		LIMIT [dBuV/m]		MARGIN [dB]	
			Hori	Vert	Hori	Vert	Hori	Vert	Hori	Vert		
1	1238.54	PEK	39.9	39.4	1.9	1.9	41.8	41.3	74.0	32.2	32.7	
2	1238.54	AVG	28.0	<u>29.0</u>	1.9	1.9	29.9	<u>30.9</u>	54.0	24.1	<u>23.1</u>	
3	2477.07	PEK	39.8	<u>42.2</u>	7.4	7.4	47.2	<u>49.6</u>	74.0	26.8	<u>24.4</u>	
4	2477.07	AVG	30.6	<u>35.3</u>	7.4	7.4	38.0	<u>42.7</u>	54.0	16.0	<u>11.3</u>	
5	2889.92	PEK	39.7	40.1	8.5	8.5	48.2	48.6	74.0	25.8	25.4	
6	2889.92	AVG	30.4	<u>31.4</u>	8.5	8.5	38.9	<u>39.9</u>	54.0	15.1	<u>14.1</u>	
7	4747.72	PEK	<u>38.1</u>	37.1	12.9	12.9	<u>51.0</u>	50.0	74.0	<u>23.0</u>	24.0	
8	4747.72	AVG	<u>27.5</u>	26.0	12.9	12.9	<u>40.4</u>	38.9	54.0	<u>13.6</u>	15.1	

Higher six points are underlined.
 Emission Level = Read + Factor(Antenna, Antenna Pad, Cable, Preamp)
 ANT. : Used antenna(BBA = Broadband antenna, DIP = Dipole antenna)
 (Factor = Ant.Fact. + Cable Loss - Amp.Gain + Att. - Dist.Conversion Fact.)

emiT 3, 0, 0, 0

Copyright(c)2007 Intertek Japan K.K.

**9.1.2.10 RX mode(0.10MHz : Band B)
 30 – 1000 MHz**

Intertek Japan K.K.

Tochigi No.3 Test Site

Radiated Electric Field

APPLICANT : JVCKENWOOD Corporation
 EUT NAME : 144/220/430MHz TRIBANDER
 MODEL NO. : TH-D74A
 SERIAL NO. : FES2 K-08
 TEST MODE : RX mode(0.100MHz;Band B)
 POWER SOURCE : DC13.8V(AC120 V, 60 Hz)
 DATE TESTED : May 31 2016
 FILE NO. : -
 REGULATION : FCC Part15B Class B
 TEST METHOD : ANSI C63.4-2014
 DISTANCE : 3.00 [m]
 TEMPERATURE : 25.7 [degC]
 HUMIDITY : 48.0 [%]
 NOTE :

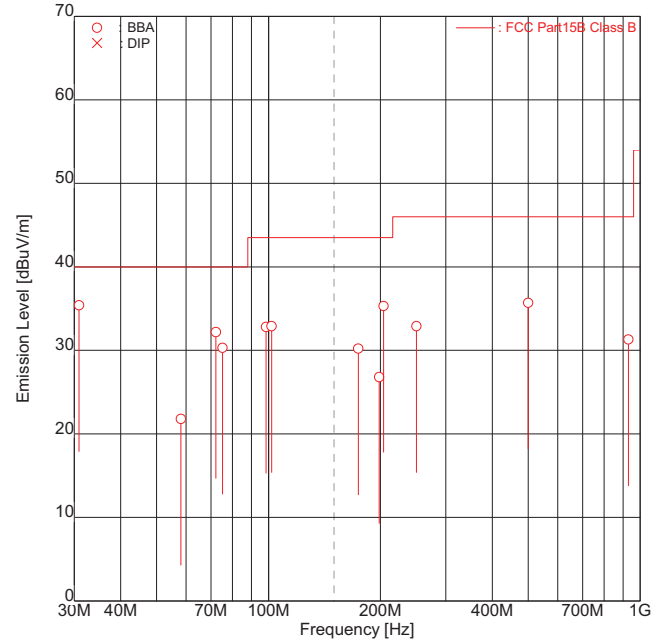

ENGINEER : Koichi Wagatsuma

FREQUENCY [No]	ANT. [MHz]	ANT.	READING [dBuV]		FACTOR [dB/m]		EMISSION [dBuV/m]		LIMIT [dBuV/m]	MARGIN [dB]	
			Hori	Vert	Hori	Vert	Hori	Vert		Hori	Vert
1	30.90	BBA	-	<u>42.6</u>	-7.2	-7.2	-	<u>35.4</u>	40.0	-	<u>4.6</u>
2	58.15	BBA	-	27.2	-5.4	-5.4	-	21.8	40.0	-	18.2
3	72.22	BBA	<u>39.5</u>	-	-7.3	-7.3	<u>32.2</u>	-	40.0	<u>7.8</u>	-
4	75.23	BBA	<u>38.3</u>	-	-8.0	-8.0	<u>30.3</u>	-	40.0	<u>9.7</u>	-
5	98.47	BBA	-	42.3	-9.5	-9.5	-	32.8	43.5	-	10.7
6	101.91	BBA	-	<u>42.0</u>	-9.1	-9.1	-	<u>32.9</u>	43.5	-	<u>10.6</u>
7	174.45	BBA	31.1	<u>35.5</u>	-5.3	-5.3	25.8	<u>30.2</u>	43.5	17.7	<u>13.3</u>
8	198.64	BBA	33.8	-	-7.0	-7.0	26.8	-	43.5	16.7	-
9	204.03	BBA	<u>42.2</u>	37.7	-6.9	-6.9	<u>35.3</u>	30.8	43.5	<u>8.2</u>	12.7
10	250.00	BBA	37.8	-	-4.9	-4.9	32.9	-	46.0	13.1	-
11	500.00	BBA	<u>32.3</u>	-	3.4	3.4	<u>35.7</u>	-	46.0	<u>10.3</u>	-
12	930.40	BBA	-	19.3	12.0	12.0	-	31.3	46.0	-	14.7

Higher six points are underlined.
 Other frequencies : Below the FCC Part15B Class B limit
 Emission Level = Read + Factor(Antenna,Antenna Pad,Cable,Preamp)
 ANT. : Used antenna(BBA = Broadband antenna, DIP = Dipole antenna)
 (Factor = Ant. Fact. + Cable Loss - Amp. Gain + Att. - Dist. Conversion Fact.)

emiT 3, 0, 0, 0

Copyright(c)2007 Intertek Japan K.K.

1000 – 25000 MHz

Intertek Japan K.K.

Tochigi No.1 Test Site

Radiated Electric Field

APPLICANT : JVCKENWOOD Corporation
 EUT NAME : 144/220/430MHz TRIBANDER
 MODEL NO. : TH-D74A
 SERIAL NO. : FES2 K-08
 TEST MODE : RX mode(0.10MHz: Band B)
 POWER SOURCE : DC 13.8V (AC120 V, 60 Hz)
 DATE TESTED : Jun 07 2016
 FILE NO. : -
 REGULATION : FCC Part15B Class B
 TEST METHOD : ANSI C63.4-2014
 DISTANCE : 3.73 [m]
 TEMPERATURE : 21.6 [degC]
 HUMIDITY : 65.0 [%]
 NOTE :

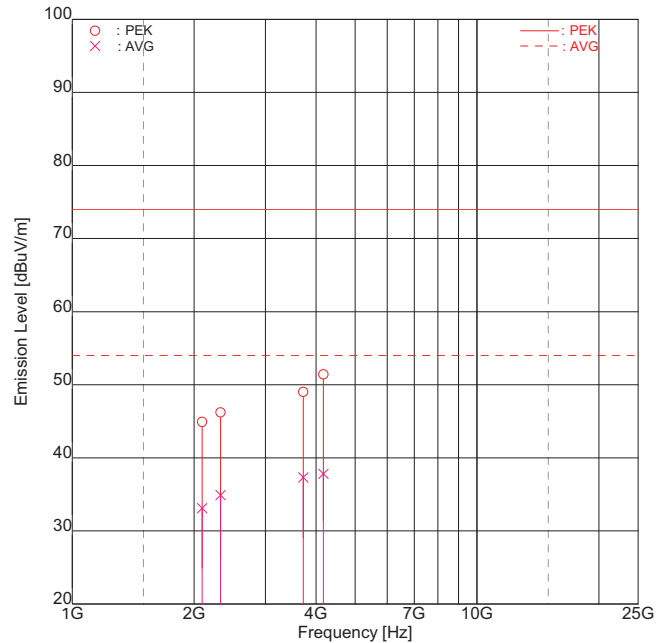

ENGINEER : Koichi Wagatuma

FREQUENCY [No]	MODE [MHz]		READING [dBuV]		FACTOR [dB]		EMISSION [dBuV/m]		LIMIT [dBuV/m]	MARGIN [dB]	
			Hori	Vert	Hori	Vert	Hori	Vert		Hori	Vert
1	2093.40	PEK	38.7	38.4	6.2	6.2	44.9	44.6	74.0	29.1	29.4
2	2093.40	AVG	<u>26.9</u>	26.3	6.2	6.2	<u>33.1</u>	32.5	54.0	<u>20.9</u>	21.5
3	2326.00	PEK	39.0	39.4	6.8	6.8	45.8	46.2	74.0	28.2	27.8
4	2326.00	AVG	<u>28.1</u>	27.7	6.8	6.8	<u>34.9</u>	34.5	54.0	<u>19.1</u>	19.5
5	3721.60	PEK	<u>37.8</u>	36.8	11.2	11.2	<u>49.0</u>	48.0	74.0	<u>25.0</u>	26.0
6	3721.60	AVG	<u>26.1</u>	26.0	11.2	11.2	<u>37.3</u>	37.2	54.0	<u>16.7</u>	16.8
7	4172.97	PEK	39.0	<u>39.4</u>	12.0	12.0	51.0	<u>51.4</u>	74.0	23.0	<u>22.6</u>
8	4172.97	AVG	25.7	<u>25.8</u>	12.0	12.0	37.7	<u>37.8</u>	54.0	16.3	<u>16.2</u>

Higher six points are underlined.
 Emission Level = Read + Factor(Antenna, Antenna Pad, Cable, Preamp)
 ANT. : Used antenna(BBA = Broadband antenna, DIP = Dipole antenna)
 (Factor = Ant.Fact. + Cable Loss - Amp.Gain + Att. - Dist.Conversion Fact.)

emiT 3, 0, 0, 0

Copyright(c)2007 Intertek Japan K.K.

**9.1.2.11 RX mode(262.00MHz : Band B)
 30 – 1000 MHz**

Intertek Japan K.K.

Tochigi No.3 Test Site

Radiated Electric Field

APPLICANT : JVCKENWOOD Corporation
 EUT NAME : 144/220/430MHz TRIBANDER
 MODEL NO. : TH-D74A
 SERIAL NO. : FES2 K-08
 TEST MODE : RX mode(262.00MHz;Band B)
 POWER SOURCE : DC13.8V(AC120 V, 60 Hz)
 DATE TESTED : May 31 2016
 FILE NO. : -
 REGULATION : FCC Part15B Class B
 TEST METHOD : ANSI C63.4-2014
 DISTANCE : 3.00 [m]
 TEMPERATURE : 25.7 [degC]
 HUMIDITY : 48.0 [%]
 NOTE :

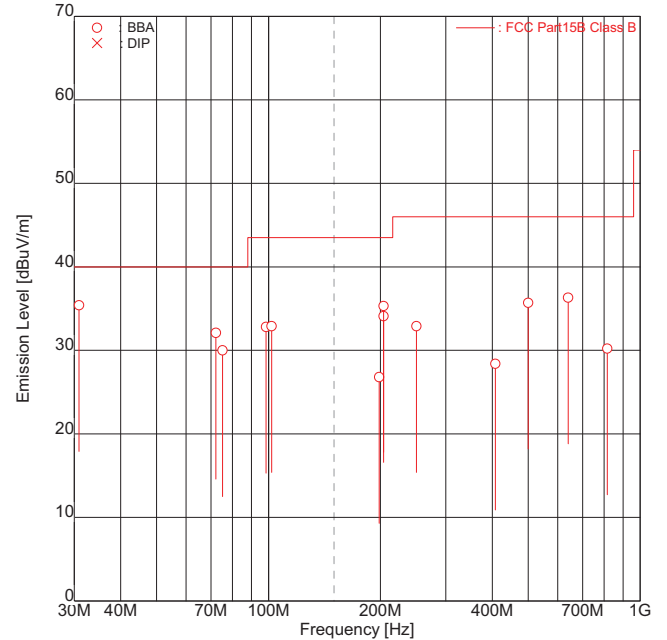

ENGINEER : Koichi Wagatsuma

FREQUENCY [No]	FREQ. [MHz]	ANT.	READING [dBuV]		FACTOR [dB/m]		EMISSION [dBuV/m]		LIMIT [dBuV/m]		MARGIN [dB]	
			Hori	Vert	Hori	Vert	Hori	Vert	Hori	Vert		
1	30.90	BBA	-	<u>42.6</u>	-7.2	-7.2	-	<u>35.4</u>	40.0	-	-	<u>4.6</u>
2	72.22	BBA	<u>39.4</u>	-	-7.3	-7.3	<u>32.1</u>	-	40.0	-	<u>7.9</u>	-
3	75.23	BBA	<u>38.0</u>	-	-8.0	-8.0	<u>30.0</u>	-	40.0	-	<u>10.0</u>	-
4	98.47	BBA	-	42.3	-9.5	-9.5	-	32.8	43.5	-	-	10.7
5	101.91	BBA	-	42.0	-9.1	-9.1	-	32.9	43.5	-	-	10.6
6	198.64	BBA	33.8	-	-7.0	-7.0	26.8	-	43.5	-	16.7	-
7	203.95	BBA	<u>41.0</u>	36.5	-6.9	-6.9	<u>34.1</u>	29.6	43.5	-	<u>9.4</u>	13.9
8	204.03	BBA	<u>42.2</u>	37.7	-6.9	-6.9	<u>35.3</u>	30.8	43.5	-	<u>8.2</u>	12.7
9	250.00	BBA	37.8	-	-4.9	-4.9	32.9	-	46.0	-	13.1	-
10	407.90	BBA	27.8	25.7	0.6	0.6	28.4	26.3	46.0	-	17.6	19.7
11	500.00	BBA	32.3	-	3.4	3.4	35.7	-	46.0	-	10.3	-
12	640.10	BBA	<u>29.5</u>	29.2	6.8	6.8	<u>36.3</u>	36.0	46.0	-	<u>9.7</u>	10.0
13	815.80	BBA	20.0	19.3	10.2	10.2	30.2	29.5	46.0	-	15.8	16.5

Higher six points are underlined.
 Other frequencies : Below the FCC Part15B Class B limit
 Emission Level = Read + Factor(Antenna,Antenna Pad,Cable,Preamp)
 ANT. : Used antenna(BBA = Broadband antenna, DIP = Dipole antenna)
 (Factor = Ant. Fact. + Cable Loss - Amp. Gain + Att. - Dist. Conversion Fact.)

emiT 3, 0, 0, 0

Copyright(c)2007 Intertek Japan K.K.

1000 – 25000 MHz

Intertek Japan K.K.

Tochigi No.1 Test Site

Radiated Electric Field

APPLICANT : JVCKENWOOD Corporation
 EUT NAME : 144/220/430MHz TRIBANDER
 MODEL NO. : TH-D74A
 SERIAL NO. : FES2 K-08
 TEST MODE : RX mode(262.00MHz: Band B)
 POWER SOURCE : DC 13.8V (AC120 V, 60 Hz)
 DATE TESTED : Jun 07 2016
 FILE NO. : -
 REGULATION : FCC Part15B Class B
 TEST METHOD : ANSI C63.4-2014
 DISTANCE : 3.73 [m]
 TEMPERATURE : 21.6 [degC]
 HUMIDITY : 65.0 [%]
 NOTE :

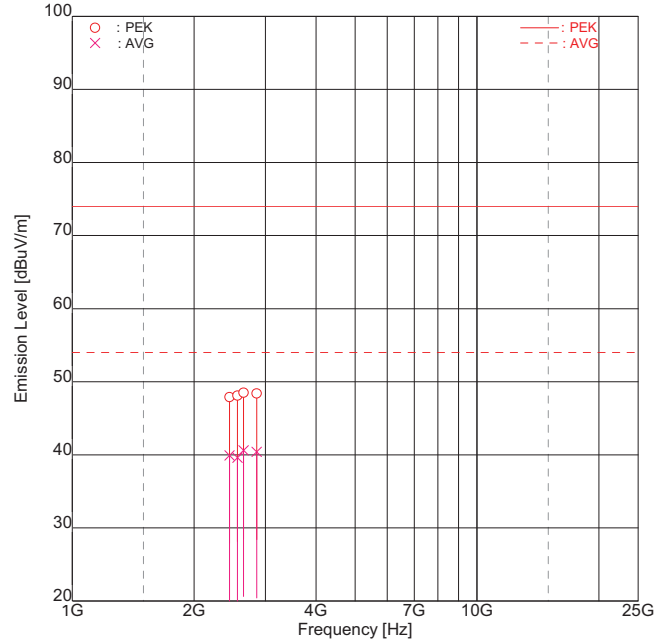

ENGINEER : Koichi Wagatuma

FREQUENCY [No]	MODE [MHz]		READING [dBuV]		FACTOR [dB]		EMISSION [dBuV/m]		LIMIT [dBuV/m]		MARGIN [dB]	
			Hori	Vert	Hori	Vert	Hori	Vert	Hori	Vert	Hori	Vert
1	2447.40	PEK	40.3	40.6	7.3	7.3	47.6	47.9	74.0	26.4	26.1	
2	2447.40	AVG	30.2	<u>32.6</u>	7.3	7.3	37.5	<u>39.9</u>	54.0	16.5	<u>14.1</u>	
3	2560.45	PEK	40.0	40.6	7.5	7.5	47.5	48.1	74.0	26.5	25.9	
4	2560.45	AVG	31.2	<u>32.1</u>	7.5	7.5	38.7	<u>39.6</u>	54.0	15.3	<u>14.4</u>	
5	2651.35	PEK	<u>40.6</u>	40.3	7.9	7.9	<u>48.5</u>	48.2	74.0	<u>25.5</u>	25.8	
6	2651.35	AVG	<u>32.7</u>	31.1	7.9	7.9	<u>40.6</u>	39.0	54.0	<u>13.4</u>	15.0	
7	2855.30	PEK	<u>40.0</u>	39.4	8.4	8.4	<u>48.4</u>	47.8	74.0	<u>25.6</u>	26.2	
8	2855.30	AVG	<u>32.0</u>	29.9	8.4	8.4	<u>40.4</u>	38.3	54.0	<u>13.6</u>	15.7	

Higher six points are underlined.
 Emission Level = Read + Factor(Antenna, Antenna Pad, Cable, Preamp)
 ANT. : Used antenna(BBA = Broadband antenna, DIP = Dipole antenna)
 (Factor = Ant.Fact. + Cable Loss - Amp.Gain + Att. - Dist.Conversion Fact.)

emiT 3, 0, 0, 0

Copyright(c)2007 Intertek Japan K.K.

**9.1.2.12 RX mode(523.995MHz : Band B)
 30 – 1000 MHz**

Intertek Japan K.K.

Tochigi No.3 Test Site

Radiated Electric Field

APPLICANT : JVCKENWOOD Corporation
 EUT NAME : 144/220/430MHz TRIBANDER
 MODEL NO. : TH-D74A
 SERIAL NO. : FES2 K-08
 TEST MODE : RX mode(523.995MHz;Band B)
 POWER SOURCE : DC13.8V(AC120 V, 60 Hz)
 DATE TESTED : May 31 2016
 FILE NO. : -
 REGULATION : FCC Part15B Class B
 TEST METHOD : ANSI C63.4-2014
 DISTANCE : 3.00 [m]
 TEMPERATURE : 25.7 [degC]
 HUMIDITY : 48.0 [%]
 NOTE :

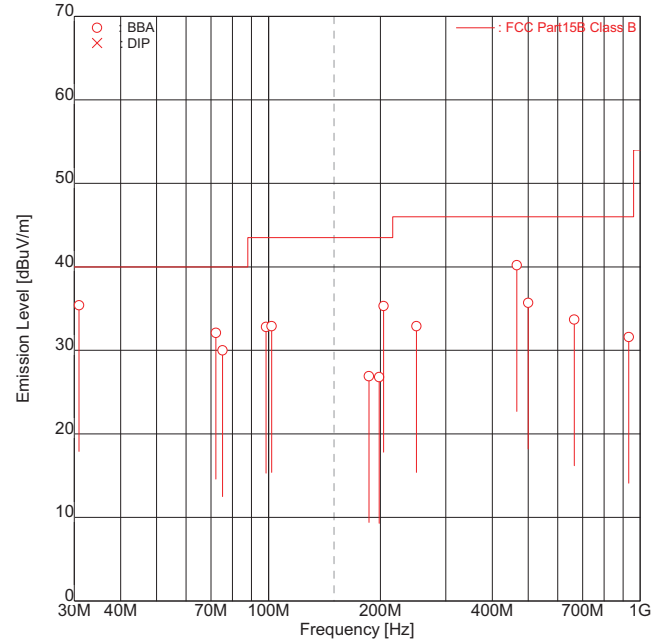

ENGINEER : Koichi Wagatsuma

FREQUENCY [No]	FREQ [MHz]	ANT.	READING [dBuV]		FACTOR [dB/m]		EMISSION [dBuV/m]		LIMIT [dBuV/m]		MARGIN [dB]	
			Hori	Vert	Hori	Vert	Hori	Vert	Hori	Vert	Hori	Vert
1	30.90	BBA	-	<u>42.6</u>	-7.2	-7.2	-	<u>35.4</u>	40.0	-	-	<u>4.6</u>
2	72.22	BBA	<u>39.4</u>	-	-7.3	-7.3	<u>32.1</u>	-	40.0	-	<u>7.9</u>	-
3	75.23	BBA	<u>38.0</u>	-	-8.0	-8.0	<u>30.0</u>	-	40.0	-	<u>10.0</u>	-
4	98.47	BBA	-	42.3	-9.5	-9.5	-	32.8	43.5	-	-	10.7
5	101.91	BBA	-	42.0	-9.1	-9.1	-	32.9	43.5	-	-	10.6
6	186.38	BBA	29.0	33.0	-6.1	-6.1	22.9	26.9	43.5	20.6	16.6	16.6
7	198.64	BBA	33.8	-	-7.0	-7.0	26.8	-	43.5	16.7	-	-
8	204.03	BBA	<u>42.2</u>	37.7	-6.9	-6.9	<u>35.3</u>	30.8	43.5	<u>8.2</u>	12.7	-
9	250.00	BBA	37.8	-	-4.9	-4.9	32.9	-	46.0	13.1	-	-
10	465.94	BBA	<u>37.8</u>	36.0	2.4	2.4	<u>40.2</u>	38.4	46.0	<u>5.8</u>	7.6	-
11	500.00	BBA	<u>32.3</u>	-	3.4	3.4	<u>35.7</u>	-	46.0	<u>10.3</u>	-	-
12	665.08	BBA	-	26.3	7.4	7.4	-	33.7	46.0	-	-	12.3
13	931.89	BBA	-	19.6	12.0	12.0	-	31.6	46.0	-	-	14.4

Higher six points are underlined.
 Other frequencies : Below the FCC Part15B Class B limit
 Emission Level = Read + Factor(Antenna,Antenna Pad,Cable,Preamp)
 ANT. : Used antenna(BBA = Broadband antenna, DIP = Dipole antenna)
 (Factor = Ant. Fact. + Cable Loss - Amp. Gain + Att. - Dist. Conversion Fact.)

emiT 3, 0, 0, 0

Copyright(c)2007 Intertek Japan K.K.

1000 – 25000 MHz

Intertek Japan K.K.

Tochigi No.1 Test Site

Radiated Electric Field

APPLICANT : JVCKENWOOD Corporation
 EUT NAME : 144/220/430MHz TRIBANDER
 MODEL NO. : TH-D74A
 SERIAL NO. : FES2 K-08
 TEST MODE : RX mode(523.995MHz: Band B)
 POWER SOURCE : DC 13.8V (AC120 V, 60 Hz)
 DATE TESTED : Jun 07 2016
 FILE NO. : -
 REGULATION : FCC Part15B Class B
 TEST METHOD : ANSI C63.4-2014
 DISTANCE : 3.73 [m]
 TEMPERATURE : 21.6 [degC]
 HUMIDITY : 65.0 [%]
 NOTE :

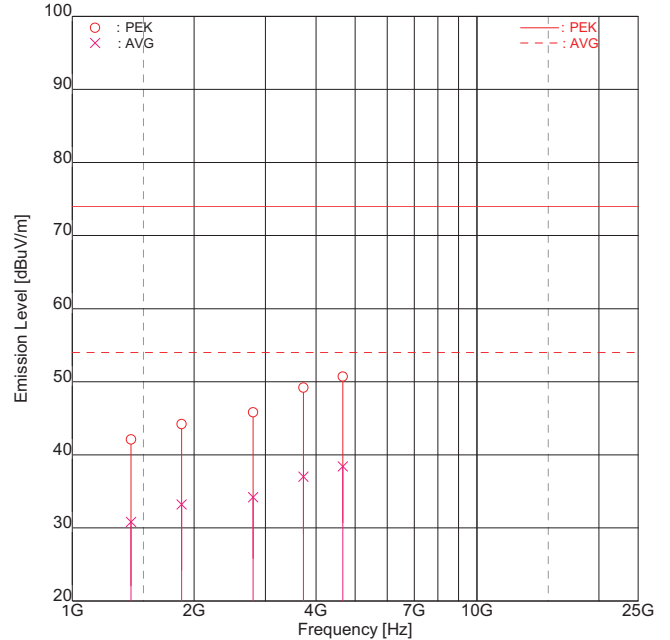

ENGINEER : Koichi Wagatuma

FREQUENCY [No]	MODE [MHz]	READING [dBuV]		FACTOR [dB]		EMISSION [dBuV/m]		LIMIT [dBuV/m]	MARGIN [dB]		
		Hori	Vert	Hori	Vert	Hori	Vert		Hori	Vert	
1	1397.84	PEK	38.0	39.5	2.6	2.6	40.6	42.1	74.0	33.4	31.9
2	1397.84	AVG	26.5	<u>28.2</u>	2.6	2.6	29.1	<u>30.8</u>	54.0	24.9	<u>23.2</u>
3	1863.78	PEK	39.0	-	5.2	5.2	44.2	-	74.0	29.8	-
4	1863.78	AVG	<u>28.0</u>	-	5.2	5.2	<u>33.2</u>	-	54.0	<u>20.8</u>	-
5	2798.67	PEK	37.3	37.5	8.3	8.3	45.6	45.8	74.0	28.4	28.2
6	2798.67	AVG	25.7	<u>25.9</u>	8.3	8.3	34.0	<u>34.2</u>	54.0	20.0	<u>19.8</u>
7	3727.56	PEK	37.5	38.0	11.2	11.2	48.7	49.2	74.0	25.3	24.8
8	3727.56	AVG	<u>25.8</u>	25.7	11.2	11.2	<u>37.0</u>	36.9	54.0	<u>17.0</u>	17.1
9	4659.45	PEK	37.5	<u>38.1</u>	12.6	12.6	50.1	<u>50.7</u>	74.0	23.9	<u>23.3</u>
10	4659.45	AVG	25.7	<u>25.8</u>	12.6	12.6	38.3	<u>38.4</u>	54.0	15.7	<u>15.6</u>

Higher six points are underlined.
 Emission Level = Read + Factor(Antenna, Antenna Pad, Cable, Preamp)
 ANT. : Used antenna (BBA = Broadband antenna, DIP = Dipole antenna)
 (Factor = Ant. Fact. + Cable Loss - Amp. Gain + Att. - Dist. Conversion Fact.)

emiT 3, 0, 0, 0

Copyright(c)2007 Intertek Japan K.K.

SECTION 10. LIST OF MEASURING INSTRUMENTS

Test instruments are calibrated according to Quality Manual and Calibration Rules of Intertek Japan K.K.
 All measurements equipment used for the measurement is calibrated based on standard.
 Each measurement result is traceable to national or international standards.
 Antenna used for the measurement is calibrated based on the ANSI C63.5.

Instrument	Model No.	Serial No.	Manufacturer	Cal. Interval	Effective period
Conducted disturbance at mains terminals					
LISN (EUT)	ESH2-Z5	890484/005	Rohde & Schwarz	1 Y	Jul., 31 2016
10dB Attenuator	CFA-01(BPJ-10)	None(F0300008)	TAMAGAWA	1 Y	Jul., 31 2016
LISN (Peripheral)	KNW-407	8-1395-6	Kyoritsu	1 Y	Nov.30, 2016
10dB Attenuator	CFA-01(BPJ-10)	None(F0300009)	TAMAGAWA	1 Y	Nov.30, 2016
50Ω Termination	CT-01	None(F03050013)	TAMAGAWA	1 Y	Nov.30, 2016
Coaxial cable(C1)	5D-2W(4.6 m)	3C01a	Intertek	1 Y	Nov.30, 2016
Coaxial cable(C2)	RG-5A/U(9.0 m)	3C02	Intertek	1 Y	Nov.30, 2016
Coaxial cable(C3)	5D-2W(0.2 m)	3C03	Intertek	1 Y	Nov.30, 2016
Coaxial cable(C4)	5D-2W(1.7 m)	3C04a	Intertek	1 Y	Nov.30, 2016
RF Switch	ACX-150	None(F03301501)	Intertek	1 Y	Nov.30, 2016
Radiated disturbance					
Broad Band antenna	VULB9168	218	Schwarzbeck	1 Y	Mar.31 2017
6dB Attenuator	CFA-01(NPJ-6)	None(F0300002)	TAMAGAWA	1 Y	Apr.31 2017
Step Attenuator	8494B	2812A15595	Hewlett Packard	1 Y	May 31 2017
Amplifier	8447D	1937A03130	Hewlett Packard	1 Y	May 31 2017
Coaxial cable(R1)	5D-2W(12.0 m)	3R01a	Intertek	1 Y	May 31 2017
Coaxial cable(R2)	10D-2W(21.0 m)	3R02a	Intertek	1 Y	May 31 2017
Coaxial cable(R3)	RG-5A/U(0.2 m)	3R03	Intertek	1 Y	May 31 2017
Coaxial cable(R4)	5D-2W(0.7 m)	3R04	Intertek	1 Y	May 31 2017
Coaxial cable(R5)	5D-2W(0.2 m)	3R05	Intertek	1 Y	May 31 2017
Coaxial cable(R6)	5D-2W(1.7 m)	3R06a	Intertek	1 Y	May 31 2017
RF Switch	ACX-150	None(F03301501)	Intertek	1 Y	May 31 2017
Site Attenuation				1 Y	Dec. 31 2016
Double ridged antenna	3115	9903-5699	EMCO	1 Y	Jul 31 2016
6dB Attenuator	8493C	80390	Agilent	1 Y	Nov.30 2016
Amplifier	TPA0118-30	1052071(0504)	TOYO	1 Y	Nov.30 2016
Coaxial cable(RG1)	SUCOFLEX(1.5 m)	MY19475/4	SUHNER	1 Y	Nov.30 2016
Coaxial cable(RG2)	SUCOFLEX(6.0 m)	MY19494/4	SUHNER	1 Y	Nov.30 2016
Spectrum analyzer	8563E (Firmware Revision 71024)	3821A09565	Hewlett Packard	1 Y	May.31 2017
Double Ridged Antenna	MLA-18265-B03-30	1694440	TSJ	1 Y	Feb.28 2017
Coaxial Cable(RG3)	5B-048-98-98-6000	120315	Candox	1 Y	Sep.30 2016
SVSWR				1 Y	Jun.30, 2016
Common					
Test receiver	ESS (Firmware Version 1.07)	842886/013	Rohde & Schwarz	1 Y	Jan.31, 2017
Testing Software	emiT (Version 3,0,0,0)				

ANNEX

A. TEST PROCEDURE(S)

Test was carried out under the following conditions.

Conducted disturbance at mains terminals

Test setup as per standard

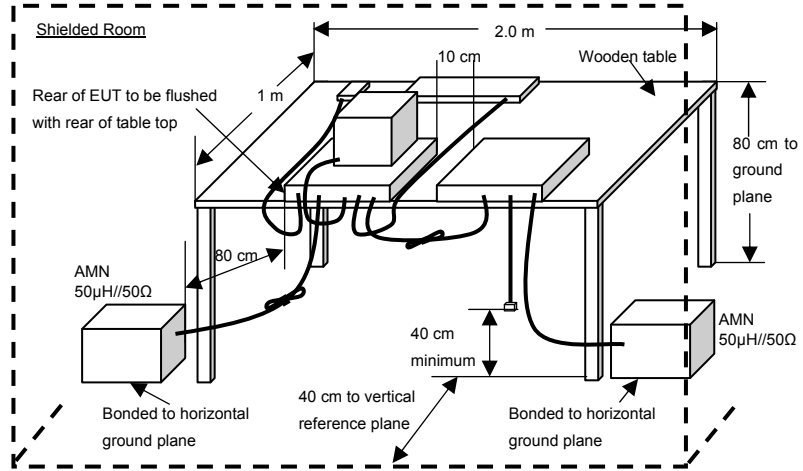

* Reference Ground plane : greater than 2 x 2m

Diagram of the measuring instruments

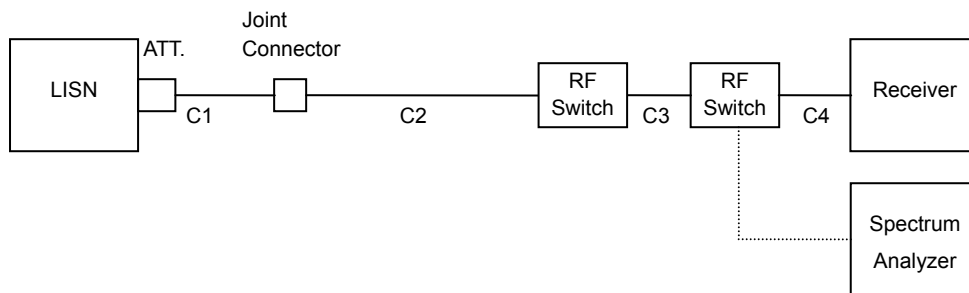

[Preliminary Measurement]

EUT is tested on all operating conditions.

The spectrum analyzer is controlled by the computer program to sweep the frequency range to be measured, then spectrum chart is plotted out to find the worst emission conditions in operating mode and/or configuration decision for the final test.

All leads other than safety ground are tested.

[Final Measurement]

The EUT is operated in the worst emission condition found by the preliminary test.

The equipment and cables are arranged or manipulated within the range of the test standard in the above condition.

At least six highest spectrum are measured in quasi-peak and average (if necessary) using the test receiver.

Radiated disturbance
Test setup as per standard

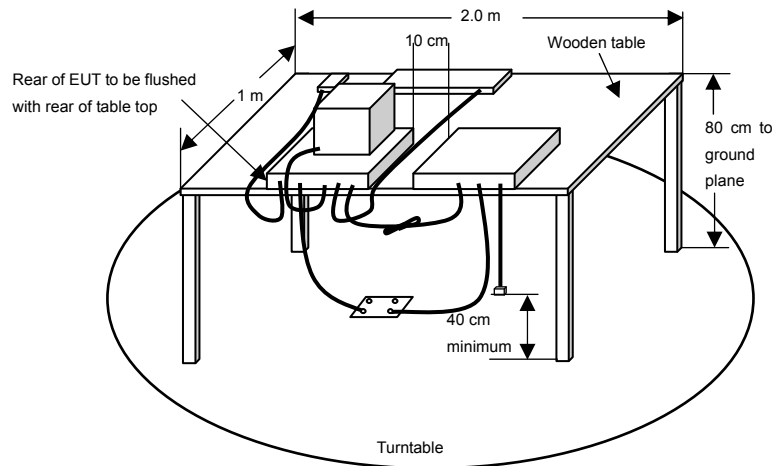
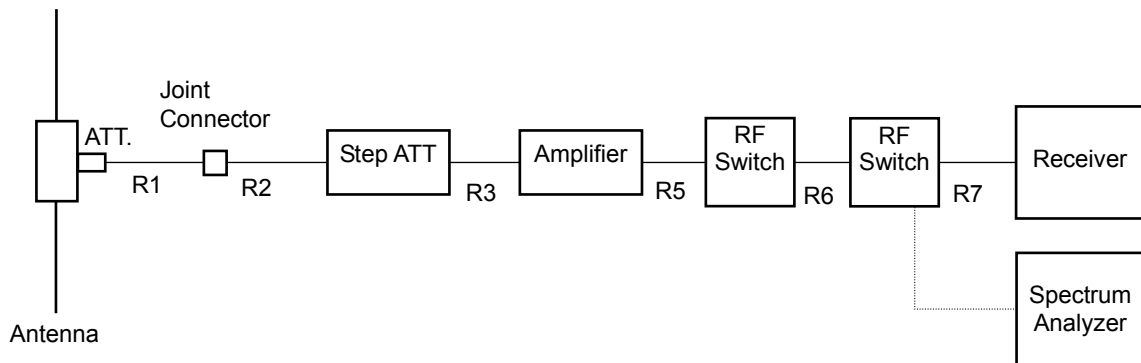
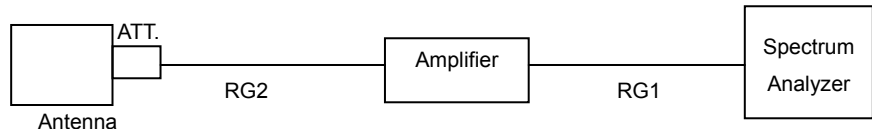

Diagram of the measuring instruments (30-1000MHz)



Above 1GHz(1-18GHz)



Above 1GHz(18-26.5GHz)



[Preliminary Measurement]

EUT is tested on all operating conditions.
 The spectrum analyzer is set max-hold mode and swept during turntable was rotated 0 to 360 degree,
 And find the worst emission conditions in configuration, operating mode, or ambient noise notation.

[Final Measurement]

The EUT operated in the worst emission condition found by the preliminary test.
 The turntable azimuth (EUT direction) and antenna height are adjusted the position so that maximum field strength is obtained for each frequency spectrum to be measured.
 The equipment and cables are arranged or manipulated within the range of the test standard in the above condition. At least six highest spectrums are measured by the test receiver (quasi-peak) and spectrum analyzer (peak and average). When the uncertain result was obtained (30 – 1000 MHz), the measurement is retried by using the half wave dipole antenna instead of the broadband antenna.