

# REPORT

## FCC Permissive change

**Applicant Name:**  
JVC KENWOOD Corporation

**Address:**  
1-16-2, Hakusan, Midori-ku, Yokohama-shi, Kanagawa,  
226-8525 Japan

**Date of Issue:**

August 10, 2016

**Test Site/Location:**

HCT CO., LTD., 74, Seoicheon-ro 578beon-gil, Majang-  
myeo, Icheon-si, Gyeonggi-do, 17383, Rep. of KOREA

**Report No.:** HCT-R-1607-F027-1

**HCT FRN:** 0005866421

**FCC ID** : K44431500

**APPLICANT** : JVC KENWOOD Corporation

**FCC Model(s):** NX-5300-K2, NX-5300-K3, NX-5300-F2, NX-5300-F3

**EUT Type:** UHF P25 TRANCEIVER WITH BLUETOOTH

**Frequency Range:** 450 – 512 MHz

**FCC Rule Part(s):** Part 90 and Part 2

**Engineering Statement:**

The measurements shown in this report were made in accordance with the procedures indicated, and the emissions from this equipment were found to be within the limits applicable. I assume full responsibility for the accuracy and completeness of these measurements, and for the qualifications of all persons taking them.

HCT CO., LTD. Certifies that no party to this application has subject to a denial of Federal benefits that includes FCC benefits pursuant to section 5301 of the Anti-Drug Abuse Act of 1998, 21 U.S. C.853(a)



**Report prepared by**  
: Seoul Ki Lee

**Test Engineer of RF Team**



**Approved by**  
: Jong Seok Lee

**Manager of RF Team**

This report only responds to the tested sample and may not be reproduced, except in full, without written approval of the HCT Co.,

## Version

TEST REPORT NO.	DATE	DESCRIPTION
HCT-R-1607-F027	July 29, 2016	- First Approval Report
HCT-R-1607-F027-1	August 10, 2016	- Add the Limit for Emission Mask on Page 15 - Add the Information for Type of Emission on Page 6

## Table of Contents

1. GENERAL INFORMATION .....	4
2. EUT DESCRIPTION .....	4
3. TEST METHODOLOGY .....	5
3.1 EUT CONFIGURATION .....	5
3.2 EUT EXERCISE .....	5
3.3 GENERAL TEST PROCEDURES .....	5
3.4 DESCRIPTION OF TEST MODES .....	5
3.5 Type of Emission(Necessary Bandwidth Calculations) .....	6
4. INSTRUMENT CALIBRATION.....	6
5. FACILITIES AND ACCREDITATIONS .....	6
5.1 FACILITIES .....	6
5.2 EQUIPMENT .....	6
6. SUMMARY TEST OF RESULTS .....	7
7. TEST RESULT .....	8
7.1 Carrier Output Power .....	8
7.2 Occupied Bandwidth.....	9
7.3 Emission Mask.....	14
7.4 Unwanted Emissions : Conducted Spurious Emission .....	19
7.5 Unwanted Emissions : Radiated Spurious Emission.....	28
8. LIST OF TEST EQUIPMENT .....	32
8.1 LIST OF TEST EQUIPMENT(Conducted Test) .....	32
8.2 LIST OF TEST EQUIPMENT(Radiated Test).....	33

## 1. GENERAL INFORMATION

<b>Applicant:</b>	JVC KENWOOD Corporation
<b>Address:</b>	1-16-2, Hakusan, Midori-ku, Yokohama-shi, Kanagawa, 226-8525 Japan
<b>FCC ID:</b>	K44431500
<b>EUT Type:</b>	UHF P25 TRANCEIVER WITH BLUETOOTH
<b>Model name(s):</b>	NX-5300-K2, NX-5300-K3, NX-5300-F2, NX-5300-F3
<b>Date(s) of Tests:</b>	July 01, 2016 ~ July 26, 2016
<b>Place of Tests:</b>	HCT Co., Ltd. 74, Seoicheon-ro 578beon-gil, Majang-myeo, Icheon-si, Gyeonggi-do, 17383, Rep. of KOREA

## 2. EUT DESCRIPTION

<b>EUT Type</b>	UHF P25 TRANCEIVER WITH BLUETOOTH
<b>FCC Model Name</b>	NX-5300-K2, NX-5300-K3, NX-5300-F2, NX-5300-F3
<b>Power Supply</b>	DC 7.5 V
<b>Output Power</b>	5 W (Power output continuously variable to 1 W)
<b>Battery type</b>	Li-ion Battery (EX-4621/ EX-4622/ EX-4623)
<b>Channel Bandwidth</b>	12.5 kHz
<b>Operating Temperature</b>	-30 °C ~ +60 °C
<b>Frequency Range</b>	450 – 512 MHz

### 3. TEST METHODOLOGY

TIA-603-D dated June 24, 2010 entitled “Land Mobile FM or PM Communications Equipment Measurement and Performance Standards” were used in the measurement.

#### 3.1 EUT CONFIGURATION

The EUT configuration for testing is installed on RF field strength measurement to meet the Commissions requirement and operating in a manner that intends to maximize its emission characteristics in a continuous normal application.

#### 3.2 EUT EXERCISE

The EUT was operated in the engineering mode to fix the Tx frequency that was for the purpose of the measurements. According to its specifications, the EUT must comply with the requirements of the FCC Rules Part 2 and Part 90.

#### 3.3 GENERAL TEST PROCEDURES

##### Radiated Emissions

Radiated emission measurements are performed in the Fully-anechoic chamber. The equipment under test is placed on a non-conductive table 3-meters away from the receive antenna in accordance with ANSI/TIA-603-D-2010 Clause 2.2.17. The turntable is rotated through 360 degrees, and the receiving antenna scans in order to determine the level of the maximized emission. The level and position of the maximized emission is recorded with the spectrum analyzer using a positive peak detector.

A half wave dipole is then substituted in place of the EUT. For emissions above 1GHz, a horn antenna is substituted in place of the EUT. The substitute antenna is driven by a signal generator and the previously recorded signal was duplicated.

The power is calculated by the following formula;

$$P_{d(\text{dBm})} = P_{g(\text{dBm})} - \text{cable loss (dB)} + \text{antenna gain (dB)}$$

Where:  $P_d$  is the dipole equivalent power and  $P_g$  is the generator output power into the substitution antenna.

The maximum EIRP is calculated by adding the forward power to the calibrated source plus its appropriate gain value. These steps are repeated with the receiving antenna in both vertical and horizontal polarization. the difference between the gain of the horn and an isotropic antenna are taken into consideration

#### 3.4 DESCRIPTION OF TEST MODES

The EUT has been tested under operating condition. Test program used to control the EUT for staying in continuous transmitting is programmed.

### 3.5 Type of Emission(Necessary Bandwidth Calculations)

7K60FXD, 7K60FXE (DMR)

Modulation = 7K60FXD, 7K60FXE	
Digital information rate (R), bps	9600
Maximum Deviation (D), kHz	3.024
Signaling States (S)	4
Constant Factor (K)	0.463
Necessary Bandwidth (BN), kHz	$(R/\log_2S)+2DK$
Necessary Bandwidth (BN), kHz	7.6

Note :

Type of modulation of the main carrier : F = Frequency Modulation

Nature of signals modulating the main carrier : X = Cases not otherwise covered

Type of information to be transmitted : E = Telephony(including sound broadcasting)

D = Data transmission, telemetry, telecommand

## 4. INSTRUMENT CALIBRATION

The measuring equipment, which was utilized in performing the tests documented herein, has been calibrated in accordance with the manufacturer's recommendations for utilizing calibration equipments, which is traceable to recognized national standards.

## 5. FACILITIES AND ACCREDITATIONS

### 5.1 FACILITIES

The Fully-anechoic chamber and conducted measurement facility used to collect the radiated data are located at the 74, Seoicheon-ro 578beon-gil, Majang-myeon, Icheon-si, Gyeonggi-do, Korea.

### 5.2 EQUIPMENT

Radiated emissions are measured with one or more of the following types of Linearly polarized antennas: tuned dipole, bi-conical, log periodic, bi-log, and/or ridged waveguide, horn. Spectrum analyzers with pre-selectors and quasi-peak detectors are used to perform radiated measurements. Conducted emissions are measured with Line Impedance Stabilization Networks and EMI Test Receivers. Calibrated wideband preamplifiers, coaxial cables, and coaxial attenuators are also used for making measurements.

All receiving equipment conforms to CISPR Publication 16-1, "Radio Interference Measuring Apparatus and Measurement Methods."

## 6. SUMMARY TEST OF RESULTS

Test Description	FCC Part Section(s)	IC Part Section(s)	Test Limit	Test Condition	Test Result
Carrier RF Output Power	§90.205(i) §2.1046(a)	RSS119-i12(5.4)	Varies	CONDUCTED	PASS
Unwanted Emissions	§2.1051	RSS119-i12(5.8)			PASS
99% Bandwidth(IC)	NA	NA	NA		PASS
Emission Mask	§90.210, §2.1049( c)(1)	RSS119-i12(5.5)	Varies		PASS
Field Strength of Spurious Radiation	§2.1053	RSS119-i12(5.8)	Varies	RADIATED	PASS
Receiver Spurious Emissions	§15.109(a)	RSS-Gen-i4	cf. Section 7.10		PASS

## 7. TEST RESULT

### 7.1 Carrier Output Power

#### ■ Definition

The conducted carrier power output rating for a transmitter is the power available at the output terminals of the transmitter when the output terminals are connected to the standard transmitter load.

#### ■ TEST CONFIGURATION

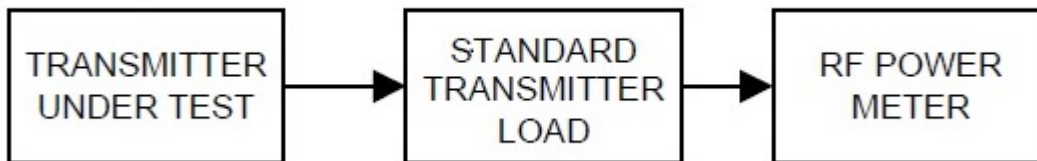

#### ■ TEST PROCEDURE

According to 2.2.1 in TIA-603-D Standard.

- a) Connect the equipment as illustrated.
- b) Measure the transmitter output power during the defined duty cycle(see 1.3.2).  
Correct for all losses in the RF path.
- c) The value recorded in step b) is the conducted carrier output power rating.

#### ■ TEST RESULTS

Mode	Type of Emission	Channel Spacing	Freq.(MHz)	Carrier Output Power			
				Low		High	
				dBm	W	dBm	W
Digital	7K60FXD, 7K60FXE	12.5 kHz	450.05	29.298	0.851	36.919	4.919
			481.05	29.739	0.942	36.802	4.789
			511.95	29.758	0.946	36.951	4.956



## 7.2 Occupied Bandwidth

### ■ Definition

The transmitter sideband spectrum denotes the sideband power produced at a discrete frequency separation from the carrier up to the test bandwidth (see TIA-603-D Section 1.3.4.4) due to all sources of unwanted noise within the transmitter in a modulated condition.

### ■ TEST CONFIGURATION

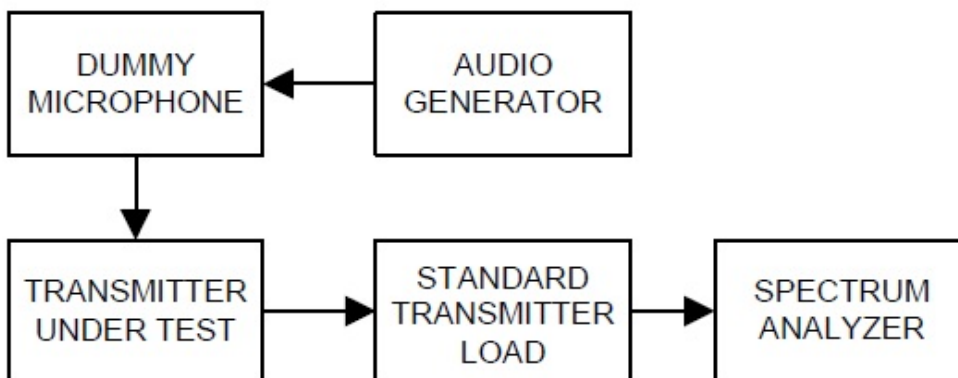

### ■ TEST PROCEDURE

According to TIA-603-D Section 2.2.11.2 / RSS-119 Section 5.5

- a) For EUT supporting audio modulation, the audio signal generator was adjusted to the frequency of maximum response and with output level set for +/- 2.5 kHz deviation (or 50 % modulation). (FM modulation).
- b) With level constant, the signal level was increased 16 dB..
- c) For EUT supporting digital modulation, the digital modulation mode was operated to its maximum extent.
- d) Adjust the spectrum analyzer for the following setting:
  - 1) RBW : 100Hz (Authorized Band 6 kHz),  
100Hz (Authorized Band 11.25 kHz),  
300Hz (Authorized Band 20 kHz)
  - 2) VBW : Video Bandwidth at least 10 times the resolution bandwidth.
  - 4) Sweep Speed : Sweep Speed slow enough to maintain measurement calibration.
  - 5) Sampling Time : 10 times
  - 6) Detector Mode = Positive Peak.
- e) The occupied Bandwidth was measured with the Spectrum Analyzer controls set as shown on the test results.

■ **LIMIT**

Frequency Band (MHz)	Channel bandwidth (kHz)	Authorized Bandwidth (kHz)
450 - 512	12.5	11.25

■ **TEST RESULTS**

Conducted 99% Bandwidth Measurements for 7K60FXD, 7K60FXE

11K0F3E Mode		Measured Bandwidth [kHz]	Setting
Frequency [MHz]	Channel bandwidth		
450.05	12.5 kHz	7.446	High Power
481.05		7.437	
511.95		7.445	
450.05	12.5 kHz	7.469	Low Power
481.05		7.438	
511.95		7.459	

■ Plots of 99% Bandwidth

450.05 MHz\_High

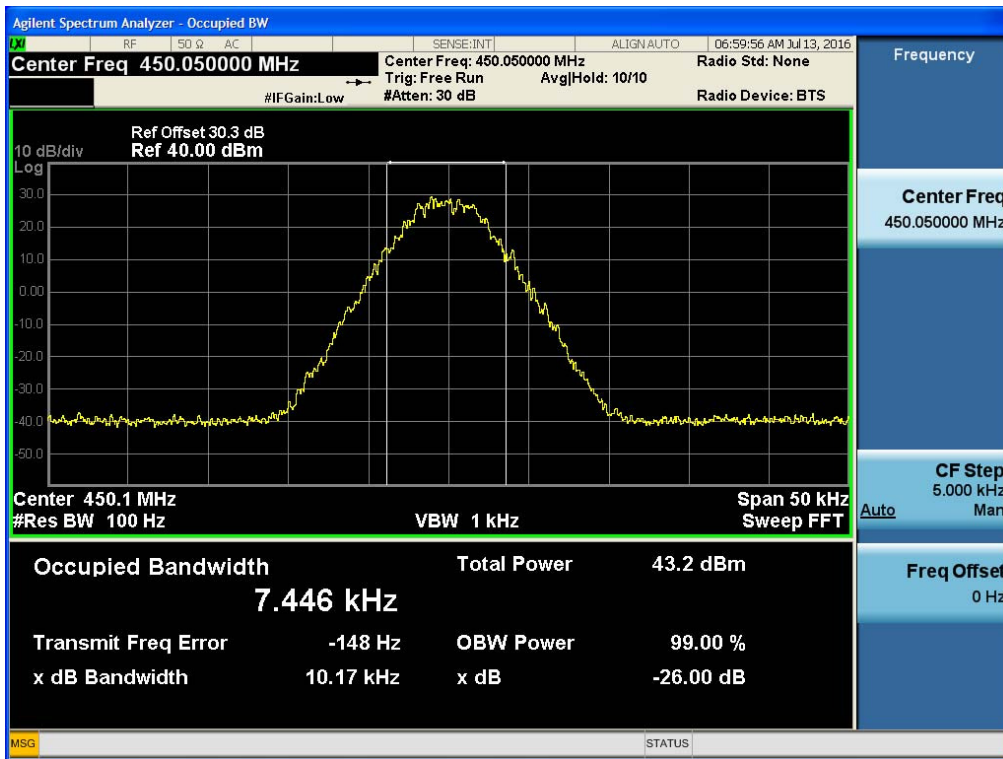

481.05 MHz\_High

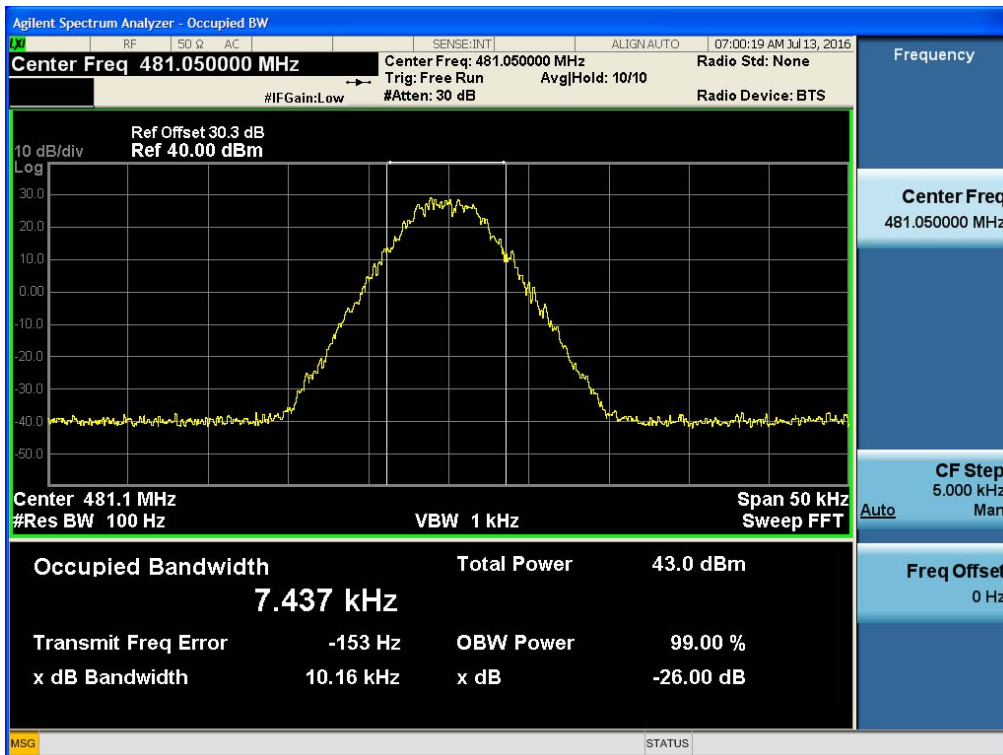

511.95 MHz\_High

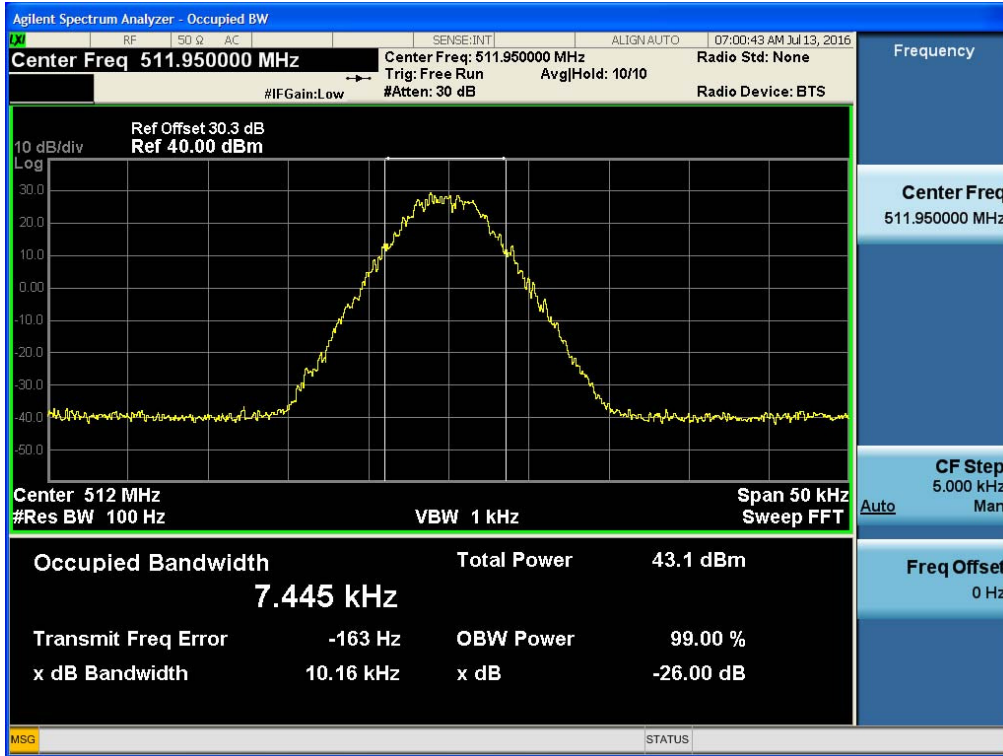

450.05 MHz\_Low

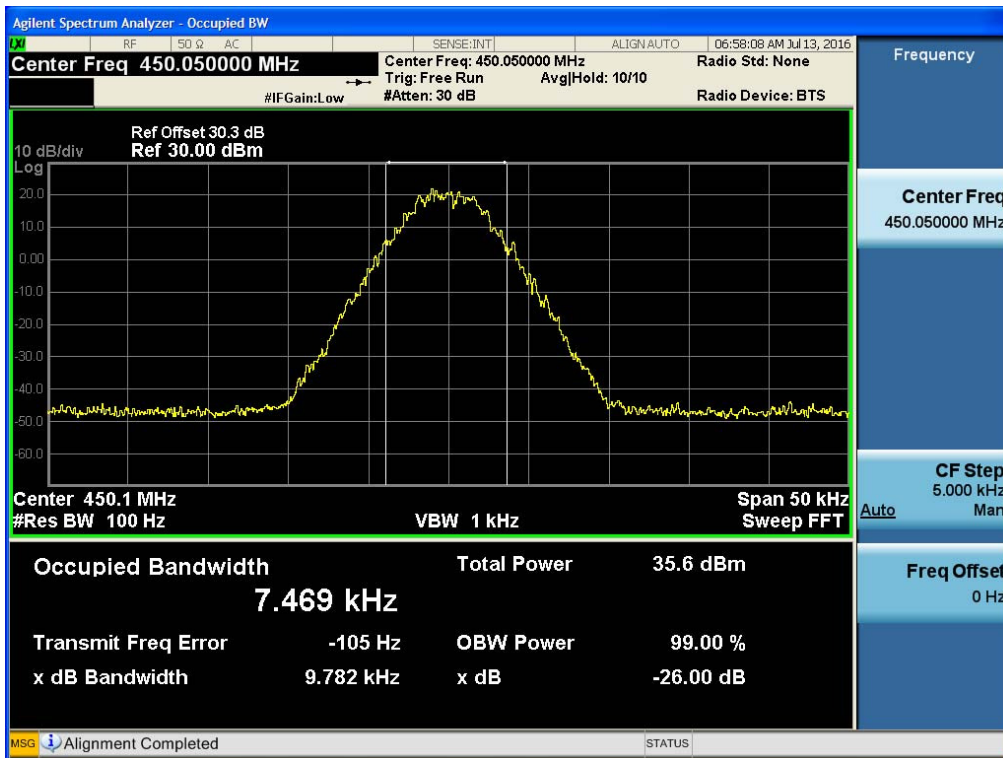

481.05 MHz\_Low

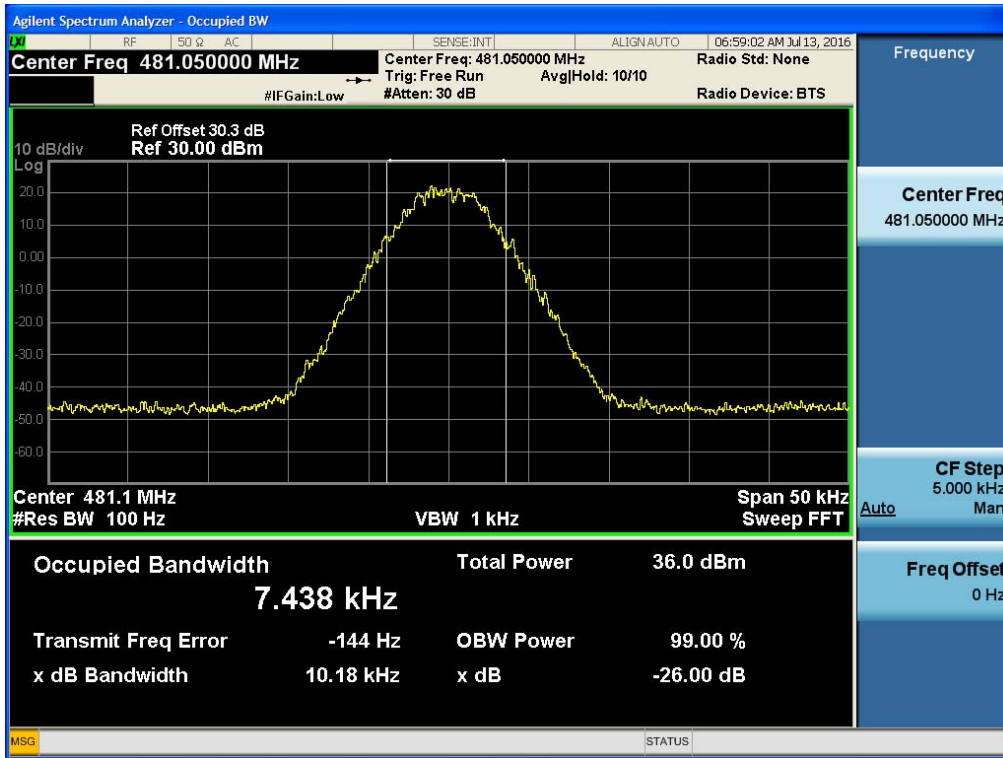

511.95 MHz\_Low

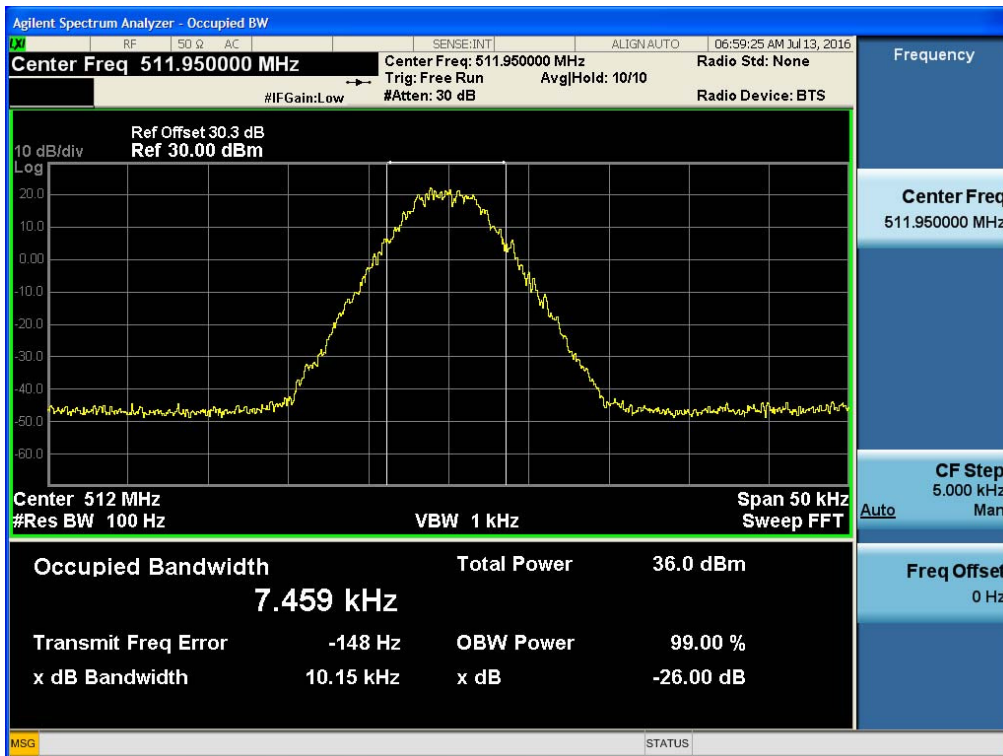

### 7.3 Emission Mask

■ **Definition**

The transmitter Emission Mask denotes the sideband power produced at a discrete frequency separation from the carrier up to the test bandwidth (see 1.3.4.4) due to all sources of unwanted noise within the transmitter in a modulated condition.

■ **TEST CONFIGURATION**

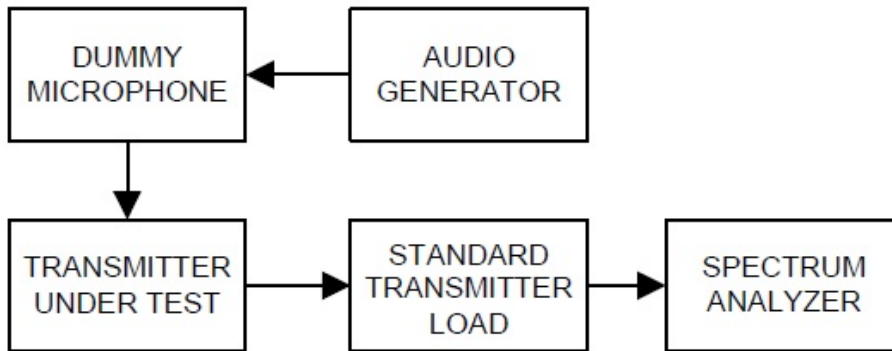

■ **TEST PROCEDURE**

According to 2.2.11 in TIA-603-D Standard.

- a) Connect the equipment as illustrated. Use the table to determine the spectrum analyzer resolution bandwidth:

Spectrum Analyzer Resolution Bandwidth

Frequency Band (MHz)	Mask for Equipment with Audio Low Pass Filter	Mask for Equipment without Low Pass Filter	Spectrum Analyzer Resolution Bandwidth (Hz)
25-50	B	C	300
72-76	B	C	300
138-174	NTIA	NTIA	300
150-174	B	C	300
150-174	D or E	D or E	100
406-420	NTIA	NTIA	300
421-512	B	C	300
421-512	D or E	D or E	100
806-821/851-866	B or EA	G or EA	300
821-824/866-869	B	H	300
896-901/935-940	I	J	300

- b) Adjust the spectrum analyzer for the following settings:
  - 1) Resolution Bandwidth per the above table
  - 2) Video Bandwidth at least 10 times the resolution bandwidth.
  - 3) Sweep Speed slow enough to maintain measurement calibration.

- 4) Detector Mode = Positive Peak.
- 5) Span that will allow proper viewing of the test bandwidth (see 1.3.4.4).
- c) Set the center frequency of the spectrum analyzer to the assigned transmitter frequency. Key the transmitter, and set the level of the unmodulated carrier to a full scale reference line. This is the 0 dB reference for the measurement.
- d) Modulate the transmitter with a 2500 Hz sine wave at an input level 16 dB greater than that necessary to produce 50% of rated system deviation. The input level shall be established at the frequency of maximum response of the audio modulating circuit. Transmitters employing digital modulation techniques that bypass the limiter and the audio low-pass filter shall be modulated as specified by the manufacturer.
- e) Record the resulting spectrum analyzer presentation of the emission level with an on-line recording device or in a photograph. It is recommended that the emission limit (as given in 3.2.11) be drawn on the plotted graph or photograph. The spectrum analyzer presentation is the sideband spectrum.

■ **Limit : Mask D**

*Emission Mask D—12.5 kHz channel bandwidth equipment.* For transmitters designed to operate with a 12.5 kHz channel bandwidth, any emission must be attenuated below the power (P) of the highest emission contained within the authorized bandwidth as follows:

- (1) On any frequency from the center of the authorized bandwidth  $f_0$  to 5.625 kHz removed from  $f_0$ : Zero dB.
- (2) On any frequency removed from the center of the authorized bandwidth by a displacement frequency ( $f_d$  in kHz) of more than 5.625 kHz but no more than 12.5 kHz: At least  $7.27(f_d - 2.88 \text{ kHz})$  dB.
- (3) On any frequency removed from the center of the authorized bandwidth by a displacement frequency ( $f_d$  in kHz) of more than 12.5 kHz: At least  $50 + 10 \log (P)$  dB or 70 dB, whichever is the lesser attenuation.
- (4) The reference level for showing compliance with the emission mask shall be established using a resolution bandwidth sufficiently wide (usually two or three times the channel bandwidth) to capture the true peak emission of the equipment under test. In order to show compliance with the emission mask up to and including 50 kHz removed from the edge of the authorized bandwidth, adjust the resolution bandwidth to 100 Hz with the measuring instrument in a peak hold mode. A sufficient number of sweeps must be measured to insure that the emission profile is developed. If video filtering is used, its bandwidth must not be less than the instrument resolution bandwidth. For emissions beyond 50 kHz from the edge of the authorized bandwidth, see paragraph (o) of this section. If it can be shown that use of the above instrumentation settings do not accurately represent the true interference potential of the equipment under test, an alternate procedure may be used provided prior Commission approval is obtained.



▣ TEST RESULTS

450.05 MHz\_HIGH POWER

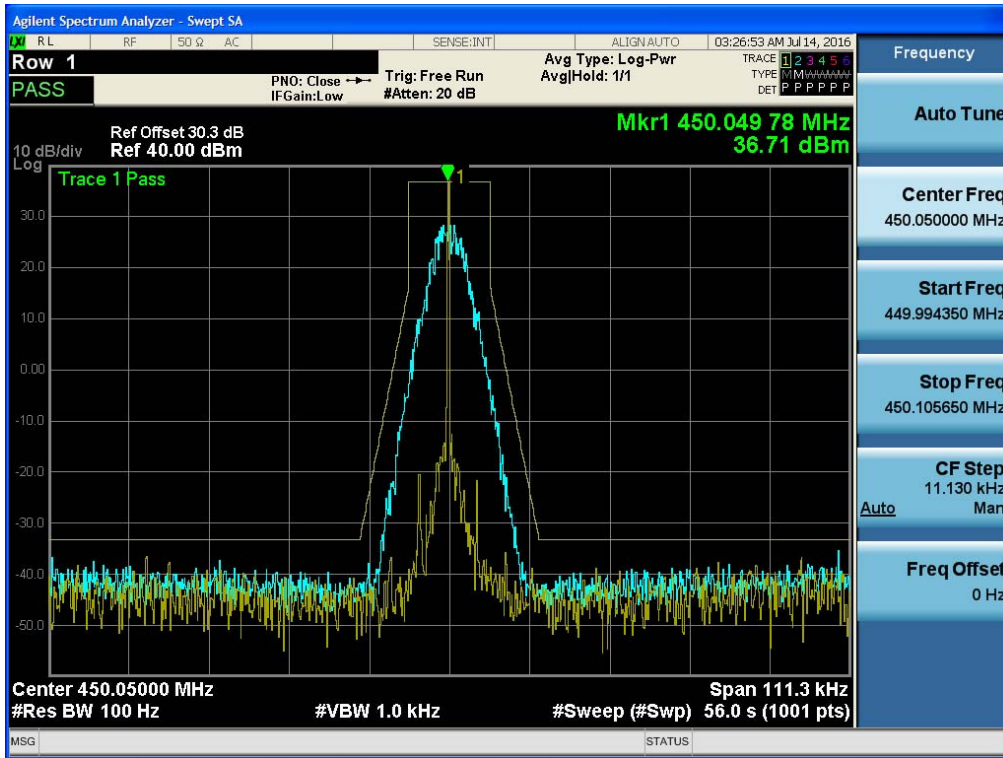

481.05 MHz\_HIGH POWER

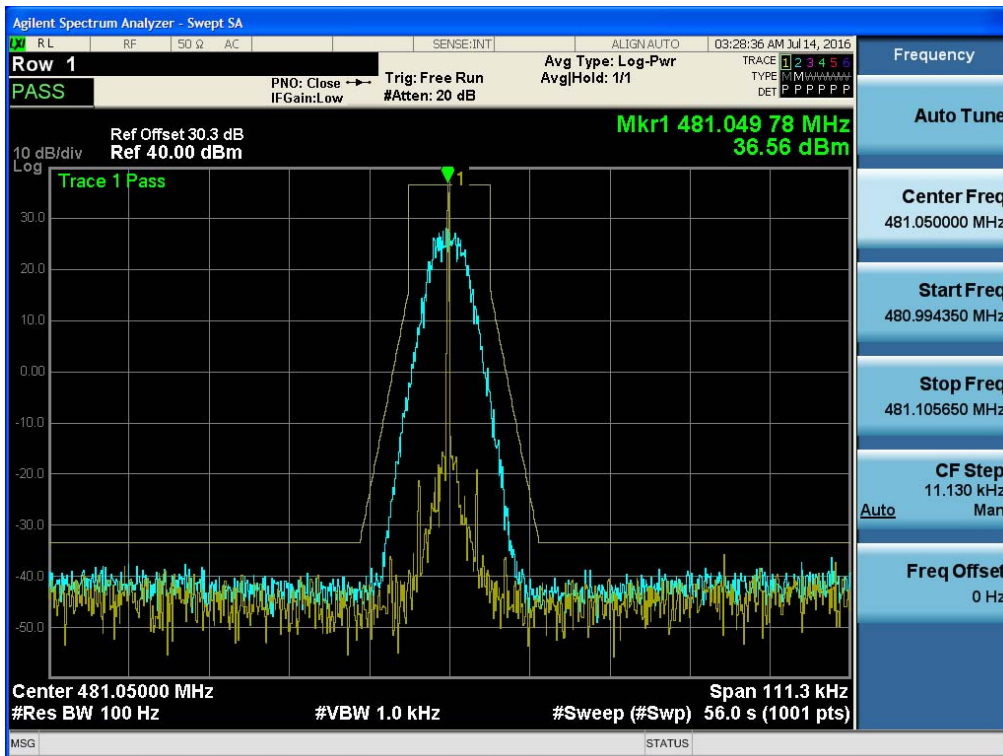



511.95 MHz\_HIGH POWER

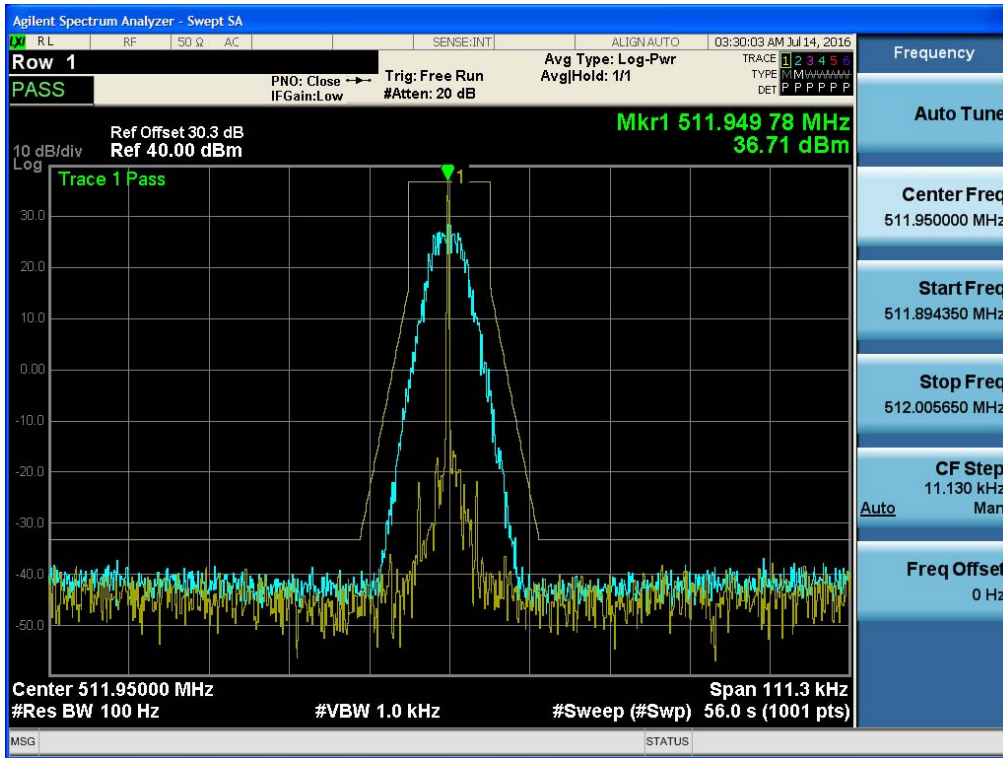

450.05 MHz\_LOW POWER

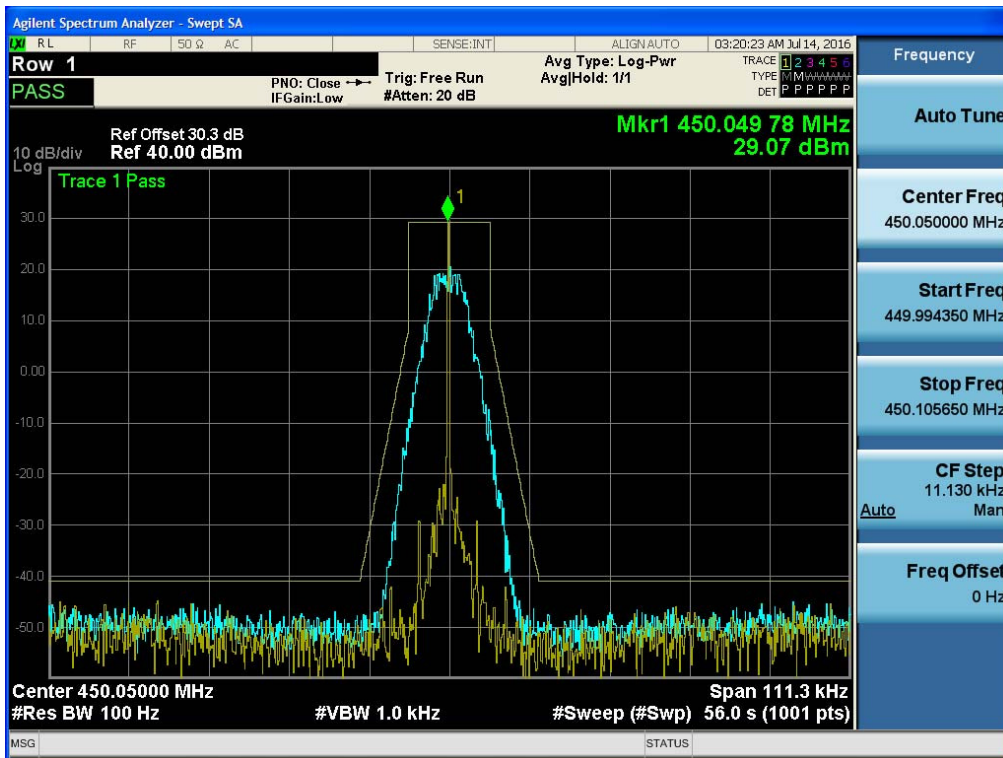

481.05 MHz\_LOW POWER

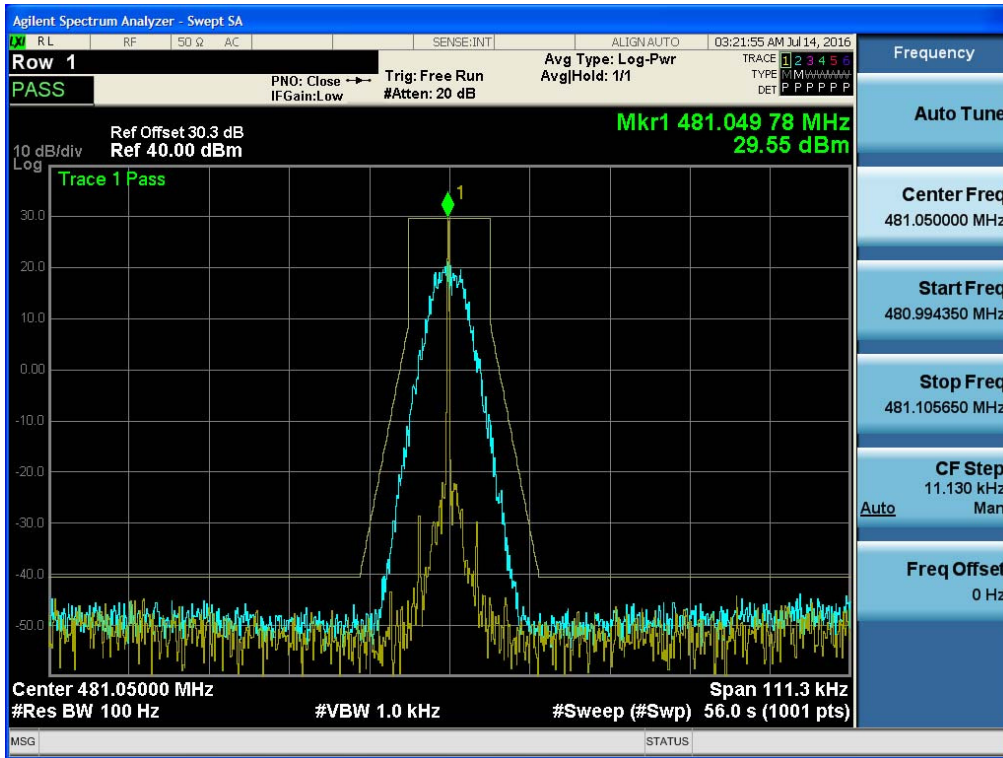

511.95 MHz\_LOW POWER

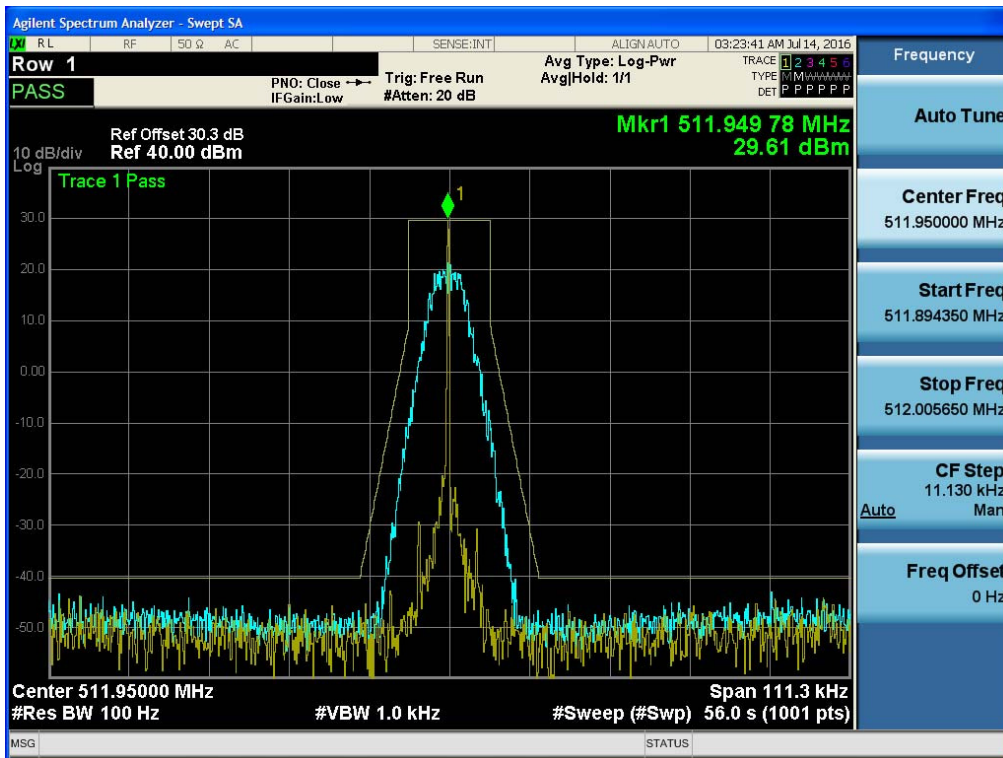

## 7.4 Unwanted Emissions : Conducted Spurious Emission

### ■ Definition

Conducted spurious emissions are emissions at the antenna terminals on a frequency or frequencies that are outside a band sufficient to ensure transmission of information of required quality for the class of communication desired.

### ■ TEST CONFIGURATION

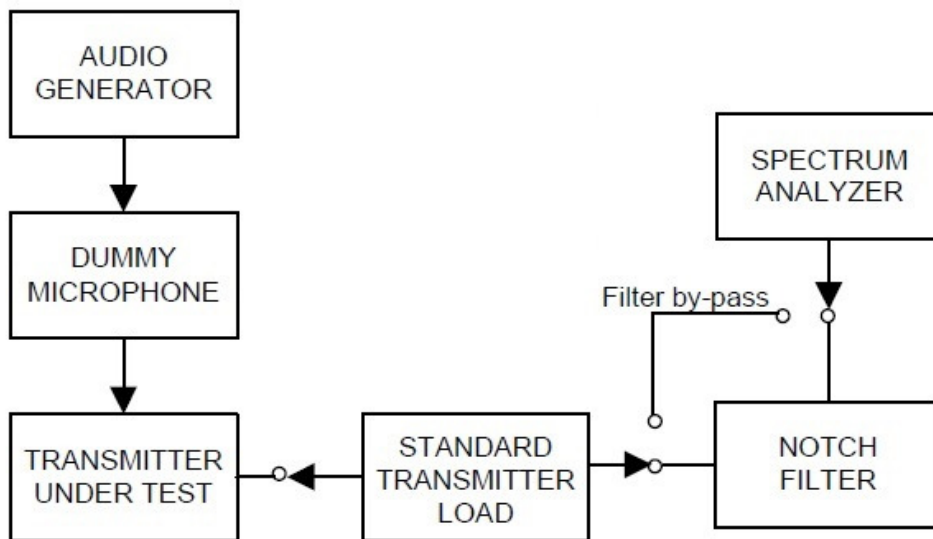

### ■ TEST PROCEDURE

According to 2.2.13 in TIA-603-D Standard.

- e) Connect the equipment as illustrated, with the notch filter by-passed.
- f) Set the center frequency of the spectrum analyzer to the assigned transmitter frequency, key the transmitter, and set the level of the carrier to the full scale reference line.
- g) Modulate the transmitter with a 2500 Hz sine wave at an input level 16 dB greater than that necessary to produce 50% of rated system deviation. The input level shall be established at the frequency of maximum response of the audio modulation circuit.
- h) Adjust the spectrum analyzer for the following settings:
  - 1) Resolution Bandwidth = 10 kHz for spurious emissions below 1 GHz, and 1 MHz for spurious emissions above 1 GHz.
  - 2) Video Bandwidth  $\geq 3$  times the resolution bandwidth.
  - 3) Sweep Speed  $\leq 2000$  Hz per second.
  - 4) Detector Mode = mean or average power.
- e) Adjust the center frequency of the spectrum analyzer for incremental coverage of the range from:
  - 1) The lowest radio frequency generated in the equipment to the carrier frequency minus the test bandwidth (see 1.3.4.4).

- 2) The carrier frequency plus the test bandwidth to a frequency less than 2 times the carrier frequency.
- f) Record the frequencies and levels of spurious emissions from step e).
- g) Insert the notch filter.
- h) Adjust the spectrum analyzer for the following settings:
  - 1) Resolution Bandwidth = 10 kHz for spurious emissions below 1 GHz, and 1 MHz for spurious emissions above 1 GHz.
  - 2) Video Bandwidth  $\geq 3$  times the resolution bandwidth.
  - 3) Sweep Speed  $\leq 2000$  Hz per second.
  - 4) Detector Mode = mean or average power.
- i) Key the transmitter. Adjust the center frequency of the spectrum analyzer for incremental coverage of the range from a frequency equal to 2 times the carrier frequency and to the tenth harmonic of the carrier frequency.

▣ **LIMIT**

Frequency Band (MHz)	Channel bandwidth (kHz)	Limit (dB)
450 – 512	12.5	50+10Log(P) or 70 dB

**Note**

- 1. Correct Level (dBm) : Substitute SG Level (dBm)
- 2. Emission Level (dBc) : Correct Level – 10Log(P\*1000)
- 3. P = Carrier Output Power(W)  
( P value, please refer to Section 7.1)

■ TEST RESULTS

7K60FXD, 7K60FXE

No.	Frequency (MHz)	Band	Setting	Spurious Frequency (MHz)	Correct Level (dBm)	Emission Level (dBc)	Limit (dBc)	Margin (dB)
1	450.05	Low	High Power	900.09	-55.598	-92.517	-56.919	35.598
				858.38	-56.439	-93.358	-56.919	36.439
				2690.2	-37.318	-74.237	-56.919	17.318
2	481.05	Middle		962.17	-55.945	-92.747	-56.802	35.945
				868.08	-56.419	-93.221	-56.802	36.419
				3154.3	-37.379	-74.181	-56.802	17.379
3	511.95	High		878.75	-56.376	-93.327	-56.951	36.376
				887.48	-56.391	-93.342	-56.951	36.391
				1024	-36.429	-73.380	-56.951	16.429
4	450.05	Low	Low Power	900.09	-58.867	-88.165	-49.298	38.867
				867.11	-60.730	-90.028	-49.298	40.73
				3156.80	-37.384	-66.682	-49.298	17.384
5	481.05	Middle		878.75	-56.439	-86.178	-49.739	36.439
				905.91	-56.459	-86.198	-49.739	36.459
				3154.30	-37.623	-67.362	-49.739	17.623
6	511.95	High		893.30	-56.454	-86.212	-49.758	36.454
				920.46	-56.483	-86.241	-49.758	36.483
				3175.80	-37.688	-67.446	-49.758	17.688

■ Plots of Unwanted Emissions : Conducted Spurious Emission FCC

450.05 MHz\_HIGH POWER

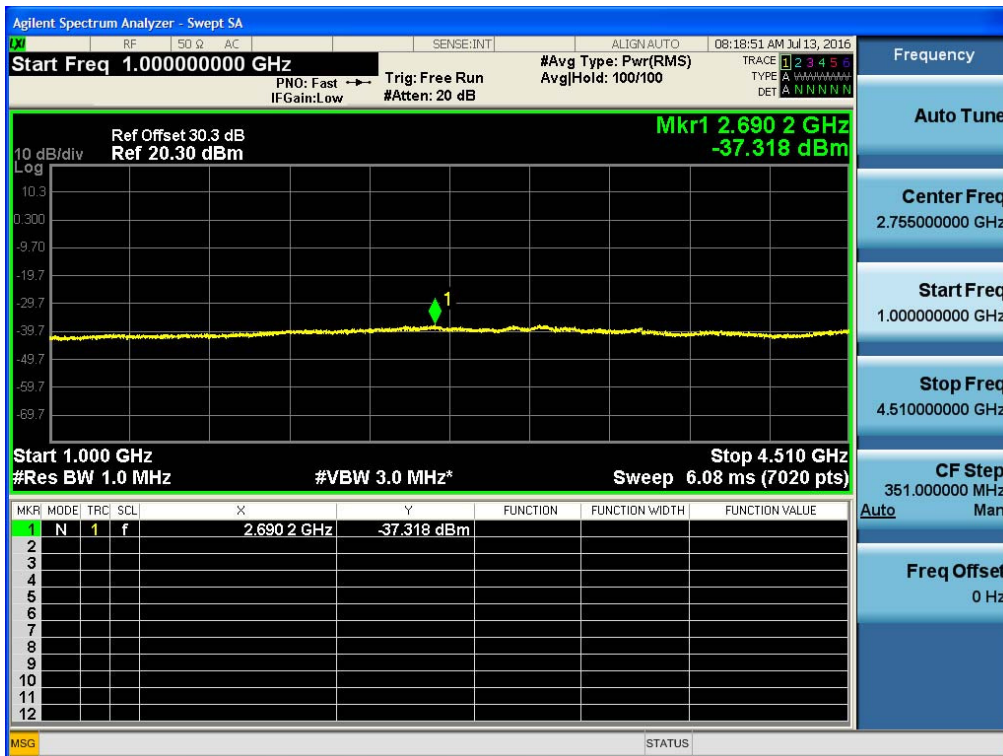
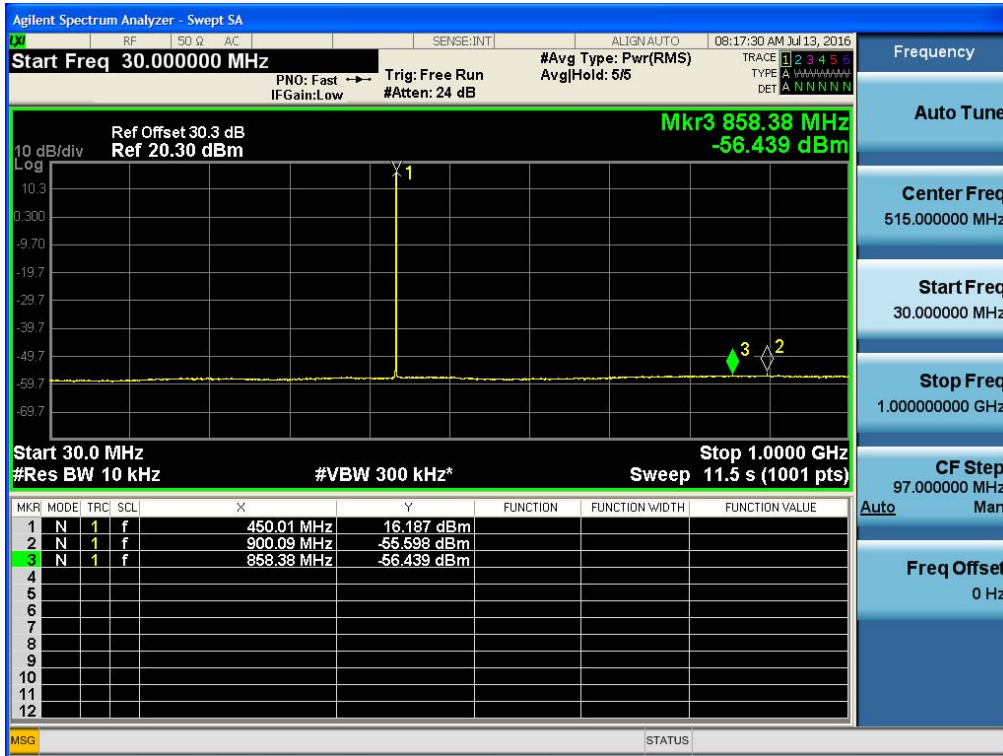



481.05 MHz\_HIGH POWER

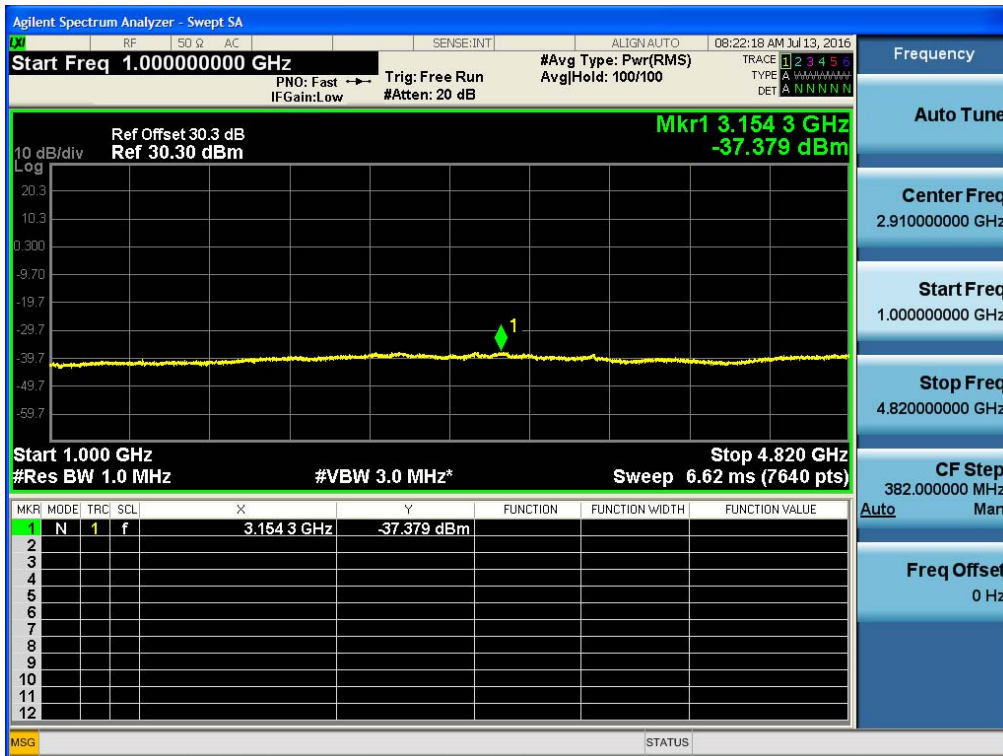
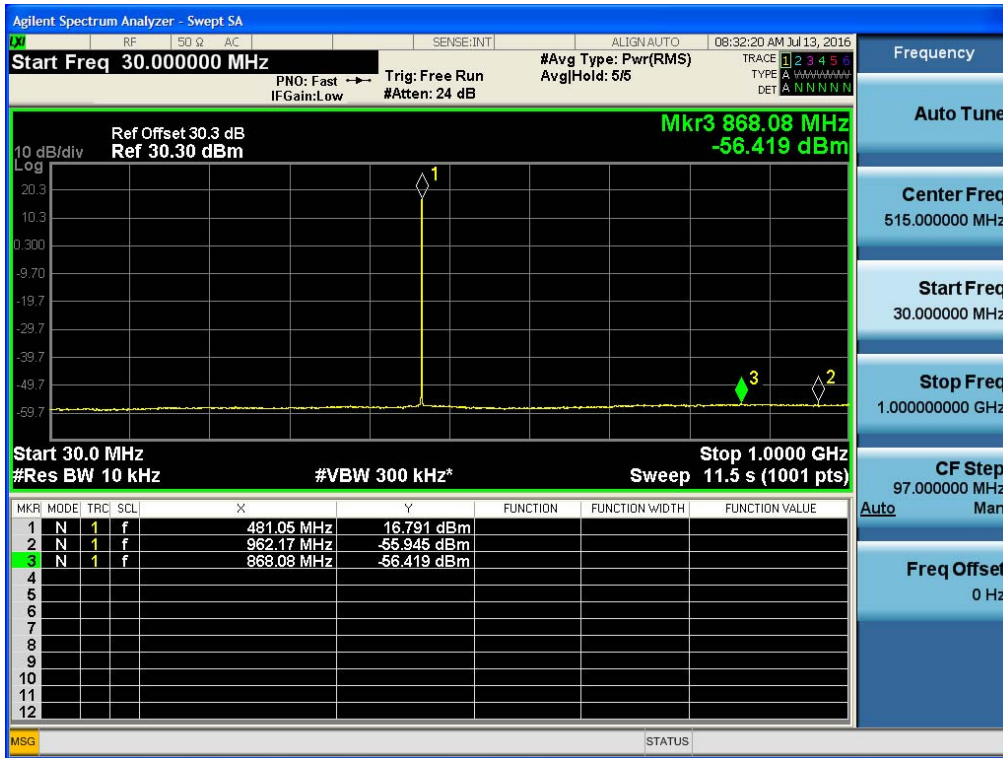

511.95 MHz\_HIGH POWER

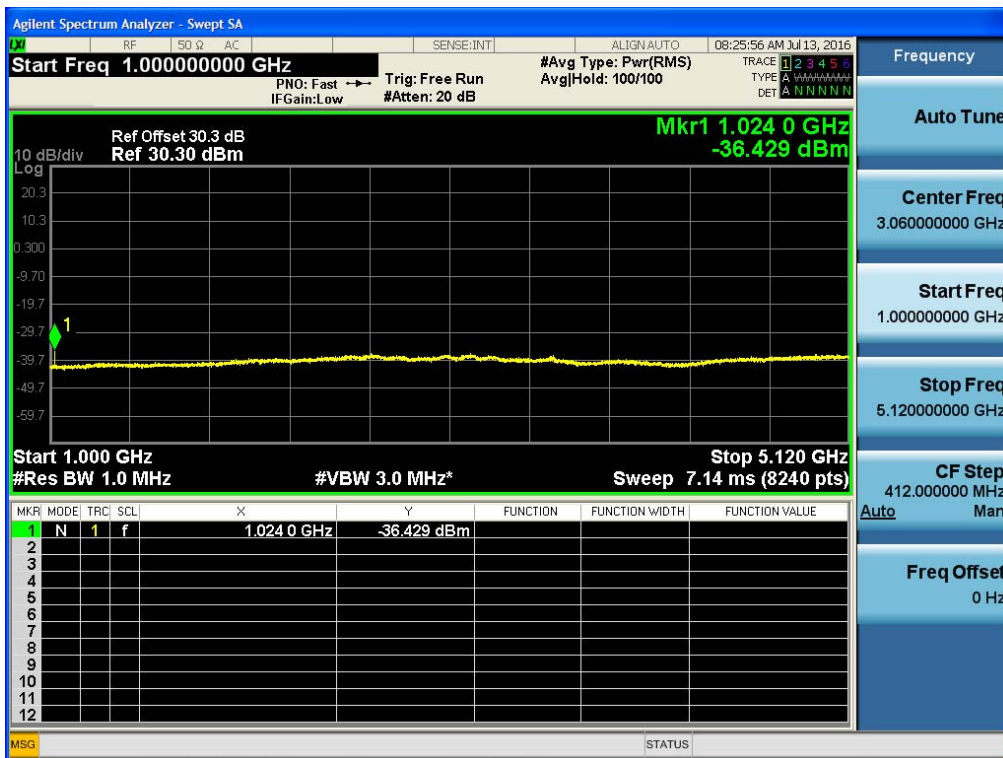
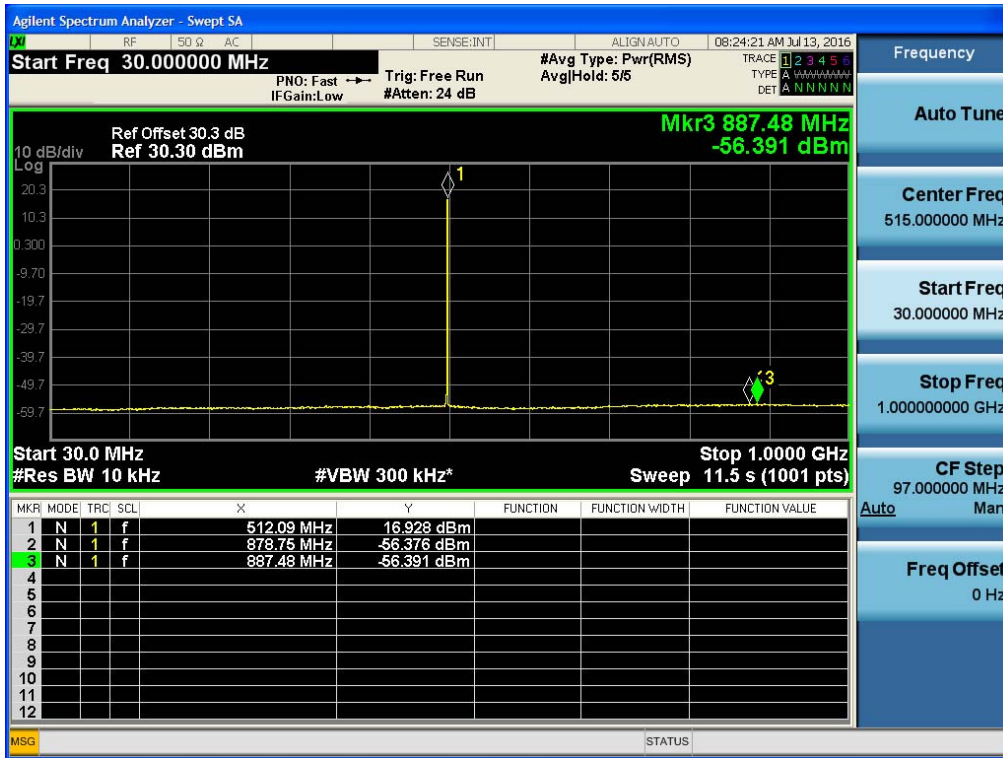



450.05 MHz\_LOW POWER

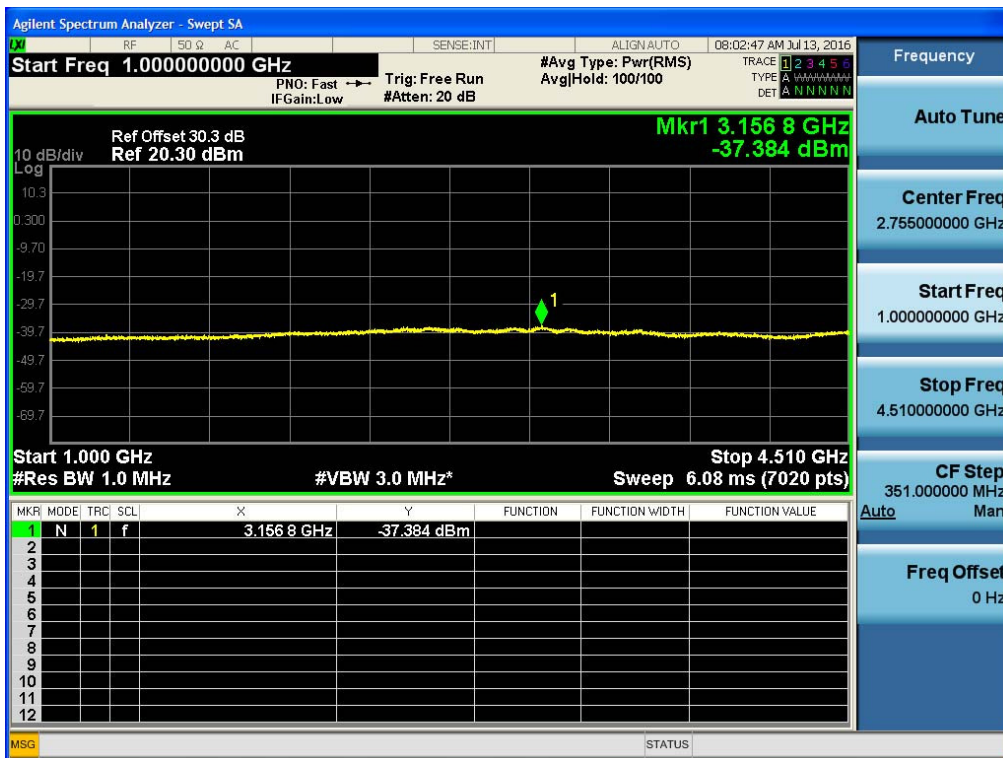
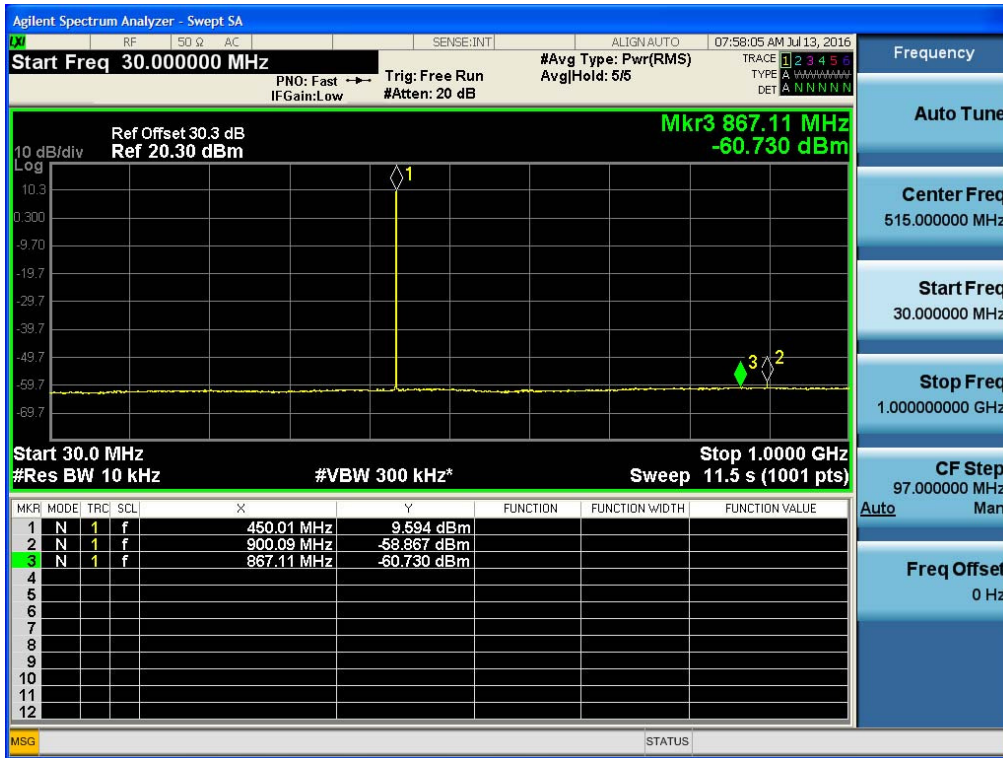

481.05 MHz\_LOW POWER

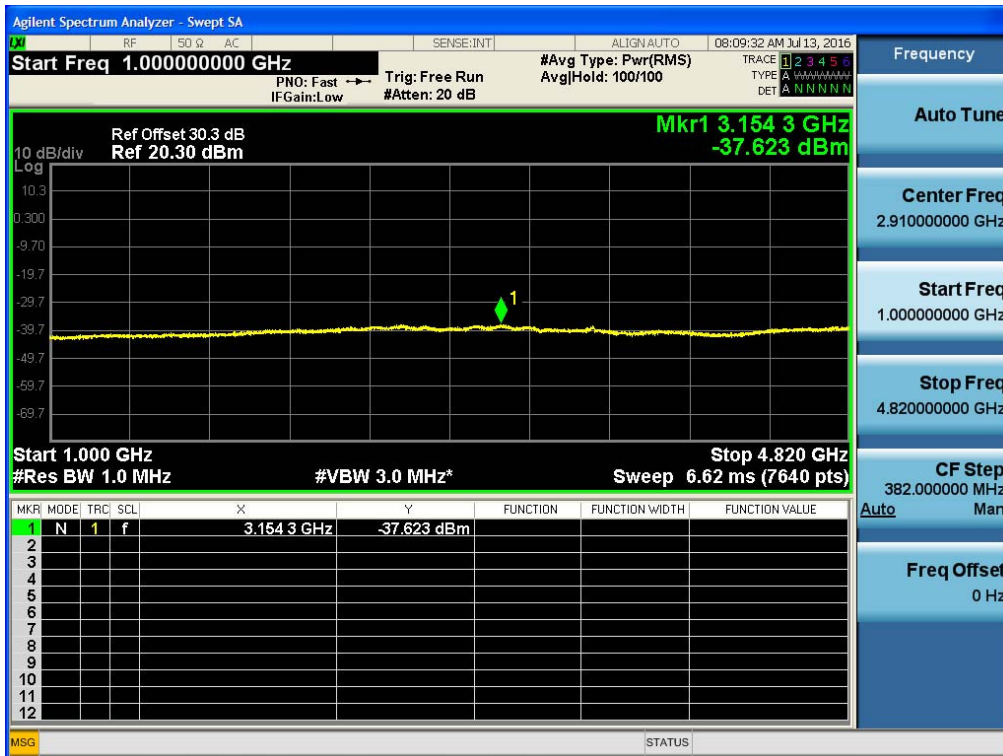
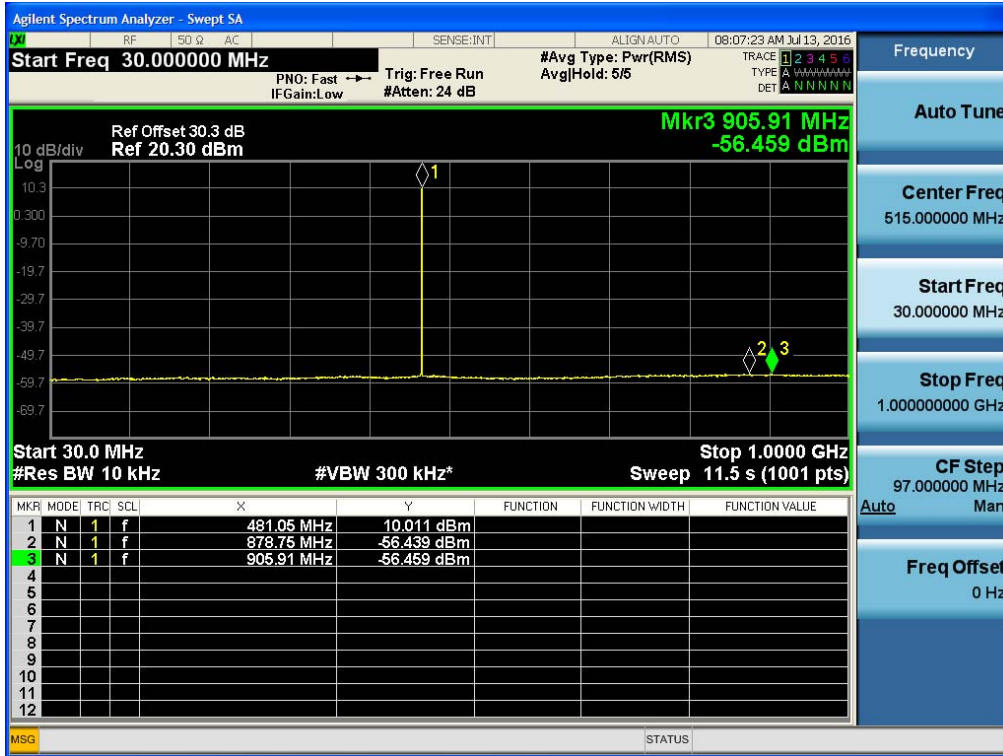

### 511.95 MHz\_LOW POWER

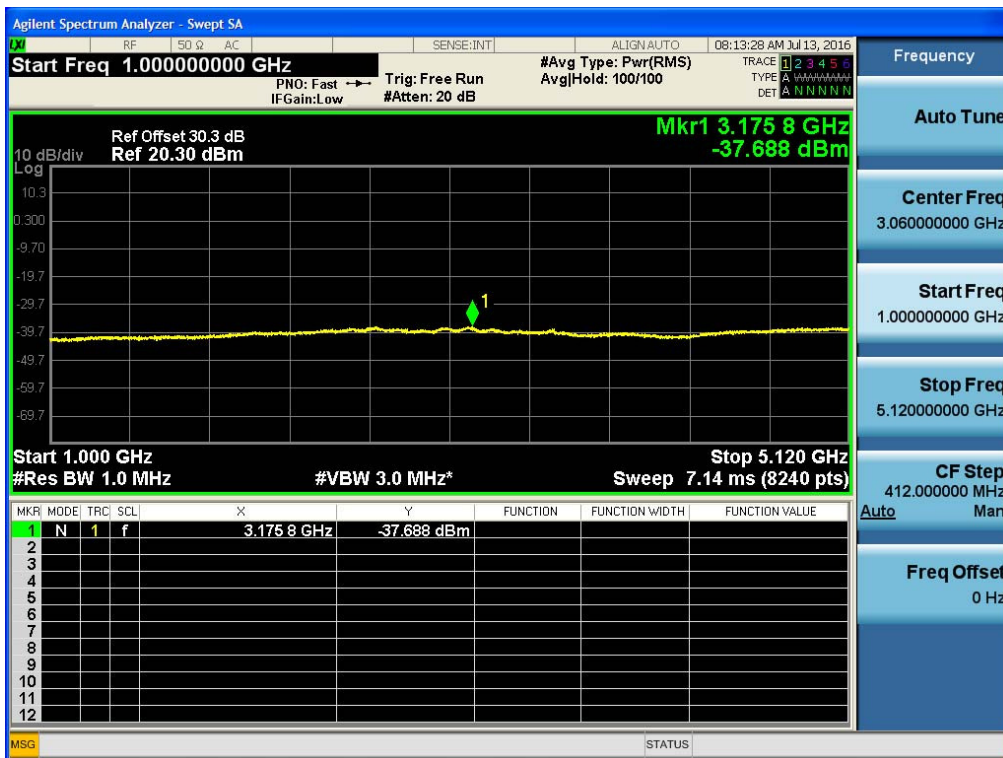
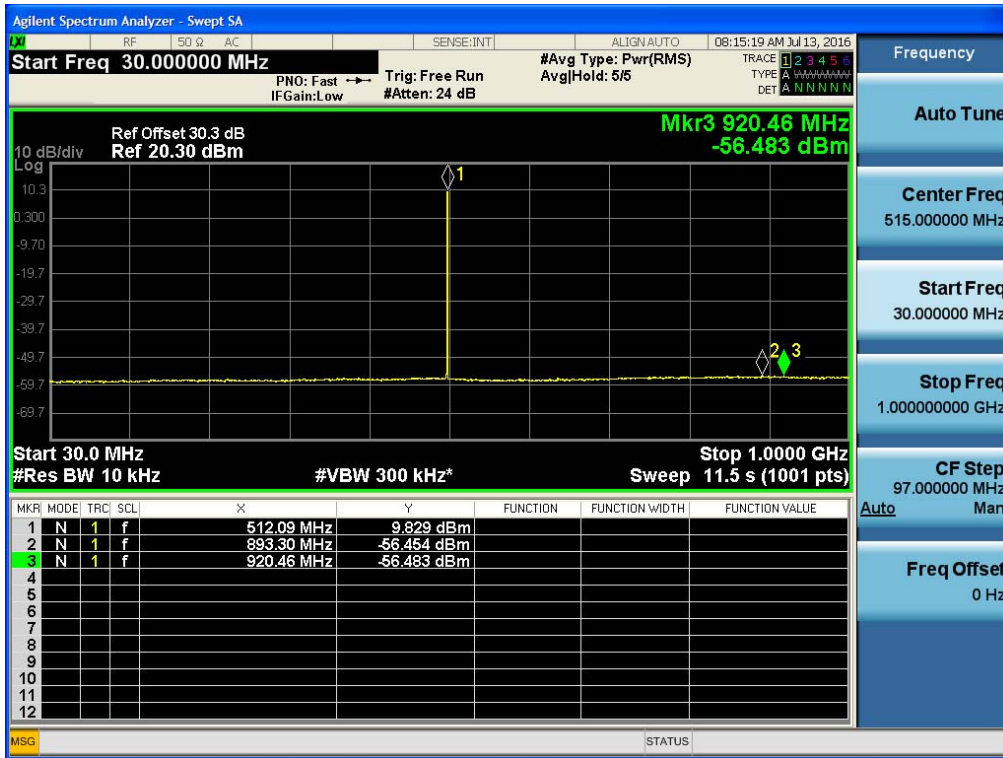

## 7.5 Unwanted Emissions : Radiated Spurious Emission

### ■ Definition

Radiated spurious emissions are emissions from the equipment when transmitting into a non-radiating load on a frequency or frequencies that are outside an occupied band sufficient to ensure transmission of information of required quality for the class of communications desired.

### ■ TEST CONFIGURATION

#### Below 1 GHz

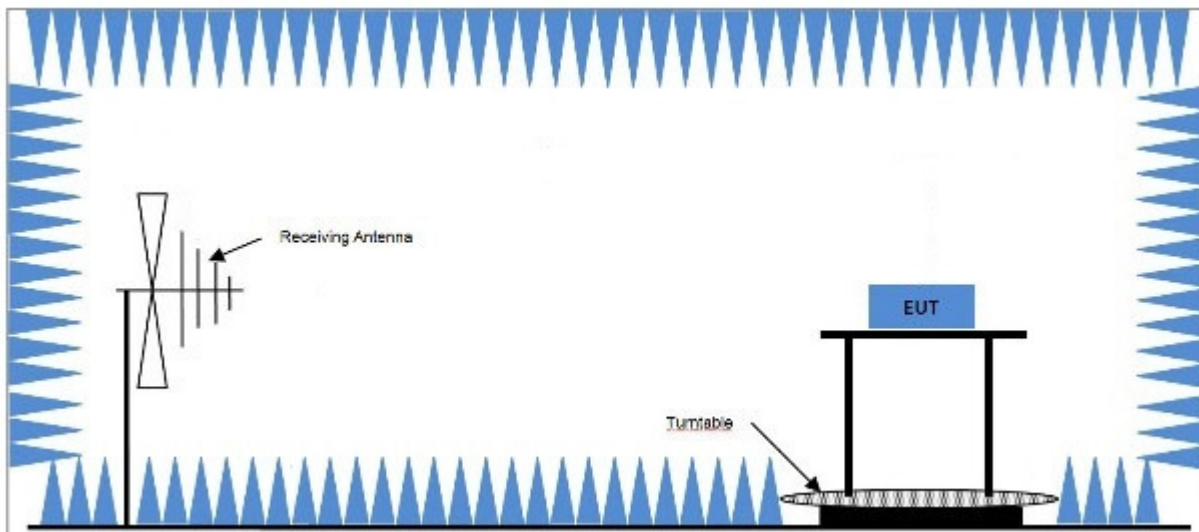

#### Above 1 GHz

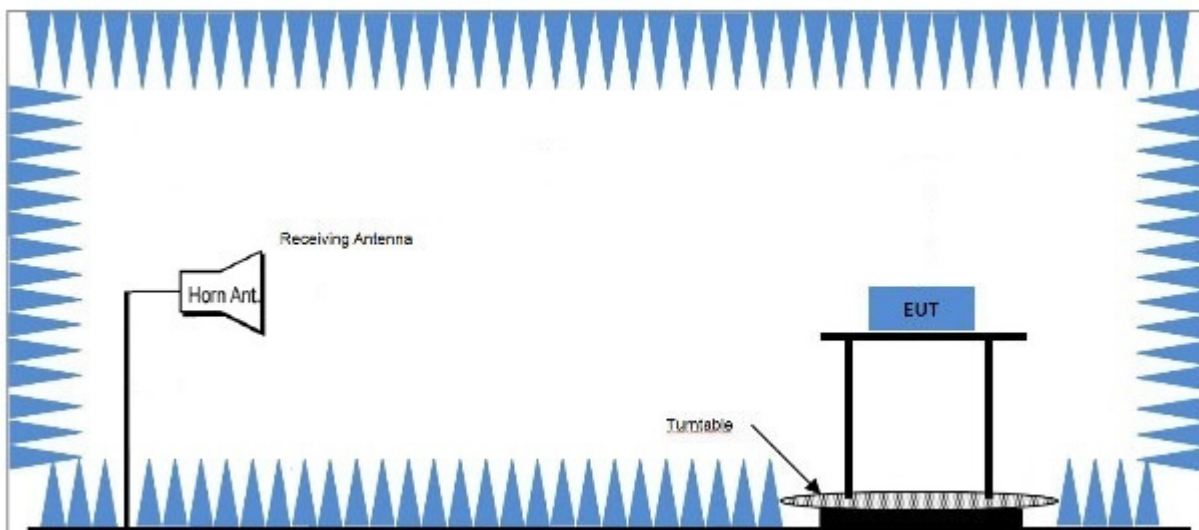

## TEST PROCEDURE USED

According to 2.2.12 in TIA-603-D Standard.

- a) Connect the equipment as illustrated.
- b) Adjust the spectrum analyzer for the following settings:
  - 1) Resolution Bandwidth = 10 kHz for spurious emissions below 1 GHz, and 1 MHz for spurious emissions above 1GHz.
  - 2) Video Bandwidth = 300 kHz for spurious emissions below 1 GHz, and 3 MHz for spurious emissions above 1 GHz.
  - 3) Sweep Speed slow enough to maintain measurement calibration.
  - 4) Detector Mode = Positive Peak.
- c) Place the transmitter to be tested on the turntable in the standard test site, or an FCC listed site compliant with ANSI C63.4-2001 clause 5.4. The transmitter is transmitting into a nonradiating load that is placed on the turntable. The RF cable to this load should be of minimum length. For transmitters with integral antennas, the tests are to be run with the unit operating into the integral antenna.
- d) For each spurious measurement the test antenna should be adjusted to the correct length for the frequency involved. This length may be determined from a calibration ruler supplied with the equipment. Measurements shall be made from the lowest radio frequency generated in the equipment to the tenth harmonic of the carrier, except for the region close to the carrier equal to  $\pm$  the test bandwidth (see 1.3.4.4).
- e) Key the transmitter.
- f) For each spurious frequency, raise and lower the test antenna from 1 m to 4 m to obtain a maximum reading on the spectrum analyzer with the test antenna at horizontal polarity. Then the turntable should be rotated 360° to determine the maximum reading.  
Repeat this procedure to obtain the highest possible reading. Record this maximum reading.
- g) Repeat step f) for each spurious frequency with the test antenna polarized vertically.
- h) Reconnect the equipment as illustrated.
- i) Keep the spectrum analyzer adjusted as in step b).
- j) Remove the transmitter and replace it with a substitution antenna (the antenna should be half-wavelength for each frequency involved). The center of the substitution antenna should be approximately at the same location as the center of the transmitter. At the lower frequencies, where the substitution antenna is very long, this will be impossible to achieve when the antenna is polarized vertically. In such case the lower end of the antenna should be 0.3 m above the ground.
- k) Feed the substitution antenna at the transmitter end with a signal generator connected to the antenna by means of a nonradiating cable. With the antennas at both ends horizontally polarized, and with the signal generator tuned to a particular spurious frequency, raise and



lower the test antenna to obtain a maximum reading at the spectrum analyzer. Adjust the level of the signal generator output until the previously recorded maximum reading for this set of conditions is obtained. This should be done carefully repeating the adjustment of the test antenna and generator output.

l) Repeat step k) with both antennas vertically polarized for each spurious frequency.

m) Calculate power in dBm into a reference ideal half-wave dipole antenna by reducing the readings obtained in steps k) and l) by the power loss in the cable between the generator and the antenna, and further corrected for the gain of the substitution antenna used relative to an ideal half-wave dipole antenna by the following formula:

$$Pd(\text{dBm}) = Pg(\text{dBm}) - \text{cable loss (dB)} + \text{antenna gain (dB)}$$

where:

$Pd$  is the dipole equivalent power and

$Pg$  is the generator output power into the substitution antenna.

n) The  $Pd$  levels record in step m) are the absolute levels of radiated spurious emissions in dBm.

The radiated spurious emissions in dB can be calculated by the following:

Radiated spurious emissions (dB) =

$$10 \cdot \log_{10}(\text{TX power in watts}/0.001) - \text{the levels in step m)}$$

■ **LIMIT**

Frequency Band (MHz)	Channel bandwidth (kHz)	Limit (dBm)
450 – 512	12.5	-20

■ **Operating Mode**

EUT Type (Worst case)	Modulation	Battery	Test frequency (MHz)
Stand alone	7K60FXD, 7K60FXE	EX-4621	450.05
		EX-4622	481.05
		EX-4623	511.95

■ TEST RESULTS

7K60FXD, 7K60FXE

Frequency : 450.05

Battery : EX-4621

Freq(MHz)	Reading[dBm]	Factor(dBm)	Pol	Result(dB)	Limit(dB)	Margin(dB)
450.05	-40.94	27.26	Z-H	-13.68	-	-
900.10	-76.79	33.10	Z-H	-43.69	-20	23.69

7K60FXD, 7K60FXE

Frequency : 481.05

Battery : EX-4621

Freq(MHz)	Reading[dBm]	Factor(dBm)	Pol	Result(dB)	Limit(dB)	Margin(dB)
481.05	-41.69	27.33	Z-H	-14.36	-	-
962.10	-80.42	33.66	Z-H	-46.76	-20	26.76

7K60FXD, 7K60FXE

Frequency : 511.95

Battery : EX-4621

Freq(MHz)	Reading[dBm]	Factor(dBm)	Pol	Result(dB)	Limit(dB)	Margin(dB)
511.95	-42.37	27.54	Z-H	-14.83	-	-
1023.9	-77.68	36.80	Z-H	-40.88	-20	20.88

**Note**

1. Result (dBm) = Reading + Factor
2. Limit (dBm) = -20

## 8. LIST OF TEST EQUIPMENT

### 8.1 LIST OF TEST EQUIPMENT(Conducted Test)

Manufacturer	Model / Equipment	Calibration Date	Calibration Interval	Serial No.
Agilent	N9020A / Signal Analyzer	06/24/2016	Annual	MY51110085
Agilent	N9030A / Signal Analyzer	11/24/2015	Annual	MY49431210
Agilent	N1911A / Power Meter	03/11/2016	Annual	MY45100523
Agilent	N1921A / Power Sensor	03/11/2016	Annual	MY52260025
Hewlett Packard	E3632A / DC Power Supply	03/09/2016	Annual	KR75303962
Agilent	8498A / Attenuator(30 dB)	02/16/2016	Annual	51162
Neng Yeol	NY-THR18750 / Temp & Humidity Chamber	11/04/2015	Annual	NY-200912201A



**8.2 LIST OF TEST EQUIPMENT(Radiated Test)**

Manufacture	Model/ Equipment	Serial Number	Calibration Interval	Calibration Due
CERNEX	CBLU1183540B-01/ POWER AMP	25540	Annual	05/13/2017
Wainwright	WHKX 10-900-1000-15000-40SS/H.P.F	5	Annual	08/11/2016
Schwarzbeck	BBHA 9120D/ Horn Antenna	9210D-1299	Biennial	10/16/2016
REOHDE&SCHWARZ	FSV40-N/Signal Analyzer	101068-SZ	Annual	09/23/2016
Schwarzbeck	VULB9160/ Bilog Antenna	3368	Biennial	10/10/2016
Agilent	8498A / Attenuator(30 dB)	51162	Annual	02/16/2017
narda	termination	-	-	-