

REPORT

FCC Certification

Applicant Name:
JVC KENWOOD Corporation**Address:**
1-16-2, Hakusan, Midori-ku, Yokohama-shi, Kanagawa,
226-8525 Japan**Date of Issue:**

October 30, 2014

Test Site/Location:

HCT CO., LTD., 74, Seoicheon-ro 578beon-gil, Majang-myeon, Icheon-si, Gyeonggi-do, Korea

Report No.: HCT-R-1410-F017**HCT FRN:** 0005866421**IC Recognition No.:** 5944A-3

FCC ID:	K44431400
IC:	282F-431400
APPLICANT:	JVC KENWOOD Corporation

FCC Model(s): NX-5200-K2, NX-5200-K3, NX-5200-F2, NX-5200-F3**IC Model(s):** NX-5200-K2, NX-5200-K3**EUT Type:** VHF P25 TRANSCEIVER with Bluetooth**Frequency Range:** FCC : 150 MHz - 174 MHz
IC : 138 MHz - 144 MHz and 148 MHz - 174 MHz**FCC Rule Part(s):** Part 90 and Part 2**IC Rule:** RSS- Gen Issue 3, RSS-119 Issue 11

The measurements shown in this report were made in accordance with the procedures specified in §2.947. I assume full responsibility for the accuracy and completeness of these measurements, and for the qualifications of all persons taking them.

HCT CO., LTD. Certifies that no party to this application has subject to a denial of Federal benefits that includes FCC benefits pursuant to section 5301 of the Anti-Drug Abuse Act of 1998, 21 U.S. C. 853(a)



Report prepared by
: Kwon Jeong
Test engineer of RF Team



Approved by
: Chang Seok Choi
Manager of RF Team

This report only responds to the tested sample and may not be reproduced, except in full, without written approval of the HCT Co., Ltd.

Version

TEST REPORT NO.	DATE	DESCRIPTION
HCT-R-1410-F017	October 30, 2014	- First Approval Report

Table of Contents

1. GENERAL INFORMATION	4
2. EUT DESCRIPTION	5
3. TEST METHODOLOGY	6
3.1 EUT CONFIGURATION	6
3.2 EUT EXERCISE	6
3.3 GENERAL TEST PROCEDURES	6
3.4 DESCRIPTION OF TEST MODES	6
3.5 Type of Emission.....	7
4. INSTRUMENT CALIBRATION.....	7
5. FACILITIES AND ACCREDITATIONS	7
5.1 FACILITIES	7
5.2 EQUIPMENT	7
6. SUMMARY TEST OF RESULTS	8
7. TEST RESULT	9
7.1 Carrier Output Power	9
7.2 Carrier Frequency Stability	12
7.3 Occupied Bandwidth.....	23
7.4 Modulation Limiting	66
7.5 Audio Frequency Response / Audio Low Pass Filter Response.....	85
7.6 Emission Mask.....	105
7.7 Transient Frequency Behavior.....	144
7.8 Unwanted Emissions : Conducted Spurious Emission	218
7.9 Unwanted Emissions : Radiated Spurious Emission	305
7.10 Unwanted Emissions : Receiver Radiated Spurious Emission	336
7.11 Necessary Bandwidth Calculations	337
8. LIST OF TEST EQUIPMENT	338

1. GENERAL INFORMATION

Applicant: JVC KENWOOD Corporation
Address: 1-16-2, Hakusan, Midori-ku, Yokohama-shi, Kanagawa, 226-8525 Japan
FCC ID: K44431400
IC: 282F-431400
EUT Type: VHF P25 TRANSCEIVER with Bluetooth
FCC Model name(s): NX-5200-K2, NX-5200-K3, NX-5200-F2, NX-5200-F3
IC Model name(s): NX-5200-K2, NX-5200-K3
Date(s) of Tests: October 06, 2014 ~ October 17, 2014
Place of Tests: HCT Co., Ltd.
74, Seoicheon-ro 578beon-gil, Majang-myeon, Icheon-si, Gyeonggi-do, Korea
(IC Recognition No. : 5944A-3)

2. EUT DESCRIPTION

EUT Type	VHF P25 TRANSCEIVER with Bluetooth	
FCC Model Name	NX-5200-K2, NX-5200-K3, NX-5200-F2, NX-5200-F3	
IC Model Name	NX-5200-K2, NX-5200-K3	
Power Supply	DC 7.5 V	
Output Power	6 W (Power output continuously variable to 1 W)	
Battery type	Li-ion Battery (KNB-L1, KNB-L2, KNB-L3)	
Antenna type	KRA-26(M)	VHF Heriral Antenna (146-162MHz)
	KRA-26(M2)	VHF Heriral Antenna (162-174 MHz)
	KRA-26(M3)	VHF Heriral Antenna (136-150 MHz)
	KRA-22(M)	VHF low-profile helical antenna (146-162MHz)
	KRA-22(M2)	VHF low-profile helical antenna (162-174 MHz)
	KRA-22(M3)	VHF low-profile helical antenna (136-150 MHz)
	KRA-41(M)	VHF stubby antenna (146-162MHz)
	KRA-41(M2)	VHF stubby antenna (162-174 MHz)
	KRA-41(M3)	VHF stubby antenna (136-150 MHz)
	KRA-25	High gain VHF helically loaded whip antenna (148-162 MHz)
KRA-28	Broad-band VHF helically loaded whip antenna (140-170 MHz)	
Channel Bandwidth	FCC : 12.5 kHz / 6.25 kHz IC : 25 kHz/ 12.5 kHz / 6.25 kHz (25 kHz is IC only)	
Operating Temperature	-30 ~ +60	
Frequency Range	FCC : 150 MHz - 174 MHz IC : 138 MHz – 144 MHz and 148 MHz – 174 MHz	
Test Frequency	138.05 MHz (IC) 143.95 MHz (IC) 148.05 MHz (IC) 150.05 MHz (FCC) 162.05 MHz (FCC / IC) 173.95 MHz (FCC / IC)	

3. TEST METHODOLOGY

TIA-603-D dated June 24, 2010 entitled "Land Mobile FM or PM Communications Equipment Measurement and Performance Standards" were used in the measurement.

3.1 EUT CONFIGURATION

The EUT configuration for testing is installed on RF field strength measurement to meet the Commissions requirement and operating in a manner that intends to maximize its emission characteristics in a continuous normal application.

3.2 EUT EXERCISE

The EUT was operated in the engineering mode to fix the Tx frequency that was for the purpose of the measurements. According to its specifications, the EUT must comply with the requirements of the FCC Rules Part 2 and Part 90.

3.3 GENERAL TEST PROCEDURES

Radiated Emissions

Radiated emission measurements are performed in the Fully-anechoic chamber. The equipment under test is placed on a non-conductive table 3-meters away from the receive antenna in accordance with ANSI/TIA-603-D-2010 Clause 2.2.17. The turntable is rotated through 360 degrees, and the receiving antenna scans in order to determine the level of the maximized emission. The level and position of the maximized emission is recorded with the spectrum analyzer using a positive peak detector.

A half wave dipole is then substituted in place of the EUT. For emissions above 1GHz, a horn antenna is substituted in place of the EUT. The substitute antenna is driven by a signal generator and the previously recorded signal was duplicated.

The power is calculated by the following formula;

$$P_{d(\text{dBm})} = P_{g(\text{dBm})} - \text{cable loss}_{(\text{dB})} + \text{antenna gain}_{(\text{dB})}$$

Where: P_d is the dipole equivalent power and P_g is the generator output power into the substitution antenna.

The maximum EIRP is calculated by adding the forward power to the calibrated source plus its appropriate gain value. These steps are repeated with the receiving antenna in both vertical and horizontal polarization. the difference between the gain of the horn and an isotropic antenna are taken into consideration

3.4 DESCRIPTION OF TEST MODES

The EUT has been tested under operating condition. Test program used to control the EUT for staying in continuous transmitting is programmed.

3.5 Type of Emission

16K0F3E	(Analogue)
11K0F3E	(Analogue)
8K10F1E, 8K10F1D	(P25 phase1)
8K10F1W	(P25 phase 2, TDMA)
8K30F1E, 8K30F1D, 8K30F7W	(NXDN)
4K00F1E, 4K00F1D, 4K00F7W	(NXDN)
4K00F2D	(CWID) : Use only low power

4. INSTRUMENT CALIBRATION

The measuring equipment, which was utilized in performing the tests documented herein, has been calibrated in accordance with the manufacturer's recommendations for utilizing calibration equipments, which is traceable to recognized national standards.

5. FACILITIES AND ACCREDITATIONS

5.1 FACILITIES

The Fully-anechoic chamber and conducted measurement facility used to collect the radiated data are located at the 74, Seoicheon-ro 578beon-gil, Majang-myeon, Icheon-si, Gyeonggi-do, Korea.

5.2 EQUIPMENT

Radiated emissions are measured with one or more of the following types of Linearly polarized antennas: tuned dipole, bi-conical, log periodic, bi-log, and/or ridged waveguide, horn. Spectrum analyzers with pre-selectors and quasi-peak detectors are used to perform radiated measurements.

Conducted emissions are measured with Line Impedance Stabilization Networks and EMI Test Receivers. Calibrated wideband preamplifiers, coaxial cables, and coaxial attenuators are also used for making measurements.

All receiving equipment conforms to CISPR Publication 16-1, "Radio Interference Measuring Apparatus and Measurement Methods."

6. SUMMARY TEST OF RESULTS

Test Description	FCC Part Section(s)	IC Part Section(s)	Test Limit	Test Condition	Test Result
Carrier RF Output Power	§90.205(i) §2.1046(a)	RSS119-i11(5.4)	Varies	CONDUCTED	PASS
Unwanted Emissions	§2.1051	RSS119-i11(5.8)			PASS
99% Bandwidth(IC)	NA	NA	NA		PASS
Carrier Frequency Stability	§90.213(a), §2.1055	RSS119-i11(5.3)	Channel Spacing : 6.25 kHz = 2 ppm Channel Spacing : 12.5 kHz = 5 ppm 25 kHz = 5 ppm		PASS
Audio Frequency Response	§2.1047(a)	RSS119-i11(5.8.1)	Varies		PASS
Audio Low Pass Filter	§2.1047(a)	RSS119-i11(5.8.1)			PASS
Modulation Limiting	§2.1047(b)	RSS119-i11(5.8.1)			PASS
Transient Frequency Behavior	§90.214	RSS119-i11(5.2)	Varies		PASS
Emission Mask	§90.210, §2.1049(c)(1)	RSS119-i11(5.5)	Varies		PASS
Field Strength of Spurious Radiation	§2.1053	RSS119-i11(5.8)	Varies		RADIATED
Receiver Spurious Emissions	§15.109(a)	RSS119-i11(5.11) RSS-Gen	cf. Section 7.10	PASS	
Necessary Bandwidth	§2.202(g)		-	-	-

7. TEST RESULT

7.1 Carrier Output Power

Definition

The conducted carrier power output rating for a transmitter is the power available at the output terminals of the transmitter when the output terminals are connected to the standard transmitter load.

TEST CONFIGURATION

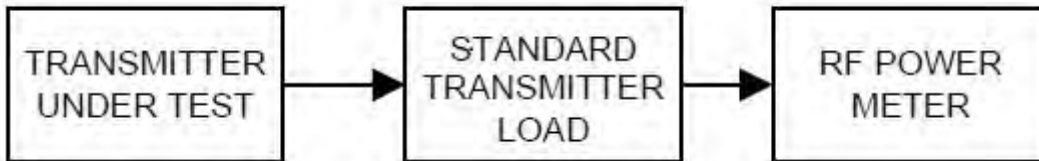

TEST PROCEDURE

According to 2.2.1 in TIA-603-D Standard.

- a) Connect the equipment as illustrated.
- b) Measure the transmitter output power during the defined duty cycle(see 1.3.2).
Correct for all losses in the RF path.
- c) The value recorded in step b) is the conducted carrier output power rating.

TEST RESULTS

For FCC

Mode	Type of Emission	Channel Spacing	Freq.(MHz)	Carrier Output Power			
				Low		High	
				dBm	W	dBm	W
Analog	11K0F3E	12.5 kHz	150.05	30.04	1.010	37.64	5.813
			162.05	29.74	0.941	37.45	5.563
			173.95	30.05	1.012	37.47	5.578
Digital	8K10F1E, 8K10F1D	12.5 kHz	150.05	30.01	1.003	37.70	5.890
			162.05	29.66	0.925	37.47	5.583
			173.95	30.01	1.002	37.49	5.604
	8K10F1W	12.5 kHz	150.05	30.18	1.043	37.62	5.781
			162.05	29.88	0.973	37.46	5.572
			173.95	30.15	1.036	37.42	5.517
	8K30F1E, 8K30F1D, 8K30F7W	12.5 kHz	150.05	30.13	1.030	37.67	5.841
			162.05	29.83	0.961	37.49	5.610
			173.95	30.10	1.023	37.50	5.627
	4K00F1E, 4K00F1D, 4K00F7W	6.25 kHz	150.05	30.05	1.011	37.68	5.860
			162.05	29.75	0.944	37.51	5.630
			173.95	30.06	1.014	37.45	5.562
	4K00F2D	6.25 kHz	150.05	29.90	0.977	N/A	
			162.05	29.68	0.929		
			173.95	29.99	0.998		

For IC

Mode	Type of Emission	Channel Spacing	Freq.(MHz)	Carrier Output Power			
				Low		High	
				dBm	W	dBm	W
Analog	16K0F3E	25 kHz	138.05	30.30	1.071	37.54	5.677
			143.95	30.02	1.005	37.53	5.658
			148.05	30.04	1.009	37.56	5.704
	11K0F3E	12.5 kHz	138.05	30.18	1.042	37.55	5.687
			143.95	29.97	0.993	37.52	5.649
			148.05	30.02	1.004	37.57	5.717
Digital	8K10F1E, 8K10F1D	12.5 kHz	138.05	30.28	1.067	37.62	5.777
			143.95	30.00	1.001	37.53	5.664
			148.05	30.05	1.012	37.58	5.725
	8K10F1W	12.5 kHz	138.05	30.16	1.037	37.69	5.878
			143.95	29.91	0.980	37.60	5.757
			148.05	29.99	0.997	37.62	5.780
	8K30F1E, 8K30F1D, 8K30F7W	12.5 kHz	138.05	30.28	1.067	37.66	5.837
			143.95	30.02	1.004	37.58	5.732
			148.05	30.04	1.009	37.62	5.778
	4K00F1E, 4K00F1D, 4K00F7W	6.25 kHz	138.05	30.19	1.046	37.61	5.761
			143.95	29.94	0.987	37.55	5.683
			148.05	29.99	0.997	37.57	5.716
	4K00F2D	6.25 kHz	138.05	30.01	1.002	N/A	
			143.95	29.85	0.965		
			148.05	29.94	0.987		

7.2 Carrier Frequency Stability

Definition

The carrier frequency stability is the ability of the transmitter to maintain an assigned carrier frequency.

TEST CONFIGURATION



TEST PROCEDURE

According to 2.2.2 in TIA-603-D Standard.

- a) Connect the equipment as illustrated.
- b) Operate the equipment in standby conditions for 15 minutes before proceeding.
- c) Record the carrier frequency of the transmitter as MCF_{MHz}
- d) Calculate the ppm frequency error by the following:

$$\text{ppm error} = ((MCF_{\text{MHz}} / ACF_{\text{MHz}}) - 1) * 10^6$$

where

MCF_{MHz} is the Measured Carrier Frequency in MHz

ACF_{MHz} is the Assigned Carrier Frequency in MHz

- e) The value recorded in step d) is the carrier frequency stability.

Note

In order to simplify the report, attached data were only the worst case frequency stability.

(Type of Emission (worst case) : 4K00F1E, 4K00F1D, 4K00F7W)

TEST RESULTS - 4K00F1E, 4K00F1D, 4K00F7W For FCC**(1) Frequency Stability (Temperature Variation)**

150.05 MHz (High Power)

Temperature (Degree C)	Frequency (MHz)	Frequency stability (ppm)
-30	150.050002	0.015
-20	150.050006	0.043
-10	150.050005	0.031
0	150.050005	0.035
10	150.050013	0.084
20	150.049989	-0.073
30	150.049994	-0.041
40	150.050002	0.011
50	150.050003	0.022
60	150.050006	0.043

162.05 MHz (High Power)

Temperature (Degree C)	Frequency (MHz)	Frequency stability (ppm)
-30	162.050003	0.019
-20	162.050008	0.047
-10	162.050005	0.030
0	162.050005	0.033
10	162.050013	0.081
20	162.049988	-0.075
30	162.049993	-0.043
40	162.050002	0.010
50	162.050003	0.020
60	162.050008	0.047

173.95 MHz (High Power)

Temperature (Degree C)	Frequency (MHz)	Frequency stability (ppm)
-30	173.950006	0.033
-20	173.950009	0.050
-10	173.950006	0.034
0	173.950007	0.039
10	173.950014	0.081
20	173.949992	-0.045
30	173.949993	-0.041
40	173.950002	0.009
50	173.950004	0.021
60	173.950009	0.050

150.05 MHz (Low Power)

Temperature (Degree C)	Frequency (MHz)	Frequency stability (ppm)
-30	150.050008	0.054
-20	150.050008	0.054
-10	150.050007	0.046
0	150.050005	0.036
10	150.050012	0.080
20	150.049997	-0.022
30	150.049995	-0.036
40	150.050002	0.013
50	150.050005	0.031
60	150.050008	0.054

162.05 MHz (Low Power)

Temperature (Degree C)	Frequency (MHz)	Frequency stability (ppm)
-30	162.050009	0.053
-20	162.050009	0.053
-10	162.050008	0.047
0	162.050006	0.036
10	162.050013	0.077
20	162.049997	-0.017
30	162.049994	-0.035
40	162.050002	0.011
50	162.050005	0.029
60	162.050009	0.053

173.95 MHz (Low Power)

Temperature (Degree C)	Frequency (MHz)	Frequency stability (ppm)
-30	173.950009	0.053
-20	173.950010	0.055
-10	173.950009	0.051
0	173.950007	0.038
10	173.950013	0.077
20	173.949998	-0.012
30	173.949994	-0.035
40	173.950002	0.009
50	173.950005	0.029
60	173.950010	0.055

(2) Frequency Stability (Voltage Variation)

150.05 MHz (High Power)

Temperature (Degree C)	Diviation (%)	Voltage (V)	Frequency (MHz)	Frequency stability (ppm)
25	85	6.375	150.049988	-0.077
25	100	7.500	150.049989	-0.075
25	115	8.625	150.049988	-0.078

162.05 MHz (High Power)

Temperature (Degree C)	Diviation (%)	Voltage (V)	Frequency (MHz)	Frequency stability (ppm)
25	85	6.375	162.049988	-0.076
25	100	7.500	162.049988	-0.076
25	115	8.625	162.049988	-0.075

173.95 MHz (High Power)

Temperature (Degree C)	Diviation (%)	Voltage (V)	Frequency (MHz)	Frequency stability (ppm)
25	85	6.375	173.949993	-0.043
25	100	7.500	173.949992	-0.044
25	115	8.625	173.949993	-0.041

150.05 MHz (Low Power)

Temperature (Degree C)	Diviation (%)	Voltage (V)	Frequency (MHz)	Frequency stability (ppm)
25	85	6.375	150.049997	-0.022
25	100	7.500	150.049997	-0.022
25	115	8.625	150.049997	-0.021

162.05 MHz (Low Power)

Temperature (Degree C)	Diviation (%)	Voltage (V)	Frequency (MHz)	Frequency stability (ppm)
25	85	6.375	162.049997	-0.017
25	100	7.500	162.049997	-0.017
25	115	8.625	162.049997	-0.016

173.95 MHz (Low Power)

Temperature (Degree C)	Diviation (%)	Voltage (V)	Frequency (MHz)	Frequency stability (ppm)
25	85	6.375	173.949998	-0.013
25	100	7.500	173.949998	-0.013
25	115	8.625	173.949998	-0.012

TEST RESULTS - 4K00F1E, 4K00F1D, 4K00F7W For IC**(1) Frequency Stability (Temperature Variation)**

138.05 MHz (High Power)

Temperature (Degree C)	Frequency (MHz)	Frequency stability (ppm)
-30	138.050008	0.055
-20	138.050007	0.053
-10	138.050005	0.037
0	138.050006	0.043
10	138.050011	0.081
20	138.049993	-0.047
30	138.049994	-0.040
40	138.050001	0.010
50	138.050003	0.022
60	138.050007	0.053

143.95 MHz (High Power)

Temperature (Degree C)	Frequency (MHz)	Frequency stability (ppm)
-30	143.950008	0.053
-20	143.950008	0.054
-10	143.950006	0.039
0	143.950005	0.033
10	143.950012	0.080
20	143.949998	-0.015
30	143.949994	-0.039
40	143.950001	0.010
50	143.950003	0.024
60	143.950008	0.054

148.05 MHz (High Power)

Temperature (Degree C)	Frequency (MHz)	Frequency stability (ppm)
-30	148.050008	0.053
-20	148.050008	0.054
-10	148.050006	0.042
0	148.050004	0.029
10	148.050012	0.079
20	148.049999	-0.008
30	148.049994	-0.038
40	148.050002	0.010
50	148.050004	0.025
60	148.050008	0.054

138.05 MHz (Low Power)

Temperature (Degree C)	Frequency (MHz)	Frequency stability (ppm)
-30	138.050007	0.053
-20	138.050007	0.054
-10	138.050007	0.052
0	138.050006	0.041
10	138.050011	0.076
20	138.050000	-0.003
30	138.049995	-0.035
40	138.050001	0.008
50	138.050004	0.031
60	138.050007	0.054

143.95 MHz (Low Power)

Temperature (Degree C)	Frequency (MHz)	Frequency stability (ppm)
-30	143.950008	0.053
-20	143.950008	0.053
-10	143.950008	0.052
0	143.950006	0.043
10	143.950011	0.074
20	143.949999	-0.008
30	143.949995	-0.034
40	143.950001	0.006
50	143.950004	0.031
60	143.950008	0.053

148.05 MHz (Low Power)

Temperature (Degree C)	Frequency (MHz)	Frequency stability (ppm)
-30	148.050008	0.053
-20	148.050008	0.053
-10	148.050008	0.055
0	148.050007	0.045
10	148.050011	0.074
20	148.049999	-0.009
30	148.049995	-0.033
40	148.050001	0.009
50	148.050005	0.032
60	148.050008	0.053

(2) Frequency Stability (Voltage Variation)

138.05 MHz (High Power)

Temperature (Degree C)	Diviation (%)	Voltage (V)	Frequency (MHz)	Frequency stability (ppm)
25	85	6.375	138.049994	-0.044
25	100	7.500	138.049994	-0.046
25	115	8.625	138.049994	-0.042

143.95MHz (High Power)

Temperature (Degree C)	Diviation (%)	Voltage (V)	Frequency (MHz)	Frequency stability (ppm)
25	85	6.375	143.949998	-0.016
25	100	7.500	143.949998	-0.015
25	115	8.625	143.949998	-0.014

148.05 MHz (High Power)

Temperature (Degree C)	Diviation (%)	Voltage (V)	Frequency (MHz)	Frequency stability (ppm)
25	85	6.375	148.049999	-0.009
25	100	7.500	148.049999	-0.008
25	115	8.625	148.049999	-0.008

138.05 MHz (Low Power)

Temperature (Degree C)	Diviation (%)	Voltage (V)	Frequency (MHz)	Frequency stability (ppm)
25	85	6.375	138.049999	-0.007
25	100	7.500	138.049999	-0.006
25	115	8.625	138.049999	-0.007

143.95 MHz (Low Power)

Temperature (Degree C)	Diviation (%)	Voltage (V)	Frequency (MHz)	Frequency stability (ppm)
25	85	6.375	143.949999	-0.009
25	100	7.500	143.949999	-0.008
25	115	8.625	143.949999	-0.009

148.05 MHz (Low Power)

Temperature (Degree C)	Diviation (%)	Voltage (V)	Frequency (MHz)	Frequency stability (ppm)
25	85	6.375	148.049998	-0.010
25	100	7.500	148.049999	-0.010
25	115	8.625	148.049998	-0.010

7.3 Occupied Bandwidth

Definition

The transmitter sideband spectrum denotes the sideband power produced at a discrete frequency separation from the carrier up to the test bandwidth (see TIA-603-D Section 1.3.4.4) due to all sources of unwanted noise within the transmitter in a modulated condition.

TEST CONFIGURATION

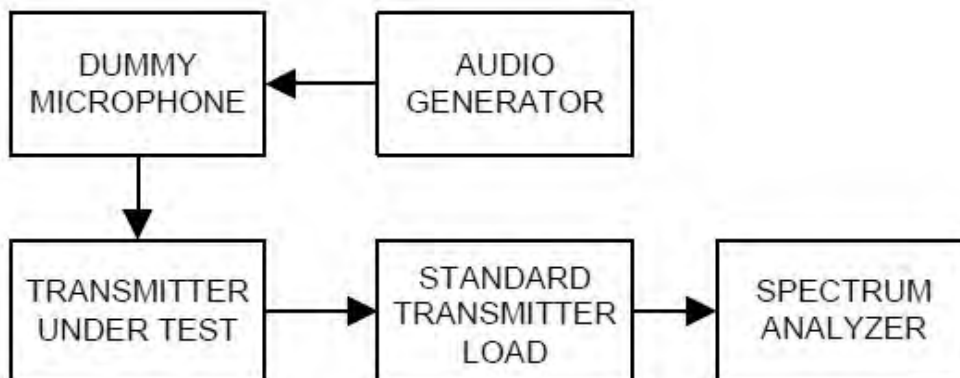

TEST PROCEDURE

According to TIA-603-D Section 2.2.11.2 / RSS-119 Section 5.5

- a) For EUT supporting audio modulation, the audio signal generator was adjusted to the frequency of maximum response and with output level set for +/- 2.5 kHz deviation (or 50 % modulation). (FM modulation).
- b) With level constant, the signal level was increased 16 dB..
- c) For EUT supporting digital modulation, the digital modulation mode was operated to its maximum extent.
- d) Adjust the spectrum analyzer for the following setting:
 - 1) RBW : 100Hz (Authorized Band 6 kHz),
100Hz (Authorized Band 11.25 kHz),
300Hz (Authorized Band 20 kHz)
 - 2) VBW : Video Bandwidth at least 10 times the resolution bandwidth.
 - 4) Sweep Speed : Sweep Speed slow enough to maintain measurement calibration.
 - 5) Sampling Time : 10 times
 - 6) Detector Mode = Positive Peak.
- e) The occupied Bandwidth was measured with the Spectrum Analyzer controls set as shown on the test results.

LIMIT

Frequency Band (MHz)	Channel bandwidth (kHz)	Authorized Bandwidth (kHz)
138 - 174	12.5	11.25
	6.25	6
	25	20

TEST RESULTS

Conducted 99% Bandwidth Measurements for 16K0F3E

16K0F3E Mode		Measured Bandwidth [kHz]	Setting
Frequency [MHz]	Channel bandwidth		
138.05	25 kHz	14.715	High Power
143.95		14.716	
148.05		14.718	
138.05	25 kHz	14.714	Low Power
143.95		14.715	
148.05		14.717	

Conducted 99% Bandwidth Measurements for 11K0F3E

11K0F3E Mode		Measured Bandwidth [kHz]	Setting
Frequency [MHz]	Channel bandwidth		
138.05	12.5 kHz	9.903	High Power
143.95		9.904	
148.05		9.904	
150.05		9.911	
162.05		9.911	
173.95		9.898	
138.05	12.5 kHz	9.904	Low Power
143.95		9.904	
148.05		9.905	
150.05		9.911	
162.05		9.911	
173.95		9.899	

Conducted 99% Bandwidth Measurements for 8K10F1E,8K10F1D

8K10F1E 8K10F1D Mode		Measured Bandwidth [kHz]	Setting
Frequency [MHz]	Channel bandwidth		
138.05	12.5 kHz	8.001	High Power
143.95		8.003	
148.05		8.000	
150.05		8.013	
162.05		8.006	
173.95		7.978	
138.05	12.5 kHz	8.006	Low Power
143.95		8.008	
148.05		8.003	
150.05		8.017	
162.05		8.017	
173.95		7.964	

Conducted 99% Bandwidth Measurements for 8K10F1W

8K10F1W Mode		Measured Bandwidth [kHz]	Setting
Frequency [MHz]	Channel bandwidth		
138.05	12.5 kHz	8.087	High Power
143.95		8.091	
148.05		8.097	
150.05		8.095	
162.05		8.096	
173.95		8.043	
138.05	12.5 kHz	8.096	Low Power
143.95		8.088	
148.05		8.099	
150.05		8.099	
162.05		8.094	
173.95		8.039	

Conducted 99% Bandwidth Measurements for 8K30F1E,8K30F1D,8K30F7W

8K30F1E 8K30F1D 8K30F7W Mode		Measured Bandwidth [kHz]	Setting
Frequency [MHz]	Channel bandwidth		
138.05	12.5 kHz	7.698	High Power
143.95		7.696	
148.05		7.697	
150.05		7.708	
162.05		7.698	
173.95		7.657	
138.05	12.5 kHz	7.708	Low Power
143.95		7.699	
148.05		7.696	
150.05		7.699	
162.05		7.691	
173.95		7.660	

Conducted 99% Bandwidth Measurements for 4K00F1E,4K00F1D,4K00F7W

4K00F1E 4K00F1D 4K00F7W Mode		Measured Bandwidth [kHz]	Setting
Frequency [MHz]	Channel bandwidth		
138.05	6.25 kHz	3.553	High Power
143.95		3.555	
148.05		3.561	
150.05		3.563	
162.05		3.551	
173.95		3.518	
138.05	6.25 kHz	3.571	Low Power
143.95		3.506	
148.05		3.558	
150.05		3.526	
162.05		3.479	
173.95		3.490	

Conducted 99% Bandwidth Measurements for 4K00F2D

4K00F2D Mode		Measured Bandwidth [kHz]	Setting
Frequency [MHz]	Channel bandwidth		
138.05	6.25 kHz	3.335	Low Power
143.95		3.334	
148.05		3.334	
150.05		3.336	
162.05		3.335	
173.95		3.330	

Plots of 99% Bandwidth

(16K0F3E _ 138.05 MHz)_High

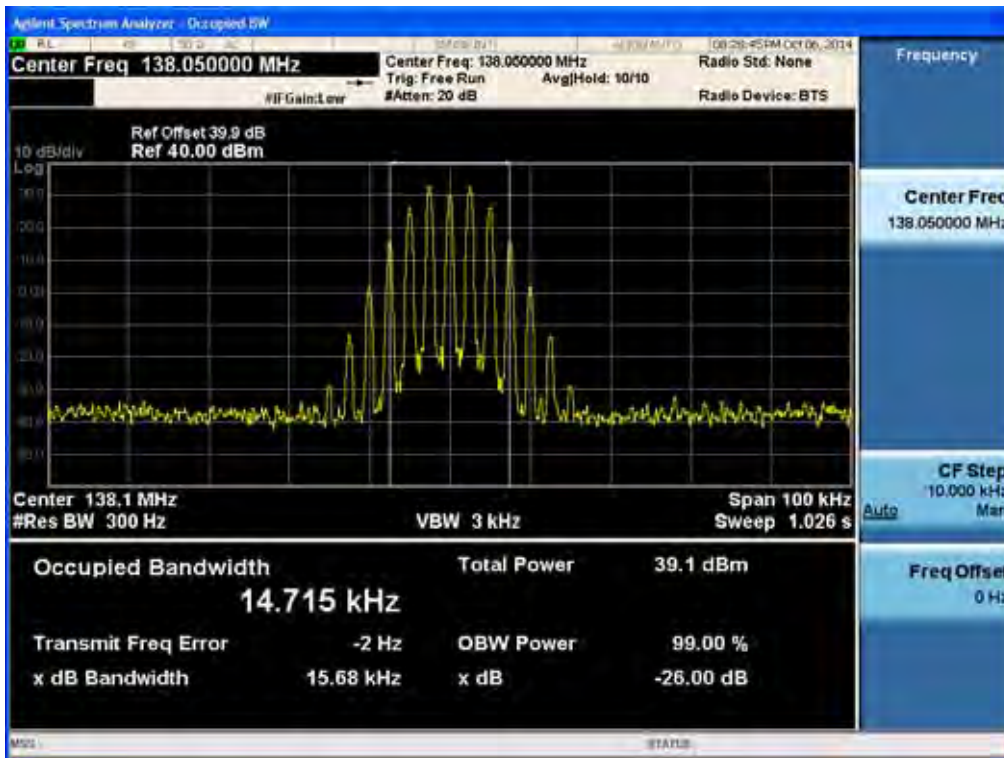

(16K0F3E _ 143.95 MHz)_High

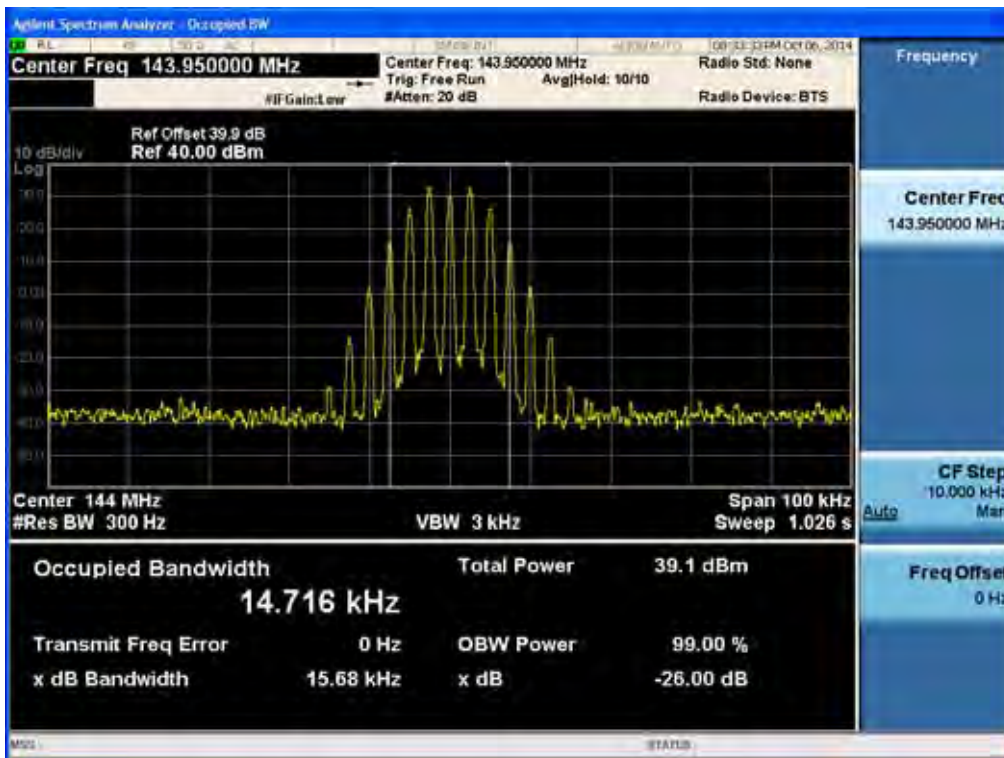

(16K0F3E _ 148.05 MHz)_High

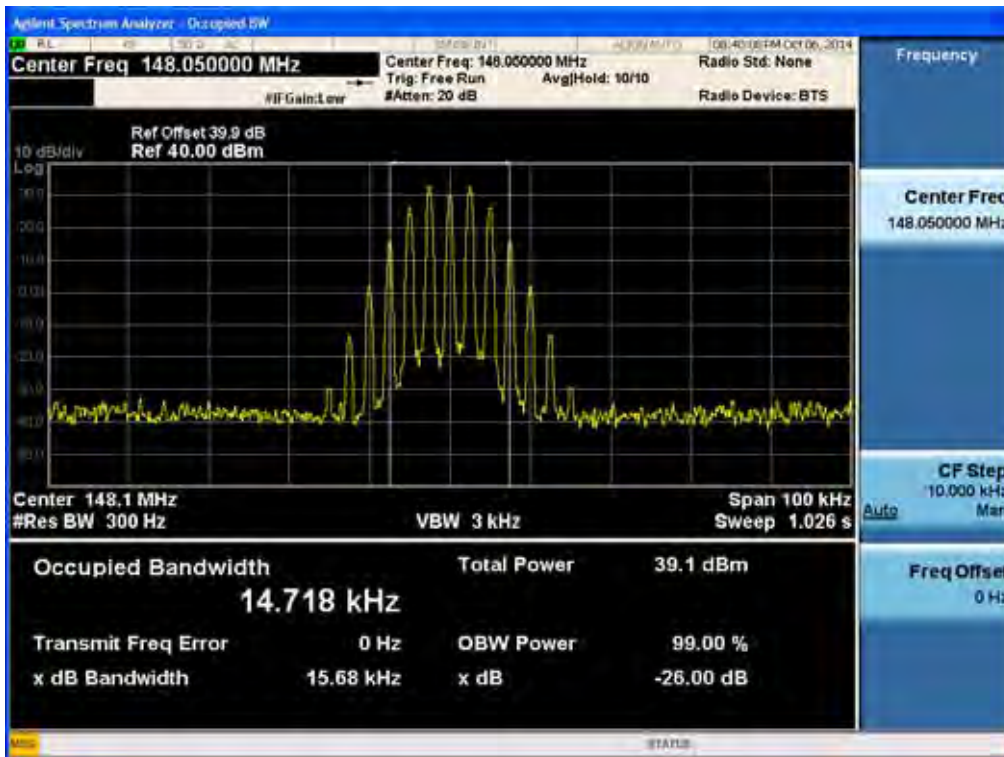

(16K0F3E _ 138.05 MHz)_Low

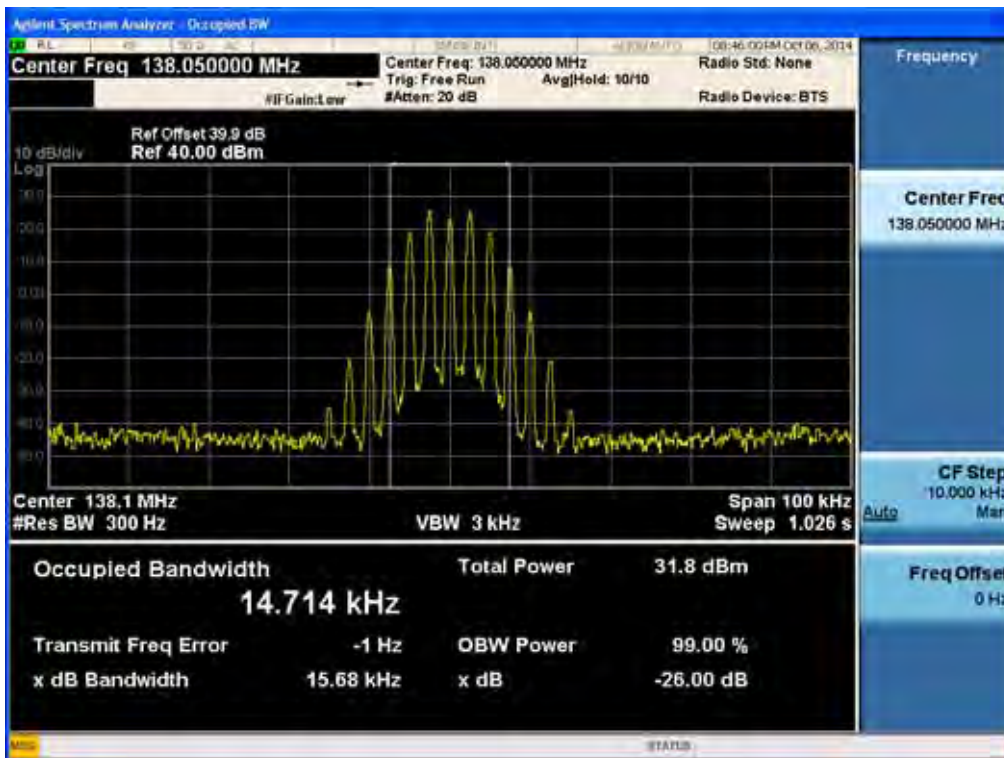

(16K0F3E _ 143.95 MHz)_Low



(16K0F3E _ 148.05 MHz)_Low

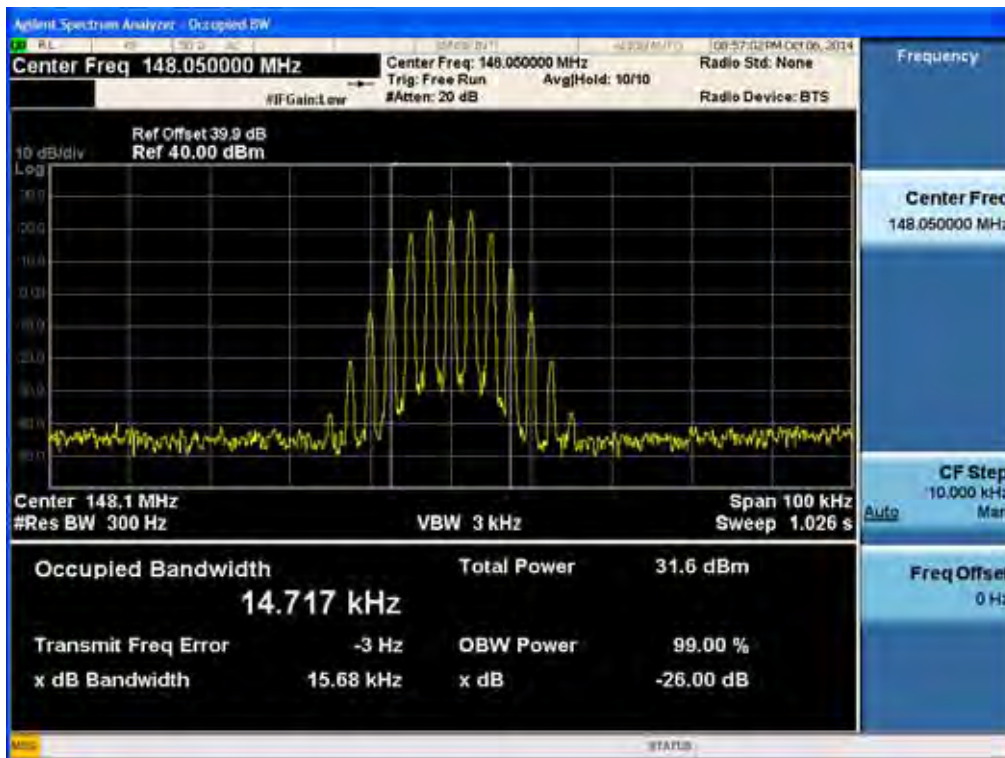

(11K0F3E _ 138.05 MHz)_High

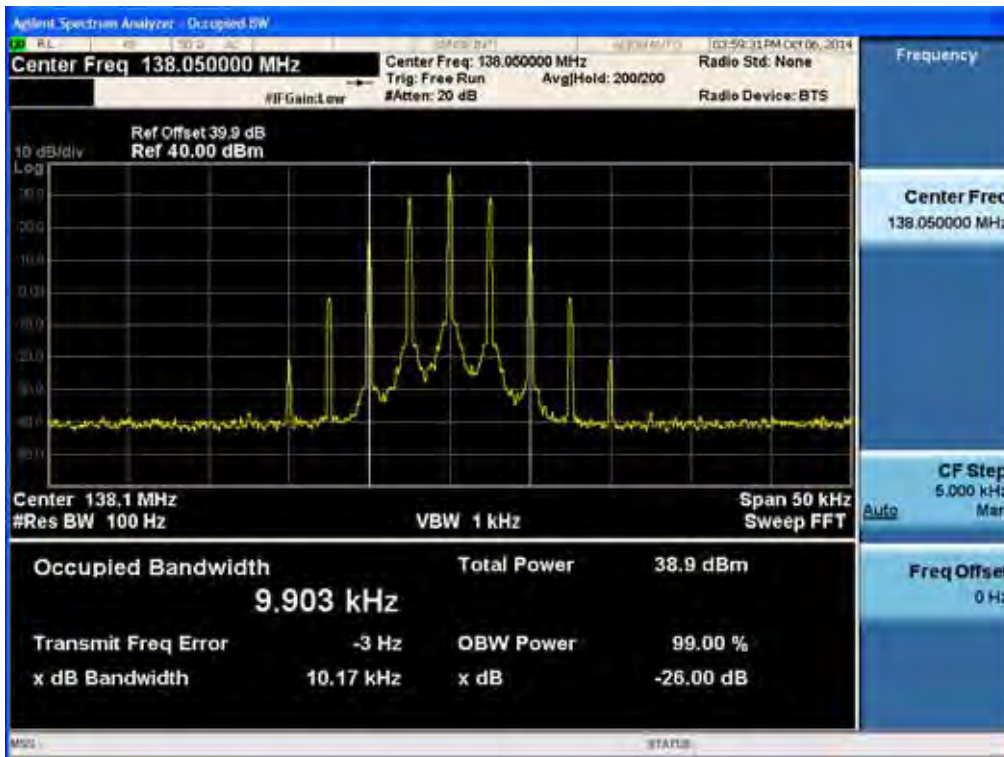

(11K0F3E _ 143.95 MHz)_High

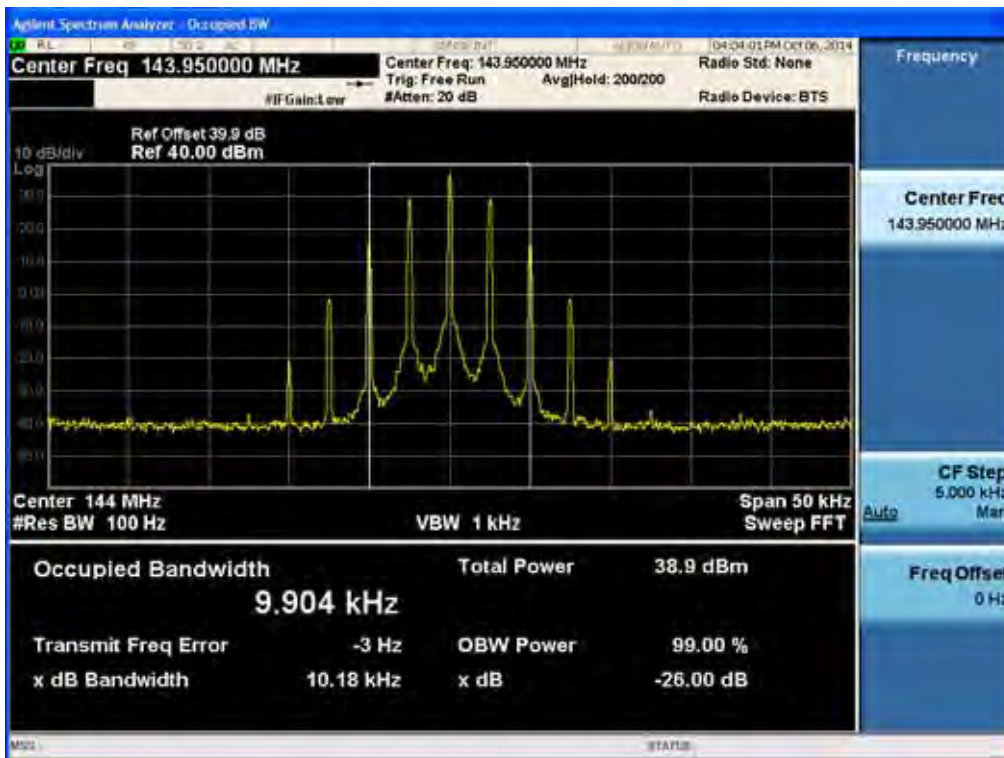

(11K0F3E _ 148.05 MHz)_High

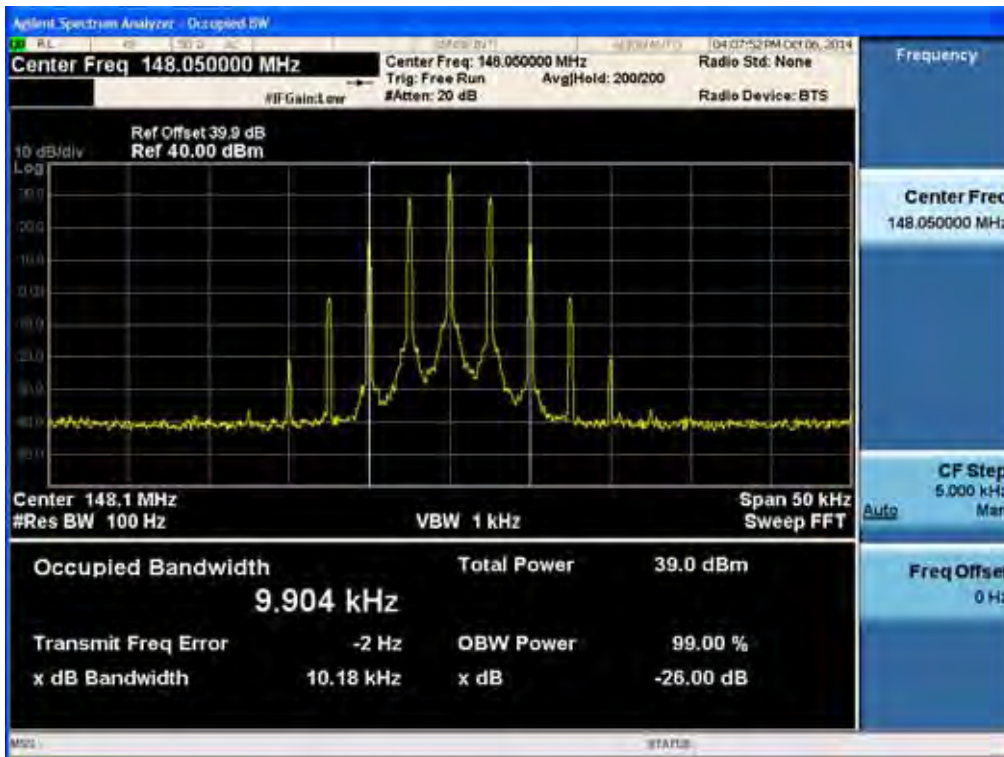

(11K0F3E _ 150.05 MHz)_High

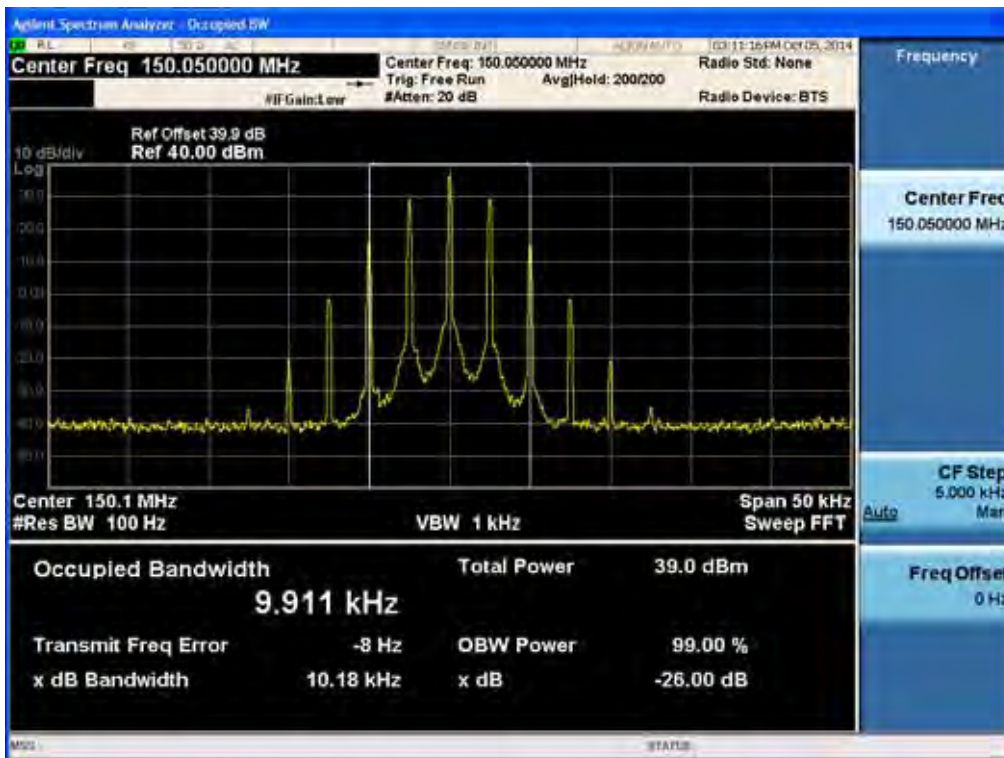

(11K0F3E _ 162.05 MHz)_High

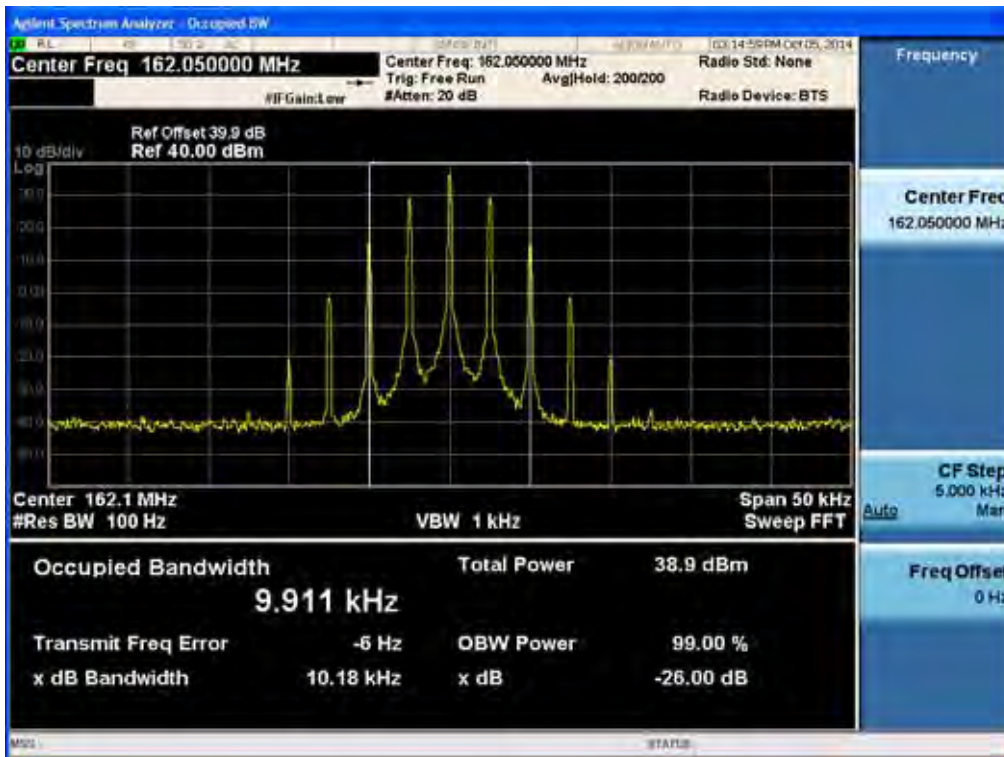

(11K0F3E _ 173.95 MHz)_High

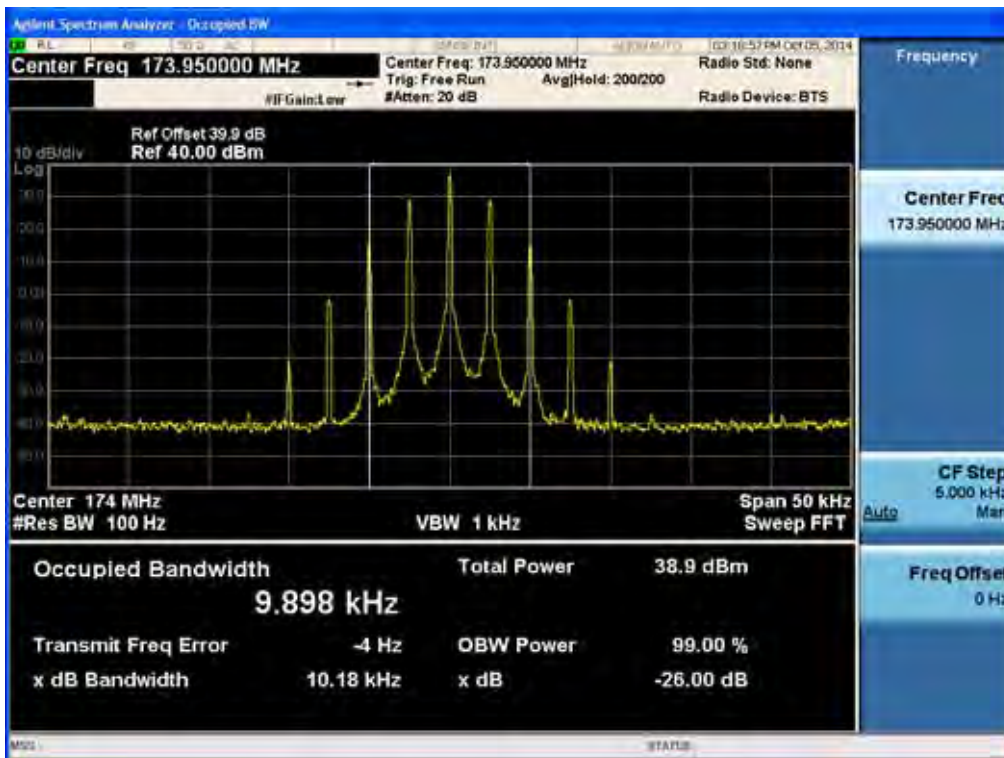

(11K0F3E _ 138.05 MHz)_Low

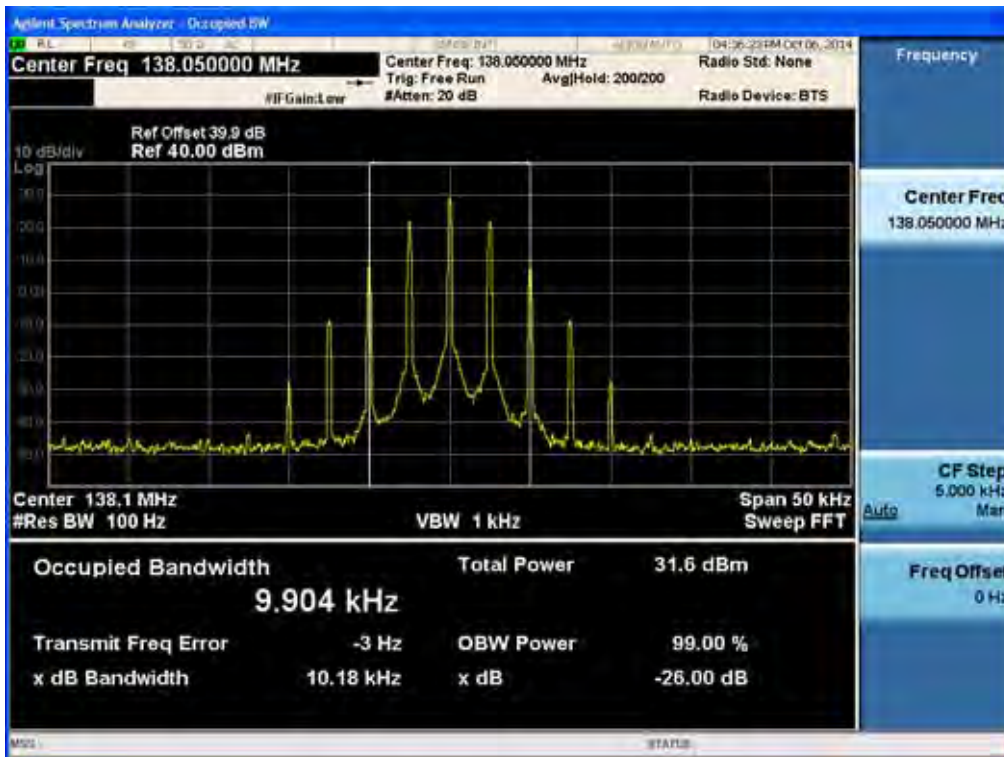

(11K0F3E _ 143.95 MHz)_Low

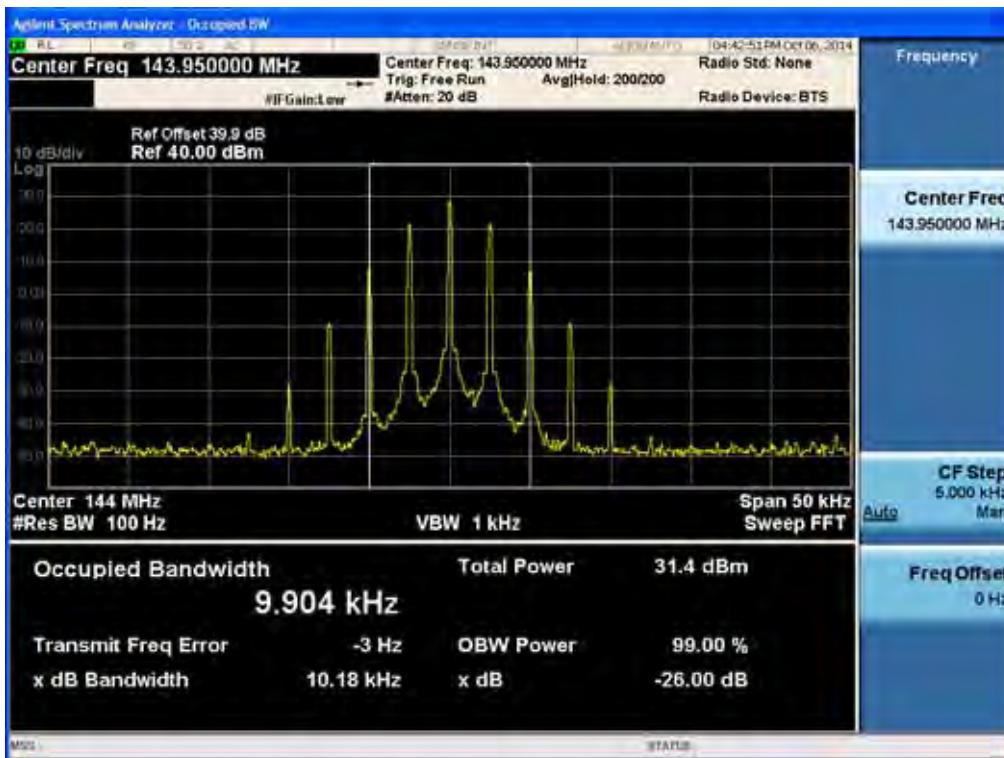

(11K0F3E _ 148.05 MHz)_Low

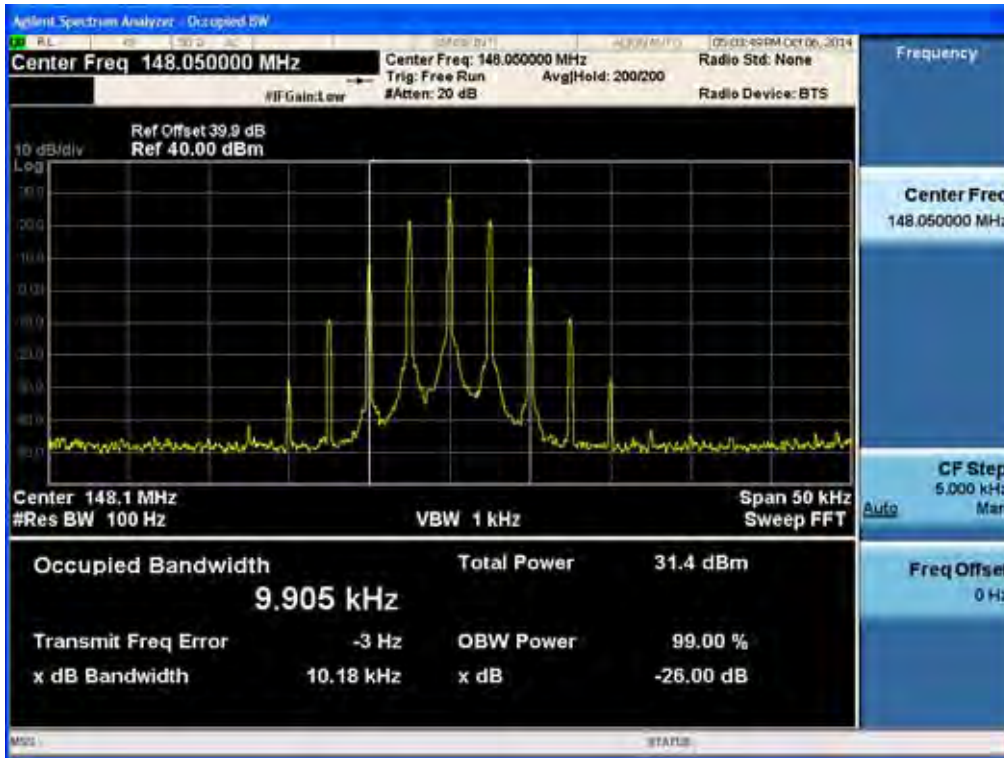

(11K0F3E _ 150.05 MHz)_Low

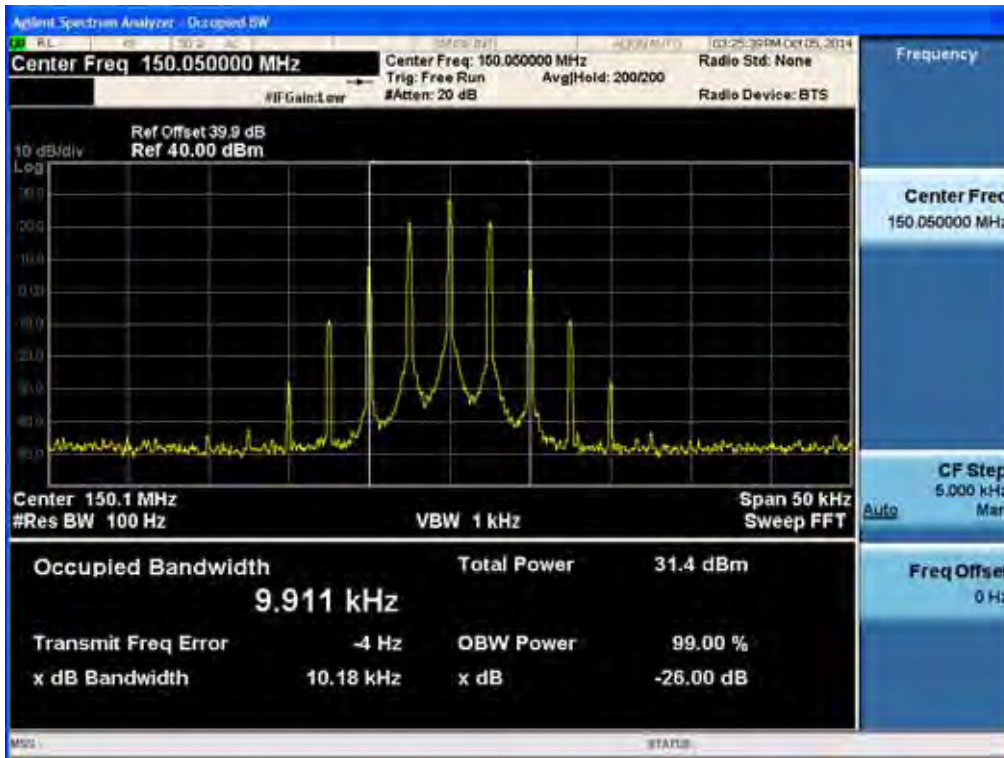

(11K0F3E _ 162.05 MHz)_Low

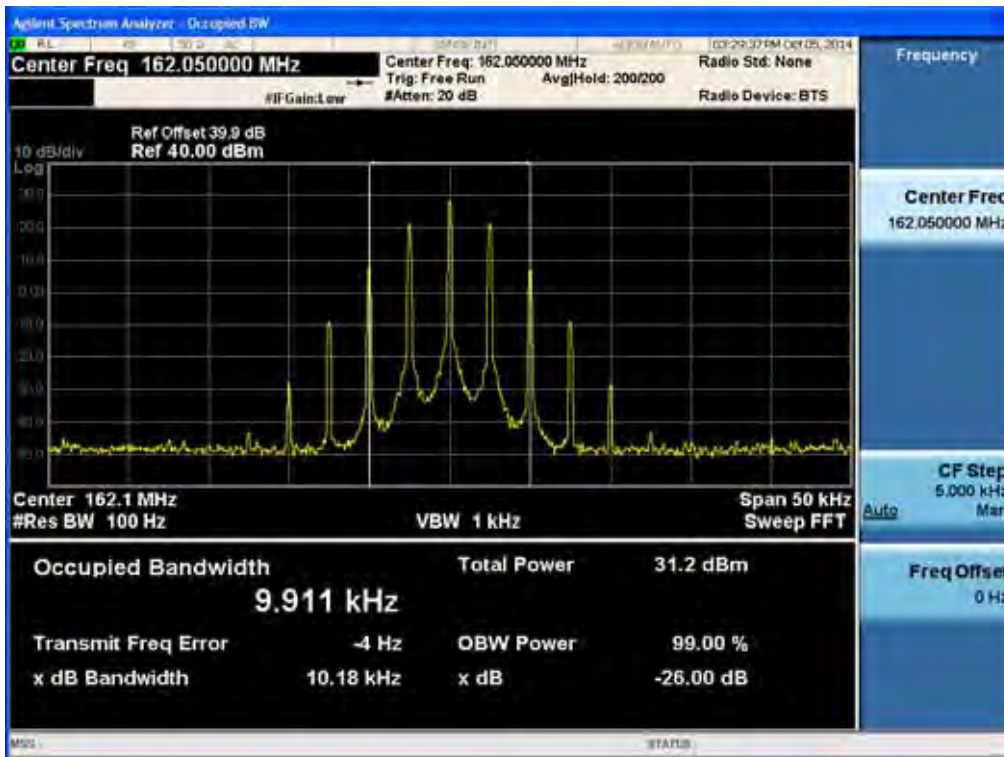

(11K0F3E _ 173.95 MHz)_Low

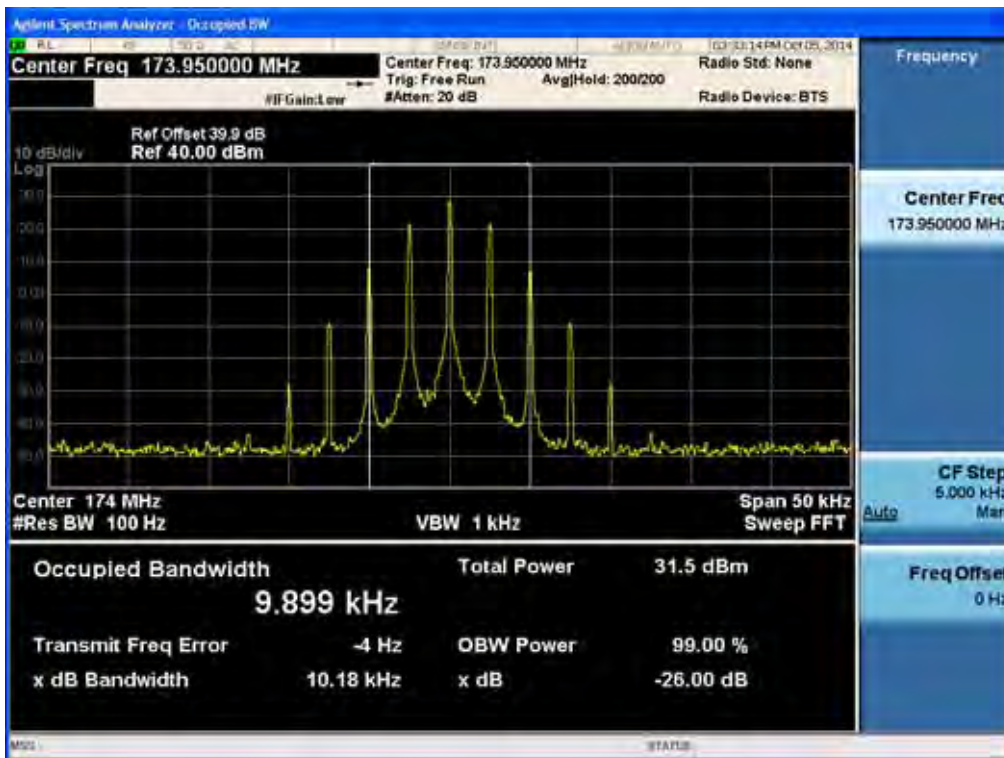

(8K10F1E, 8K10F1D _ 138.05 MHz)_High

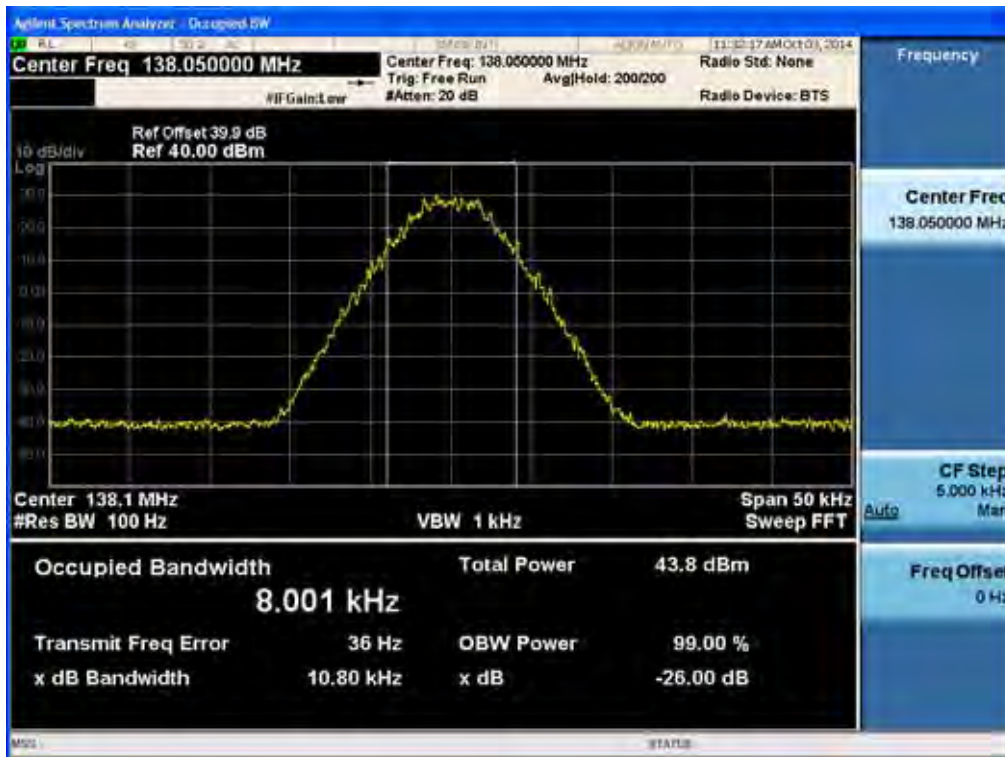

(8K10F1E, 8K10F1D _ 143.95 MHz)_High

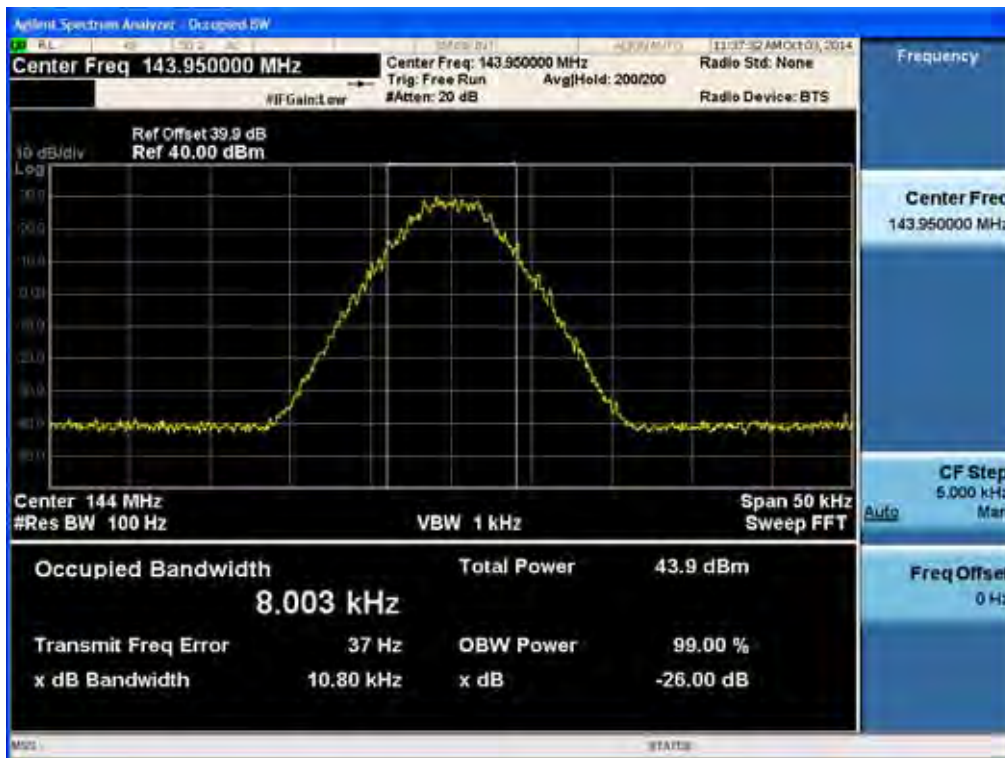

(8K10F1E, 8K10F1D _ 148.05 MHz)_High

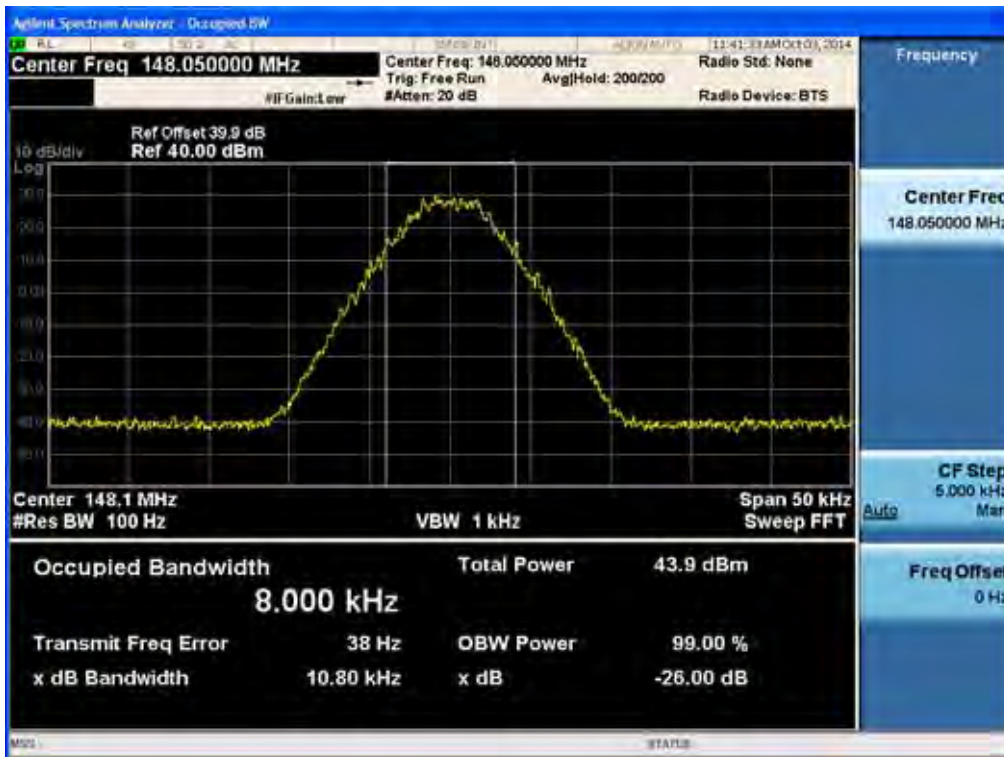

(8K10F1E, 8K10F1D _ 150.05 MHz)_High

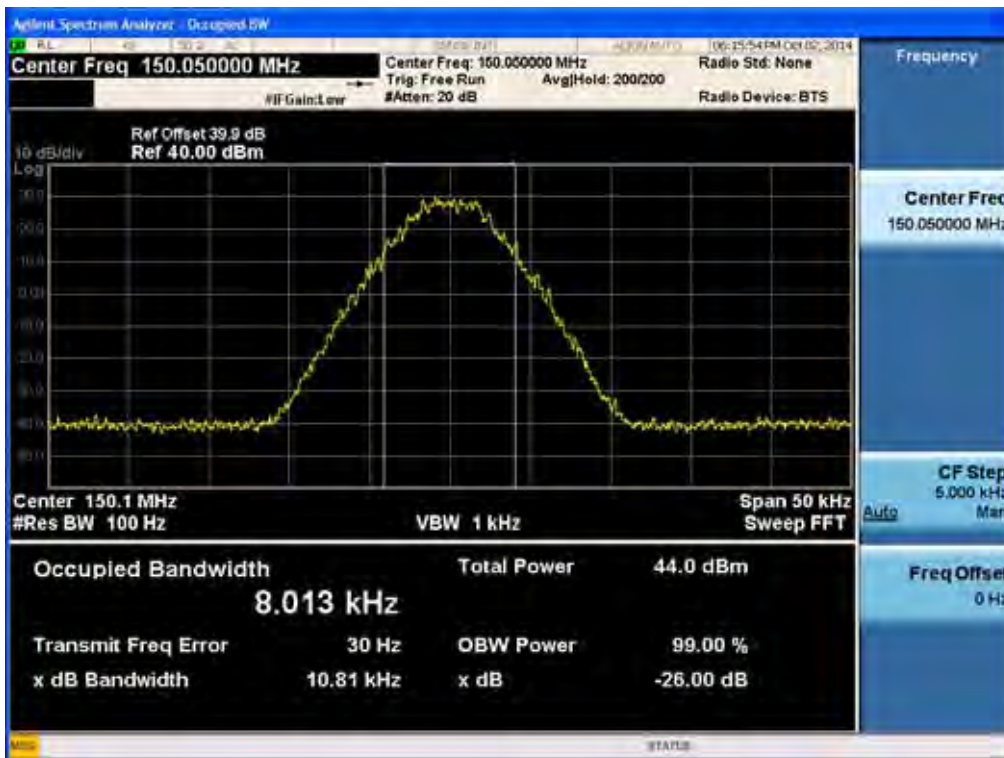

(8K10F1E, 8K10F1D _ 162.05 MHz)_High

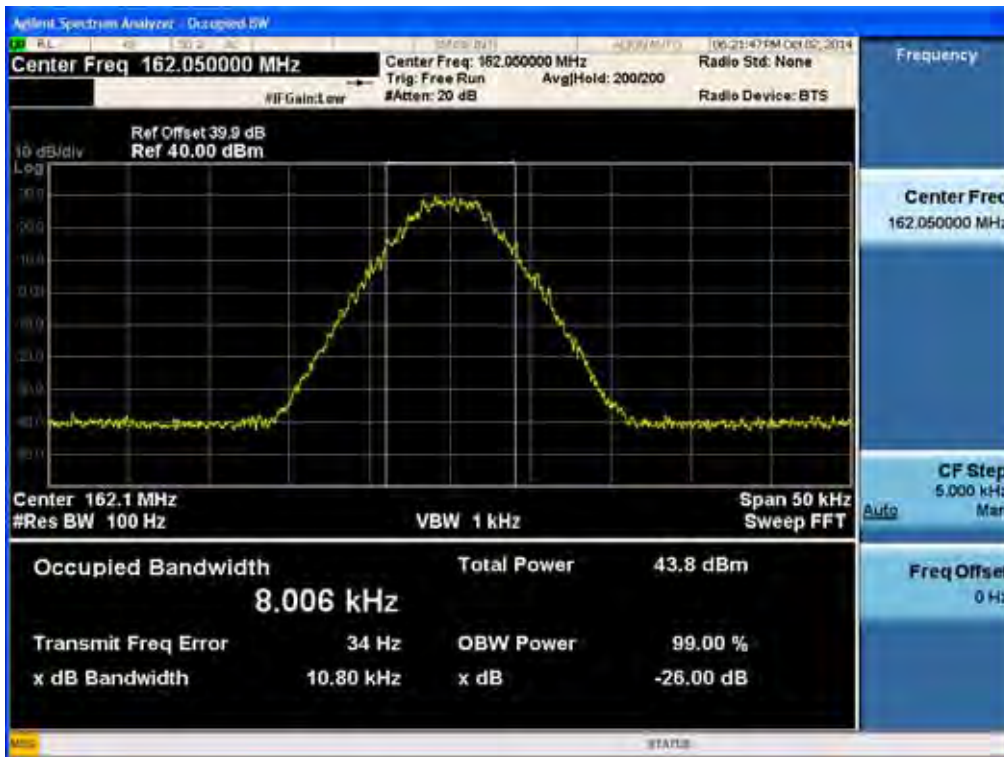

(8K10F1E, 8K10F1D _ 173.95 MHz)_High

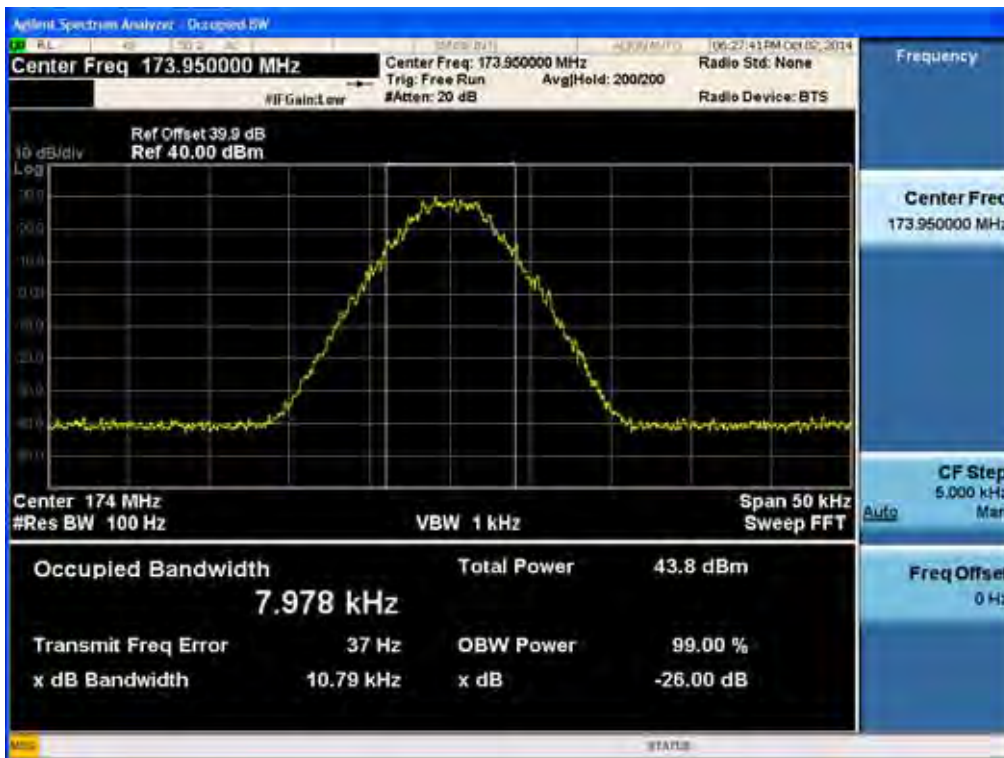

(8K10F1E, 8K10F1D _ 138.05 MHz)_Low

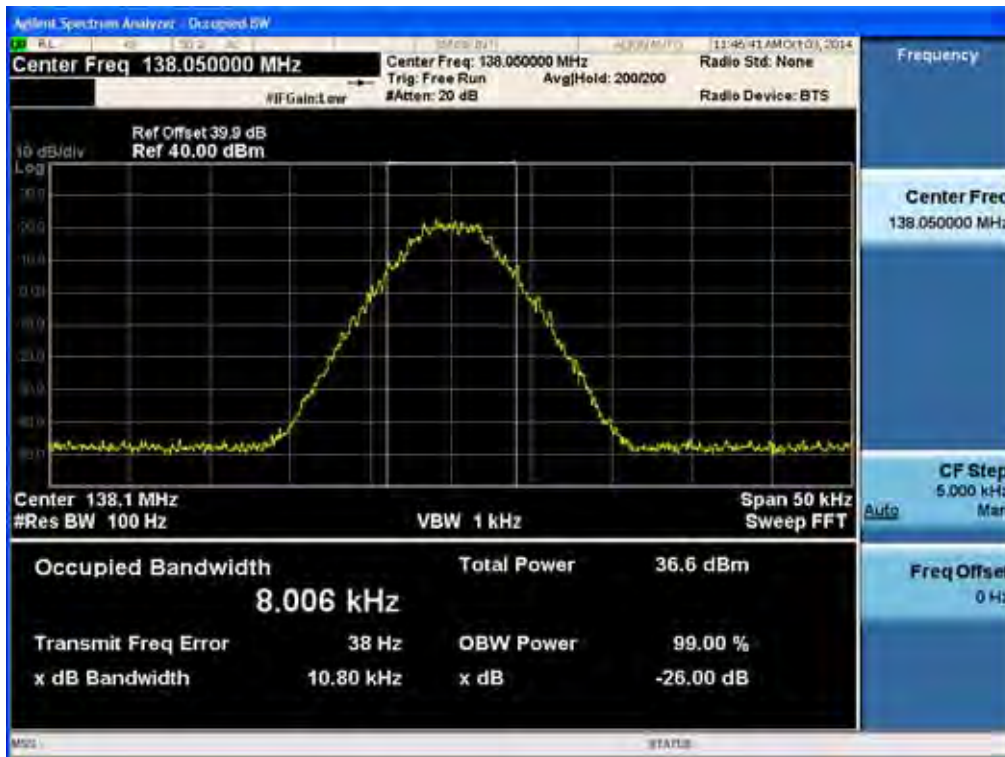

(8K10F1E, 8K10F1D _ 143.95 MHz)_Low

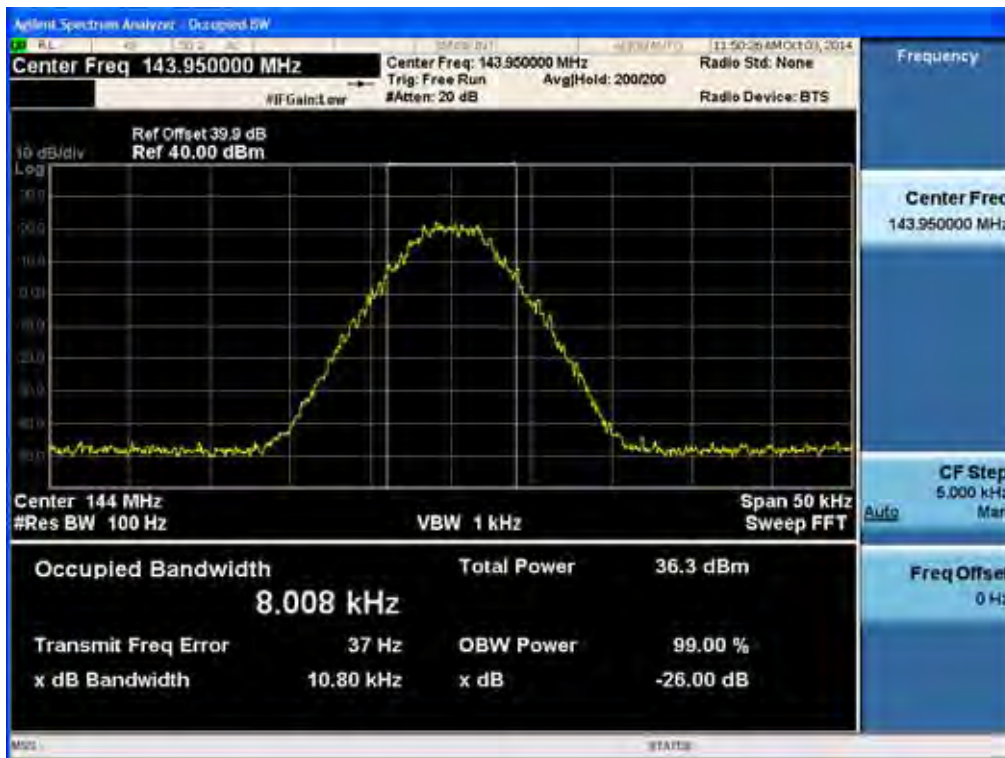

(8K10F1E, 8K10F1D _ 148.05 MHz)_Low

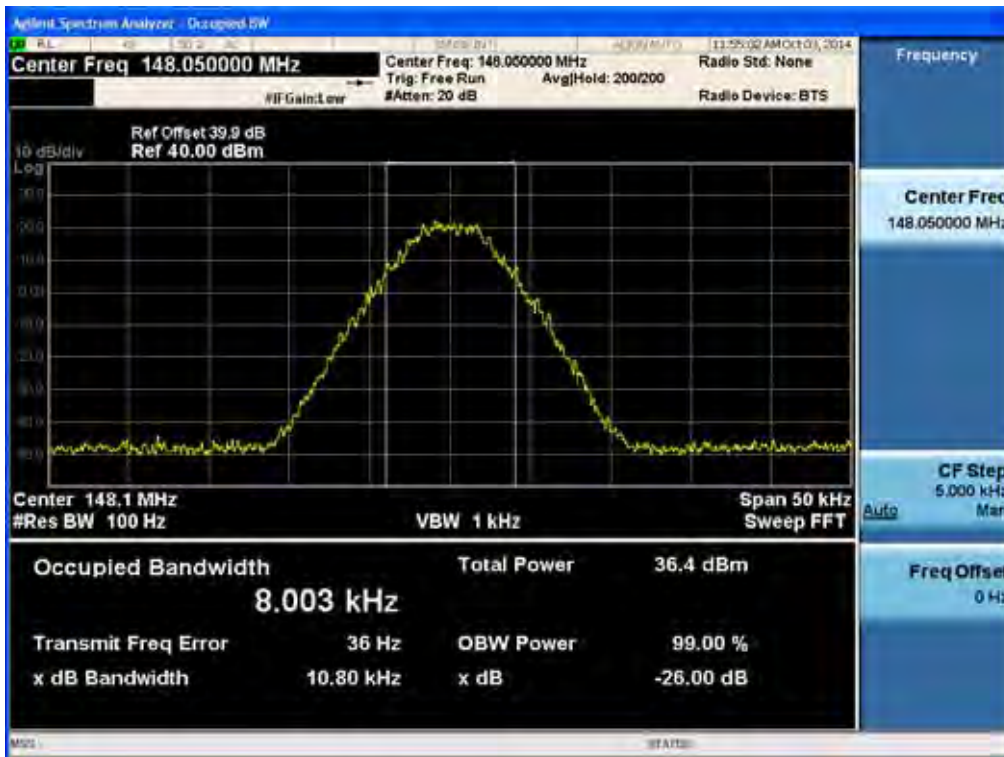

(8K10F1E, 8K10F1D _ 150.05 MHz)_Low

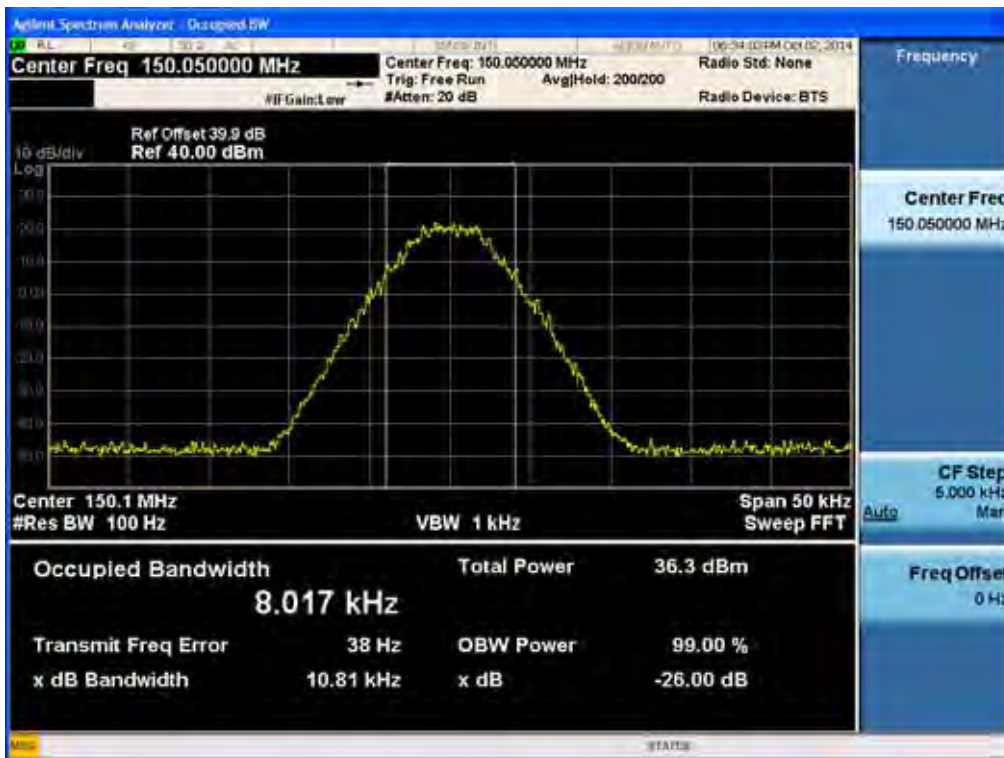

(8K10F1E, 8K10F1D _ 162.05 MHz)_Low

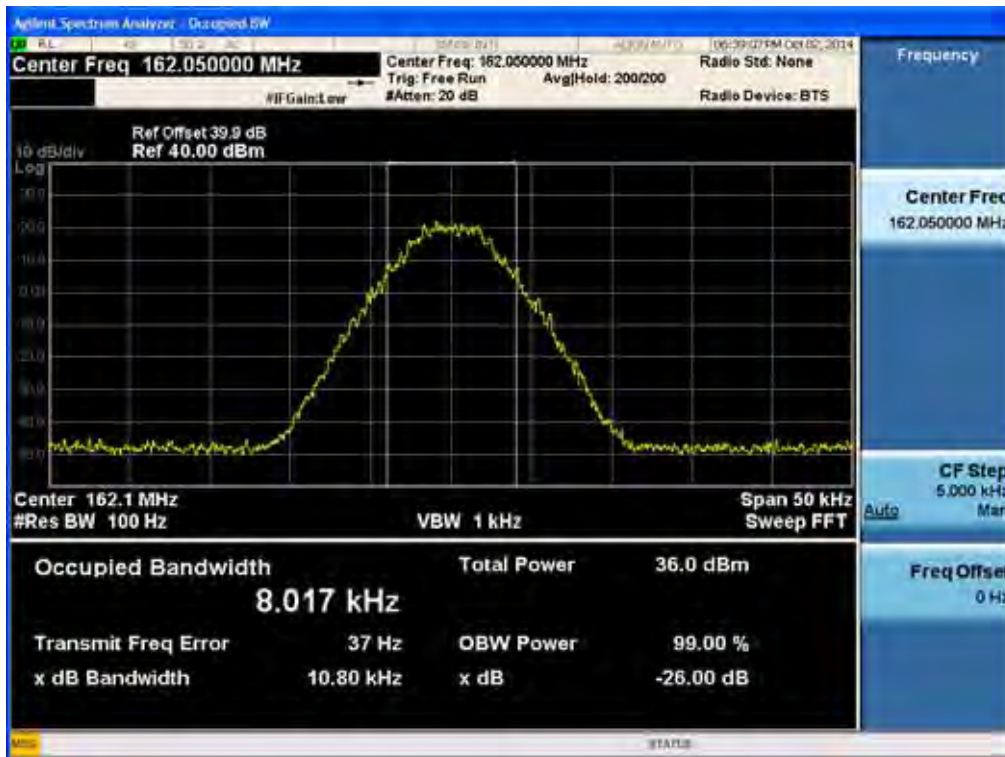

(8K10F1E, 8K10F1D _ 173.95 MHz)_Low

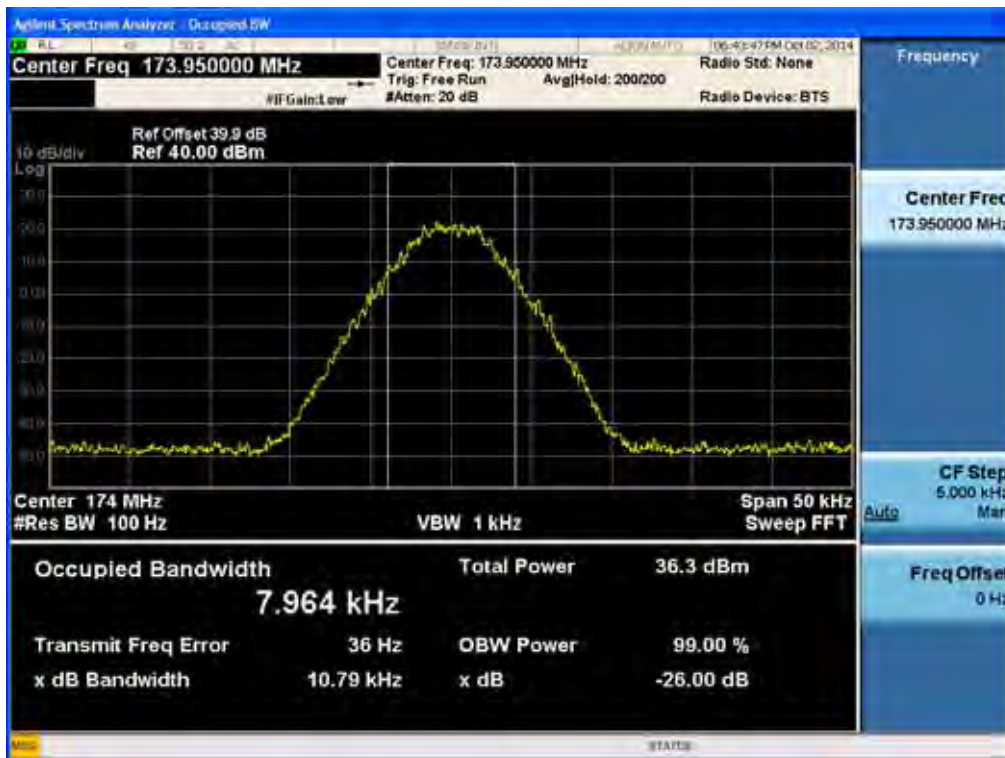

(8K10F1W _ 138.05 MHz)_High



(8K10F1W _ 143.95 MHz)_High

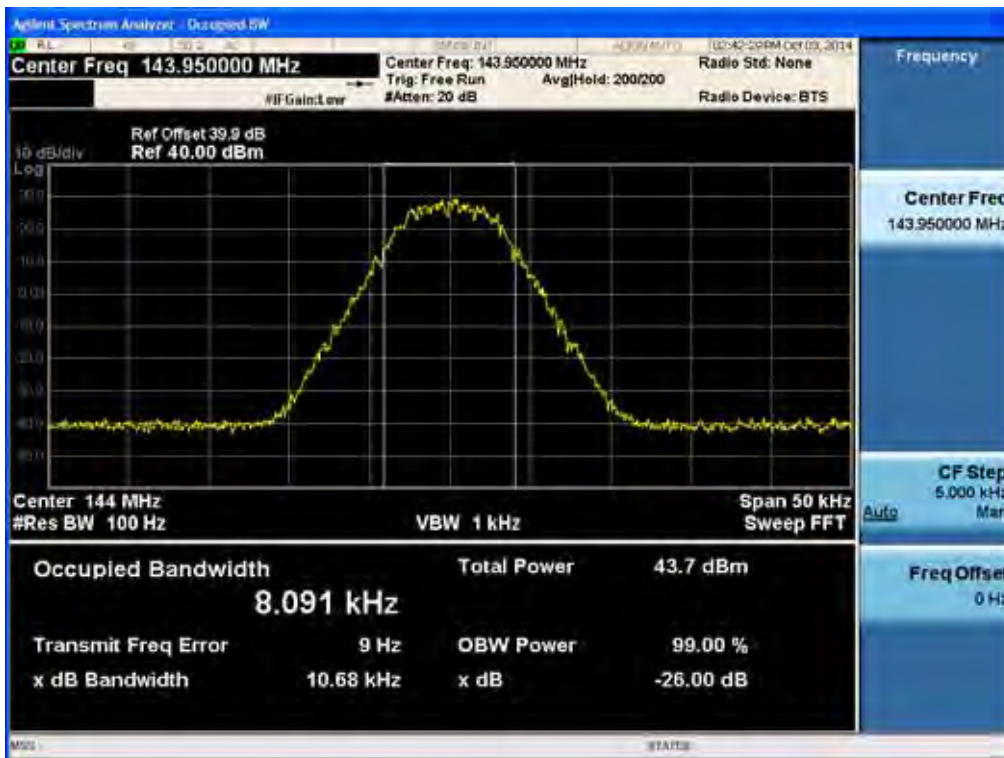

(8K10F1W _ 148.05 MHz)_High

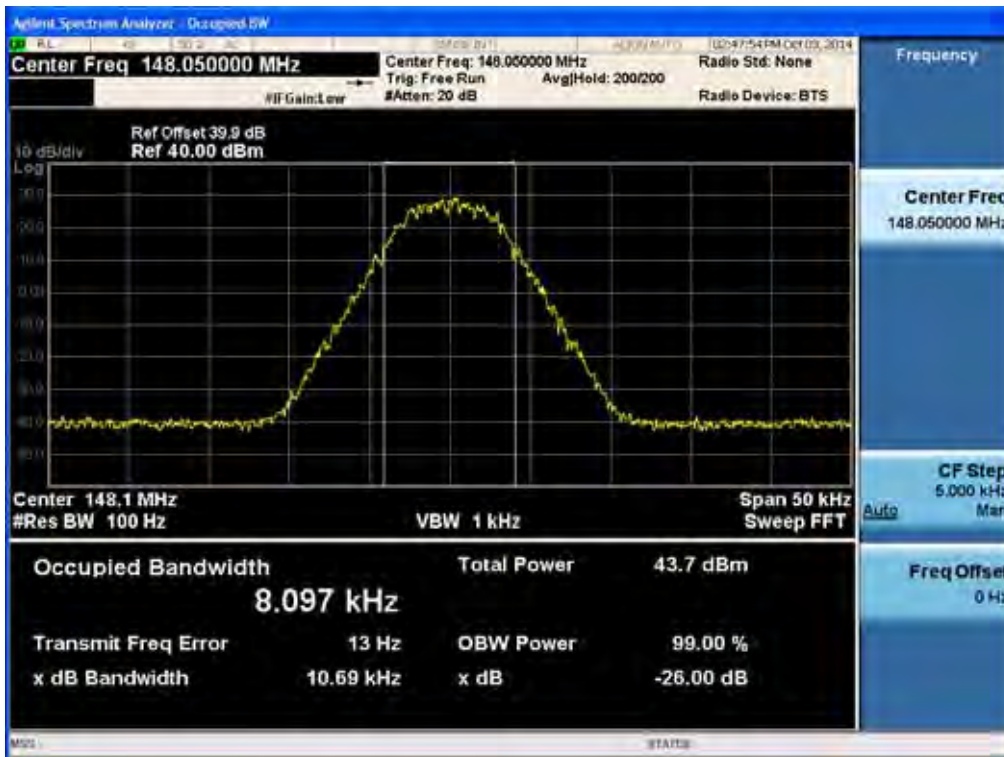

(8K10F1W _ 150.05 MHz)_High

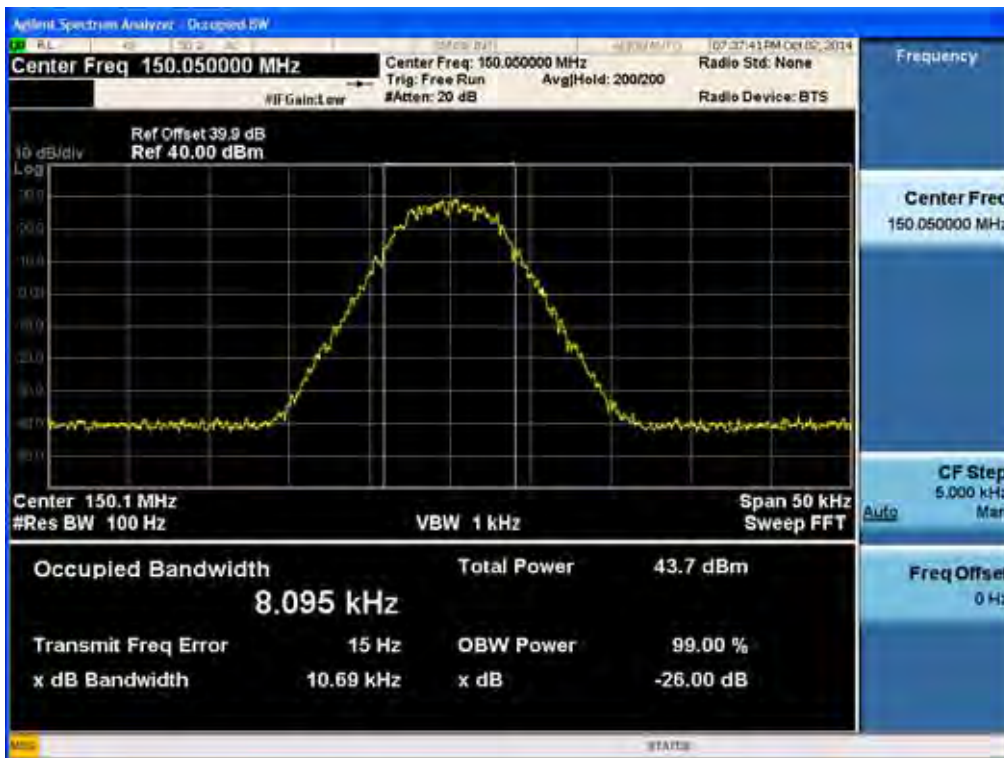

(8K10F1W _ 162.05 MHz)_High



(8K10F1W _ 173.95 MHz)_High

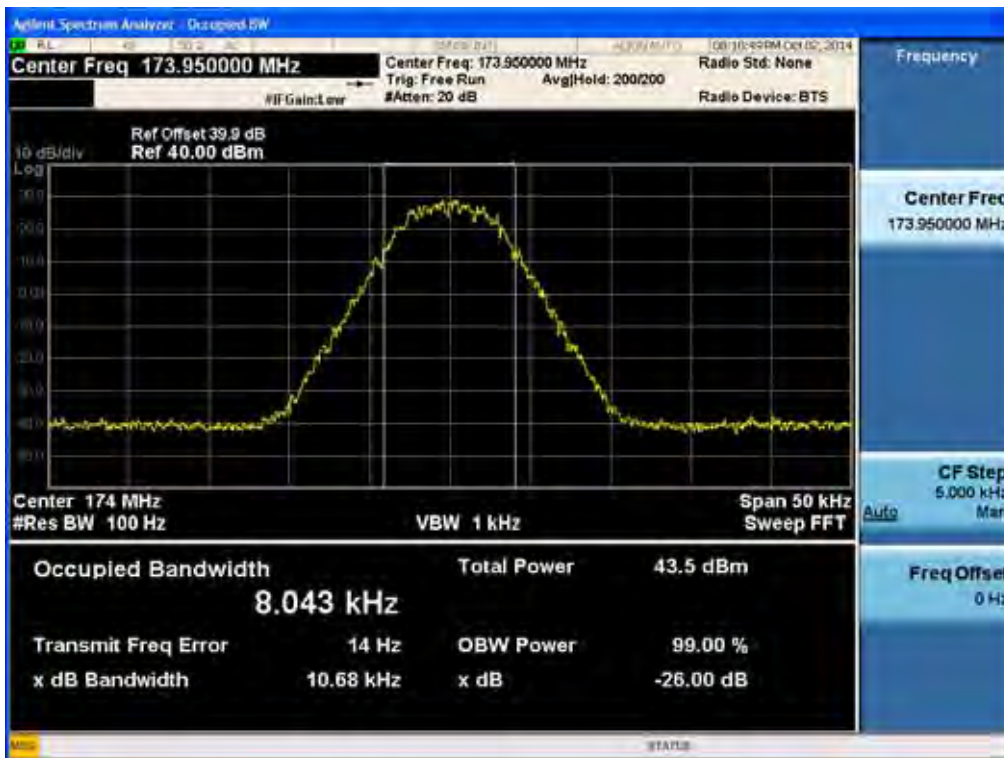

(8K10F1W _ 138.05 MHz)_Low

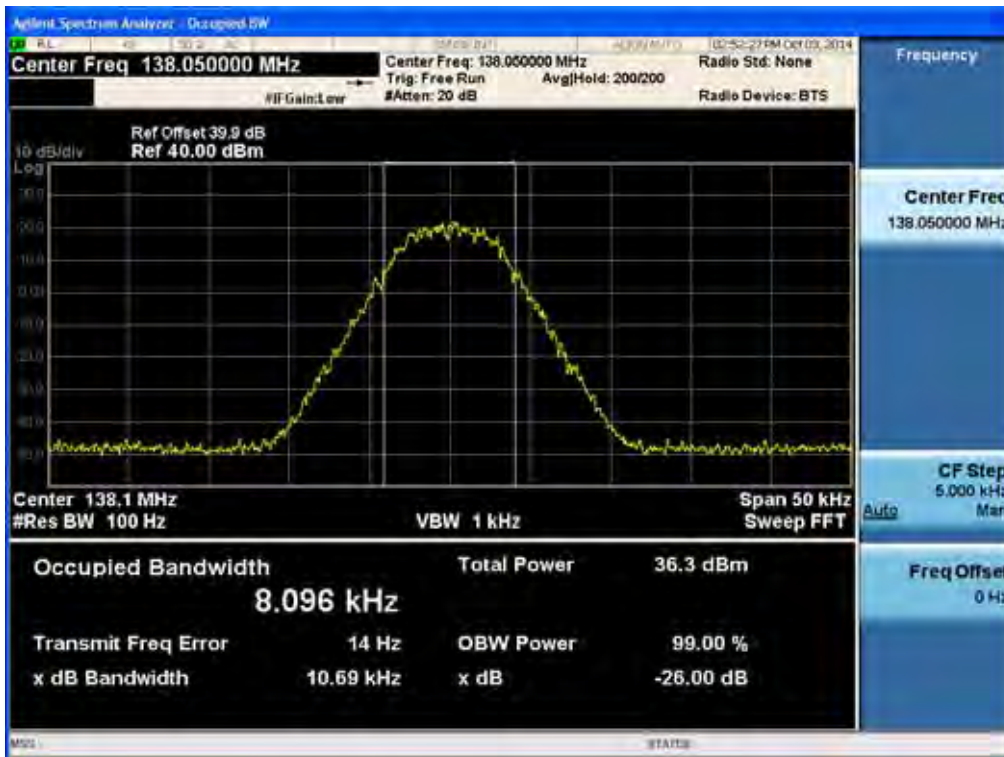

(8K10F1W _ 143.95 MHz)_Low

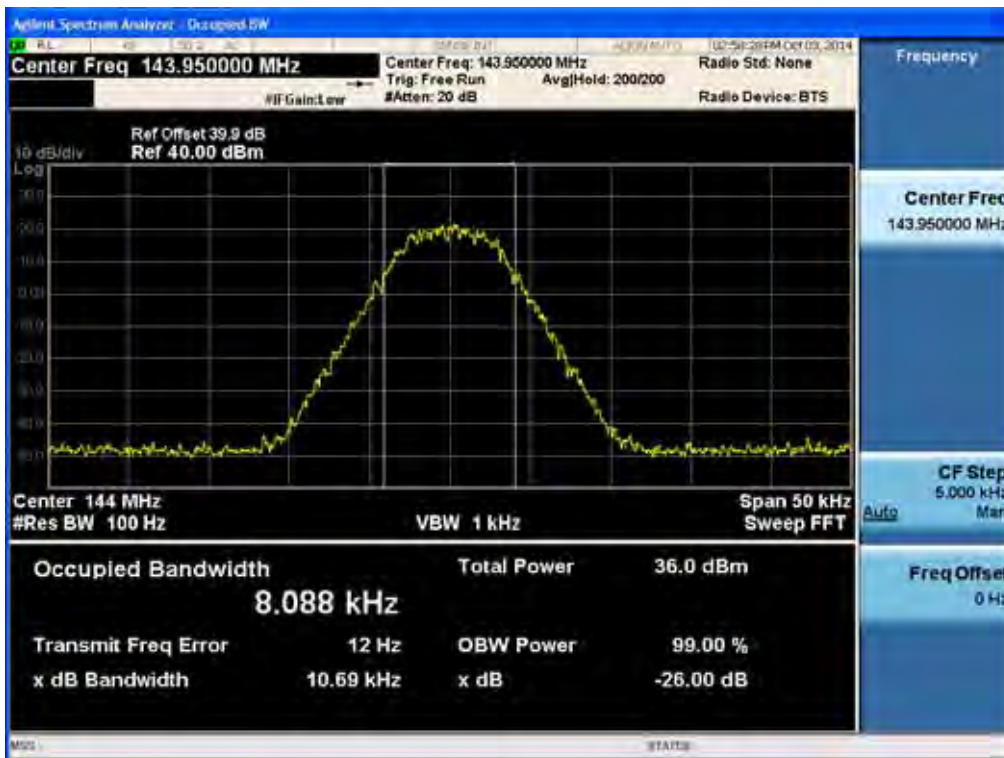

(8K10F1W _ 148.05 MHz)_Low

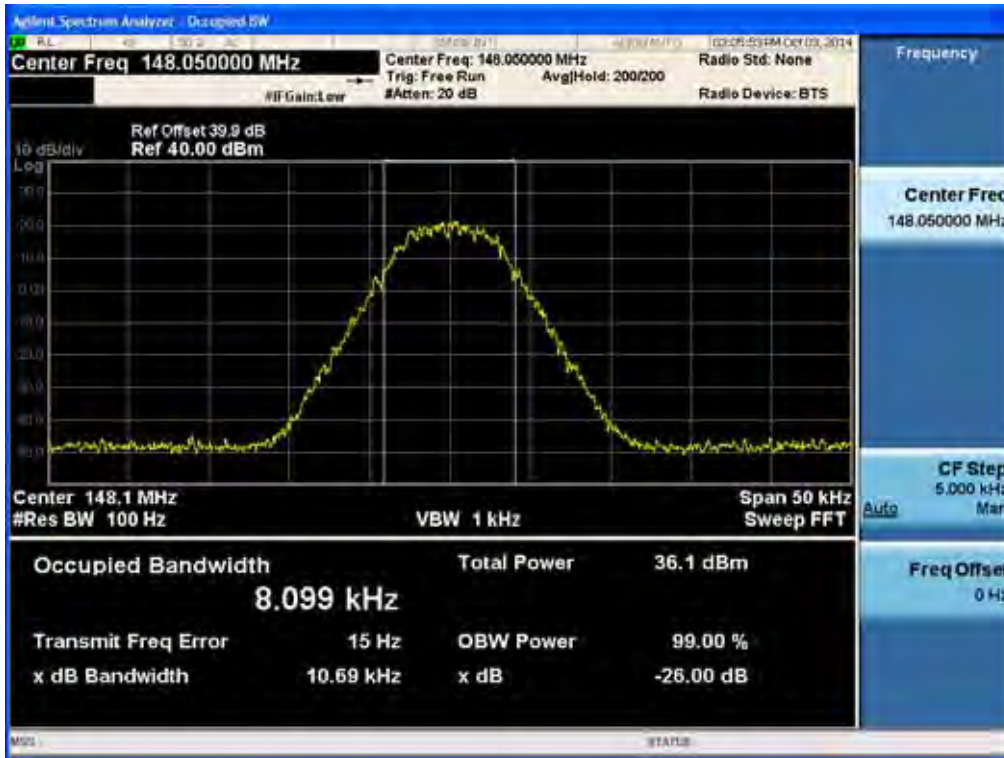

(8K10F1W _ 150.05 MHz)_Low

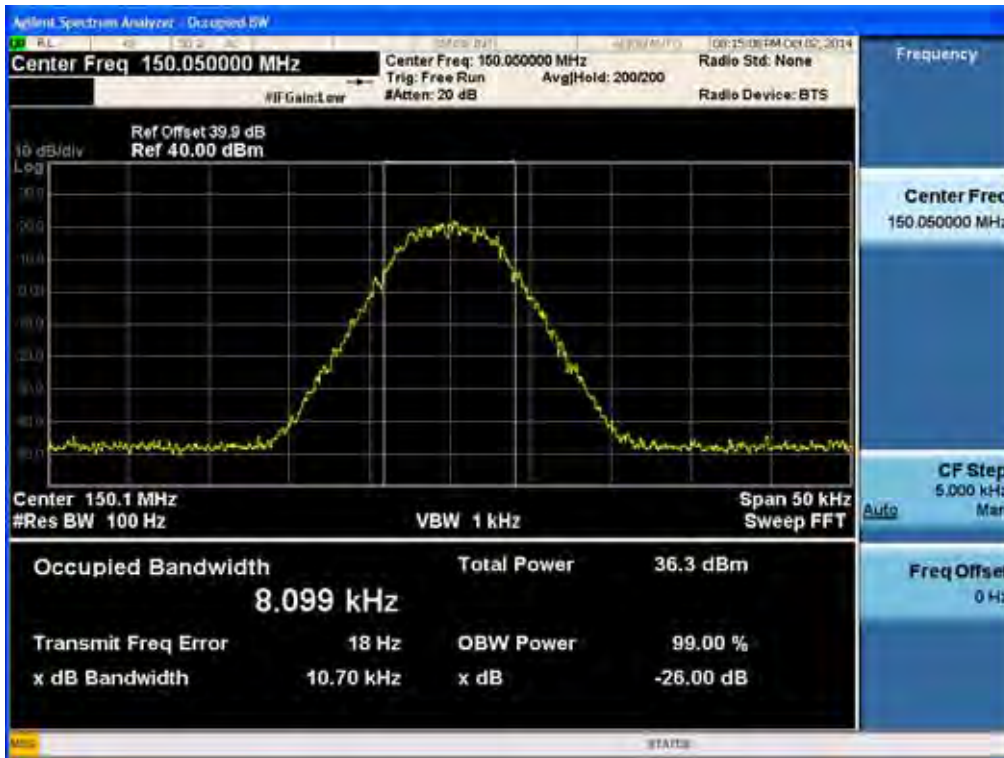

(8K10F1W _ 162.05 MHz)_Low

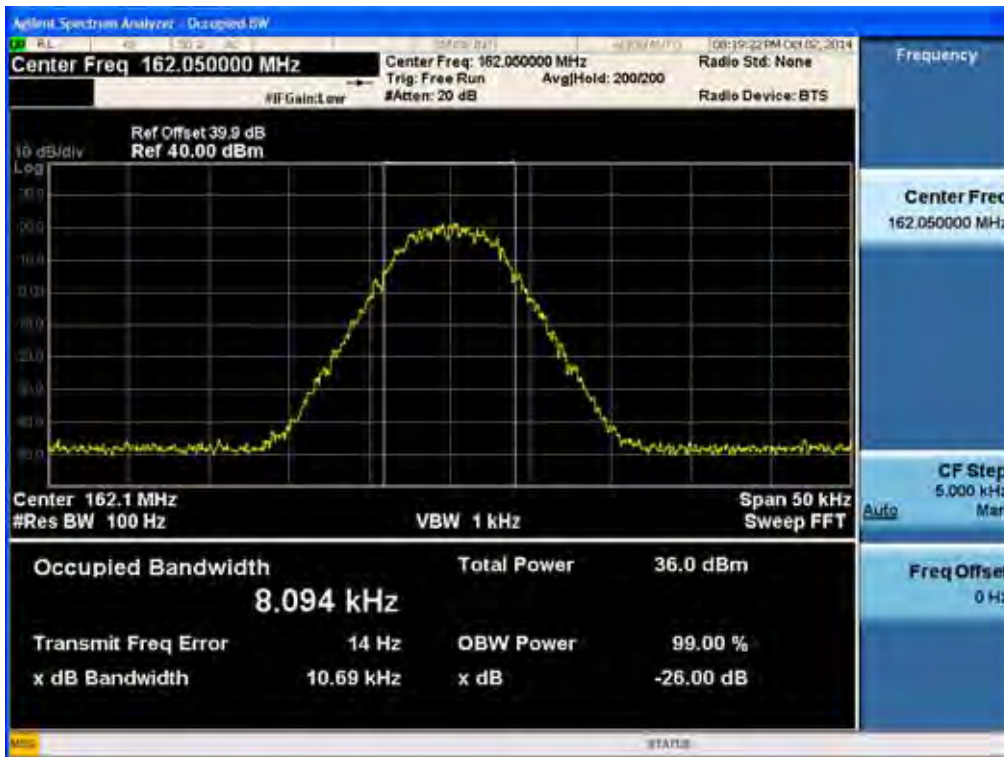

(8K10F1W _ 173.95 MHz)_Low

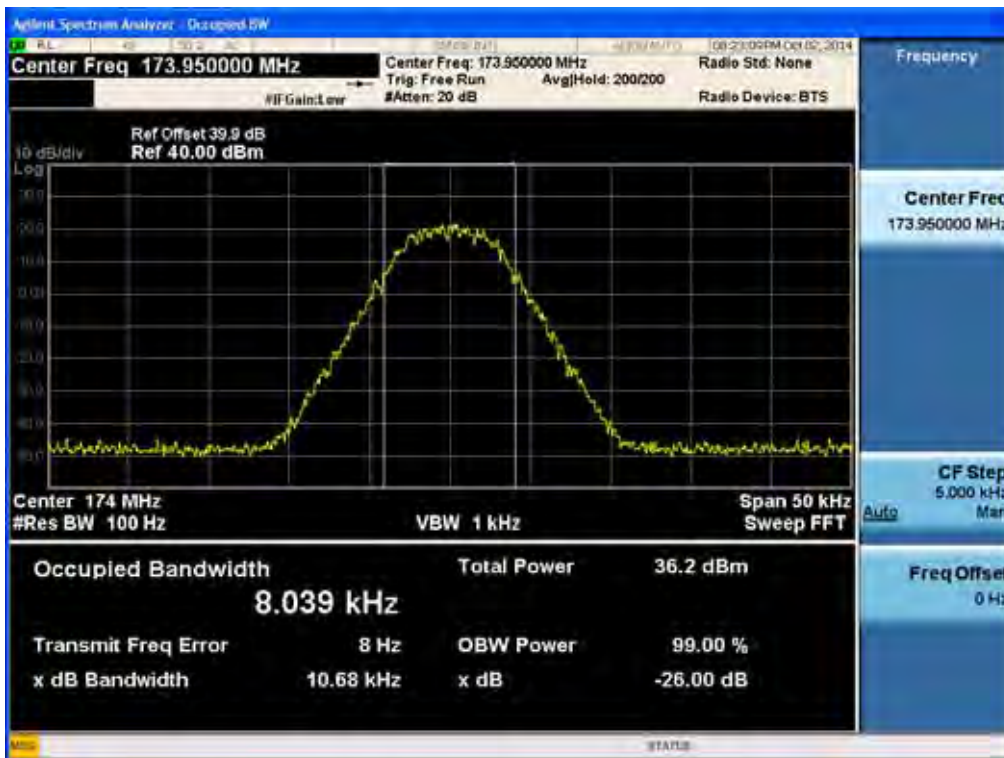

(8K30F1E, 8K30F1D, 8K30F7W _ 138.05 MHz)_High



(8K30F1E, 8K30F1D, 8K30F7W _ 143.95 MHz)_High

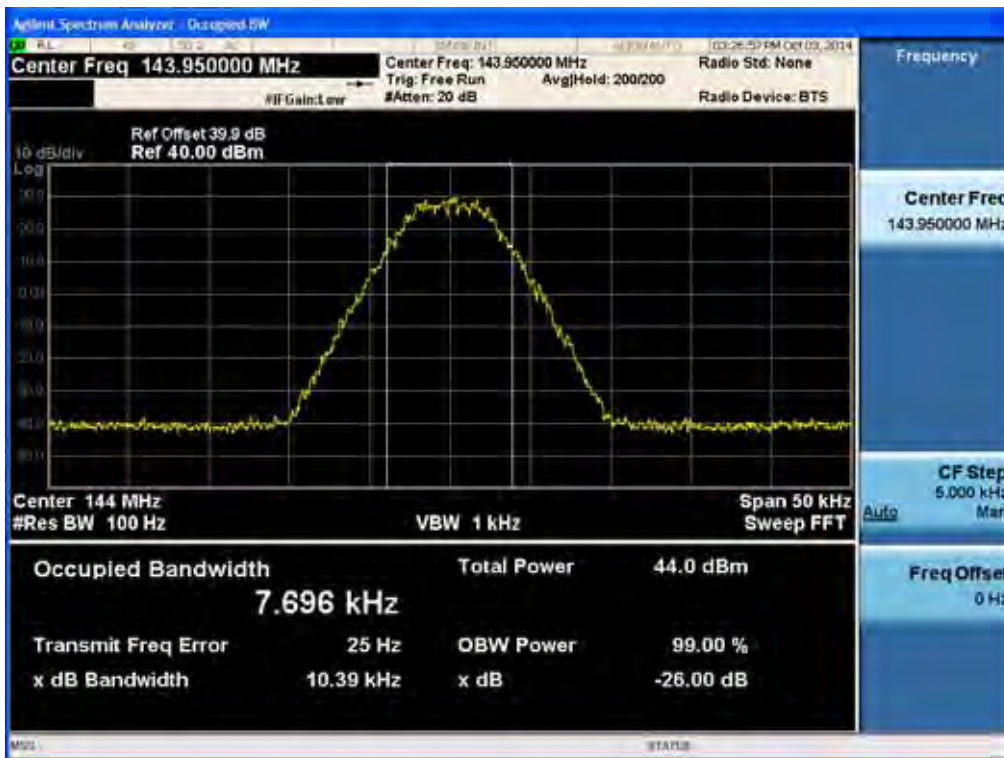

(8K30F1E, 8K30F1D, 8K30F7W _ 148.05 MHz)_High

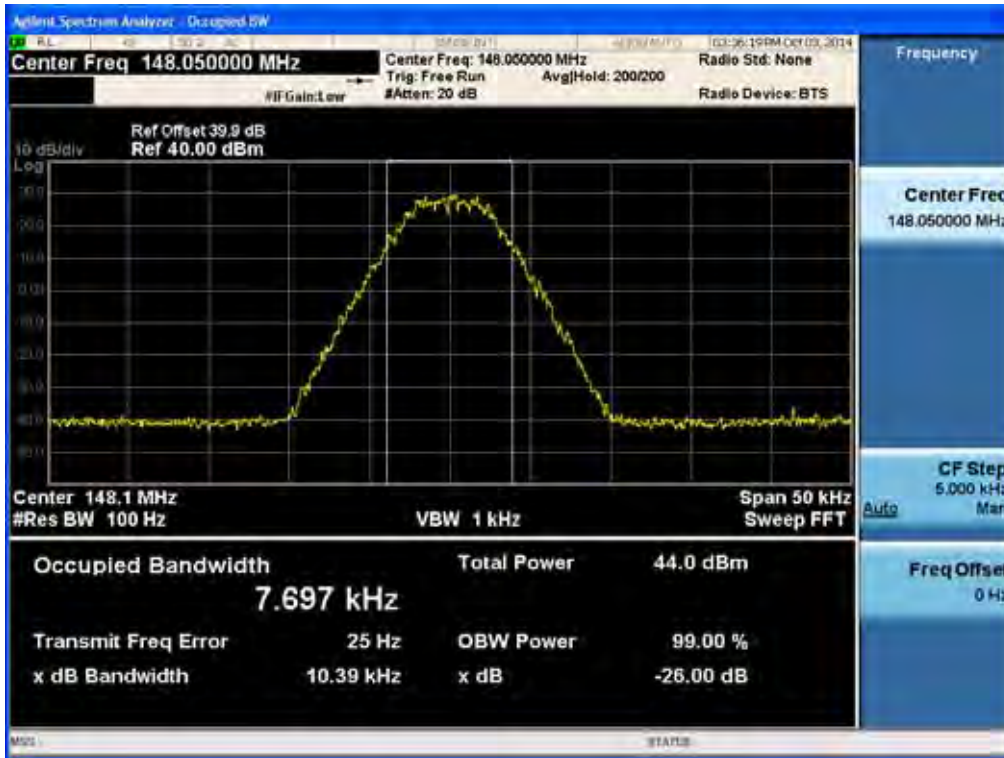

(8K30F1E, 8K30F1D, 8K30F7W _ 150.05 MHz)_High

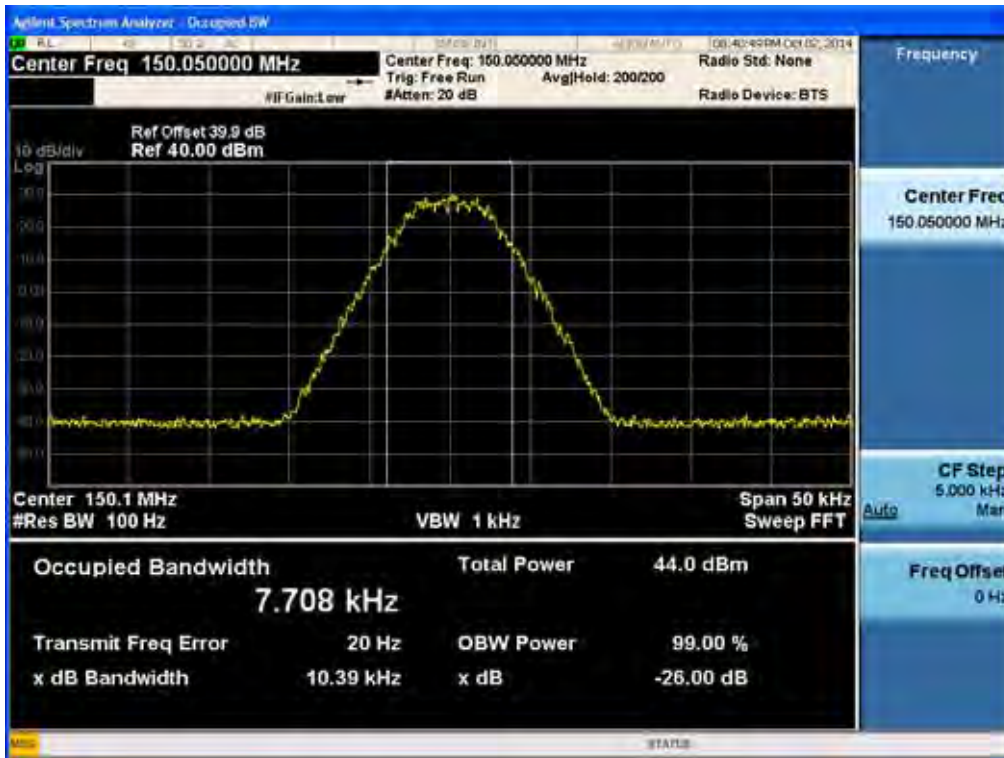

(8K30F1E, 8K30F1D, 8K30F7W _ 162.05 MHz)_High

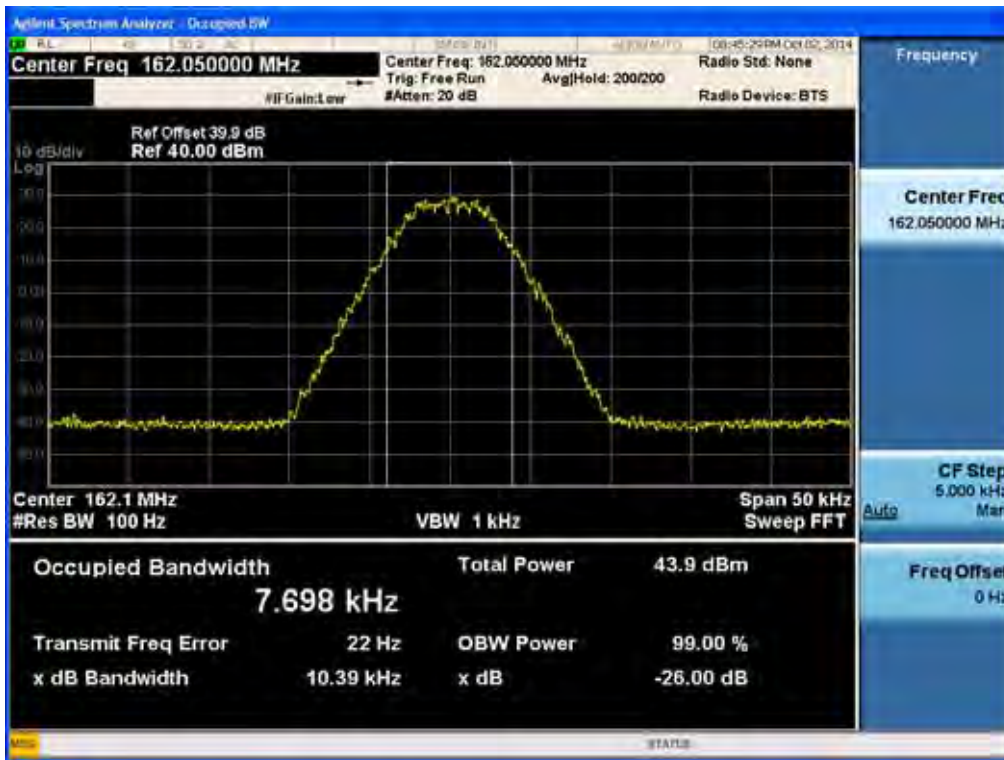

(8K30F1E, 8K30F1D, 8K30F7W _ 173.95 MHz)_High

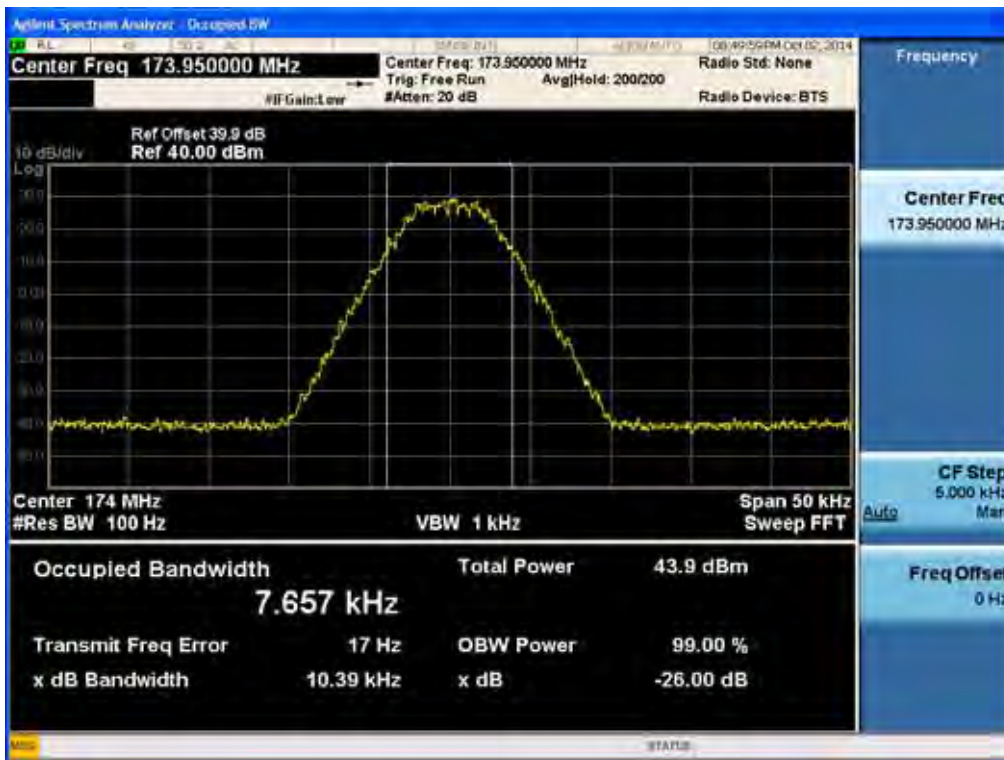

(8K30F1E, 8K30F1D, 8K30F7W _ 138.05 MHz)_Low

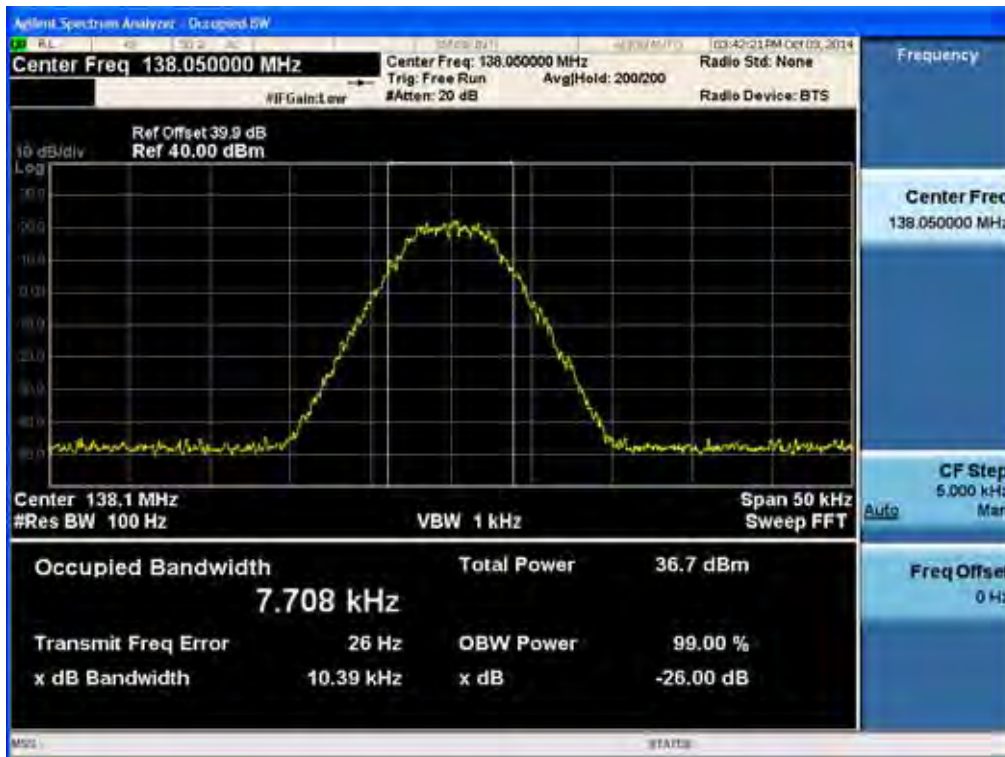

(8K30F1E, 8K30F1D, 8K30F7W _ 143.95 MHz)_Low

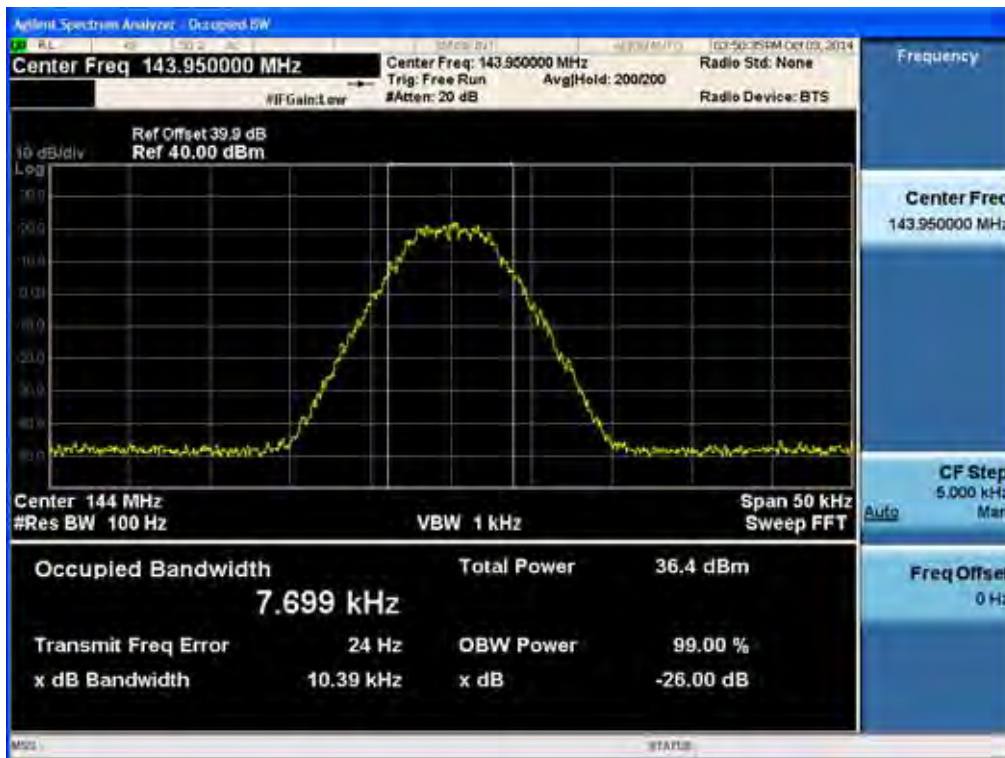

(8K30F1E, 8K30F1D, 8K30F7W _ 148.05 MHz)_Low

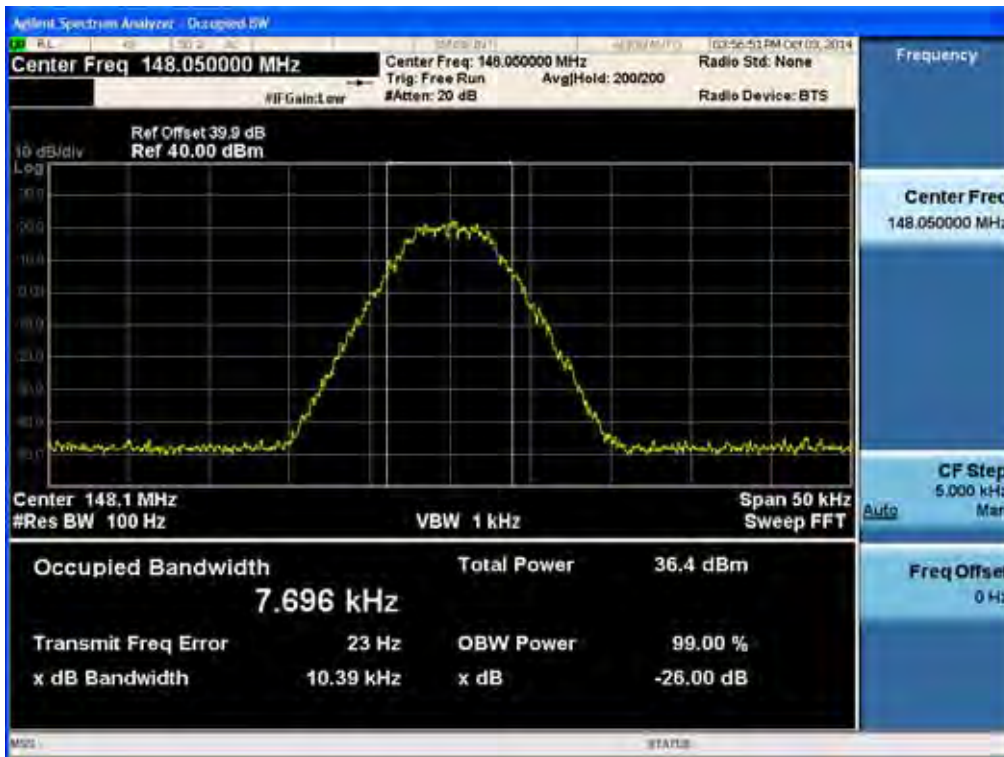

(8K30F1E, 8K30F1D, 8K30F7W _ 150.05 MHz)_Low

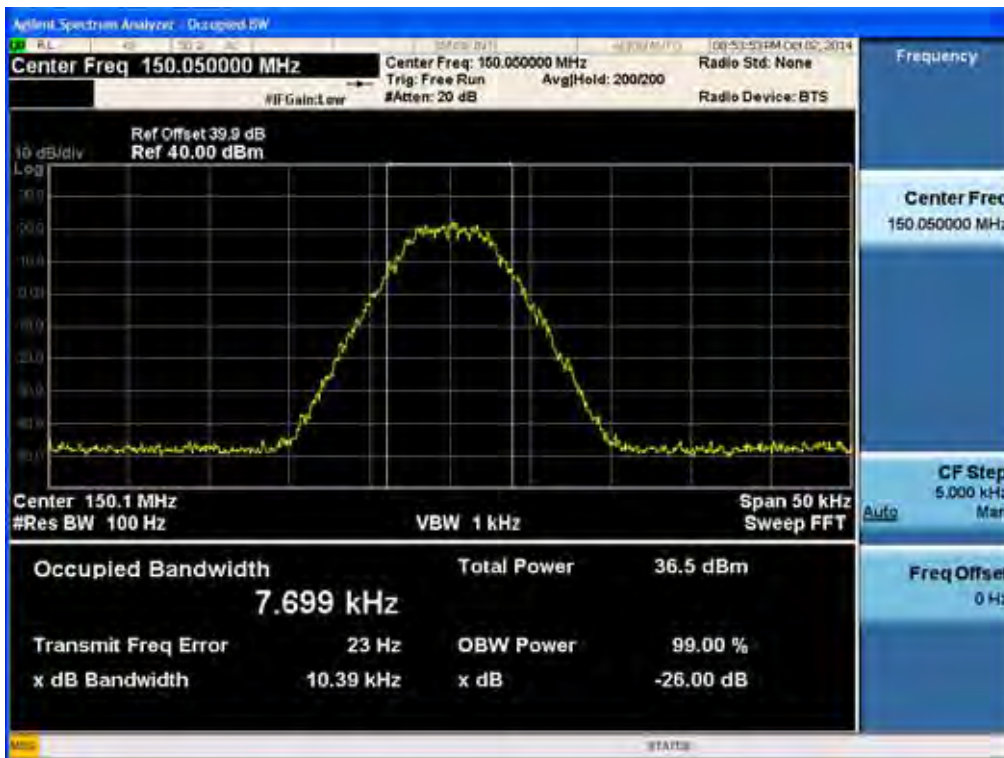

(8K30F1E, 8K30F1D, 8K30F7W _ 162.05 MHz)_Low

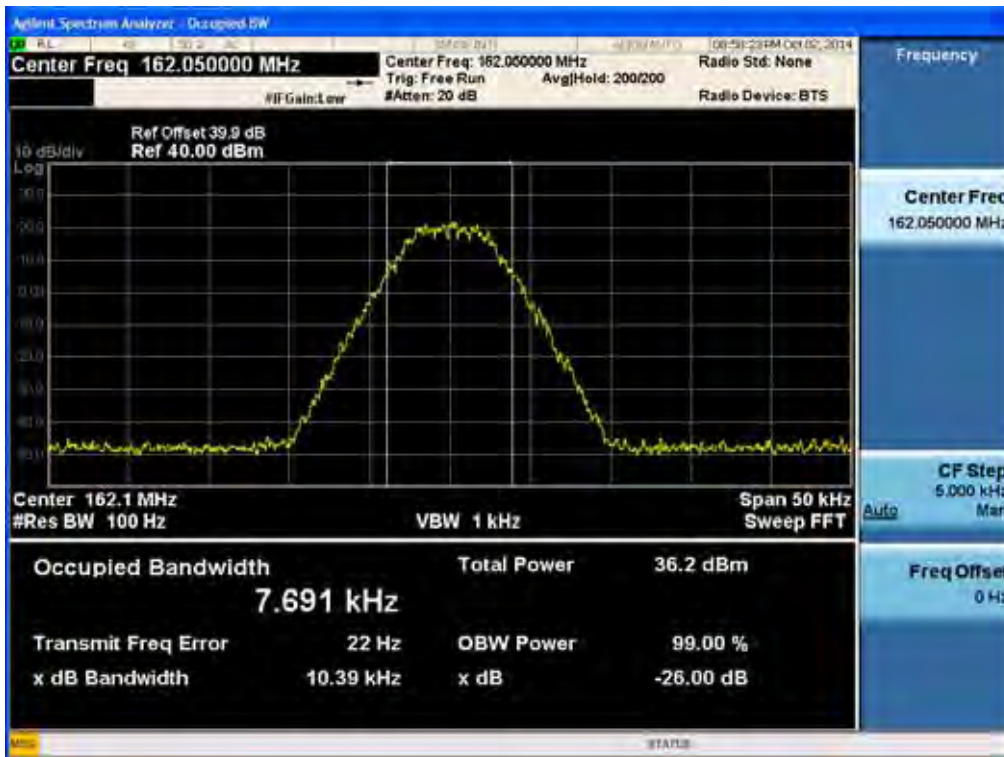

(8K30F1E, 8K30F1D, 8K30F7W _ 173.95 MHz)_Low

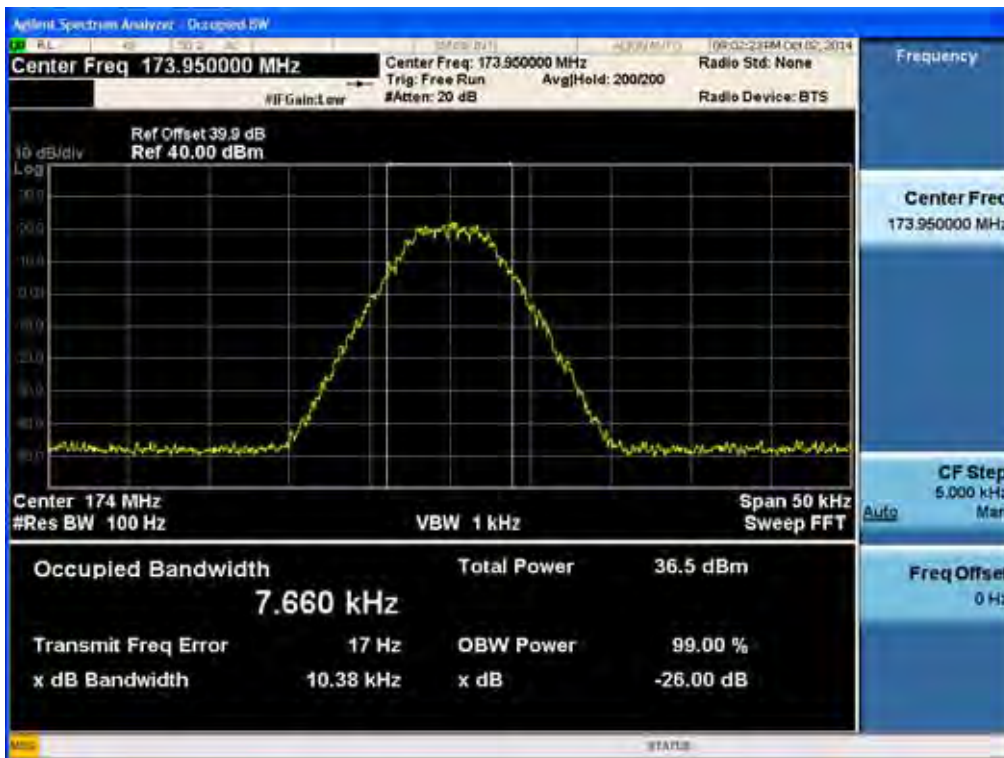

(4K00F1E, 4K00F1D, 4K00F7W _ 138.05 MHz)_High

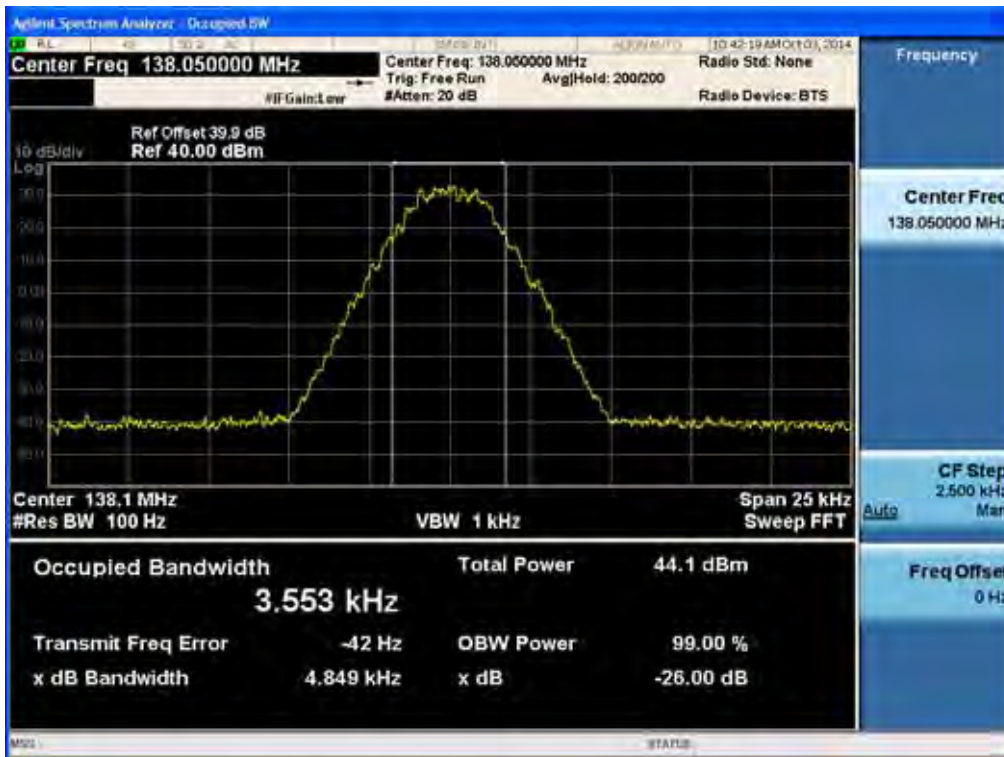

(4K00F1E, 4K00F1D, 4K00F7W _ 143.95 MHz)_High

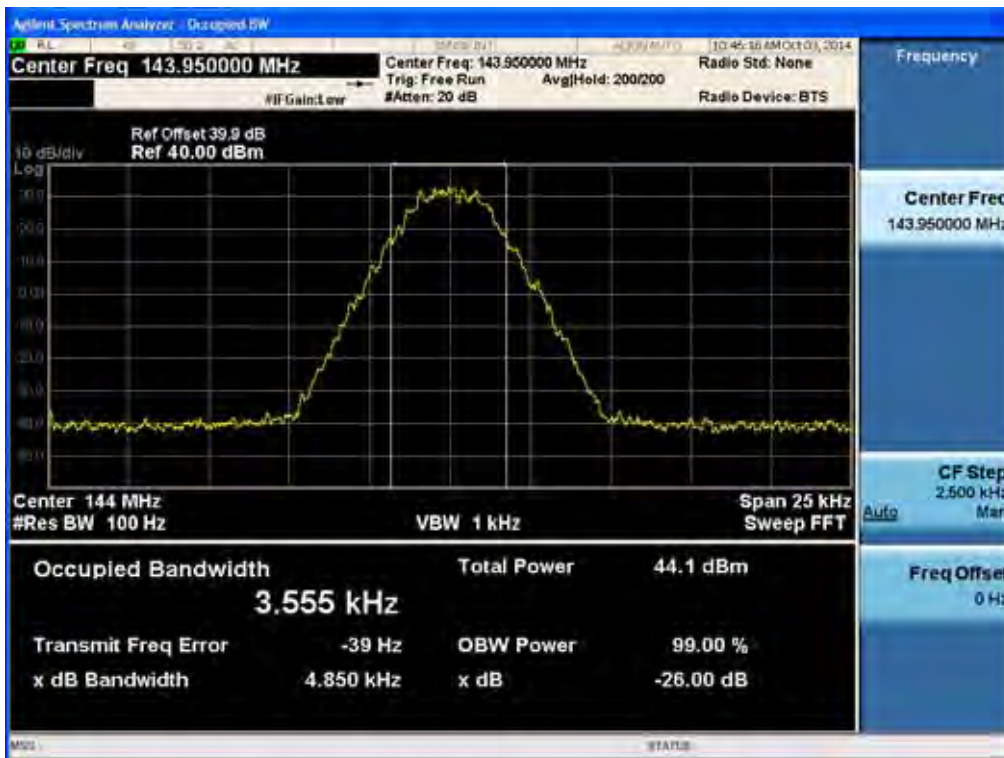

(4K00F1E, 4K00F1D, 4K00F7W _ 148.05 MHz)_High

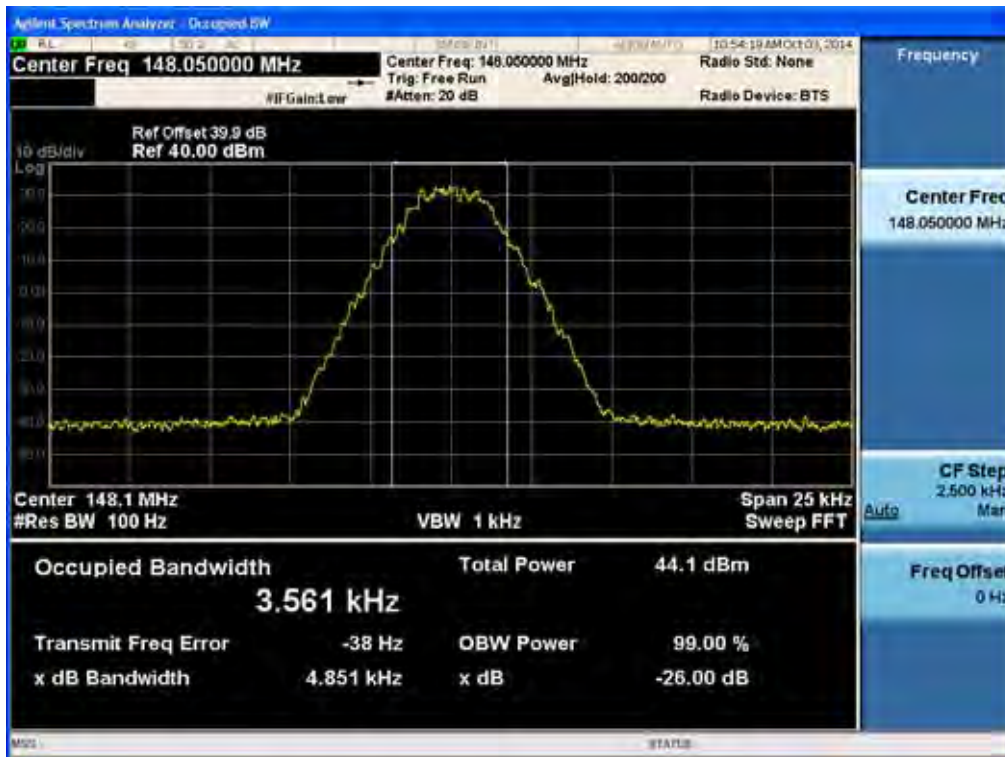

(4K00F1E, 4K00F1D, 4K00F7W _ 150.05 MHz)_High

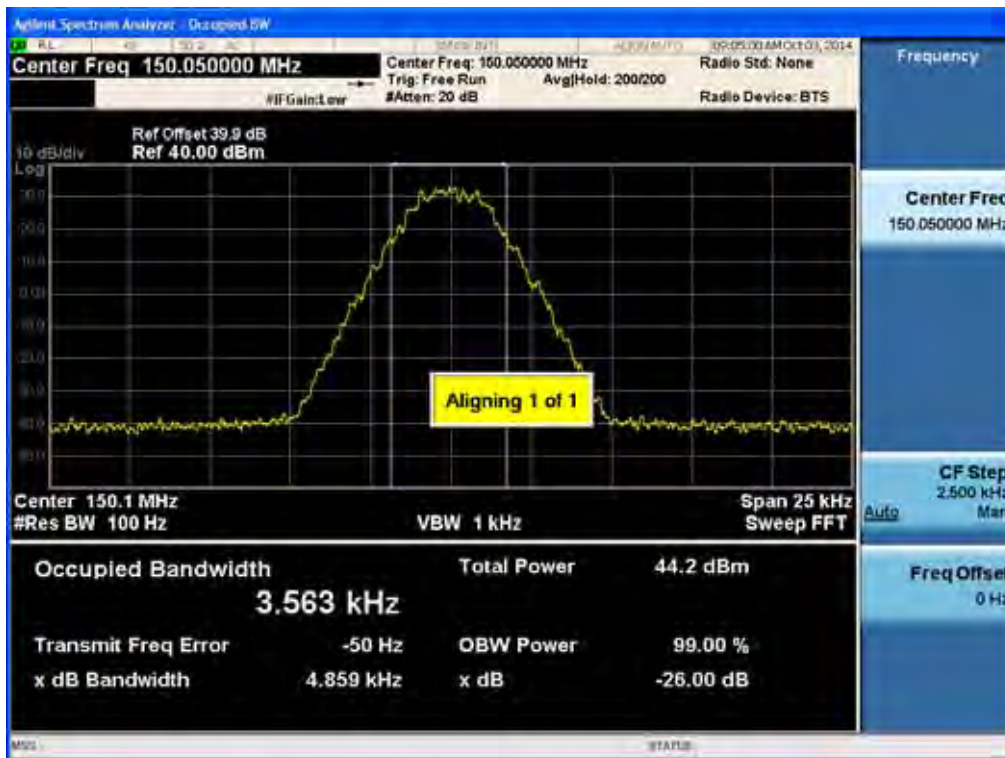

(4K00F1E, 4K00F1D, 4K00F7W _ 162.05 MHz)_High

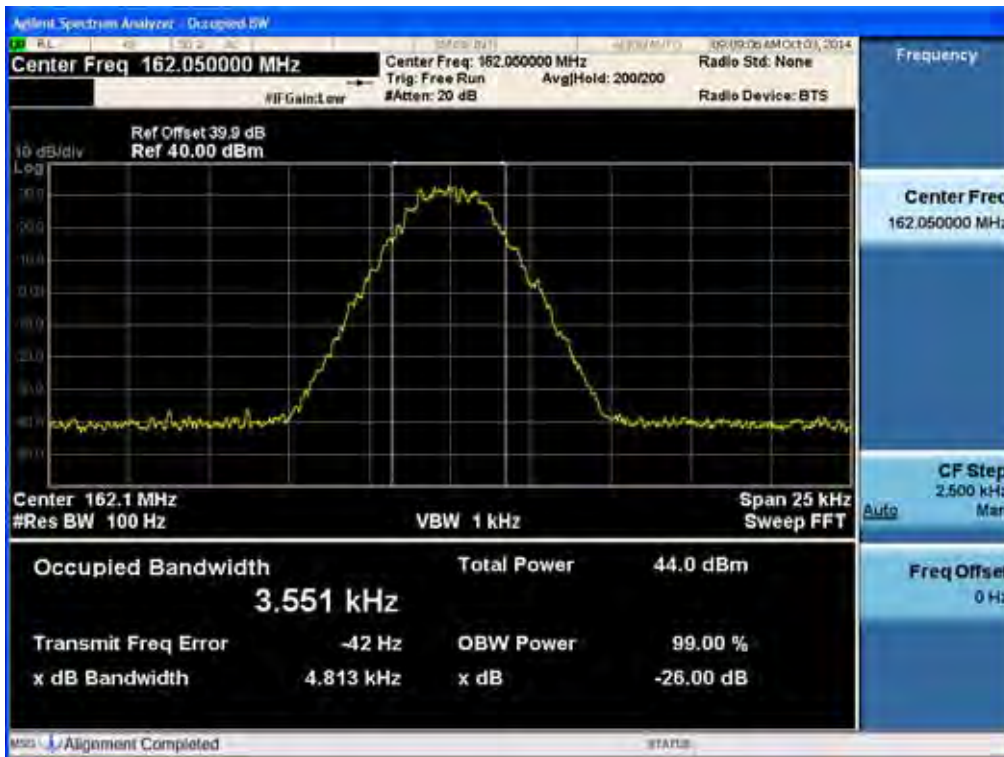

(4K00F1E, 4K00F1D, 4K00F7W _ 173.95 MHz)_High

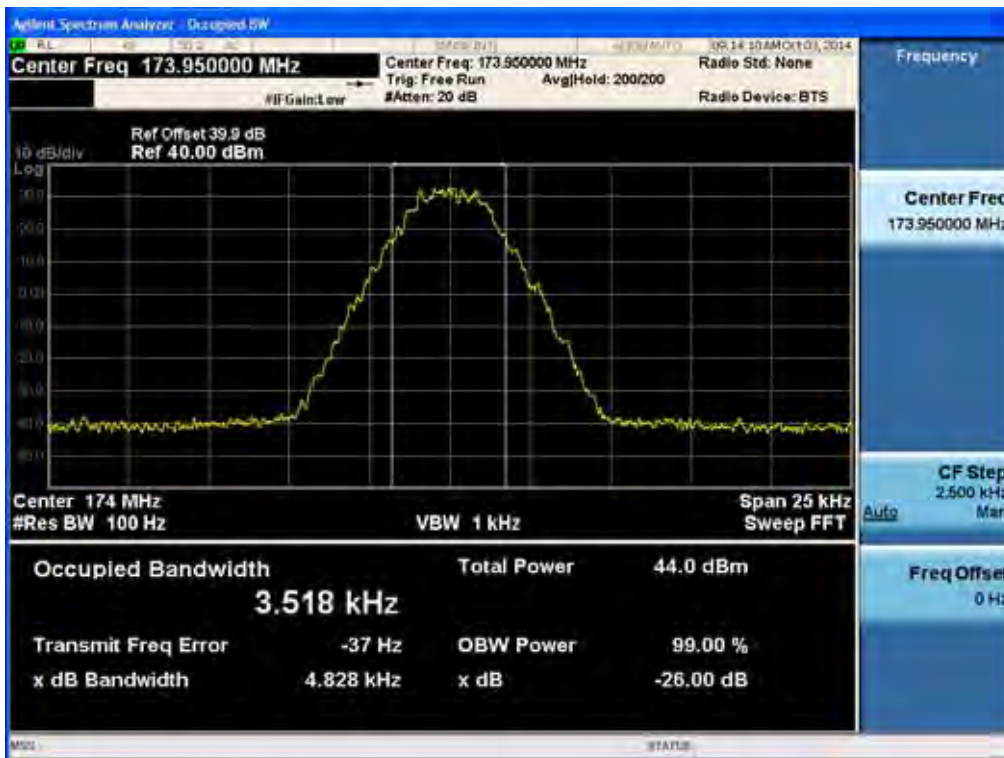

(4K00F1E, 4K00F1D, 4K00F7W _ 138.05 MHz)_Low

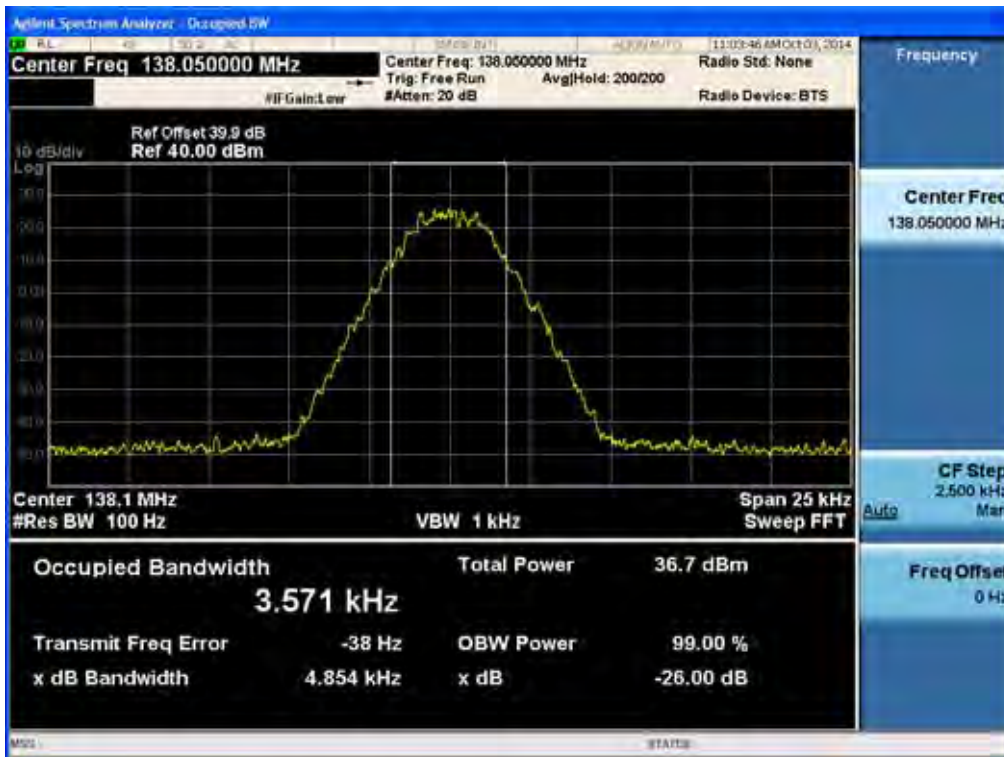

(4K00F1E, 4K00F1D, 4K00F7W _ 143.95 MHz)_Low

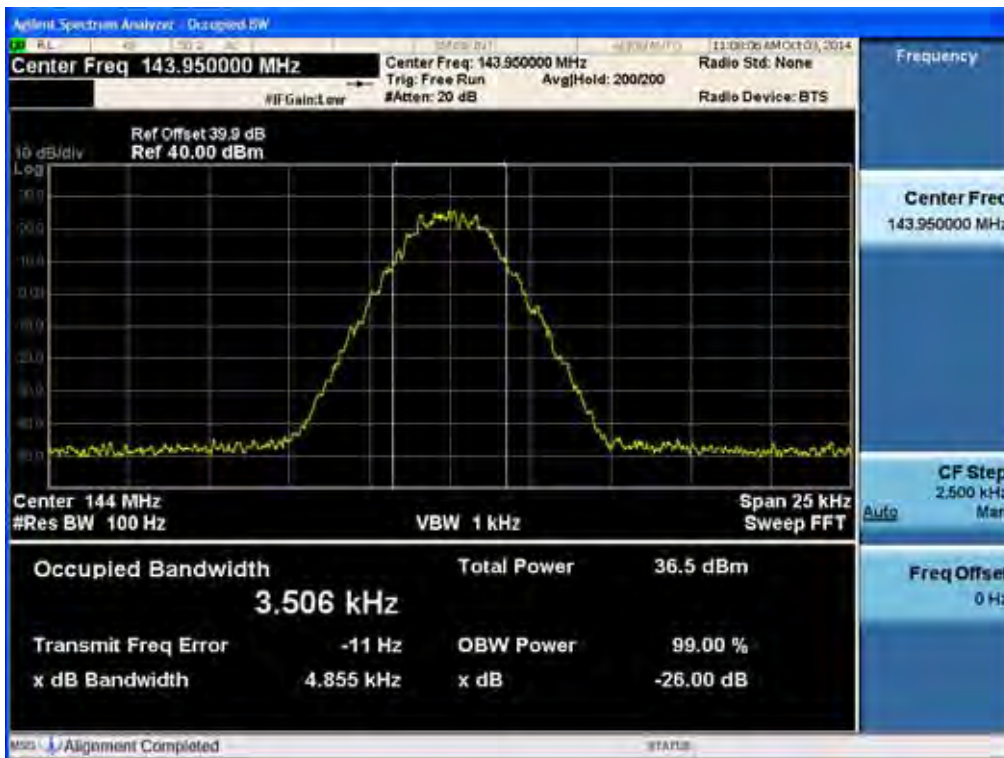

(4K00F1E, 4K00F1D, 4K00F7W _ 148.05 MHz)_Low

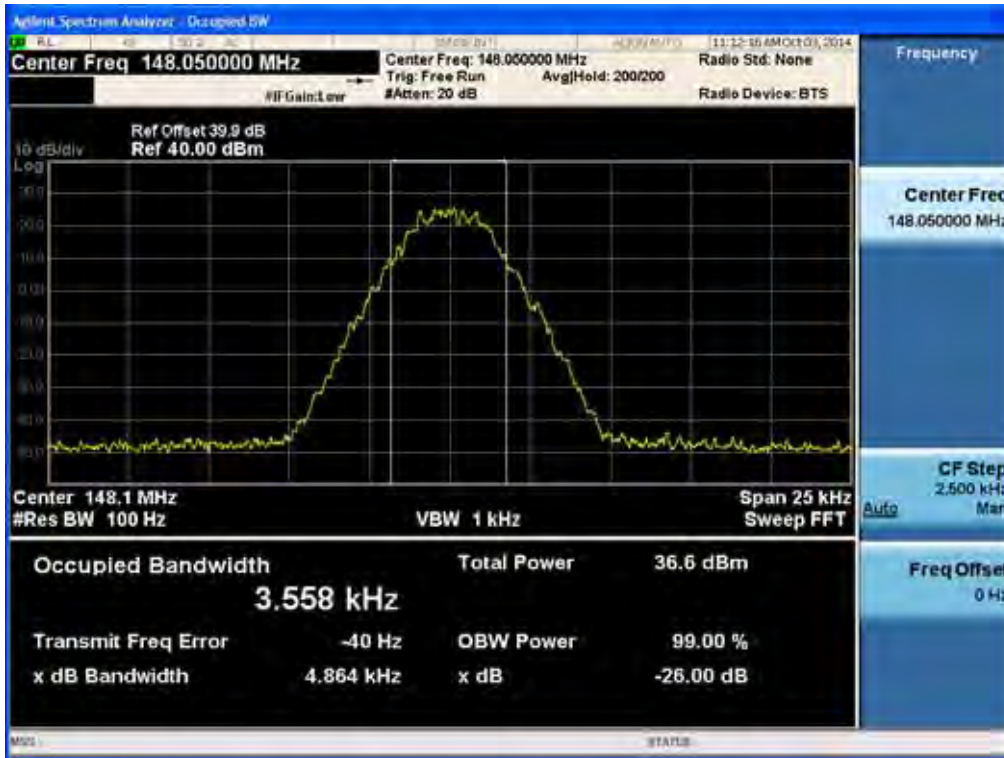

(4K00F1E, 4K00F1D, 4K00F7W _ 150.05 MHz)_Low

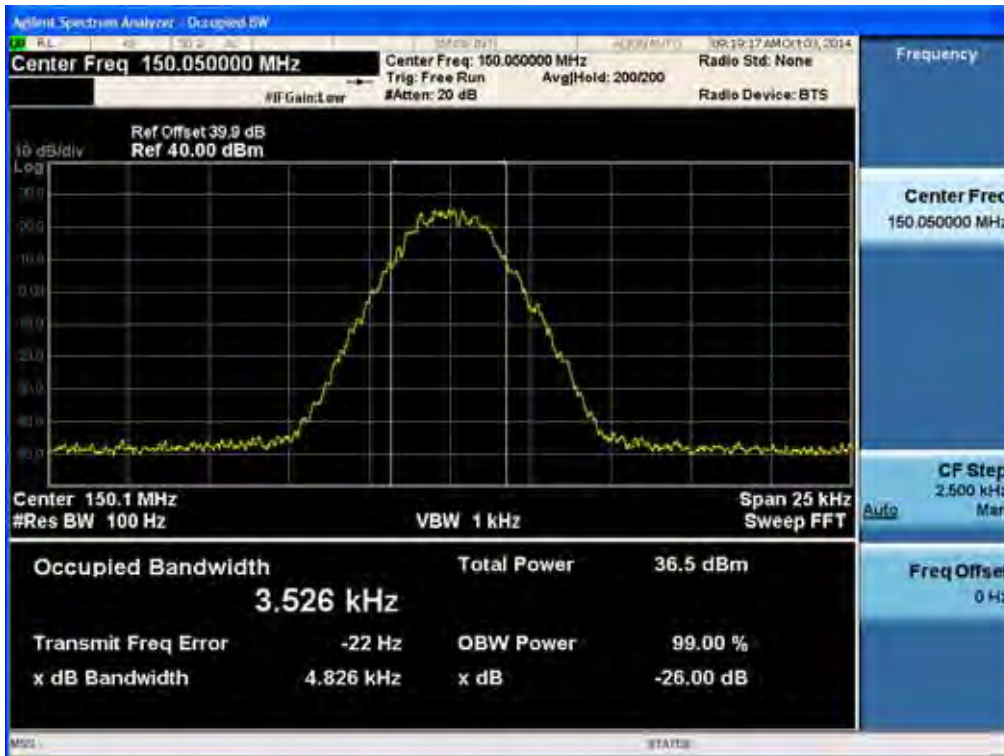

(4K00F1E, 4K00F1D, 4K00F7W _ 162.05 MHz)_Low

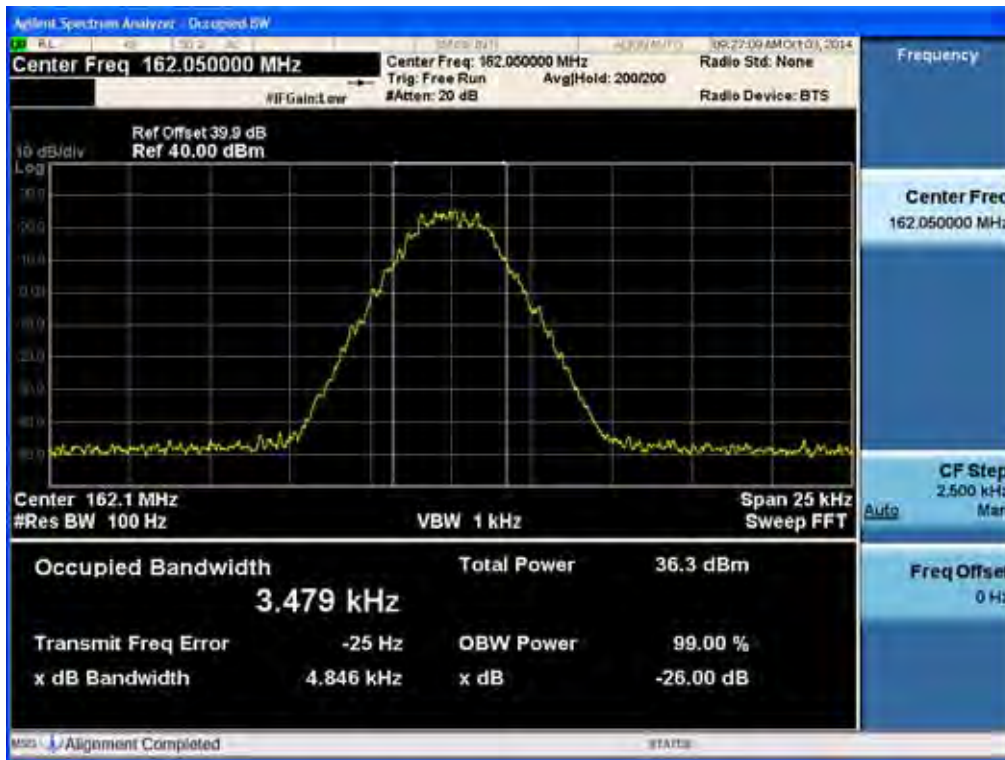

(4K00F1E, 4K00F1D, 4K00F7W _ 173.95 MHz)_Low

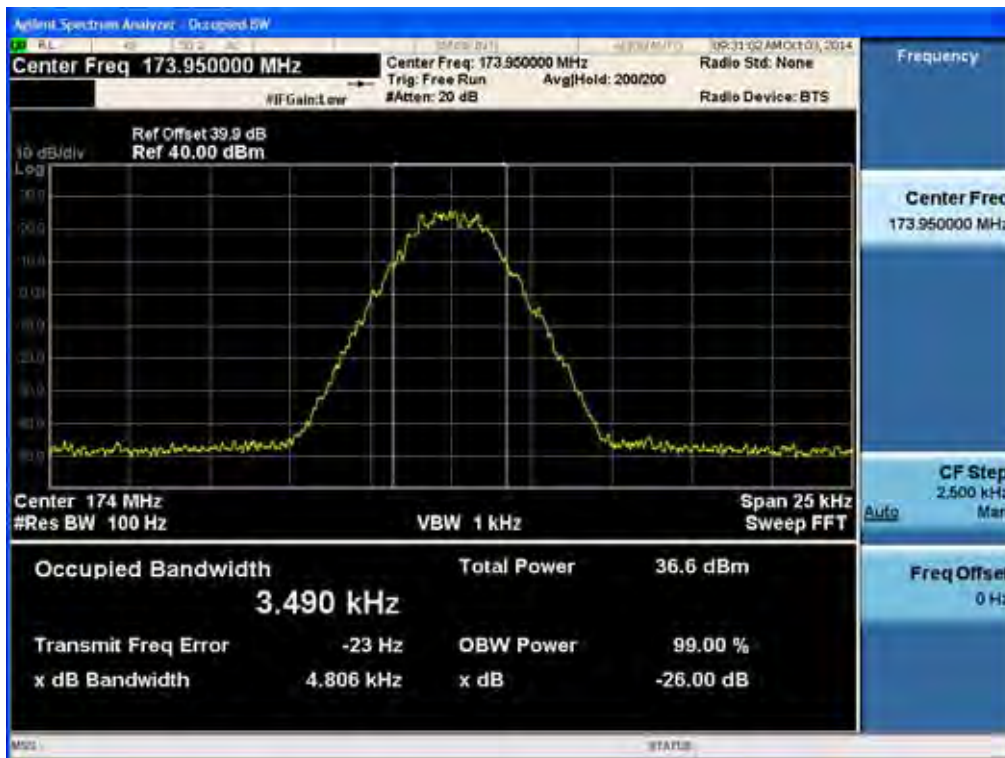

(4K00F2D _ 138.05 MHz)_Low

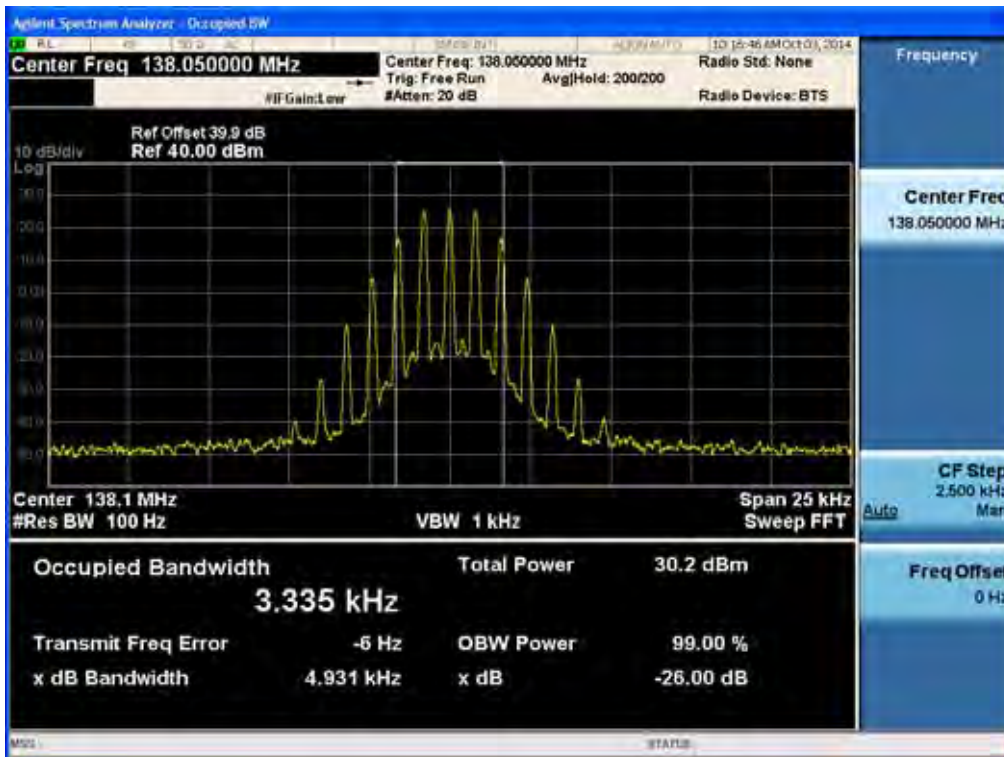

(4K00F2D _ 143.95 MHz)_Low

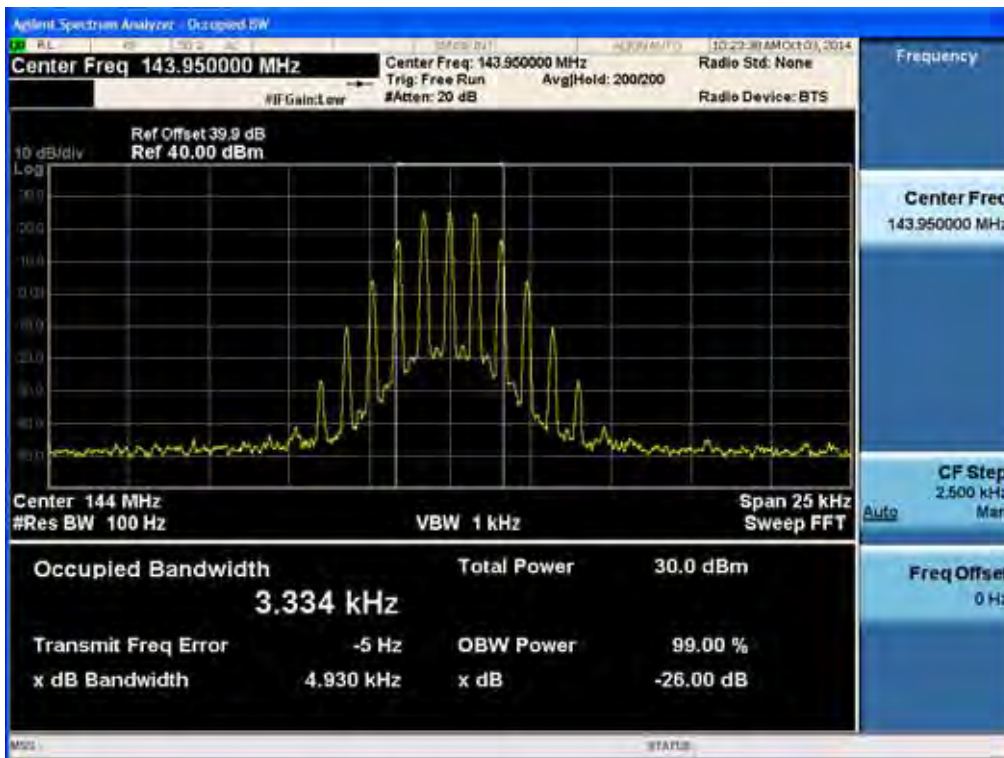

(4K00F2D _ 148.05 MHz)_Low

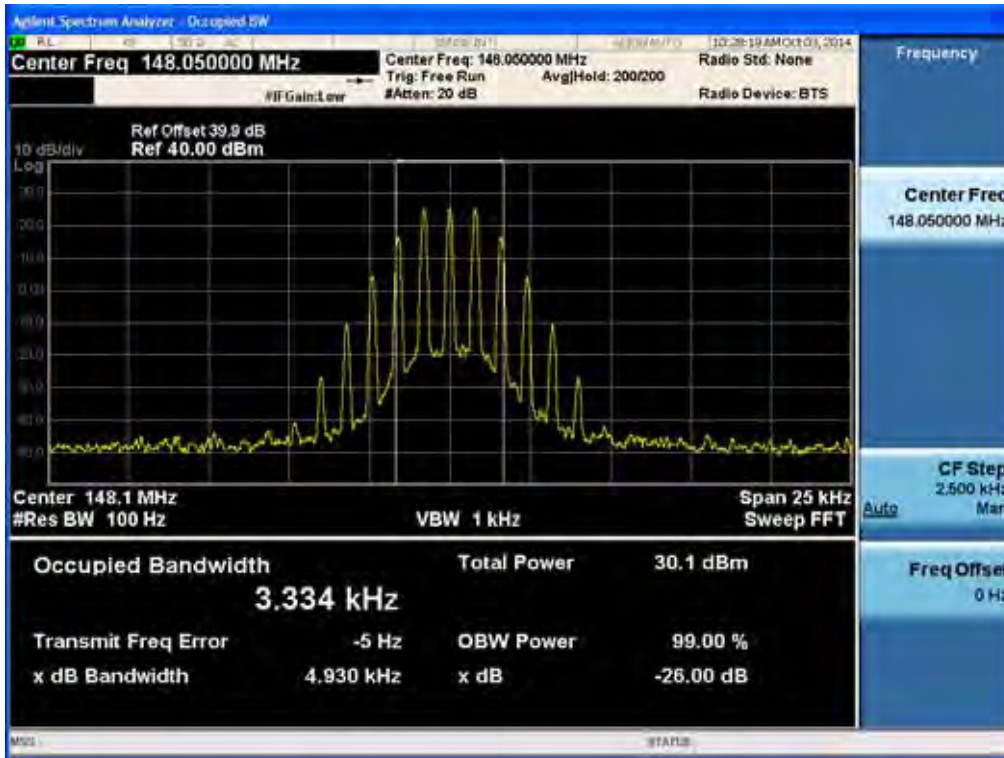

(4K00F2D _ 150.05 MHz)_Low

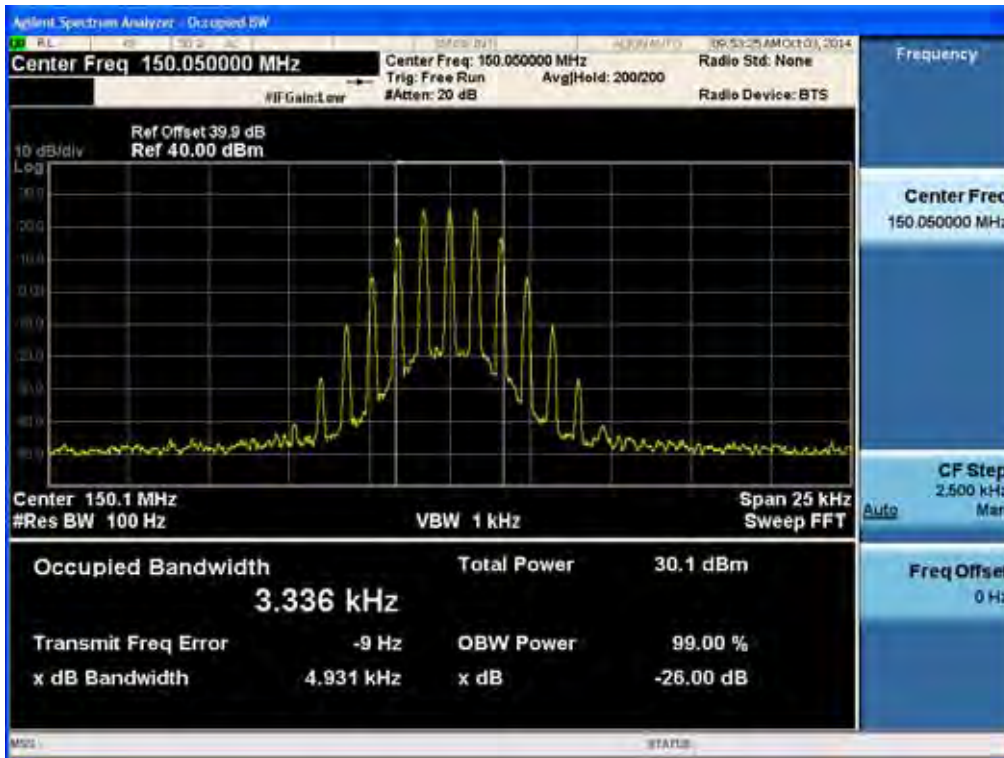

(4K00F2D _ 162.05 MHz)_Low

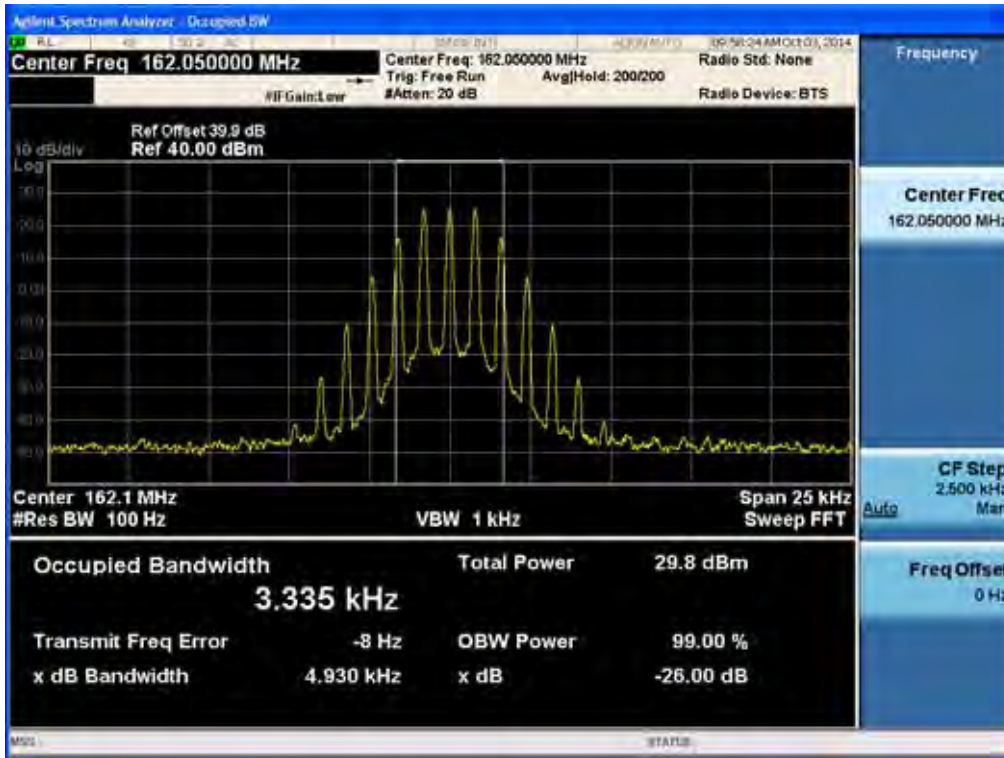

(4K00F2D _ 173.95 MHz)_Low

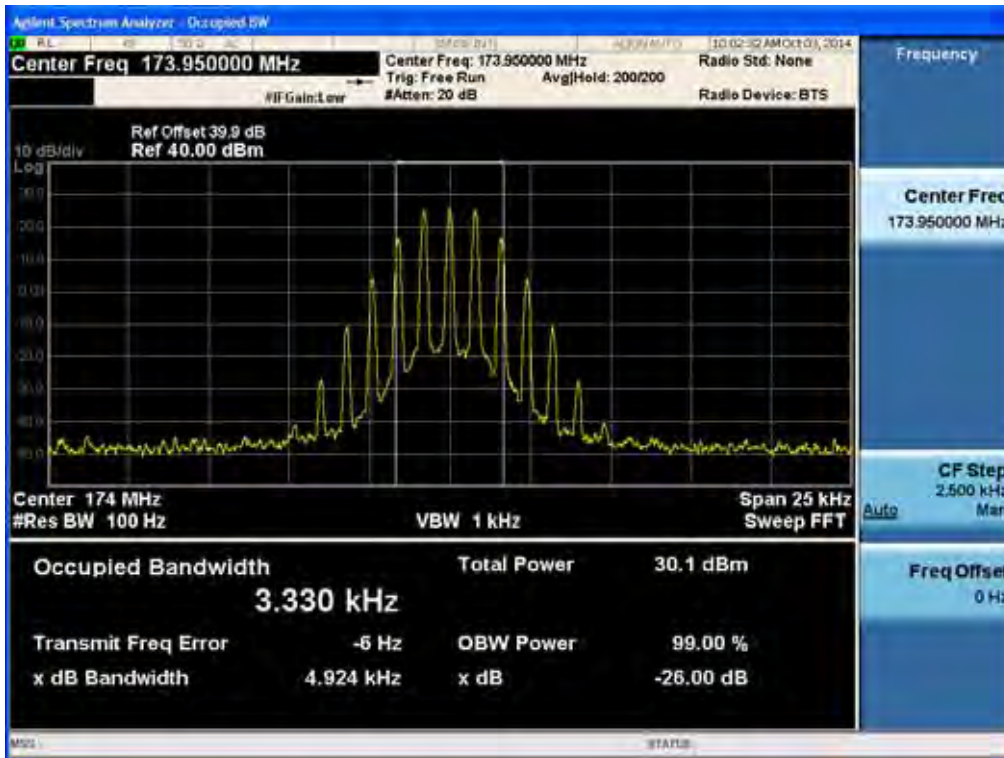

7.4 Modulation Limiting

Definition

Modulation limiting is the transmitter circuit's ability to limit the transmitter from producing deviations in excess of a rated system deviation.

TEST CONFIGURATION

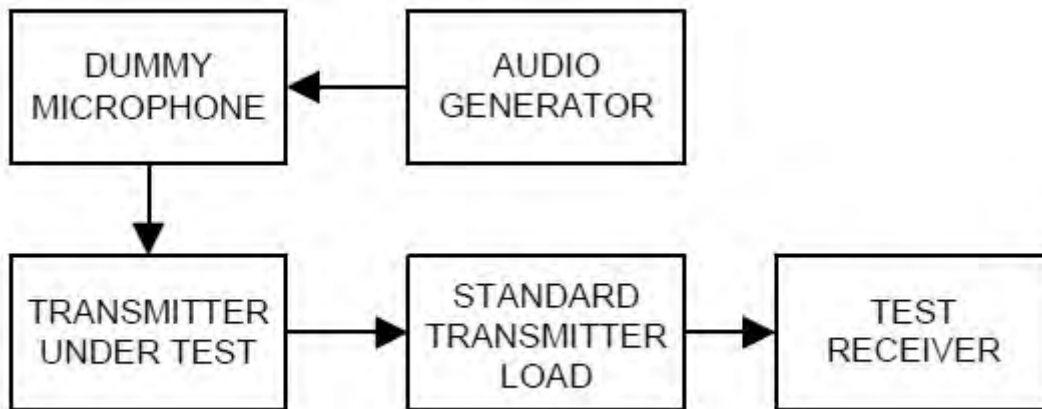

TEST PROCEDURE

According to 2.2.3 in TIA-603-D Standard.

- a) Connect the equipment as illustrated.
- b) Adjust the transmitter per the manufacturer's procedure for full rated system deviation.
- c) Set the test receiver to measure peak positive deviation.
Set the audio bandwidth for ≤ 0.25 Hz to $\geq 15,000$ Hz.
Turn the de-emphasis function off.
- d) Apply a 1000 Hz modulating signal to the transmitter from the audio frequency generator, and adjust the level obtain 60% of full rated system deviation.
- e) Increase the level form the audio frequency generator by 20 dB in one step(rise time between the 10% and 90% points shall be 0.1 second maximum).
- f) Measure both the instantaneous and steady-state deviation at and after the time of increasing the audio input level.
- g) With the level from the audio frequency generator held constant at the level obtained in step e), Slowly vary the audio frequency from 300 Hz to 3000 Hz and observe the steady-state deviation. Record the maximum deviation.
- h) Set the test receiver to measure peak negative deviation and repeat steps d) through g).
- i) The values recorded in steps g) and h) are the modulation limiting.

TEST RESULTS

11K0F3E For FCC

Positive Peaks

11K0F3E_150.05 MHz_HIGH POWER

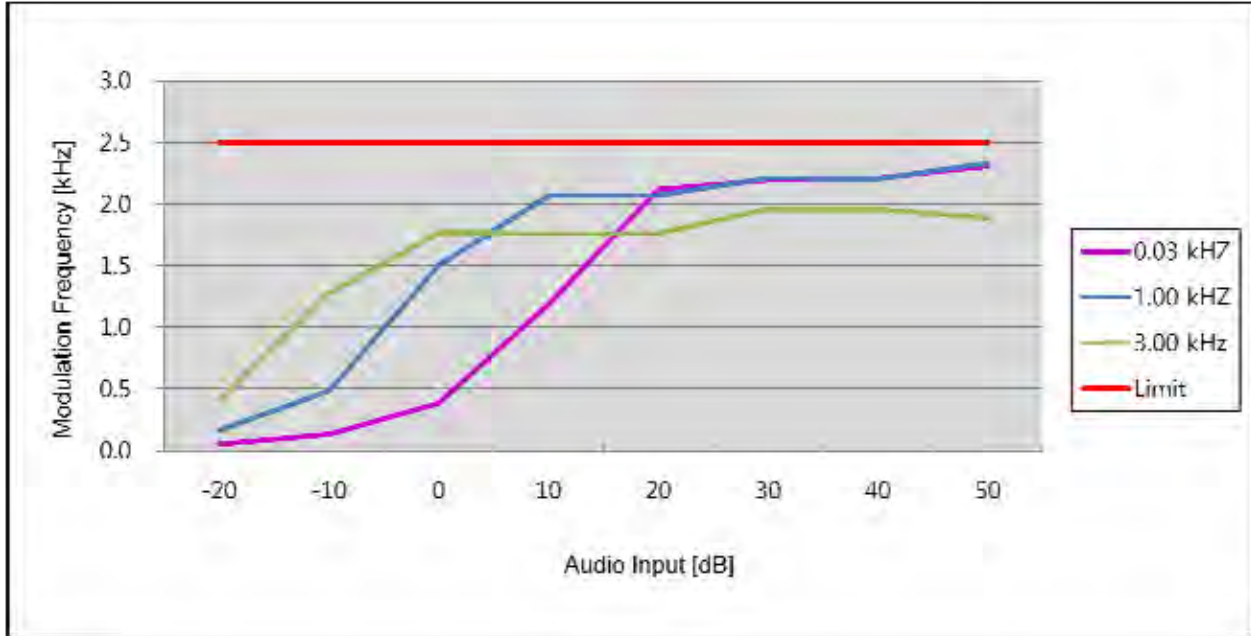

11K0F3E_162.05 MHz_HIGH POWER

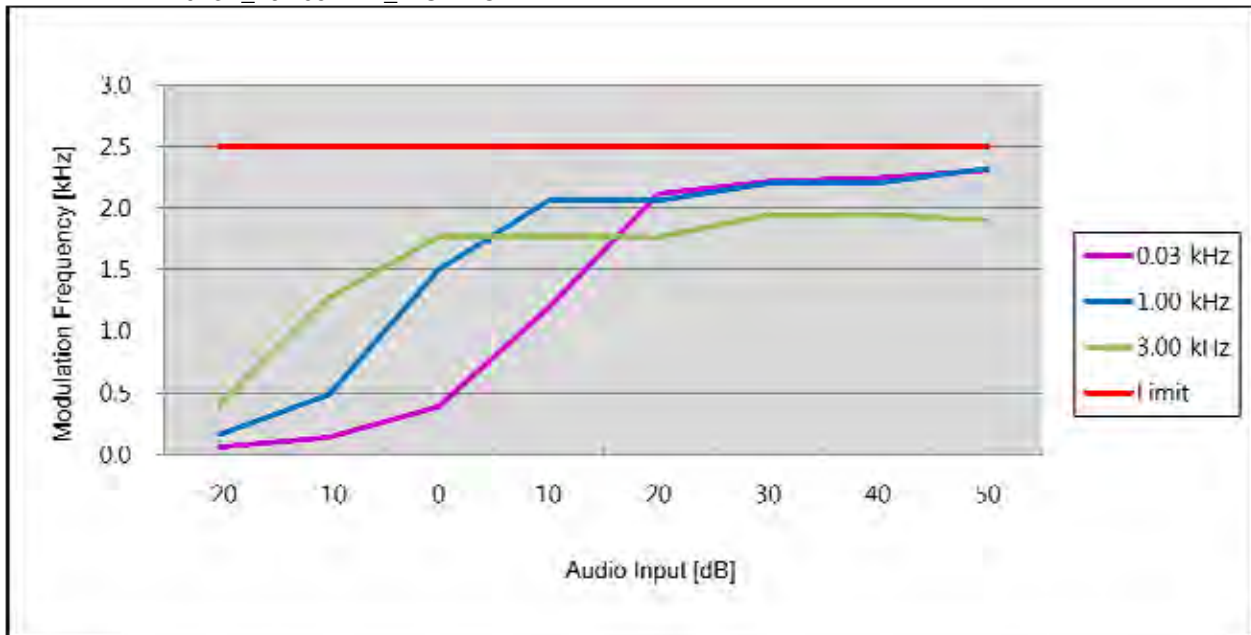

11K0F3E_173.95 MHz_HIGH POWER

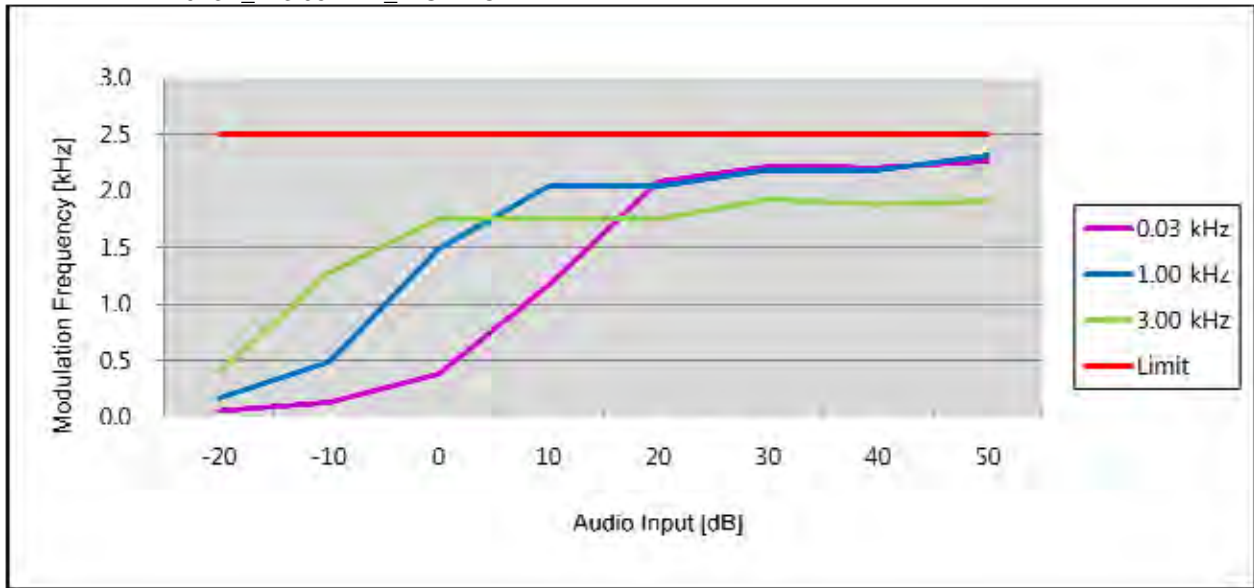

11K0F3E_150.05 MHz_LOW POWER

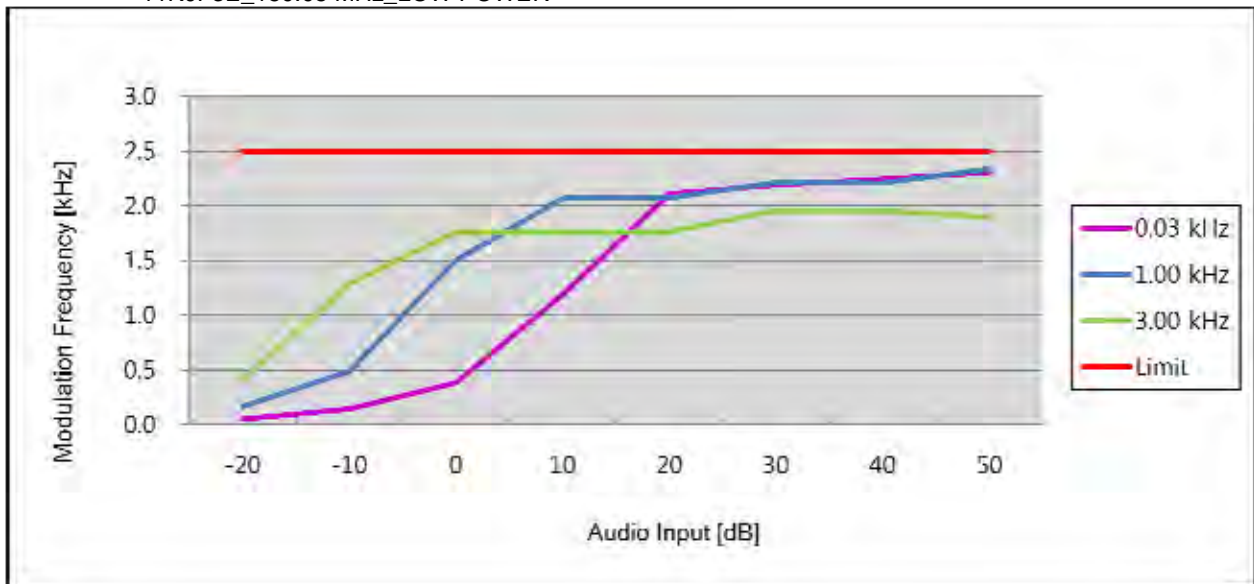

11K0F3E_162.05 MHz_LOW POWER

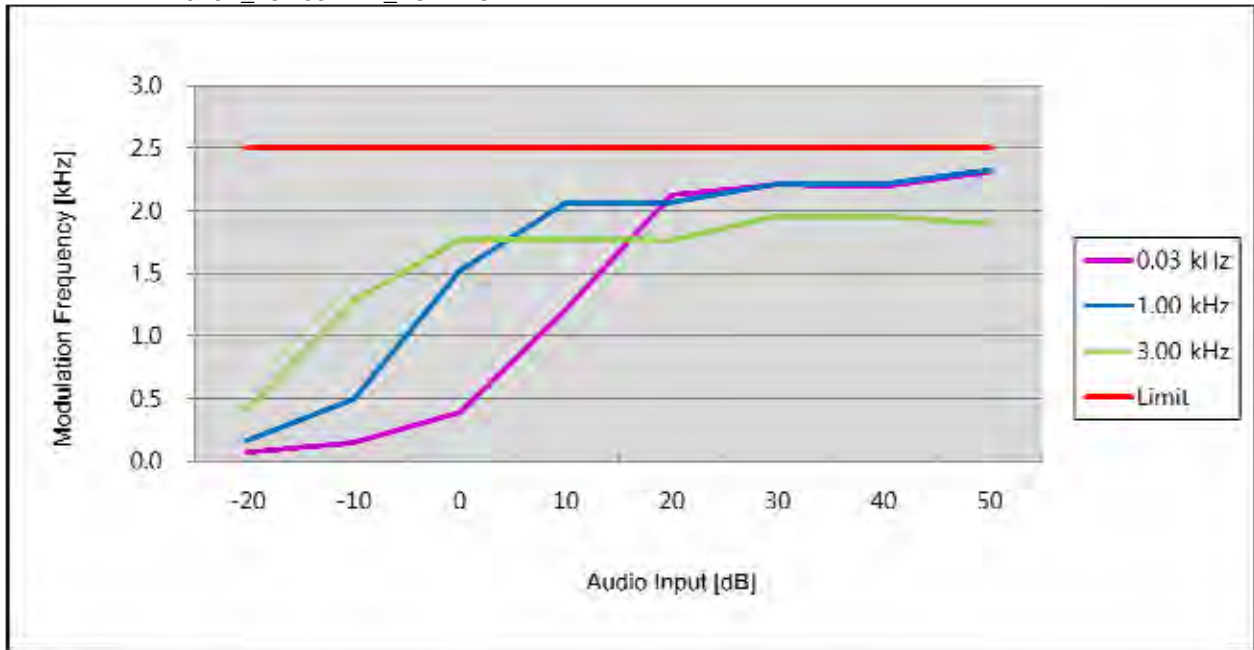

11K0F3E_173.95 MHz_LOW POWER

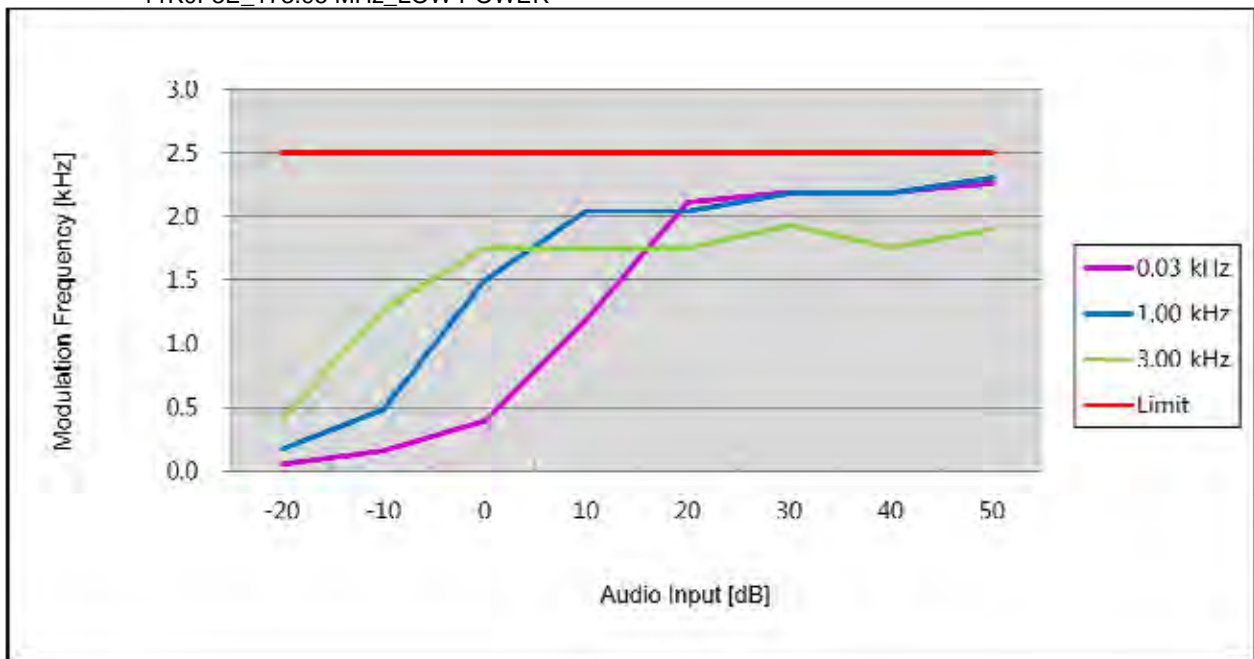

Negative Peaks

11K0F3E_150.05 MHz_HIGH POWER

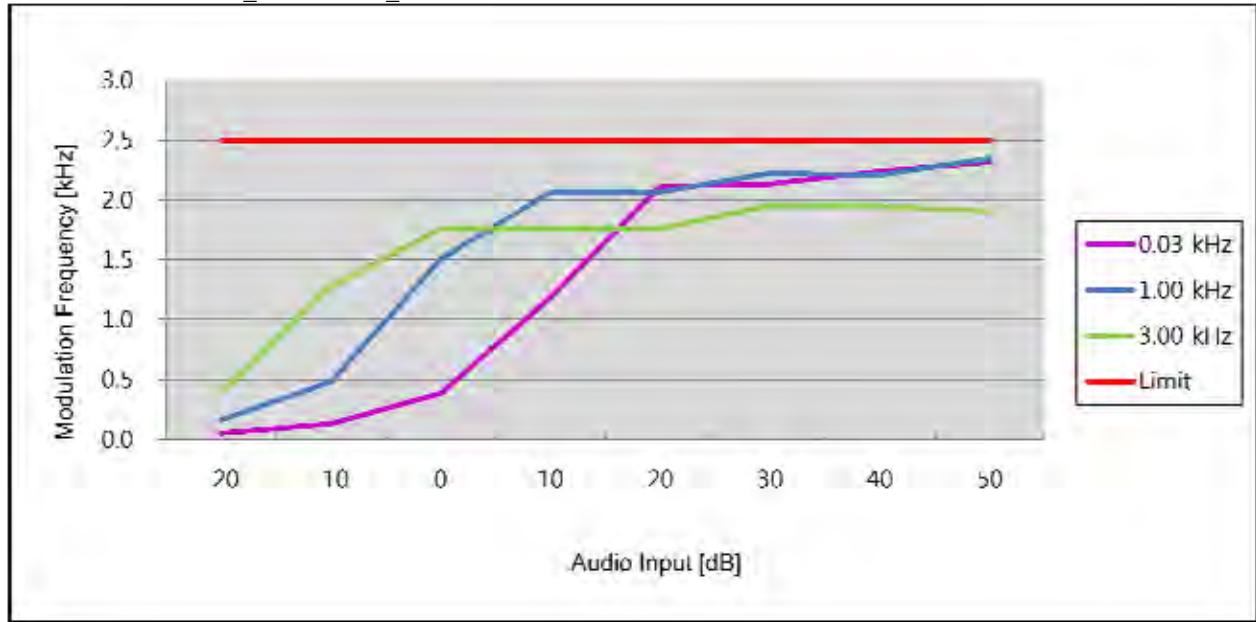

11K0F3E_162.05 MHz_HIGH POWER

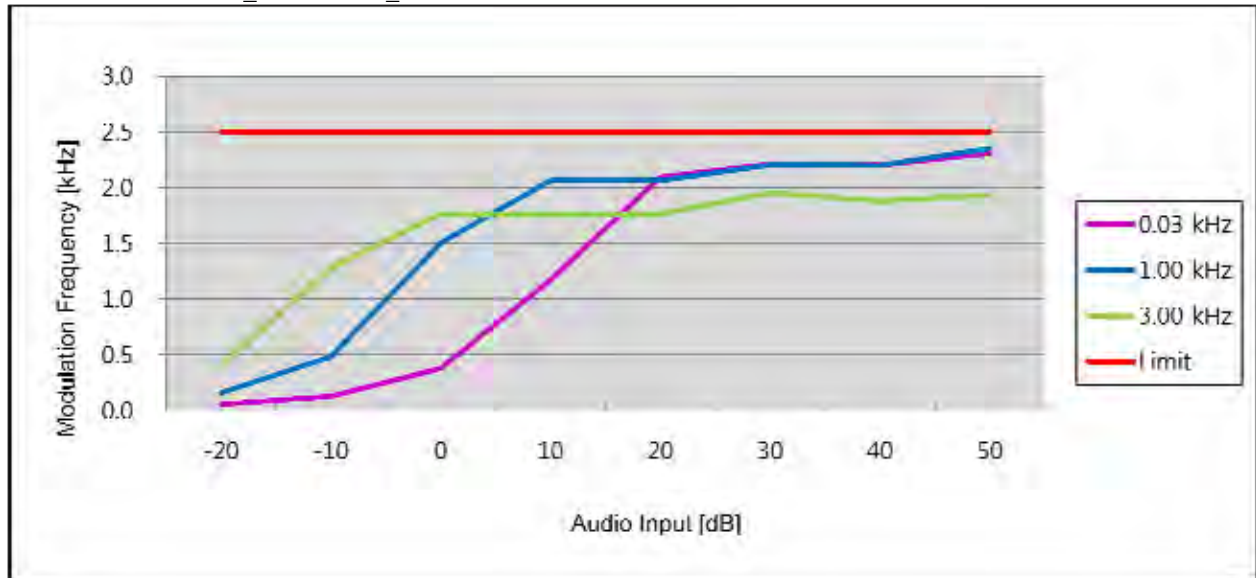

11K0F3E_173.95 MHz_HIGH POWER

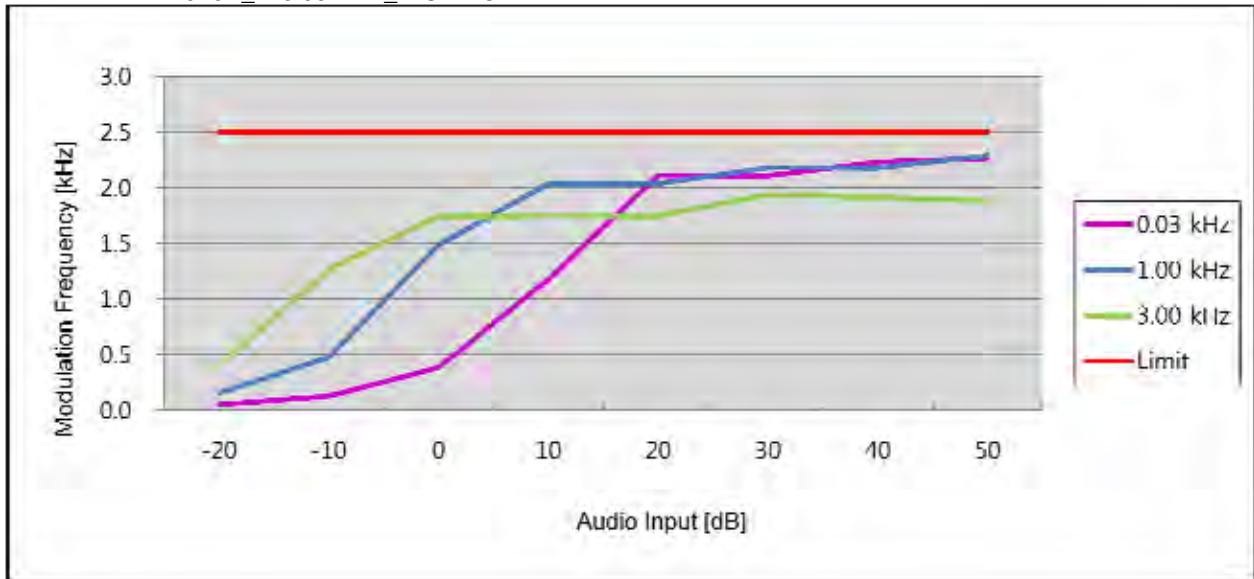

11K0F3E_150.05 MHz_LOW POWER

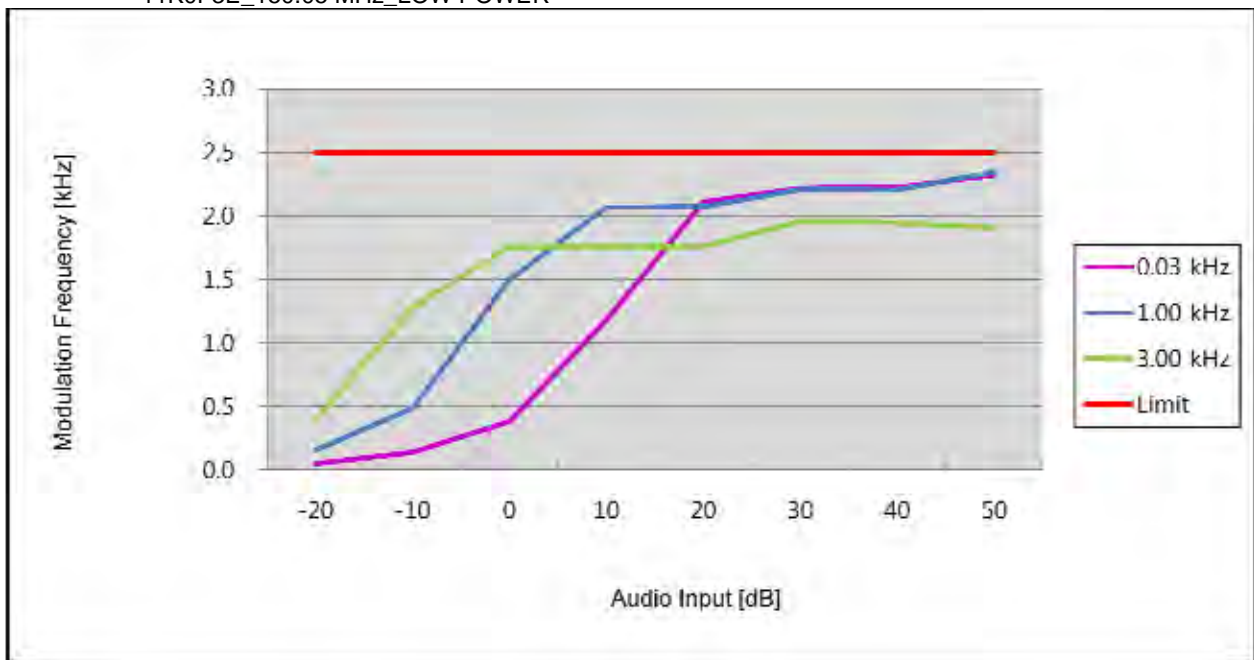

11K0F3E_162.05 MHz_LOW POWER

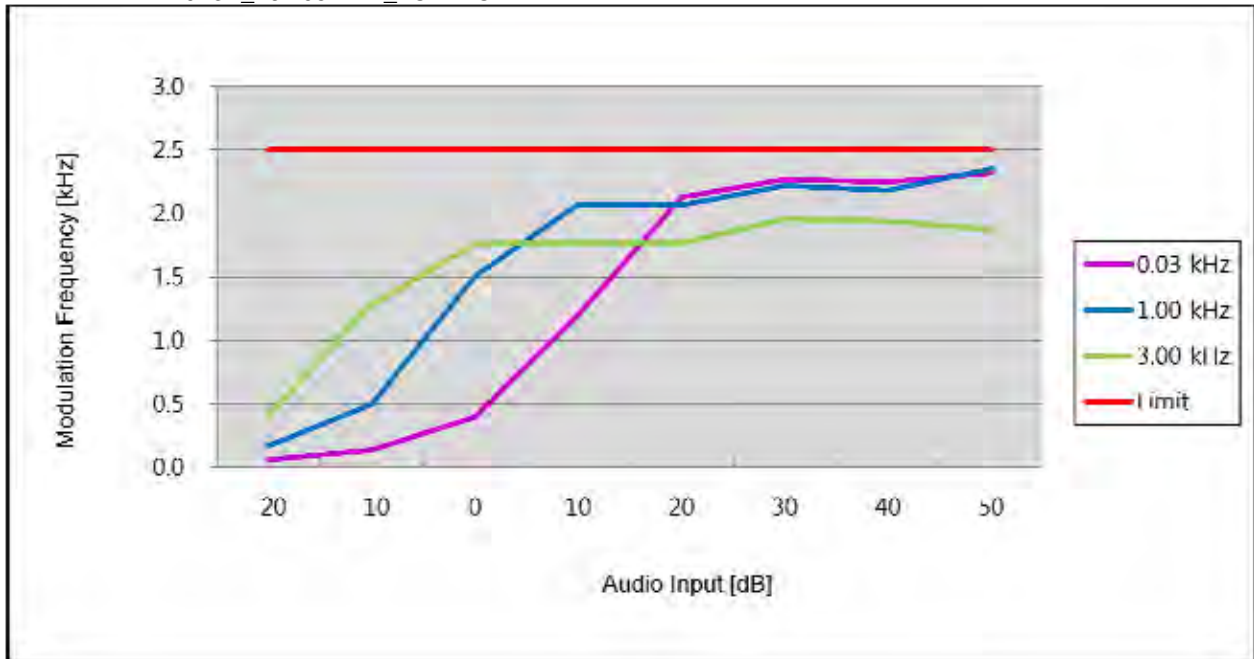

11K0F3E_173.95 MHz_LOW POWER

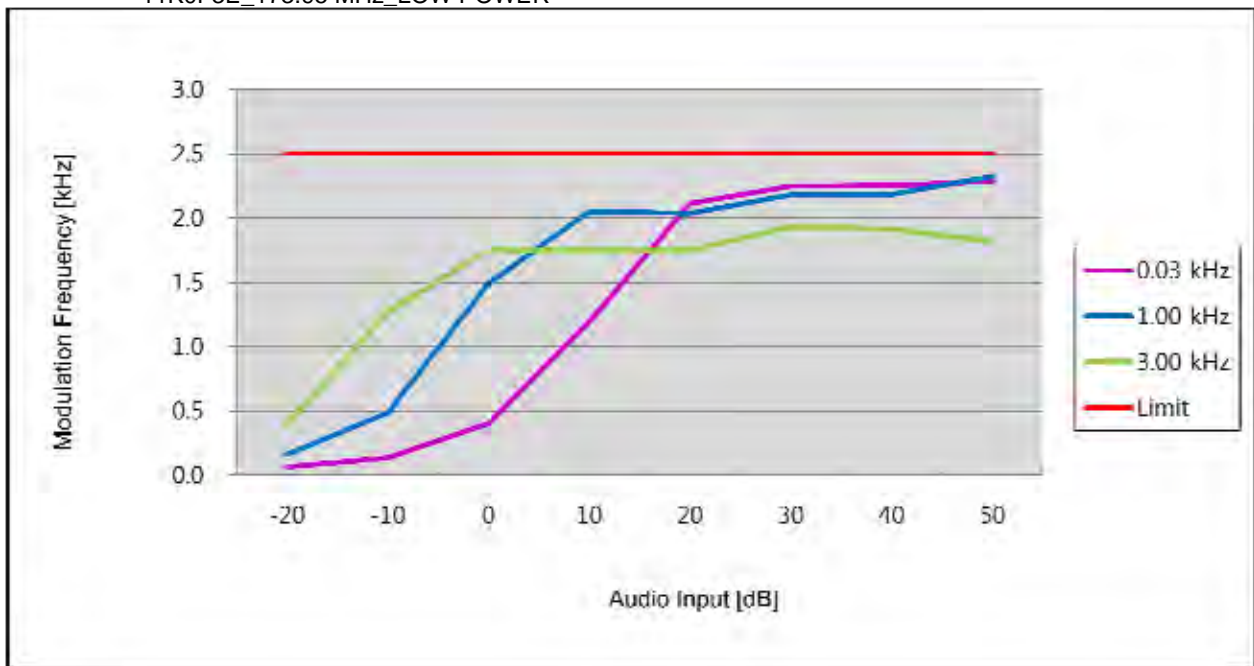

TEST RESULTS

16K0F3E For IC

Positive Peaks

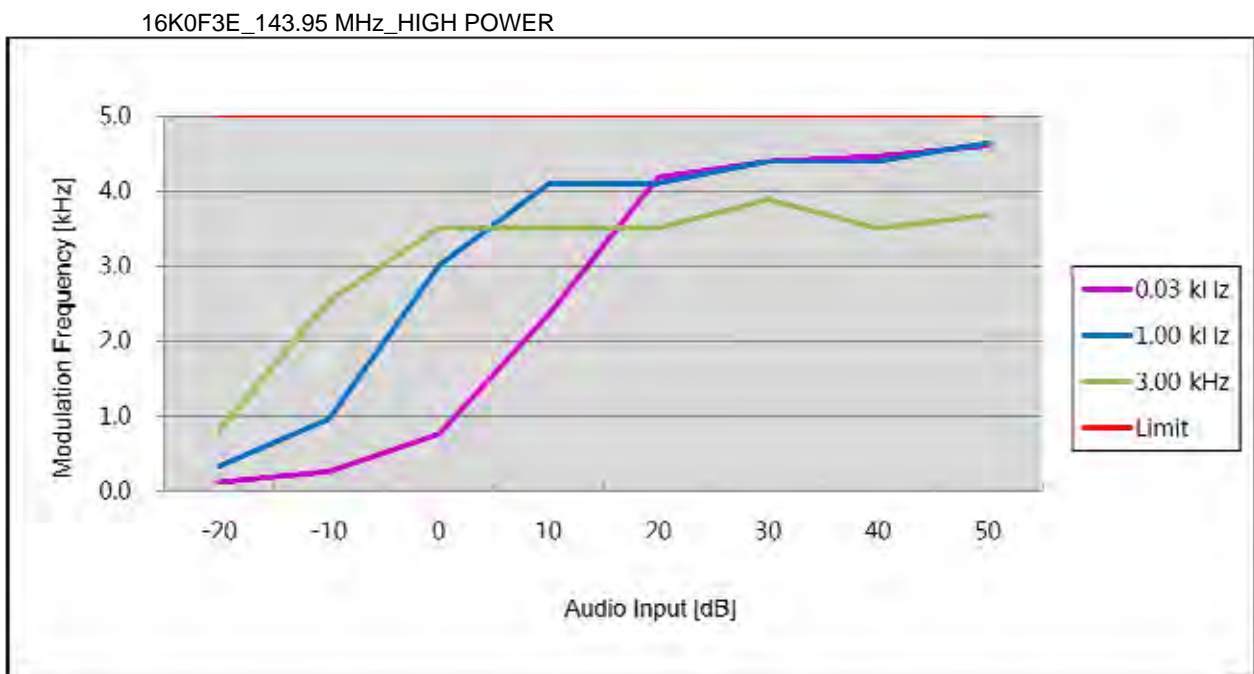
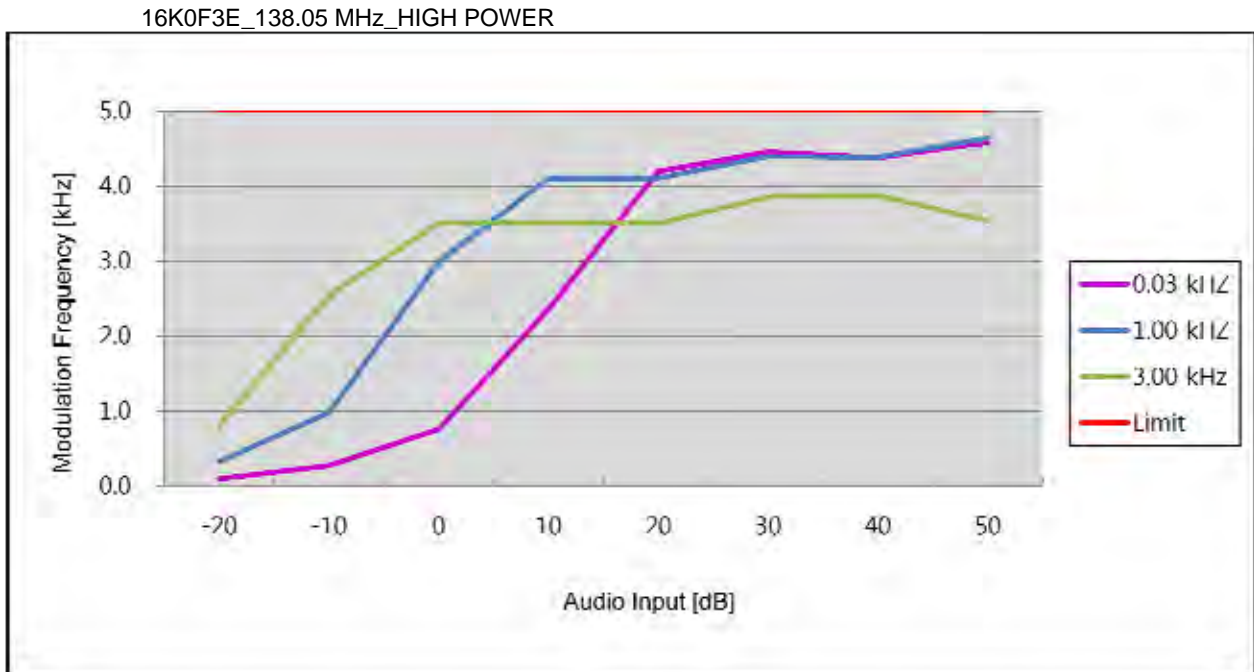

16K0F3E_148.05 MHz_HIGH POWER

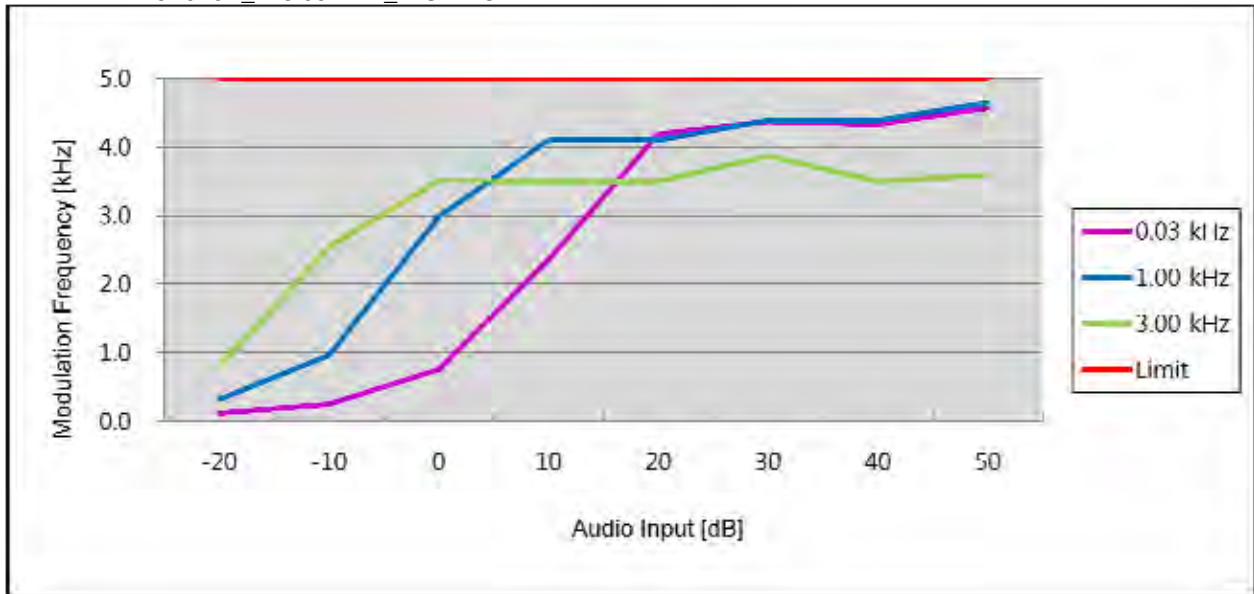

16K0F3E_138.05 MHz_LOW POWER

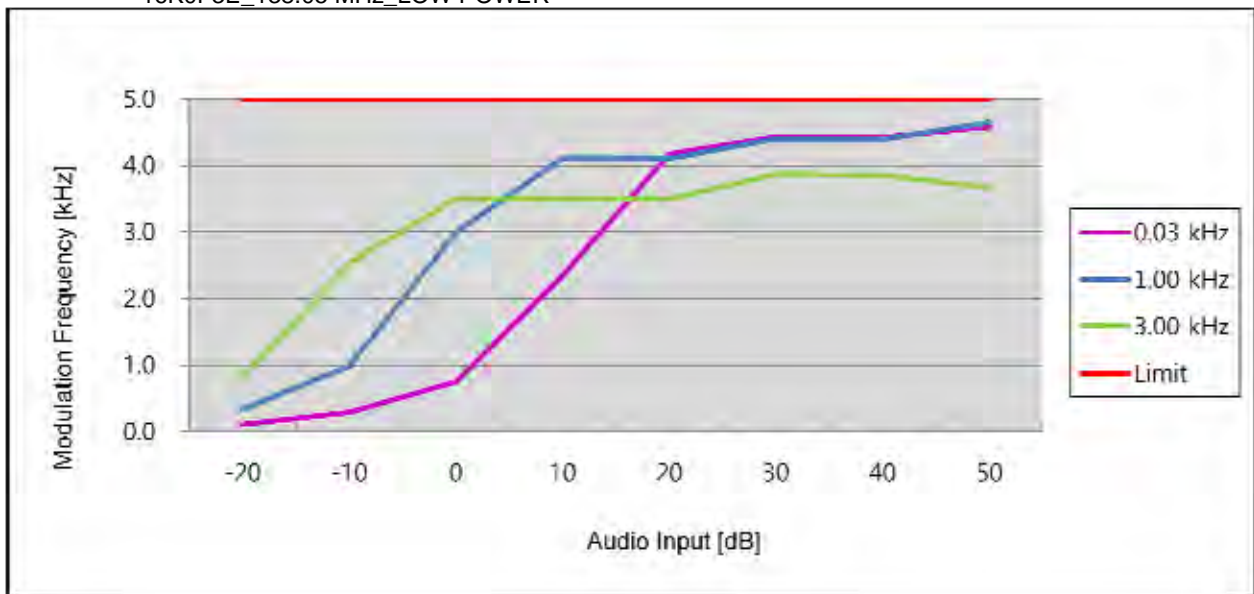

16K0F3E_143.95 MHz_LOW POWER

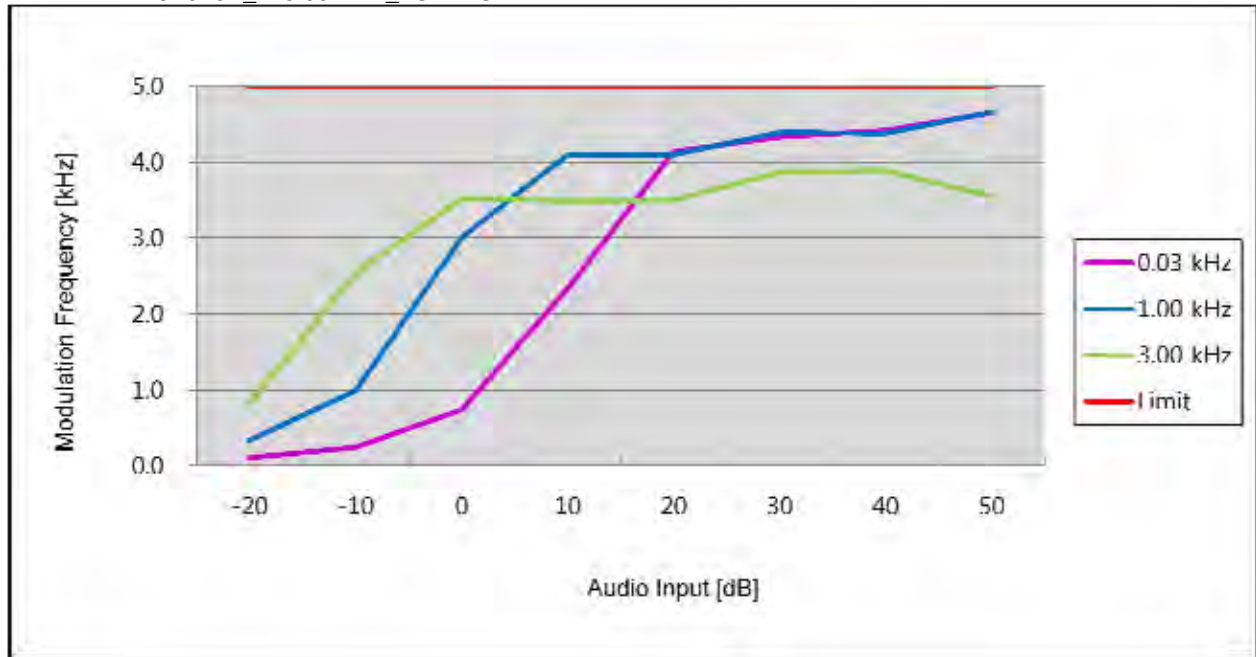

16K0F3E_148.05 MHz_LOW POWER

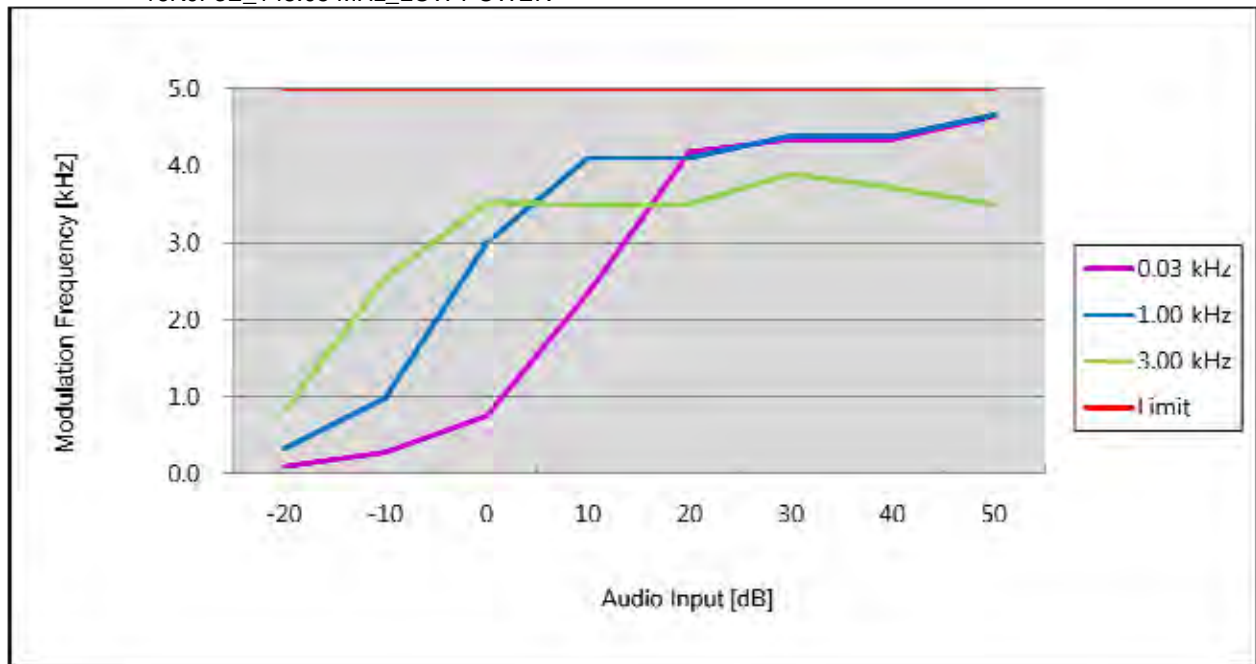

Negative Peaks

16K0F3E_138.05 MHz_HIGH POWER

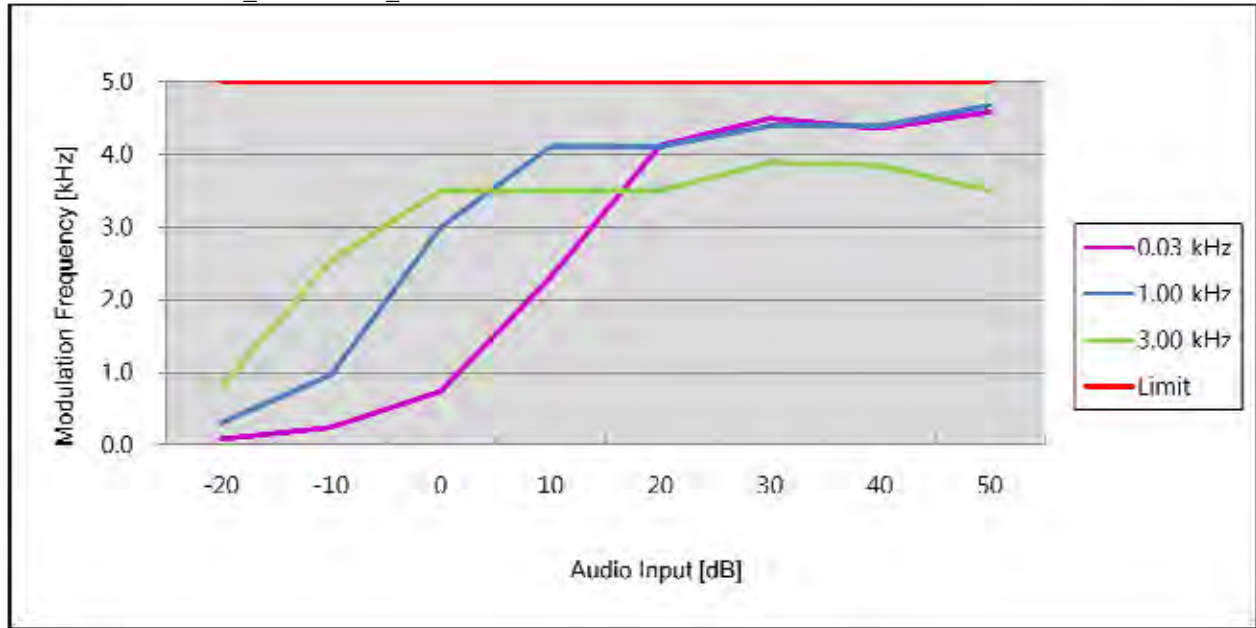

16K0F3E_143.95 MHz_HIGH POWER

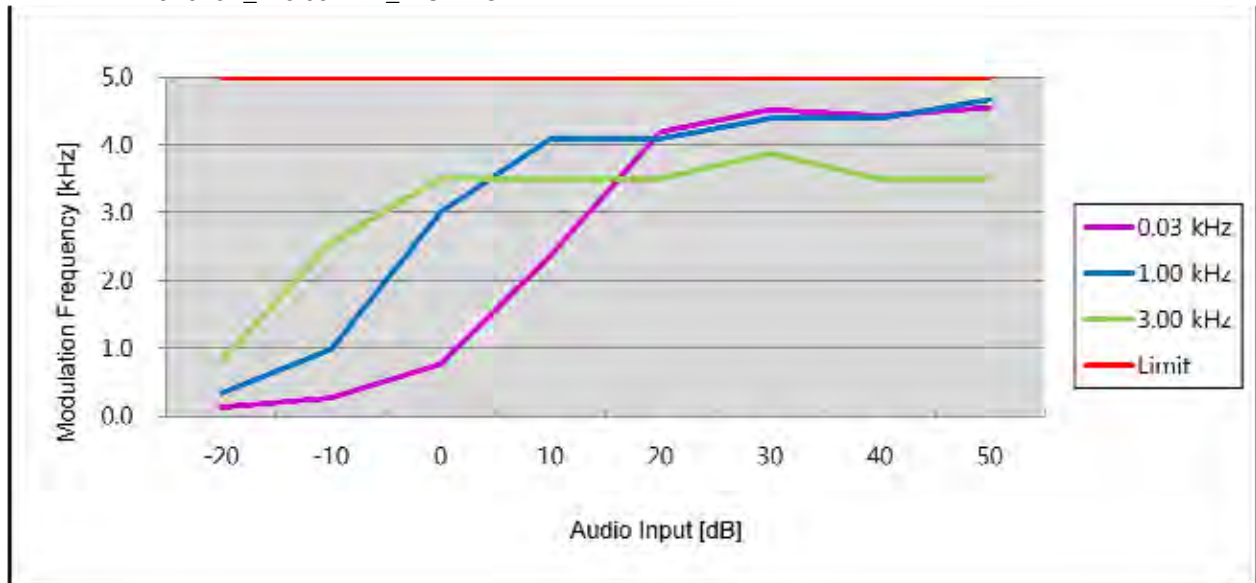

16K0F3E_148.05 MHz_HIGH POWER

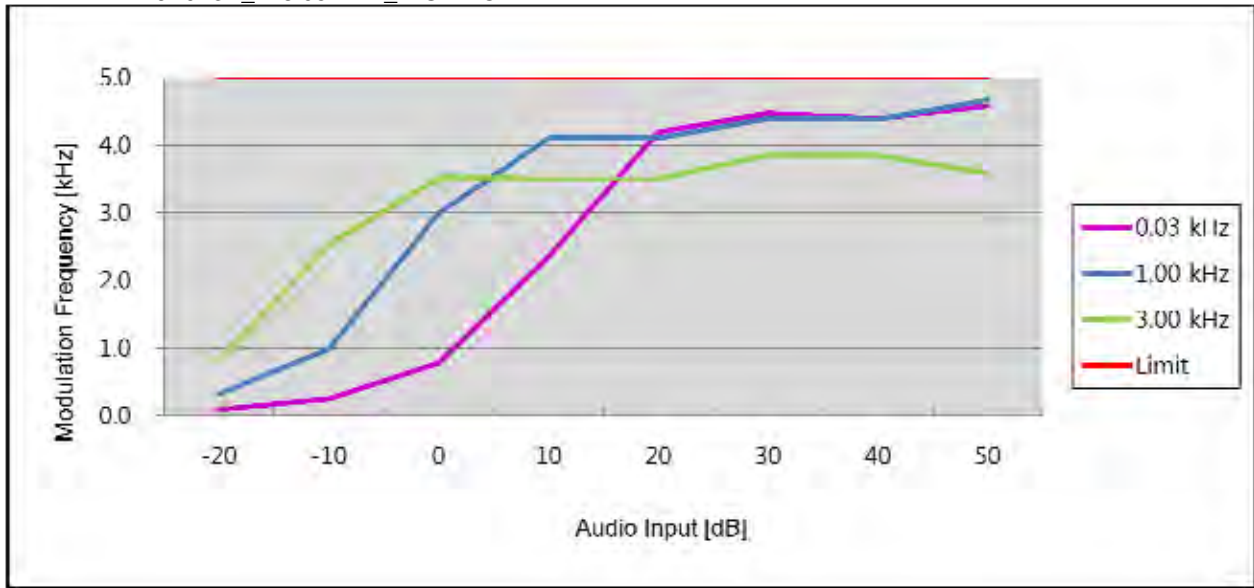

16K0F3E_138.05 MHz_LOW POWER

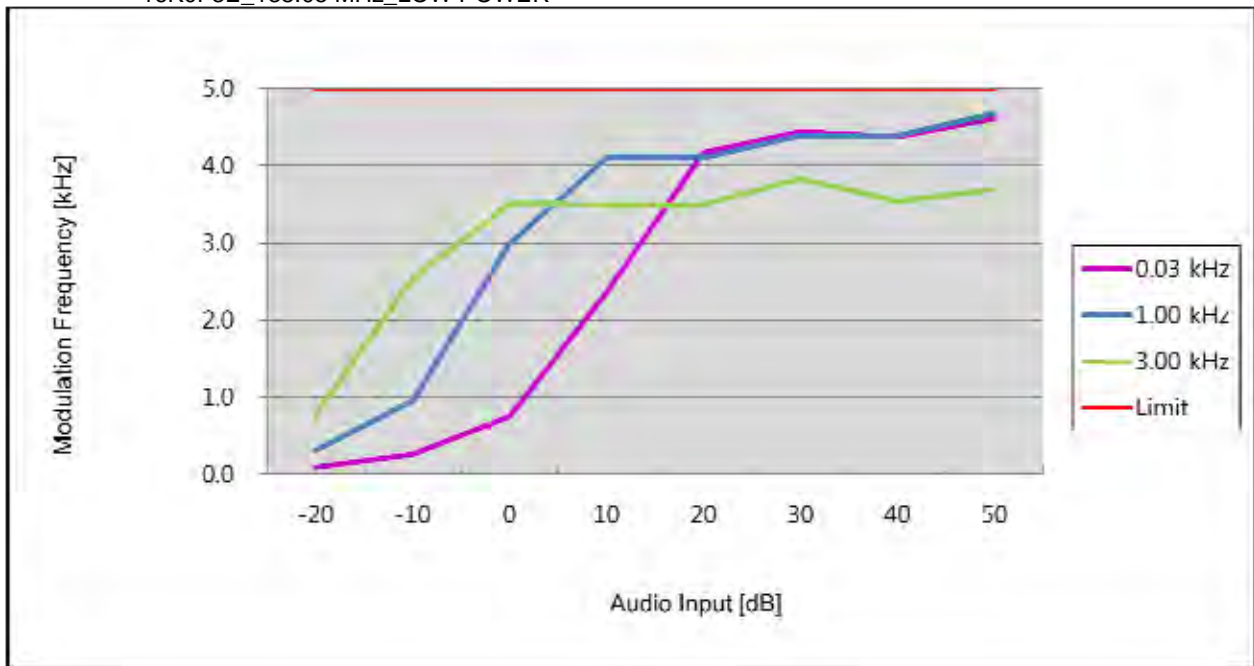

16K0F3E_143.95 MHz_LOW POWER

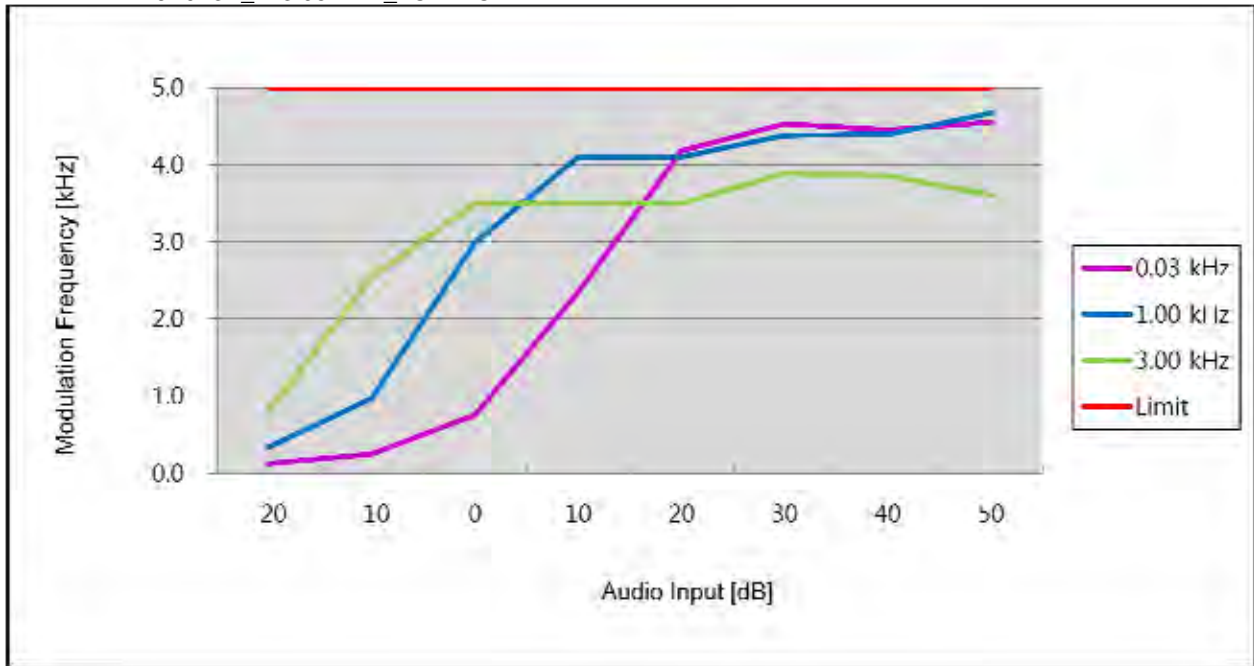

16K0F3E_148.05 MHz_LOW POWER

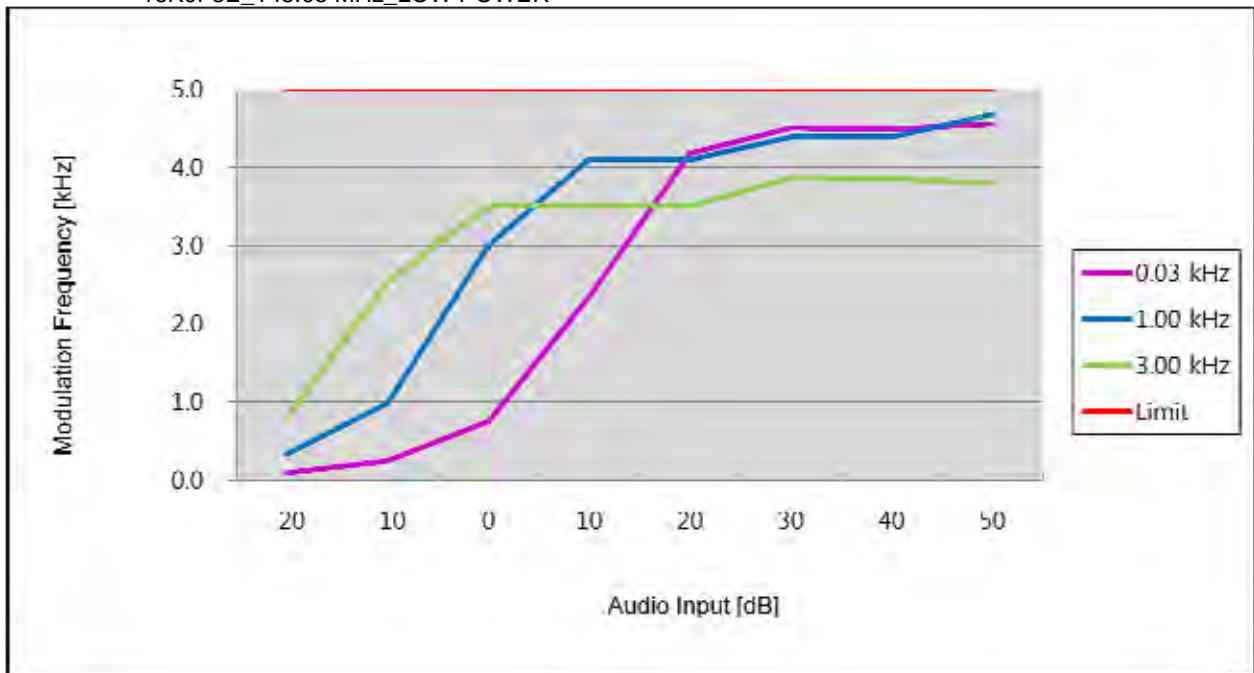

11K0F3E For IC

Positive Peaks

11K0F3E_138.05 MHz_HIGH POWER

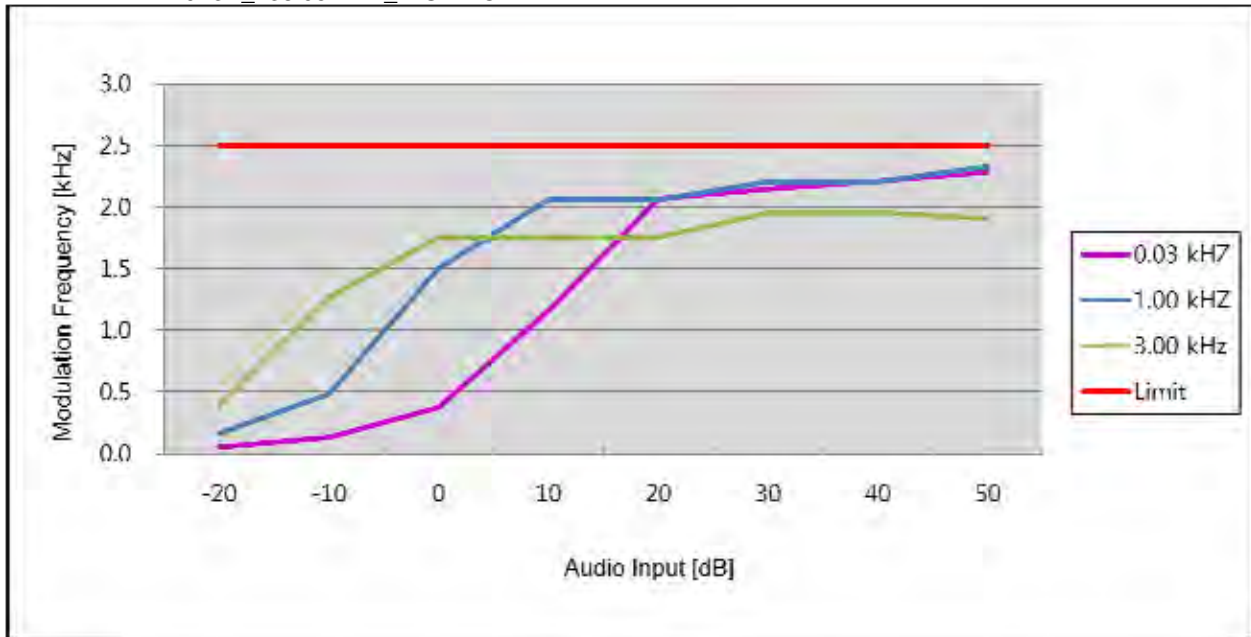

11K0F3E_143.95 MHz_HIGH POWER

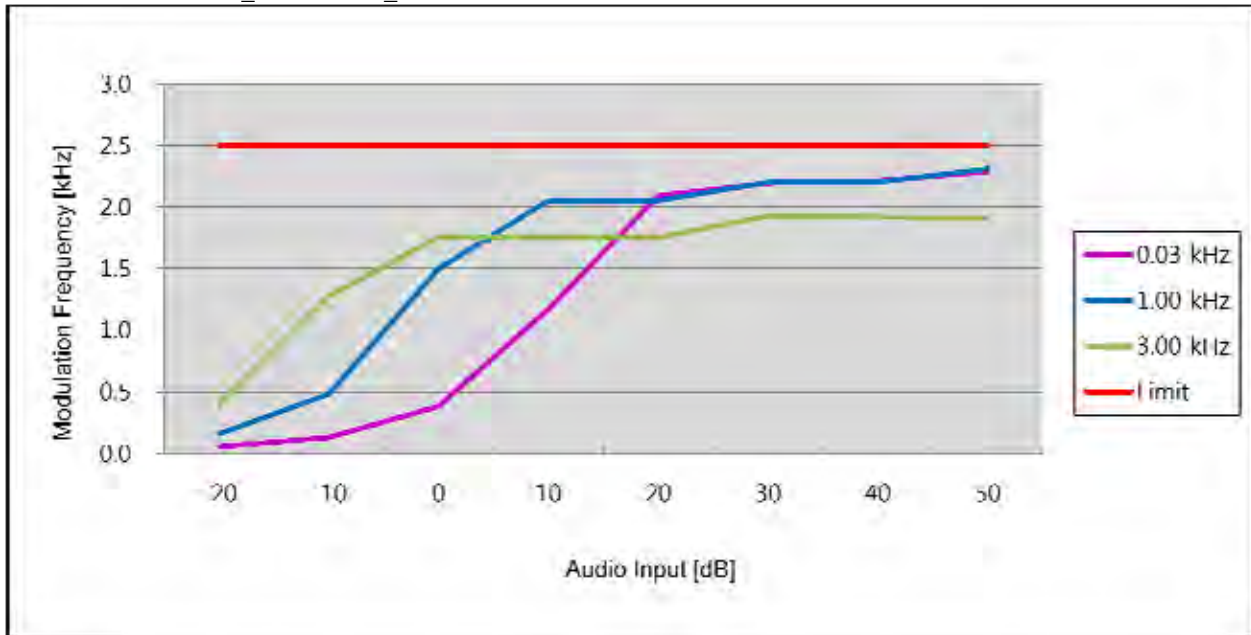

11K0F3E_148.05 MHz_HIGH POWER

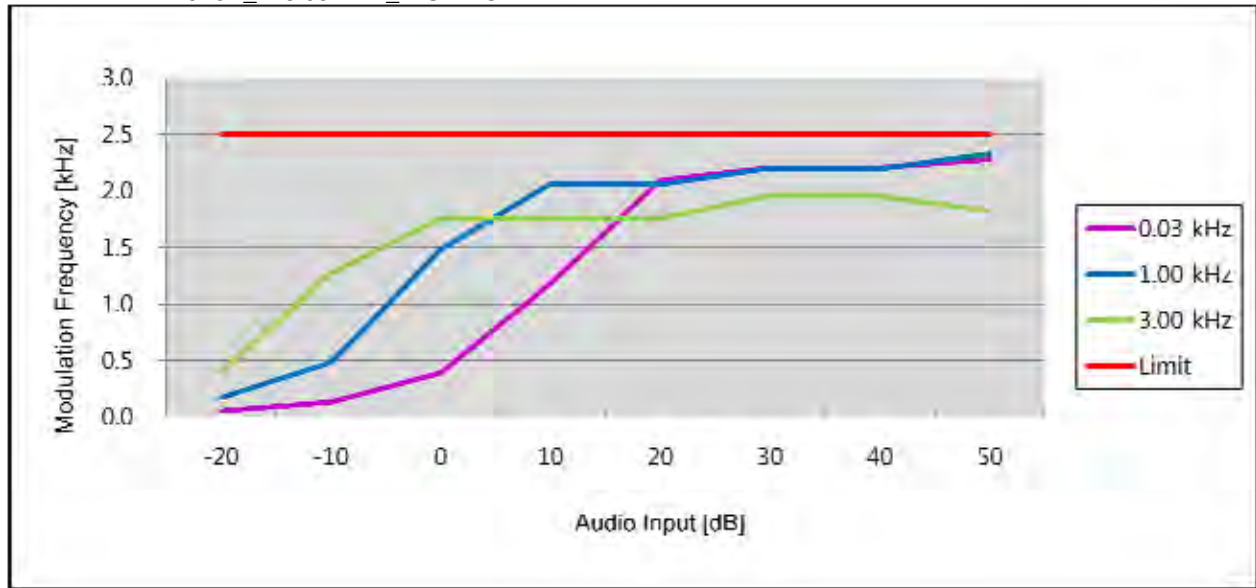

11K0F3E_138.05 MHz_LOW POWER

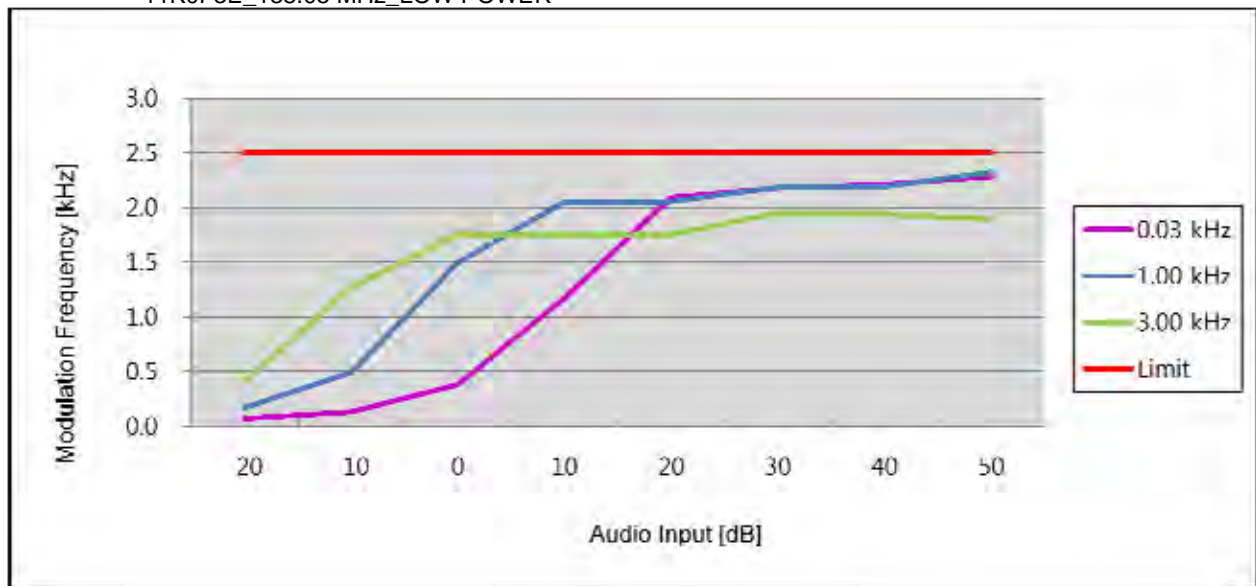

11K0F3E_143.95 MHz_LOW POWER

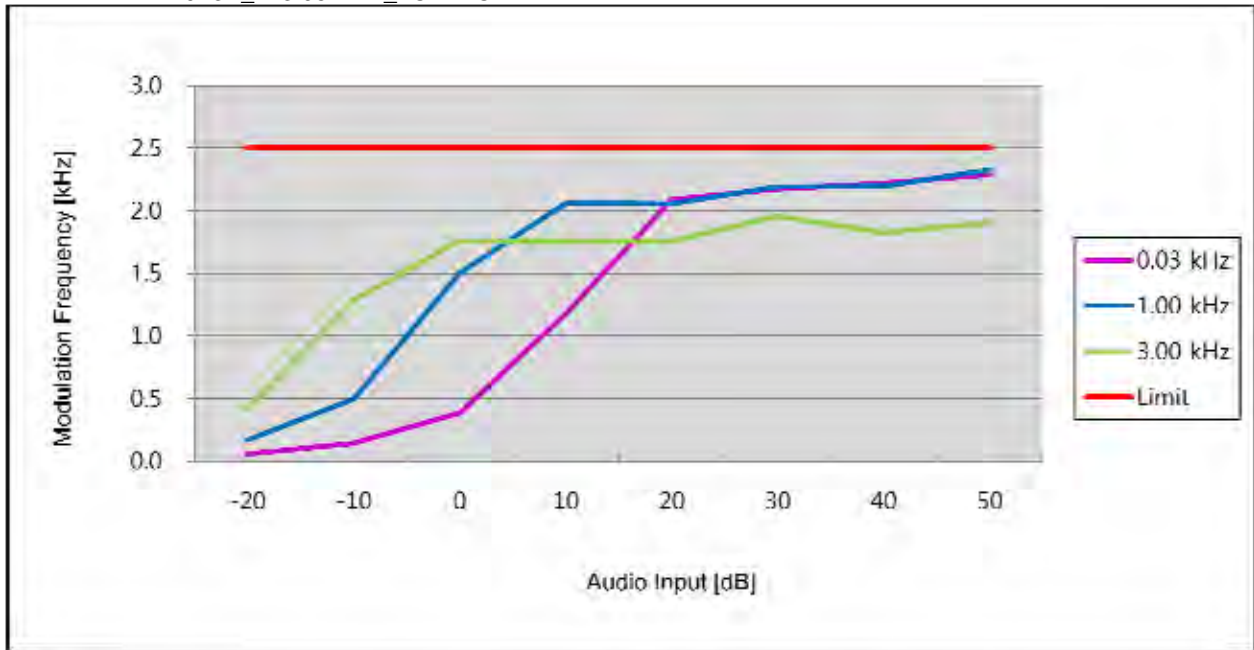

11K0F3E_148.05 MHz_LOW POWER

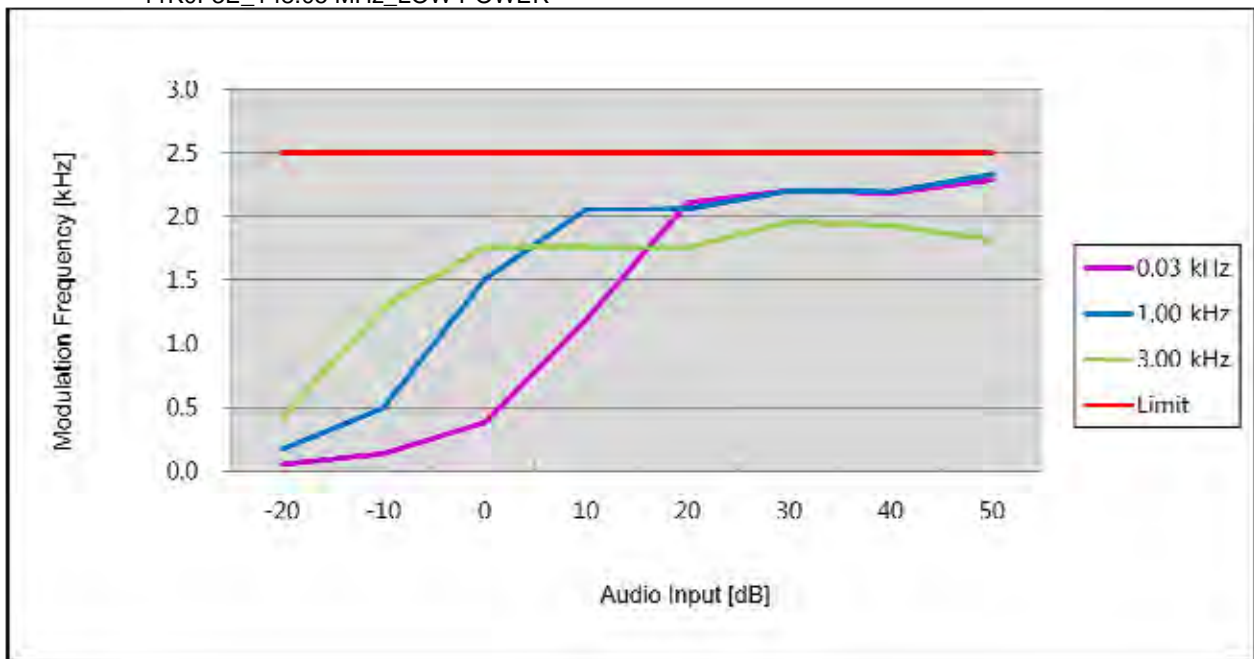

Negative Peaks

11K0F3E_138.05 MHz_HIGH POWER

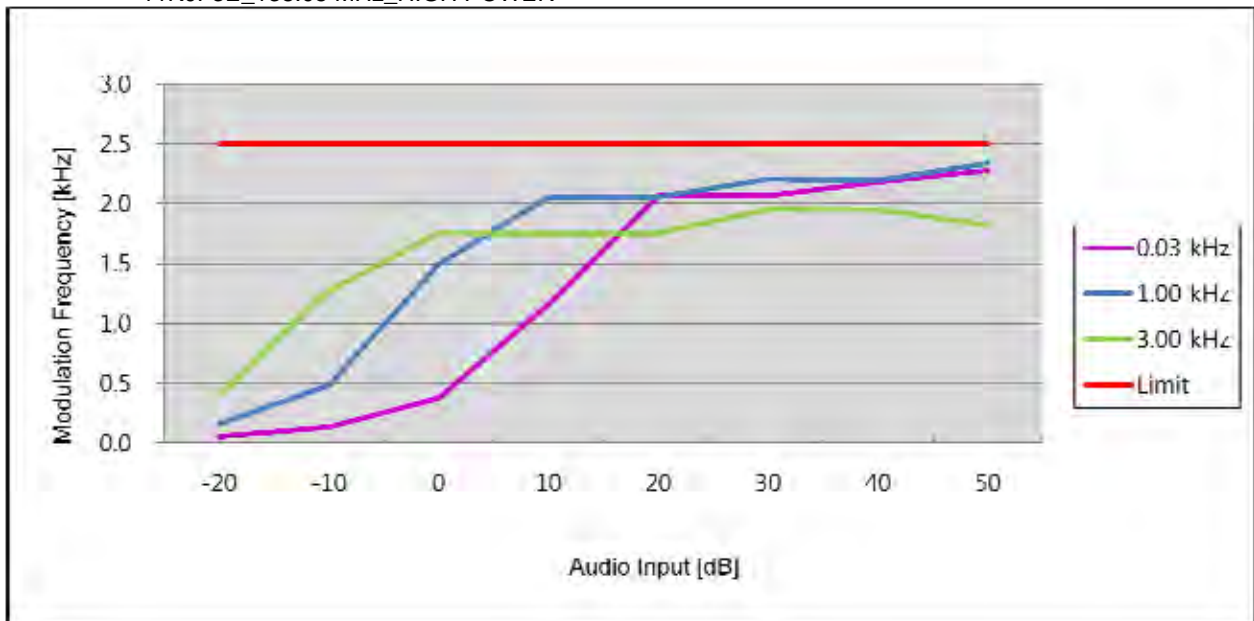

11K0F3E_143.95 MHz_HIGH POWER

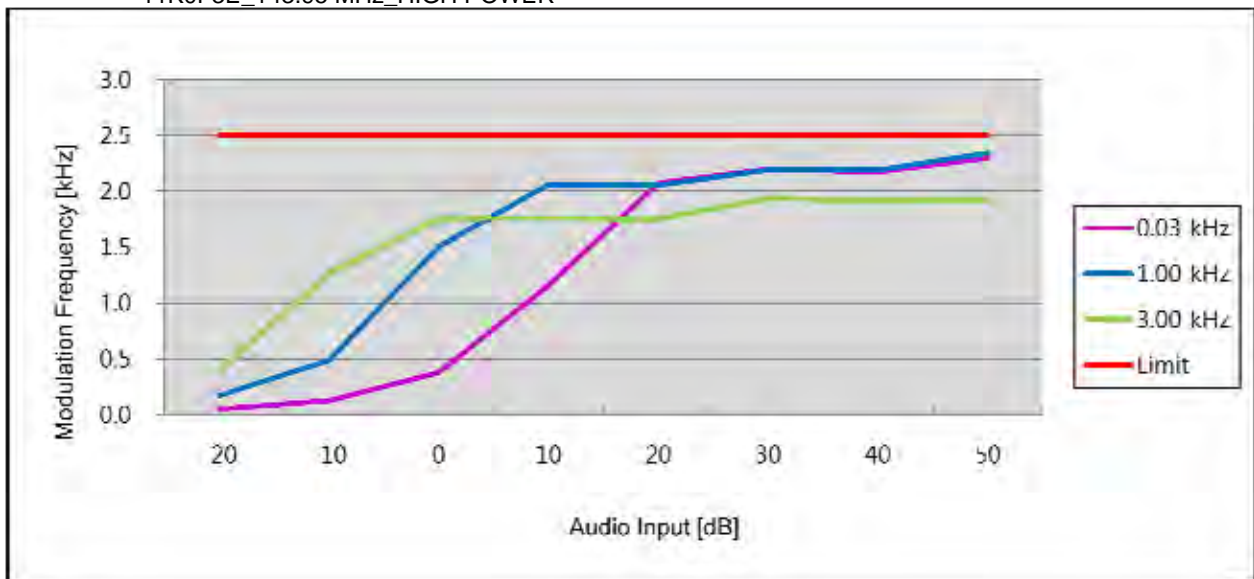

11K0F3E_148.05 MHz_HIGH POWER

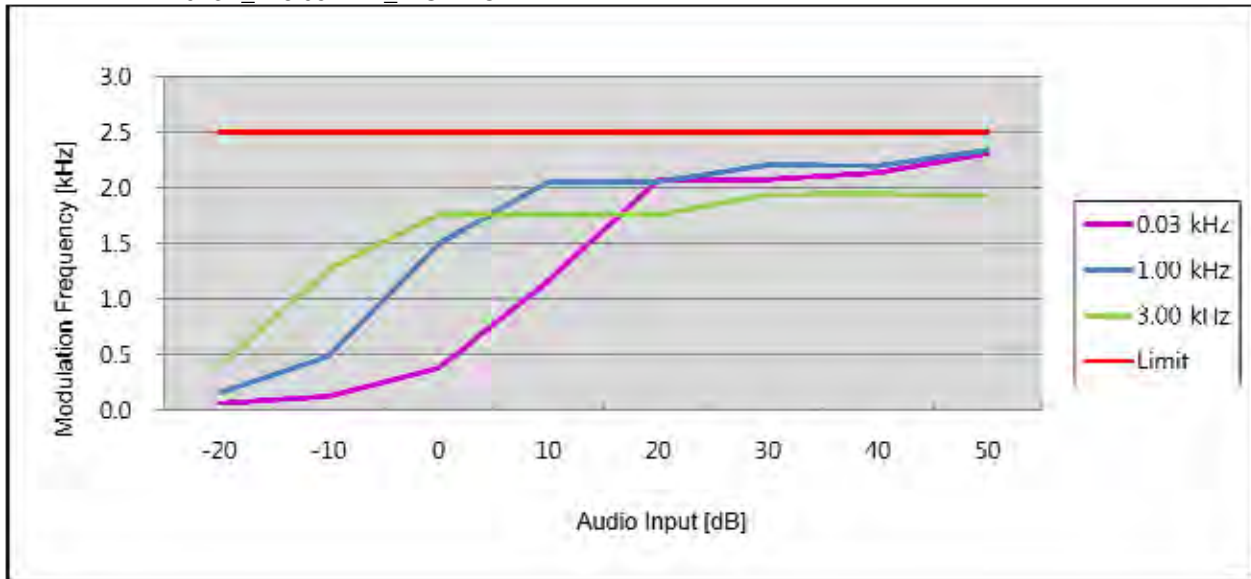

11K0F3E_138.05 MHz_LOW POWER

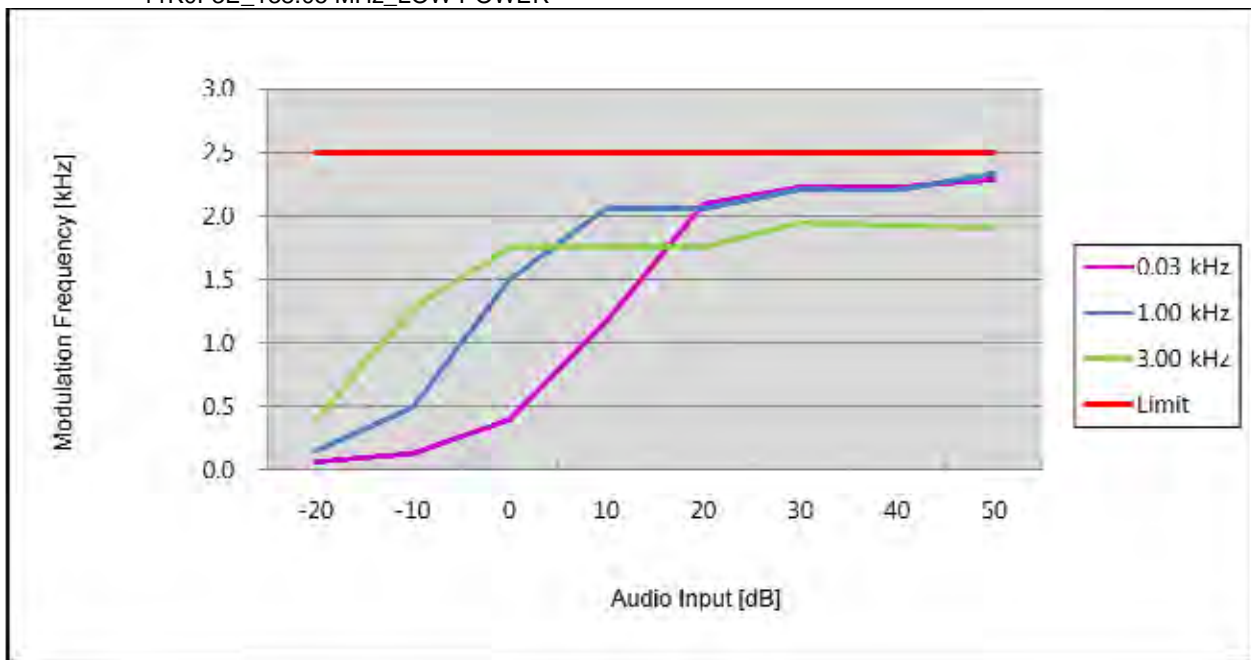

11K0F3E_143.95 MHz_LOW POWER

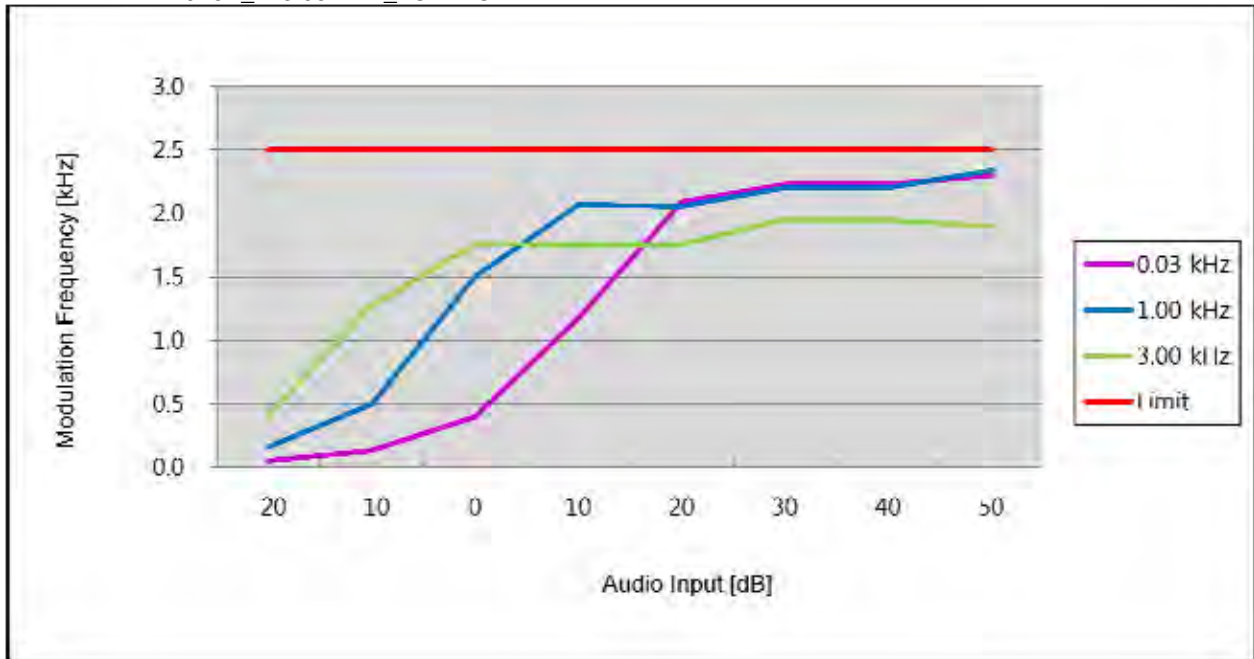

11K0F3E_148.05 MHz_LOW POWER

