



TEST REPORT

REGULATION : FCC Part 2, 90, 90.210

Applicant	Testing Laboratory
Kenwood Corporation 1-16-2, Hakusan, Midori-ku, Yokohama-shi Kanagawa, 226-8525 Japan Tel.: +81 45 939 6254 Fax.: +81 45 939 7097	Intertek Japan K. K. Kashima Laboratory 3-2, Sunayama, Kamisu-shi, Ibaraki-ken 314-0255 Japan Tel.: +81 479 40 1097 Fax.: +81 479 46 1788 Intertek Japan K. K. Tochigi Laboratory 870 Nakaawano, Kanuma-shi, Tochigi-ken 322-0306 Japan Tel.: +81 289 86 7121 Fax.: +81 289 86 7126 URL: http://www.japan.intertek-etlsemko.com

Equipment type	UHF DIGITAL BASE-REPEATER
Trademark	KENWOOD
Model(s)	NXR-810-K
Serial No.	None
FCC ID	K44422400
Test Result	Complied
Report Number	JT10040003
Report issue date	May 25, 2010

This report is for the exclusive use of Intertek's Client and is provided pursuant to the agreement between Intertek and its Client. Intertek's responsibility and liability are limited to the terms and conditions of the agreement. Intertek assumes no liability to any party, other than to the Client in accordance with the agreement, for any loss, expense or damage occasioned by the use of this report. Only the Client is authorized to permit copying or distribution of this report and then only in its entirety. Any use of the Intertek name or one of its marks for the sale or advertisement of the tested material, product or service must first be approved in writing by Intertek. The observations and test results in this report are relevant only to the sample tested. This report by itself does not imply that the material, product, or service is or has ever been under an Intertek certification program.

Approved by

Kazuo Gokita

[Manager]

Tested by

Atsuyuki Morishima

In Accordance with FCC Rules and Regulations, Volume II, Part 2 and 90

Sub-part 2.1033

(c)(1) Applicant and Manufacture Information	
APPLICANT	
Company	: Kenwood Corporation
Address	: 1-16-2, Hakusan, Midori-ku, Yokohama-shi, Kanagawa, 226-8525 Japan
Contact Person	: Tamaki Shimamura Manager, Communications Equipment Division
MANUFACTURER	
Company	: Kenwood Corporation
Address	: 1-16-2, Hakusan, Midori-ku, Yokohama-shi, Kanagawa, 226-8525 Japan
(c)(2) FCC ID	
FCC ID	: K44422400
Model number	: NXR-810-K
Serial number	: None
(c)(3) Instruction Manual(S)	
Instruction manual(s)	: Please refer to attached Exhibits F
(c)(4) Type of Emission	
Emission Designation	: 16K0F3E(Wide) /11K0F3E(Narrow) 8K30F1E(Narrow) / 8K30F1D(Narrow) / 8K30F7W(Narrow) 4K00F1E(Very Narrow) / 4K00F1D(Very Narrow) / 4K00F7W(Very Narrow) 4K00F2D(Very Narrow)
(c)(5) Frequency range	
Frequency Range	: 450 MHz to 512 MHz
(c)(6) Power Rating	
Output Power	: 5 to 40 W
Type	: Continuously Variable
(c)(7) Maximum Power Rating	
Output Power	: 40 W
(c)(8): Voltages & currents in all elements in final RF stage, including final transistor or solid-state device	
Collector Current	: 13.0 A (Maximum)
Collector Voltage	: DC 13.6 V
Supply Voltage	: DC 13.6 V
Other Information	
Number of Channel	: 30
Maximum Deviation	: 5 kHz / 2.5kHz
Frequency Stability	: 0.5 ppm
Antenna Impedance	: 50 Ω Norminal
Note	

TABLE OF CONTENTS

	Page
SECTION 1. GENERAL INFORMATION	4
SECTION 2. SUMMARY OF TEST RESULT	5
SECTION 3. TEST AND MEASUREMENT DATA	6
SECTION 4. INFORMATION ABOUT EUT AND SUPPORT EQUIPMENT(S)	7
SECTION 5. SUPPORT EQUIPMENT	8
SECTION 6. USED CABLE(S)	9
SECTION 7. TEST CONFIGURATION	10
SECTION 8. OPERATING CONDITION	11
SECTION 9. MEASUREMENT UNCERTAINTY	12
SECTION 10. TEST DATA	
10.1 Carrier Output Power (Conducted)	13
10.2 Unwanted Emissions (Transmitter Conducted)	15
10.3 Field Strength of Spurious Radiation	18
10.4 Emission Masks (Occupied Bandwidth)	22
10.5 Transient Frequency Behavior	29
10.6 Audio Frequency Response / Audio Low Pass Filter (Voice Input)	36
10.7 Modulation Limiting	39
10.8 Frequency Stability (Temperature Variation)	43
10.9 Frequency Stability (Voltage Variation)	46
10.10 Necessary Bandwidth and Emission Bandwidth	48
APPENDIX PHOTOGRAPHS	

SECTION 1. GENERAL INFORMATION

TEST PERFORMED

Location	Tochigi No2 Test Site and Kashima No.1 Test Site		
EUT Received	April 20, 2010		
Date of Test	April 26, 2010	to	May 20, 2010
Standard Applied	FCC Part 2, 90, 90.210		
Measurement Method	ANSI/TIA-603-C-2004		
Deviation from Standard(s)	Not applicable		

QUALIFICATIONS OF TESTING LABORATORY (Kashima Lab.)

ACCREDITATION	SCOPE	LAB. CODE	Remarks
NVLAP	EMC Testing	100290-0	USA
VLAC	EMC Testing	VLAC-008-1	JAPAN
BSMI	EMC Testing	SL2-IN-E-6008	TAIWAN
Vietnam MIC	EMC Testing	62-QD-QLCL	Vietnam
FILING			
VCCI	EMC Testing	R-788, C-278, C-279, T-1716, T-1717,G-119 R-274, C-280, C-281, T-1718, T-1719,G-120 R-272, C-276, C-277, T-1720, T-1721 R-576, C-590, T-1722, G-121	JAPAN
FCC	EMC Testing	Designation Number:JP0008	USA
IC	EMC Testing	IC-2042K-1, IC-2042K-3	CANADA
CB-Scheme	EMC Testing	TL222	IECEE
SAUDI ARABIA	EMC Testing	N/A	

QUALIFICATIONS OF TESTING LABORATORY (Tochigi Lab.)

ACCREDITATION	SCOPE	LAB. CODE	Remarks
VLAC	EMC Testing	VLAC-008-5	JAPAN
BSMI	EMC Testing	SL-2-IN-E-6017, SL-2-AI-E-6017	TAIWAN
FILING			
VCCI	EMC Testing	R-257, C-260, C-284, T-1763, T-1737,G-124 R-258, C-261, C-285, T-1738, T-1739 R-259, C-262, T-1740,G-125	JAPAN
FCC	EMC Testing	Designation Number:JP0011	USA
IC	EMC Testing	IC-2042P-1, IC-2042P-2	CANADA
SAUDI ARABIA	EMC Testing	N/A	

ABBREVIATIONS

EUT	Equipment Under Test	DoC	Declaration of Conformity
AMN	Artificial Mains Network	ISN	Impedance Stabilization Network
LISN	Line Impedance Stabilization Network	Q-P	Quasi-peak
AMP	Amplifier	AVG	Average
ATT	Attenuator	PK	Peak
ANT	Antenna	Cal	Calibration
BBA	Broadband Antenna	N/A	Not applicable or Not available
DIP	Dipole Antenna	LCD	Liquid-Crystal Display
AE	Associated Equipment	4LEVEL FSK	4LEVEL Frequency Shift Key
GMSK	Gaussian Maximum Shift Key	CW ID	Continuously Repeating bit stream
FM	Frequency Modulation	C4FM	Constant envelope 4 Level FM
PTT	Push to Talk	AFC	Automatic frequency control

SECTION 2. SUMMARY OF TEST RESULT

FCC Part2	Part90	TEST ITEM	RESULTS
2.1046 (a)	-	Carrier Output Power (Conducted)	PASS
2.1051	90.210	Unwanted Emissions (Transmitter Conducted)	PASS
2.1053 (a)	90.210	Field Strength of Spurious Radiation	PASS
2.1049 (c) (1)	90.210	Emission Masks (Occupied Bandwidth)	PASS
-	90.214	Transient Frequency Behavior	PASS
2.1047 (a)	90.242 (b) (8)	Audio Low Pass Filter (Voice Input)	PASS
2.1047 (a)	-	Audio Frequency Response	PASS
2.1047 (b)	-	Modulation Limiting	PASS
2.1055 (a) (1)	90.213 (a)	Frequency Stability (Temperature Variation)	PASS
2.1055 (d) (1)	90.213 (a)	Frequency Stability (Voltage Variation)	PASS
-	90.203 (j)(3)	Certification required (FCC Part 90.203(j)(3))	PASS

Limitation on Results

The test result of this report is effective equipment under test itself and under the test configuration described on the report.

This test report does not assure that whether the test result taken in other testing laboratory is compatible or reproducible to the test result on this report or not.

Note:

As for the FCC Part 15 Subpart B-Unintentional Radiators, the EUT has been measured and declared as Verification by Kenwood Corporation.

SECTION 3. TEST AND MEASUREMENT DATA

All test and measurements indicated in this document were performed in accordance with the Code of Federal Regulations Title 47 Part 2, Sub-part J and Industry Canada as the following individual parts:

FCC Rule	Test Item	Tested
Part 21	Domestic Public Fixed radio Services	N.A.
Part 22	Non Cellular	N.A.
Part 22	Public Mobile Services	N.A.
Part 22	Subpart H - Cellular Radiotelephone Service	N.A.
Part 22	Alternative technologies and auxiliary service	N.A.
Part 23	International Fixed Public Radiocommunication service	N.A.
Part 24	Personal Communications Services	N.A.
Part 74	Experimental Radio Auxiliary , Special Broadcast and Other Program Distributional Services	N.A.
Part 80	Stations in the Maritime Services	N.A.
Part 80	Subpart E - general Technical Standards	N.A.
Part 80	Subpart F - Equipment Authorization for Compulsory Ships	N.A.
Part 80	Subpart K - Private Coast Stations and Marine Utility Stations	N.A.
Part 80	Subpart S - Compulsory radiotelephone Installations for Small Passenger Boats	N.A.
Part 80	Subpart T - Radiotelephone Installation Required for Vessels on the Great Lakes	N.A.
Part 80	Subpart U - Radiotelephone Installations Required by the Bridge-to-Bridge Act	N.A.
Part 80	Subpart V - Emergency Position Indicating Radiobeacons (EPIRB'S)	N.A.
Part 80	Subpart W - Global Maritime Distress and Safety System (GMDSS)	N.A.
Part 80	Subpart X - Voluntary Radio Installations	N.A.
Part 87	Aviation Services	N.A.
Part 90	Private Land Mobile radio Services	YES
Part 94	Private Operational - Fixed Microwave Service	N.A.
Part 95	Subpart A - General Mobile radio Service	N.A.
Part 95	Subpart C - Radio Control (R/C) radio Service	N.A.
Part 95	Subpart D - Citizens Band (CB) Radio Service	N.A.
Part 95	Subpart E -Family radio Service	N.A.
Part 95	Subpart F -Interactive Video and Data Service (IVDS)	N.A.
Part 97	Amateur Radio Service	N.A.
Part 101	Fixed Microwave Service	N.A.

IC Rule	Test Item	Tested
RSS-119	Land Mobile and Fixed Radio Transmitters and Receivers	N.A.
RSS-Gen	General Requirements and Information for the Certification of Radiocommunication Equipment	N.A.

SECTION 4. INFORMATION ABOUT EUT AND SUPPORT EQUIPMENT(S)

4.1 List of System Configuration

Symbol	Item	Model No.	Serial No.	Manufacture	Remarks
A	UHF DIGITAL BASE-REPEATER	NXR-810-K	None	KENWOOD	EUT
Power Ratings of EUT :		DC 13.6 V (DC 10.8 - 15.6 V)		13.0 A Maximum	
Power Supply :		DC 13.6 V +/- 15 %			
Condition of Equipment		Proto type			
Type		Rack Mount type			
Suppression Devices		No Modifications by the laboratory were made to the device			

4.2 Port(s)/Connector(s)

Port Name	Connector Type	Connector Pin	Remarks
RX IN	BNC	2 pin	
Microphone	RJ-45	8 pin	
Control I/O	D-sub	25 pin	
TX OUT	N	2 pin	
TEST / SPKR	MOLEX 1625-15p	15 pin	
N SYNC 1	RJ-11	4 pin	
N SYNC 2	RJ-11	4 pin	
DC 13.6V	JST VLR-02V	2 pin	
REF IN (for Serviceman use only)	BNC	2 pin	

4.3 Highest Frequency Oscillator(s)/Crystal(s)

Base Clock	Operating Frequency	Board Name	Remarks
520 MHz	520 MHz	TXRX Unit	

SECTION 5. SUPPORT EQUIPMENT

The EUT was supported by the following equipment during the test.

Symbol	Item	Model No.	Serial No.	Manufacture	FCC ID
B	Dummy Load	None	None	STACK	N/A
C	Microphone	KMC-35	None	KENWOOD	N/A
D	Controller	None	None	None	N/A
E	DC Power Supply	GZV4000	90290932	Daiichi Denpa Kogyo	N/A
F	DC Power Supply	GZV4000	90290931	Daiichi Denpa Kogyo	N/A
G	Dummy Load	CT-150NP	1138693	TME	N/A
H	External Speaker	KES-5	None	KENWOOD	N/A
I	BASE REPEATER	NXR-710-K	None	KENWOOD	K44422300

Supplied Power:		
E,F	AC	100V,60Hz

SECTION 6. USED CABLE(S)

The following cable(s) was used for the test.

No.	Name	Length (m)	Shield	Connector	Ferrite core
1	Microphone Cable	0.60	No	Plastic	
2	D-sub Cable	1.20	No	Plastic	
3	Coaxial cable	0.90	Yes	Metal	
4	Speaker Cable	2.80	No	Plastic	
5	Modular Cable	0.18	No	Plastic	
6	Modular Cable	0.18	No	Plastic	
7	Power Cable (DC) for EUT	4.00	No	Plastic	Removable x1
8	Power Cable (DC) for (I)	4.00	No	Plastic	Removable x1
9	Power Cable for DC Power Supply	1.80	No	-	
10	Power Cable for DC Power Supply	1.80	No	-	

SECTION 7. TEST CONFIGURATION

Details of Configuration and Connection

Example: Case of Section 10.3 Test

- * : EUT
- : Joint Connector
- : Ferrite core

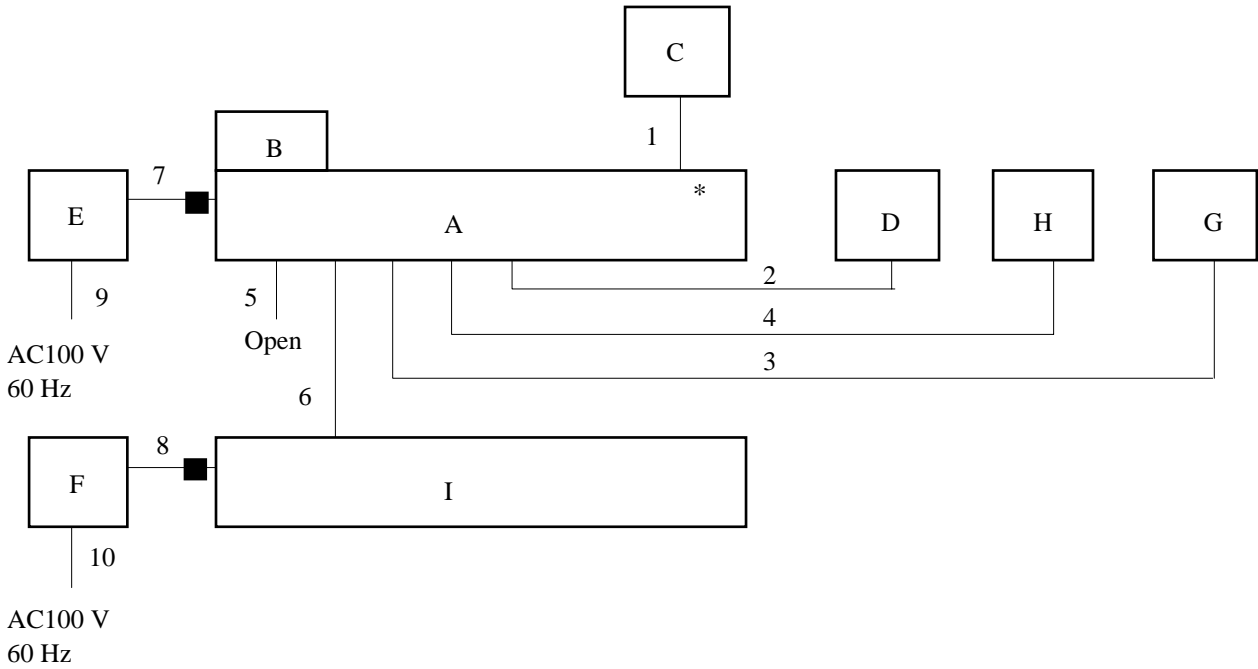

SECTION 8. OPERATING CONDITION

The EUT was operated under the following condition during the test.

8.1 Operating Condition

The test was carried out under Transmit mode.

(Frequency : [Low Band] 450.05MHz, [Middle Band] 481.05MHz, [High Band] 511.95MHz)

(Output Power : [High Power] 40 W, [Low Power] 5 W)

EUT was examined in the operating conditions that had maximum emissions.

8.2 Operating Flow [Transmit mode]

Following operations were performed continuously.

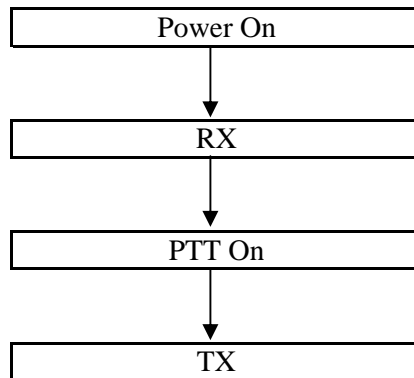

SECTION 9. MEASUREMENT UNCERTAINTY

Carrier Output Power (Conducted)	U _{lab}	Utia-603-c	
	+/- 0.29dB (<i>k</i> = 2)	+/- 0.59	dB
Unwanted Emissions (Transmitter Conducted)			
	+/- 2.19 dB (<i>k</i> = 2)	+/- 1.1	dB
Field Strength of Spurious Radiation			
below 1GHz	+/- 3.8dB (<i>k</i> = 2)	+/- 3.3	dB
above 1GHz	+/- 4.3dB (<i>k</i> = 2)	+/- 3.3	dB
Emission Masks (Occupied Bandwidth)			
	+/- 0.5dB (<i>k</i> = 2)	+/- 2.1	dB
Transient Frequency Behavior			
	+/- 1.10% (<i>k</i> = 2)	+/- 21.6	%
Audio Low Pass Filter (Voice Input)			
	+/- 0.1dB (<i>k</i> = 2)	+/- 1.2	dB
Audio Frequency Response			
	+/- 0.1dB (<i>k</i> = 2)	+/- 1.2	dB
Modulation Limiting			
	+/- 1% (<i>k</i> = 2)	+/- 1	%
Frequency Stability (Temperature Variation)			
	+/- 10.1Hz (<i>k</i> =2)	+/-34.2	Hz
Frequency Stability (Voltage Variation)			
	+/- 10.1Hz (<i>k</i> =2)	+/-34.2	Hz

SECTION 10. TEST DATA

10.1 Carrier Output Power (Conducted)

REGULATIONS	: FCC Part 2 Section 1046 (a)
TEST METHOD/GUIDE	: ANSI/TIA-603-C Section 2.2.1.2

Test Procedure

- 1 The EUT and test equipment were set up as shown on the following page.
- 2 The EUT was conducted to a resistive coaxial attenuator of normal load impedance.
 $RF\ Power\ (dBm) = Power\ Meter\ reading\ (dBm) + Attenuator\ Loss\ (dB) + Cable\ Loss\ (dB)$
 $RF\ Power\ (W) = 10^{(RF\ Power\ (dBm)/10)}/1000$

Measuring Equipments

No.	Equipment	Manufacture	Model No.	Serial No.	Cal Date	Cal Exp.
1	Power Meter	Hewlett Packard	E4418B	GB38410265	May 26, 09	May 31, 10
2	Power Sensor	Hewlett Packard	8482A	US37292237	May 26, 09	May 31, 10
3	Attenuator (20dB)	Aeroflex/Wenshel	66-20-34	BY4537	Mar. 12, 10	Mar. 31, 11
4	Attenuator (30dB)	Weinschel	WA-29-30-34	8923	May 15, 09	May 31, 10
5	Digital Multi Meter	FLUKE	8846A	9642018	Jul. 06, 09	Jul. 31, 10
6	DC Power Supply	Daiichi denpa kogyo	GZV4000	90290932	None	None

Measuring Cables

No.	Cable	Manufacturer	Model No.	Serial No.	Cal Date	Cal Exp.
W1	Coaxial Cable	Suhner	SUCOFLEX104	KSR00091	May 15, 09	May 31, 10

Measuring Equipment Configuration

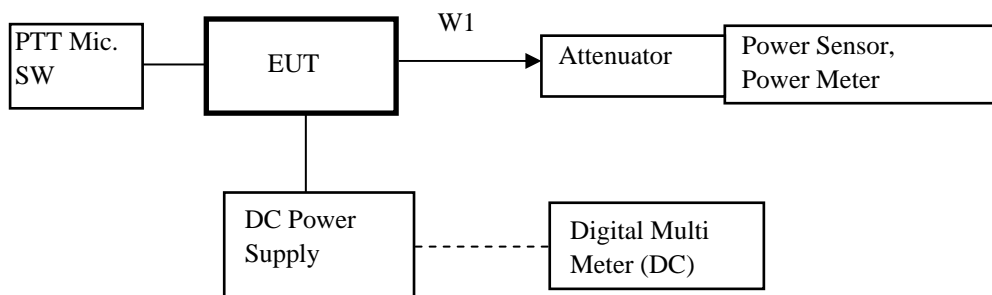

→ : RF Output

Test Results

Test date	Apr. 26, 2010	
Location	Tochigi No.2 Test Site	
temperature	20.0	[degree C]
Humidity Variation	45	[%]
Atmospheric Pressure	100.1	[kPa]
Test Engineer	Atsuyuki Morishima	

Test was carried out for all the Authorized Bandwidth.
 State the worst case (below).

No.	Frequency (MHz)	Band	Setting	RF Power (W)
1	450.05	Low	High Power	40
2	481.05	Middle	High Power	40
3	511.95	High	High Power	40
4	450.05	Low	Low Power	5
5	481.05	Middle	Low Power	5
6	511.95	High	Low Power	5

RF Power: Peak reading

10.2 Unwanted Emissions (Transmitter Conducted)

REGULATIONS : FCC Part 2 Section 1051, Part 90 Section 210

TEST METHOD/GUIDE : ANSI/TIA-603-C Section 2.2.13.2

Test Procedure

- 1 The EUT and test equipment were set up as shown on the following page.
- 2 Modulate the transmitter with a 2.5 kHz sine wave at an input Level of 16 dB greater than that necessary to produce 50 % of rated system deviation.
- 3 Adjust the spectrum analyzer for the following setting:
 - a) RBW : 10 kHz (< 1 GHz), 1 MHz (> 1 GHz).
 - b) VBW : 30 kHz (< 1 GHz), 3 MHz (> 1 GHz).
 - c) Sweep Speed : 50 msec.
 - d) Detector mode : Average power (FM Modulation) , Positive peak with peak hold (Digital Modulation)
- 4 The emissions were measured for the worst case as follows:
 - a) : within a band of frequencies defined by the carrier frequency plus and minus one channel.
 - b) : from the lowest frequency generated in the EUT and to at least the 10th harmonic of the carrier frequency, or 40 GHz, whichever is lower.

Measuring Equipments

No.	Equipment	Manufacture	Model No.	Serial No.	Cal Date	Cal Exp.
1	Audio Generator	Anritsu	MG443B	M70150	Apr. 15, 10	Apr. 30, 11
2	Attenuator (20dB)	Aeroflex/Wenshel	66-20-34	BY4537	Mar. 12, 10	Mar. 31, 11
3	Attenuator (30dB)	Weinschel	WA-29-30-34	8923	May 15, 09	May 31, 10
4	Highpass Filter	Anritsu	MP526D	6200220657	Dec. 29, 09	Dec. 31, 10
5	Modulation Analyzer	Hewlett Packard	8901B	3403A04852	Jul. 08, 09	Jul. 31, 10
6	Signal Generator	Rohde&Schwarz	SMT06	100684	Dec. 24, 09	Dec. 31, 10
7	Spectrum Analyzer	Agilent	E4407B	MY45102460	Feb. 08, 10	Feb. 28, 11
8	Digital Multi Meter	FLUKE	8846A	9642018	Jul. 06, 09	Jul. 31, 10
9	DC Power Supply	Daiichi denpa kogyo	GZV4000	90290932	None	None

Measuring Cables

No.	Cable	Manufacturer	Model No.	Serial No.	Cal Date	Cal Exp.
W1	Coaxial Cable	Suhner	SUCOFLEX104	KSR00091	May 15, 09	May 31, 10
W2	Coaxial Cable	Suhner	SUCOFLEX104	KSR00042	Mar. 12, 10	Mar. 31, 11
W4	Coaxial Cable	Pacific custom	RG-58 C/U	KSR00096	Nov. 09, 09	Nov. 30, 10
W6	Balance Cable	Nicoon	3D-2V	KSR00092	Oct. 26, 09	Oct. 31, 10

Measuring Equipment Configuration

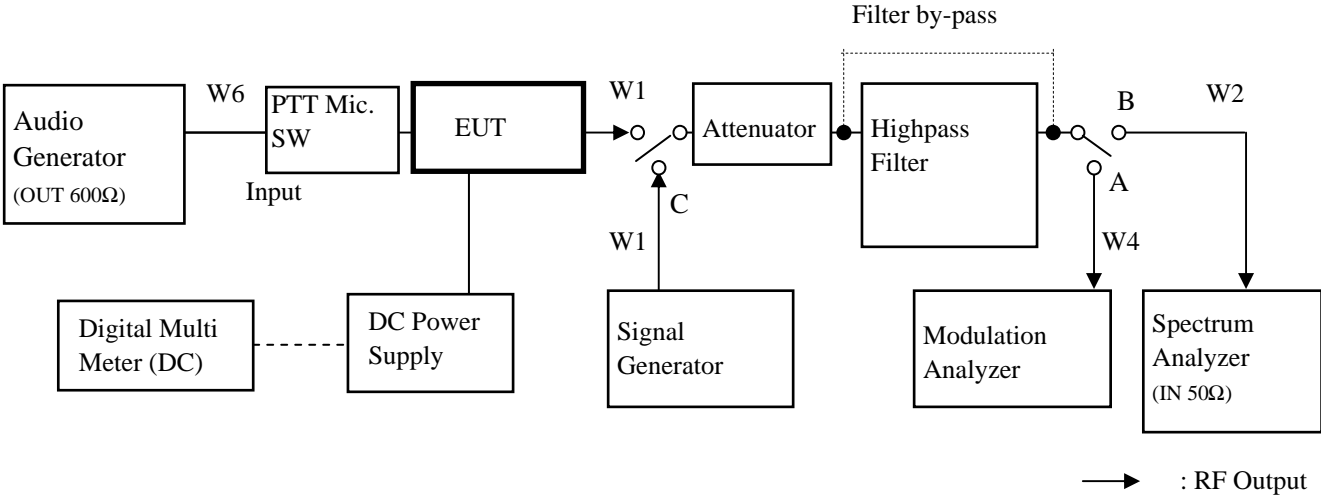

Test Results

Test date	Apr. 28, 2010	to	May 08, 2010
Location	Tochigi No.2 Test Site		
temperature	20.0 to 23.0		[degree C]
Humidity Variation	48 to 58		[%]
Atmospheric Pressure	99.4 to 99.8		[kPa]
Test Engineer	Atsuyuki Morishima		

Test was carried out for all the frequency band of section 10.1
 State the worst case (below).

State : High Power / Authorized Bandwidth 11.25 kHz

No.	Band	Frequency (MHz)	Correct Level (dBm)	Emission Level (dBc)	Mask D Limit (dBc)	Margin (dB)
1	Low	3150.35	-25.00	-71.02	-66.0	5.0
2	Middle	4810.50	-24.00	-70.02	-66.0	4.0
3	High	5119.50	-26.40	-72.42	-66.0	6.4

There is the margin of 20dB over except for the above points.

State : Low Power / Authorized Bandwidth 6 kHz

No.	Band	Frequency (MHz)	Correct Level (dBm)	Emission Level (dBc)	Mask E Limit (dBc)	Margin (dB)
1	Low	900.10	-47.30	-84.29	-62.0	22.3
2	Middle	962.10	-48.00	-84.99	-62.0	23.0
3	High	-	-	-	-62.0	-

There is the margin of 20dB over except for the above points.

Mask D Limit (dBc) = $-(50+10\text{Log}(P))$

Mask E Limit (dBc) = whichever is the lesser attenuation ; $-(55+10\text{Log}(P))$ or -65

Correct Level (dBm) = Substitute SG Level (dBm)

Emission Level (dBc) = Correct Level (dBm) - $10\text{Log}(P*1000)$

P = Carrier Level (W)

" - " = Measurement Limit

10.3 Field Strength of Spurious Radiation

REGULATIONS	: FCC Part 2 Section 1053 (a), Part 90 Section 210
TEST METHOD/GUIDE	: ANSI/TIA-603-C Section 2.2.12.2

Test Procedure

- 1 The EUT and test equipment were set up as shown on the following page.
- 2 Adjust the spectrum analyzer for the following setting:
 - a) RBW : 10 kHz (< 1 GHz), 1 MHz (> 1 GHz).
 - b) VBW : 300 kHz (< 1 GHz), 3 MHz (> 1 GHz).
 - c) Sweep Speed : 50ms.
 - d) Detector mode : Positive Peak
- 3 The transmitter was placed on a wooden turntable, and it was transmitting into non-radiating load which was also placed on the turntable.
- 4 The measurement antenna was placed at a distance of 3 meters from the EUT. During the tests, the antenna height and polarization as well as EUT azimuth were varied in order to identify the maximum level of emissions from the EUT. The test was performed by placing the EUT on 3-orthogonal axis.
- 5 The frequency range up to tenth harmonic of the fundamental frequency was investigated.
- 6 Remove the EUT and replace it with substitution antenna. A signal generator was connected to the substitution antenna by a non-radiating cable. The absolute levels of the spurious emissions were measured by the substitution.
- 7 Spurious emissions in dB = 10 Log (TX power in Watts/0.001) – the absolute level

Measuring Equipments

No.	Equipment	Manufacture	Model No.	Serial No.	Cal Date	Cal Exp.
1	Dummy Load	TME	CT-150NP	1138693	Oct. 01, 09	Oct. 31, 10
2	Dipole Antenna(TX)	Schwarzbeck	UHA9105	AM0082002	May 18, 09	May 31, 10
3	D.R.G Antenna(TX)	Schwarzbeck	3117	KSR00038	Aug. 13, 09	Aug. 31, 10
4	Tri-log Antenna(RX)	Schwarzbeck	VULB9168	218	Mar. 31, 10	Mar. 31, 11
5	D.R.G Antenna(RX)	EMCO	3115	9903-5699	Apr. 21, 10	Apr. 30, 11
6	Attenuator(10dB)	HUBER+SUHNER	6810.17B	KSR0044	Feb. 05, 10	Feb. 28, 11
7	Attenuator(6dB)	TAMAGAWA	CFA-01(NPJ-6)	None	May. 20, 09	May. 31, 10
8	Attenuator(6dB)	Hewlett Packard	8493C	18493	Apr. 13, 10	Apr. 30, 11
9	Pre-Amplifier	Hewlett Packard	8449B	3008A01182	Apr. 13, 10	Apr. 30, 11
10	Pre-Amplifier	Hewlett Packard	8447D	2727A05324	May. 20, 09	May. 31, 10
11	Step Attenuator	Hewlett Packard	8494B	2805A14563	May. 20, 09	May. 31, 10
12	RF Switch	Intertek Japan	ACX-150	None	May. 20, 09	May. 31, 10
13	Spectrum Analyzer	Agilent	E4407B	MY45102460	Feb. 08, 10	Feb. 28, 11
14	Signal Generator	Rohde&Schwarz	SMT06	100684	Dec. 24, 09	Dec. 31, 10
15	Digital Multi Meter	FLUKE	8846A	9642018	Jul 06, 09	Jul. 31, 10
16	DC Power Supply	Daiichi denpa kogyo	GZV4000	90290932	None	None
17	DC Power Supply	Daiichi denpa kogyo	GZV4000	90290931	None	None

Measuring Cables

No.	Cable	Manufacturer	Model No.	Serial No.	Cal Date	Cal Exp.
R1	Coaxial Cable	Intertek Japan	5D-2W	2R1001a	May. 20, 09	May. 31, 10
R2	Coaxial Cable	Intertek Japan	RG-177/U	2R1002	May. 20, 09	May. 31, 10
R3	Coaxial Cable	Intertek Japan	RG-5A/U	2R1003	May. 20, 09	May. 31, 10
R4	Coaxial Cable	Intertek Japan	RG-5A/U	2R1004	May. 20, 09	May. 31, 10
R5	Coaxial Cable	Intertek Japan	5D-2W	2R1005	May. 20, 09	May. 31, 10
R6	Coaxial Cable	Intertek Japan	5D-2W	2R1006	May. 20, 09	May. 31, 10
R7	Coaxial Cable	Intertek Japan	5D-2W	2R1006	May. 20, 09	May. 31, 10
R8	Coaxial Cable	Intertek Japan	5D-2W	2R1008a	May. 20, 09	May. 31, 10
R16	Coaxial Cable	Suhner	SUCOFLEX104 290799/4		Apr. 13, 10	Apr. 30, 11
R17	Coaxial Cable	Suhner	SUCOFLEX104 290800/4		Apr. 13, 10	Apr. 30, 11
W1	Coaxial Cable	Suhner	SUCOFLEX104 KSR00091		May. 15, 09	May. 31, 10
W13	Coaxial Cable	Suhner	SUCOFLEX104 KSR00207		Jun. 12, 09	Jun. 30, 10

Measuring Equipment Configuration

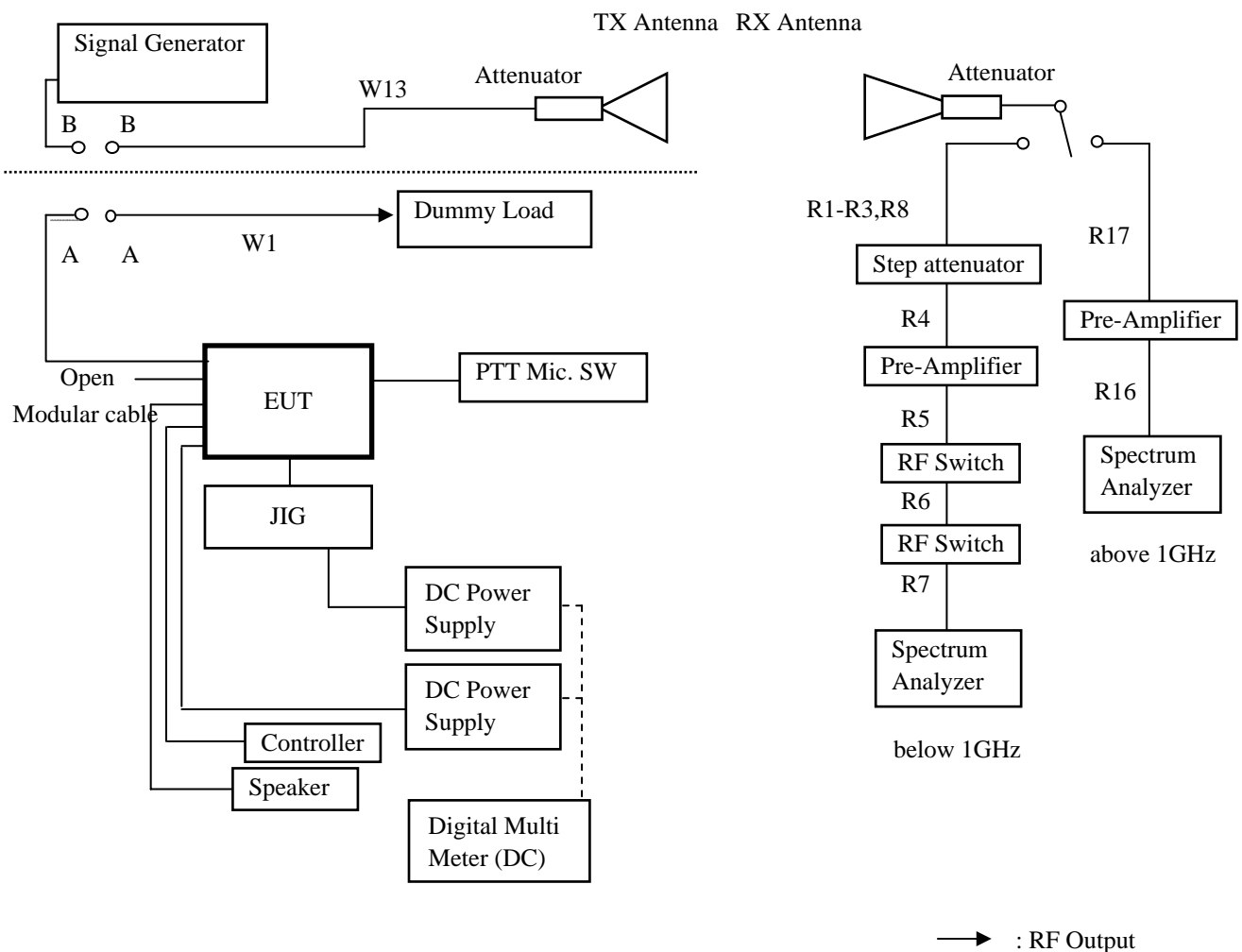

Test Results

Test date	May. 10, 2010	
Location	Tochigi No.2 Test Site	
temperature	20.0 to 25.0	[degree C]
Humidity Variation	45 to 65	[%]
Atmospheric Pressure	98.1 to 99.2	[kPa]
Test Engineer	Atsuyuki Morishima	

Test was carried out for all the frequency band of section 10.1
 State the worst case (below).

State : High Power / Authorized Bandwidth 11.25 kHz / 511.95 MHz

No	Frequency (MHz)	Pol	Reading Level (dBm)	SG Out Level (dBm)	Anten		Correct Level (dBm)	Emission Level (dBc)	Limit Level (dBc)	Margin (dB)
					na Gain (dBi)	Loss (dB)				
1	1023.90	Hor.	-42.82	-29.80	3.63	12.43	-38.6	-84.6	-66.0	18.6
		Ver.	-38.35	-25.40	3.63	12.43	-34.2	-80.2	-66.0	14.2
2	1535.85	Hor.	-49.53	-38.20	6.39	13.01	-44.8	-90.8	-66.0	24.8
		Ver.	-46.00	-31.40	6.39	13.01	-38.0	-84.0	-66.0	18.0
3	2047.80	Hor.	-53.62	-38.40	5.16	13.51	-46.8	-92.8	-66.0	26.8
		Ver.	-47.37	-29.00	5.16	13.51	-37.4	-83.4	-66.0	17.4
4	2559.75	Hor.	-55.35	-39.20	6.42	13.95	-46.7	-92.7	-66.0	26.7
		Ver.	-56.59	-39.50	6.42	13.95	-47.0	-93.0	-66.0	27.0
5	3071.70	Hor.	-50.99	-32.40	7.16	14.36	-39.6	-85.6	-66.0	19.6
		Ver.	-48.90	-28.60	7.16	14.36	-35.8	-81.8	-66.0	15.8
6	3583.65	Hor.	-55.42	-36.80	8.17	14.74	-43.4	-89.4	-66.0	23.4
		Ver.	-54.44	-34.30	8.17	14.74	-40.9	-86.9	-66.0	20.9
7	4095.60	Hor.	-48.62	-27.00	8.63	15.08	-33.5	-79.5	-66.0	13.5
		Ver.	-51.57	-29.20	8.63	15.08	-35.7	-81.7	-66.0	15.7
8	4607.55	Hor.	-54.99	-32.80	9.05	15.42	-39.2	-85.2	-66.0	19.2
		Ver.	-52.36	-30.50	9.05	15.42	-36.9	-82.9	-66.0	16.9
9	5119.50	Hor.	-48.79	-24.80	9.90	15.71	-30.6	-76.6	-66.0	10.6
		Ver.	-45.29	-21.20	9.90	15.71	-27.0	-73.0	-66.0	7.0

There is the margin of 20dB over except for the above points.

Mask D Limit (dBc) = -(50+10Log(P))

Correct Level (dBm) = Substitute SG Level (dBm) + ANT Gain (dBi) - Loss (Cable, Attenuator) (dB)

Emission Level (dBc) = Correct Level (dBm) - 10Log(P*1000)

P = Carrier Level (W)

" - " = Measurement Limit

State : Low Power / Authorized Bandwidth 6 kHz / 511.95 MHz

No	Frequency (MHz)	Pol	Reading Level (dBm)	SG Out Level (dBm)	Antenna Gain (dBi)	Loss (dB)	Correct Level (dBm)	Emission Level (dBc)	Limit Level (dBc)	Margin (dB)
1	1023.90	Hor.	-48.98	-37.00	3.63	12.43	-45.8	-82.8	-62.0	20.8
		Ver.	-42.92	-30.00	3.63	12.43	-38.8	-75.8	-62.0	13.8
2	1535.85	Hor.	-52.80	-41.90	6.39	13.01	-48.5	-85.5	-62.0	23.5
		Ver.	-51.22	-37.70	6.39	13.01	-44.3	-81.3	-62.0	19.3
3	2047.80	Hor.	-53.38	-38.20	5.16	13.51	-46.6	-83.5	-62.0	21.6
		Ver.	-51.04	-33.20	5.16	13.51	-41.6	-78.5	-62.0	16.6
4	2559.75	Hor.	-54.96	-38.80	6.42	13.95	-46.3	-83.3	-62.0	21.3
		Ver.	-53.74	-35.90	6.42	13.95	-43.4	-80.4	-62.0	18.4
5	3071.70	Hor.	-53.51	-35.60	7.16	14.36	-42.8	-79.8	-62.0	17.8
		Ver.	-50.87	-30.80	7.16	14.36	-38.0	-75.0	-62.0	13.0
6	3583.65	Hor.	-	-	8.17	14.74	-	-	-62.0	-
		Ver.	-	-	8.17	14.74	-	-	-62.0	-
7	4095.60	Hor.	-54.51	-34.30	8.63	15.08	-40.8	-77.7	-62.0	15.8
		Ver.	-55.82	-34.50	8.63	15.08	-41.0	-77.9	-62.0	16.0
8	4607.55	Hor.	-58.28	-37.70	9.05	15.42	-44.1	-81.1	-62.0	19.1
		Ver.	-58.75	-39.30	9.05	15.42	-45.7	-82.7	-62.0	20.7
9	5119.50	Hor.	-60.53	-40.80	9.90	15.71	-46.6	-83.6	-62.0	21.6
		Ver.	-58.12	-37.00	9.90	15.71	-42.8	-79.8	-62.0	17.8

There is the margin of 20dB over except for the above points.

Mask E Limit (dBc) = whichever is the lesser attenuation ; $-(55+10\log(P))$ or -65

Correct Level (dBm) = Substitute SG Level (dBm) + ANT Gain (dBi) - Loss (Cable, Attenuator) (dB)

Emission Level (dBc) = Correct Level (dBm) - $10\log(P*1000)$

P = Carrier Level (W)

" - " = Measurement Limit

10.4 Emission Masks (Occupied Bandwidth)

REGULATIONS	: FCC Part 2 Section 1049 (c) (1), Part 90 Section 210
TEST METHOD/GUIDE	: ANSI/TIA-603-C Section 2.2.11.2

Test Procedure

- 1 The EUT and test equipment were set up as shown on the following page.
- 2 For EUT supporting audio modulation, the audio signal generator was adjusted to the frequency of maximum response and with output level set for +/- 2.5 kHz deviation (or 50 % modulation). (FM modulation).
- 3 With level constant, the signal level was increased 16 dB.
- 4 Adjust the spectrum analyzer for the following setting:
 - a) RBW : 100Hz (Non modulation and Authorized Band 6 kHz),
 100Hz (Non modulation and Authorized Band 11.25 kHz),
 300Hz (Non modulation and Authorized Band 20 kHz).
 - b) VBW : 10times the RBW (Non modulation , Authorized Band 11.25 kHz and Authorized Band 20 kHz).
 - c) Sweep Speed : 8 sec.
 - d) Sampling Time : 10 times
- 5 The occupied Bandwidth was measured with the Spectrum Analyzer controls set as shown on the test results.

Measuring Equipments

No.	Equipment	Manufacture	Model No.	Serial No.	Cal Date	Cal Exp.
1	Audio Generator	Anritsu	MG443B	M70150	Apr. 15, 10	Apr. 30, 11
2	Attenuator (20dB)	Aeroflex/Wenshel	66-20-34	BY4537	Mar. 12, 10	Mar. 31, 11
3	Attenuator (30dB)	Weinschel	WA-29-30-34	8923	May 15, 09	May 31, 10
4	Modulation Analyzer	Hewlett Packard	8901B	3403A04852	Jul. 08, 09	Jul. 31, 10
5	Spectrum Analyzer	Agilent	E4407B	MY45102460	Feb 08, 10	Feb 28, 11
6	Spectrum Analyzer	Hewlett Packard	8563E	3821A09565	Apr 09, 10	Apr 30, 11
7	Digital Multi Meter	FLUKE	8846A	9642018	Jul. 06, 09	Jul. 31, 10
8	DC Power Supply	Daiichi denpa kogyo	GZV4000	90290932	None	None
9	JIG	DELL	Inspiron630m	CN-OHC416-70166-1N-OH8Q	None	None

Measuring Cables

No.	Cable	Manufacture	Model No.	Serial No.	Cal Date	Cal Exp.
W1	Coaxial Cable	Suhner	SUCOFLEX104	KSR00091	May 15, 09	May 31, 10
W3	Coaxial Cable	Suhner	SUCOFLEX104	KSR00042	Mar. 12, 10	Mar. 31, 11
W4	Coaxial Cable	Pacific custom	RG-58 C/U	KSR00096	Nov. 09, 09	Nov. 30, 10
W6	Balance Cable	Nicoon	3D-2V	KSR00092	Oct. 26, 09	Oct. 31, 10
W20	RS232C- USB Cable	SANWA Supply	USB-CVRS9	FXLA00719	None	None
W21	Programming interface Cable	Kenwood	KPG-46A	90290932	None	None

Measuring Equipment Configuration

<FM Modulation Case>

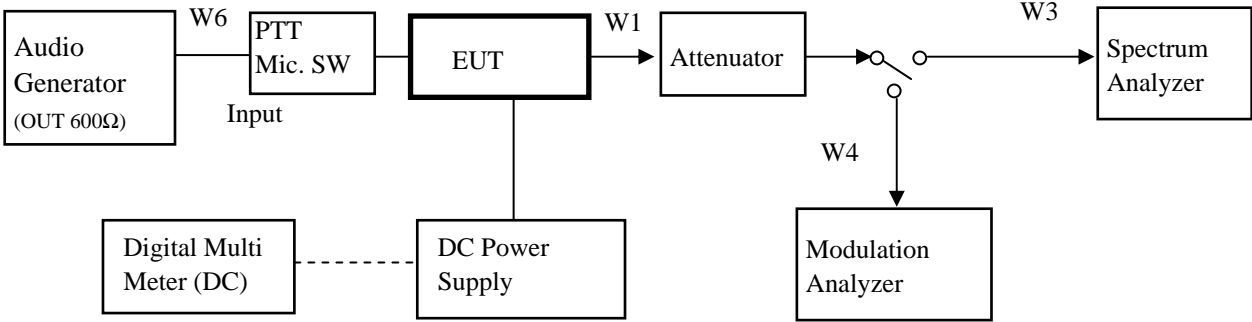

Note: Configuration of other Modulation(4Level FSK) test is composed without the Audio Generator.

<CW ID Modulation Case>

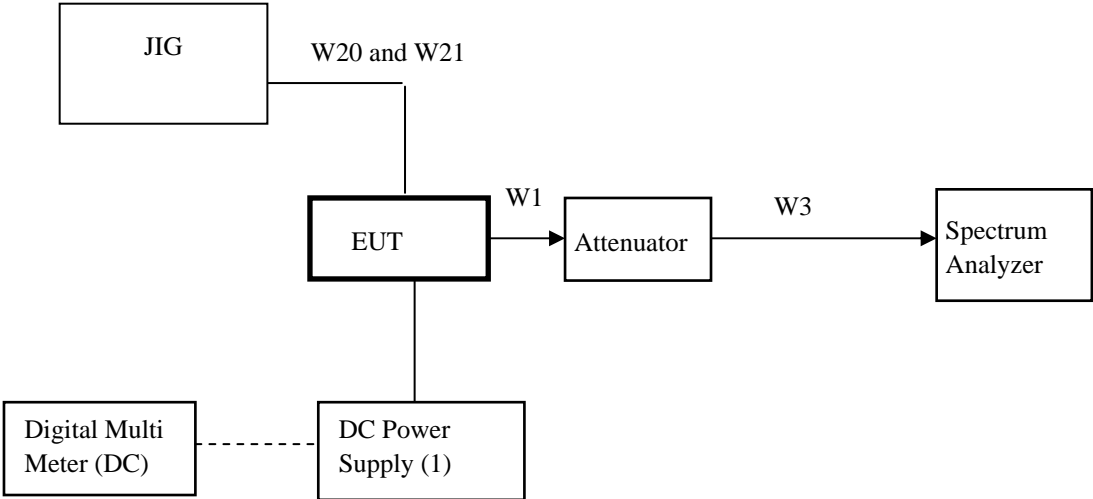

→ : RF Output

Test Results

Test date	Apr. 27, 2010 to Apr. 28, 2010
Location	Tochigi No.2 Test Site
temperature	20.0 to 26.0 [degree C]
Humidity Variation	45 to 52 [%]
Atmospheric Pressure	99.8 to 100.2 [kPa]
Test Engineer	Atsuyuki Morishima

Test was carried out for all the frequency band of section 10.1
 State the worst case (below).

State : High Power / Authorized Bandwidth 20 kHz/ 450.05 MHz

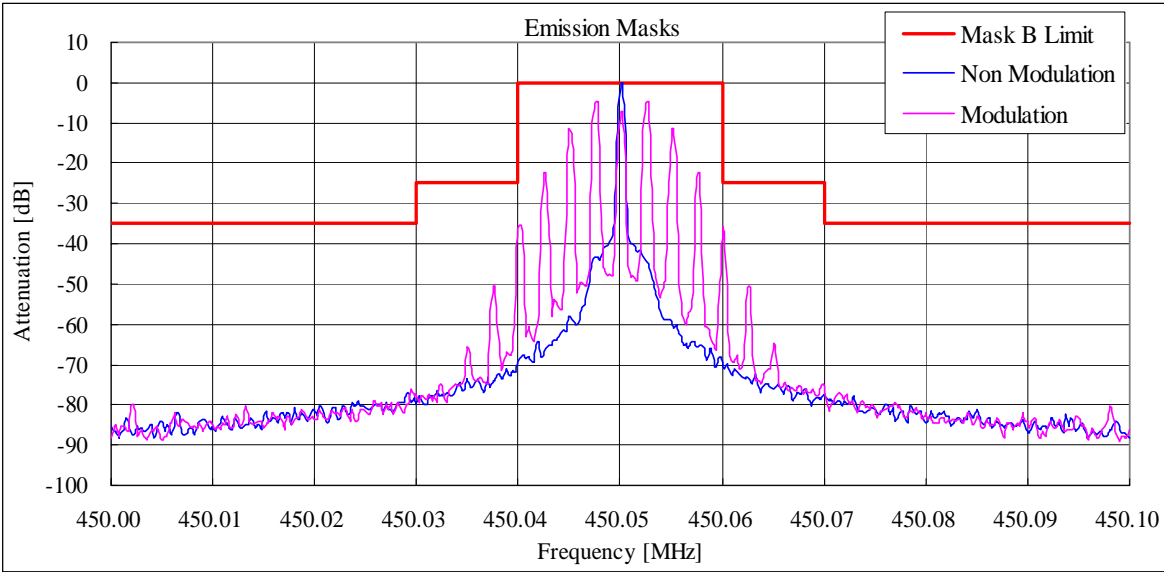

State : High Power / Authorized Bandwidth 11.25 kHz/ 511.95 MHz

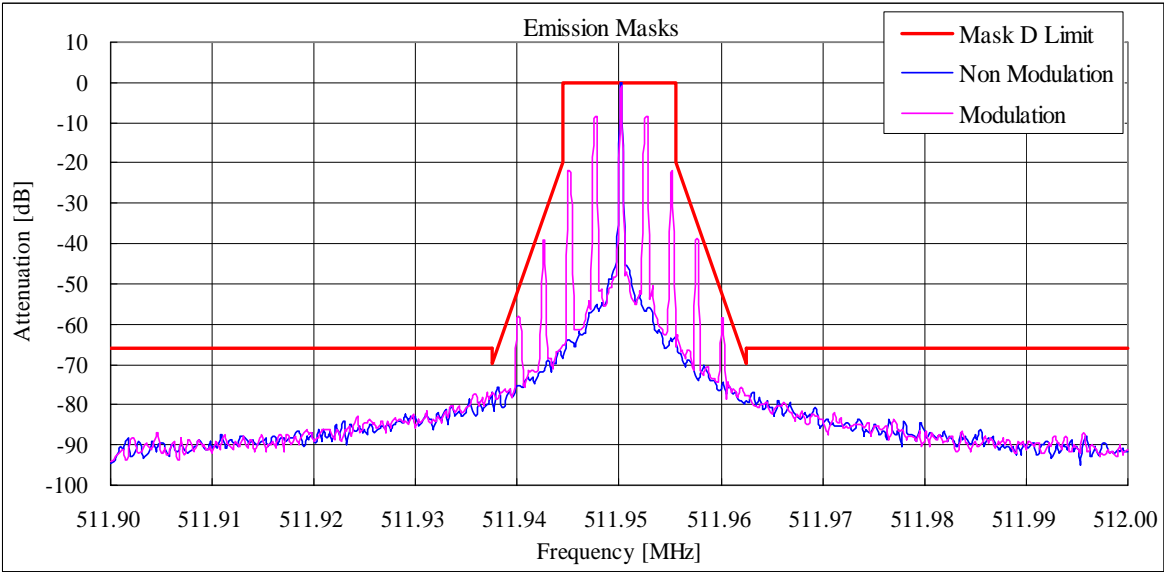

State : High Power / Authorized Bandwidth 11.25 kHz:4Level FSK / 450.05 MHz

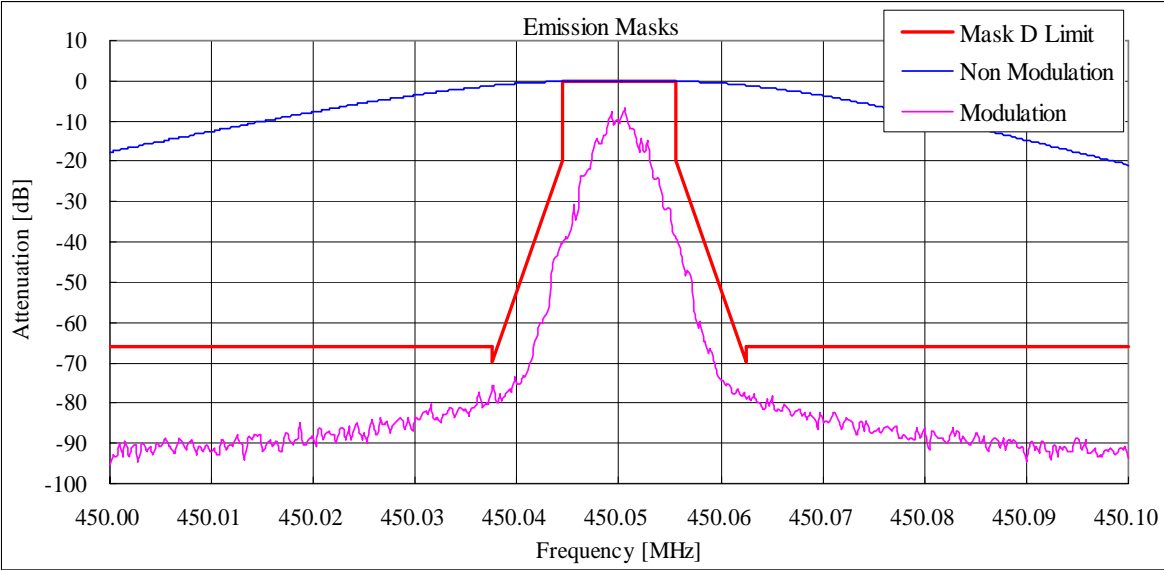

State : High Power / Authorized Bandwidth 6 kHz:4Level FSK / 511.95 MHz

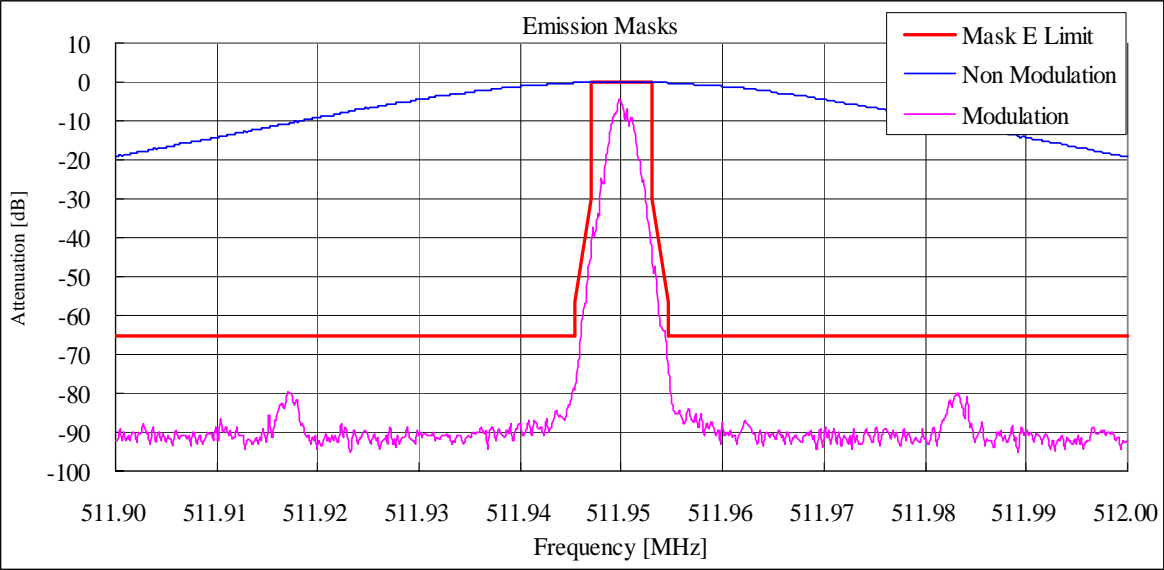

State : High Power / Authorized Bandwidth 6 kHz: CW ID / 511.95 MHz(FCC)

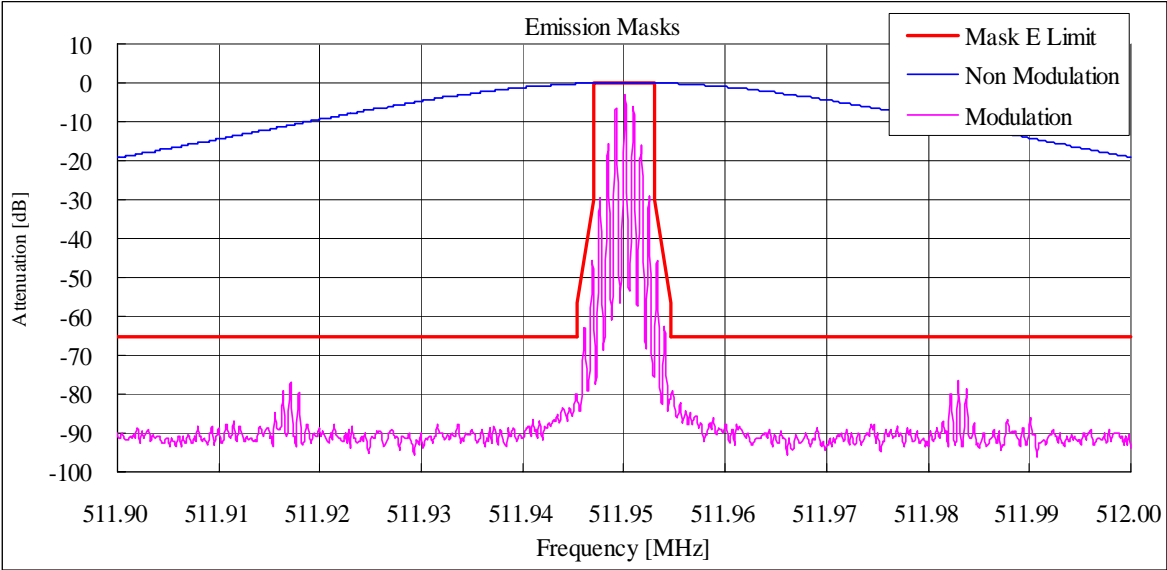

State : Low Power / Authorized Bandwidth 20 kHz:FM / 450.05 MHz

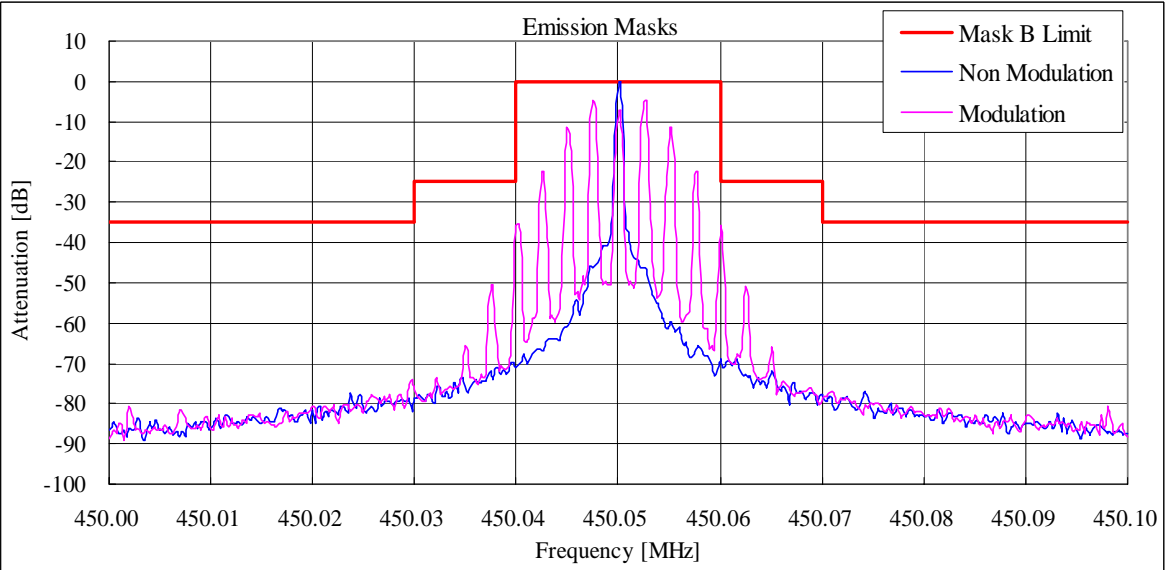

State : Low Power / Authorized Bandwidth 11.25 kHz:FM / 511.95 MHz

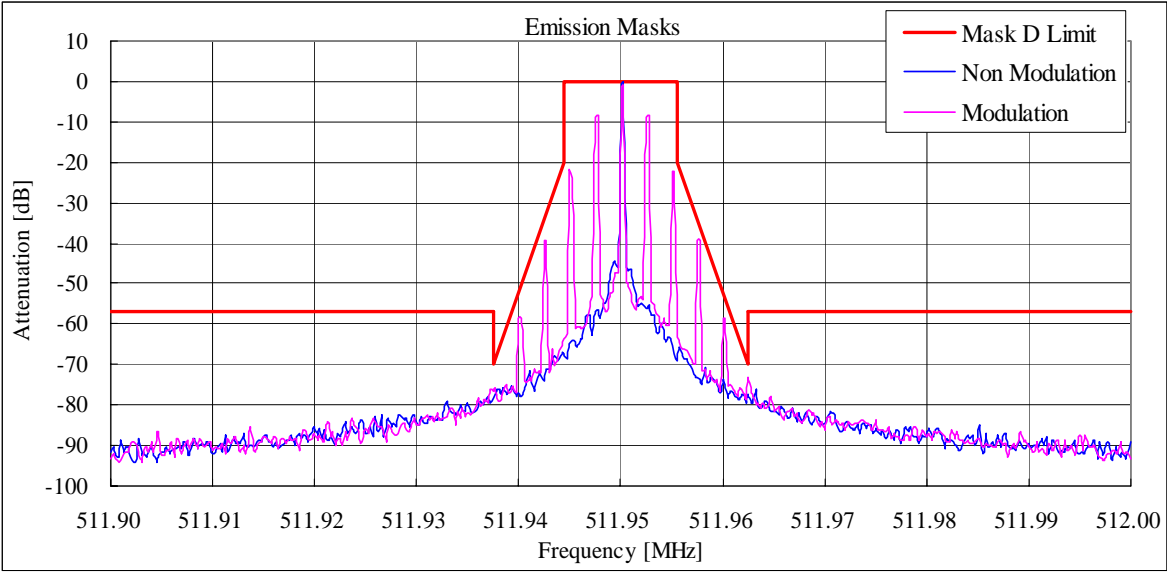

State : Low Power / Authorized Bandwidth 11.25 kHz:4Level FSK / 450.05 MHz

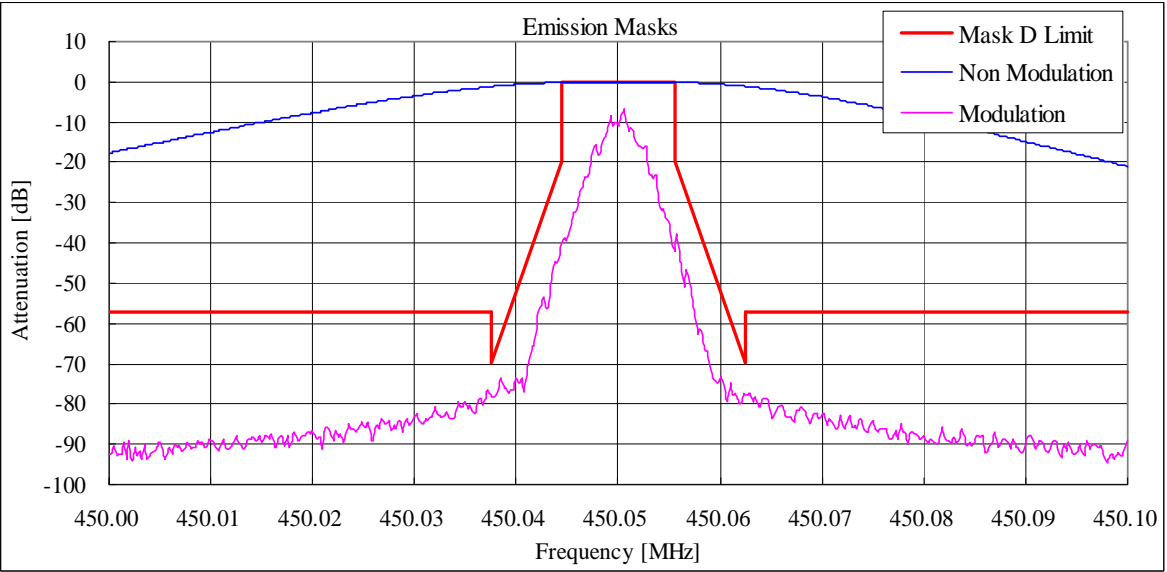

State : Low Power / Authorized Bandwidth 6 kHz:4Level FSK / 511.95 MHz(FCC/RSS)

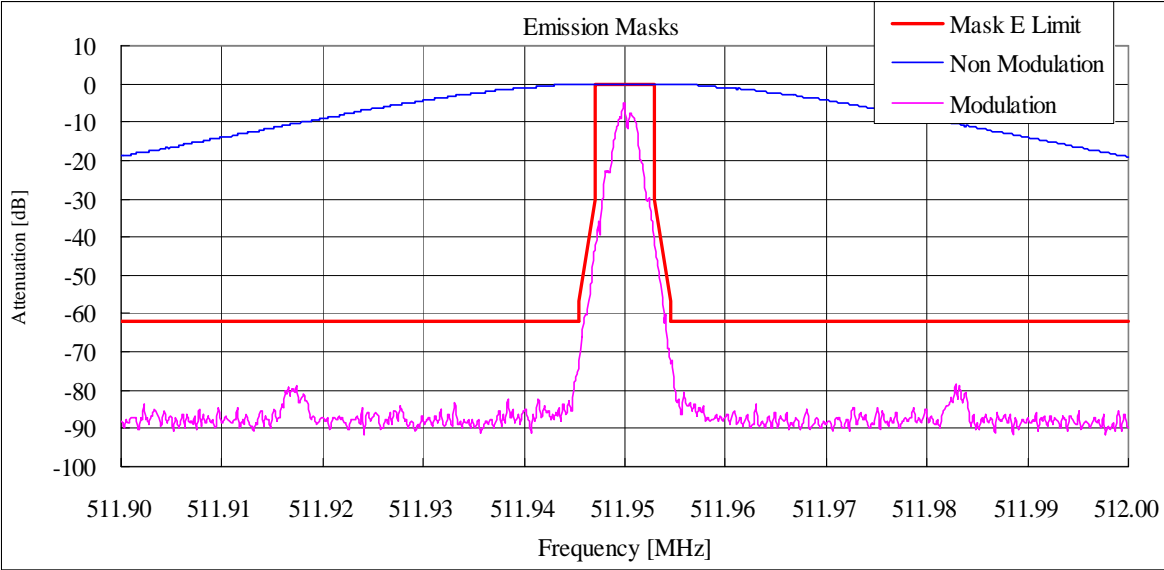

State : Low Power / Authorized Bandwidth 6 kHz:CW ID / 511.95 MHz

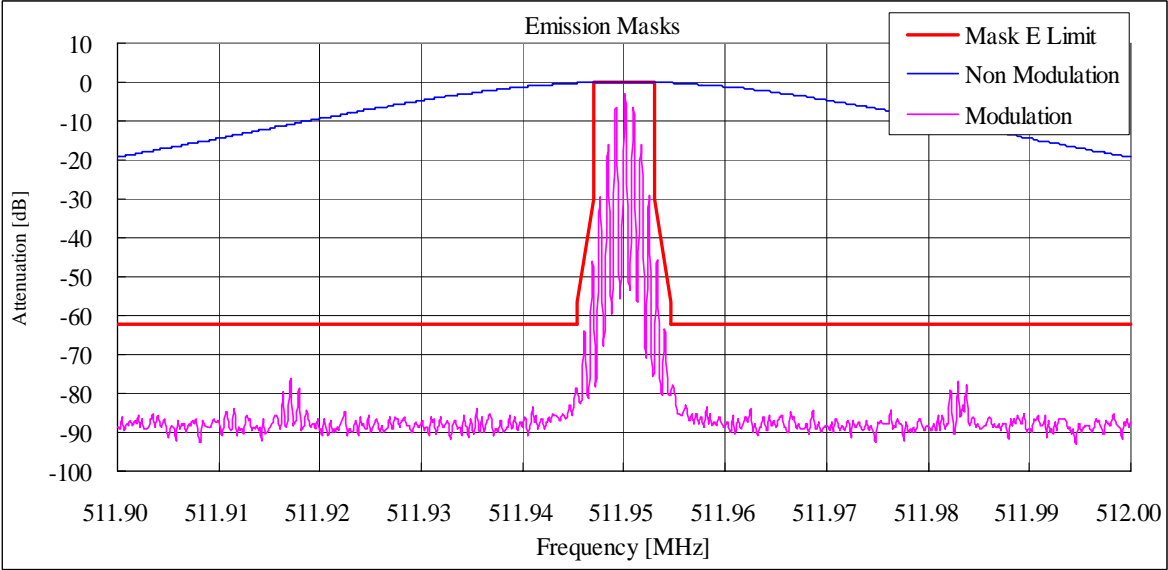

10.5 Transient Frequency Behavior

REGULATIONS	: FCC Part 90 Section 214
TEST METHOD/GUIDE	: ANSI/TIA-603-C Section 2.2.19.3

Test Procedure

- 1 The EUT and test equipment were set up as shown on the following page.
- 2 The transmitter was turned on.
- 3 The transmitter carrier level was measured at the output of the combiner .
- 4 The transmitter was turned off.
- 5 An RF signal generator (1) modulated with a 1 kHz tone at either 25 kHz or 12.5 kHz or 6.25 kHz deviation, and set to the same frequency as the assigned transmitter frequency, (2) was adjusted to a level -30 dB below the level recorded in Procedure 3, as measured at the output of the combiner.
 This level was then fixed for the remainder of the test and is recorded at step h.
- 6 The oscilloscope was setup using TIA-603C steps j and k as a guide, however 1000 Hz tone was adjusted at +- 2.5 /div vertically centered on the display.
- 7 The transmitter was turned on, and the level of the carrier at the output of the combiner was recorded as step l.
- 8 The carrier on-time as referenced in TIA-603-C steps m, n, and o was captured and plotted.
- 9 The carrier off-time as referenced in TIA-603-C steps p, q, r, and s was captured and plotted.

No.	Equipment	Manufacture	Model No.	Serial No.	Cal Date	Cal Exp.
1	Signal Generator	Rohde&Schwarz	SMT06	100684	Dec. 24, 09	Dec. 31, 10
2	Oscilloscope	Lecroy	9360	1408	Apr. 15, 10	Apr. 30, 11
3	Power Meter	Hewlett Packard	E4418B	GB38410265	May 26, 09	May 31, 10
4	Power Sensor	Hewlett Packard	8482A	US37292237	May 26, 09	May 31, 10
5	Attenuator (20dB)	Aeroflex/Wenshel	66-20-34	BY4537	Mar. 12, 10	Mar. 31, 11
6	Attenuator (30dB)	Weinschel	WA-29-30-34	8923	May 15, 09	May 31, 10
7	Modulation Analyzer	Hewlett Packard	8901B	3403A04852	Jul. 08, 09	Jul. 31, 10
8	Combiner(1)	Anritsu	Z-164A	M89549	Nov. 06, 09	Nov. 30, 10
9	Combiner(2)	Anritsu	Z-164A	M89249	Nov. 06, 09	Nov. 30, 10
10	Attenuator (3dB)	TME	CFA-20NPJ-3	679701	May 15, 09	May 31, 10
11	Digital Multi Meter	FLUKE	8846A	9642018	Jul. 06, 09	Jul. 31, 10
12	DC Power Supply	Daiichi denpa kogyo	GZV4000	90290932	None	None

Measuring Cables

No.	Cable	Manufacture	Model No.	Serial No.	Cal Date	Cal Exp.
W1	Coaxial Cable	Suhner	SUCOFLEX104	KSR00091	May 15, 09	May 31, 10
W4	Coaxial Cable	Suhner	SUCOFLEX104	KSR00217	Sep. 03, 09	Sep. 30, 10
W5	Coaxial Cable	Pacific custom	RG-58 C/U	KSR00096	Nov. 09, 09	Nov. 30, 10
W9	Coaxial Cable	Pacific custom	RG-58 C/U	KSR00094	Nov. 09, 09	Nov. 30, 10
W10	Coaxial Cable	Pacific custom	RG-58 C/U	KSR00097	Nov. 09, 09	Nov. 30, 10
W12	Coaxial Cable	Suhner	SUCOFLEX104	KSR00042	Mar. 12, 10	Mar. 31, 11

Measuring Equipment Configuration

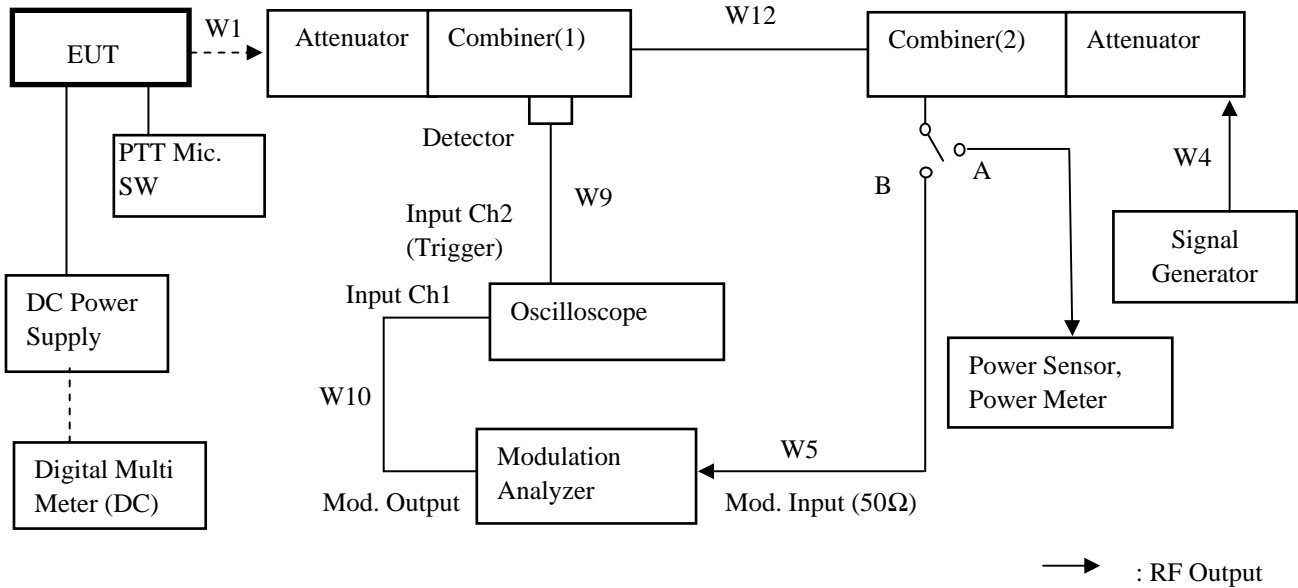

Test Results

Test date	May. 07, 2010
Location	Tochigi No.2 Test Site
temperature	23 to 24 [degree C]
Humidity Variation	41 to 42 [%]
Atmospheric Pressure	98.3 to 98.4 [kPa]
Test Engineer	Atsuyuki Morishima

Test was carried out for all the frequency band of section 10.1
 State the worst case (below).

State : High Power / Authorized Bandwidth 20 kHz / 511.95 MHz/ PTT:OFF -ON

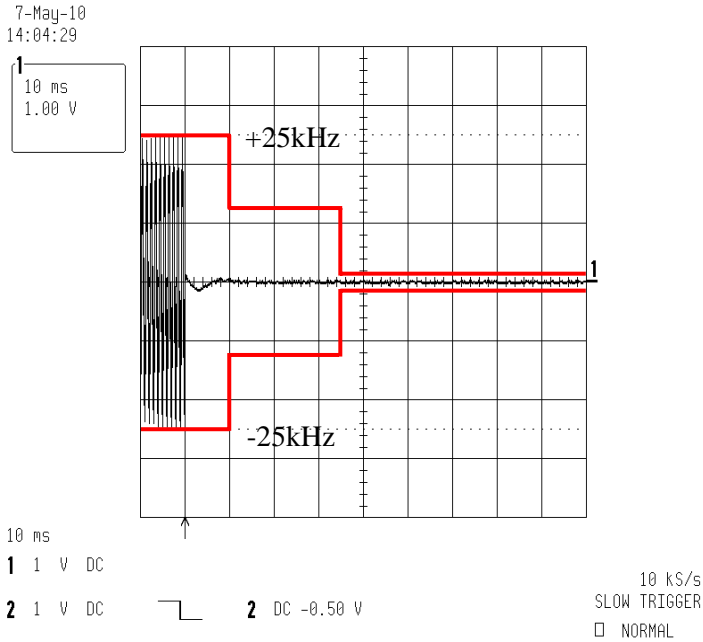

State : High Power / Authorized Bandwidth 20 kHz / 511.95 MHz/ PTT:ON -OFF

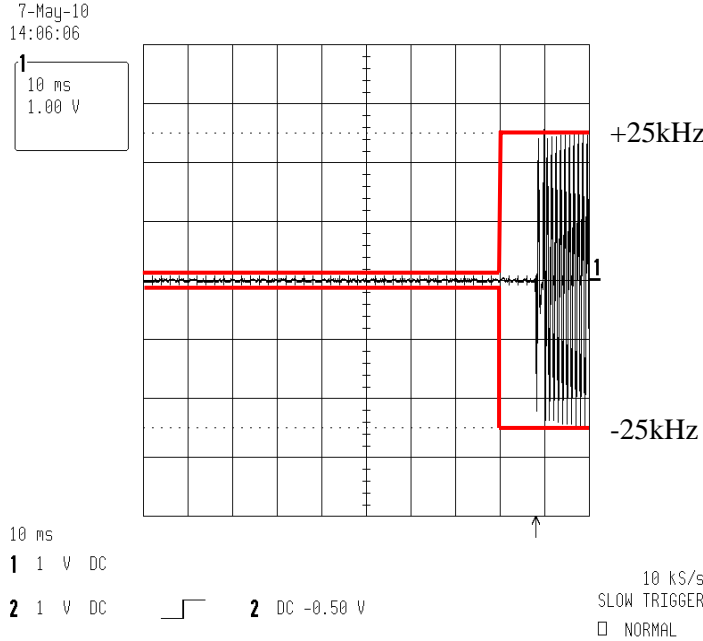

State : High Power / Authorized Bandwidth 11.25 kHz / 511.95 MHz/ PTT:OFF -ON

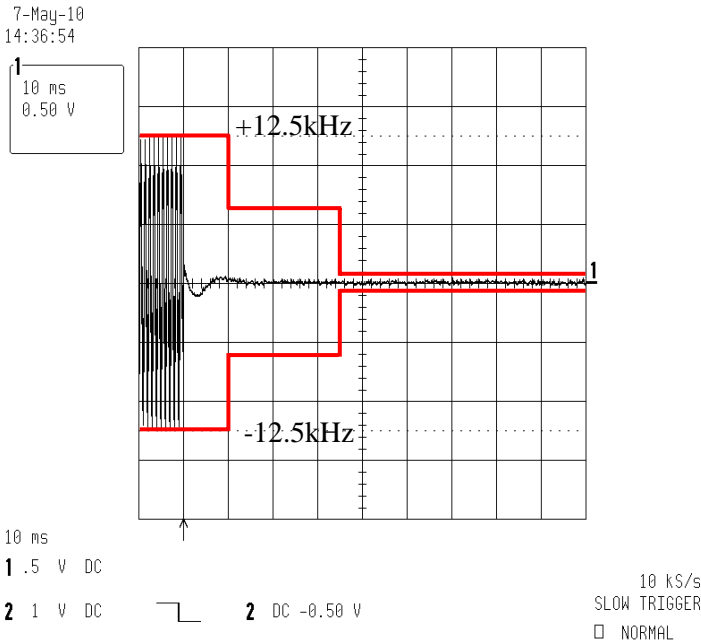

State : High Power / Authorized Bandwidth 11.25 kHz / 511.95 MHz/ PTT:ON -OFF

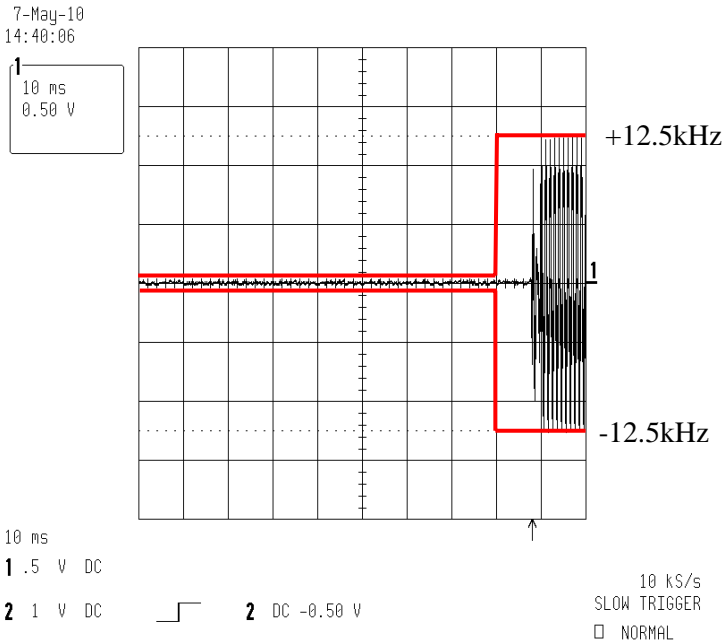

State : High Power / Authorized Bandwidth 11.25 kHz / 4 Lvel FSK / 511.95 MHz/ PTT:OFF -ON

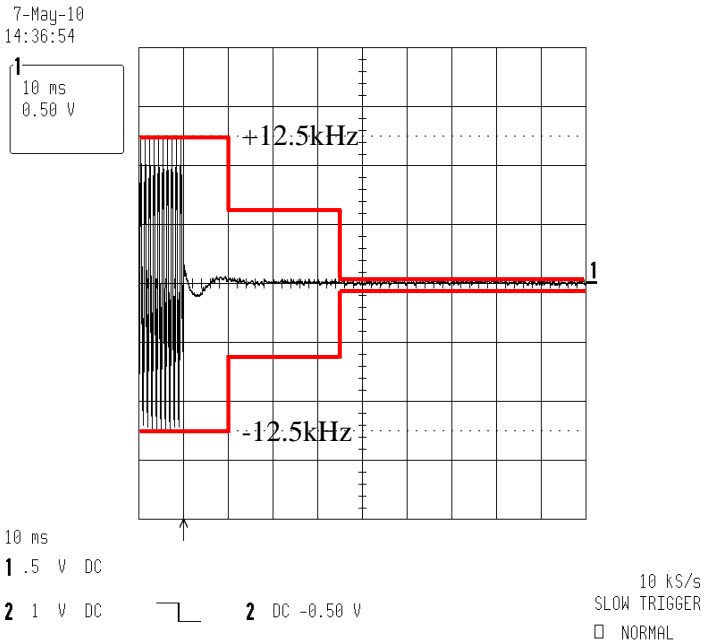

State : High Power / Authorized Bandwidth 11.25 kHz / 4 Lvel FSK / 511.95 MHz/ PTT:ON -OFF

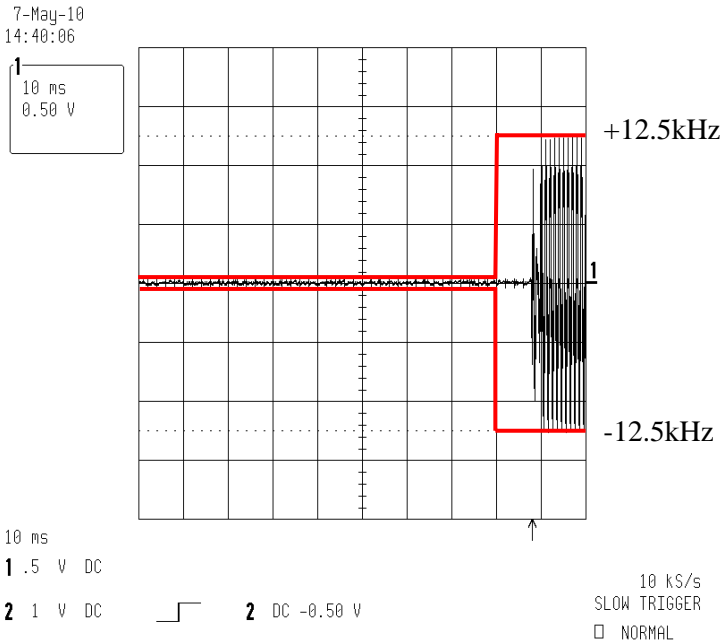

State : High Power / Authorized Bandwidth 6 kHz / 4 Lvel FSK / 511.95 MHz/ PTT:OFF -ON

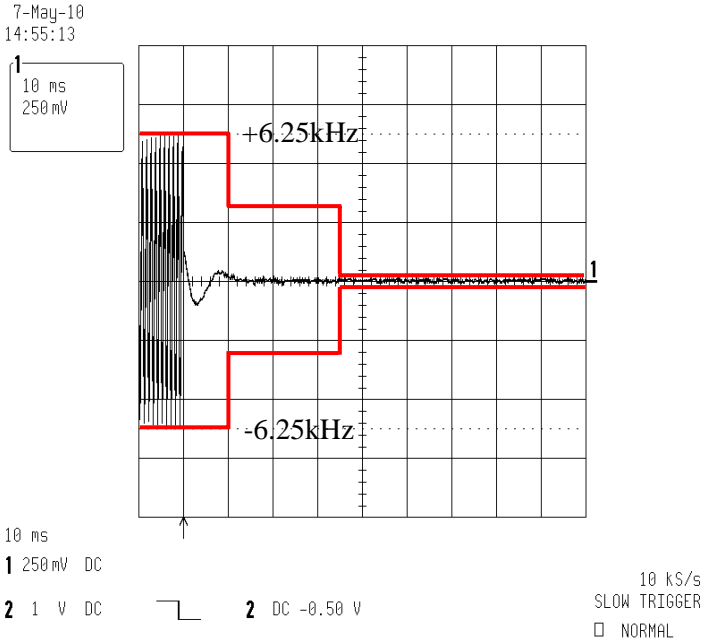

State : High Power / Authorized Bandwidth 6 kHz / 4 Lvel FSK / 511.95 MHz/ PTT:ON -OFF

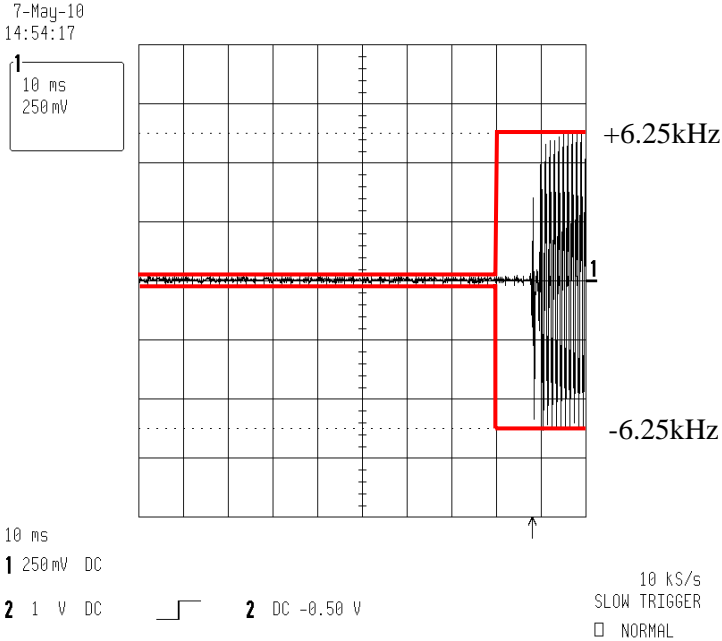

State : High Power / Authorized Bandwidth 6 kHz / CW ID / 511.95 MHz/ PTT:OFF -ON

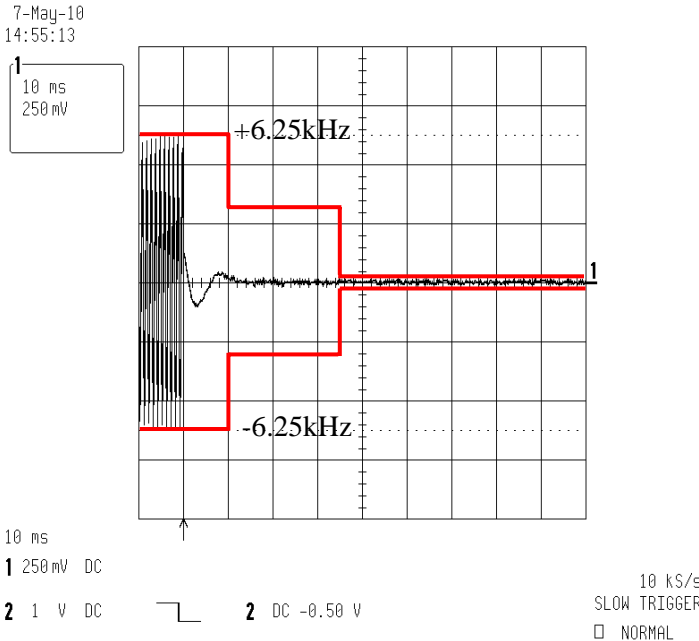

State : High Power / Authorized Bandwidth 6 kHz / CW ID / 511.95 MHz/ PTT:ON -OFF

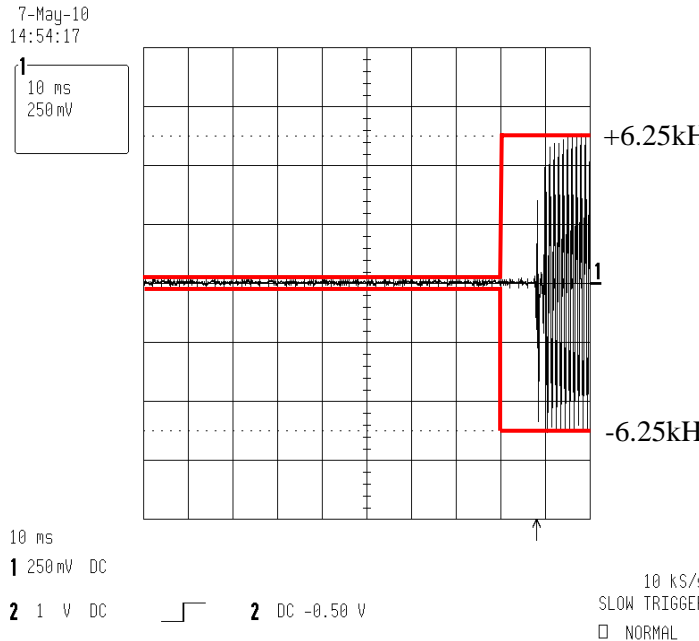

10.6 Audio Frequency Response / Audio Low Pass Filter (Voice Input)

REGULATIONS	: FCC Part 2 Section 1047 (a)
TEST METHOD/GUIDE	: ANSI/TIA-603-C Section 2.2.6.2.2, 3.2.6.2

Test Procedure

- 1 The EUT and test equipment were set up as shown on the following page.
- 2 Adjust the Modulation Analyzer for the following setting:
 - a) High-pass filter : 50 Hz
 - b) Low-pass filter : 15 kHz
 - c) Detector : positive peak
 - d) Function : FM
- 3 The audio signal input was adjusted to obtain 20 % modulation at 1 kHz, and this point was taken as the 0 dB reference level.
- 4 With input levels held constant and below limiting at all frequencies, the audio signal generator was varied from 300 Hz to 5 kHz.
- 5 The response in dB relative to 1 kHz was then measured, using the Modulation Analyzer.

Measuring Equipments

No.	Equipment	Manufacture	Model No.	Serial No.	Cal Date	Cal Exp.
1	Audio Generator	Anritsu	MG443B	M70150	Apr. 15, 10	Apr. 30, 11
2	Audio Analyzer	Hewlett Packard	8903B	2818A04372	Apr. 09, 10	Apr. 30, 11
3	Attenuator (20dB)	Aeroflex/Wenschel	66-20-34	BY4537	Mar. 12, 10	Mar. 31, 11
4	Attenuator (30dB)	Weinschel	WA-29-30-34	8923	May 15, 09	May 31, 10
5	Modulation Analyzer	Hewlett Packard	8901B	3403A04852	Jul. 08, 09	Jul. 31, 10
6	Digital Multi Meter	FLUKE	8846A	9642018	Jul. 06, 09	Jul. 31, 10
7	DC Power Supply	Daiichi denpa kogyo	GZV4000	90290932	None	None

Measuring Cables

No.	Cable	Manufacture	Model No.	Serial No.	Cal Date	Cal Exp.
W1	Coaxial Cable	Suhner	SUCOFLEX104	KSR00091	May 15, 09	May 31, 10
W4	Coaxial Cable	Pacific custom	RG-58 C/U	KSR00096	Nov. 09, 09	Nov. 30, 10
W6	Balance Cable	Nicoon	3D-2V	KSR00092	Oct. 26, 09	Oct. 31, 10
W9	Coaxial Cable	Pacific custom	RG-58 C/U	KSR00097	Nov. 09, 09	Nov. 30, 10

Measuring Equipment Configuration

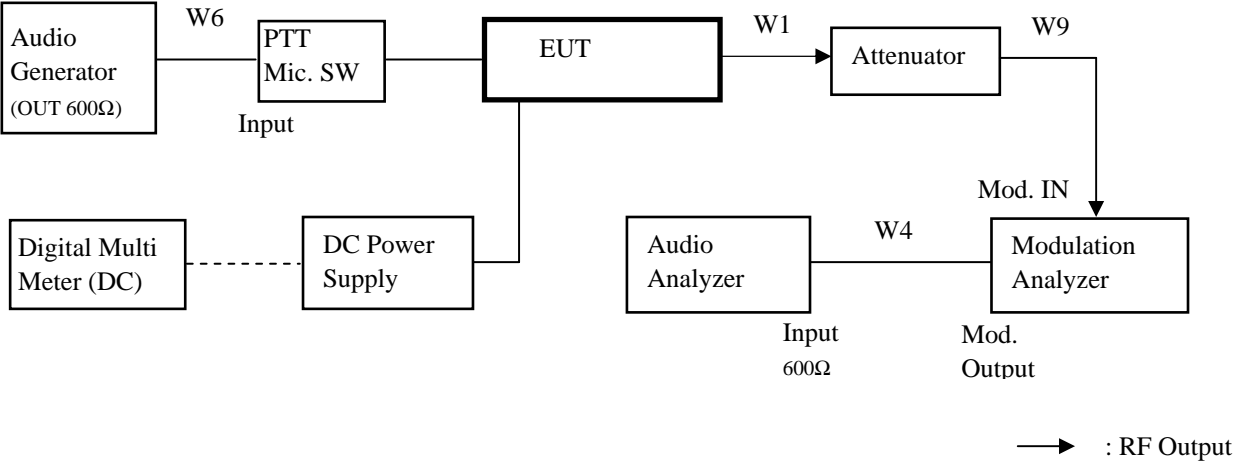

Test Results

Test date	Apr. 26, 2010
Location	Tochigi No.2 Test Site
temperature	24.0 to 25.0 [degree C]
Humidity Variation	45 to 46 [%]
Atmospheric Pressure	100.2 to 100.3 [kPa]
Test Engineer	Atsuyuki Morishima

Test was carried out for all the frequency band of section 10.1
 State the worst case (below).

State : High Power / Authorized Bandwidth 20 kHz / 511.95 MHz

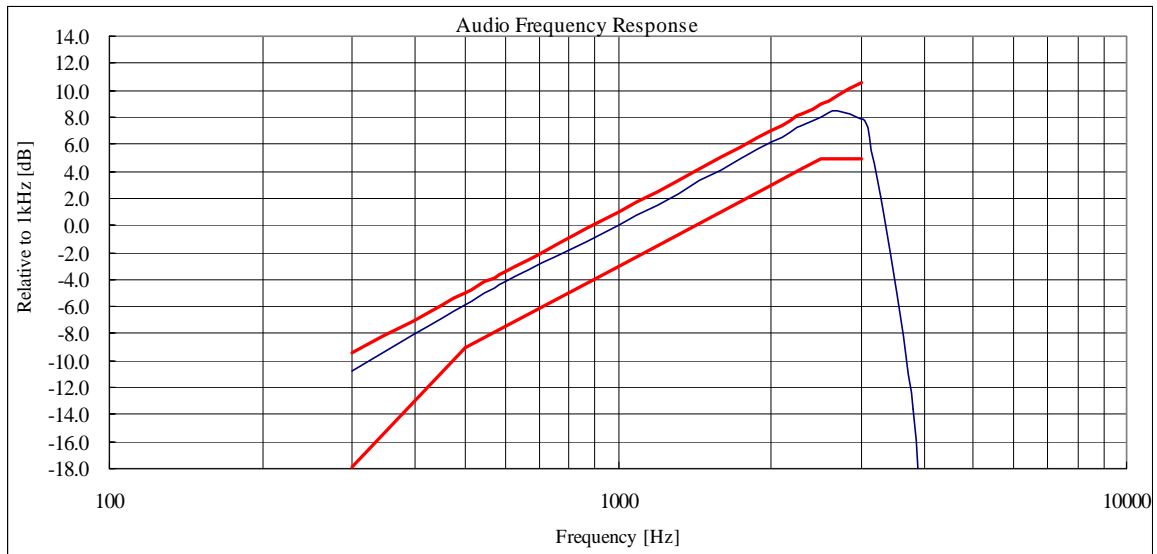

State : High Power / Authorized Bandwidth 11.25 kHz / 481.05 MHz

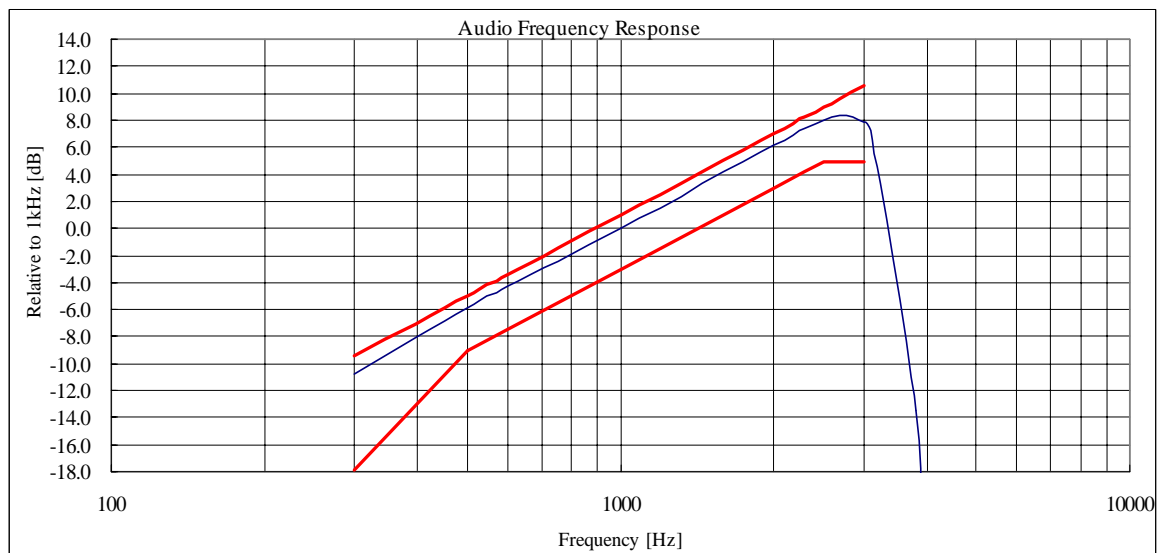

Note:

Audio Filter of the above result is substituted with the same structure as Audio Frequency Response.
 On the transmission condition below 3kHz, Transceiver shows pre-emphasis condition of transmission function.

On the transmission condition above 3kHz, Transceiver shows Audio Low Pass Filter.

10.7 Modulation Limiting

REGULATIONS	: FCC Part 2 Section 1047 (b)
TEST METHOD/GUIDE	: ANSI/TIA-603-C Section 2.2.3.2, 1.3.4.4

Test Procedure

- 1 The EUT and test equipment were set up as shown on the following page.
- 2 Adjust the Modulation Analyzer for the following setting:
 - a) High-pass filter : off
 - b) Low-pass filter : 15 kHz
 - c) Detector : positive peak
 - d) Function : FM
- 3 Apply a 1kHz modulation signal to the transmitter from the audio generator, and adjust the level to obtain 60% of full rated system deviation.
- 4 Measure the modulation frequency that was showed on the Modulation Analyzer when the output levels of the Audio Generator were changed from -20 dB to +50 dB by 10 dB.
- 5 Set the output frequencies of the Audio Generator 300 Hz and 3 kHz, and repeat test procedure 4.
- 6 Set the Detector of the Modulation Analyzer Negative Peak.
- 7 Repeat test procedure 4 and 5.

Measuring Equipments

No.	Equipment	Manufacture	Model No.	Serial No.	Cal Date	Cal Exp.
1	Audio Generator	Anritsu	MG443B	M70150	Apr. 15, 10	Apr. 30, 11
2	Attenuator (20dB)	Aeroflex/Wenshel	66-20-34	BY4537	Mar. 12, 10	Mar. 31, 11
3	Attenuator (30dB)	Weinschel	WA-29-30-34	8923	May 15, 09	May 31, 10
4	Modulation Analyzer	Hewlett Packard	8901B	3403A04852	Jul. 08, 09	Jul. 31, 10
5	Digital Multi Meter	FLUKE	8846A	9642018	Jul. 06, 09	Jul. 31, 10
6	DC Power Supply	Daichi denpa kogyo	GZV4000	90290932	None	None

Measuring Cables

No.	Cable	Manufacture	Model No.	Serial No.	Cal Date	Cal Exp.
W1	Coaxial Cable	Suhner	SUCOFLEX104	KSR00091	May 15, 09	May 31, 10
W4	Coaxial Cable	Pacific custom	RG-58 C/U	KSR00096	Nov. 09, 09	Nov. 30, 10
W6	Balance Cable	Nicoon	3D-2V	KSR00092	Oct. 26, 09	Oct. 31, 10

Measuring Equipment Configuration

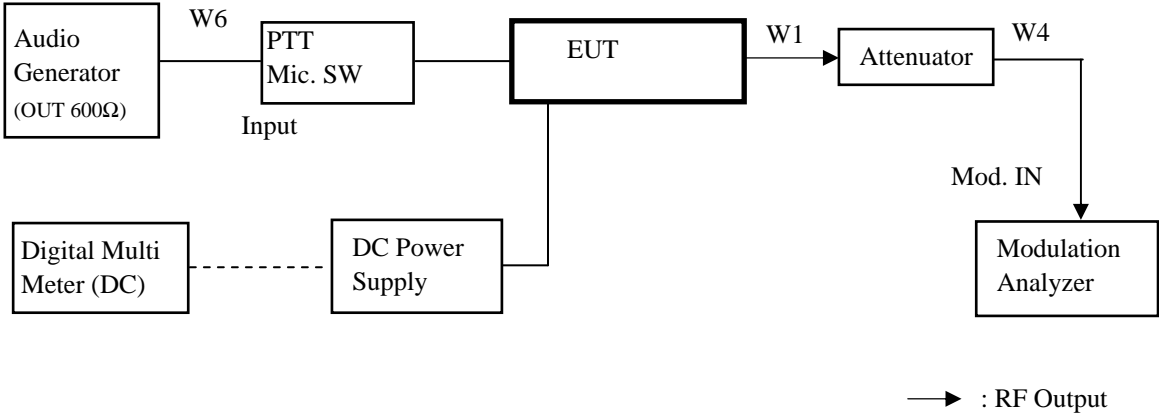

Test Results

Test date	Apr. 26, 2010		
Location	Tochigi No.2 Test Site		
temperature	23.0 to 24.0	[degree C]	
Humidity Variation	45 to 47	[%]	
Atmospheric Pressure	100.1 to 100.3	[kPa]	
Test Engineer	Atsuyuki Morishima		

Test was carried out for all the frequency band of section 10.1
 State the worst case (below).

State : High Power / Authorized Bandwidth 20 kHz / 511.95 MHz

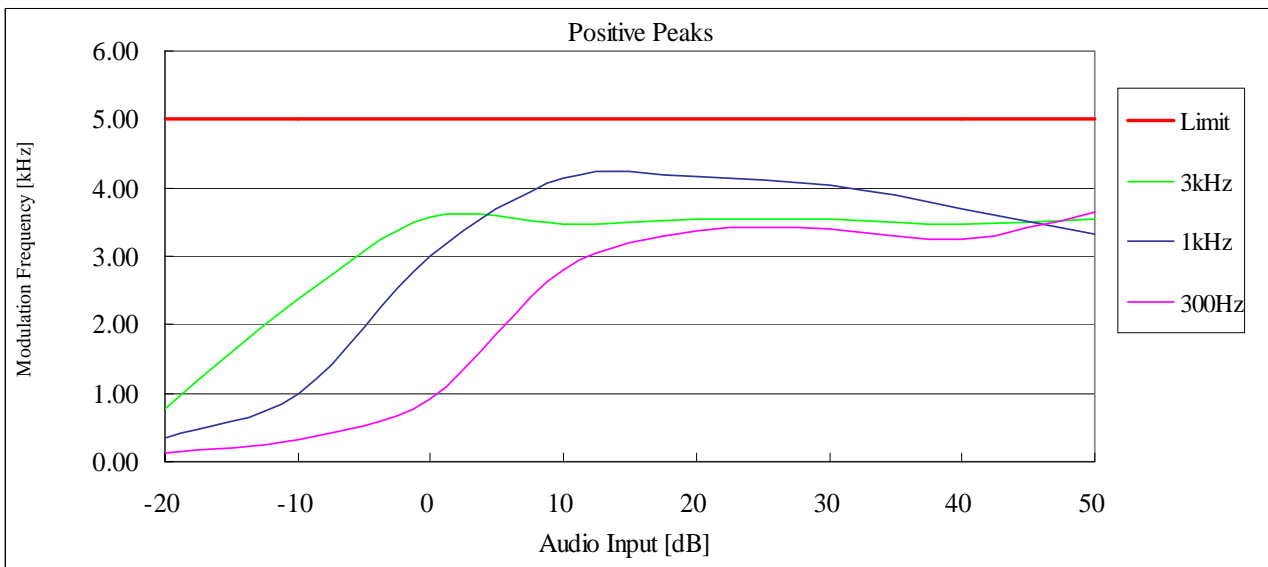

State : High Power / Authorized Bandwidth 20 kHz / 511.95 MHz

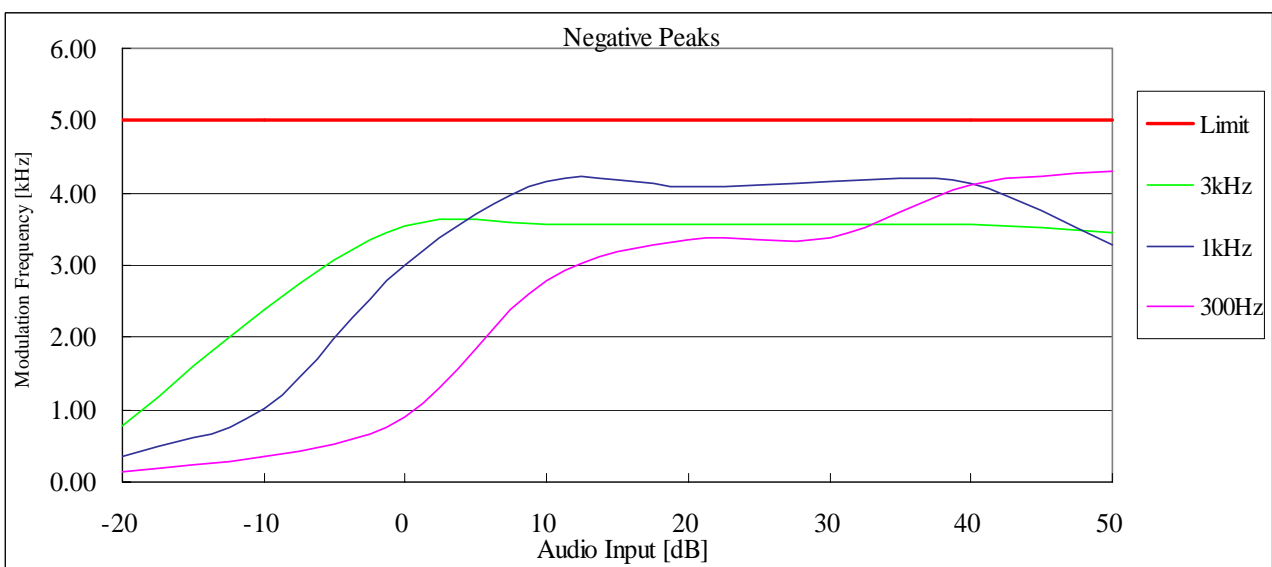

State : High Power / Authorized Bandwidth 11.25 kHz / 450.05 MHz

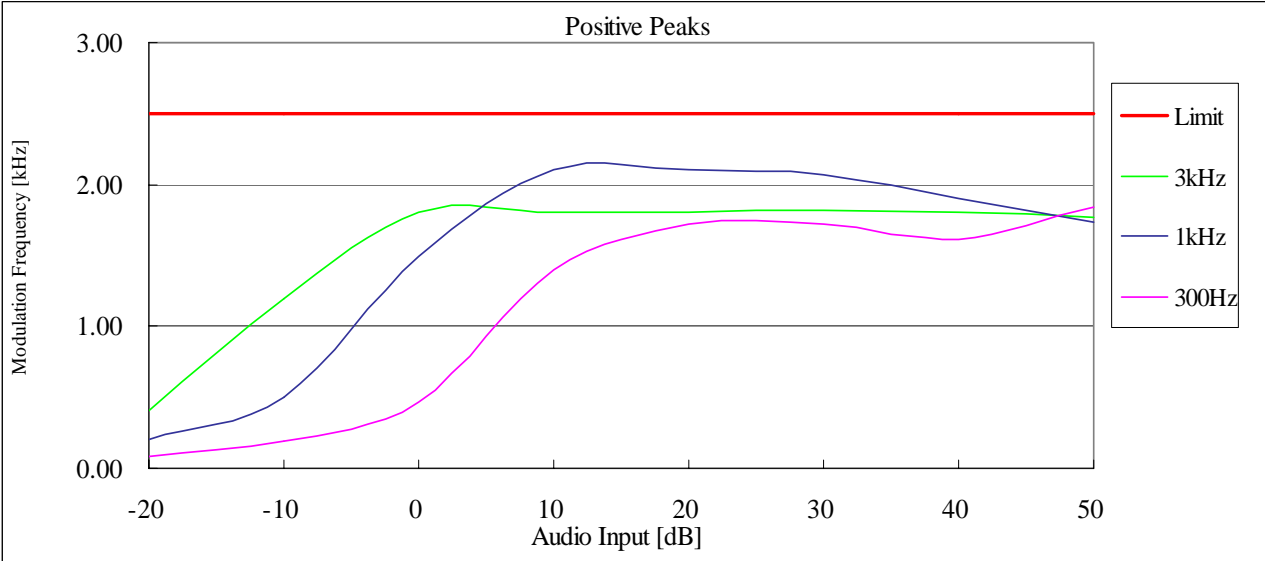

State : High Power / Authorized Bandwidth 11.25 kHz / 450.05 MHz

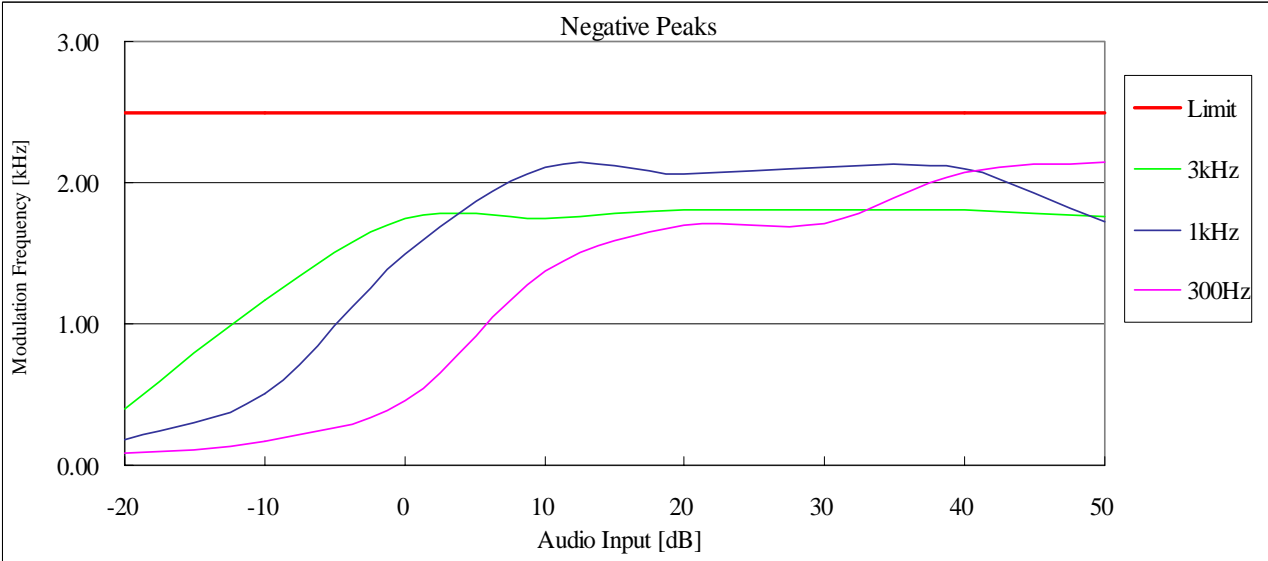

10.8 Frequency Stability (Temperature Variation)

REGULATIONS	: FCC Part 2 Section 1055 (a) (1), Part 90 Section 213(a)
TEST METHOD/GUIDE	: ANSI/TIA-603-C Section 2.2.2.2

Test Procedure

- 1 The EUT and test equipment were set up as shown on the following page.
- 2 Set the temperature -30 degrees C.
- 3 Leave the EUT for 1 hour after it became the temperature that was set up.
- 4 Make the EUT the transmitting state.
One minute later, measure the output frequency.
- 5 Make the EUT the receiving state.
- 6 Set the temperature 50 degrees C by 10 degrees C.
And repeat test procedure 3 to 5.

Measuring Equipments

No.	Equipment	Manufacture	Model No.	Serial No.	Cal Date	Cal Exp.
1	Attenuator (30dB)	Weinschel	WA-29-30-34	8923	May 15, 09	May 31, 10
2	Attenuator (20dB)	Aeroflex/Wenshel	66-20-34	BY4537	May. 15, 09	May. 31, 10
3	Modulation Analyzer	Hewlett Packard	8901B	3403A04852	Jul. 08, 09	Jul. 31, 10
4	Digital Multi Meter	FLUKE	8846A	9642018	Jul. 06, 09	Jul. 31, 10
5	DC Power Supply	Daiichi denpa kogyo	GZV4000	90290932	None	None
6	DC Power Supply	Micky	10A	None	None	None
7	Temperature Chamber	Tabai	PL-3F	5103661	None	None
8	Temperature Meter	Sato	PC-5000TRH-II	A11999972	Apr. 15, 10	Apr. 30, 11
9	GPS Reciever	Hewlett Packard	HP Z3801A	3542A02414	None	None

Measuring Cables

No.	Cable	Manufacture	Model No.	Serial No.	Cal Date	Cal Exp.
W1	Coaxial Cable	Suhner	SUCOFLEX104	KSR00091	May 15, 09	May 31, 10
W3	Coaxial Cable	Suhner	SUCOFLEX104	KSR00042	Mar. 12, 10	Mar. 31, 11

Measuring Equipment Configuration

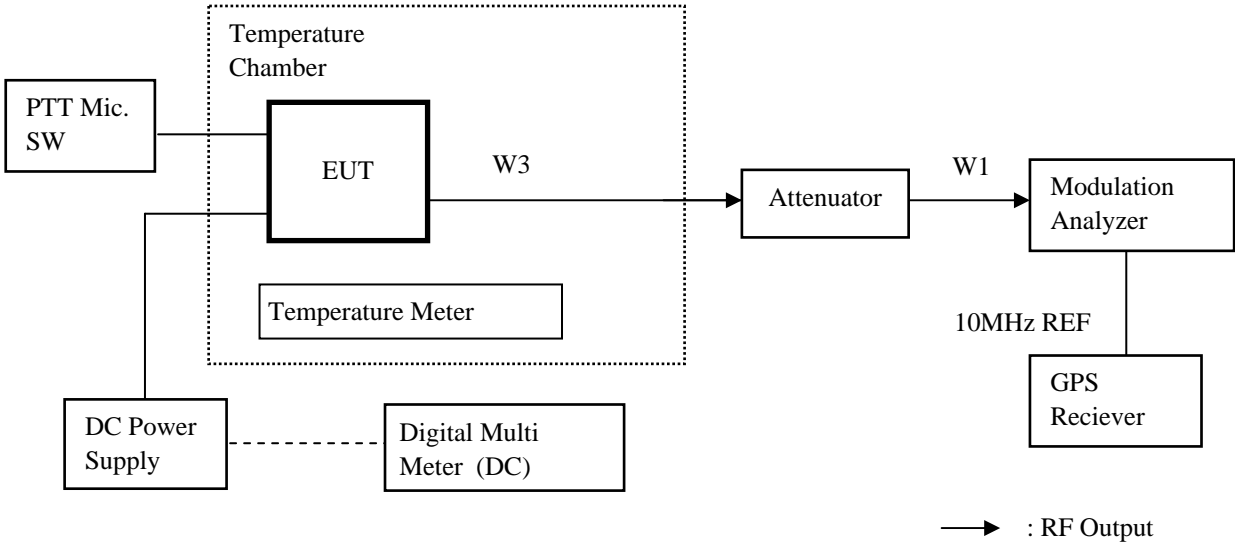

Test Results

Test date	May. 19, 2010 to May.20,2010
Location	Kashima No.1 Test Site
Test Engineer	Atsuyuki Morishima

Test was carried out for all the frequency band of section 10.1
 State the worst case (below).

State : High Power / Authorized Bandwidth 20 kHz / 511.95 MHz

Reference Frequency: 511.950000 MHz

No.	Temperature (Degree C)	Frequency (MHz)	Stability (ppm)	Limit (+/- ppm)	Min. Margin (ppm)
1	-30	511.950030	0.06	0.5	0.44
2	-20	511.949980	-0.04	0.5	0.46
3	-10	511.950010	0.02	0.5	0.48
4	0	511.949990	-0.02	0.5	0.48
5	10	511.950020	0.04	0.5	0.46
6	20	511.949990	-0.02	0.5	0.48
7	30	511.949940	-0.12	0.5	0.38
8	40	511.949900	-0.20	0.5	0.30
9	50	511.949930	-0.14	0.5	0.36

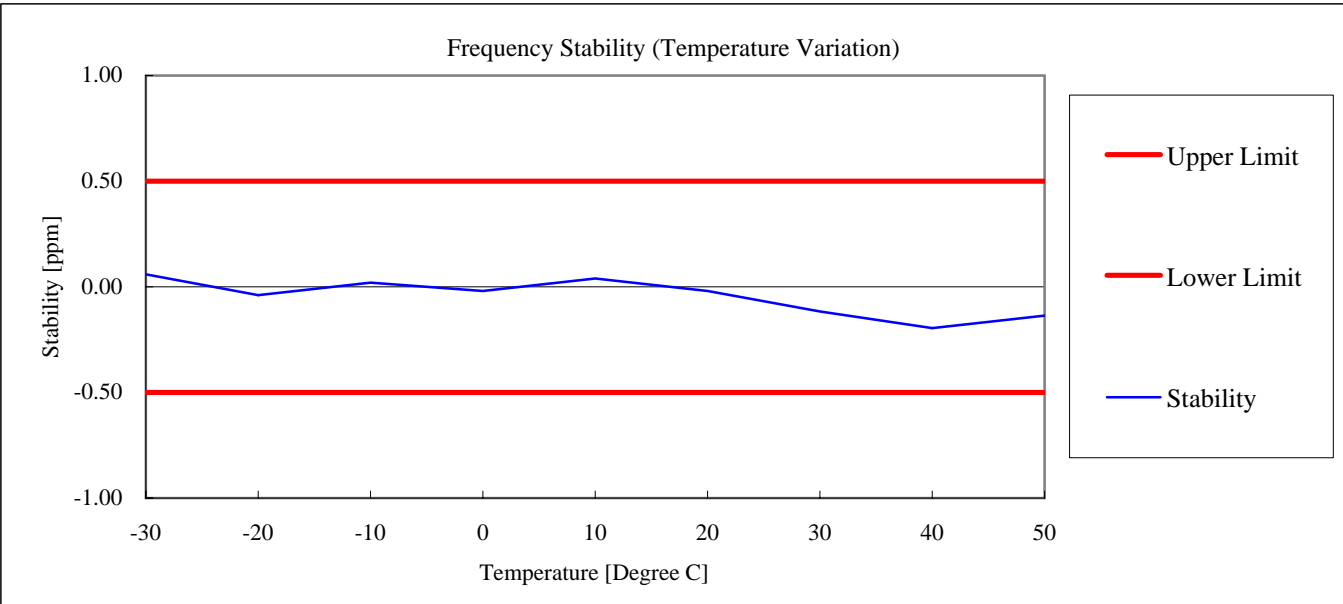

10.9 Frequency Stability (Voltage Variation)

REGULATIONS	: FCC Part 2 Section 1055 (d) (1), Part 90 Section 213(a)
TEST METHOD/GUIDE	: ANSI/TIA-603-C Section 2.2.2.2

Test Procedure

- 1 The EUT and test equipment were set up as shown on the following page.
- 2 The power supply voltage to the EUT was varied from 85 % to 115 % of the nominal value measured at the input to the EUT.

Measuring Equipments

No.	Equipment	Manufacture	Model No.	Serial No.	Cal Date	Cal Exp.
1	Attenuator (30dB)	Weinschel	WA-29-30-34	8923	May 15, 09	May 31, 10
2	Attenuator (20dB)	Aeroflex/Wenshel	66-20-34	BY4537	May. 15, 09	May. 31, 10
3	Modulation Analyzer	Hewlett Packard	8901B	3403A04852	Jul. 08, 09	Jul. 31, 10
4	Digital Multi Meter	FLUKE	8846A	9642018	Jul. 06, 09	Jul. 31, 10
5	DC Power Supply	Daiichi denpa kogyo	GZV4000	90290932	None	None
6	DC Power Supply	Micky	10A	None	None	None
7	Temperature Chamber	Tabai	PL-3F	5103661	None	None
8	Temperature Meter	Sato	PC-5000TRH-II	A11999972	Apr. 15, 10	Apr. 30, 11
9	GPS Reciever	Hewlett Packard	HP Z3801A	3542A02414	None	None

Measuring Cables

No.	Cable	Manufacture	Model No.	Serial No.	Cal Date	Cal Exp.
W1	Coaxial Cable	Suhner	SUCOFLEX104	KSR00091	May 15, 09	May 31, 10
W3	Coaxial Cable	Suhner	SUCOFLEX104	KSR00042	Mar. 12, 10	Mar. 31, 11

Measuring Equipment Configuration

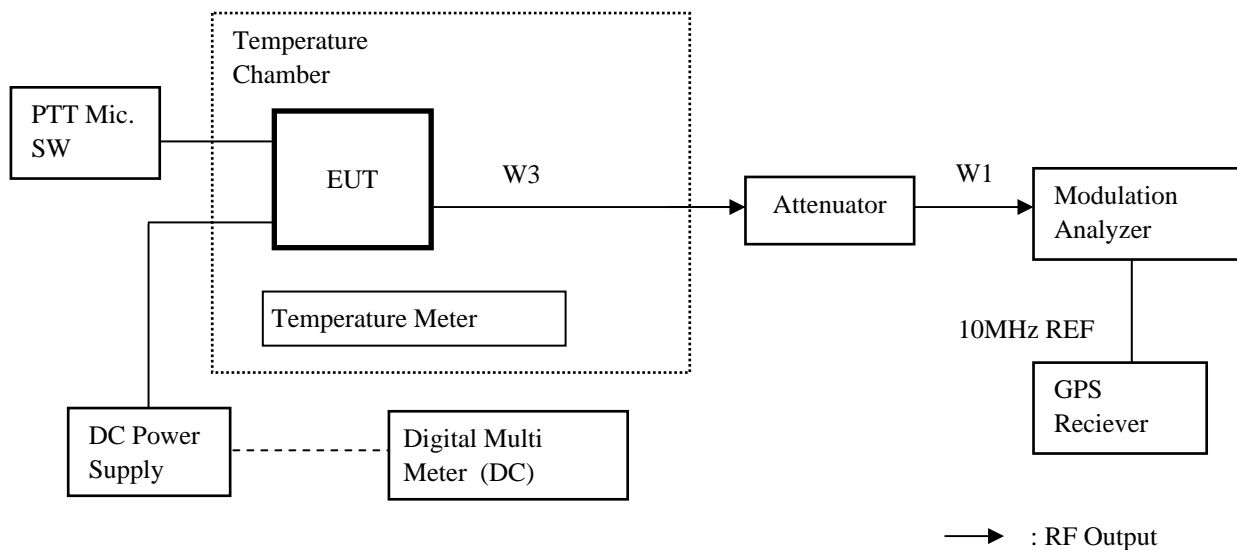

Test Results

Test date	May. 19, 2010
Location	Kashima No.1 Test Site
Test Engineer	Atsuyuki Morishima

Test was carried out for all the frequency band of section 10.1
State the worst case (below).

State : High Power / Authorized Bandwidth 20 kHz / 481.05 MHz

No.	Temperature (Degree C)	Diviation (%)	Voltage (V)	Frequency (MHz)	Stability (ppm)	Limit +/- (ppm)	Margin (ppm)
1	25 +/- 5	85	11.56	481.049990	-0.02	0.5	0.48
2	25 +/- 5	100	13.60	481.049990	-0.02	0.5	0.48
3	25 +/- 5	115	15.64	481.049980	-0.04	0.5	0.46

10.10 Necessary Bandwidth and Emission Bandwidth

REGULATIONS : FCC Part 2 Section 202 (g) & Federal Register/ Vol.68, No236

Calculation Results

State : 16K0F3E (Authorized Bandwidth 20 kHz)

Item	Mark		
Maximum Modulation	(M)	3	kHz
Maximum Deviation	(D)	5	kHz
Constant Factor	(K)	1	
Necessary Bandwidth	(Bn)	16	kHz

$$B_n = (2 \times M) + (2 \times D \times K)$$

State : 11K0F3E (Authorized Bandwidth 11.25 kHz)

Item	Mark		
Maximum Modulation	(M)	3	kHz
Maximum Deviation	(D)	2.5	kHz
Constant Factor	(K)	1	
Necessary Bandwidth	(Bn)	11	kHz

$$B_n = (2 \times M) + (2 \times D \times K)$$

State : 8K30F1E / 8K30F1D / 8K30F7W (4Level FSK / 9600bps, Authorized Bandwidth 11.25 kHz)

Item	Mark		
Digital information rate	(R)	9600	bps
Peak frequency deviation	(D)	3.391	kHz
Signaling states	(S)	4	
Numerical factor	(K)	0.516	
Necessary Bandwidth	(Bn)	8.3	kHz

$$B_n = (R / \log_2 S) + 2 \times D \times K$$

State : 4K00F1E / 4K00F1D / 4K00F7W (4Level FSK / 4800bps, Authorized Bandwidth 6 kHz)

Item	Mark		
Digital information rate	(R)	4800	bps
Peak frequency deviation	(D)	1.55	kHz
Signaling states	(S)	4	
Numerical factor	(K)	0.516	
Necessary Bandwidth	(Bn)	4	kHz

$$B_n = (R / \log_2 S) + 2 \times D \times K$$

State : 4K00F2D (CWID, Authorized Bandwidth 6 kHz)

Item	Mark		
Maximum Modulation	(M)	0.8	kHz
Maximum Deviation	(D)	1.2	kHz
Numerical factor	(K)	1	
Necessary Bandwidth	(Bn)	4	kHz

$$B_n = (2 \times M) + (2 \times D \times K)$$