



TEST REPORT

REGULATION : **FCC Part 2, 22, 74, 90, 90.210**
RSS-119 Issue 9

Applicant	Testing Laboratory
Kenwood Corporation 1-16-2, Hakusan, Midori-ku, Yokohama-shi Kanagawa, 226-8525 Japan Tel.: +81 45 939 6254 Fax.: +81 45 939 7097	Intertek Japan K. K. Kashima Laboratory 3-2, Sunayama, Kamisu-shi, Ibaraki-ken 314-0255 Japan Tel.: +81 479 40 1097 Fax.: +81 479 46 1788 Intertek Japan K. K. Tochigi Laboratory 870 Nakaawano, Kanuma-shi, Tochigi-ken 322-0306 Japan Tel.: +81 289 86 7121 Fax.: +81 289 86 7126 URL: http://www.japan.intertek-etlsemko.com

Equipment type	UHF FM TRANSCEIVER
Trademark	KENWOOD
Model(s)	TK-8302H-2
Serial No.	None
FCC ID	K44407703
IC CN and UPN	282F-407703
Test Result	Complied
Report Number	JK09080001(R1)
Report issue date	August 31, 2009

This report is for the exclusive use of Intertek's Client and is provided pursuant to the agreement between Intertek and its Client. Intertek's responsibility and liability are limited to the terms and conditions of the agreement. Intertek assumes no liability to any party, other than to the Client in accordance with the agreement, for any loss, expense or damage occasioned by the use of this report. Only the Client is authorized to permit copying or distribution of this report and then only in its entirety. Any use of the Intertek name or one of its marks for the sale or advertisement of the tested material, product or service must first be approved in writing by Intertek. The observations and test results in this report are relevant only to the sample tested. This report by itself does not imply that the material, product, or service is or has ever been under an Intertek certification program.

The test report JK09080001 was superseded by this test report.

Approved by K. Gokita

Kazuo Gokita
 [Site Manager]

Tested by K. Wagatsuma

Koichi Wagatsuma

In Accordance with FCC Rules and Regulations, Volume II, Part 2 and 90**Sub-part 2.1033**

(c)(1) Applicant and Manufacture Information	
APPLICANT	
Company	: Kenwood Corporation
Address	: 1-16-2, Hakusan, Midori-ku, Yokohama-shi, Kanagawa, 226-8525 Japan
Contact Person	: Tamaki Shimamura Manager, Communications Equipment Division
MANUFACTURER	
Company	: Kenwood Corporation
Address	: 1-16-2, Hakusan, Midori-ku, Yokohama-shi, Kanagawa, 226-8525 Japan
(c)(2) FCC ID	
FCC ID	: K44407703
Model number	: TK-8302H-2
Serial number	: None
(c)(3) Instruction Manual(S)	
Instruction manual(s)	: Please refer to attached Exhibits F
(c)(4) Type of Emission	
Emission Designation	: 16K0F3E(Wide) /11K0F3E(Narrow)
(c)(5) Frequency range	
Frequency Range	: 406.1 to 470 MHz(CFR), 406.1 to 430MHz and 450 to 470 MHz(RSS)
(c)(6) Power Rating	
Output Power	: 5 to 45 W
Type	: Continuously Variable
(c)(7) Maximum Power Rating	
Output Power	: 45 W
(c)(8): Voltages & currents in all elements in final RF stage, including final transistor or solid-state device	
Collector Current, A	: 15.0 amps (Maximum)
Collector Voltage, Vdc	: 13.6 vdc
Supply Voltage, Vdc	: 13.6 vdc
Other Information	
Number of Channel	: 16
Maximum Deviation	: 5 kHz / 2.5kHz
Frequency Stability	: 2.5 ppm
Antenna Impedance	: 50 Ω Norminal
Note	

TABLE OF CONTENTS

	Page
SECTION 1. GENERAL INFORMATION	4
SECTION 2. SUMMARY OF TEST RESULT	5
SECTION 3. TEST AND MEASUREMENT DATA	6
SECTION 4. INFORMATION ABOUT EUT AND SUPPORT EQUIPMENT(S)	7
SECTION 5. SUPPORT EQUIPMENT	8
SECTION 6. USED CABLE(S)	9
SECTION 7. TEST CONFIGURATION	10
SECTION 8. OPERATING CONDITION	11
SECTION 9. MEASUREMENT UNCERTAINTY	12
SECTION 10. TEST DATA	
10.1 Carrier Output Power (Conducted)	13
10.2 Unwanted Emissions (Transmitter Conducted)	15
10.3 Field Strength of Spurious Radiation	18
10.4 Emission Masks (Occupied Bandwidth)	22
10.5 Transient Frequency Behavior	28
10.6 Audio Frequency Response / Audio Low Pass Filter (Voice Input)	32
10.7 Modulation Limiting	35
10.8 Frequency Stability (Temperature Variation)	39
10.9 Frequency Stability (Voltage Variation)	42
10.10 Receiver Spurious Emissions(Radiated)	44
10.11 Necessary Bandwidth and Emission Bandwidth	48
APPENDIX PHOTOGRAPHS	

SECTION 1. GENERAL INFORMATION**TEST PERFORMED**

Location	Kashima No.1 Test Site and Tochigi No.2 Test Site		
EUT Received	August 17, 2009		
Date of Test	August 17, 2009	to	August 26, 2009
Standard Applied	FCC Part 2, 22, 74, 90, 90.210 RSS-119 Issue 9		
Measurement Method	ANSI/TIA-603-C-2004 / RSS-119 Issue 9(2007), RSS-Gen Issue 2(2007)		
Deviation from Standard(s)	Not applicable		

QUALIFICATIONS OF TESTING LABORATORY (Kashima Lab.)

ACCREDITATION	SCOPE	LAB. CODE	Remarks
NVLAP	EMC Testing	100290-0	
VLAC	EMC Testing	VLAC-008-1	JAPAN
BSMI	EMC Testing	SL2-IN-E-6008	TAIWAN
FILING			
VCCI	EMC Testing	R-788, C-278, C-279, T-351, T-352 R-274, C-280, C-281, T-353, T-359 R-272, C-276, C-277, T-360, T-361 R-576, C-590, T-362	JAPAN
FCC	EMC Testing	Designation Number:JP0008	USA
IC	EMC Testing	IC-2042K-1, IC-2042K-3	CANADA
SAUDI ARABIA	EMC Testing	N/A	

QUALIFICATIONS OF TESTING LABORATORY (Tochigi Lab.)

ACCREDITATION	SCOPE	LAB. CODE	Remarks
VLAC	EMC Testing	VLAC-008-5	JAPAN
FILING			
VCCI	EMC Testing	R-257, C-260, C-284, T-374, T-375 R-258, C-261, C-285, T-376, T-377 R-259, C-262, T-378	JAPAN
FCC	EMC Testing	Designation Number:JP0011	USA
IC	EMC Testing	IC-2042P-1, IC-2042P-2	CANADA
SAUDI ARABIA	EMC Testing	N/A	

ABBREVIATIONS

EUT	Equipment Under Test	DoC	Declaration of Conformity
AMN	Artificial Mains Network	ISN	Impedance Stabilization Network
LISN	Line Impedance Stabilization Network	Q-P	Quasi-peak
AMP	Amplifier	AVG	Average
ATT	Attenuator	PK	Peak
ANT	Antenna	Cal	Calibration
BBA	Broadband Antenna	N/A	Not applicable or Not available
DIP	Dipole Antenna	LCD	Liquid-Crystal Display
AE	Associated Equipment	4LEVEL FSK	4LEVEL Frequency Shift Key
GMSK	Gaussian Maximum Shift Key	CW ID	Continuously Repeating bit stream
FM	Frequency Modulation	C4FM	Constant envelope 4 Level FM
PTT	Push to Talk		

SECTION 2. SUMMARY OF TEST RESULT

FCC Part2	Part22	Part74	Part90	IC RSS-119	TEST ITEM	RESULTS
2.1046 (a)	-	74.461	-	5.4	Carrier Output Power (Conducted)	PASS
2.1051	-	-	90.210	5.8	Unwanted Emissions (Transmitter Conducted)	PASS
2.1053 (a)	-	-	90.210	5.8	Field Strength of Spurious Radiation	PASS
2.1049 (c) (1)	22.359, 357 (a)	74.462	90.210	5.8	Emission Masks (Occupied Bandwidth)	PASS
-	-	-	90.214	5.9	Transient Frequency Behavior	PASS
2.1047 (a)	-	-	90.242 (b) (8)	-	Audio Low Pass Filter (Voice Input)	PASS
2.1047 (a)	-	-	-	-	Audio Frequency Response	PASS
2.1047 (b)	-	-	-	-	Modulation Limiting	PASS
2.1055 (a) (1)	22.355	74.464	90.213 (a)	5.3	Frequency Stability (Temperature Variation)	PASS
2.1055 (d) (1)	22.355	74.464	90.213 (a)	5.3	Frequency Stability (Voltage Variation)	PASS
-	-	-	-	5.11	Receiver Spurious Emissions	PASS

Limitation on Results

The test result of this report is effective equipment under test itself and under the test configuration described on the report. This test report does not assure that whether the test result taken in other testing laboratory is compatible or reproducible to the test result on this report or not.

Note:

As for the FCC Part 15 Subpart B-Unintentional Radiators, the EUT has been measured and declared as Verification by Kenwood Corporation.

SECTION 3. TEST AND MEASUREMENT DATA

All test and measurements indicated in this document were performed in accordance with the Code of Federal Regulations Title 47 Part 2, Sub-part J and Industry Canada as the following individual parts:

FCC Rule	Test Item	Tested
Part 21	Domestic Public Fixed radio Services	N.A.
Part 22	Non Cellular	YES
Part 22	Public Mobile Services	N.A.
Part 22	Subpart H - Cellular Radiotelephone Service	N.A.
Part 22	Alternative technologies and auxiliary service	N.A.
Part 23	International Fixed Public Radiocommunication service	N.A.
Part 24	Personal Communications Services	N.A.
Part 74	Experimental Radio Auxiliary , Special Broadcast and Other Program Distributional Services	YES
Part 80	Stations in the Maritime Services	N.A.
Part 80	Subpart E - general Technical Standards	N.A.
Part 80	Subpart F - Equipment Authorization for Compulsory Ships	N.A.
Part 80	Subpart K - Private Coast Stations and Marine Utility Stations	N.A.
Part 80	Subpart S - Compulsory radiotelephone Installations for Small Passenger Boats	N.A.
Part 80	Subpart T - Radiotelephone Installation Required for Vessels on the Great Lakes	N.A.
Part 80	Subpart U - Radiotelephone Installations Required by the Bridge-to-Bridge Act	N.A.
Part 80	Subpart V - Emergency Position Indicating Radiobeacons (EPIRB'S)	N.A.
Part 80	Subpart W - Global Maritime Distress and Safety System (GMDSS)	N.A.
Part 80	Subpart X - Voluntary Radio Installations	N.A.
Part 87	Aviation Services	N.A.
Part 90	Private Land Mobile radio Services	YES
Part 94	Private Operational - Fixed Microwave Service	N.A.
Part 95	Subpart A - General Mobile radio Service	N.A.
Part 95	Subpart C - Radio Control (R/C) radio Service	N.A.
Part 95	Subpart D - Citizens Band (CB) Radio Service	N.A.
Part 95	Subpart E -Family radio Service	N.A.
Part 95	Subpart F -Interactive Video and Data Service (IVDS)	N.A.
Part 97	Amateur Radio Service	N.A.
Part 101	Fixed Microwave Service	N.A.

IC Rule	Test Item	Tested
RSS-119	Land Mobile and Fixed Radio Transmitters and Receivers	YES
RSS-Gen	General Requirements and Information for the Certification of Radiocommunication Equipment	YES

SECTION 4. INFORMATION ABOUT EUT AND SUPPORT EQUIPMENT(S)**4.1 List of System Configuration**

Symbol	Item	Model No.	Serial No.	Manufacture	Remarks
A	UHF FM TRANSCEIVER	TK-8302H-2	None	Kenwood	EUT
Power Ratings of EUT :		DC 13.6 V +/- 15 %	15.0 A Maximum		
Power Supply :		DC 13.6 V +/- 15 %			
Condition of Equipment		Proto type			
Type		Mobile type			
Suppression Devices		No Modifications by the laboratory were made to the device			

4.2 Port(s)/Connector(s)

Port Name	Connector Type	Connector Pin	Remarks
ACC	D-sub	15 pin	
Speaker	3.5φ	2 pin	
Antenna	M	2 pin	
Microphone	Kenwood original	12 pin	

4.3 Highest Frequency Oscillator(s)/Crystal(s)

Base Clock	Operating Frequenc	Board Name	Remarks
470 MHz	470 MHz	TXRX Unit	

SECTION 5. SUPPORT EQUIPMENT

The EUT was supported by the following equipment during the test.

Symbol	Item	Model No.	Serial No.	Manufacture	FCC ID
B	DC Power Supply	GZV4000	90290932	Daiichi denpa kogyo	N/A
F	DC Power Supply	10A	None	Micky	N/A
C	External Speaker	KES-5	None	Kenwood	N/A
D	Keypad Microphone	KMC-32	None	Kenwood	N/A
E	Dummy Load	CT-150NP	1138693	TME	N/A
Supplied Power:					
B, F	AC	100V,60Hz			

SECTION 6. USED CABLE(S)

The following cable(s) was used for the test.

No.	Name	Length (m)	Shield	Connector
1	Speaker cable	2.90	No	Plastic
2	Antenna cable	0.90	Yes	Metal
3	Mic. cable	0.55	No	Plastic
4	DC cable for EUT	0.25	Yes	Plastic
5	KCT-60(Connection cable)	0.30	No	Plastic
6	KCT-18(Ignition sense cable)	3.15	No	Plastic
7	DC cable for EUT	3.00	No	Plastic
8	Power cable for DC Power Supply	1.70	No	-

SECTION 7. TEST CONFIGURATION

Details of Configuration and Connection

Example: Case of Section 10.3 Test

* : EUT

□ : Joint Connector

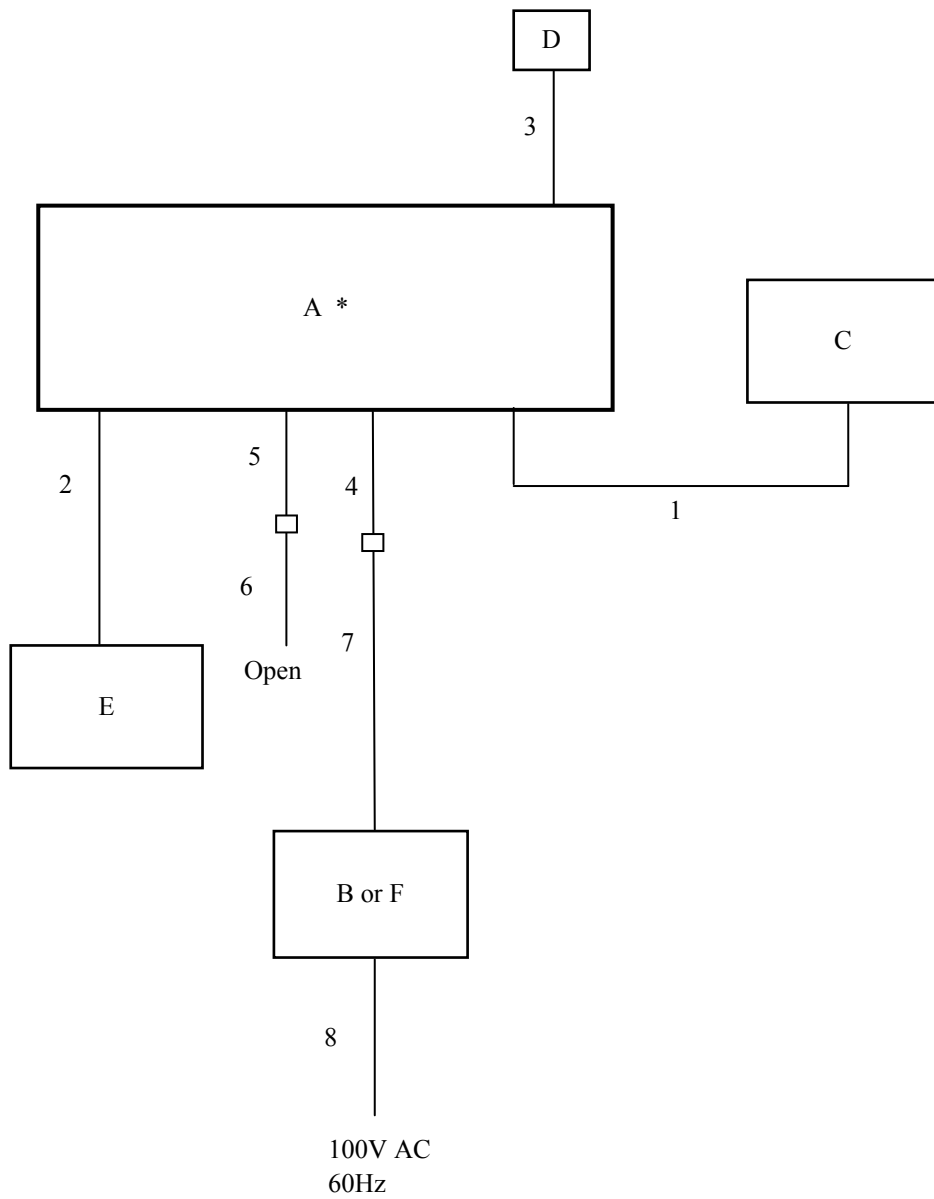

SECTION 8. OPERATING CONDITION

The EUT was operated under the following condition during the test.

8.1 Operating Condition

The test was carried out under Transmit mode.

(CFR:406.15MHz, 438.05MHz, 469.95MHz, RSS:406.15MHz, 428.05MHz, 469.95MHz)

The test was carried out under Recive mode.

(RSS:406.15MHz, 428.05MHz, 469.95MHz)

EUT was examined in the operating conditions that had maximum emissions.

8.2 Operating Flow [Transmit mode]

Following operations were performed continuously.

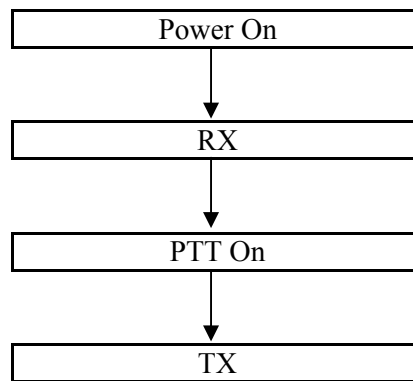

8.3 Operating Flow [Recive mode]

Following operations were performed continuously.

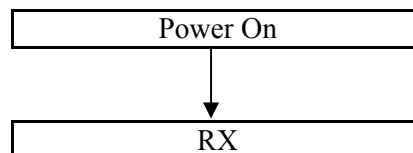

SECTION 9. MEASUREMENT UNCERTAINTY

Carrier Output Power (Conducted)	U_{lab}	$U_{tia-603-c}$
	+/- 0.29dB ($k = 2$)	+/- 0.59 dB
Unwanted Emissions (Transmitter Conducted)		
	+/- 2.19 dB ($k = 2$)	+/- 1.1 dB
Field Strength of Spurious Radiation		
	+/- 3.9dB ($k = 2$)	+/- 3.3 dB
Emission Masks (Occupied Bandwidth)		
	+/- 0.5dB ($k = 2$)	+/- 2.1 dB
Transient Frequency Behavior		
	+/- 1.10% ($k = 2$)	+/- 21.6 %
Audio Low Pass Filter (Voice Input)		
	+/- 0.1dB ($k = 2$)	+/- 1.2 dB
Audio Frequency Response		
	+/- 0.1dB ($k = 2$)	+/- 1.2 dB
Modulation Limiting		
	+/- 1% ($k = 2$)	+/- 1 %
Frequency Stability (Temperature Variation)		
	+/- 14.9Hz ($k=2$)	+/-34.2 Hz
Frequency Stability (Voltage Variation)		
	+/- 14.9Hz ($k=2$)	+/-34.2 Hz
Receiver Spurious Emissions	U_{lab}	U_{cispr}
30-1000MHz	+/- 3.7dB ($k = 2$)	+/- 5.2 dB
1-40GHz	+/- 4.3dB ($k = 2$)	

SECTION 10. TEST DATA

10.1 Carrier Output Power (Conducted)

REGULATIONS	: 47 CFR 2.1046 (a) / RSS-119 Section 5.4
TEST METHOD/GUIDE	: ANSI/TIA-603-C Section 2.2.1.2 / RSS-119 Section 4.1

Test Procedure

- 1 The EUT and test equipment were set up as shown on the following page.
- 2 The EUT was conducted to a resistive coaxial attenuator of normal load impedance.
 $RF\ Power\ (dBm) = Power\ Meter\ reading\ (dBm) + Attenuator\ Loss\ (dB) + Cable\ Loss\ (dB)$
 $RF\ Power\ (W) = 10^{(RF\ Power\ (dBm)/10)}/1000$
- 3 Modulate the transmitter with a 2.5 kHz sine wave at an input Level of 16 dB greater than that necessary to produce 50 % of rated system deviation.(Only as for the test of RSS)

Measuring Equipments

No.	Equipment	Manufacture	Model No.	Serial No.	Cal Date	Cal Exp.
1	Power Meter	Hewlett Packard	E4418B	GB38410265	May 26, 09	May. 31, 10
2	Power Sensor	Hewlett Packard	8482A	US37292237	May 26, 09	May. 31, 10
3	Attenuator (20dB)	Aeroflex/Wenschel	66-20-34	BY4537	Mar. 30, 09	Mar. 31, 10
4	Attenuator (30dB)	Weinschel	WA-29-30-34	8924	May. 15, 09	May. 31, 10
5	Audio Generator	Anritsu	MG443B	M70150	Apr. 01, 09	Apr. 30, 10
6	Digital Multi Meter	Agilent	34401A	3146A08906	Dec. 17, 08	Dec. 31, 09
7	Modulation Analyzer	Hewlett Packard	8901B	3403A04852	Jul. 08, 09	Jul. 31, 10
8	DC Power Supply	Daiichi denpa kogyo	GZV4000	90290932	None	None

Measuring Cables

No.	Cable	Manufacturer	Model No.	Serial No.	Cal Date	Cal Exp.
W1	Coaxial Cable	Suhner	SUCOFLEX104	KSR00091	May. 15, 09	May. 31, 10
W4	Coaxial Cable	Pacific custom	RG-58 C/U	AM90C03	Jan. 14, 09	Jan. 31, 10
W6	Balance Cable	Nicoon	3D-2V	KSR00092	Oct. 09, 08	Oct. 31, 09

Measuring Equipment Configuration

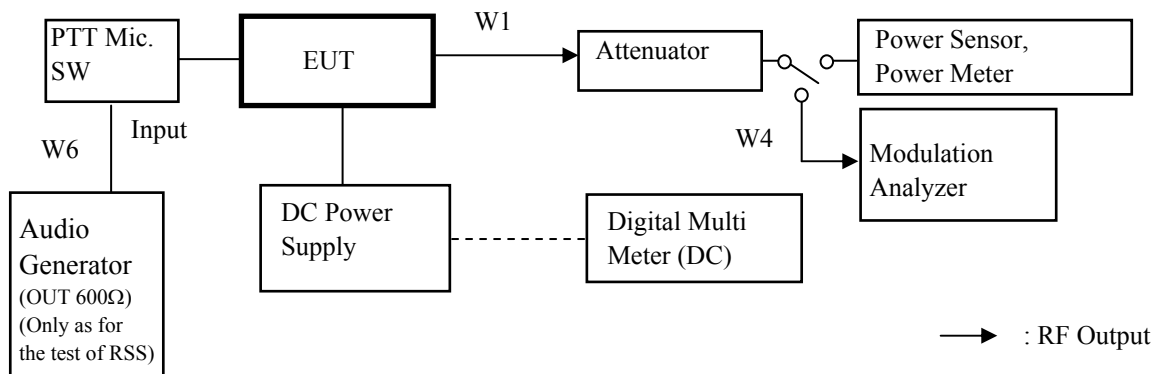

Test Results

Test date	Aug 17, 2009		
Location	Kashima No.1 Test Site		
temperature	24 to 26.4	[degree C]	
Humidity Variation	46 to 60	[%]	
Atmospheric Pressure	101.4to 101.6	[kPa]	
Test Engineer	Koichi Wagatsuma		

Test was carried out for all the Authorized Bandwidth.

State the worst case (below).

No.	Frequency (MHz)	Band		Setting	RF Power (W)
1	406.15	Low	(CFR/RSS)	High Power	45
2	428.05	Middle	(RSS)	High Power	45
3	438.05	Middle	(CFR)	High Power	45
4	469.95	High	(CFR/RSS)	High Power	45
5	406.15	Low	(CFR/RSS)	Low Power	5
6	428.05	Middle	(RSS)	Low Power	5
7	438.05	Middle	(CFR)	Low Power	5
8	469.95	High	(CFR/RSS)	Low Power	5

RF Power:Peak reading

10.2 Unwanted Emissions (Transmitter Conducted)

REGULATIONS : 47 CFR 2.1051, 90.210 / RSS-119 Section 5.8

TEST METHOD/GUIDE : ANSI/TIA-603-C Section 2.2.13.2 / RSS-119 Section 4.2, RSS-Gen Section 4.9

Test Procedure

- 1 The EUT and test equipment were set up as shown on the following page.
- 2 Modulate the transmitter with a 2.5 kHz sine wave at an input Level of 16 dB greater than that necessary to produce 50 % of rated system deviation.
- 3 Adjust the spectrum analyzer for the following setting:
 - a) RBW : 10 kHz (< 1 GHz), 1 MHz (> 1 GHz).
 - b) VBW : 30 kHz (< 1 GHz), 3 MHz (> 1 GHz).
 - c) Sweep Speed : 50 msec.
 - d) Detector mode : Average power (FM Modulation) , Positive peak with peak hold (C4FM Modulation)
- 4 The emissions were measured for the worst case as follows:
 - a) : within a band of frequencies defined by the carrier frequency plus and minus one channel.
 - b) : from the lowest frequency generated in the EUT and to at least the 10th harmonic of the carrier frequency, or 40 GHz, whichever is lower.

Measuring Equipments

No.	Equipment	Manufacture	Model No.	Serial No.	Cal Date	Cal Exp.
1	Audio Generator	Anritsu	MG443B	M70150	Apr. 01, 09	Apr. 30, 10
2	Attenuator (20dB)	Aeroflex/Wenshel	66-20-34	BY4357	Mar. 30, 09	Mar. 31, 10
3	Attenuator (30dB)	Weinschel	WA-29-30-34	8924	May. 15, 09	May. 31, 10
4	Highpass Filter	Anritsu	MP526D	6200220657	Jan. 14, 09	Jan. 31, 10
5	Modulation Analyzer	Hewlett Packard	8901B	3403A04852	Jul. 08, 09	Jul. 31, 10
6	Signal Generator	Rohde&Schwarz	SMT06	100684	Dec 12, 08	Dec. 31, 09
7	Spectrum Analyzer	Agilent	E4407B	MY45102460	Feb. 09, 09	Feb. 28, 10
8	Digital Multi Meter	Agilent	34401A	3146A08906	Dec. 17, 08	Dec. 31, 09
9	DC Power Supply	Daiichi denpa kogyo	GZV4000	90290932	None	None

Measuring Cables

No.	Cable	Manufacturer	Model No.	Serial No.	Cal Date	Cal Exp.
W1	Coaxial Cable	Suhner	SUCOFLEX104	KSR00091	May. 15, 09	May. 31, 10
W2	Coaxial Cable	Suhner	SUCOFLEX104	KSR00042	Mar. 12, 09	Mar. 31, 10
W4	Coaxial Cable	Pacific custom	RG-58 C/U	AM90C03	Jan. 14, 09	Jan. 31, 10
W6	Balance Cable	Nicoon	3D-2V	KSR00092	Oct. 09, 08	Oct. 31, 09

Measuring Equipment Configuration

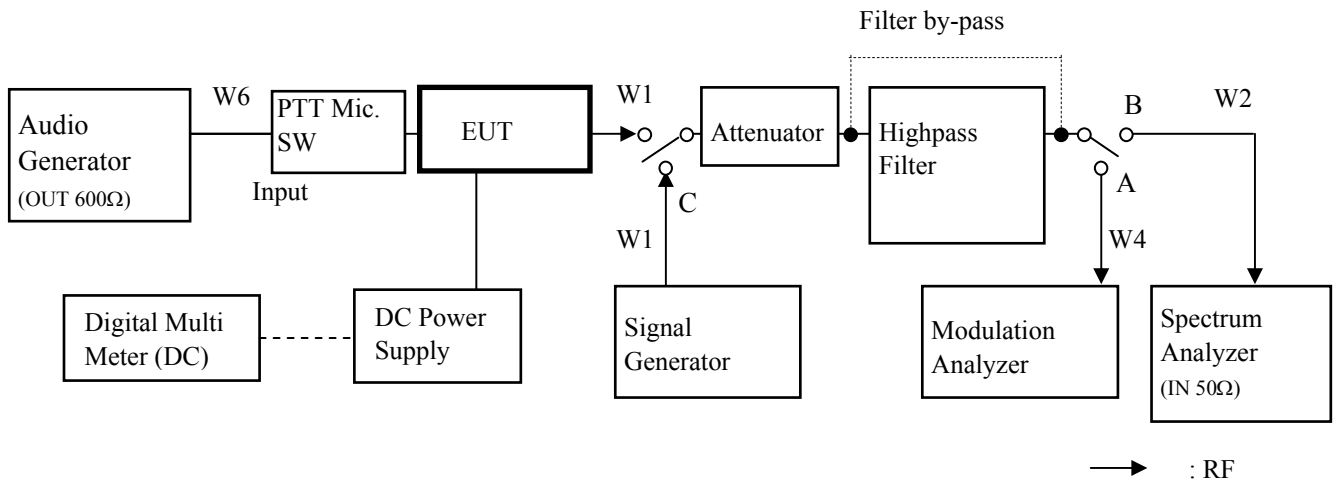

Test Results

Test date	Aug 18, 2009
Location	Kashima No.1 Test Site
temperature	23.7 to 26.9 [degree C]
Humidity Variation	48 to 63 [%]
Atmospheric Pressure	101.4 to 101.5 [kPa]
Test Engineer	Koichi Wagatsuma

Test was carried out for all the frequency band of section 10.1

State the worst case (below).

State : High Power / Authorized Bandwidth 11.25 kHz

No.	Band	Frequency (MHz)	Correct Level (dBm)	Emission Level (dBc)	Limit (dBc)	Margin (dB)
1	Low (CFR/RSS)	812.30	-34.50	-81.03	-66.5	14.5
2	Middle (RSS)	1712.20	-27.50	-74.03	-66.5	7.5
3	Middle (CFR)	1752.20	-28.40	-74.93	-66.5	8.4
4	High (CFR/RSS)	939.90	-33.50	-80.03	-66.5	13.5

There is the margin of 20dB over except for the above points.

State : Low Power / Authorized Bandwidth 11.25 kHz

No.	Band	Frequency (MHz)	Correct Level (dBm)	Emission Level (dBc)	Limit (dBc)	Margin (dB)
1	Low (CFR/RSS)	812.30	-38.70	-75.69	-57.0	18.7
2	Middle (RSS)	856.10	-41.60	-78.59	-57.0	21.6
3	Middle (CFR)	876.10	-42.50	-79.49	-57.0	22.5
4	High (CFR/RSS)	939.90	-40.70	-77.69	-57.0	20.7

There is the margin of 20dB over except for the above points.

Mask D Limit (dBc) = $-(50+10\log(P))$

Correct Level (dBm) = Substitute SG Level (dBm)

Emission Level (dBc) = Correct Level (dBm) - $10\log(P*1000)$

P = Carrier Level (W)

" - " = Measurement Limit

10.3 Field Strength of Spurious Radiation

REGULATIONS	: 47 CFR 2.1053 (a), 90.210 / RSS-119 Section 5.8
TEST METHOD/GUIDE	: ANSI/TIA-603-C Section 2.2.12.2 / RSS-119 Section 4.2, RSS-Gen Section 4.9

Test Procedure

- 1 The EUT and test equipment were set up as shown on the following page.
- 2 Adjust the spectrum analyzer for the following setting:
 - a) RBW : 10 kHz (< 1 GHz), 1 MHz (> 1 GHz).
 - b) VBW : 300 kHz (< 1 GHz), 3 MHz (> 1 GHz).
 - c) Sweep Speed : 50ms.
 - d) Detector mode : Positive Peak
- 3 The transmitter was placed on a wooden turntable, and it was transmitting into non-radiating load which was also placed on the turntable.
- 4 The measurement antenna was placed at a distance of 3 meters from the EUT. During the tests, the antenna height and polarization as well as EUT azimuth were varied in order to identify the maximum level of emissions from the EUT. The test was performed by placing the EUT on 3-orthogonal axis.
- 5 The frequency range up to tenth harmonic of the fundamental frequency was investigated.
- 6 Remove the EUT and replace it with substitution antenna. A signal generator was connected to the substitution antenna by a non-radiating cable. The absolute levels of the spurious emissions were measured by the substitution.
- 7 Spurious emissions in dB = 10 Log (TX power in Watts/0.001) – the absolute level

Measuring Equipments

No.	Equipment	Manufacture	Model No.	Serial No.	Cal Date	Cal Exp.
1	Dipole Antenna(TX)	Schwarzbeck	UHA9105	AM0082002	May 18, 09	May. 31, 10
2	D.R.G Antenna(TX)	Schwarzbeck	3117	KSR00038	Aug 13, 09	Aug. 31, 10
3	Tri-log Antenna(RX)	Schwarzbeck	VULB9168	218	Mar 05, 09	Mar. 31, 10
4	D.R.G Antenna(RX)	EMCO	3115	9903-5699	Apr. 28, 09	Apr. 30, 10
5	Pre-Amplifier	Hewlett Packard	8449B	3008A01182	Apr. 22, 09	Apr. 30, 10
6	Attenuator(6dB)	TAMAGAWA	CFA-01(NPJ-6)	None	May. 20, 09	May. 31, 10
7	Attenuator(6dB)	Hewlett Packard	8493C	18493	Apr. 22, 09	Apr. 30, 10
8	Attenuator(10dB)	HUBER+SUHNER	6810.17B	KSR0044	Jan. 14, 09	Jan. 31, 10
9	Spectrum Analyzer	Hewlett Packard	8563E	3821A09565	Dec. 18, 08	Dec. 31, 09
10	Signal Generator	Rohde&Schwarz	SMT06	100684	Dec. 12, 08	Dec. 31, 09
11	Dummy Load	TME	CT-150NP	1138693	Sep. 09, 08	Sep. 30, 09
12	Digital Multi Meter	Agilent	34401A	3146A08906	Dec. 17, 08	Dec. 31, 09
13	DC Power Supply	Daiichi denpa kogyo	GZV4000	90290932	None	None

Measuring Cables

No.	Cable	Manufacturer	Model No.	Serial No.	Cal Date	Cal Exp.
W1	Coaxial Cable	Suhner	SUCOFLEX104	KSR00091	May. 15, 09	May. 31, 10
R1	Coaxial Cable	Intertek Japan	5D-2W	2R1001a	May. 20, 09	May. 31, 10
R2	Coaxial Cable	Intertek Japan	RG-177/U	2R1002	May. 20, 09	May. 31, 10
R3	Coaxial Cable	Intertek Japan	RG-5A/U	2R1003	May. 20, 09	May. 31, 10
R8	Coaxial Cable	Intertek Japan	5D-2W	2R1008a	May. 20, 09	May. 31, 10
R16	Coaxial Cable	Suhner	SUCOFLEX104	290799/4	Apr. 22, 09	Apr. 30, 10
R17	Coaxial Cable	Suhner	SUCOFLEX104	290800/4	Apr. 22, 09	Apr. 30, 10
W12	Coaxial Cable	Intertek Japan	5D-2W	KSR00099	Jan. 14, 09	Jan. 31, 10
W13	Coaxial Cable	Suhner	SUCOFLEX104	KSR00207	Jun. 12, 09	Jun. 30, 10

Measuring Equipment Configuration

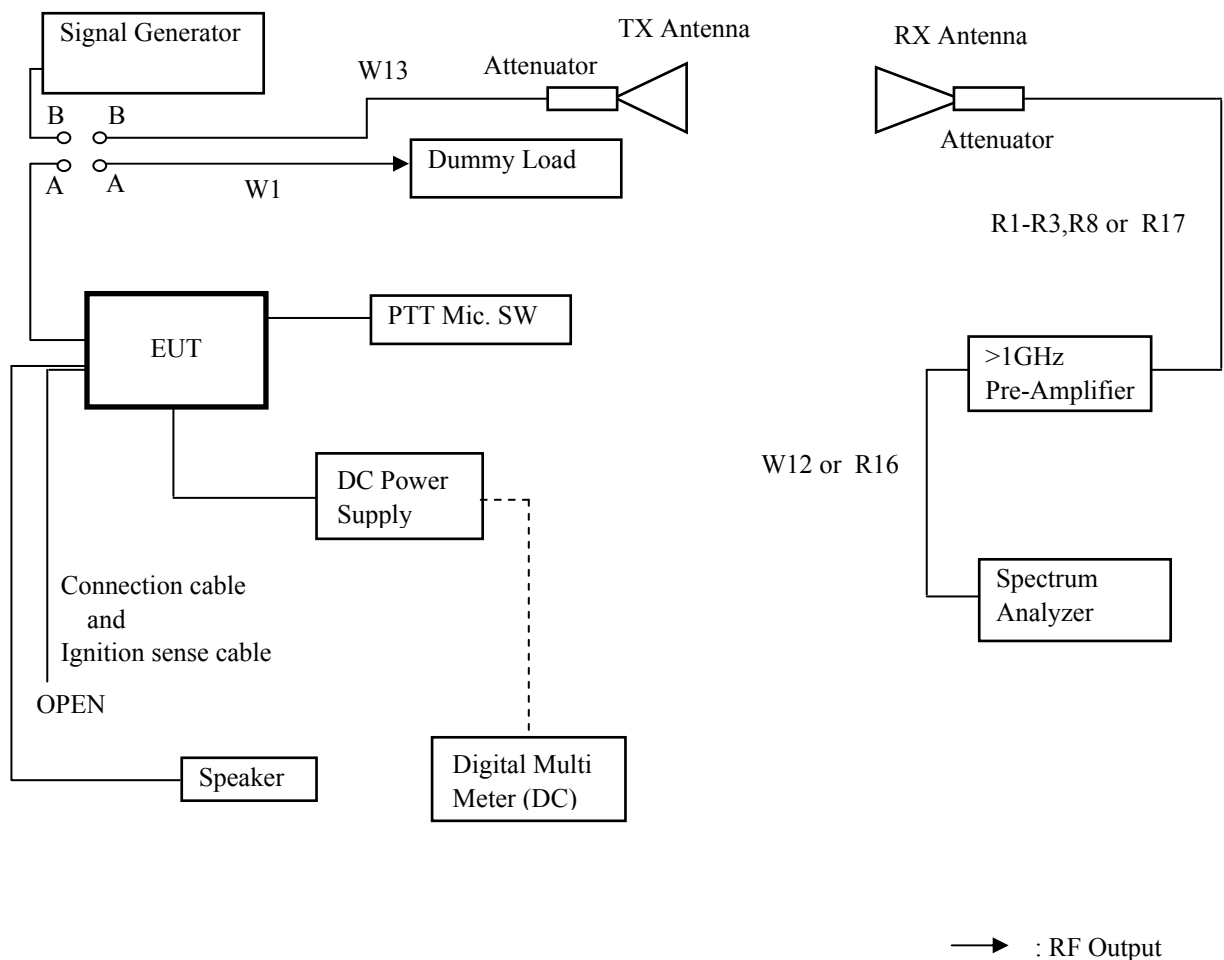

Test Results

Test date	Aug 20, 2009	to	Aug 21, 2009
Location	Tochigi No.2 Test Site		
temperature	21.4 to 23.6		[degree C]
Humidity Variation	46 to 65		[%]
Atmospheric Pressure	98.2-98.5		[kPa]
Test Engineer	Koichi Wagatsuma		

Test was carried out for all the frequency band of section 10.1

State the worst case (below).

State : High Power / Authorized Bandwidth 11.25 kHz / 469.95 MHz (CFR/RSS)

No	Frequency (MHz)	Pol	Reading Level (dBm)	SG Out Level (dBm)	Loss (dB)	Antenna Gain (dBi)	Correct Level (dBm)	Emission Level (dBc)	Limit Level (dBc)	Margin (dB)
1	939.90	Hor.	-84.83	-24.80	12.26	2.15	-34.9	-81.4	-66.5	14.9
		Ver.	-72.95	-12.30	12.26	2.15	-22.4	-68.9	-66.5	2.4
2	1409.85	Hor.	-41.42	-26.90	12.82	5.33	-34.4	-80.9	-66.5	14.4
		Ver.	-38.33	-24.70	12.82	5.33	-32.2	-78.7	-66.5	12.2
3	1879.80	Hor.	-49.58	-32.70	13.29	4.92	-41.1	-87.6	-66.5	21.1
		Ver.	-48.33	-31.00	13.29	4.92	-39.4	-85.9	-66.5	19.4
4	2349.75	Hor.	-53.50	-36.90	13.81	5.76	-44.9	-91.5	-66.5	24.9
		Ver.	-49.50	-30.40	13.81	5.76	-38.4	-85.0	-66.5	18.4
5	2819.70	Hor.	-58.00	-42.40	14.26	7.01	-49.6	-96.2	-66.5	29.6
		Ver.	-57.92	-41.30	14.26	7.01	-48.5	-95.1	-66.5	28.5
6	3289.65	Hor.	-	-	14.63	7.74	-	-	-66.5	-
		Ver.	-	-	14.63	7.74	-	-	-66.5	-
7	3759.60	Hor.	-	-	14.96	8.33	-	-	-66.5	-
		Ver.	-	-	14.96	8.33	-	-	-66.5	-
8	4229.55	Hor.	-	-	15.29	9.23	-	-	-66.5	-
		Ver.	-	-	15.29	9.23	-	-	-66.5	-
9	4699.50	Hor.	-	-	15.62	9.27	-	-	-66.5	-
		Ver.	-	-	15.62	9.27	-	-	-66.5	-

There is the margin of 20dB over except for the above points.

Mask D Limit (dBc) = $-(50+10\log(P))$

Correct Level (dBm) = Substitute SG Level (dBm) + ANT Gain (dB) - Loss (Cable, Attenuator) (dB)

Emission Level (dBc) = Correct Level (dBm) - $10\log(P*1000)$

P = Carrier Level (W)

" - " = Measurement Limit

State : Low Power / Authorized Bandwidth 11.25 kHz / 469.95 MHz (CFR/RSS)

No	Frequency (MHz)	Pol	Reading Level (dBm)	SG Out Level (dBm)	Loss (dB)	Antenna Gain (dBi)	Correct Level (dBm)	Emission Level (dBc)	Limit Level (dBc)	Margin (dB)
1	939.90	Hor.	-86.25	-26.30	12.26	2.15	-36.4	-73.4	-57.0	16.4
		Ver.	-80.92	-20.20	12.26	2.15	-30.3	-67.3	-57.0	10.3
2	1409.85	Hor.	-39.83	-25.40	12.82	5.33	-32.9	-69.9	-57.0	12.9
		Ver.	-33.92	-20.40	12.82	5.33	-27.9	-64.9	-57.0	7.9
3	1879.80	Hor.	-47.83	-30.90	13.29	4.92	-39.3	-76.3	-57.0	19.3
		Ver.	-48.92	-31.30	13.29	4.92	-39.7	-76.7	-57.0	19.7
4	2349.75	Hor.	-49.75	-32.80	13.81	5.76	-40.8	-77.8	-57.0	20.8
		Ver.	-47.25	-27.90	13.81	5.76	-35.9	-72.9	-57.0	15.9
5	2819.70	Hor.	-61.08	-47.10	14.26	7.01	-54.3	-91.3	-57.0	34.3
		Ver.	-61.42	-48.50	14.26	7.01	-55.7	-92.7	-57.0	35.7
6	3289.65	Hor.	-	-	14.63	7.74	-	-	-57.0	-
		Ver.	-	-	14.63	7.74	-	-	-57.0	-
7	3759.60	Hor.	-	-	14.96	8.33	-	-	-57.0	-
		Ver.	-	-	14.96	8.33	-	-	-57.0	-
8	4229.55	Hor.	-	-	15.29	9.23	-	-	-57.0	-
		Ver.	-	-	15.29	9.23	-	-	-57.0	-
9	4699.50	Hor.	-	-	15.62	9.27	-	-	-57.0	-
		Ver.	-	-	15.62	9.27	-	-	-57.0	-

There is the margin of 20dB over except for the above points.

Mask D Limit (dBc) = $-(50+10\log(P))$

Correct Level (dBm) = Substitute SG Level (dBm) + ANT Gain (dB) - Loss (Cable, Attenuator) (dB)

Emission Level (dBc) = Correct Level (dBm) - $10\log(P*1000)$

P = Carrier Level (W)

" - " = Measurement Limit

10.4 Emission Masks (Occupied Bandwidth)

REGULATIONS : 47 CFR 2.1049 (c) (1), 22.359, 357 (a) (1) , 74.462 , 90.210 / RSS-119 Section 5.8

TEST METHOD/GUIDE : ANSI/TIA-603-C Section 2.2.11.2 / RSS-119 Section 4.2.1, 4.2.2

Test Procedure

- 1 The EUT and test equipment were set up as shown on the following page.
- 2 For EUT supporting audio modulation, the audio signal generator was adjusted to the frequency of maximum response and with output level set for +/- 2.5 kHz deviation (or 50 % modulation).
- 3 With level constant, the signal level was increased 16 dB.
- 4 Adjust the spectrum analyzer for the following setting:
 - a) RBW : 100Hz (Non modulation and Authorized Band 11.25 kHz),
300Hz (Non modulation and Authorized Band 20 kHz).
 - b) VBW : 10times the RBW (Non modulation , Authorized Band 11.25 kHz and Authorized Band 20 kHz).
 - c) Sweep Speed : 8 sec.
 - d) Sampling Time : 10 times
- 5 The occupied Bandwidth was measured with the Spectrum Analyzer controls set as shown on the test results.

Measuring Equipments

No.	Equipment	Manufacture	Model No.	Serial No.	Cal Date	Cal Exp.
1	Audio Generator	Anritsu	MG443B	M70150	Apr. 01, 09	Apr. 30, 10
2	Attenuator (20dB)	Aeroflex/Wenshel	66-20-34	BY4537	Mar. 30, 09	Mar. 31, 10
3	Attenuator (30dB)	Weinschel	WA-29-30-34	8924	May. 15, 09	May. 31, 10
4	Combiner	Anritsu	Z-164A	M89549	Oct. 09, 08	Oct. 31, 09
5	Modulation Analyzer	Hewlett Packard	8901B	3403A04852	Jul. 08, 09	Jul. 31, 10
6	Spectrum Analyzer	Agilent	E4407B	MY45102460	Feb. 09, 09	Feb. 28, 10
7	Digital Multi Meter	Agilent	34401A	3146A08906	Dec. 17, 08	Dec. 31, 09
8	DC Power Supply	Daiichi denpa kogyo	GZV4000	90290932	None	None

Measuring Cables

No.	Cable	Manufacture	Model No.	Serial No.	Cal Date	Cal Exp.
W1	Coaxial Cable	Suhner	SUCOFLEX104	KSR00091	May. 15, 09	May. 31, 10
W3	Coaxial Cable	Suhner	SUCOFLEX104	KSR00042	Mar. 12, 09	Mar. 31, 10
W4	Coaxial Cable	Pacific custom	RG-58 C/U	AM90C03	Jan. 14, 09	Jan. 31, 10
W6	Balance Cable	Nicoon	3D-2V	KSR00092	Oct. 09, 08	Oct. 31, 09

Measuring Equipment Configuration

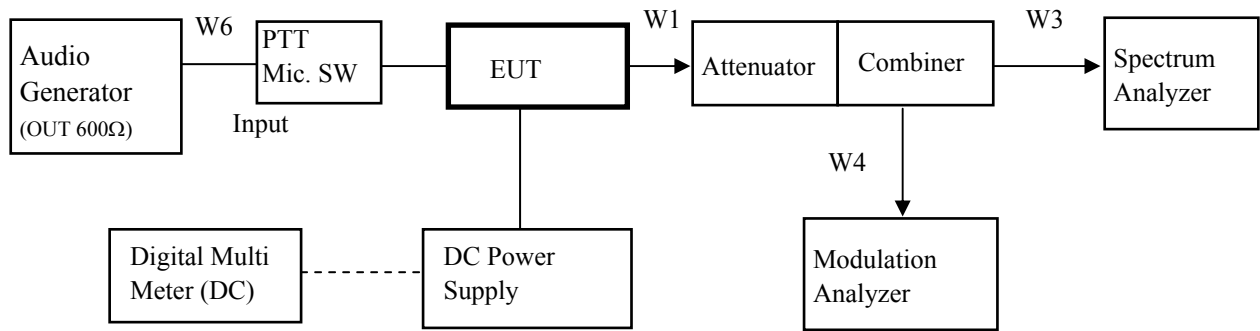

Test Results

Test date	Aug 18, 2009	
Location	Kashima No.1 Test Site	
temperature	23.9 to 26.8	[degree C]
Humidity Variation	46 to 52	[%]
Atmospheric Pressure	101.4 to 101.6	[kPa]
Test Engineer	Koichi Wagatsuma	

Test was carried out for all the frequency band of section 10.1

State the worst case (below).

State : High Power / Authorized Bandwidth 20 kHz:FM / 438.05 MHz(CFR)

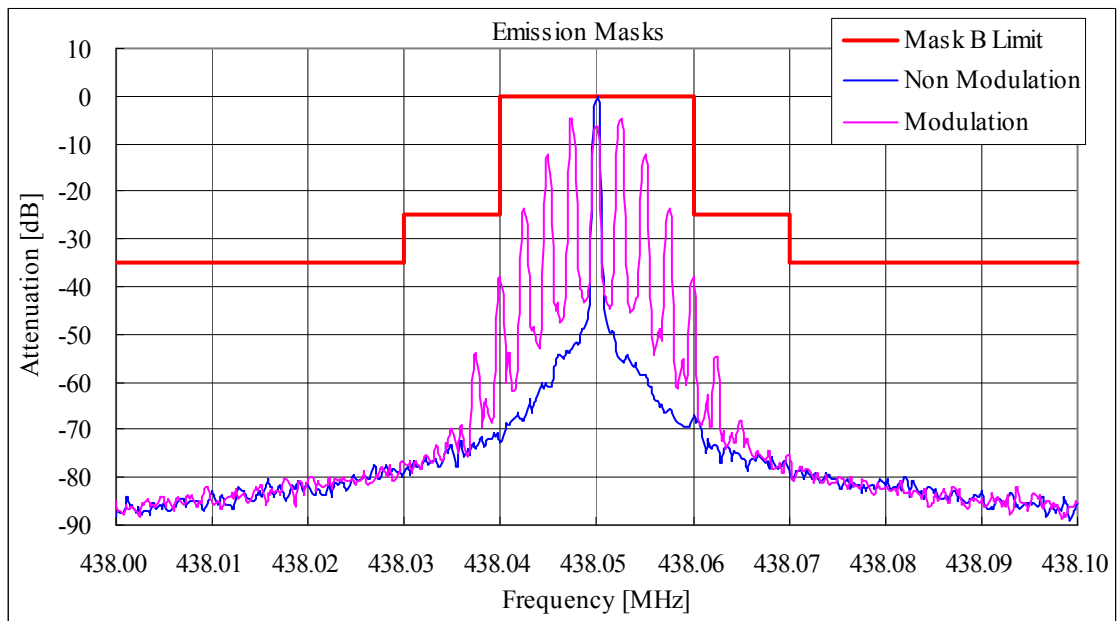

State : High Power / Authorized Bandwidth 11.25 kHz:FM / 406.15 MHz(CFR)

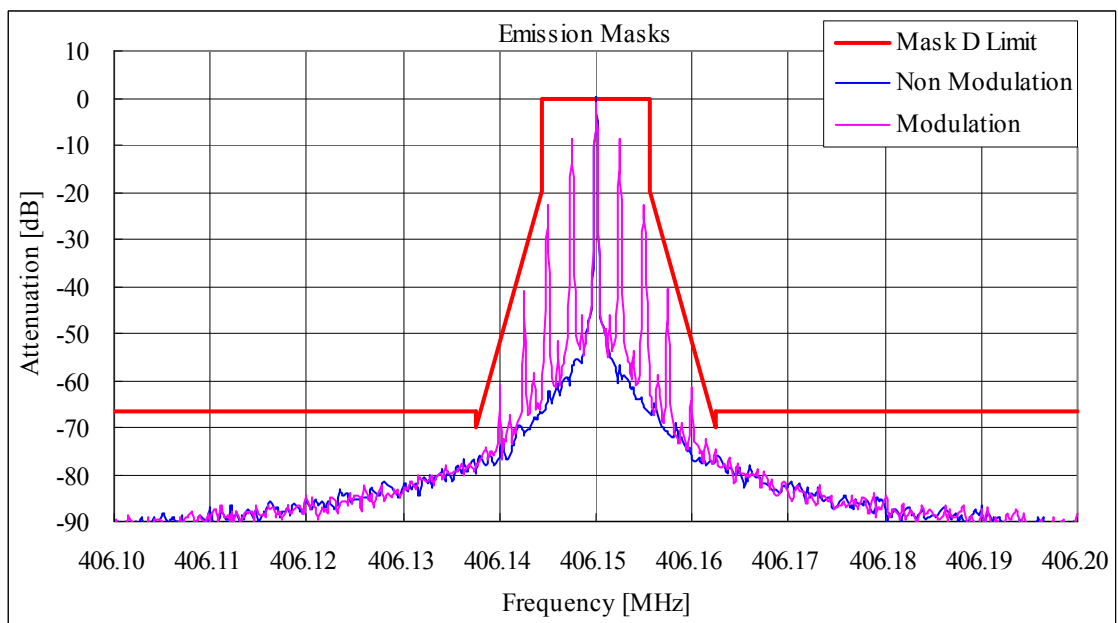

State : Low Power / Authorized Bandwidth 20 kHz:FM / 438.05 MHz(CFR)

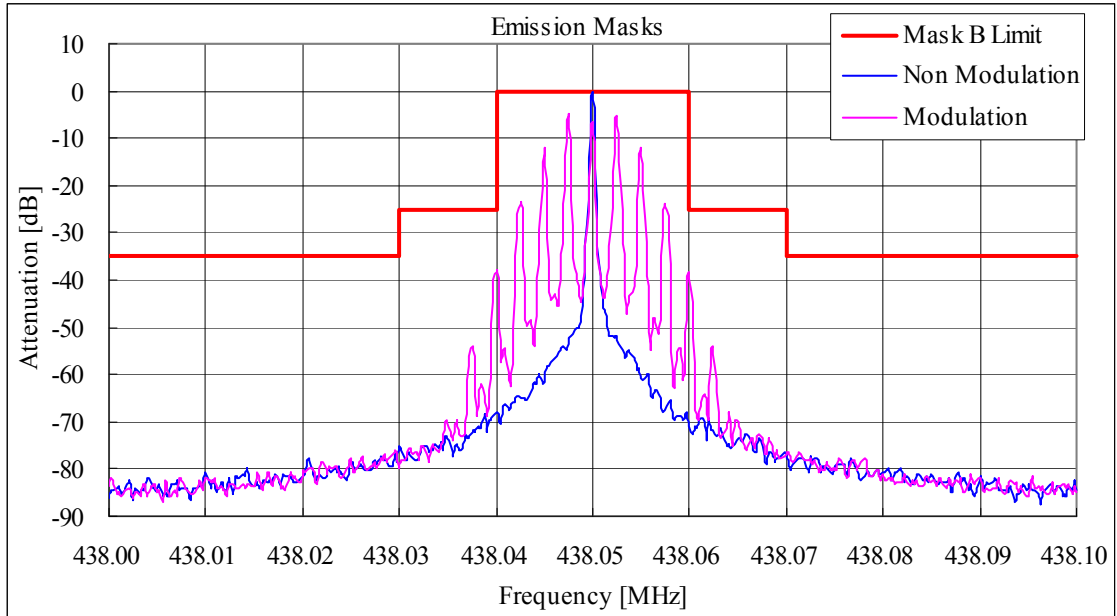

State : Low Power / Authorized Bandwidth 11.25 kHz:FM / 406.15 MHz(CFR)

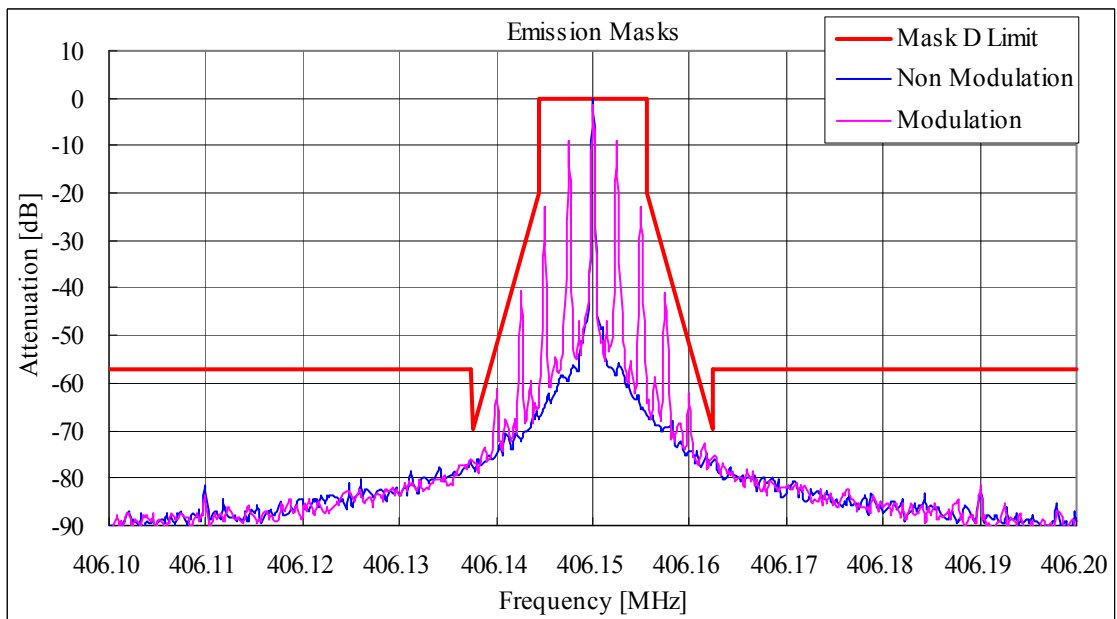

State : High Power / Authorized Bandwidth 20 kHz:FM / 428.05 MHz(RSS)

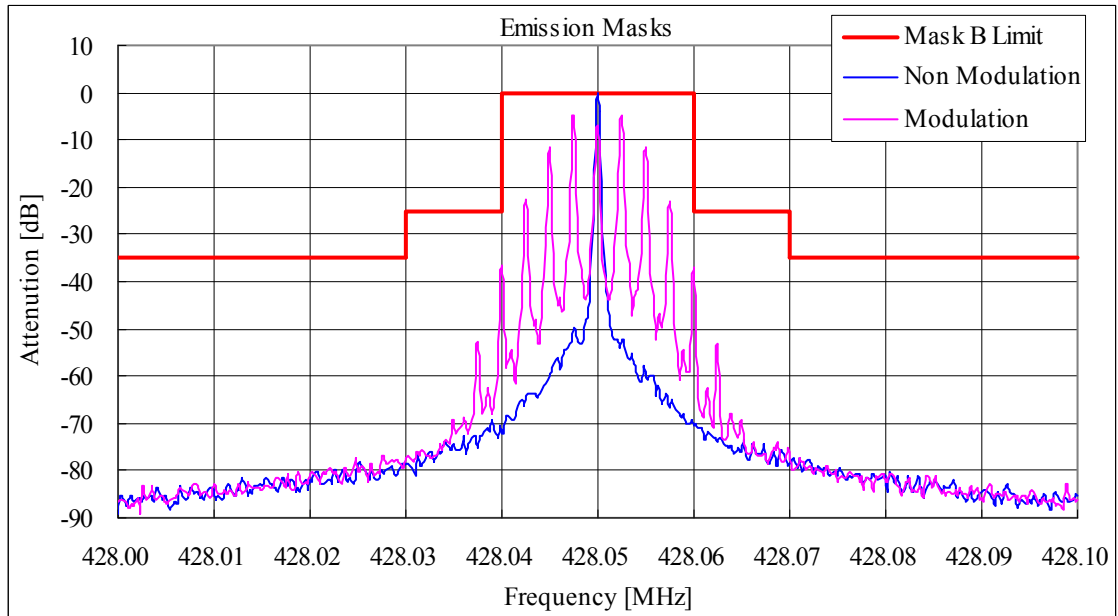

State : High Power / Authorized Bandwidth 11.25 kHz:FM / 428.05 MHz(RSS)

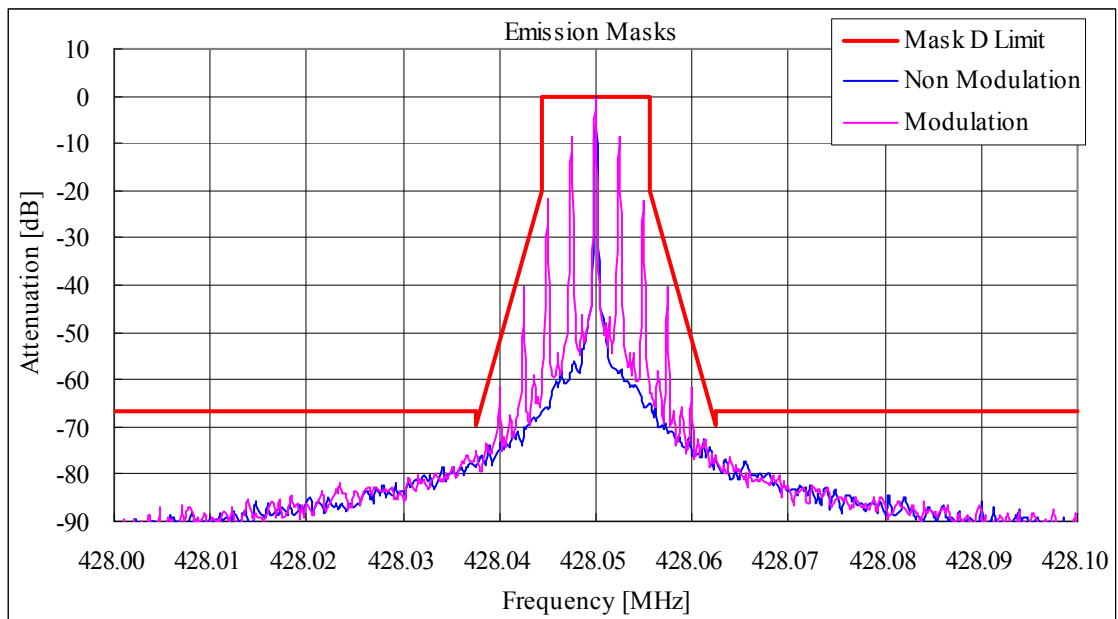

State : Low Power / Authorized Bandwidth 20 kHz:FM / 428.05 MHz(RSS)

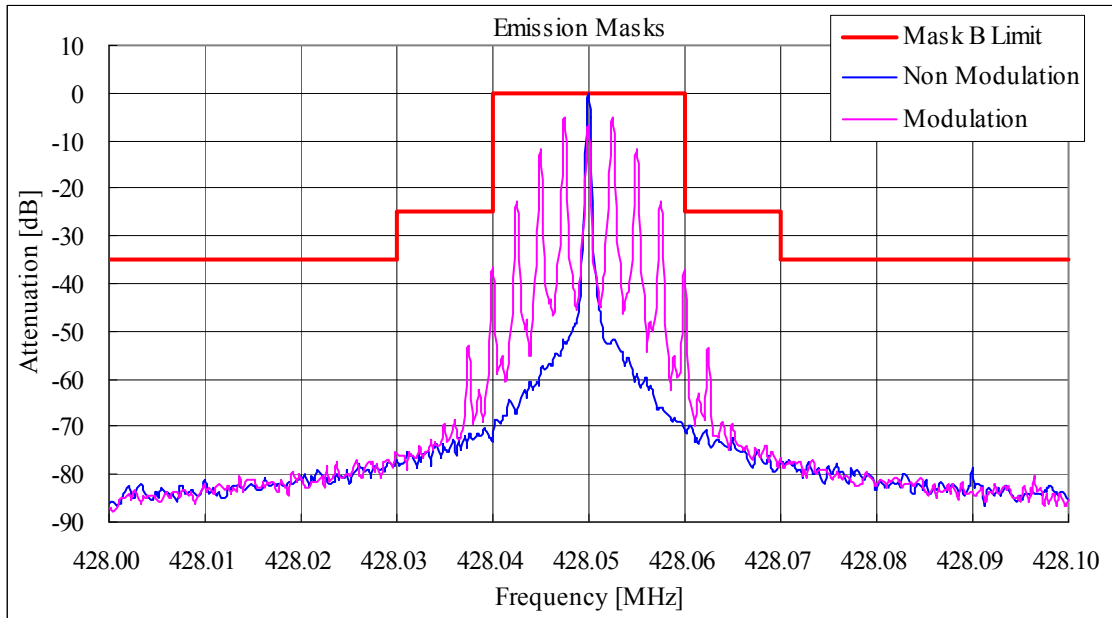

State : Low Power / Authorized Bandwidth 11.25 kHz:FM / 428.05 MHz(RSS)

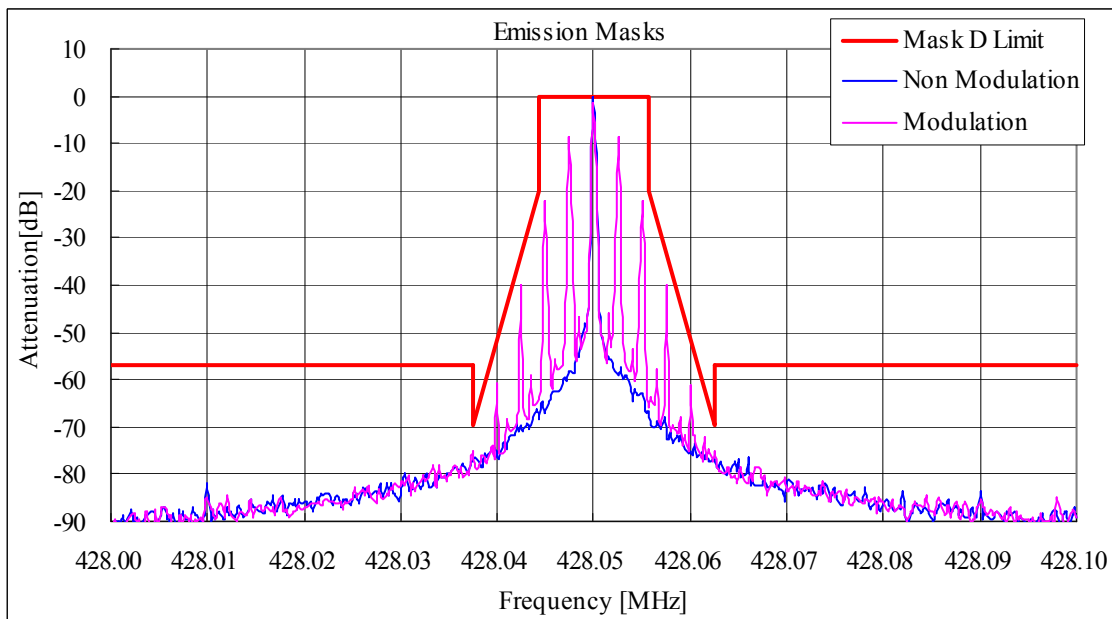

10.5 Transient Frequency Behavior

REGULATIONS	: 47 CFR 90.214 / RSS-119 Section 5.9
TEST METHOD/GUIDE	: ANSI/TIA-603-C Section 2.2.19.3

Test Procedure

- 1 The EUT and test equipment were set up as shown on the following page.
- 2 The transmitter was turned on.
- 3 The transmitter carrier level was measured at the output of the combiner .
- 4 The transmitter was turned off.
- 5 An RF signal generator (1) modulated with a 1 kHz tone at either 25 kHz or 12.5 kHz or 6.25 kHz deviation, and set to the same frequency as the assigned transmitter frequency, (2) was adjusted to a level -30 dB below the level recorded in Procedure 3, as measured at the output of the combiner.
This level was then fixed for the remainder of the test and is recorded at step h.
- 6 The oscilloscope was setup using TIA-603C steps j and k as a guide, and to 10 msec./div.
- 7 The transmitter was turned on, and the level of the carrier at the output of the combiner was recorded as step l.
- 8 The carrier on-time as referenced in TIA-603-C steps m, n, and o was captured and plotted.
- 9 The carrier off-time as referenced in TIA-603-C steps p, q, r, and s was captured and plotted.

No.	Equipment	Manufacture	Model No.	Serial No.	Cal Date	Cal Exp.
1	Signal Generator	Rohde&Schwarz	SMT06	100684	Dec. 12, 08	Dec. 31, 09
2	Oscilloscope	Tektronix	TDS 680B	B010292	Oct. 14, 08	Oct. 31, 09
3	Power Meter	Hewlett Packard	E4418B	GB38410265	May 26, 09	May. 31, 10
4	Power Sensor	Hewlett Packard	8482A	US37292237	May 26, 09	May. 31, 10
5	Attenuator (20dB)	Aeroflex/Wenshel	66-20-34	BY4537	Mar. 30, 09	Mar. 31, 10
6	Attenuator (30dB)	Weinschel	WA-29-30-34	8924	May. 15, 09	May. 31, 10
7	Modulation Analyzer	Hewlett Packard	8901B	3403A04852	Jul. 08, 09	Jul. 31, 10
8	Combiner(1)	Anritsu	Z-164A	M89549	Oct. 09, 08	Oct. 31, 09
9	Combiner(2)	Anritsu	Z-164A	M89249	Oct. 09, 08	Oct. 31, 09
10	Attenuator (3dB)	TME	CFA-20NPJ-3	679701	May. 15, 09	May. 31, 10
11	Digital Multi Meter	Agilent	34401A	3146A08906	Dec. 17, 08	Dec. 31, 09
12	DC Power Supply	Daichi denpa kogyo	GZV4000	90290932	None	None

Measuring Cables

No.	Cable	Manufacture	Model No.	Serial No.	Cal Date	Cal Exp.
W1	Coaxial Cable	Suhner	SUCOFLEX104	KSR00091	May. 15, 09	May. 31, 10
W4	Coaxial Cable	Pacific custom	RG-58 C/U	AM90C02	Jan. 14, 09	Jan. 31, 10
W5	Coaxial Cable	Pacific custom	RG-58 C/U	AM90C03	Jan. 14, 09	Jan. 31, 10
W9	Coaxial Cable	Pacific custom	RG-58 C/U	KSR00094	Oct. 09, 08	Oct. 31, 09
W10	Coaxial Cable	Pacific custom	RG-58 C/U	KSR00095	Oct. 09, 08	Oct. 31, 09
W12	Coaxial Cable	Pacific custom	RG-58 C/U	AM90C04	Jan. 14, 09	Jan. 31, 10

Measuring Equipment Configuration

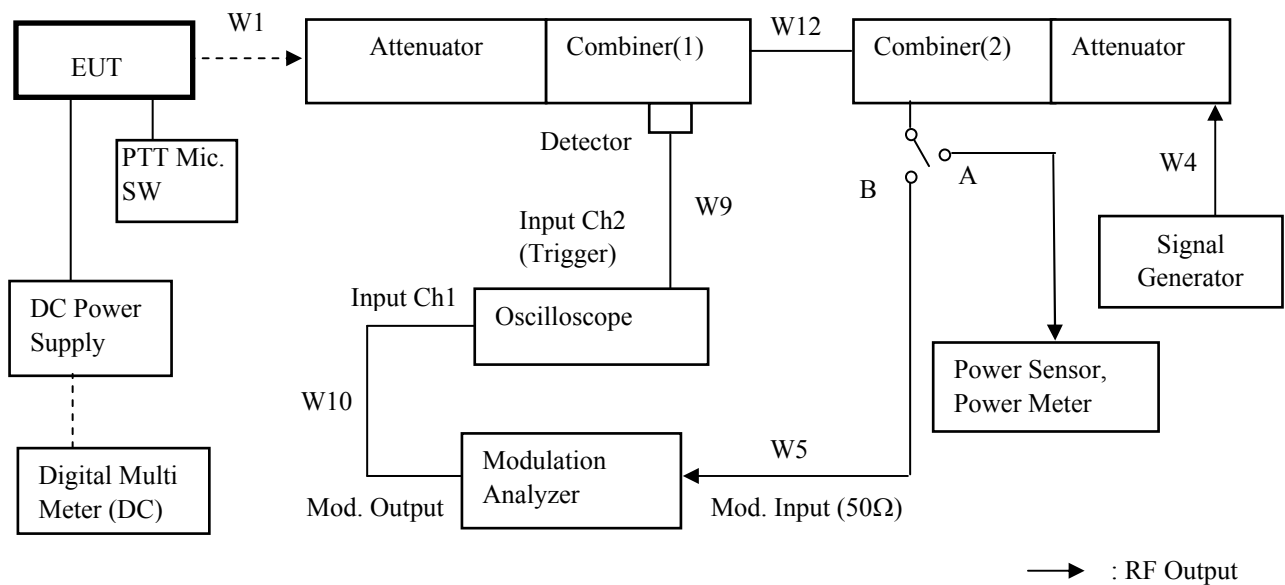

Test Results

Test date	Aug 19, 2009	
Location	Kashima No.1 Test Site	
temperature	23.6 to 26.1	[degree C]
Humidity Variation	45 to 52	[%]
Atmospheric Pressure	101.3 to 101.6	[kPa]
Test Engineer	Koichi Wagatsuma	

Test was carried out for all the frequency band of section 10.1

State the worst case (below).

State : High Power / Authorized Bandwidth 20 kHz / 469.95 MHz(CFR / RSS) / PTT:OFF -ON

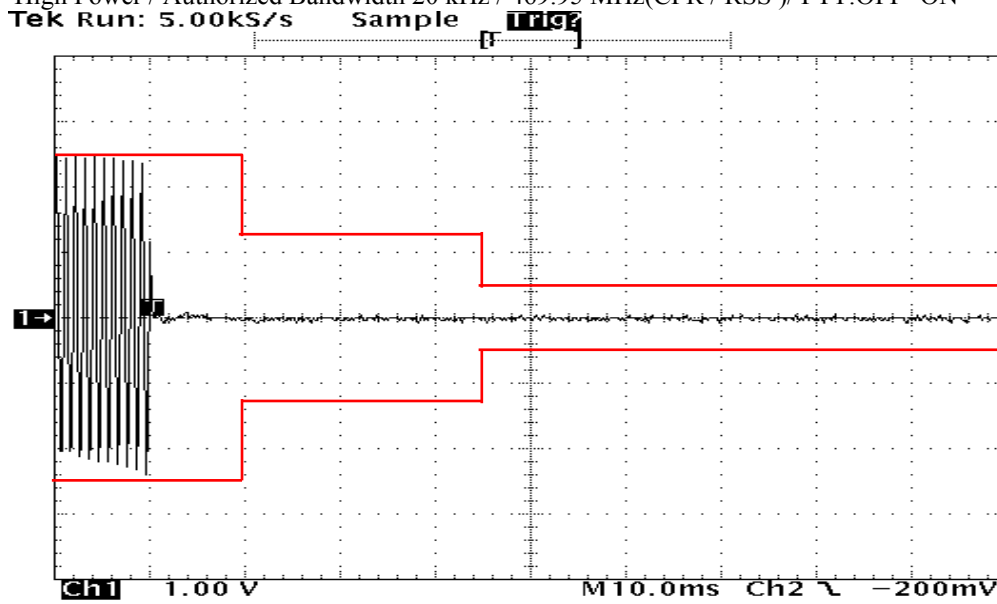

State : High Power / Authorized Bandwidth 20 kHz / 469.95 MHz(CFR / RSS) / PTT:ON -OFF

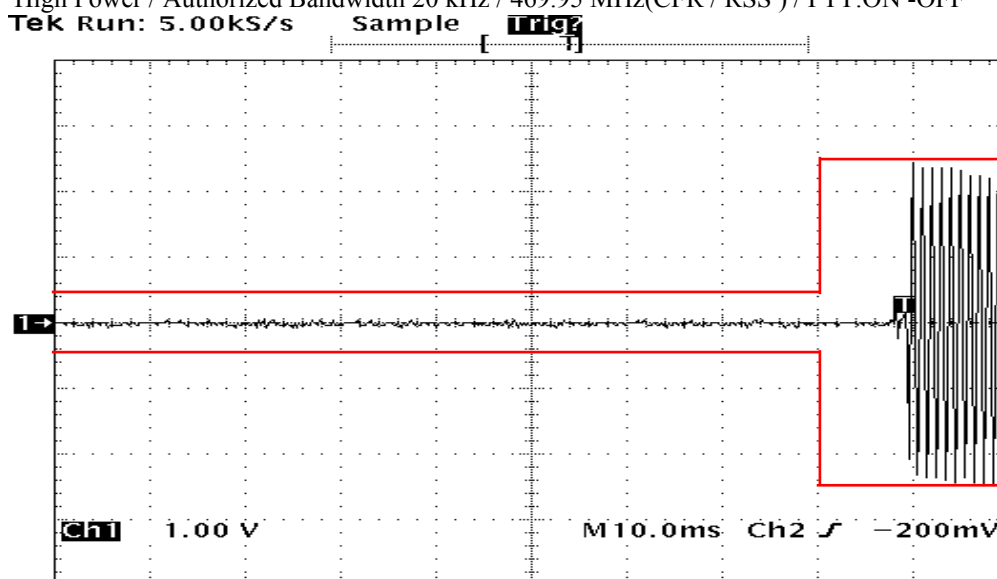

State : High Power / Authorized Bandwidth 11.25 kHz / 469.95 MHz(CFR / RSS) / PTT:OFF -ON

Tek Run: 5.00kS/s Sample **Trigger**

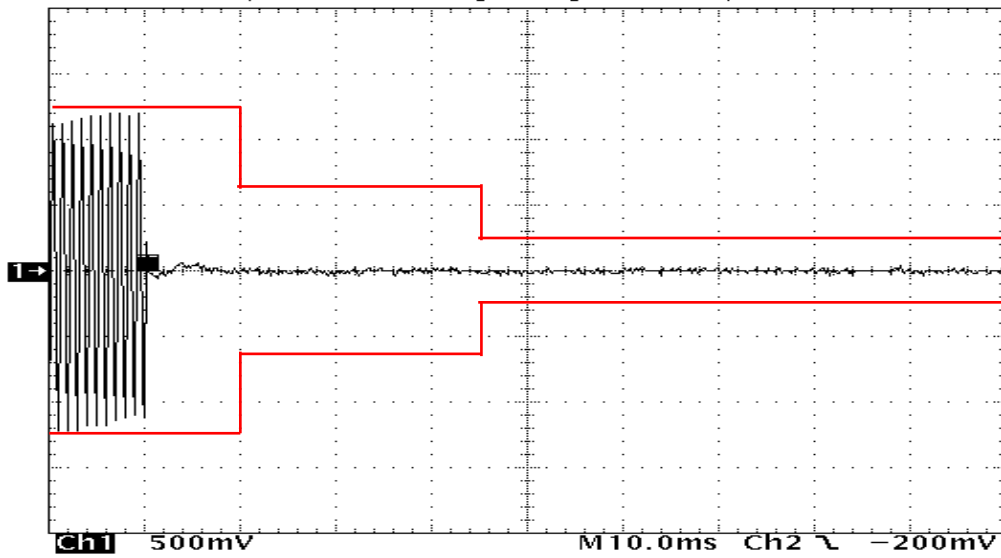

State : High Power / Authorized Bandwidth 11.25 kHz / 469.95 MHz(CFR / RSS) / PTT:ON -OFF

Tek Run: 5.00kS/s Sample **Trigger**

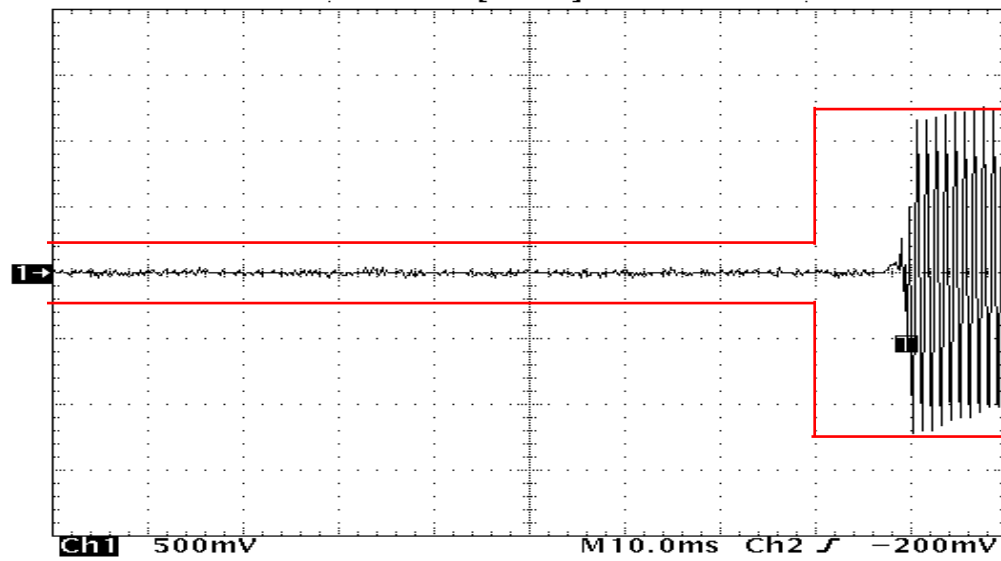

10.6 Audio Frequency Response / Audio Low Pass Filter (Voice Input)

REGULATIONS : 47 CFR 2.1047 (a) / RSS-119 Section 5.10

TEST METHOD/GUIDE : ANSI/TIA-603-C Section 2.2.6.2.2, 3.2.6.2 / RSS-119 Section 4.3

Test Procedure

- 1 The EUT and test equipment were set up as shown on the following page.
- 2 Adjust the Modulation Analyzer for the following setting:
 - a) High-pass filter : 50 Hz
 - b) Low-pass filter : 15 kHz
 - c) Detector : positive peak
 - d) Function : FM
- 3 The audio signal input was adjusted to obtain 20 % modulation at 1 kHz, and this point was taken as the 0 dB reference level.
- 4 With input levels held constant and below limiting at all frequencies, the audio signal generator was varied from 300 Hz to 5 kHz.
- 5 The response in dB relative to 1 kHz was then measured, using the Modulation Analyzer.

Measuring Equipments

No.	Equipment	Manufacture	Model No.	Serial No.	Cal Date	Cal Exp.
1	Audio Generator	Anritsu	MG443B	M70150	Apr. 01, 09	Apr. 30, 10
2	Audio Analyzer	Hewlett Packard	8903B	2818A04372	Apr. 10, 09	Apr. 30, 10
3	Attenuator (20dB)	Aeroflex/Wenshel	66-20-34	BY4537	Mar. 30, 09	Mar. 31, 10
4	Attenuator (30dB)	Weinschel	WA-29-30-34	8924	May. 15, 09	May. 31, 10
5	Modulation Analyzer	Hewlett Packard	8901B	3403A04852	Jul. 08, 09	Jul. 31, 10
6	Digital Multi Meter	Agilent	34401A	3146A08906	Dec. 17, 08	Dec. 31, 09
7	DC Power Supply	Daiichi denpa kogyo	GZV4000	90290932	None	None

Measuring Cables

No.	Cable	Manufacture	Model No.	Serial No.	Cal Date	Cal Exp.
W1	Coaxial Cable	Suhner	SUCOFLEX104	KSR00091	May. 15, 09	May. 31, 10
W4	Coaxial Cable	Pacific custom	RG-58 C/U	AM90C03	Jan. 14, 09	Jan. 31, 10
W6	Balance Cable	Nicoon	3D-2V	KSR00092	Oct. 09, 08	Oct. 31, 09
W9	Coaxial Cable	Pacific custom	RG-58 C/U	KSR00094	Oct. 09, 08	Oct. 31, 09

Measuring Equipment Configuration

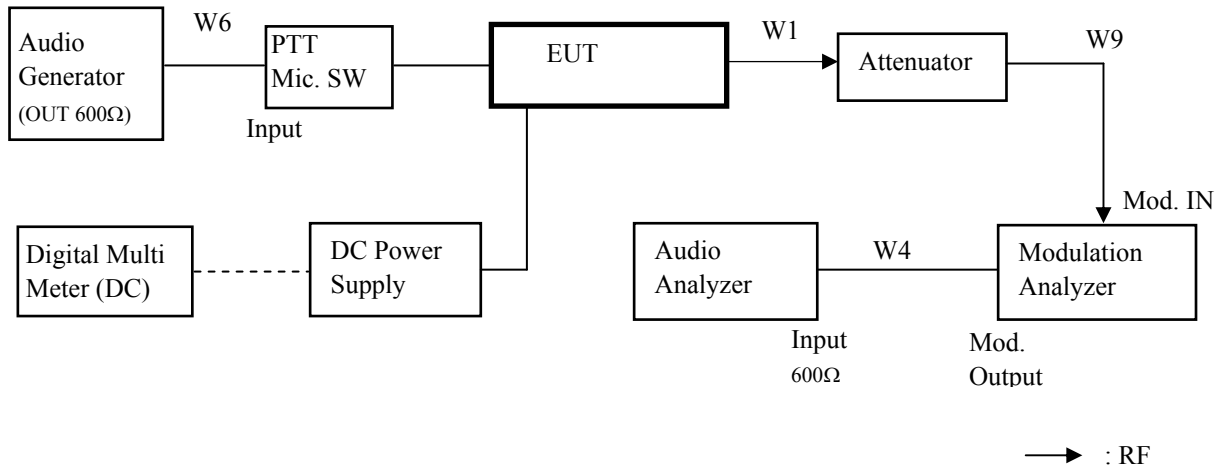

Test Results

Test date	Aug 17, 2009	
Location	Kashima No.1 Test Site	
temperature	24 to 26.4	[degree C]
Humidity Variation	46 to 60	[%]
Atmospheric Pressure	101.4to 101.6	[kPa]
Test Engineer	Koichi Wagatsuma	

Test was carried out for all the frequency band of section 10.1
 State the worst case (below).

State : High Power / Authorized Bandwidth 20 kHz / 406.15 MHz (CFR / RSS)

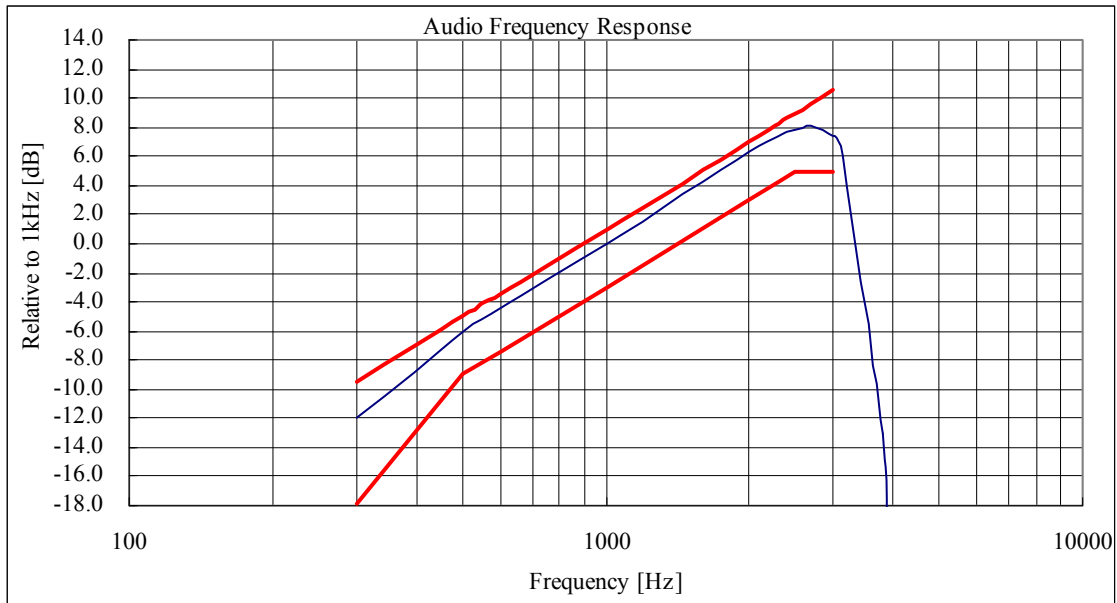

State : High Power / Authorized Bandwidth 11.25 kHz / 406.15 MHz (CFR / RSS)

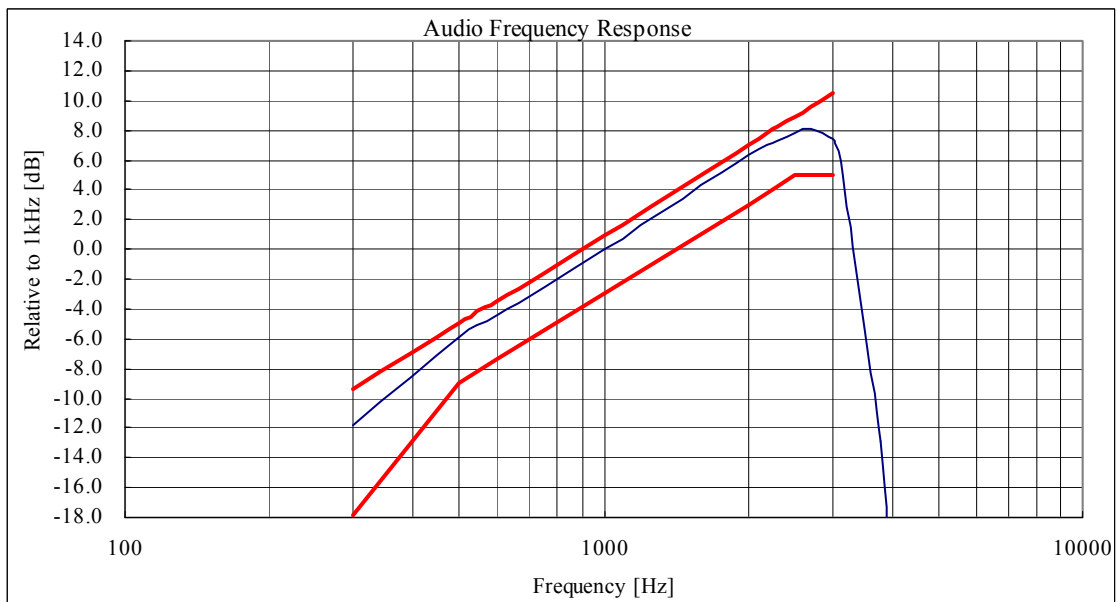

Note:

Audio Filter of the above result is substituted with the same structure as Audio Frequency Resonse.
 On the transmission condition below 3kHz, Transceiver shows pre-emphasis condition of transmission function.
 On the transmission condition above 3kHz, Transceiver shows Audio Low Pass Filter.

10.7 Modulation Limiting

REGULATIONS	: 47 CFR 2.1047 (b) / RSS-119 Section 5.10
TEST METHOD/GUIDE	: ANSI/TIA-603-C Section 2.2.3.2, 1.3.4.4 / RSS-119 Section 4.3

Test Procedure

- 1 The EUT and test equipment were set up as shown on the following page.
- 2 Adjust the Modulation Analyzer for the following setting:
 - a) High-pass filter : off
 - b) Low-pass filter : 15 kHz
 - c) Detector : positive peak
 - d) Function : FM
- 3 Apply a 1kHz modulation signal to the transmitter from the audio generator, and adjust the level to obtain 60% of full rated system deviation.
- 4 Measure the modulation frequency that was showed on the Modulation Analyzer when the output levels of the Audio Generator were changed from -20 dB to +50 dB by 10 dB.
- 5 Set the output frequencies of the Audio Generator 300 Hz and 3 kHz, and repeat test procedure 4.
- 6 Set the the Detector of the Modulation Analyzer Negative Peak.
- 7 Repeat test procedure 4 and 5.

Measuring Equipments

No.	Equipment	Manufacture	Model No.	Serial No.	Cal Date	Cal Exp.
1	Audio Generator	Anritsu	MG443B	M70150	Apr. 01, 09	Apr. 30, 10
2	Attenuator (20dB)	Aeroflex/Wenshel	66-20-34	BY4537	Mar. 30, 09	Mar. 31, 10
3	Attenuator (30dB)	Weinschel	WA-29-30-34	8924	May. 15, 09	May. 31, 10
4	Modulation Analyzer	Hewlett Packard	8901B	3403A04852	Jul. 08, 09	Jul. 31, 10
5	Digital Multi Meter	Agilent	34401A	3146A08906	Dec. 17, 08	Dec. 31, 09
6	DC Power Supply	Daiichi denpa kogyo	GZV4000	90290932	None	None

Measuring Cables

No.	Cable	Manufacture	Model No.	Serial No.	Cal Date	Cal Exp.
W1	Coaxial Cable	Suhner	SUCOFLEX104	KSR00091	May. 15, 09	May. 31, 10
W4	Coaxial Cable	Pacific custom	RG-58 C/U	AM90C03	Jan. 14, 09	Jan. 31, 10
W6	Balance Cable	Nicoon	3D-2V	KSR00092	Oct. 09, 08	Oct. 31, 09

Measuring Equipment Configuration

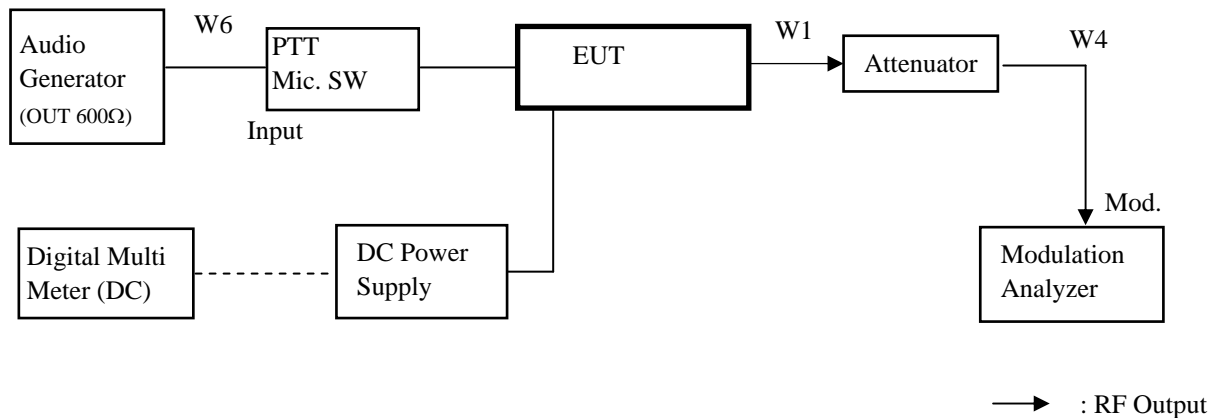

Test Results

Test date	Aug 17, 2009	
Location	Kashima No.1 Test Site	
temperature	24 to 26.4	[degree C]
Humidity Variation	46 to 60	[%]
Atmospheric Pressure	101.4to 101.6	[kPa]
Test Engineer	Koichi Wagatsuma	

Test was carried out for all the frequency band of section 10.1
 State the worst case (below).

State : High Power / Authorized Bandwidth 20 kHz / 469.95 MHz (CFR / RSS)

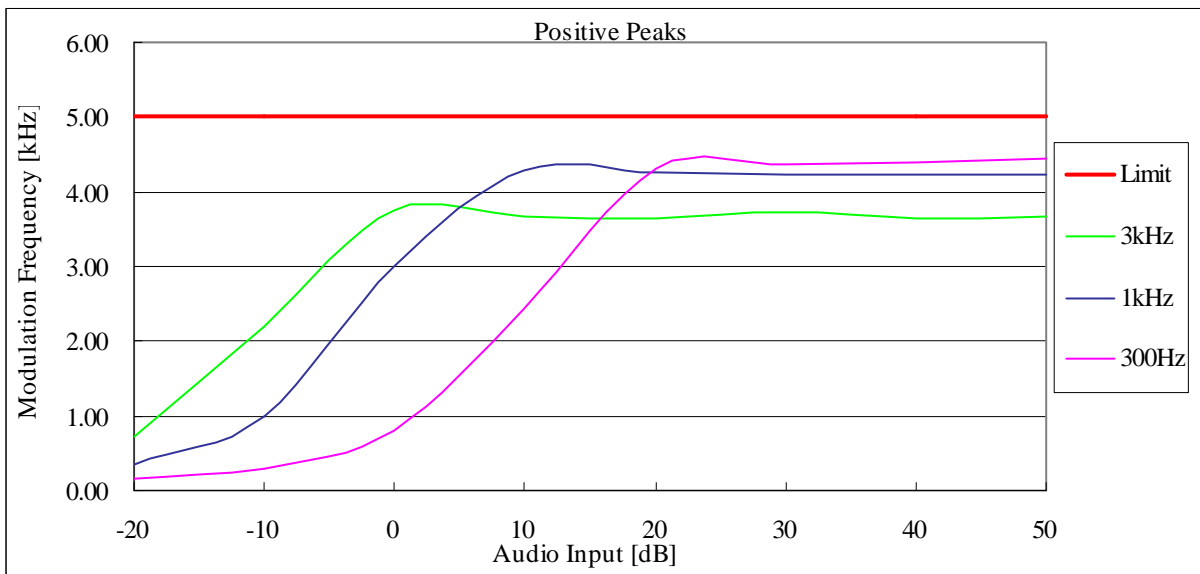

State : High Power / Authorized Bandwidth 20 kHz / 469.95 MHz (CFR / RSS)

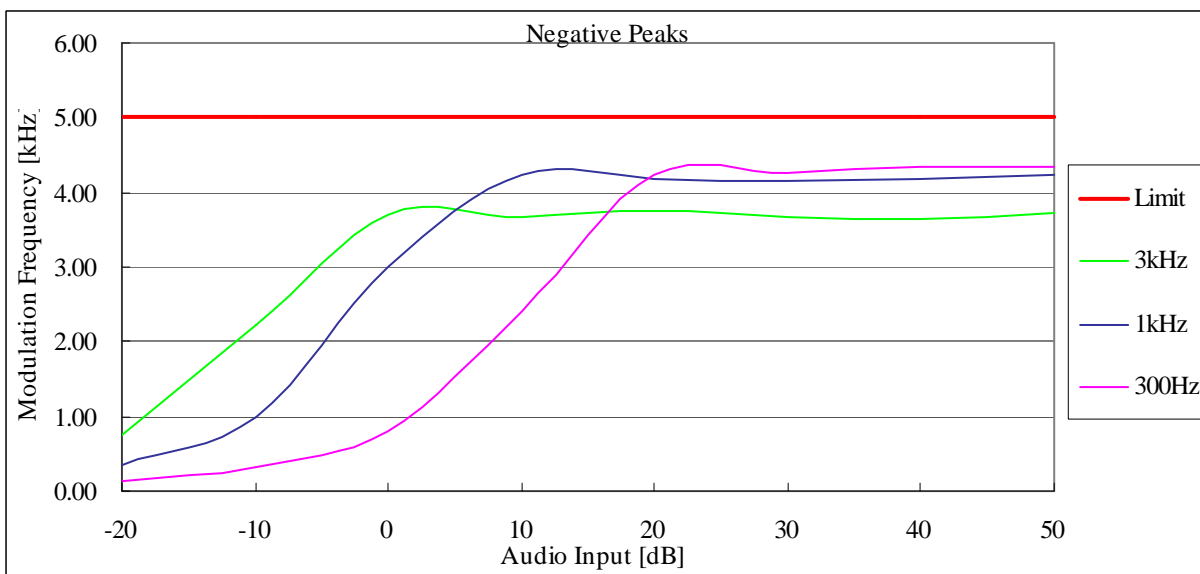

State : High Power / Authorized Bandwidth 11.25 kHz / 469.95 MHz (CFR / RSS)

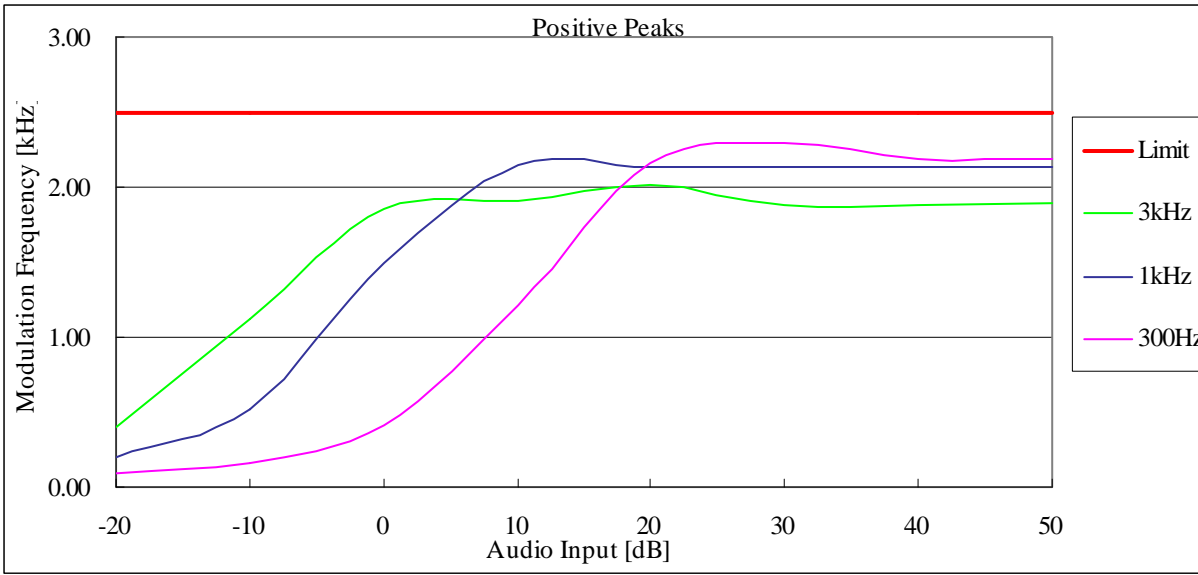

State : High Power / Authorized Bandwidth 11.25 kHz / 469.95 MHz (CFR / RSS)

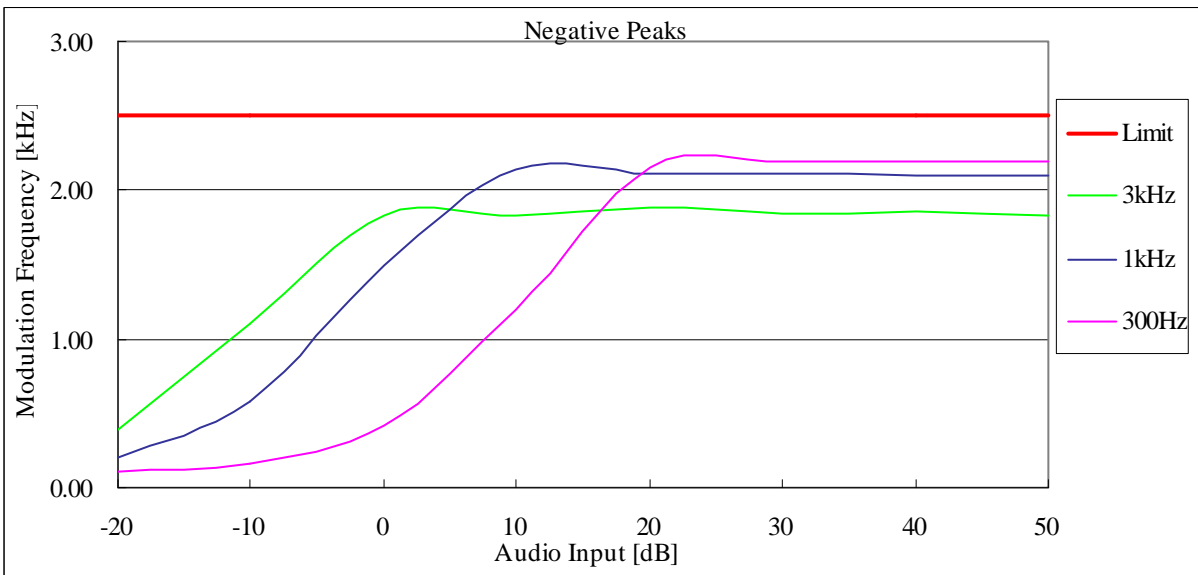

10.8 Frequency Stability (Temperature Variation)

REGULATIONS : 47 CFR 2.1055 (a) (1), 22.355 , 74.464 , 90.213(a) / RSS-119 Section 5.3

TEST METHOD/GUIDE : ANSI/TIA-603-C Section 2.2.2.2 / RSS-Gen Section 4.7(a)

Test Procedure

- 1 The EUT and test equipment were set up as shown on the following page.
- 2 Set the temperature -30 degrees C.
- 3 Leave the EUT for 1 hour after it became the temperature that was set up.
- 4 Make the EUT the transmitting state.
Two minutes later, measure the output frequency.
- 5 Make the EUT the receiving state.
- 6 Set the temperature 50 degrees C by 10 degrees C.
And repeat test procedure 3 to 5.

Measuring Equipments

No.	Equipment	Manufacture	Model No.	Serial No.	Cal Date	Cal Exp.
1	Attenuator (30dB)	Weinschel	WA-29-30-34	8923	May. 15, 09	May. 31, 10
2	Attenuator (20dB)	Aeroflex/Wenshel	66-20-34	BY4537	Mar. 30, 09	Mar. 31, 10
3	Spectrum Analyzer	Agilent	E7403A	MY42000067	Feb. 03, 09	Feb. 28, 10
4	Digital Multi Meter	FLUKE	8846A	9642018	Jul. 06, 09	Jul. 31, 10
5	DC Power Supply	Micky	10A	None	None	None
6	DC Power Supply	Daiichi denpa kogyo	GZV4000	90290931	None	None
7	Temperature Chamber	Tabai	PL-3F	5103661	None	None
8	Temperature Meter	Sato	PC-5000TRH-II	A11999972	Apr. 10, 09	Apr. 30, 10

Measuring Cables

No.	Cable	Manufacture	Model No.	Serial No.	Cal Date	Cal Exp.
W2	Coaxial Cable	Suhner	SUCOFLEX104	KSR00211	Aug. 11, 09	Aug. 31, 10
W3	Coaxial Cable	Suhner	SUCOFLEX104	KSR00042	Mar. 12, 09	Mar. 31, 10

Measuring Equipment Configuration

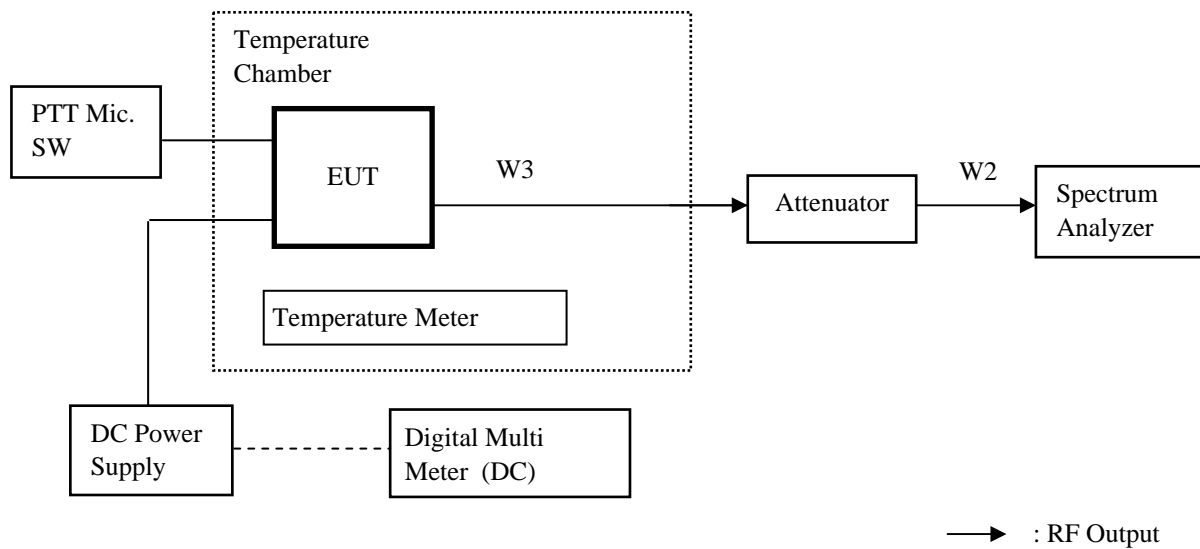

Test Results

Test date	Aug 25, 2009 to Aug 26, 2009
Location	Kashima No.1 Test Site
Test Engineer	Koichi Wagatsuma

Test was carried out for all the frequency band of section 10.1

State the worst case (below).

State : High Power / Authorized Bandwidth 20 kHz / 469.95 MHz (CFR / RSS)

Reference Frequency: 469.950000 MHz(CFR Stability)

469.949889 MHz(RSS Stability)

No.	Temperature (Degree C)	Frequency (MHz)	CFR Stability (ppm)	RSS Stability (ppm)	Limit (+/- ppm)	Min. Margin (ppm)
1	-30	469.949739	-0.56	-0.32	2.5	1.94
2	-20	469.949719	-0.60	-0.36	2.5	1.90
3	-10	469.949727	-0.58	-0.34	2.5	1.92
4	0	469.949820	-0.38	-0.15	2.5	2.12
5	10	469.949896	-0.22	0.01	2.5	2.28
6	20	469.949889	-0.24	0.00	2.5	2.26
7	30	469.949855	-0.31	-0.07	2.5	2.19
8	40	469.949738	-0.56	-0.32	2.5	1.94
9	50	469.949618	-0.81	-0.58	2.5	1.69

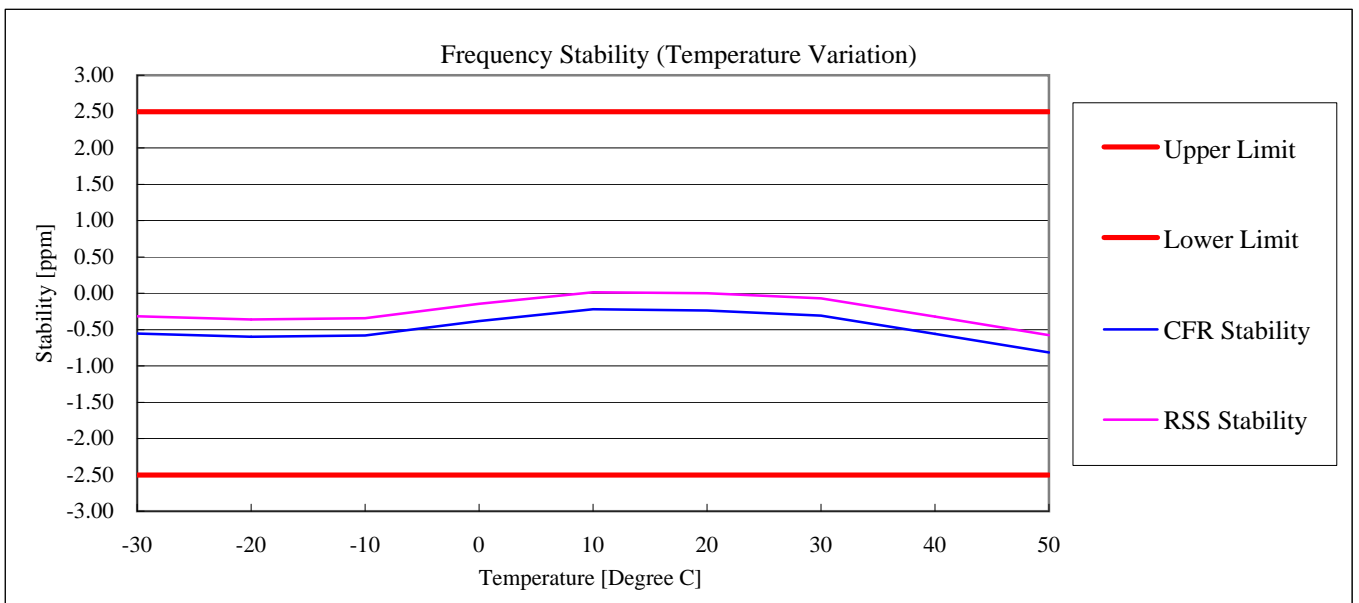

10.9 Frequency Stability (Voltage Variation)

REGULATIONS : 47 CFR 2.1055 (d) (1), 22.355 , 74.464 , 90.213(a)

TEST METHOD/GUIDE : ANSI/TIA-603-C Section 2.2.2.2

Test Procedure

- 1 The EUT and test equipment were set up as shown on the following page.
- 2 The power supply voltage to the EUT was varied from 85 % to 115 % of the nominal value measured at the input to the EUT.

Measuring Equipments

No.	Equipment	Manufacture	Model No.	Serial No.	Cal Date	Cal Exp.
1	Attenuator (30dB)	Weinschel	WA-29-30-34	8923	May. 15, 09	May. 31, 10
2	Attenuator (20dB)	Aeroflex/Wenshel	66-20-34	BY4537	Mar. 30, 09	Mar. 31, 10
3	Spectrum Analyzer	Agilent	E7403A	MY42000067	Feb. 03, 09	Feb. 28, 10
4	Digital Multi Meter	FLUKE	8846A	9642018	Jul. 06, 09	Jul. 31, 10
5	DC Power Supply	Micky	10A	None	None	None
6	DC Power Supply	Daiichi denpa kogyo	GZV4000	90290931	None	None
7	Temperature Chamber	Tabai	PL-3F	5103661	None	None
8	Temperature Meter	Sato	PC-5000TRH-II	A11999972	Apr. 10, 09	Apr. 30, 10

Measuring Cables

No.	Cable	Manufacture	Model No.	Serial No.	Cal Date	Cal Exp.
W2	Coaxial Cable	Suhner	SUCOFLEX104	KSR00211	Aug. 11, 09	Aug. 31, 10
W3	Coaxial Cable	Suhner	SUCOFLEX104	KSR00042	Mar. 12, 09	Mar. 31, 10

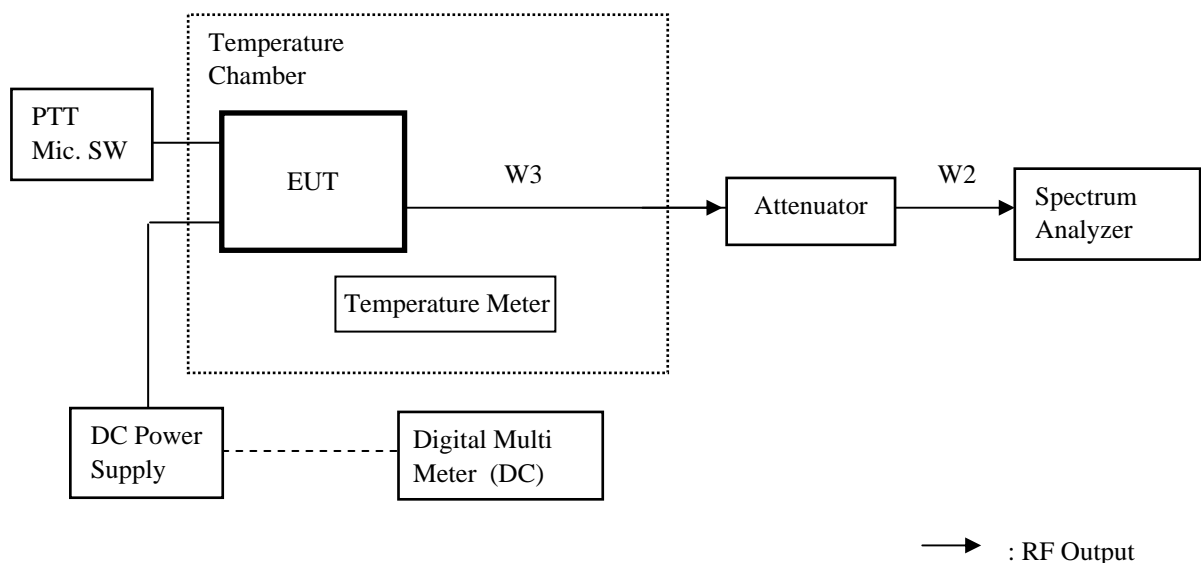
Measuring Equipment Configuration

Test Results

Test date	Aug 24, 2009
Location	Kashima No.1 Test Site
Test Engineer	Koichi Wagatsuma

Test was carried out for all the frequency band of section 10.1
 State the worst case (below).

State : High Power / Authorized Bandwidth 11.25 kHz / 469.95 MHz (CFR / RSS)

No.	Temperature (Degree C)	Diviation (%)	Voltage (V)	Frequency (MHz)	Stability (ppm)	Limit +/- (ppm)	Margin (ppm)
1	20	85	11.56	469.949877	-0.26	2.5	2.24
2	20	100	13.60	469.949873	-0.27	2.5	2.23
3	20	115	15.64	469.949846	-0.33	2.5	2.17

10.10 Receiver Spurious Emissions(Radiated)

REGULATIONS	:	RSS-119 Section 5.11, RSS-Gen Section 6
-------------	---	---

TEST METHOD/GUIDE	:	RSS-Gen Section 4.10
-------------------	---	----------------------

TEST PROCEDURE

- 1 The EUT and test equipment were set up as shown on the following page.
- 2 Tabletop Equipment
EUT is placed on the wooden table, the top of which is 0.8meter above the metal ground plane(turntable).
- 3 Interconnecting Cables
Excess part of the interconnecting cables longer than 1 meter are bundled in the center.
Cables that hang closer than 40 cm to the ground plane is folded back and forth forming bundle 30 to 40 cm long,
- 4 Measuring Instruments
Measuring instruments list and their calibration schedule are shown on Measurement Equipment Configuration.
The brief description are as follows;
- 5 Antennas
The broadband Bi-cog antenna is used for measurement on the frequency range 30 – 1000 MHz.
The Double ridged guide antenna is used for frequency higher than 1000 MHz
- 6 Pre-amplifier
The broadband pre-amplifier is used for radiated emission measurement.
The signal to noise ratio is improved by using pre-amplifier.
- 7 Spectrum Analyzer
The spectrum analyzer is used for preliminary measurement of frequency range 30 – 1000 MHz, and also used for final measurement of higher than 1000 MHz (RBW : 1 MHz).
- 8 EMI Test Receiver
The Quasi-peak detector (IF bandwidth : 120 kHz) built in test receiver is used for final measurement of the frequency 30 – 1000 MHz.
The test receiver is complied with the specification of the CISPR publication 16.
- 9 Turntable
The turntable is capable for EUT weight and rotatable 0 to 360 degree horizontally by remote control in the test room.
- 10 Antenna Mast
The antenna mast is attachable to all antennas described on antenna height is adjustable 1 to 4 meters continuously by remote control at the test room, and antenna polarization is also changed by the remote control.
- 11 Preliminary Measurement
EUT is tested on all operating conditions.
The spectrum analyzer is set max-hold mode and swept during turntable was rotated 0 to 360 degree. Then spectrum chart are plotted out to find the worst emission conditions in configuration, operating mode, or ambient noise notation.

12 Final Measurement

The EUT operated in the condition where maximum emission is found in the preliminary test.

The turntable azimuth(EUT direction) and antenna height are adjusted the position so that maximum field strength is obtained for each frequency spectrum to be measured.

The equipment and cables are arranged or manipulated within the range of the test standard in the above condition.

When the uncertain result was obtained, the measurement is retried by using the half wave dipole antenna instead of the broadband antenna

TEST EQUIPMENTS

No.	Equipment	Manufacture	Model No.	Serial No.	Cal Date	Cal Exp.
1	Tri-log Antenna	Schwarzbeck	VULB9168	218	Mar. 05, 09	Mar. 31, 10
2	D.R.G Antenna	EMCO	3115	9903-5699	Apr. 28, 09	Apr. 30, 10
3	Pre-Amplifier	Hewlett Packard	8449B	3008A01182	Apr. 22, 09	Apr. 30, 10
4	Pre-Amplifier	Hewlett Packard	8447D	2727A05324	May. 20, 09	May. 31, 10
5	Attenuator(6dB)	TAMAGAWA	CFA-01(NPJ-6)	None	May. 20, 09	May. 31, 10
6	Attenuator(6dB)	Hewlett Packard	8493C	18493	Apr. 22, 09	Apr. 30, 10
7	Step Attenuator	Hewlett Packard	8494B	2805A14563	May. 20, 09	May. 31, 10
8	RF Switch	Intertek Japan	ACX-150	None	May 20, 09	May. 31, 10
9	Spectrum Analyzer	Hewlett Packard	8563E	3821A09565	Dec. 18, 08	Dec. 31, 09
10	Test Receiver	Rohde & Schwarz	ESS	842886/013	Jan. 07, 09	Jan. 31, 10
11	Dummy Load	TME	CT-150NP	1138693	Sep. 09, 08	Sep. 30, 09
12	Digital Multi Meter	Agilent	34401A	3146A08906	Dec. 17, 08	Dec. 31, 09
13	DC Power Supply	Daiichi denpa kogyo	GZV4000	90290932	None	None

USED CABLES

No.	Cable	Manufacture	Model No.	Serial No.	Cal Date	Cal Exp.
R1	Coaxial Cable	Intertek Japan	5D-2W	2R1001a	May. 20, 09	May. 31, 10
R2	Coaxial Cable	Intertek Japan	RG-177/U	2R1002	May. 20, 09	May. 31, 10
R3	Coaxial Cable	Intertek Japan	RG-5A/U	2R1003	May. 20, 09	May. 31, 10
R4	Coaxial Cable	Intertek Japan	RG-5A/U	2R1004	May. 20, 09	May. 31, 10
R5	Coaxial Cable	Intertek Japan	5D-2W	2R1005	May. 20, 09	May. 31, 10
R6	Coaxial Cable	Intertek Japan	5D-2W	2R1006	May. 20, 09	May. 31, 10
R7	Coaxial Cable	Intertek Japan	5D-2W	2R1007	May. 20, 09	May. 31, 10
R8	Coaxial Cable	Intertek Japan	5D-2W	2R1008a	May. 20, 09	May. 31, 10
R16	Coaxial Cable	Suhner	SUCOFLEX104	290799/4	Apr. 22, 09	Apr. 30, 10
R17	Coaxial Cable	Suhner	SUCOFLEX104	290800/4	Apr. 22, 09	Apr. 30, 10

MEASUREMENT EQUIPMENT CONFIGURATION

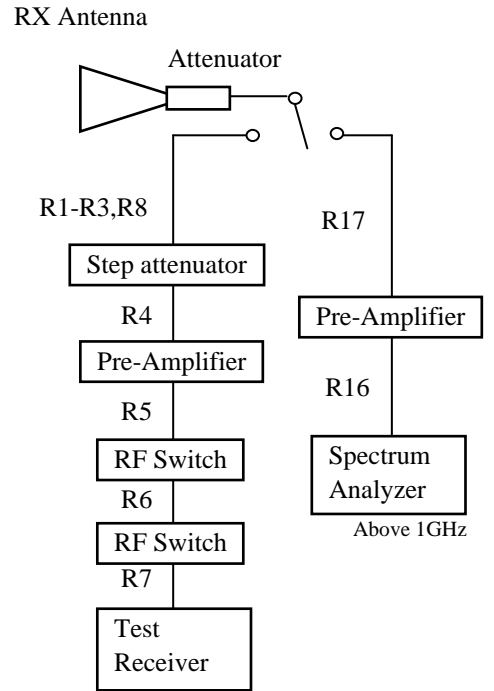
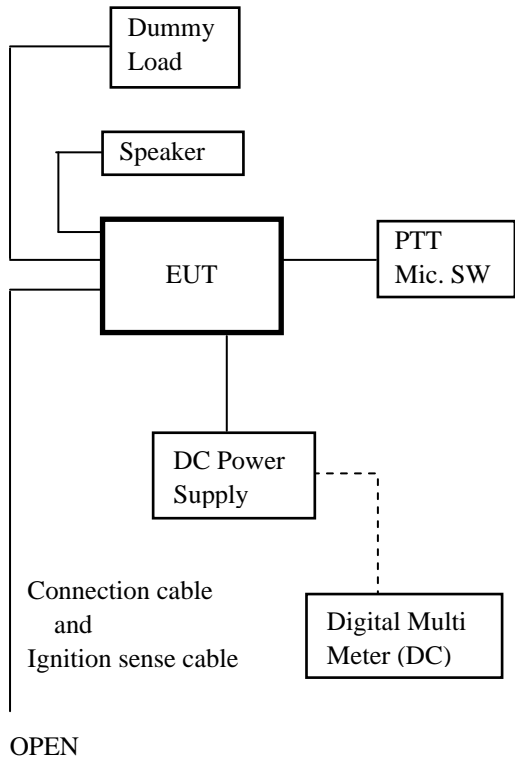

TEST RESULTS

Test date	Aug 20, 2009	
Location	Tochigi No.2 Test Site	
temperature	26	[degree C]
Humidity Variation	46	[%]
Atmospheric Pressure	98.5	[kPa]
Test Engineer	Koichi Wagatsuma	

Test was carried out for the RSS frequency band of section 10.1

State the worst case (below).

State : 469.95 MHz Receiver Condition

No.	Frequency (MHz)	Pol	Mode	Reading Level (dBuv)	Factor* (dB)	Emission Level (dBuV/m)	Limit Level (dBuV/m)	Margin (dB)
1	49.16	Hor.		-	-4.70	-	40.0	-
		Ver.		26.40	-4.70	21.70	40.0	18.3
2	112.97	Hor.		-	-6.80	-	43.5	-
		Ver.		23.10	-6.80	16.30	43.5	27.2
3	115.33	Hor.		-	-6.30	-	43.5	-
		Ver.		24.90	-6.30	18.60	43.5	24.9
4	134.41	Hor.		-	-4.60	-	43.5	-
		Ver.		21.30	-4.60	16.70	43.5	26.8
5	196.64	Hor.		-	-5.70	-	43.5	-
		Ver.		21.20	-5.70	15.50	43.5	28.0
6	431.10	Hor.		43.00	2.40	45.40	46.0	0.6
		Ver.		39.60	2.40	42.00	46.0	4.0
7	862.20	Hor.		26.90	11.50	38.40	46.0	7.6
		Ver.		26.70	11.50	38.20	46.0	7.8
8	1293.27	Hor.	AVG	40.70	-2.40	38.30	54.0	15.7
		Ver.	AVG	39.80	-2.40	37.40	54.0	16.6

There is the margin of 20dB over except for the above points.

* Factor = Antenna, Antenna Pad, Cable, Preamp

Emission Level = Reading Level + Factor

Note:

- 1 Measurement distance is 3 metres.
- 2 Scanned frequency are 30 to 2000 MHz.
- 3 Highest oscillator frequency is 470 MHz.

10.11 Necessary Bandwidth and Emission Bandwidth

REGULATIONS	: 47 CFR 2.202 (g) & Federal Register/ Vol.68, No236
	TRC 43

Calculation Results

State : 16K0F3E (Authorized Bandwidth 20 kHz)

Item	Mark		
Maximum Modulation	(M)	3	kHz
Maximum Deviation	(D)	5	kHz
Constant Factor	(K)	1	
Necessary Bandwidth	(Bn)	16	kHz

$$B_n = (2 \times M) + (2 \times D \times K)$$

State : 11K0F3E (Authorized Bandwidth 11.25 kHz)

Item	Mark		
Maximum Modulation	(M)	3	kHz
Maximum Deviation	(D)	2.5	kHz
Constant Factor	(K)	1	
Necessary Bandwidth	(Bn)	11	kHz

$$B_n = (2 \times M) + (2 \times D \times K)$$