



# TEST REPORT

**REGULATION :** **FCC Part 2, 22, 74, 90, 90.210**  
**RSS-119 Issue 9**

Applicant	Testing Laboratory
Kenwood Corporation 1-16-2, Hakusan, Midori-ku, Yokohama-shi Kanagawa, 226-8525 Japan Tel.: +81 45 939 6254 Fax.: +81 45 939 7097	Intertek Japan K. K. Kashima Laboratory 3-2, Sunayama, Kamisu-shi, Ibaraki-ken 314-0255 Japan Tel.: +81 479 40 1097 Fax.: +81 479 46 1788 URL: <a href="http://www.japan.intertek-etlsemko.com">http://www.japan.intertek-etlsemko.com</a>

<b>Equipment type</b>	VHF FM TRANSCEIVER
<b>Trademark</b>	KENWOOD
<b>Model(s)</b>	TK-7302H-1, TK-7302HV-1
<b>Serial No.</b>	None
<b>FCC ID</b>	K44407601
<b>IC CN and UPN</b>	282F-407601
<b>Test Result</b>	Complied
<b>Report Number</b>	JK09070002(R1)
<b>Report issue date</b>	August 17, 2009

This report is for the exclusive use of Intertek's Client and is provided pursuant to the agreement between Intertek and its Client. Intertek's responsibility and liability are limited to the terms and conditions of the agreement. Intertek assumes no liability to any party, other than to the Client in accordance with the agreement, for any loss, expense or damage occasioned by the use of this report. Only the Client is authorized to permit copying or distribution of this report and then only in its entirety. Any use of the Intertek name or one of its marks for the sale or advertisement of the tested material, product or service must first be approved in writing by Intertek. The observations and test results in this report are relevant only to the sample tested. This report by itself does not imply that the material, product, or service is or has ever been under an Intertek certification program.

The test report JK09070002 was superseded by this test report.

Approved by

*K. Gokita*

Kazuo Gokita

[Site Manager]

Tested by

*K. Wagatsuma*

Koichi Wagatsuma

**In Accordance with FCC Rules and Regulations, Volume II, Part 2 and 90****Sub-part 2.1033**

<b>(c)(1) Applicant and Manufacture Information</b>	
APPLICANT	
Company	: Kenwood Corporation
Address	: 1-16-2, Hakusan, Midori-ku, Yokohama-shi, Kanagawa, 226-8525 Japan
Contact Person	: Tamaki Shimamura Manager, Communications Equipment Division
MANUFACTURER	
Company	: Kenwood Corporation
Address	: 1-16-2, Hakusan, Midori-ku, Yokohama-shi, Kanagawa, 226-8525 Japan
<b>(c)(2) FCC ID</b>	
FCC ID	: K44407601
Model number	: TK-7302H-1, TK-7302HV-1
Serial number	: None
<b>(c)(3) Instruction Manual(S)</b>	
Instruction manual(s)	: Please refer to attached Exhibits F
<b>(c)(4) Type of Emission</b>	
Emission Designation	: 16K0F3E(Wide) /11K0F3E(Narrow)
<b>(c)(5) Frequency range</b>	
Frequency Range	: 150 to 174 MHz / 138 to 144, 148 to 174 MHz
<b>(c)(6) Power Rating</b>	
Output Power	: 5 to 50 W
Type	: Continuously Variable
<b>(c)(7) Maximum Power Rating</b>	
Output Power	: 50 W
<b>Other Information</b>	
Number of Channel	: 16
Maximum Deviation	: 5 kHz / 2.5kHz
Frequency Stability	: 2.5 ppm
Antenna Impedance	: 50 $\Omega$ Norminal
<b>Note</b>	

## TABLE OF CONTENTS

---

	Page
SECTION 1. GENERAL INFORMATION	4
SECTION 2. SUMMARY OF TEST RESULT	5
SECTION 3. TEST AND MEASUREMENT DATA	6
SECTION 4. INFORMATION ABOUT EUT AND SUPPORT EQUIPMENT(S)	7
SECTION 5. SUPPORT EQUIPMENT	8
SECTION 6. USED CABLE(S)	9
SECTION 7. TEST CONFIGURATION	10
SECTION 8. OPERATING CONDITION	11
SECTION 9. MEASUREMENT UNCERTAINTY	12
SECTION 10. TEST DATA	
10.1 Carrier Output Power (Conducted)	13
10.2 Unwanted Emissions (Transmitter Conducted)	15
10.3 Field Strength of Spurious Radiation	18
10.4 Emission Masks (Occupied Bandwidth)	22
10.5 Transient Frequency Behavior	28
10.6 Audio Frequency Response / Audio Low Pass Filter (Voice Input)	32
10.7 Modulation Limiting	35
10.8 Frequency Stability (Temperature Variation)	41
10.9 Frequency Stability (Voltage Variation)	44
10.10 Receiver Spurious Emissions(Radiated)	46
10.11 Necessary Bandwidth and Emission Bandwidth	50
APPENDIX           PHOTOGRAPHS	

---

**SECTION 1. GENERAL INFORMATION****TEST PERFORMED**

Location	Kashima No.1 Test Site
EUT Received	June 29, 2009
Date of Test	July 02, 2009 to August 03, 2009
Standard Applied	FCC Part 2, 22, 74, 90, 90.210 RSS-119 Issue 9
Measurement Method	ANSI/TIA-603-C-2004 / RSS-119 Issue 9(2007), RSS-Gen Issue 2(2007)
Deviation from Standard(s)	Not applicable

**QUALIFICATIONS OF TESTING LABORATORY**

ACCREDITATION	SCOPE	LAB. CODE	Remarks
NVLAP	EMC Testing	100290-0	
VLAC	EMC Testing	VLAC-008-1	JAPAN
BSMI	EMC Testing	SL2-IN-E-6008	TAIWAN
<b>FILING</b>			
VCCI	EMC Testing	R-788, C-278, C-279, T-351, T-352 R-274, C-280, C-281, T-353, T-359 R-272, C-276, C-277, T-360, T-361 R-576, C-590, T-362	JAPAN
FCC	EMC Testing	Designation Number:JP0008	USA
IC	EMC Testing	IC-2042K-1, IC-2042K-3	CANADA
SAUDI ARABIA	EMC Testing	N/A	

**ABBREVIATIONS**

EUT	Equipment Under Test	DoC	Declaration of Conformity
AMN	Artificial Mains Network	ISN	Impedance Stabilization Network
LISN	Line Impedance Stabilization Network	Q-P	Quasi-peak
AMP	Amplifier	AVG	Average
ATT	Attenuator	PK	Peak
ANT	Antenna	Cal	Calibration
BBA	Broadband Antenna	N/A	Not applicable or Not available
DIP	Dipole Antenna	LCD	Liquid-Crystal Display
AE	Associated Equipment	4LEVEL FSK	4LEVEL Frequency Shift Key
GMSK	Gaussian Maximum Shift Key	CW ID	Continuously Repeating bit stream
FM	Frequency Modulation	C4FM	Constant envelope 4 Level FM
PTT	Push to Talk		

**SECTION 2. SUMMARY OF TEST RESULT**

FCC Part2	Part22	Part74	Part90	IC RSS-119	TEST ITEM	RESULTS
2.1046 (a)	-	74.461	-	5.4	Carrier Output Power (Conducted)	PASS
2.1051	-	-	90.210	5.8	Unwanted Emissions (Transmitter Conducted)	PASS
2.1053 (a)	-	-	90.210	5.8	Field Strength of Spurious Radiation	PASS
2.1049 (c) (1)	22.359, 357 (a)	74.462	90.210	5.8	Emission Masks (Occupied Bandwidth)	PASS
-	-	-	90.214	5.9	Transient Frequency Behavior	PASS
2.1047 (a)	-	-	90.242 (b) (8)	-	Audio Low Pass Filter (Voice Input)	PASS
2.1047 (a)	-	-	-	-	Audio Frequency Response	PASS
2.1047 (b)	-	-	-	-	Modulation Limiting	PASS
2.1055 (a) (1)	22.355	74.464	90.213 (a)	5.3	Frequency Stability (Temperature Variation)	PASS
2.1055 (d) (1)	22.355	74.464	90.213 (a)	5.3	Frequency Stability (Voltage Variation)	PASS
-	-	-	-	5.11	Receiver Spurious Emissions	PASS

**Limitation on Results**

The test result of this report is effective equipment under test itself and under the test configuration described on the report. This test report does not assure that whether the test result taken in other testing laboratory is compatible or reproducible to the test result on this report or not.

**Note:**

As for the FCC Part 15 Subpart B-Unintentional Radiators, the EUT has been measured and declared as Verification by Kenwood Corporation.

**SECTION 3. TEST AND MEASUREMENT DATA**

All test and measurements indicated in this document were performed in accordance with the Code of Federal Regulations Title 47 Part 2, Sub-part J and Industry Canada as the following individual parts:

FCC Rule	Test Item	Tested
Part 21	Domestic Public Fixed radio Services	N.A.
<b>Part 22</b>	<b>Non Cellular</b>	<b>YES</b>
Part 22	Public Mobile Services	N.A.
Part 22	Subpart H - Cellular Radiotelephone Service	N.A.
Part 22	Alternative technologies and auxiliary service	N.A.
Part 23	International Fixed Public Radiocommunication service	N.A.
Part 24	Personal Communications Services	N.A.
<b>Part 74</b>	<b>Experimental Radio Auxiliary , Special Broadcast and Other Program Distributional Services</b>	<b>YES</b>
Part 80	Stations in the Maritime Services	N.A.
Part 80	Subpart E - general Technical Standards	N.A.
Part 80	Subpart F - Equipment Authorization for Compulsory Ships	N.A.
Part 80	Subpart K - Private Coast Stations and Marine Utility Stations	N.A.
Part 80	Subpart S - Compulsory radiotelephone Installations for Small Passenger Boats	N.A.
Part 80	Subpart T - Radiotelephone Installation Required for Vessels on the Great Lakes	N.A.
Part 80	Subpart U - Radiotelephone Installations Required by the Bridge-to-Bridge Act	N.A.
Part 80	Subpart V - Emergency Position Indicating Radiobeacons (EPIRB'S)	N.A.
Part 80	Subpart W - Global Maritime Distress and Safety System (GMDSS)	N.A.
Part 80	Subpart X - Voluntary Radio Installations	N.A.
Part 87	Aviation Services	N.A.
<b>Part 90</b>	<b>Private Land Mobile radio Services</b>	<b>YES</b>
Part 94	Private Operational - Fixed Microwave Service	N.A.
Part 95	Subpart A - General Mobile radio Service	N.A.
Part 95	Subpart C - Radio Control (R/C) radio Service	N.A.
Part 95	Subpart D - Citizens Band (CB) Radio Service	N.A.
Part 95	Subpart E -Family radio Service	N.A.
Part 95	Subpart F -Interactive Video and Data Service (IVDS)	N.A.
Part 97	Amateur Radio Service	N.A.
Part 101	Fixed Microwave Service	N.A.

IC Rule	Test Item	Tested
<b>RSS-119</b>	<b>Land Mobile and Fixed Radio Transmitters and Receivers</b>	<b>YES</b>
<b>RSS-Gen</b>	<b>General Requirements and Information for the Certification of Radiocommunication Equipment</b>	<b>YES</b>

**SECTION 4. INFORMATION ABOUT EUT AND SUPPORT EQUIPMENT(S)****4.1 List of System Configuration**

Symbol	Item	Model No.	Serial No.	Manufacture	Remarks
A1	VHF FM TRANSCEIVER	TK-7302H-1, TK-7302HV-1	None	Kenwood	EUT
<b>Power Ratings of EUT :</b>		DC 13.6 V +/- 15 %	15.0 A Maximum		
<b>Power Supply :</b>		DC 13.6 V +/- 15 %			
<b>Condition of Equipment</b>		Proto type			
<b>Type</b>		Mobile type			
<b>Suppression Devices</b>		No Modifications by the laboratory were made to the device			

**4.2 Port(s)/Connector(s)**

Port Name	Connector Type	Connector Pin	Remarks
ACC	D-sub	15 pin	
Speaker	3.5φ	2 pin	
Antenna	M	2 pin	
Microphone	Kenwood original	12 pin	

**4.3 Highest Frequency Oscillator(s)/Crystal(s)**

Base Clock	Operating Frequenc	Board Name	Remarks
212.85 MHz	212.85 MHz	TXRX Unit	

**SECTION 5. SUPPORT EQUIPMENT**

The EUT was supported by the following equipment during the test.

Symbol	Item	Model No.	Serial No.	Manufacture	FCC ID
B	DC Power Supply	PS-3020	None	Daiwa	N/A
F	DC Power Supply	10A	None	Micky	N/A
C	External Speaker	KES-5	None	Kenwood	N/A
D	Keypad Microphone	KMC-28	None	Kenwood	N/A
E	Dummy Load	CT-150NP	1138693	TME	N/A
Supplied Power:					
B, F	AC	100V,60Hz			



**SECTION 6. USED CABLE(S)**

The following cable(s) was used for the test.

No.	Name	Length (m)	Shield	Connector
1	Speaker cable	2.90	No	Plastic
2	Antenna cable	0.90	Yes	Metal
3	Mic. cable	0.55	No	Plastic
4	DC cable for EUT	0.25	Yes	Plastic
5	KCT-60(Connection cable)	0.30	No	Plastic
6	KCT-18(Ignition sense cable)	3.15	Yes	Plastic
7	DC cable for EUT	3.00	No	Plastic
8	Power cable for DC Power Supply	1.70	No	-

## SECTION 7. TEST CONFIGURATION

### Details of Configuration and Connection

Example: Case of Section 10.3 Test

\* : EUT

□ : Joint Connector

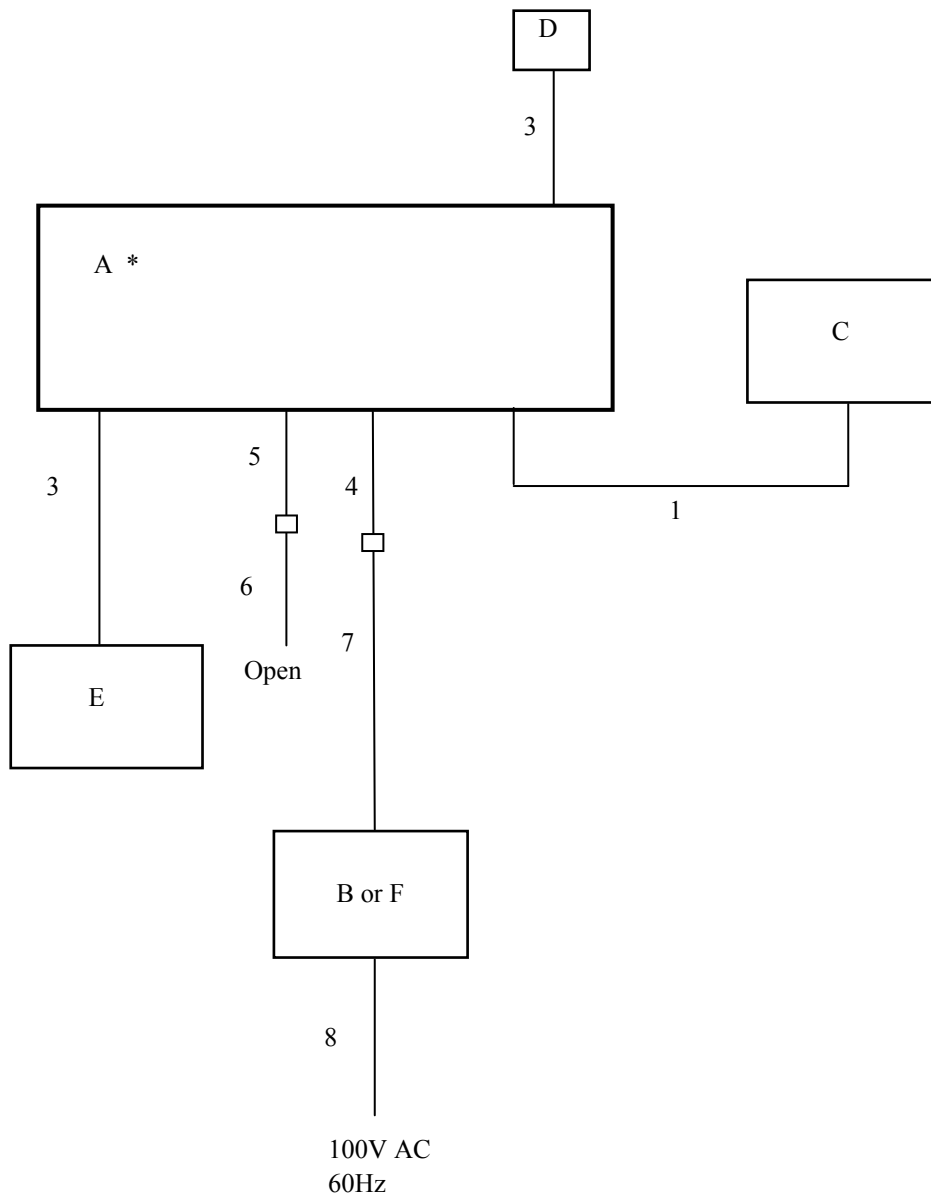

## SECTION 8. OPERATING CONDITION

The EUT was operated under the following condition during the test.

### 8.1 Operating Condition

The test was carried out under Transmit mode.

(CFR:150.05MHz, 162.05MHz, 173.95MHz, RSS:138.05MHz, 156.05MHz, 173.95MHz)

The test was carried out under Recive mode.

(RSS:138.05MHz, 156.05MHz, 173.95MHz)

EUT was examined in the operating conditions that had maximum emissions.

### 8.2 Operating Flow [Transmit mode]

Following operations were performed continuously.

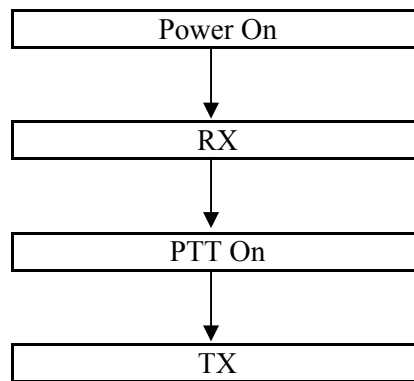

### 8.3 Operating Flow [Recive mode]

Following operations were performed continuously.

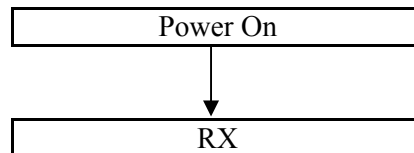

**SECTION 9. MEASUREMENT UNCERTAINTY**

Carrier Output Power (Conducted)	$U_{lab}$	$U_{tia-603-c}$
	+/- 0.29dB ( $k = 2$ )	+/- 0.59 dB
Unwanted Emissions (Transmitter Conducted)		
	+/- 2.19 dB ( $k = 2$ )	+/- 1.1 dB
Field Strength of Spurious Radiation		
	+/- 4.3dB ( $k = 2$ )	+/- 3.3 dB
Emission Masks (Occupied Bandwidth)		
	+/- 0.5dB ( $k = 2$ )	+/- 2.1 dB
Transient Frequency Behavior		
	+/- 1.10% ( $k = 2$ )	+/- 21.6 %
Audio Low Pass Filter (Voice Input)		
	+/- 0.1dB ( $k = 2$ )	+/- 1.2 dB
Audio Frequency Response		
	+/- 0.1dB ( $k = 2$ )	+/- 1.2 dB
Modulation Limiting		
	+/- 1% ( $k = 2$ )	+/- 1 %
Frequency Stability (Temperature Variation)		
	+/- 14.9Hz ( $k=2$ )	+/-34.2 Hz
Frequency Stability (Voltage Variation)		
	+/- 14.9Hz ( $k=2$ )	+/-34.2 Hz
Receiver Spurious Emissions	$U_{lab}$	$U_{cispr}$
30-1000MHz	+/- 4.1dB ( $k = 2$ )	+/- 5.2 dB
1-40GHz	+/- 4.3dB ( $k = 2$ )	

**SECTION 10. TEST DATA**

**10.1 Carrier Output Power (Conducted)**

REGULATIONS	: 47 CFR 2.1046 (a) / RSS-119 Section 5.4
TEST METHOD/GUIDE	: ANSI/TIA-603-C Section 2.2.1.2 / RSS-119 Section 4.1

**Test Procedure**

- 1 The EUT and test equipment were set up as shown on the following page.
- 2 The EUT was conducted to a resistive coaxial attenuator of normal load impedance.  
 $RF\ Power\ (dBm) = Power\ Meter\ reading\ (dBm) + Attenuator\ Loss\ (dB) + Cable\ Loss\ (dB)$   
 $RF\ Power\ (W) = 10^{(RF\ Power\ (dBm)/10)}/1000$
- 3 Modulate the transmitter with a 2.5 kHz sine wave at an input Level of 16 dB greater than that necessary to produce 50 % of rated system deviation.(Only as for the test of RSS)

**Measuring Equipments**

No.	Equipment	Manufacture	Model No.	Serial No.	Cal Date	Cal Exp.
1	Power Meter	Hewlett Packard	E4418B	GB38410265	May 26, 09	May. 31, 10
2	Power Sensor	Hewlett Packard	8482A	US37292237	May 26, 09	May. 31, 10
3	Attenuator (20dB)	Aeroflex/Wenshel	66-20-34	BY4537	Mar. 30, 09	Mar. 31, 10
4	Attenuator (30dB)	Weinschel	WA-29-30-34	8923	May. 15, 09	May. 31, 10
5	Audio Generator	Anritsu	MG443B	M70150	Apr. 01, 09	Apr. 30, 10
6	Digital Multi Meter	Agilent	34401A	MY45028851	May. 27, 09	May. 31, 10
7	DC Power Supply	Daiwa	PS-3020	None	None	None

**Measuring Cables**

No.	Cable	Manufacturer	Model No.	Serial No.	Cal Date	Cal Exp.
W1	Coaxial Cable	Suhner	SUCOFLEX104	KSR00091	May. 15, 09	May. 31, 10
W6	Balance Cable	Nicoon	3D-2V	KSR00092	Oct. 09, 08	Oct. 31, 09

**Measuring Equipment Configuration**

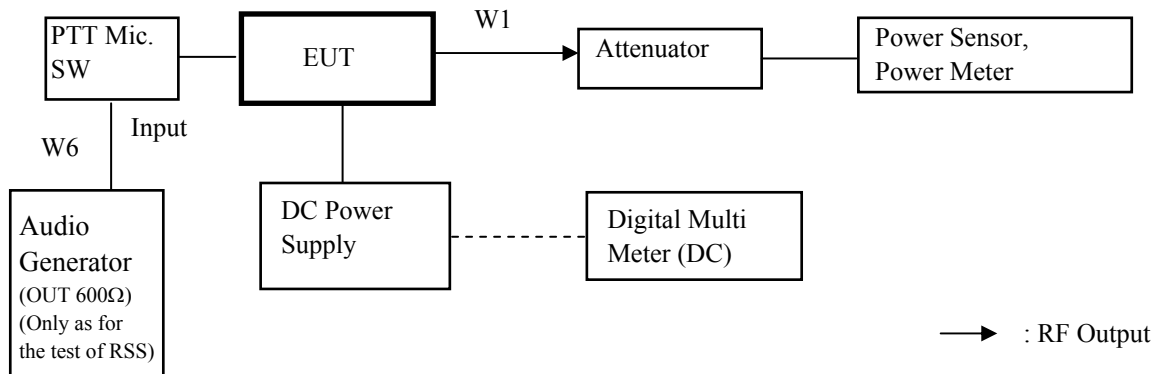

**Test Results**

Test date	Jul 2, 2009
Location	Kashima No.1 Test Site
temperature	23 to 27 [degree C]
Humidity Variation	63 to 67 [%]
Atmospheric Pressure	99.6 to 99.9 [kPa]
Test Engineer	Koichi Wagatsuma

No.	Frequency (MHz)	Band	Setting	RF Power (W)
1	138.05	Low (RSS)	High Power	50
2	156.05	Middle (RSS)	High Power	50
3	150.05	Low (CFR)	High Power	50
4	162.05	Middle (CFR)	High Power	50
5	173.95	High (CFR/RSS)	High Power	50
6	138.05	Low (RSS)	Low Power	5
7	156.05	Middle (RSS)	Low Power	5
8	150.05	Low (CFR)	Low Power	5
9	162.05	Middle (CFR)	Low Power	5
10	173.95	High (CFR/RSS)	Low Power	5

## 10.2 Unwanted Emissions (Transmitter Conducted)

REGULATIONS	: 47 CFR 2.1051, 90.210 / RSS-119 Section 5.8
TEST METHOD/GUIDE	: ANSI/TIA-603-C Section 2.2.13.2 / RSS-119 Section 4.2, RSS-Gen Section 4.9

### Test Procedure

- 1 The EUT and test equipment were set up as shown on the following page.
- 2 Modulate the transmitter with a 2.5 kHz sine wave at an input Level of 16 dB greater than that necessary to produce 50 % of rated system deviation.
- 3 Adjust the spectrum analyzer for the following setting:
  - a) RBW : 10 kHz (< 1 GHz), 1 MHz (> 1 GHz).
  - b) VBW : 30 kHz (< 1 GHz), 3 MHz (> 1 GHz).
  - c) Sweep Speed : 50 msec.
  - d) Detector mode : Average power (FM Modulation) , Positive peak with peak hold (C4FM Modulation)
- 4 The emissions were measured for the worst case as follows:
  - a) : within a band of frequencies defined by the carrier frequency plus and minus one channel.
  - b) : from the lowest frequency generated in the EUT and to at least the 10th harmonic of the carrier frequency, or 40 GHz, whichever is lower.

### Measuring Equipments

No.	Equipment	Manufacture	Model No.	Serial No.	Cal Date	Cal Exp.
1	Audio Generator	Anritsu	MG443B	M70150	Apr. 01, 09	Apr. 30, 10
2	Attenuator (10dB)	Aeroflex/Wenschel	66-10-34	BY2887	Mar. 30, 09	Mar. 31, 10
3	Attenuator (30dB)	Weinschel	WA-29-30-34	8923	May. 15, 09	May. 31, 10
4	Modulation Analyzer	Hewlett Packard	8901B	2806A01669	Feb. 23, 09	Feb. 28, 10
5	Signal Generator	Rohde&Schwarz	SMT06	100684	Dec. 12, 08	Dec. 31, 09
6	Spectrum Analyzer	Agilent	E4407B	MY45102460	Feb 09, 09	Feb. 28, 10
7	Highpass Filter	Anritsu	MP526B	6200220636	Jan. 14, 09	Jan. 31, 10
8	Digital Multi Meter	Agilent	34401A	MY45028851	May. 27, 09	May. 31, 10
9	DC Power Supply	Daiwa	PS-3020	None	None	None

### Measuring Cables

No.	Cable	Manufacturer	Model No.	Serial No.	Cal Date	Cal Exp.
W1	Coaxial Cable	Suhner	SUCOFLEX104	KSR00091	May. 15, 09	May. 31, 10
W2	Coaxial Cable	Suhner	SUCOFLEX104	KSR00042	Mar. 12, 09	Mar. 31, 10
W4	Coaxial Cable	Pacific custom	RG-58 C/U	AM90C03	Jan. 14, 09	Jan. 31, 10
W6	Balance Cable	Nicoon	3D-2V	KSR00092	Oct. 09, 08	Oct. 31, 09

**Measuring Equipment Configuration**

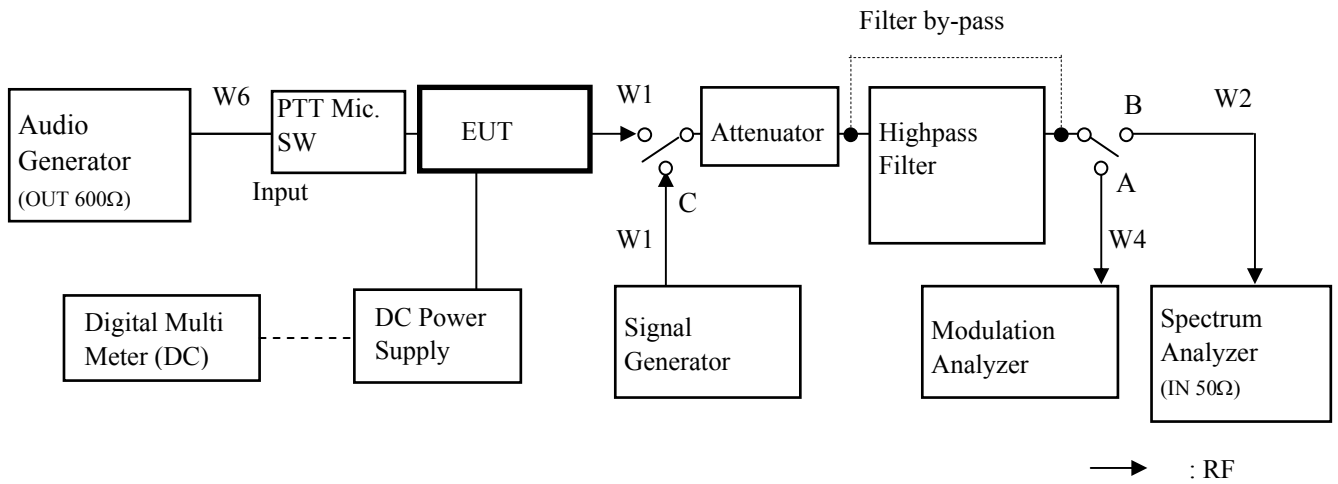



**Test Results**

Test date	Jul 8, 2009
Location	Kashima No.1 Test Site
temperature	25.2 to 25.6 [degree C]
Humidity Variation	49 to 66 [%]
Atmospheric Pressure	100.2 to 100.5 [kPa]
Test Engineer	Koichi Wagatsuma

Test carried out for all the frequency band of section 10.1

Measured for the worst case

State : High Power / Authorized Bandwidth 11.25 kHz

No.	Band	Frequency (MHz)	Correct Level (dBm)	Emission Level (dBc)	Limit (dBc)	Margin (dB)
1	Low (RSS)	276.10	-37.98	-84.97	-67.0	18.0
2	Middle (RSS)	468.15	-45.99	-92.98	-67.0	26.0
3	Low (CFR)	300.10	-47.39	-94.38	-67.0	27.4
4	Middle (CFR)	324.10	-50.75	-97.74	-67.0	30.8
5	High (CFR/RSS)	347.90	-42.05	-89.04	-67.0	22.1

There is the margin of 20dB over except for the above points.

State : Low Power / Authorized Bandwidth 11.25 kHz

No.	Band	Frequency (MHz)	Correct Level (dBm)	Emission Level (dBc)	Limit (dBc)	Margin (dB)
1	Low (RSS)	276.10	-46.58	-83.57	-57.0	26.6
2	Middle (RSS)	312.10	-39.03	-76.02	-57.0	19.0
3	Low (CFR)	300.10	-38.59	-75.58	-57.0	18.6
4	Middle (CFR)	324.10	-39.83	-76.82	-57.0	19.8
5	High (CFR/RSS)	347.90	-40.65	-77.64	-57.0	20.7

There is the margin of 20dB over except for the above points.

Mask D Limit (dBc) =  $-(50+10\log(P))$

Correct Level (dBm) = Substitute SG Level (dBm)

Emission Level (dBc) = Correct Level (dBm) -  $10\log(P*1000)$

P = Carrier Level (W)

" - " = Measurement Limit

### 10.3 Field Strength of Spurious Radiation

REGULATIONS	: 47 CFR 2.1053 (a), 90.210 / RSS-119 Section 5.8
TEST METHOD/GUIDE	: ANSI/TIA-603-C Section 2.2.12.2 / RSS-119 Section 4.2, RSS-Gen Section 4.9

#### Test Procedure

- 1 The EUT and test equipment were set up as shown on the following page.
- 2 Adjust the spectrum analyzer for the following setting:
  - a) RBW : 10 kHz (< 1 GHz), 1 MHz (> 1 GHz).
  - b) VBW : 300 kHz (< 1 GHz), 3 MHz (> 1 GHz).
  - c) Sweep Speed : 50ms.
  - d) Detector mode : Positive Peak
- 3 The transmitter was placed on a wooden turntable, and it was transmitting into non-radiating load which was also placed on the turntable.
- 4 The measurement antenna was placed at a distance of 3 meters from the EUT. During the tests, the antenna height and polarization as well as EUT azimuth were varied in order to identify the maximum level of emissions from the EUT. The test was performed by placing the EUT on 3-orthogonal axis.
- 5 The frequency range up to tenth harmonic of the fundamental frequency was investigated.
- 6 Remove the EUT and replace it with substitution antenna. A signal generator was connected to the substitution antenna by a non-radiating cable. The absolute levels of the spurious emissions were measured by the substitution.
- 7 Spurious emissions in dB = 10 Log (TX power in Watts/0.001) – the absolute level

#### Measuring Equipments

No.	Equipment	Manufacture	Model No.	Serial No.	Cal Date	Cal Exp.
1	Dipole Antenna(TX)	Schwarzbeck	UHA9105	AM0082002	May 18, 09	May. 31, 10
2	D.R.G Antenna(RX)	Schwarzbeck	3117	KSR00038	Aug 06, 08	Aug. 31, 09
3	Tri-log Antenna(RX)	Schwarzbeck	VULB9168WP	287	Nov 18, 08	Nov. 30, 09
4	Pre-Amplifier	Hewlett Packard	83051A	3332A00329	Oct. 31, 08	Oct. 31, 09
5	Attenuator(6dB)	Anritsu	MP721B	M57593 (1Site)	Nov. 12, 08	Nov. 30, 09
6	Attenuator(3dB)	Narda	4768-3	79	Oct. 31, 08	Oct. 31, 09
7	Attenuator(10dB)	HUBER+SUHNER	6810.17B	KSR0044	Jan. 14, 09	Jan. 31, 10
8	Step Attenuator	Hewlett Packard	8494B	2726A14513	Nov. 12, 08	Nov. 30, 09
9	Spectrum Analyzer	Agilent	E4407B	MY45102460	Feb. 09, 09	Feb. 28, 10
10	Signal Generator	Rohde&Schwarz	SMT06	100684	Dec. 12, 08	Dec. 31, 09
11	Dummy Load	TME	CT-150NP	1138693	Sep. 09, 08	Sep. 30, 09
12	Digital Multi Meter	Agilent	34401A	MY45028851	May. 27, 09	May. 31, 10
13	DC Power Supply	Daiwa	PS-3020	None	None	None

**Measuring Cables**

No.	Cable	Manufacturer	Model No.	Serial No.	Cal Date	Cal Exp.
W1	Coaxial Cable	Suhner	SUCOFLEX104	KSR00091	May. 15, 09	May. 31, 10
W2	Coaxial Cable	Suhner	SUCOFLEX104	KSR00046	Jan. 14, 09	Jan. 31, 10
W8	Coaxial Cable	Radiall	R286401332	KSR00048	Jan. 14, 09	Jan. 31, 10
R1	Coaxial Cable	Intertek Japan	5D-2W	None	Nov. 12, 08	Nov. 30, 09
R2	Coaxial Cable	Intertek Japan	10D-2W	None	Nov. 12, 08	Nov. 30, 09
R3	Coaxial Cable	Intertek Japan	5D-2W	None	Nov. 12, 08	Nov. 30, 09
R14	Coaxial Cable	Suhner	SUCOFLEX102	712/2	Oct. 31, 08	Oct. 31, 09
R15	Coaxial Cable	Insulated Wire	KSP-1501-1969- KPS	03292003	Oct. 31, 08	Oct. 31, 09
W12	Coaxial Cable	Intertek Japan	5D-2W	KSR00098	Jan. 14, 09	Jan. 31, 10
W13	Coaxial Cable	Suhner	SUCOFLEX100	KSR00207	Jun. 12, 09	Jun. 30, 10

**Measuring Equipment Configuration**

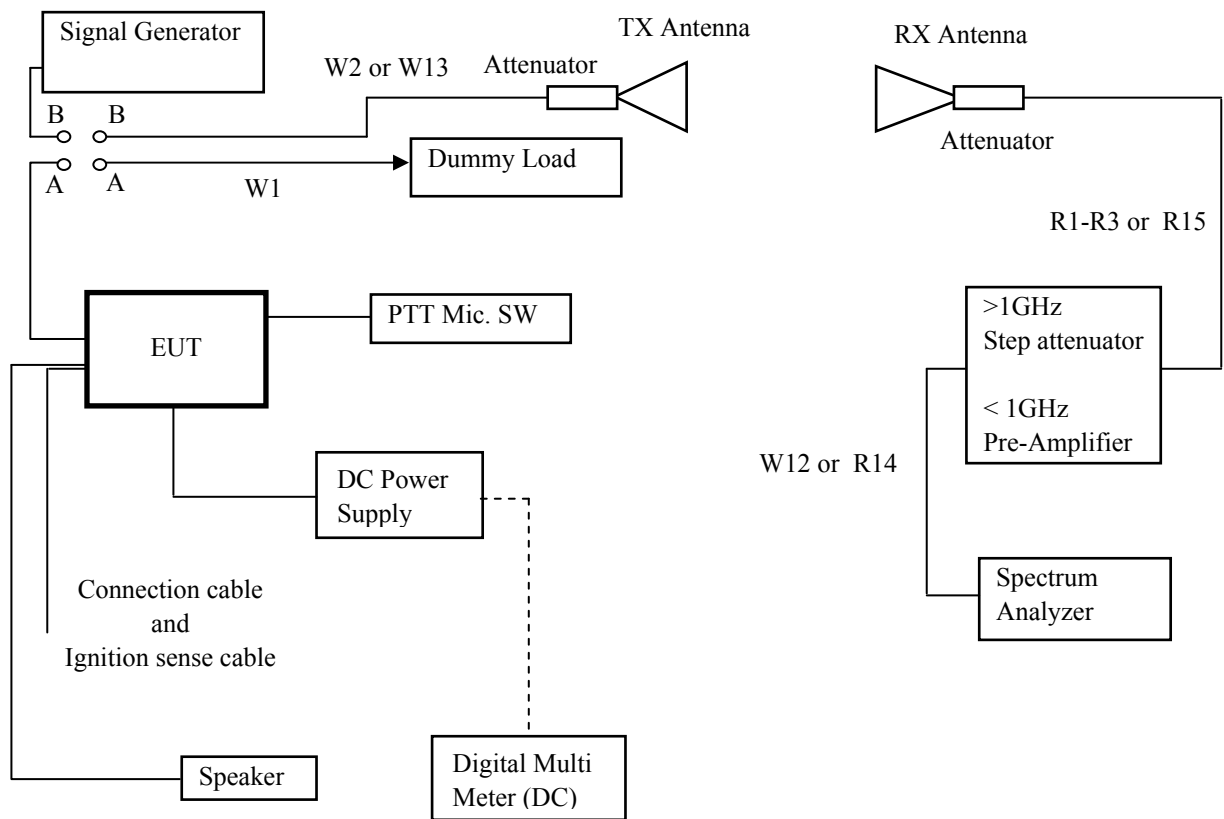

→ : RF Output

**Test Results**

Test date	July 14, 2009	to	Jul 16, 2009
Location	Kashima No.1 Test Site		
temperature	22.3 to 26.4		[degree C]
Humidity Variation	50 to 72		[%]
Atmospheric Pressure	99.8 to 100.9		[kPa]
Test Engineer	Koichi Wagatsuma		

Test carried out for all the frequency band of section 10.1

Measured for the worst case

State : High Power / Authorized Bandwidth 11.25 kHz / 173.95 MHz (CFR/RSS)

No	Frequency (MHz)	Pol	Reading Level (dBm)	SG Out Level (dBm)	Loss (dB)	Antenna Gain (dBi)	Correct Level (dBm)	Emission Level (dBc)	Limit Level (dBc)	Margin (dB)
1	347.90	Hor.	-68.08	-28.20	11.28	2.15	-37.3	-84.3	-67.0	17.3
		Ver.	-67.72	-24.80	11.28	2.15	-33.9	-80.9	-67.0	13.9
2	521.85	Hor.	-75.93	-28.80	11.67	2.15	-38.3	-85.3	-67.0	18.3
		Ver.	-64.67	-15.80	11.67	2.15	-25.3	-72.3	-67.0	5.3
3	695.80	Hor.	-83.65	-35.00	11.92	2.15	-44.8	-91.8	-67.0	24.8
		Ver.	-81.64	-29.40	11.92	2.15	-39.2	-86.2	-67.0	19.2
4	869.75	Hor.	-93.89	-42.00	12.16	2.15	-52.0	-99.0	-67.0	32.0
		Ver.	-89.72	-36.40	12.16	2.15	-46.4	-93.4	-67.0	26.4
5	1043.70	Hor.	-59.39	-43.80	12.32	6.33	-49.8	-96.8	-67.0	29.8
		Ver.	-59.72	-45.00	12.32	6.33	-51.0	-98.0	-67.0	31.0
6	1217.65	Hor.	-55.09	-36.70	12.63	6.81	-42.5	-89.5	-67.0	22.5
		Ver.	-56.63	-41.60	12.63	6.81	-47.4	-94.4	-67.0	27.4
7	1391.60	Hor.	-55.64	-39.10	12.93	7.88	-44.1	-91.1	-67.0	24.1
		Ver.	-59.07	-44.60	12.93	7.88	-49.6	-96.6	-67.0	29.6
8	1565.55	Hor.	-65.45	-50.40	13.26	8.83	-54.8	-101.8	-67.0	34.8
		Ver.	-63.57	-54.00	13.26	8.83	-58.4	-105.4	-67.0	38.4
9	1739.50	Hor.	-61.68	-48.60	13.63	8.13	-54.1	-101.1	-67.0	34.1
		Ver.	-61.37	-46.10	13.63	8.13	-51.6	-98.6	-67.0	31.6

There is the margin of 20dB over except for the above points.

Mask D Limit (dBc) =  $-(50+10\log(P))$

Correct Level (dBm) = Substitute SG Level (dBm) + ANT Gain (dB) - Loss (Cable, Attenuator) (dB)

Emission Level (dBc) = Correct Level (dBm) -  $10\log(P*1000)$

P = Carrier Level (W)

" - " = Measurement Limit

State : Low Power / Authorized Bandwidth 11.25 kHz / 173.95 MHz (CFR/RSS)

No	Frequency (MHz)	Pol	Reading Level (dBm)	SG Out Level (dBm)	Loss (dB)	Antenna Gain (dBi)	Correct Level (dBm)	Emission Level (dBc)	Limit Level (dBc)	Margin (dB)
1	347.90	Hor.	-72.95	-32.20	11.28	2.15	-41.3	-78.3	-57.0	21.3
		Ver.	-65.45	-22.80	11.28	2.15	-31.9	-68.9	-57.0	11.9
2	521.85	Hor.	-71.79	-24.60	11.67	2.15	-34.1	-71.1	-57.0	14.1
		Ver.	-66.21	-17.20	11.67	2.15	-26.7	-63.7	-57.0	6.7
3	695.80	Hor.	-80.18	-31.40	11.92	2.15	-41.2	-78.2	-57.0	21.2
		Ver.	-77.46	-25.00	11.92	2.15	-34.8	-71.8	-57.0	14.8
4	869.75	Hor.	-94.51	-43.80	12.16	2.15	-53.8	-90.8	-57.0	33.8
		Ver.	-92.24	-39.40	12.16	2.15	-49.4	-86.4	-57.0	29.4
5	1043.70	Hor.	-	-	12.32	6.33	-	-	-57.0	-
		Ver.	-	-	12.32	6.33	-	-	-57.0	-
6	1217.65	Hor.	-63.46	-45.20	12.63	6.81	-51.0	-88.0	-57.0	31.0
		Ver.	-64.17	-54.10	12.63	6.81	-59.9	-96.9	-57.0	39.9
7	1391.60	Hor.	-62.25	-45.20	12.93	7.88	-50.2	-87.2	-57.0	30.2
		Ver.	-62.71	-50.10	12.93	7.88	-55.1	-92.1	-57.0	35.1
8	1565.55	Hor.	-62.51	-47.30	13.26	8.83	-51.7	-88.7	-57.0	31.7
		Ver.	-62.92	-53.20	13.26	8.83	-57.6	-94.6	-57.0	37.6
9	1739.50	Hor.	-	-	13.63	8.13	-	-	-57.0	-
		Ver.	-	-	13.63	8.13	-	-	-57.0	-

There is the margin of 20dB over except for the above points.

Mask D Limit (dBc) =  $-(50+10\log(P))$ 

Correct Level (dBm) = Substitute SG Level (dBm) + ANT Gain (dB) - Loss (Cable, Attenuator) (dB)

Emission Level (dBc) = Correct Level (dBm) -  $10\log(P*1000)$ 

P = Carrier Level (W)

" - " = Measurement Limit

**10.4 Emission Masks (Occupied Bandwidth)**

REGULATIONS : 47 CFR 2.1049 (c) (1), 22.359, 357 (a) (1) , 74.462 , 90.210 / RSS-119 Section 5.8

TEST METHOD/GUIDE : ANSI/TIA-603-C Section 2.2.11.2 / RSS-119 Section 4.2.1, 4.2.2

**Test Procedure**

- 1 The EUT and test equipment were set up as shown on the following page.
- 2 For EUT supporting audio modulation, the audio signal generator was adjusted to the frequency of maximum response and with output level set for +/- 2.5 kHz deviation (or 50 % modulation).
- 3 With level constant, the signal level was increased 16 dB.
- 5 Adjust the spectrum analyzer for the following setting:
  - a) RBW : 100Hz (Non modulation and Authorized Band 11.25 kHz),  
300Hz (Non modulation and Authorized Band 20 kHz).
  - b) VBW : 10times the RBW (Non modulation , Authorized Band 11.25 kHz and Authorized Band 20 kHz).
  - c) RBW and VBW : 30 kHz (Non Modulation of Authorized Band 6 kHz).
  - d) Sweep Speed : 8 sec.
  - e) Sampling Time : 10 times
- 6 The occupied Bandwidth was measured with the Spectrum Analyzer controls set as shown on the test results.

**Measuring Equipments**

No.	Equipment	Manufacture	Model No.	Serial No.	Cal Date	Cal Exp.
1	Audio Generator	Anritsu	MG443B	M70150	Apr. 01, 09	Apr. 30, 10
2	Attenuator (20dB)	Aeroflex/Wenshel	66-20-34	BY4537	Mar. 30, 09	Mar. 31, 10
3	Attenuator (30dB)	Weinschel	WA-29-30-34	8923	May. 15, 09	May. 31, 10
4	Combiner	Anritsu	Z-164A	M89549	Oct. 09, 08	Oct. 31, 09
5	Modulation Analyzer	Hewlett Packard	8901B	2806A01669	Feb. 23, 09	Feb. 28, 10
6	Spectrum Analyzer	Agilent	E4407B	MY45102460	Feb. 09, 09	Feb. 28, 10
7	Digital Multi Meter	Agilent	34401A	MY45028851	May. 27, 09	May. 31, 10
8	DC Power Supply	Daiwa	PS-3020	None	None	None

**Measuring Cables**

No.	Cable	Manufacture	Model No.	Serial No.	Cal Date	Cal Exp.
W1	Coaxial Cable	Suhner	SUCOFLEX104	KSR00091	May. 15, 09	May. 31, 10
W3	Coaxial Cable	Suhner	SUCOFLEX104	KSR00042	Mar. 12, 09	Mar. 31, 10
W5	Coaxial Cable	Pacific custom	RG-58 C/U	AM90C03	Jan. 14, 09	Jan. 31, 10
W6	Balance Cable	Nicoon	3D-2V	KSR00092	Oct. 09, 08	Oct. 31, 09

### Measuring Equipment Configuration

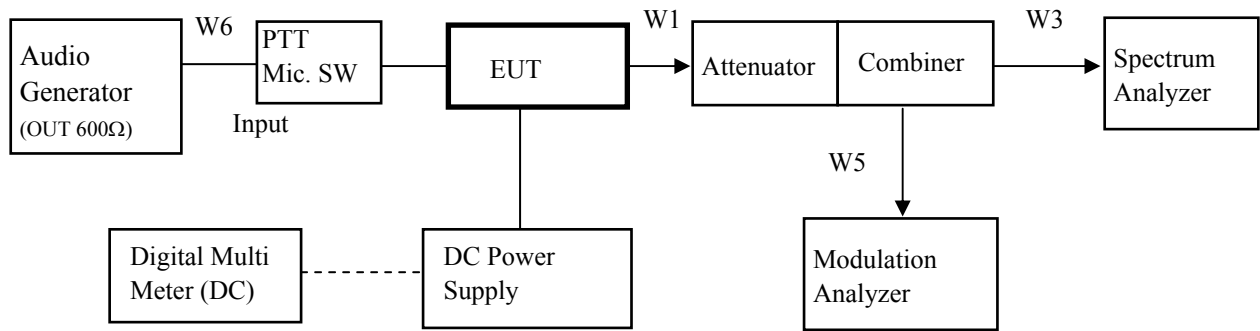

**Test Results**

Test date	Jul 7, 2009	
Location	Kashima No.1 Test Site	
temperature	24.6 to 25.5	[degree C]
Humidity Variation	58 to 59	[%]
Atmospheric Pressure	100.7 to 101.0	[kPa]
Test Engineer	Koichi Wagatsuma	

Test carried out for all the frequency band of section 10.1

Measured for the worst case

State : High Power / Authorized Bandwidth 20 kHz:FM / 150.05 MHz(CFR)

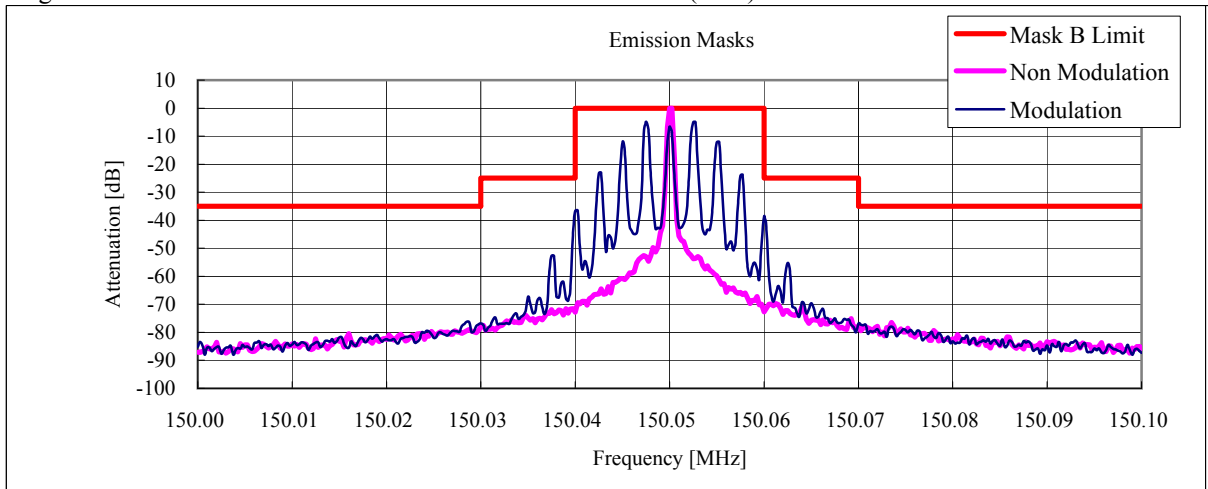

State : High Power / Authorized Bandwidth 11.25 kHz:FM / 150.05 MHz(CFR)

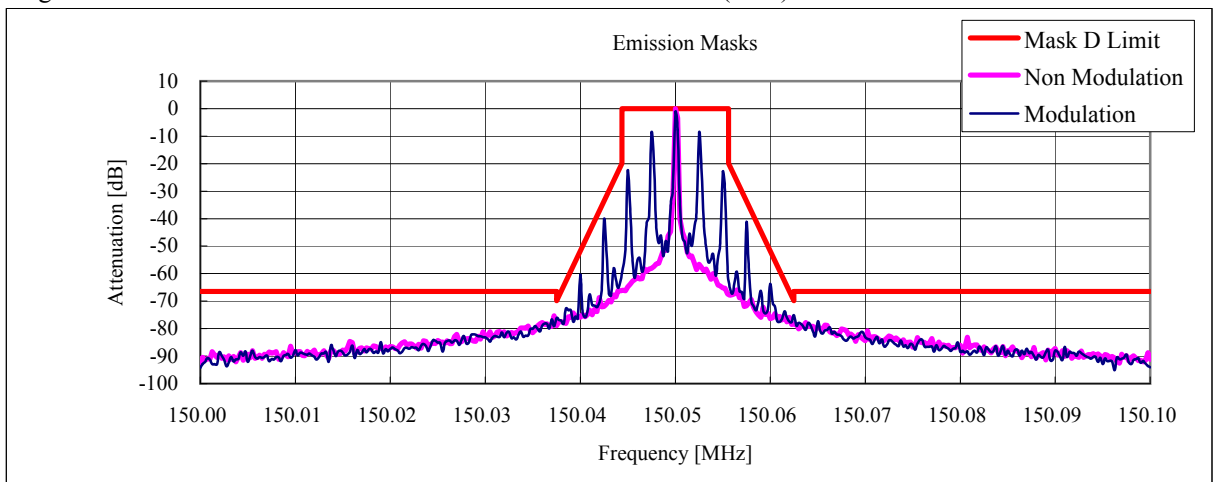



State : Low Power / Authorized Bandwidth 20 kHz:FM / 150.05 MHz(CFR)

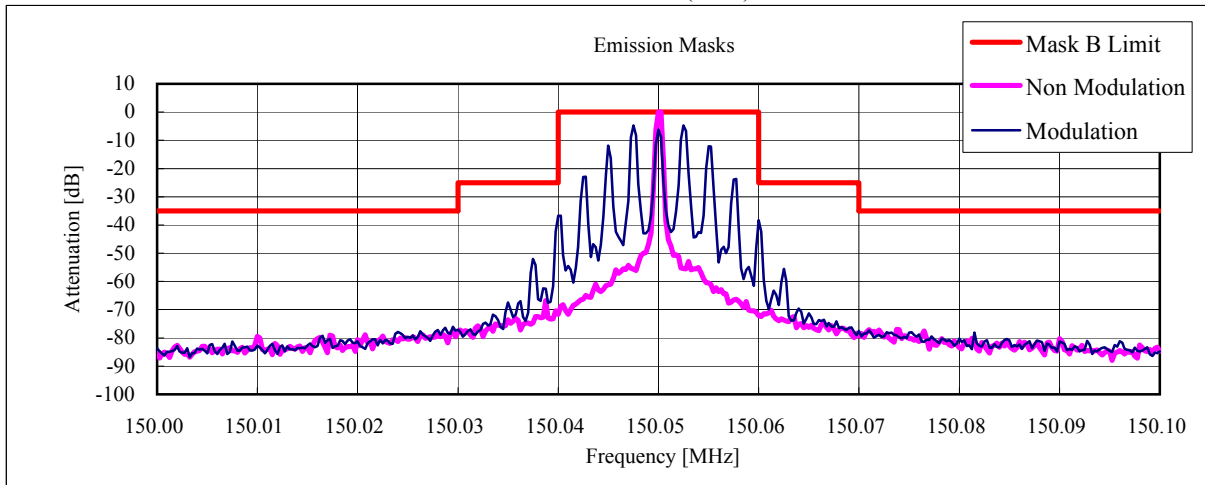

State : Low Power / Authorized Bandwidth 11.25 kHz:FM / 150.05 MHz(CFR)

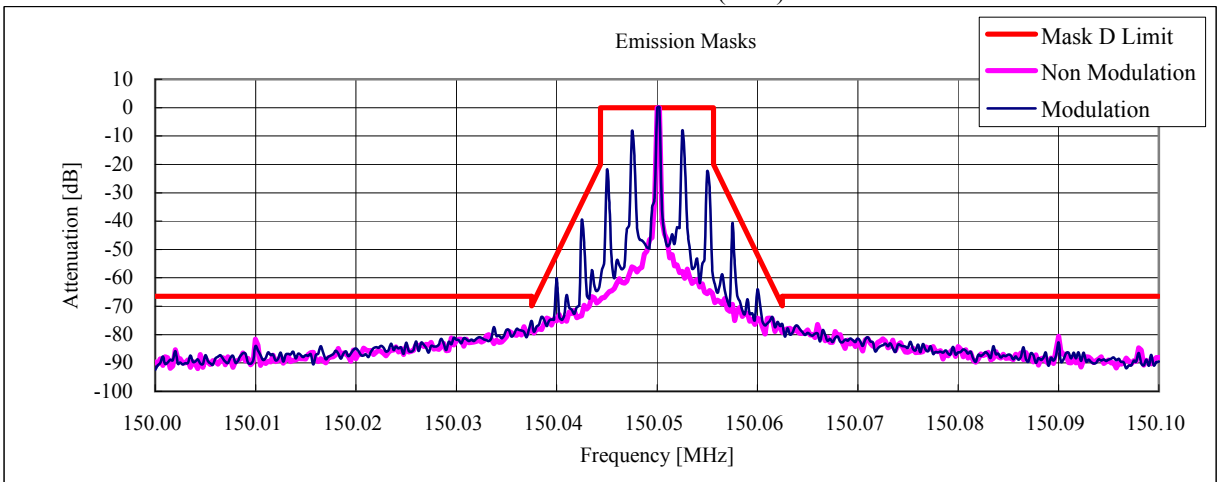

State : High Power / Authorized Bandwidth 20 kHz:FM / 138.05 MHz(RSS)

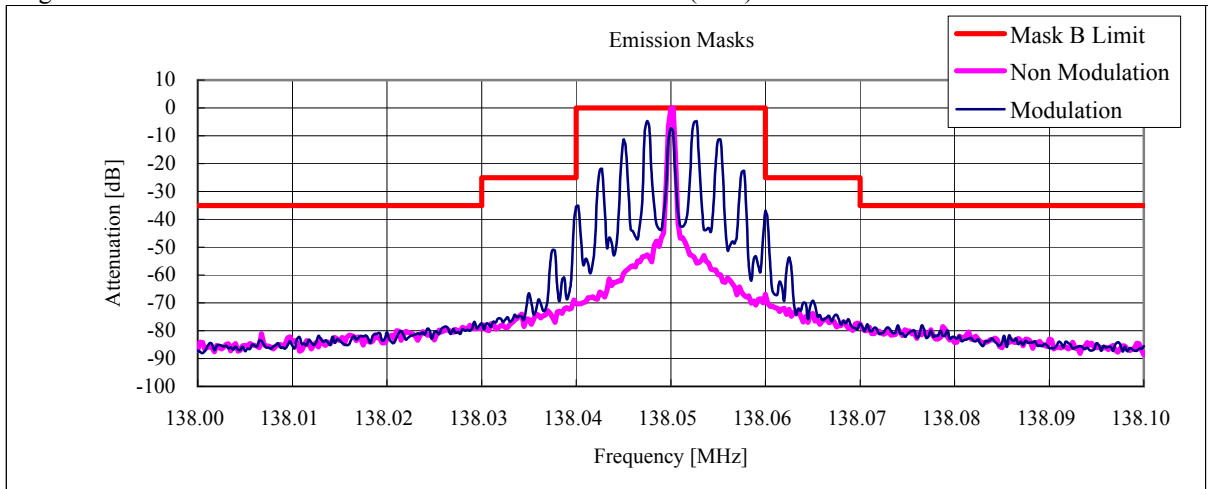

State : High Power / Authorized Bandwidth 11.25 kHz:FM / 138.05 MHz(RSS)

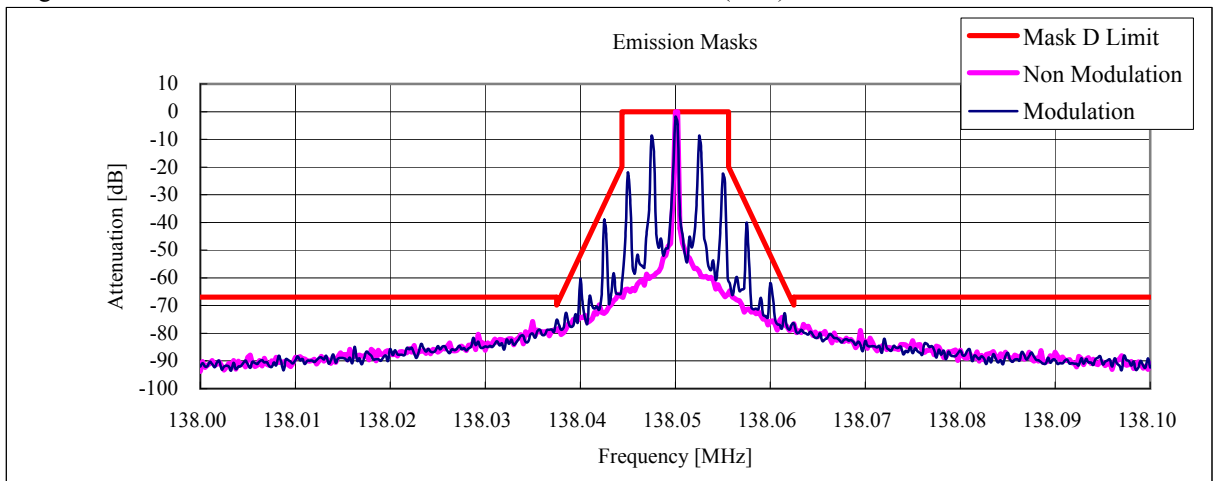

State : Low Power / Authorized Bandwidth 20 kHz:FM / 138.05 MHz(RSS)

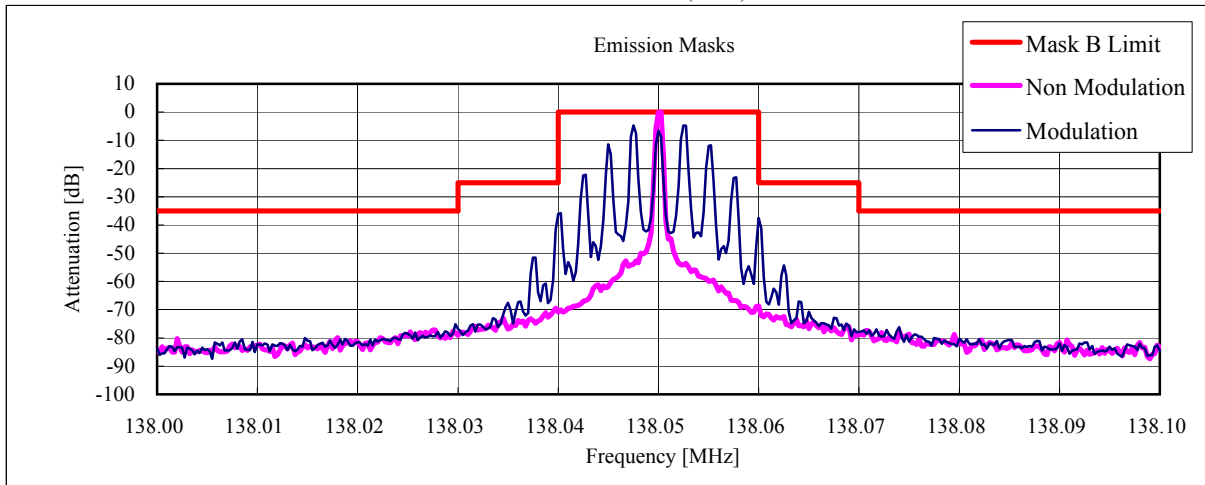

State : Low Power / Authorized Bandwidth 11.25 kHz:FM / 138.05 MHz(RSS)

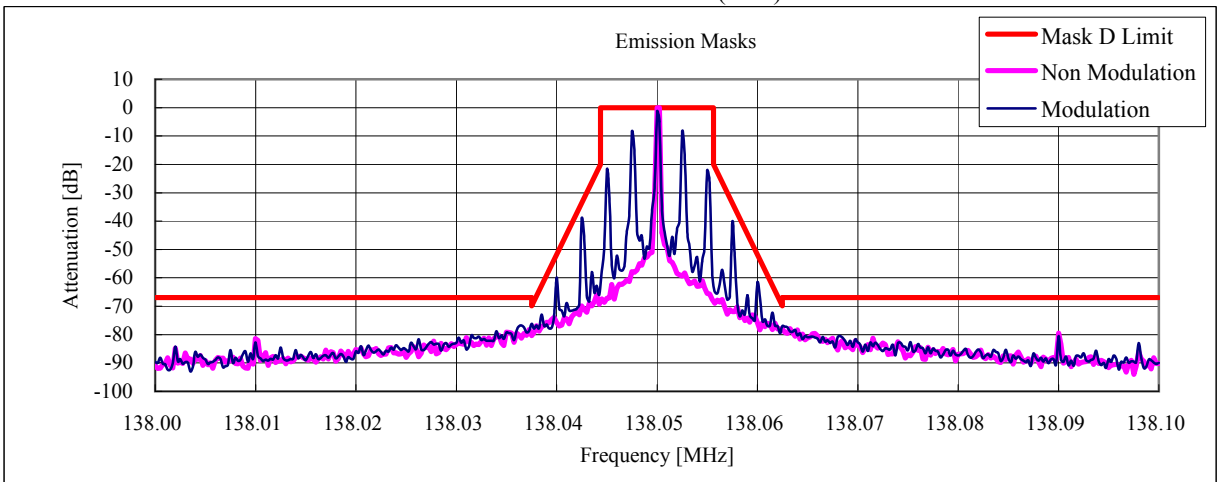

**10.5 Transient Frequency Behavior**

REGULATIONS : 47 CFR 90.214 / RSS-119 Section 5.9

TEST METHOD/GUIDE : ANSI/TIA-603-C Section 2.2.19.3

**Test Procedure**

## t Procedure

- 1 The EUT and test equipment were set up as shown on the following page.
- 2 The transmitter was turned on.
- 3 The transmitter carrier level was measured at the output of the combiner .
- 4 The transmitter was turned off.
- 5 An RF signal generator (1) modulated with a 1 kHz tone at either 25 kHz or 12.5 kHz or 6.25 kHz deviation, and set to the same frequency as the assigned transmitter frequency, (2) was adjusted to a level -30 dB below the level recorded in Procedure 3, as measured at the output of the combiner.  
This level was then fixed for the remainder of the test and is recorded at step h.
- 6 The oscilloscope was setup using TIA-603C steps j and k as a guide, and to 10 msec./div.
- 7 The transmitter was turned on, and the level of the carrier at the output of the combiner was recorded as step l.
- 8 The carrier on-time as referenced in TIA-603-C steps m, n, and o was captured and plotted.
- 9 The carrier off-time as referenced in TIA-603-C steps p, q, r, and s was captured and plotted.

No.	Equipment	Manufacture	Model No.	Serial No.	Cal Date	Cal Exp.
1	Signal Generator	Rohde&Schwarz	SMT06	100684	Dec. 12, 08	Dec. 31, 09
2	Oscilloscope	Tektronix	TDS 680B	B010292	Oct. 14, 08	Oct. 31, 09
3	Power Meter	Hewlett Packard	E4418B	GB38410265	May 26, 09	May. 31, 10
4	Power Sensor	Hewlett Packard	8482A	US37292237	May 26, 09	May. 31, 10
5	Attenuator (30dB)	Weinschel	WA-29-30-34	8923	May. 15, 09	May. 31, 10
6	Modulation Analyzer	Hewlett Packard	8901B	2806A01669	Feb. 23, 09	Feb. 28, 10
7	Combiner(1)	Anritsu	Z-164A	M89549	Oct. 09, 08	Oct. 31, 09
8	Combiner(2)	Anritsu	Z-164A	M89249	Oct. 09, 08	Oct. 31, 09
9	Attenuator (3dB)	TME	CFA-20NPJ-3	679701	May. 15, 09	May. 31, 10
10	Digital Multi Meter	Agilent	34401A	MY45028851	May. 27, 09	May. 31, 10
11	DC Power Supply	Daiwa	PS-3020	None	None	None

**Measuring Cables**

No.	Cable	Manufacture	Model No.	Serial No.	Cal Date	Cal Exp.
W1	Coaxial Cable	Suhner	SUCOFLEX104	KSR00091	May. 15, 09	May. 31, 10
W4	Coaxial Cable	Pacific custom	RG-58 C/U	AM90C02	Jan. 14, 09	Jan. 31, 10
W5	Coaxial Cable	Pacific custom	RG-58 C/U	AM90C03	Jan. 14, 09	Jan. 31, 10
W9	Coaxial Cable	Pacific custom	RG-58 C/U	KSR00094	Oct. 09, 08	Oct. 31, 09
W10	Coaxial Cable	Pacific custom	RG-58 C/U	KSR00095	Oct. 09, 08	Oct. 31, 09
W12	Coaxial Cable	Pacific custom	RG-58 C/U	AM90C04	Jan. 14, 09	Jan. 31, 10

**Measuring Equipment Configuration**

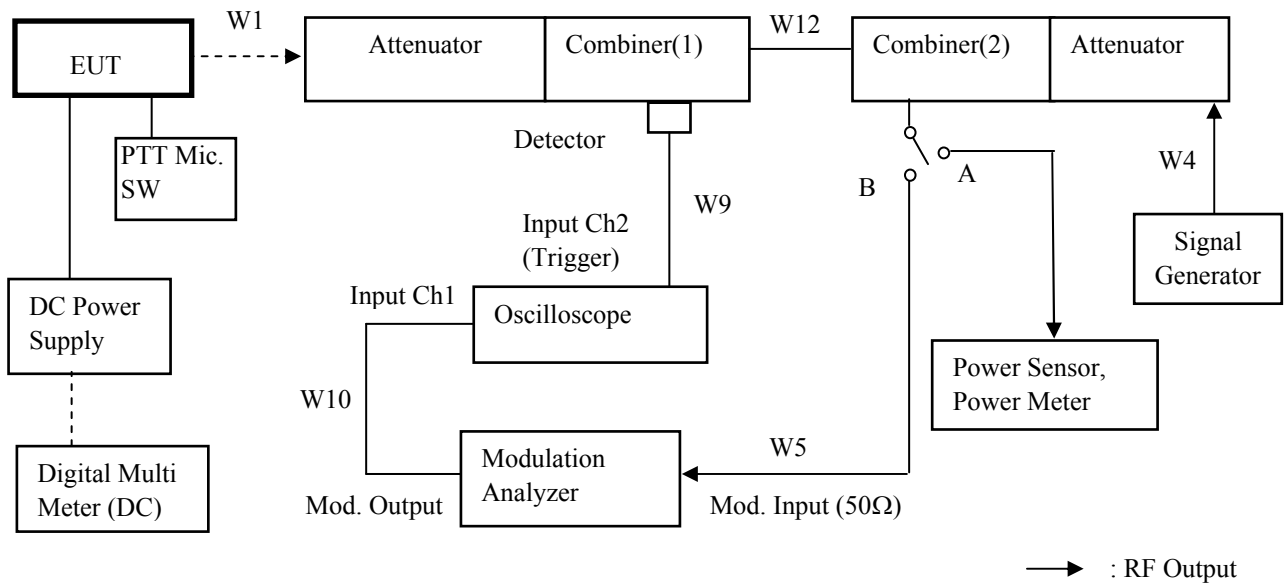

**Test Results**

Test date	Jul 9, 2009	to	Jul 10, 2009
Location	Kashima No.1 Test Site		
temperature	25.1 to 26.8	[degree C]	
Humidity Variation	49 to 66	[%]	
Atmospheric Pressure	99.4 to 100.1	[kPa]	
Test Engineer	Koichi Wagatsuma		

Test carried out for all the frequency band of section 10.1

Measured for the worst case

State : High Power / Authorized Bandwidth 20 kHz / 173.95 MHz(CFR / RSS )/ PTT:OFF -ON

Tek **Stop** Single Seq 5.00kS/s

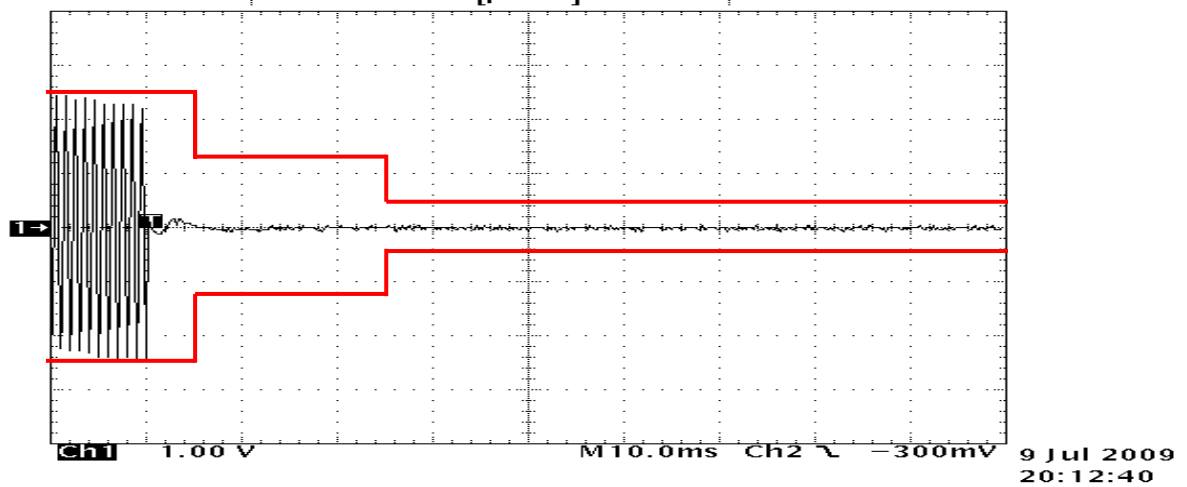

State : High Power / Authorized Bandwidth 20 kHz / 173.95 MHz(CFR / RSS )/ PTT:ON -OFF

Tek **Stop** Single Seq 5.00kS/s

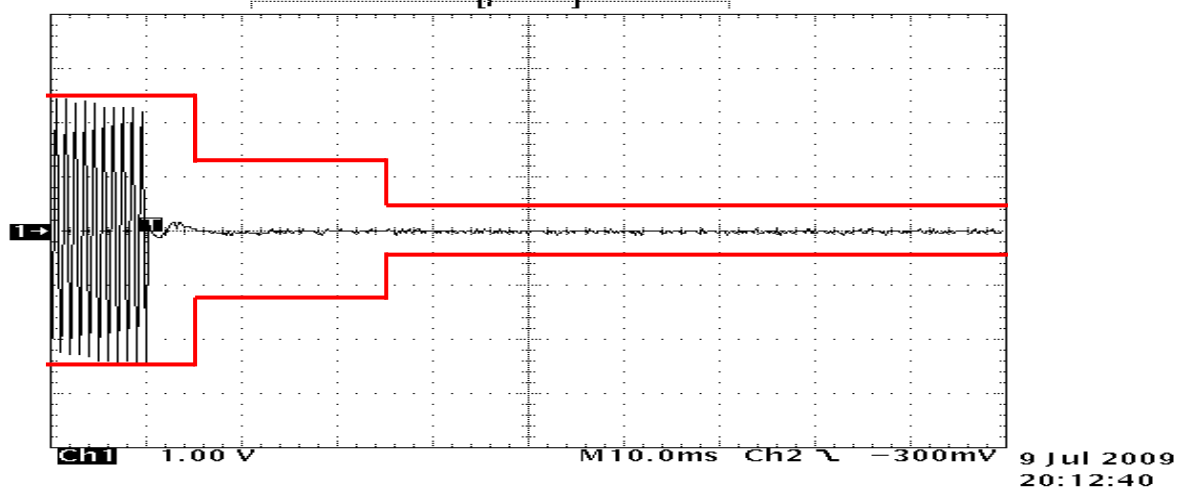

State : High Power / Authorized Bandwidth 11.25 kHz / 173.95 MHz(CFR / RSS ) / PTT:OFF -ON

Tek Stop: Single Seq 5.00kS/s

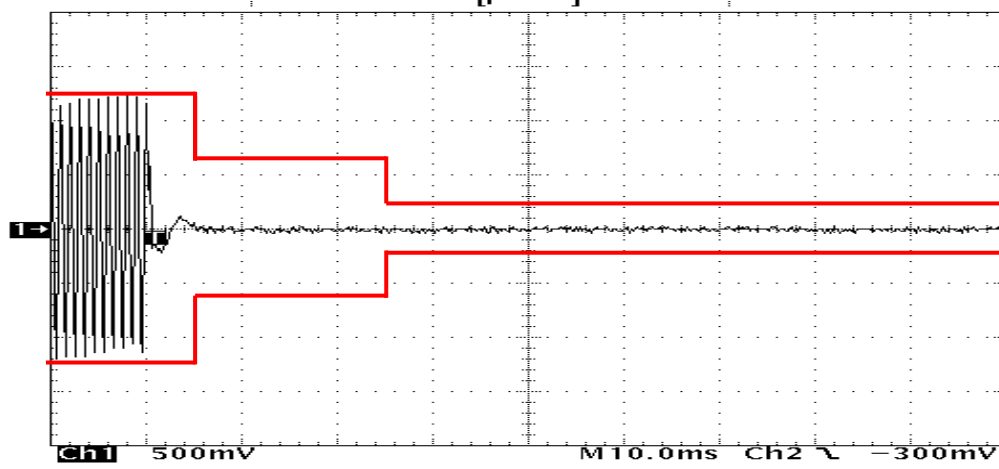

State : High Power / Authorized Bandwidth 11.25 kHz / 173.95 MHz(CFR / RSS ) / PTT:ON -OFF

Tek Run: 5.00kS/s Sample 1000

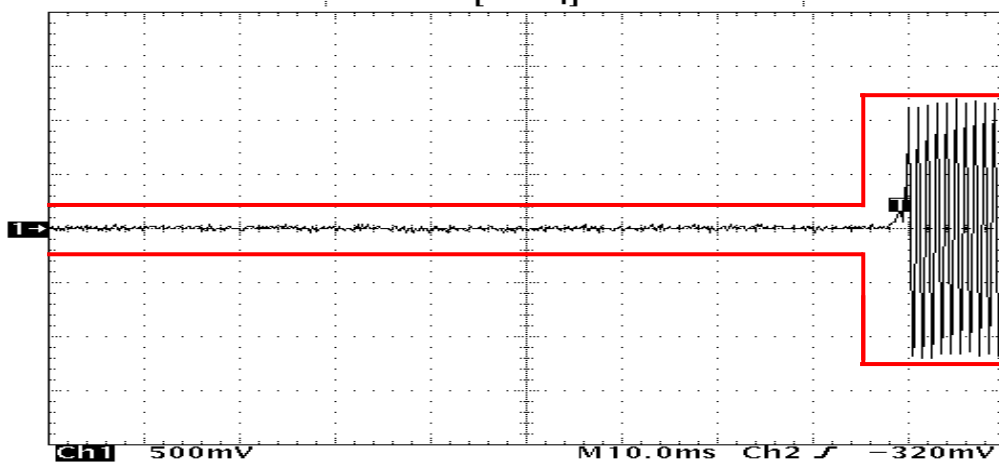

**10.6 Audio Frequency Response / Audio Low Pass Filter (Voice Input)**

REGULATIONS : 47 CFR 2.1047 (a) / RSS-119 Section 5.10

TEST METHOD/GUIDE : ANSI/TIA-603-C Section 2.2.6.2.2, 3.2.6.2 / RSS-119 Section 4.3

**Test Procedure**

- 1 The EUT and test equipment were set up as shown on the following page.
- 2 Adjust the Modulation Analyzer for the following setting:
  - a) High-pass filter : 50 Hz
  - b) Low-pass filter : 15 kHz
  - c) Detector : positive peak
  - d) Function : FM
- 3 The audio signal input was adjusted to obtain 20 % modulation at 1 kHz, and this point was taken as the 0 dB reference level.
- 4 With input levels held constant and below limiting at all frequencies, the audio signal generator was varied from 300 Hz to 5 kHz.
- 5 The response in dB relative to 1 kHz was then measured, using the Modulation Analyzer.

**Measuring Equipments**

No.	Equipment	Manufacture	Model No.	Serial No.	Cal Date	Cal Exp.
1	Audio Generator	Anritsu	MG443B	M70150	Apr. 01, 09	Apr. 30, 10
2	Audio Analyzer	Hewlett Packard	8903B	2818A04372	Apr 10, 09	Apr. 30, 10
3	Attenuator (20dB)	Aeroflex/Wenshel	66-20-34	BY4537	Mar. 30, 09	Mar. 31, 10
4	Attenuator (30dB)	Weinschel	WA-29-30-34	8923	May. 15, 09	May. 31, 10
5	Modulation Analyzer	Hewlett Packard	8901B	2806A01669	Feb. 23, 09	Feb. 28, 10
6	Digital Multi Meter	Agilent	34401A	MY45028851	May. 27, 09	May. 31, 10
7	DC Power Supply	Daiwa	PS-3020	None	None	None

**Measuring Cables**

No.	Cable	Manufacture	Model No.	Serial No.	Cal Date	Cal Exp.
W1	Coaxial Cable	Suhner	SUCOFLEX104	KSR00091	May. 15, 09	May. 31, 10
W6	Balance Cable	Nicoon	3D-2V	KSR00092	Oct. 09, 08	Oct. 31, 09
W9	Coaxial Cable	Pacific custom	RG-58 C/U	KSR00094	Oct. 09, 08	Oct. 31, 09
W10	Coaxial Cable	Pacific custom	RG-58 C/U	KSR00095	Oct. 09, 08	Oct. 31, 09



### Measuring Equipment Configuration

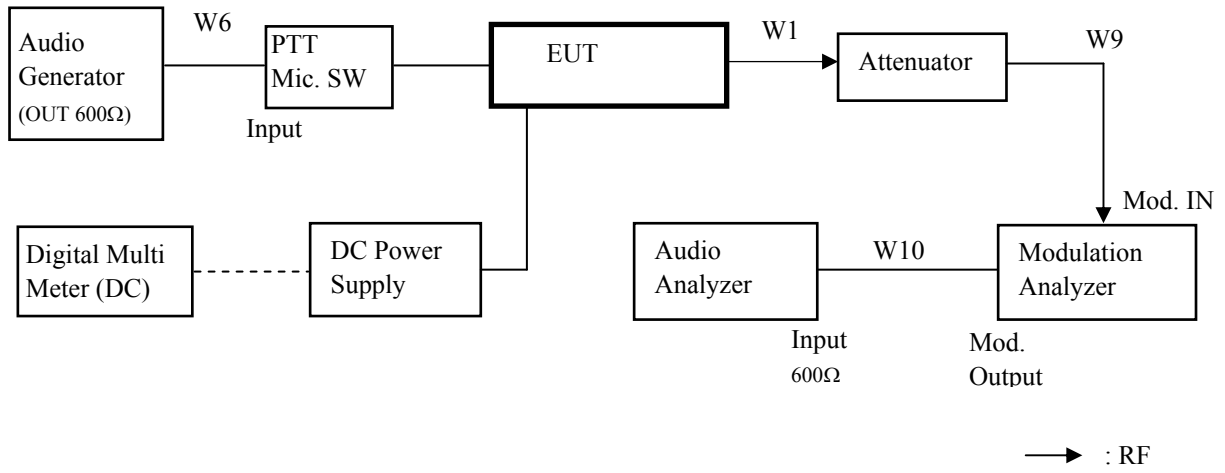

**Test Results**

Test date	Jul 6, 2009	
Location	Kashima No.1 Test Site	
temperature	24.2 to 24.8	[degree C]
Humidity Variation	67 to 71	[%]
Atmospheric Pressure	100.7 to 101.0	[kPa]
Test Engineer	Koichi Wagatsuma	

Test carried out for all the frequency band of section 10.1

Measured for the worst case

State : High Power / Authorized Bandwidth 20 kHz / 173.95 MHz (CFR / RSS)

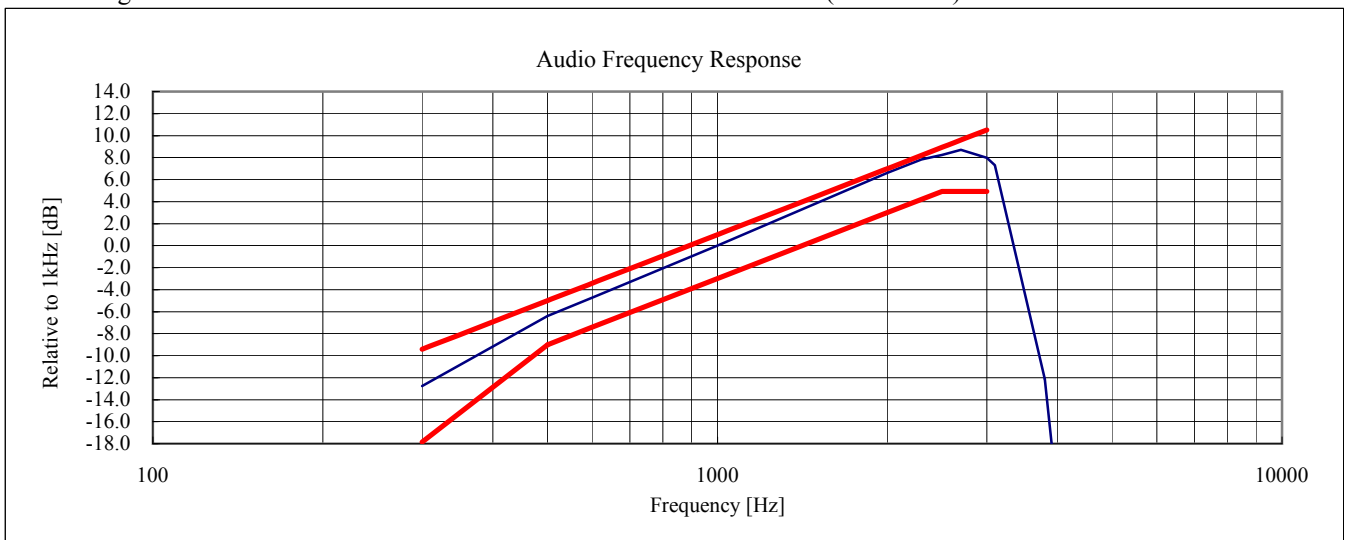

State : High Power / Authorized Bandwidth 11.25 kHz / 173.95 MHz (CFR / RSS)

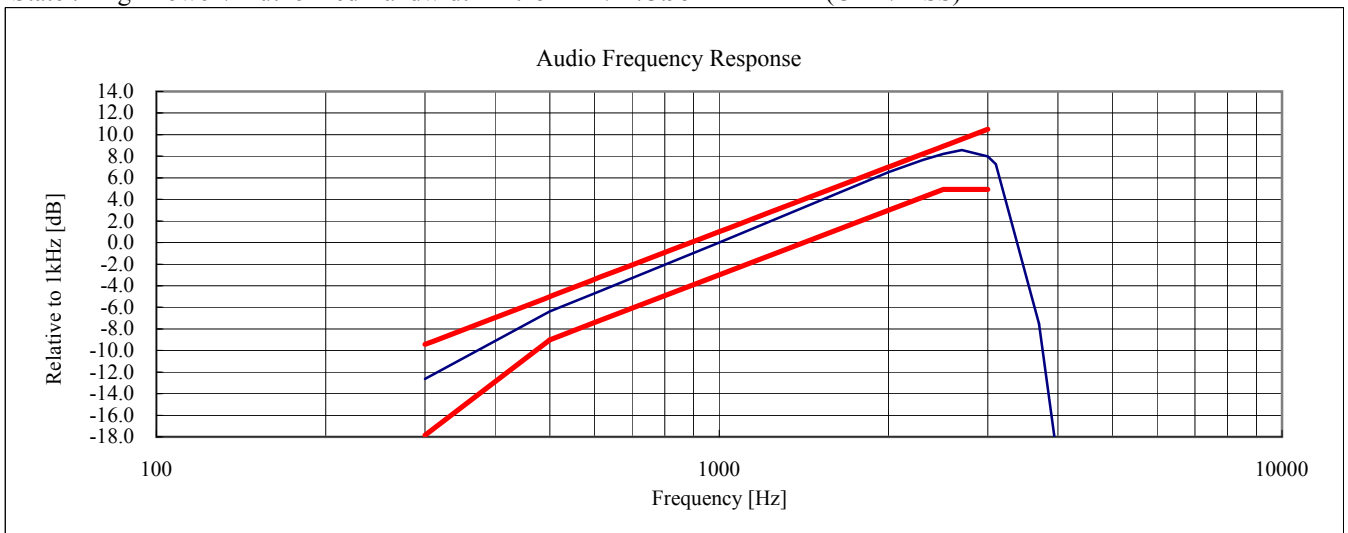

Note:

Audio Filter of the above result is substituted with the same structure as Audio Frequency Resonse.

On the transmission condition below 3kHz, Transceiver shows pre-emphasis condition of transmission function.

On the transmission condition above 3kHz, Transceiver shows Audio Low Pass Filter.

**10.7 Modulation Limiting**

REGULATIONS	: 47 CFR 2.1047 (b) / RSS-119 Section 5.10
TEST METHOD/GUIDE	: ANSI/TIA-603-C Section 2.2.3.2, 1.3.4.4 / RSS-119 Section 4.3

**Test Procedure**

- 1 The EUT and test equipment were set up as shown on the following page.
- 2 Adjust the Modulation Analyzer for the following setting:
  - a) High-pass filter : off
  - b) Low-pass filter : 15 kHz
  - c) Detector : positive peak
  - d) Function : FM
- 3 Apply a 1kHz modulation signal to the transmitter from the audio generator, and adjust the level to obtain 60% of full rated system deviation.
- 4 Measure the modulation frequency that was showed on the Modulation Analyzer when the output levels of the Audio Generator were changed from -20 dB to +50 dB by 10 dB.
- 5 Set the output frequencies of the Audio Generator 300 Hz and 3 kHz, and repeat test procedure 4.
- 6 Set the the Detector of the Modulation Analyzer Negative Peak.
- 7 Repeat test procedure 4 and 5.

**Measuring Equipments**

No.	Equipment	Manufacture	Model No.	Serial No.	Cal Date	Cal Exp.
1	Audio Generator	Anritsu	MG443B	M70150	Apr. 01, 09	Apr. 30, 10
2	Attenuator (20dB)	Aeroflex/Wenshel	66-20-34	BY4537	Mar. 30, 09	Mar. 31, 10
3	Attenuator (30dB)	Weinschel	WA-29-30-34	8923	May. 15, 09	May. 31, 10
4	Modulation Analyzer	Hewlett Packard	8901B	2806A01669	Feb. 23, 09	Feb. 28, 10
5	Digital Multi Meter	Agilent	34401A	MY45028851	May. 27, 09	May. 31, 10
6	DC Power Supply	Daiwa	PS-3020	None	None	None

**Measuring Cables**

No.	Cable	Manufacture	Model No.	Serial No.	Cal Date	Cal Exp.
W1	Coaxial Cable	Suhner	SUCOFLEX104	KSR00091	May. 15, 09	May. 31, 10
W6	Balance Cable	Nicoon	3D-2V	KSR00092	Oct. 09, 08	Oct. 31, 09
W9	Coaxial Cable	Pacific custom	RG-58 C/U	KSR00094	Oct. 09, 08	Oct. 31, 09

### Measuring Equipment Configuration

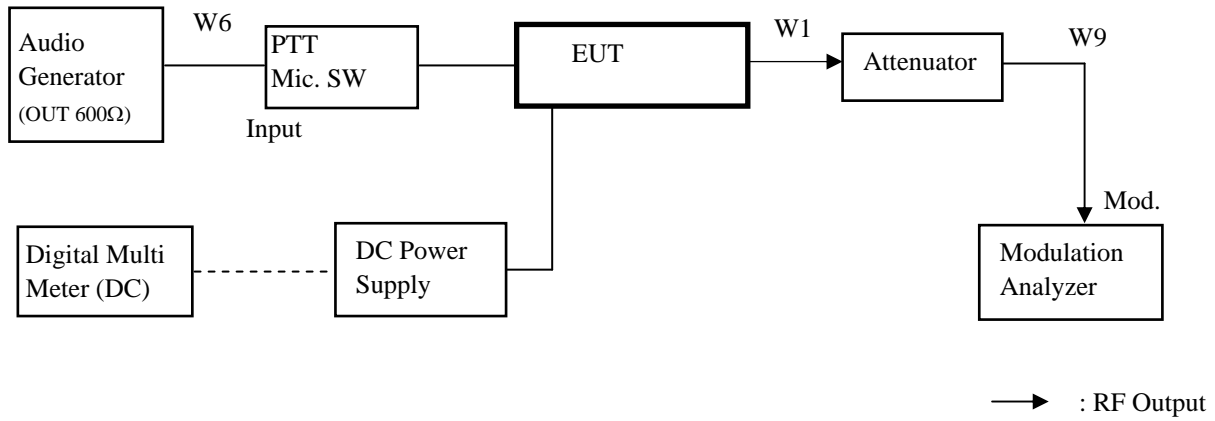

**Test Results**

Test date	Jul 3, 2009	
Location	Kashima No.1 Test Site	
temperature	24.1 to 24.7	[degree C]
Humidity Variation	66 to 67	[%]
Atmospheric Pressure	100.1 to 100.4	[kPa]
Test Engineer	Koichi Wagatsuma	

Test carried out for all the frequency band of section 10.1

Measured for the worst case

State : High Power / Authorized Bandwidth 20 kHz / 162.05 MHz (CFR)

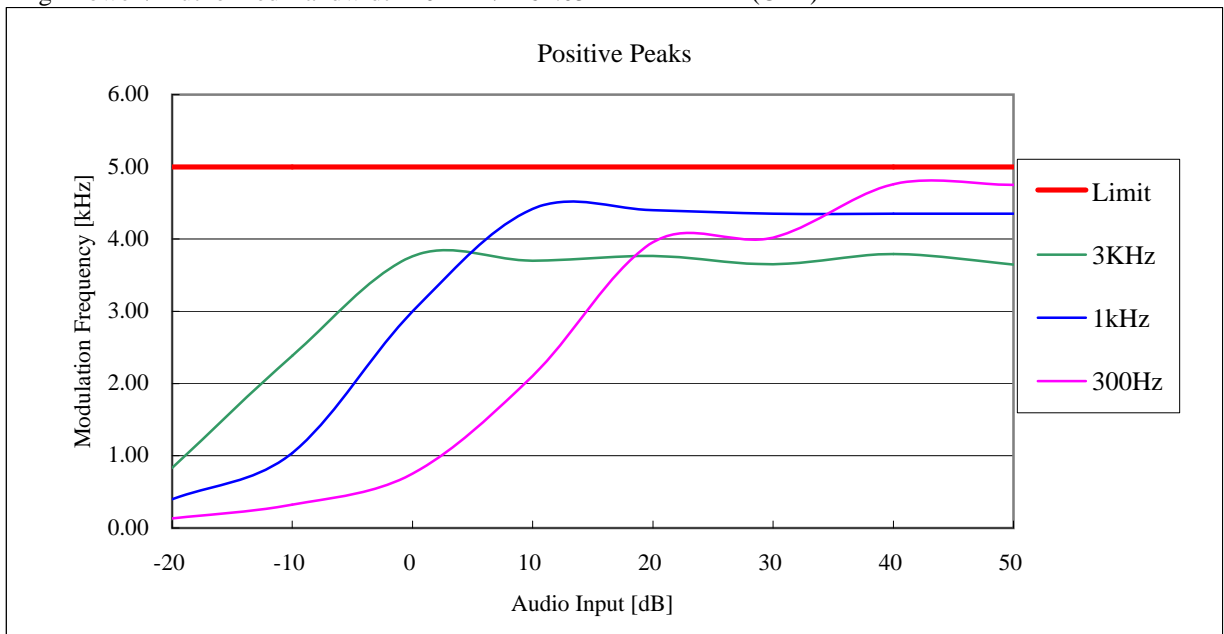

State : High Power / Authorized Bandwidth 20 kHz / 162.05 MHz (CFR)

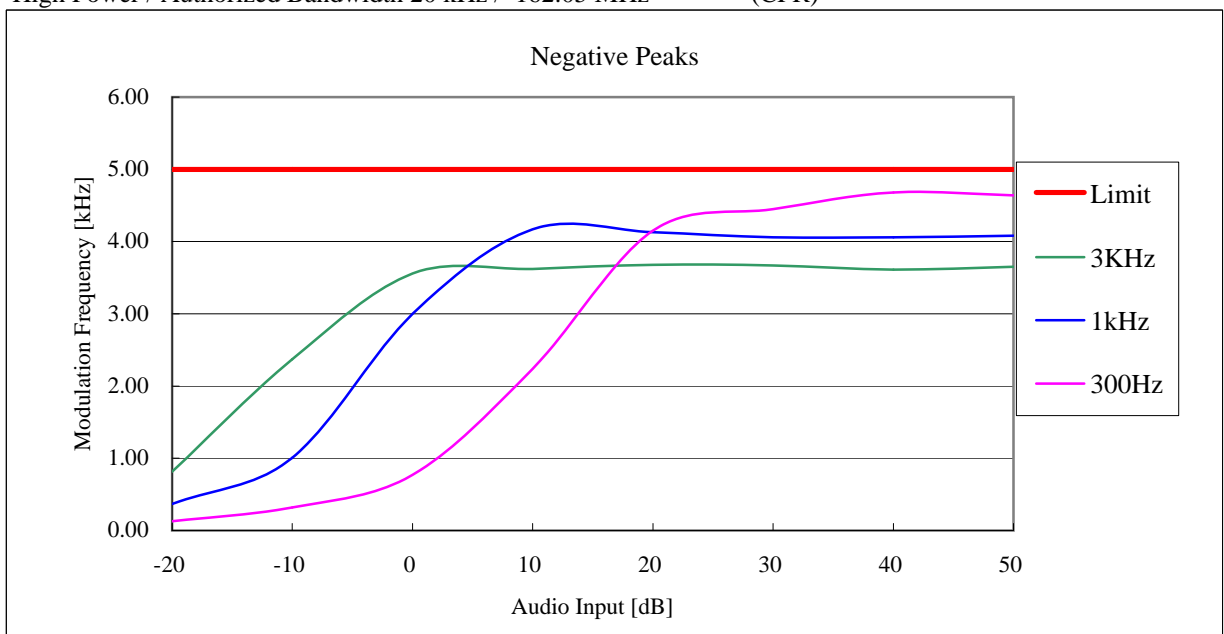

State : High Power / Authorized Bandwidth 11.25 kHz / 162.05 MHz (CFR)

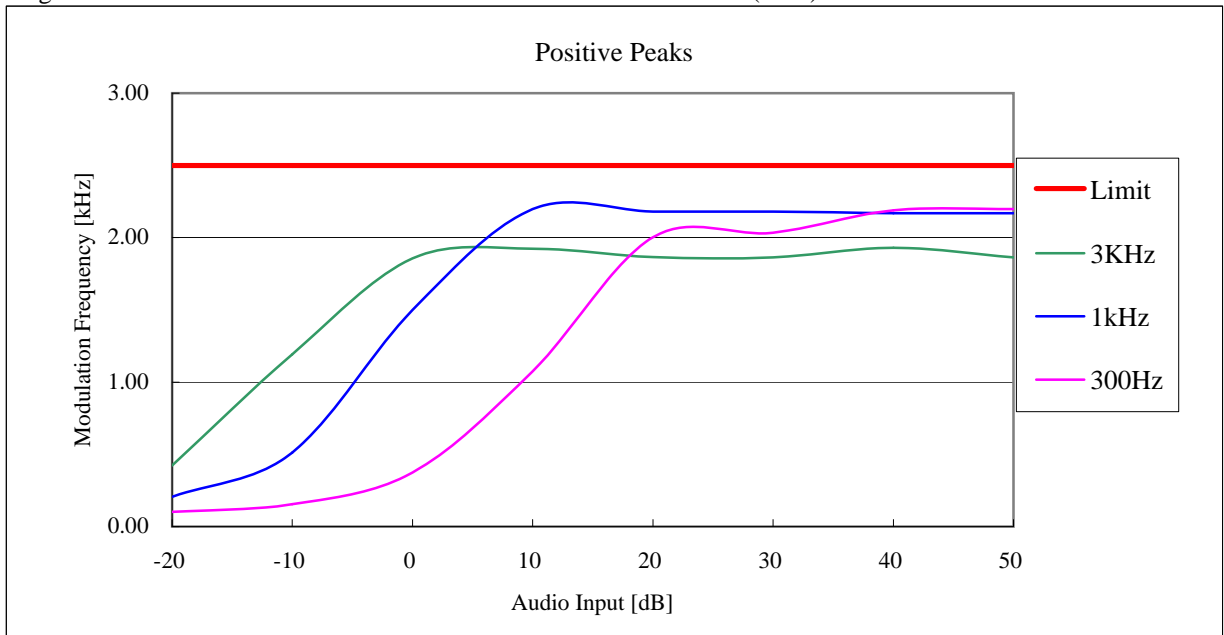

State : High Power / Authorized Bandwidth 11.25 kHz / 162.05 MHz (CFR)

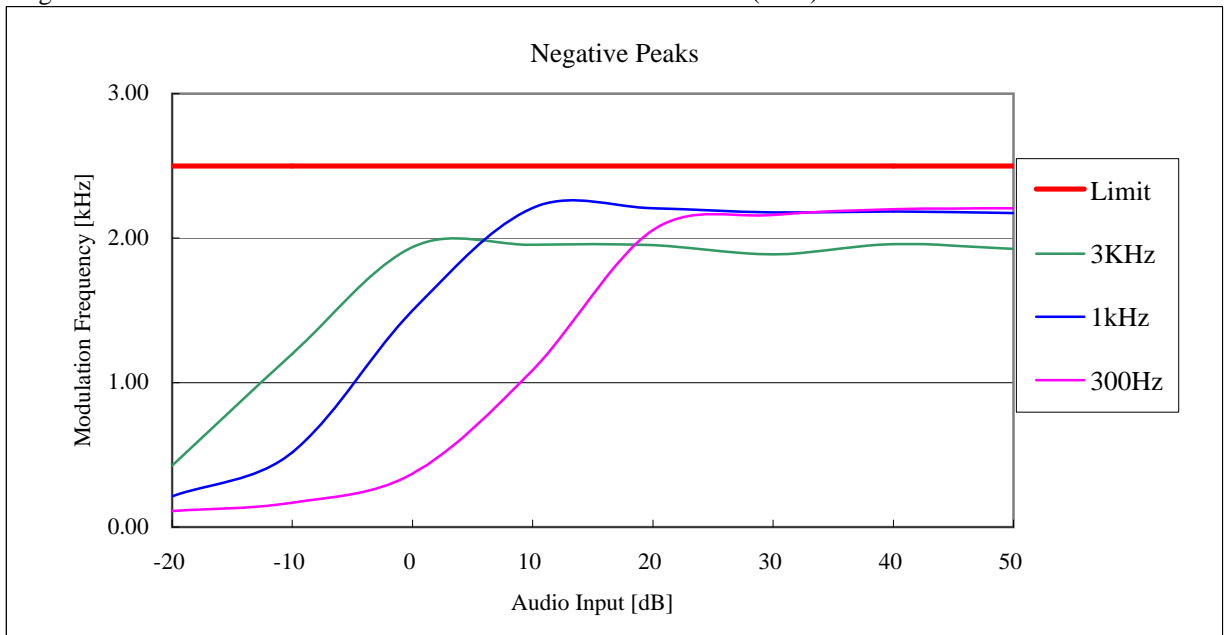

State : High Power / Authorized Bandwidth 20 kHz / 138.05 MHz (RSS)

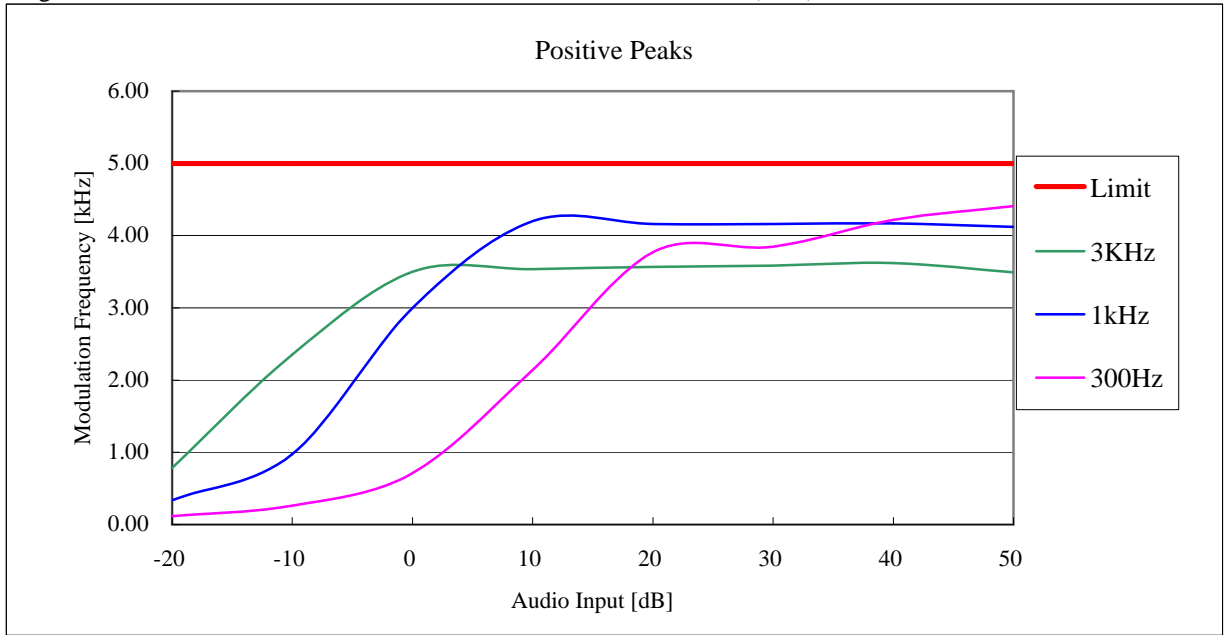

State : High Power / Authorized Bandwidth 20 kHz / 138.05 MHz (RSS)

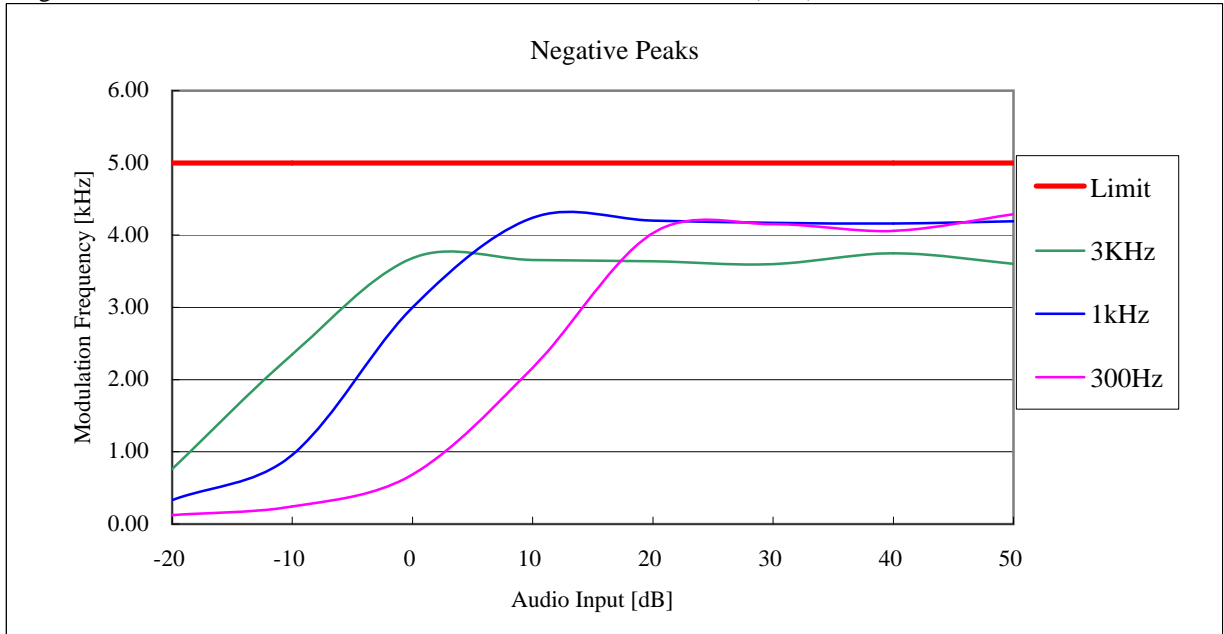

State : High Power / Authorized Bandwidth 11.25 kHz / 138.05 MHz (RSS)

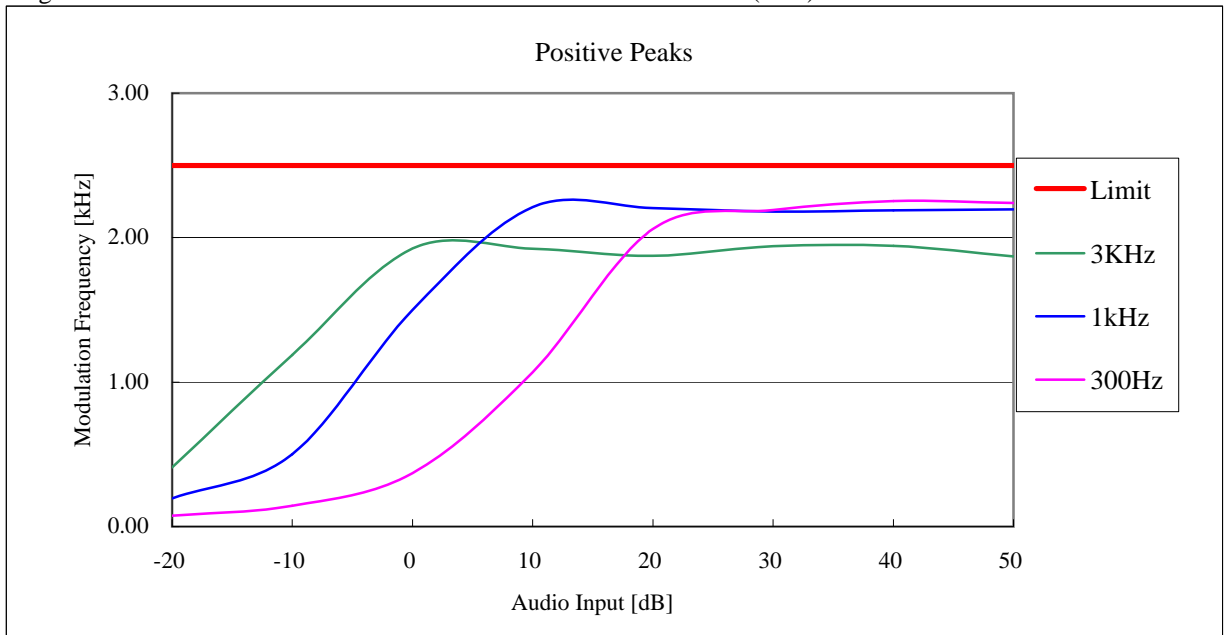

State : High Power / Authorized Bandwidth 11.25 kHz / 138.05 MHz (RSS)

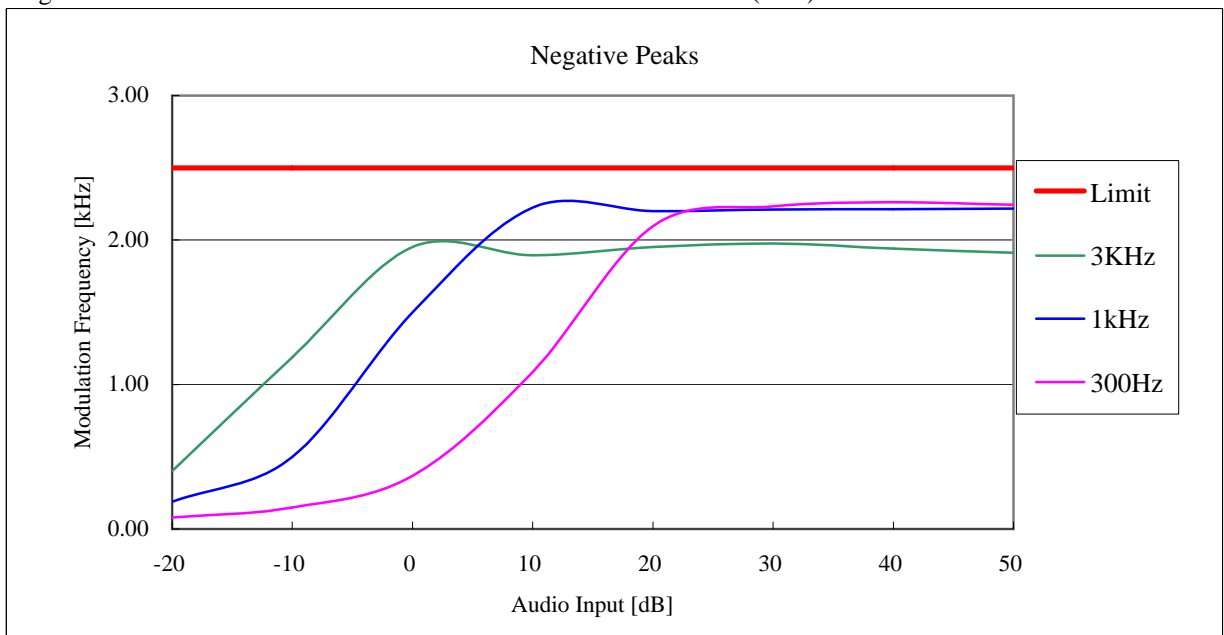



**10.8 Frequency Stability (Temperature Variation)**

REGULATIONS : 47 CFR 2.1055 (a) (1), 22.355 , 74.464 , 90.213(a) / RSS-119 Section 5.3

TEST METHOD/GUIDE : ANSI/TIA-603-C Section 2.2.2.2 / RSS-Gen Section 4.7(a)

**Test Procedure**

- 1 The EUT and test equipment were set up as shown on the following page.
- 2 Set the temperature -30 degrees C.
- 3 Leave the EUT for 1 hour after it became the temperature that was set up.
- 4 Make the EUT the transmitting state.  
Two minutes later, measure the output frequency.
- 5 Make the EUT the receiving state.
- 6 Set the temperature 50 degrees C by 10 degrees C.  
And repeat test procedure 3 to 5.

**Measuring Equipments**

No.	Equipment	Manufacture	Model No.	Serial No.	Cal Date	Cal Exp.
1	Attenuator (30dB)	Weinschel	WA-29-30-34	8923	May. 15, 09	May. 31, 10
2	Attenuator (20dB)	Aeroflex/Wenshel	66-20-34	BY4537	Mar. 30, 09	Mar. 31, 10
3	Spectrum Analyzer	Agilent	E4407B	MY45102460	Feb. 09, 09	Feb. 28, 10
4	Digital Multi Meter	FLUKE	8846A	9642018	Jul. 06, 09	Jul. 31, 10
5	DC Power Supply	Micky	10A	None	None	None
6	DC Power Supply	Daiwa	PS-3020	None	None	None
7	Temperature Chamber	Tabai	PL-3F	5103661	None	None
8	Temperature Meter	Sato	PC-5000TRH-II	A11999972	Apr. 10, 09	Apr. 30, 10

**Measuring Cables**

No.	Cable	Manufacture	Model No.	Serial No.	Cal Date	Cal Exp.
W2	Coaxial Cable	Suhner	SUCOFLEX104	KSR00046	Jan. 14, 09	Jan. 31, 10
W3	Coaxial Cable	Suhner	SUCOFLEX104	KSR00042	Mar. 12, 09	Mar. 31, 10

### Measuring Equipment Configuration

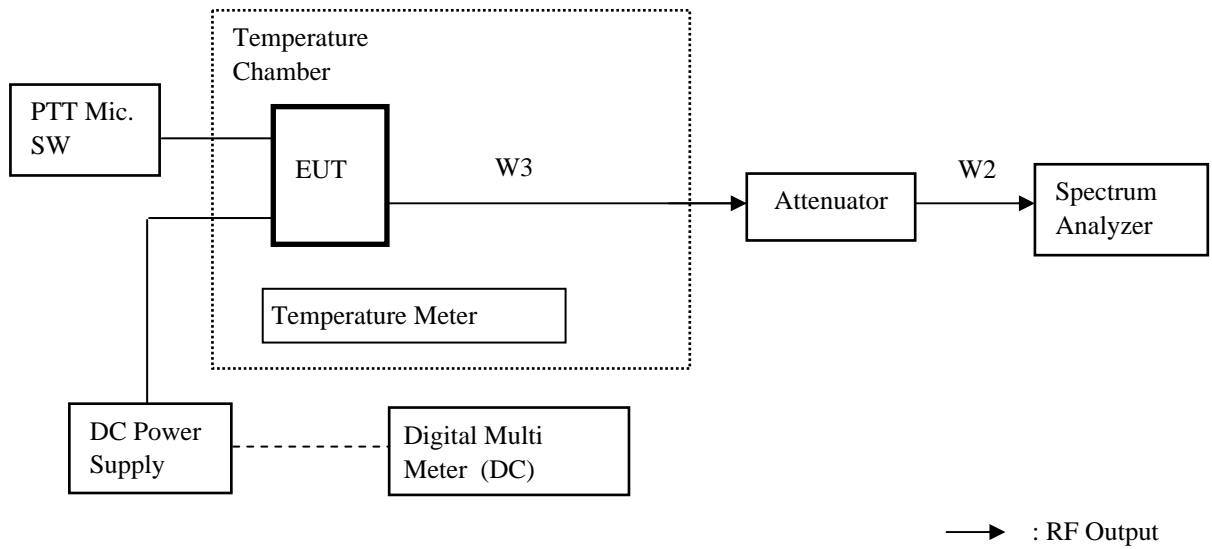

**Test Results**

Test date	Jul 23, 2009	to	Jul 24, 2009
Location	Kashima No.1 Test Site		
Test Engineer	Koichi Wagatsuma		

Test carried out for all the frequency band of section 10.1

Measured for the worst case

State : High Power / Authorized Bandwidth 11.25 kHz / 173.95 MHz (CFR / RSS)

No.	Temperature (Degree C)	Frequency (MHz)	Stability (ppm)	RSS Deviation	Limit (+/- ppm)	Min. Margin (ppm)
1	-30	173.949958	-0.24	0.03	2.5	2.26
2	-20	173.949960	-0.23	0.04	2.5	2.27
3	-10	173.949960	-0.23	0.04	2.5	2.27
4	0	173.949958	-0.24	0.03	2.5	2.26
5	10	173.949957	-0.25	0.02	2.5	2.25
6	20	173.949953	-0.27	0.00	2.5	2.23
7	30	173.949942	-0.33	-0.06	2.5	2.17
8	40	173.949932	-0.39	-0.12	2.5	2.11
9	50	173.949920	-0.46	-0.19	2.5	2.04

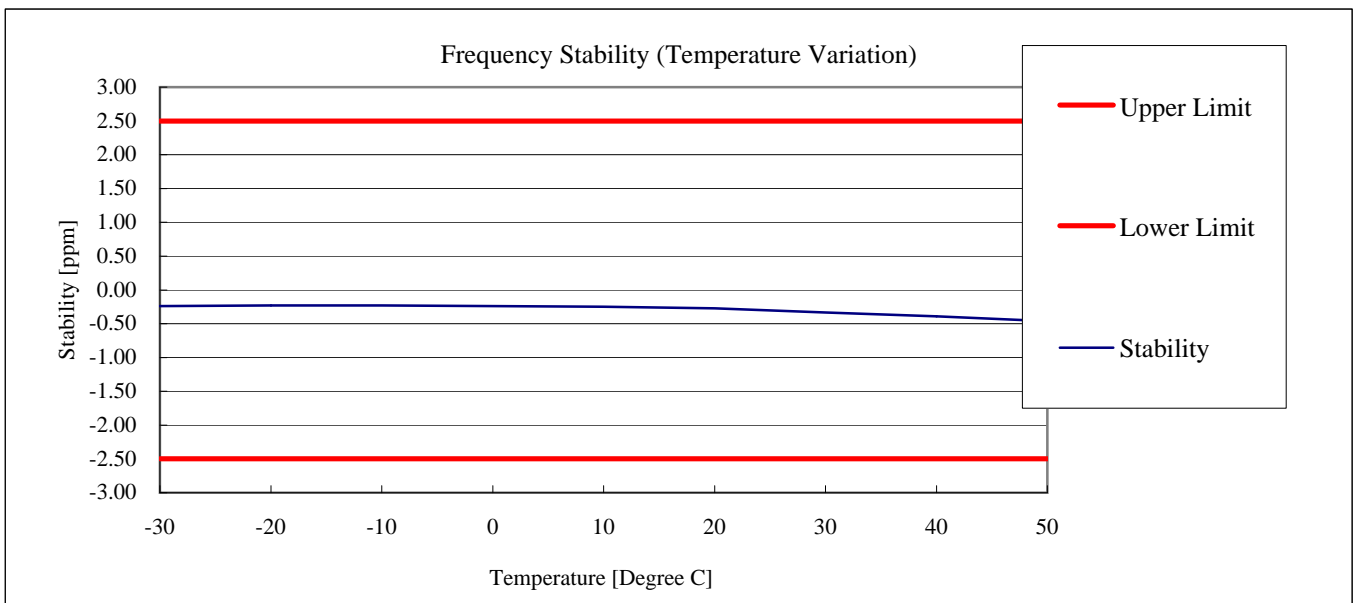

**10.9 Frequency Stability (Voltage Variation)**

REGULATIONS	: 47 CFR 2.1055 (d) (1), 22.355 , 74.464 , 90.213(a)
TEST METHOD/GUIDE	: ANSI/TIA-603-C Section 2.2.2.2

**Test Procedure**

- 1 The EUT and test equipment were set up as shown on the following page.
- 2 The power supply voltage to the EUT was varied from 85 % to 115 % of the nominal value measured at the input to the EUT.

**Measuring Equipments**

No.	Equipment	Manufacture	Model No.	Serial No.	Cal Date	Cal Exp.
1	Attenuator (30dB)	Weinschel	WA-29-30-34	8923	39948	May. 31, 10
2	Attenuator (20dB)	Aeroflex/Wenshel	66-20-34	BY4537	Mar. 30, 09	Mar. 31, 10
3	Spectrum Analyzer	Agilent	E4407B	MY45102460	Feb. 09, 09	Feb. 28, 10
4	Digital Multi Meter	FLUKE	8846A	9642018	Jul. 06, 09	Jul. 31, 10
5	DC Power Supply	Micky	10A	None	None	None
6	DC Power Supply	Daiwa	PS-3020	None	None	None
7	Temperature Chamber	Tabai	PL-3F	5103661	None	None
8	Temperature Meter	Sato	PC-5000TRH-II	A11999972	Apr. 10, 09	Apr. 30, 10

**Measuring Cables**

No.	Cable	Manufacture	Model No.	Serial No.	Cal Date	Cal Exp.
W2	Coaxial Cable	Suhner	SUCOFLEX104	KSR00046	Jan. 14, 09	Jan. 31, 10
W3	Coaxial Cable	Suhner	SUCOFLEX104	KSR00042	Mar. 12, 09	Mar. 31, 10

**Measuring Equipment Configuration**

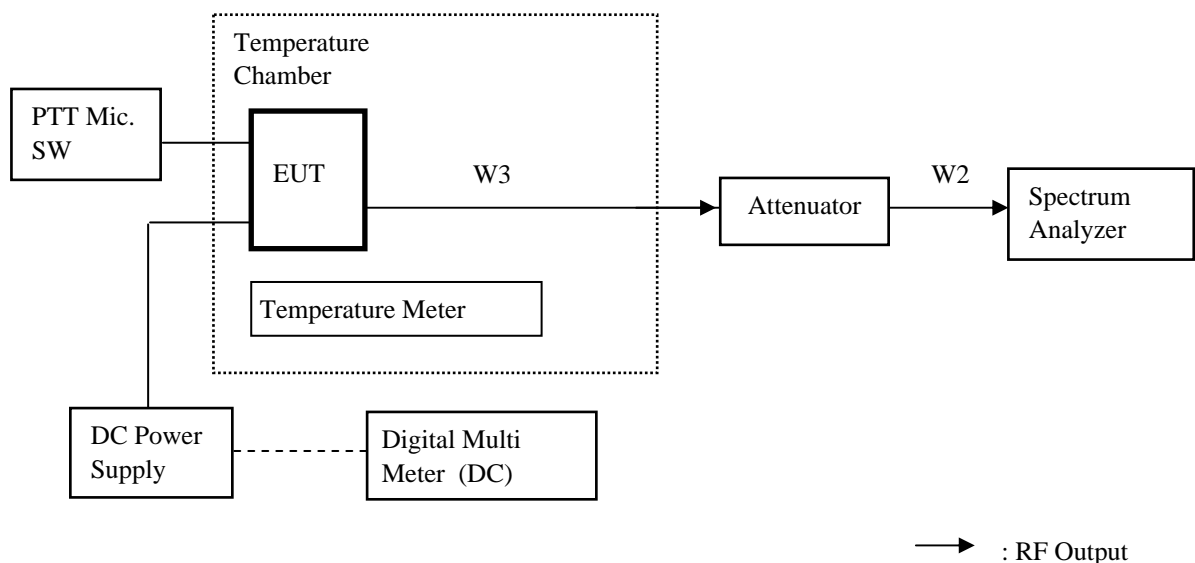

**Test Results**

Test date	Jul 23, 2009 to Jul 24, 2009
Location	Kashima No.1 Test Site
Test Engineer	Koichi Wagatsuma

Test carried out for all the frequency band of section 10.1  
 Measured for the worst case

State : High Power / Authorized Bandwidth 20 kHz / 173.95 MHz (CFR / RSS)

No.	Diviation (%)	Voltage (V)	Frequency (MHz)	Stability (ppm)	Limit +/- (ppm)	Margin (ppm)
1	85	11.56	173.949952	-0.28	2.5	2.22
2	100	13.60	173.949951	-0.28	2.5	2.22
3	115	15.64	173.949945	-0.32	2.5	2.18

**10.10 Receiver Spurious Emissions(Radiated)**

REGULATIONS	:	RSS-119 Section 5.11, RSS-Gen Section 6
-------------	---	---

TEST METHOD/GUIDE	:	RSS-Gen Section 4.10
-------------------	---	----------------------

**TEST PROCEDURE**

- 1 The EUT and test equipment were set up as shown on the following page.
- 2 Tabletop Equipment  
EUT is placed on the wooden table, the top of which is 0.8meter above the metal ground plane(turntable).
- 3 Interconnecting Cables  
Excess part of the interconnecting cables longer than 1 meter are bundled in the center.  
Cables that hang closer than 40 cm to the ground plane is folded back and forth forming bundle 30 to 40 cm long,
- 4 Measuring Instruments  
Measuring instruments list and their calibration schedule are shown on Measurement Equipment Configuration.  
The brief description are as follows;
- 5 Antennas  
The broadband Bi-cog antenna is used for measurement on the frequency range 30 – 1000 MHz.  
The Double ridged guide antenna is used for frequency higher than 1000 MHz
- 6 Pre-amplifier  
The broadband pre-amplifier is used for radiated emission measurement.  
The signal to noise ratio is improved by using pre-amplifier.
- 7 Spectrum Analyzer  
The spectrum analyzer is used for preliminary measurement of frequency range 30 – 1000 MHz, and also used for final measurement of higher than 1000 MHz (RBW : 1 MHz).
- 8 EMI Test Receiver  
The Quasi-peak detector (IF bandwidth : 120 kHz) built in test receiver is used for final measurement of the frequency 30 – 1000 MHz.  
The test receiver is complied with the specification of the CISPR publication 16.
- 9 Turntable  
The turntable is capable for EUT weight and rotatable 0 to 360 degree horizontally by remote control in the test room.
- 10 Antenna Mast  
The antenna mast is attachable to all antennas described on antenna height is adjustable 1 to 4 meters continuously by remote control at the test room, and antenna polarization is also changed by the remote control.  
Preliminary Measurement
- 11 EUT is tested on all operating conditions.  
The spectrum analyzer is set max-hold mode and swept during turntable was rotated 0 to 360 degree. Then spectrum chart are plotted out to find the worst emission conditions in configuration, operating mode, or ambient noise notation.

## 12 Final Measurement

The EUT operated in the condition where maximum emission is found in the preliminary test.

The turntable azimuth(EUT direction) and antenna height are adjusted the position so that maximum field strength is obtained for each frequency spectrum to be measured.

The equipment and cables are arranged or manipulated within the range of the test standard in the above condition.

When the uncertain result was obtained, the measurement is retried by using the half wave dipole antenna instead of the broadband antenna

**TEST EQUIPMENTS**

No.	Equipment	Manufacture	Model No.	Serial No.	Cal Date	Cal Exp.
1	Tri-log Antenna	Schwarzbeck	VULB9168WP	287	Nov. 18, 08	Nov. 30, 09
2	D.R.G Antenna	Schwarzbeck	3117	KSR00038	Aug. 06, 08	Aug. 31, 09
3	Step Attenuator	Hewlett Packard	8464B	2726A14513	Jan. 14, 09	Jan. 31, 10
4	Pre-Amplifier	Intertek Japan	ZX60-3018G	001	Nov. 12, 08	Nov. 30, 09
5	Pre-Amplifier	Hewlett Packard	83051A	3332A00329	Oct. 31, 08	Oct. 31, 09
6	Attenuator (6dB)	Anritsu	MP721B	M57593	Nov. 12, 08	Nov. 30, 09
7	Attenuator(3dB)	Narda	4768-3	79	Oct. 31, 08	Oct. 31, 09
8	Spectrum Analyzer	Hewlett Packard	8564E	3643A00665	May 08, 09	May. 31, 10
9	Test Receiver	Rohde & Schwarz	ESS	844861/004	Jun. 11, 09	Jun. 30, 10
10	Dummy Load	TME	CT-150NP	1138693	Sep. 09, 08	Sep. 30, 09
11	DC Power Supply	Daiwa	PS-3020	None	None	None
12	Digital Multi Meter	FLUKE	8846A	9642018	Jul. 06, 09	Jul. 31, 10

**USED CABLES**

No.	Cable	Manufacture	Model No.	Serial No.	Cal Date	Cal Exp.
R1	Coaxial Cable	Intertek Japan	5D-2W	None	Nov. 12, 08	Nov. 30, 09
R2	Coaxial Cable	Intertek Japan	10D-2W	None	Nov. 12, 08	Nov. 30, 09
R3	Coaxial Cable	Intertek Japan	5D-2W	None	Nov. 12, 08	Nov. 30, 09
R4	Coaxial Cable	Intertek Japan	5D-2W	None	Nov. 12, 08	Nov. 30, 09
R5	Coaxial Cable	Intertek Japan	5D-2W	None	Nov. 12, 08	Nov. 30, 09
R6	Coaxial Cable	Intertek Japan	5D-2W	None	Nov. 12, 08	Nov. 30, 09
R7	Coaxial Cable	Intertek Japan	5D-2W	None	Nov. 12, 08	Nov. 30, 09
R14	Coaxial Cable	Suhner	SUCOFLEX102	712/2	Oct. 31, 08	Oct. 31, 09
R15	Coaxial Cable	Insulated Wire	KSP-1501-1969- KPS	3292004	Oct. 31, 08	Oct. 31, 09

### MEASUREMENT EQUIPMENT CONFIGURATION

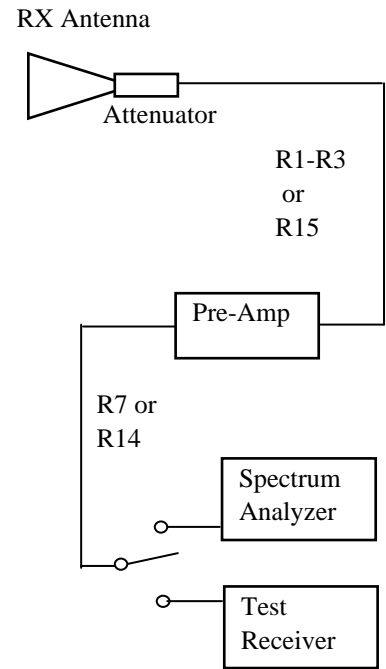
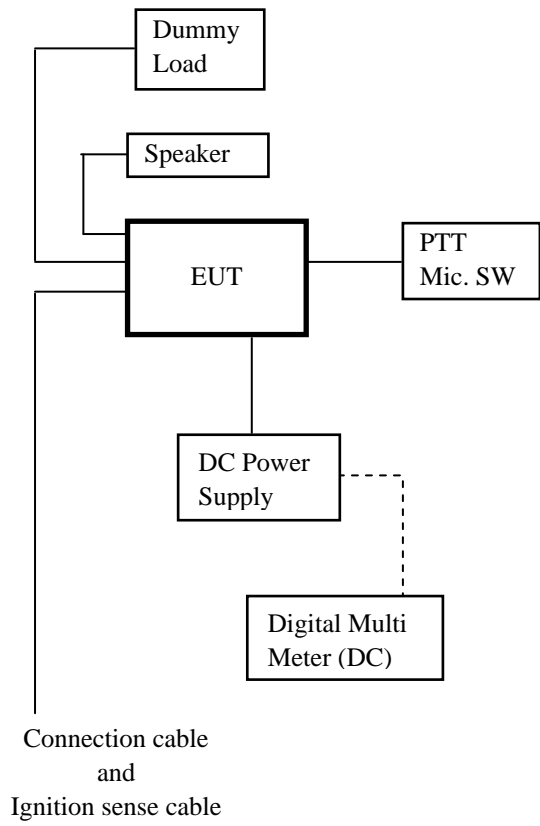



**TEST RESULTS**

Test date	Jul 31, 2009 to Aug 3, 2009
Location	Kashima No.1 Test Site
temperature	21.9 to 23.4 [degree C]
Humidity Variation	70 to 73 [%]
Atmospheric Pressure	100.6 to 100.9 [kPa]
Test Engineer	Koichi Wagatsuma

Test carried out for the RSS frequency band of section 10.1

Measured for the worst case

State : 173.95 MHz Receiver Condition

No.	Frequency (MHz)	Pol	Mode	Reading Level (dBuv)	Factor* (dB)	Emission Level (dBuV/m)	Limit Level (dBuV/m)	Margin (dB)
1	38.41	Hor.		-	-3.20	-	40.0	-
		Ver.		25.80	-3.20	22.60	40.0	17.4
2	73.72	Hor.		-	-4.90	-	40.0	-
		Ver.		23.80	-4.90	18.90	40.0	21.1
3	147.47	Hor.		-	-2.40	-	43.5	-
		Ver.		20.60	-2.40	18.20	43.5	25.3
4	196.62	Hor.		-	-4.40	-	43.5	-
		Ver.		18.00	-4.40	13.60	43.5	29.9
5	212.80	Hor.		18.00	-4.20	13.80	43.5	29.7
		Ver.		17.90	-4.20	13.70	43.5	29.8
6	425.60	Hor.		37.10	3.30	40.40	46.0	5.6
		Ver.		29.40	3.30	32.70	46.0	13.3
7	638.40	Hor.		24.80	8.80	33.60	46.0	12.4
		Ver.		23.00	8.80	31.80	46.0	14.2
8	851.20	Hor.		15.40	12.50	27.90	46.0	18.1
		Ver.		19.40	12.50	31.90	46.0	14.1
9	1064.00	Hor.	AVG	37.80	2.00	39.80	54.0	14.2
		Ver.	AVG	35.50	2.00	37.50	54.0	16.5
10	1702.40	Hor.	AVG	29.80	4.30	34.10	54.0	19.9
		Ver.	AVG	28.90	4.30	33.20	54.0	20.8

There is the margin of 20dB over except for the above points.

\* Factor = Antenna, Antenna Pad, Cable, Preamp

Emission Level = Reading Level + Factor

Note:

- 1 Measurement distance is 3 metres.
- 2 Scanned frequency are 30 to 2000 MHz.
- 3 Maximum local oscillator frequency is 212.8 MHz.

**10.11 Necessary Bandwidth and Emission Bandwidth**

REGULATIONS	: 47 CFR 2.202 (g) & Federal Register/ Vol.68, No236
	TRC 43

**Calculation Results**

State : 16K0F3E (Authorized Bandwidth 20 kHz)

Item	Mark		
Maximum Modulation	(M)	3	kHz
Maximum Deviation	(D)	5	kHz
Constant Factor	(K)	1	
Necessary Bandwidth	(Bn)	16	kHz

$$Bn = (2 \times M) + (2 \times D \times K)$$

State : 11K0F3E (Authorized Bandwidth 11.25 kHz)

Item	Mark		
Maximum Modulation	(M)	3	kHz
Maximum Deviation	(D)	2.5	kHz
Constant Factor	(K)	1	
Necessary Bandwidth	(Bn)	11	kHz

$$Bn = (2 \times M) + (2 \times D \times K)$$