



TEST REPORT

REGULATION :

FCC Part 2, 22, 74, 90, 90.210

Applicant	Testing Laboratory
Kenwood Corporation 1-16-2, Hakusan, Midori-ku, Yokohama-shi Kanagawa, 226-8525 Japan Tel.: +81 45 939 6254 Fax.: +81 45 939 7093	ETL SEMKO Japan K. K. Kashima No.1 Test site FCC File Number : 934283 3-2, Sunayama, Kamisu-shi, Ibaraki-ken 314-0255 Japan Tel.: +81 479 40 1097 Fax.: +81 479 46 1788 URL: www.japan.intertek-etlsemko.com

Equipment type	UHF P25 TRANSCEIVER
Trademark	KENWOOD
Model(s)	TK-5810H-K2
Serial No.	None
FCC ID	K4439923220
Measurement Method	ANSI/TIA-603-C-2004
Deviation from standard(s)	No deviation
Test Result	Complied
Report Number	ESJ-107061A
Report issue date	May 09, 2007

This equipment has been shown to be capable of compliance with the applicable standard(s) as indicated in the test report.

I attest to the accuracy of data. All measurements reported herein were performed by me or were made under my supervision and are correct to the best of my knowledge and belief. I assume full responsibility for the completeness of these measurements and vouch for the qualifications of all persons taking them.

This test report shall not be reproduced partially, or in full, without the prior written approval of ETL SEMKO Japan K. K. The results and statements contained in this report pertain only to the equipment evaluated.

Approved by

Kazuo Gokita

[Assistant Manager]

Tested by

Naoki Ikeda

TABLE OF CONTENTS

	Page
SECTION 1. GENERAL INFORMATION	3
SECTION 2. TEST AND MEASUREMENT DATA	5
SECTION 3. INFORMATION ABOUT EUT	6
SECTION 4. MEASUREMENT RESULT	8
SECTION 5. TEST DATA	
5.1 Carrier Output Power (Conducted)	9
5.2 Unwanted Emissions (Transmitter Conducted)	11
5.3 Field Strength of Spurious Radiation	14
5.4 Emission Masks (Occupied Bandwidth)	18
5.5 Transient Frequency Behavior	26
5.6 Audio Frequency Response / Audio Low Pass Filter (Voice Input)	30
5.7 Modulation Limiting	33
5.8 Frequency Stability (Temperature Variation)	37
5.9 Frequency Stability (Voltage Variation)	40
5.10 Necessary Bandwidth and Emission Bandwidth	42
SECTION 6. VALIDITY OF TEST REPORT	44
SECTION 7. DESCRIPTION OF TEST SITE	44
APPENDIX PHOTOGRAPHS	

SECTION 1. GENERAL INFORMATION

Description of Test Item	
Kind of EUT	: UHF P25 TRANSCEIVER
Condition of EUT	: Prototype
Type	: Mobile type
Trademark	: KENWOOD

Test Performed	
EUT Received	: March 09, 2007
Test started	: March 16, 2007
Test completed	: April 18, 2007
Temperature	: 20 to 28 degree C
Humidity	: 45 to 66 %
Atmospheric	: 100.8 to 102.8 kPa
Voltage	: DC 13.4 V
Current	: 28A Maximum
Frequency	: None

Test Tracability
Tracability to national standards of test result is achieved by means of calibration tractability to national or international standards.

Abbreviations	
EUT = Equipment Under Test	Cal Exp. = Calibration Expire
D.R.G. Antenna = Double Rigid Guide Antenna	ACC = External accessory connector

In Accordance with FCC Rules and Regulations, Volume II, Part 2 and 90

Sub-part 2.1033

(c)(1) Applicant and Manufacture Information	
APPLICANT	
Company	: Kenwood Corporation
Address	: 1-16-2, Hakusan, Midori-ku, Yokohama-shi Kanagawa, 226-8525 Japan
Contact Person	: Tamaki Shimamura Manager, Communications Equipment Division
MANUFACTURER	
Company	: Kenwood Corporation
Address	: 1-16-2, Hakusan, Midori-ku, Yokohama-shi, Kanagawa, 226-8525 Japan
(c)(2) FCC ID	
FCC ID	: K4439923220
Model number	: TK-5810H-K2
Serial number	: None
(c)(3) Instruction Manual(S)	
Instruction manual(s)	: Please refer to attached Exhibits F
(c)(4) Type of Emission	
Emission Designation	: 16K0F3E(Wide) / 11K0F3E(Narrow) 20K0F7D(Wide) / 11K2F7D(Narrow) 14K4F1D(Wide) / 7K20F1D(Narrow) 8K10F1E(Narrow) / 8K10F1D(Narrow)
(c)(5) Frequency range	
Frequency Range	: 406.1 to 470 MHz
(c)(6) Power Rating	
Output Power	: 50 to 100W
Type	: Continuously Variable
(c)(7) Maximum Power Rating	
Output Power	: 100 W
Other Information	
Number of Channel	: 512
Channel Spacing	: 25 kHz / 12.5 kHz
Maximum Deviation	: 5 kHz / 2.5 kHz
Frequency Stability	: 2.0 ppm (Specification)
Antenna Impedance	: 50 Ω Norminal

Note

SECTION 2. TEST AND MEASUREMENT DATA

All test and measurements indicated in this document were performed in accordance with the Code of Federal Regulations Title 47 Part 2, Sub-part J and Industry Canada as the following individual parts:

FCC Rule	Test Item	Tested
Part 21	Domestic Public Fixed radio Services	N.A.
Part 22	Non Cellular	YES
Part 22	Public Mobile Services	N.A.
Part 22	Subpart H - Cellular Radiotelephone Service	N.A.
Part 22	Alternative technologies and auxiliary service	N.A.
Part 23	International Fixed Public Radiocommunication service	N.A.
Part 24	Personal Communications Services	N.A.
Part 74	Subpart H - Low Power Auxiliary Stations	YES
Part 80	Stations in the Maritime Services	N.A.
Part 80	Subpart E - general Technical Standards	N.A.
Part 80	Subpart F - Equipment Authorization for Compulsory Ships	N.A.
Part 80	Subpart K - Private Coast Stations and Marine Utility Stations	N.A.
Part 80	Subpart S - Compulsory radiotelephone Installations for Small Passenger Boats	N.A.
Part 80	Subpart T - Radiotelephone Installation Required for Vessels on the Great Lakes	N.A.
Part 80	Subpart U - Radiotelephone Installations Required by the Bridge-to-Bridge Act	N.A.
Part 80	Subpart V - Emergency Position Indicating Radiobeacons (EPIRB'S)	N.A.
Part 80	Subpart W - Global Maritime Distress and Safety System (GMDSS)	N.A.
Part 80	Subpart X - Voluntary Radio Installations	N.A.
Part 87	Aviation Services	N.A.
Part 90	Private Land Mobile radio Services	YES
Part 94	Private Operational - Fixed Microwave Service	N.A.
Part 95	Subpart A - General Mobile radio Service	N.A.
Part 95	Subpart C - Radio Control (R/C) radio Service	N.A.
Part 95	Subpart D - Citizens Band (CB) Radio Service	N.A.
Part 95	Subpart E -Family radio Service	N.A.
Part 95	Subpart F -Interactive Video and Data Service (IVDS)	N.A.
Part 97	Amateur Radio Service	N.A.
Part 101	Fixed Microwave Service	N.A.

IC Rule	Test Item	Tested
RSS-119	Land Mobile and Fixed Radio Transmitters and Receivers	N.A.
RSS-Gen	General Requirements and Information for the Certification of Radiocommunication Equipment	N.A.

SECTION 3. INFORMATION ABOUT EUT

List of System Configuration

Symbol	Item	Model No.	Serial No.	Manufacture	Notes
A1	UHF P25 TRANSCEIVER	TK-5810H-K2	None	Kenwood Corporation	EUT
A2	Front Panel Kit	KCH-15	None	Kenwood Corporation	Option
A3	Control Head Remote Kit	KRK-5	None	Kenwood Corporation	Option
A4	External Speaker	KES-5	None	Kenwood Corporation	Option
A5	Keypad Microphone	KMC-28	None	Kenwood Corporation	Option
A6	Remote Control Cable	KCT22	None	Kenwood Corporation	Option
A7	Ignition Sense Cable	KCT18	None	Kenwood Corporation	Option

Port(s)/Connector(s)

Port Name	Connector Type	Connector Pin	Notes
Antenna	M	2 pin	
ACC	D-sub	25 pin	
ACC	None	9 pin	
Microphone	Kenwood Original	12 pin	

Used Cable(s)

No.	Name	Length (m)	Shield	Notes
1	Remote Control Cable	7.20	Plastic	
2	Speaker Cable	2.80	Plastic	
3	Mic. Cable	0.60	Plastic	
4	Cable	0.20	Plastic	
5	Power Cable for A1 (DC)	0.27		
6	Power External Cable for A1 (DC)	3.00		
7	Ignition Sense Cable	3.30	Plastic	

Details of Configuration and Connection

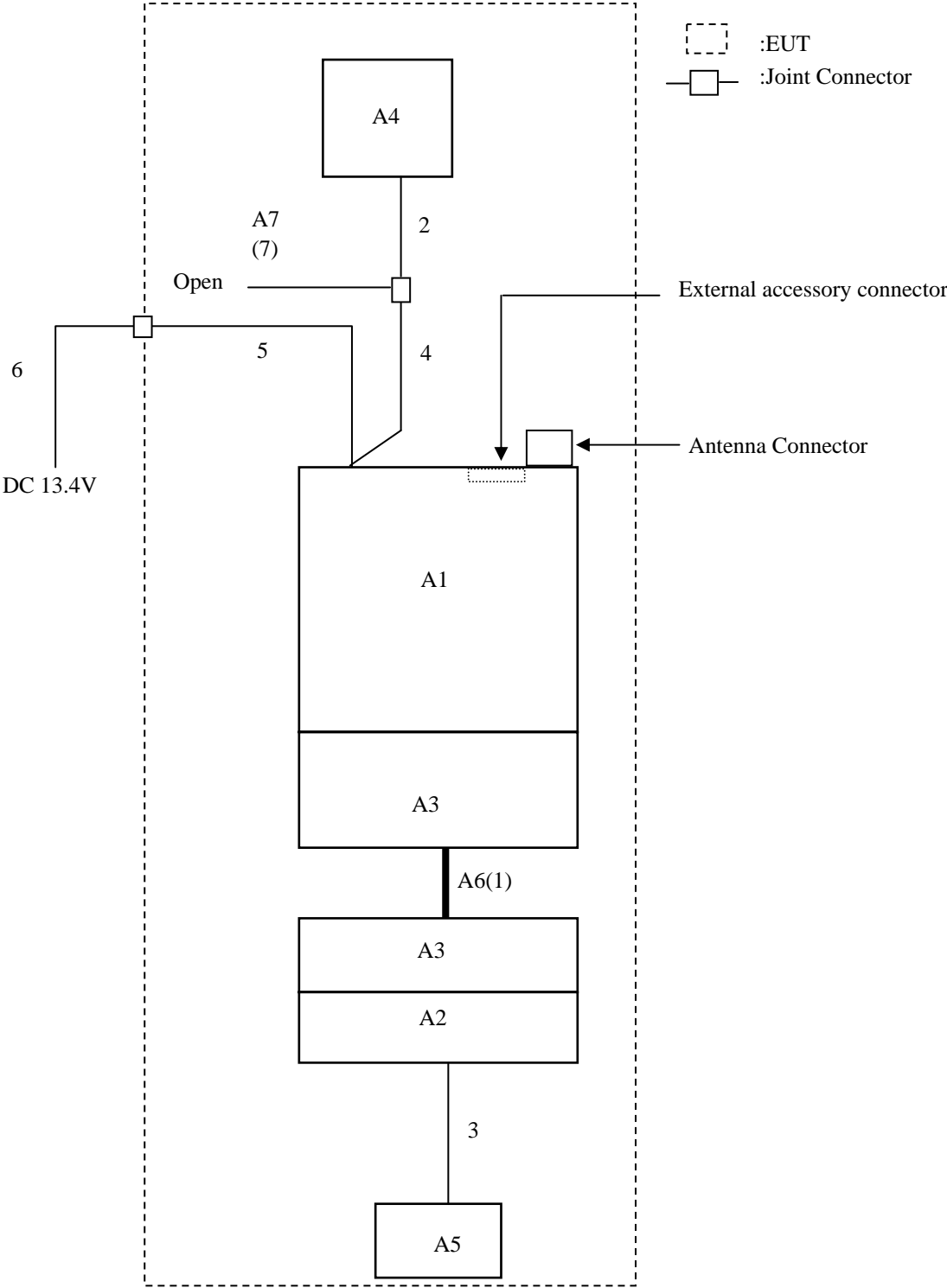

SECTION 4. MEASUREMENT RESULT

FCC Part2	Part22	Part74	Part90	TEST ITEM	RESULTS
2.1046 (a)	-	-	-	Carrier Output Power (Conducted)	PASS
2.1051	-	-	90.210	Unwanted Emissions (Transmitter Conducted)	PASS
2.1053 (a)	-	-	90.210	Field Strength of Spurious Radiation	PASS
2.1049 (c) (1)	22.359, 357 (a) (1)	74.1236	90.210	Emission Masks (Occupied Bandwidth)	PASS
-	-	-	90.214	Transient Frequency Behavior	PASS
2.1047 (a)	-	-	90.242 (b) (8)	Audio Low Pass Filter (Voice Input)	PASS
2.1047 (a)	-	-	-	Audio Frequency Response	PASS
2.1047 (b)	-	-	-	Modulation Limiting	PASS
2.1055 (a) (1)	22.355	74.1261 (b)	90.213 (a)	Frequency Stability (Temperature Variation)	PASS
2.1055 (d) (1)	22.355	74.1261 (b)	90.213 (a)	Frequency Stability (Voltage Variation)	PASS

Limitation on Results

The test result of this report is effective equipment under test itself and under the test configuration described on the report.

This test report dose not assure that whether the test result taken in other testing laboratory is compatible or reproducible to the test result on this report or not.

SECTION 5. TEST DATA

5.1 Carrier Output Power (Conducted)

REGULATIONS	: 47 CFR 2.1046 (a)
TEST METHOD/GUIDE	: ANSI/TIA-603-C Section 2.2.1.2

Test Procedure

- 1 The EUT and test equipment were set up as shown on the following page.
- 2 The EUT was conducted to a resistive coaxial attenuator of normal load impedance.
 $RF\ Power\ (dBm) = Power\ Meter\ reading\ (dBm) + Attenuator\ Loss\ (dB) + Cable\ Loss\ (dB)$
 $RF\ Power\ (W) = 10^{(RF\ Power\ (dBm)/10)}/1000$

Measuring Equipments

No.	Equipment	Manufacture	Model No.	Serial No.	Cal Date	Cal Exp.
1	Power Meter	Hewlett Packard	E4418B	GB38410404	Feb. 02, 07	Feb. 29, 08
2	Power Sensor	Hewlett Packard	8482A	US37292242	May. 26, 06	May. 31, 07
3	Attenuator (20dB)	Weinschel	40-20-34	AA5761	Jun. 15, 06	Jun. 30, 07
4	Attenuator (30dB)	Weinschel	WA-29-30-34	8923	Jun. 15, 06	Jun. 30, 07
5	DC Power Supply	Daiwa	PS-3020	None	None	None
6	Digital Multi Meter	Sanwa	CD721	3215593	May 15, 06	May 31, 07

Measuring Cables

No.	Cable	Manufacturer	Model No.	Serial No.	Cal Date	Cal Exp.
W1	Coaxial Cable	Suhner	SUCOFLEX102	KSR00046	Aug. 01, 06	Aug. 31, 07
W2	Coaxial Cable	Pacific custom	RG-58 C/U	AM90C02	Aug. 01, 06	Aug. 31, 07

Measuring Equipment Configuration

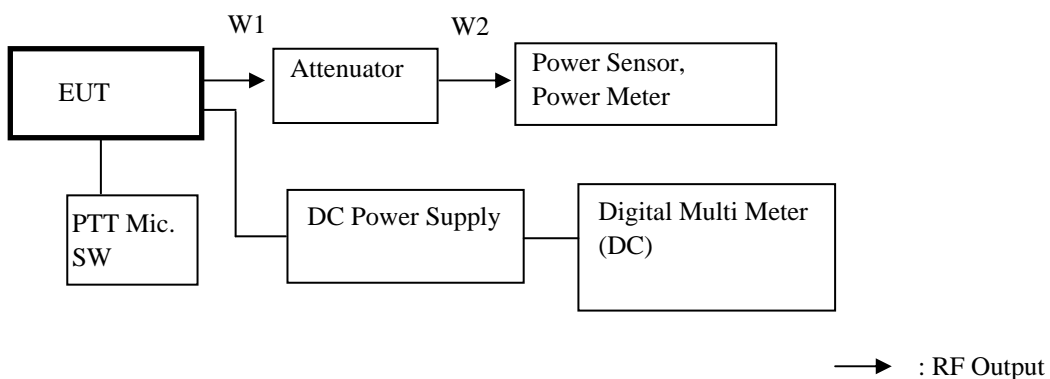

Uncertainty

Measurement uncertainty is +/- 0.5dB (k = 2)

Test Results

Measured for the worst case

No.	Frequency (MHz)	Band	Setting	RF Power (W)
1	406.15	Low	High Power	100
2	438.05	Middle	High Power	100
3	469.95	High	High Power	100
4	406.15	Low	Low Power	50
5	438.05	Middle	Low Power	50
6	469.95	High	Low Power	50

5.2 Unwanted Emissions (Transmitter Conducted)

REGULATIONS	: 47 CFR 2.1051, 90.210
TEST METHOD/GUIDE	: ANSI/TIA-603-C Section 2.2.13.2

Test Procedure

- 1 The EUT and test equipment were set up as shown on the following page.
- 2 Modulate the transmitter with a 2.5 kHz sine wave at an input Level of 16 dB greater than that necessary to produce 50 % of rated system deviation.
- 3 Adjust the spectrum analyzer for the following setting:
 - a) Resolution Bandwidth : 10 kHz (< 1 GHz), 1 MHz (> 1 GHz).
 - b) Video Bandwidth : 30 kHz (< 1 GHz), 3 MHz (> 1 GHz).
 - c) Sweep Speed : 50 msec.
 - d) Detector mode : Average
- 4 The emissions were measured for the worst case as follows:
 - a) : within a band of frequencies defined by the carrier frequency plus and minus one channel.
 - b) : from the lowest frequency generated in the EUT and to at least the 10th harmonic of the carrier frequency, or 40 GHz, whichever is lower.

Measuring Equipments

No.	Equipment	Manufacture	Model No.	Serial No.	Cal Date	Cal Exp.
1	Audio Generator	Anritsu	MG443B	M70150	Aug. 15, 06	Aug. 31, 07
2	Attenuator (20dB)	Weinschel	40-20-34	AA5761	Jun. 15, 06	Jun. 30, 07
3	Attenuator (30dB)	Weinschel	WA-29-30-34	8923	Jun. 15, 06	Jun. 30, 07
4	Modulation Analyzer	Hewlett Packard	8901B	3403A04852	Apr. 12, 06	Apr. 30, 07
5	Spectrum Analyzer	Agilent	E4407B	MY45102460	Oct. 03, 06	Oct. 31, 07
6	Signal Generator	Rohde&Schwarz	SMT06	100684	Oct. 24, 06	Oct. 31, 07
7	Highpass Filter	Anritsu	MP526D	6200220657	Aug. 01, 06	Aug. 31, 07
8	DC Power Supply	Daiwa	PS-3020	None	None	None
9	Digital Multi Meter	Sanwa	CD721	3215593	May 15, 06	May. 31, 07

Measuring Cables

No.	Cable	Manufacturer	Model No.	Serial No.	Cal Date	Cal Exp.
W2	Coaxial Cable	Pacific custom	RG-58 C/U	AM90C02	Aug. 01, 06	Aug. 31, 07
W3	Coaxial Cable	Suhner	SUCOFLEX100	KSR00091	Oct. 01, 06	Oct. 31, 07
W4	Coaxial Cable	Pacific custom	RG-58 C/U	AM90C03	Aug. 01, 06	Aug. 31, 07
W5	Balance Cable	Nicoon	3D-2V	KSR00092	Oct. 01, 06	Oct. 31, 07

Measuring Equipment Configuration

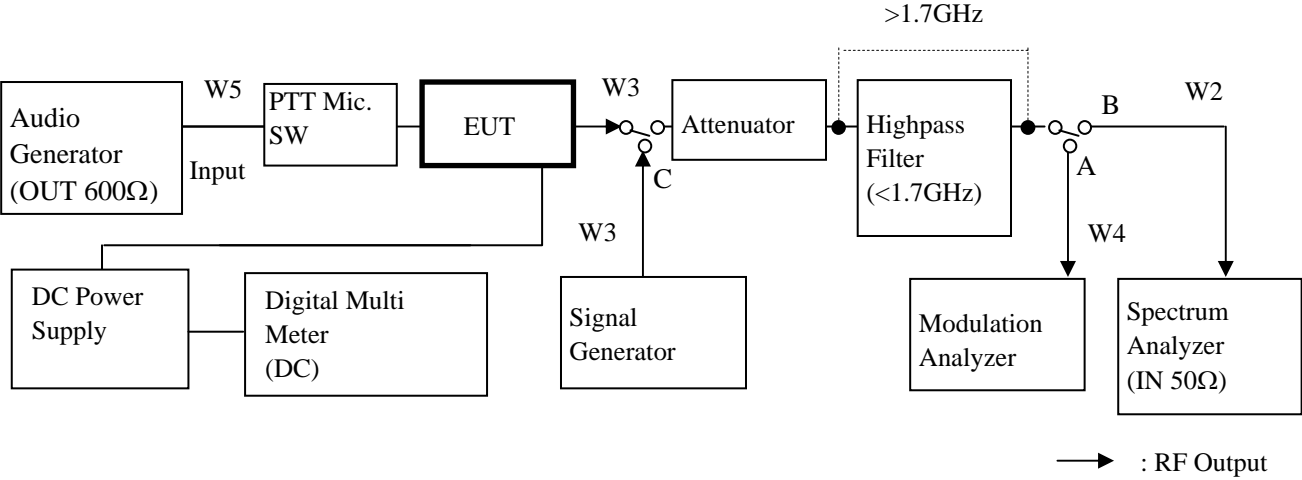

Uncertainty

Measurement uncertainty is +/- 1.5 dB (k = 2)

Test Results

Measured for the worst case

State : High Power / 12.5 kHz channel bandwidth

No.	Band	Frequency (MHz)	Correct Level (dBm)	Emission Level (dBc)	Limit (dBc)	Margin (dB)
1	Low	812.30	-35.82	-85.82	-70.0	15.8
2	Middle	1314.15	-35.18	-85.18	-70.0	15.2
3	High	1409.85	-38.67	-88.67	-70.0	18.7

There is the margin of 20dB over except for the above points.

State : Low Power / 12.5 kHz channel bandwidth

No.	Band	Frequency (MHz)	Correct Level (dBm)	Emission Level (dBc)	Limit (dBc)	Margin (dB)
1	Low	812.30	-34.34	-81.33	-67.0	14.3
2	Middle	876.10	-32.24	-79.23	-67.0	12.2
3	High	1409.85	-41.48	-88.47	-67.0	21.5

There is the margin of 20dB over except for the above points.

Mask D Limit (dBc) = $-(50+10\log(P))$

Correct Level (dBm) = Substitute SG Level (dBm)

Emission Level (dBc) = Correct Level (dBm) - $10\log(P*1000)$

P = Carrier Level (W)

" - " = Measurement Limit

5.3 Field Strength of Spurious Radiation

REGULATIONS	: 47 CFR 2.1053 (a), 90.210
TEST METHOD/GUIDE	: ANSI/TIA-603-C Section 2.2.12.2

Test Procedure

- 1 The EUT and test equipment were set up as shown on the following page.
- 2 Adjust the spectrum analyzer for the following setting:
 - a) Resolution Bandwidth : 10 kHz (< 1 GHz), 1 MHz (> 1 GHz).
 - b) Video Bandwidth : 300 kHz (< 1 GHz), 3 MHz (> 1 GHz).
 - c) Sweep Speed : 50ms.
 - d) Detector mode : Positive Peak
- 3 The transmitter was placed on a wooden turntable, and it was transmitting into non-radiating load which was also placed on the turntable.
- 4 The measurement antenna was placed at a distance of 3 meters from the EUT.
 During the tests, the antenna height and polarization as well as EUT azimuth were varied in order to identify the maximum level of emissions from the EUT.
 The test was performed by placing the EUT on 3-orthogonal axis.
- 5 The frequency range up to tenth harmonic of the fundamental frequency was investigated.
- 6 Remove the EUT and replace it with substitution antenna. A signal generator was connected to the substitution antenna by a non-radiating cable.
 The absolute levels of the spurious emissions were measured by the substitution.
- 7 Spurious emissions in dB = 10 Log (TX power in Watts/0.001) – the absolute level
- 8 Spurious attenuation Wide Band Modulaion limit in dB = 43 + 10 Log10 (power out in Watts)
- 9 Spurious attenuation Narrow Band Modulaion limit in dB = 50 + 10 Log10 (power out in Watts)

Measuring Equipments

No.	Equipment	Manufacture	Model No.	Serial No.	Cal Date	Cal Exp.
1	Dipole Antenna(TX)	Schwarzbeck	UHA9105	None	Apr. 26, 06	Apr. 30, 07
2	D.R.G Antenna(TX)	Schwarzbeck	3115	5045	Jun. 08, 06	Jun. 30, 07
3	Tri-log Antenna(RX)	Schwarzbeck	VULB9168	106	Aug. 29, 06	Aug. 31, 07
4	D.R.G Antenna(RX)	Schwarzbeck	3115	5044	Jun. 08, 06	Jun. 30, 07
5	Pre-Amplifier	Hewlett Packard	83051A	3332A00329	Sep. 27, 06	Sep. 30, 07
6	Step Attenuator	Hewlett Packard	8494B	2726A14513	Jan. 15, 07	Jan. 31, 08
7	Attenuator(6dB)	Anritsu	MP721B	M57593	Jan. 15, 07	Jan. 31, 08
8	Attenuator(3dB)	Narda	4768-3	79	Sep. 27, 06	Sep. 30, 07
9	Attenuator(10dB)	HUBER+SUHNER	6810.17B	KSR0044	Aug. 01, 06	Aug. 31, 07
10	Spectrum Analyzer	Advantest	R3182	111100429	Mar. 29, 07	Mar. 31, 08
11	Signal Generator	Rohde&Schwarz	SMT06	100684	Oct. 24, 06	Oct. 31, 07
12	Dummy Load	TME	CT-150NP	1138693	Aug. 01, 06	Aug. 31, 07
13	DC Power Supply	Daiwa	PS-3020	None	None	None
14	Digital Multi Meter	Sanwa	CD721	3215593	May 15, 06	May 31, 07

Measuring Cables

No.	Cable	Manufacturer	Model No.	Serial No.	Cal Date	Cal Exp.
W3	Coaxial Cable	Suhner	SUCOFLEX100	KSR00046	Aug. 01, 06	Aug. 31, 07
W6	Coaxial Cable	Suhner	SUCOFLEX102	KSR00091	Oct. 01, 06	Oct. 31, 07
W7	Coaxial Cable	Radiall	R286401332	KSR00048	Aug. 01, 06	Aug. 31, 07
R1	Coaxial Cable	ETL SEMKO	5D-2W	None	Jan. 15, 07	Jan. 31, 08
R2	Coaxial Cable	ETL SEMKO	10D-2W	None	Jan. 15, 07	Jan. 31, 08
R3	Coaxial Cable	ETL SEMKO	5D-2W	None	Jan. 15, 07	Jan. 31, 08
R7	Coaxial Cable	ETL SEMKO	5D-2W	None	Jan. 15, 07	Jan. 31, 08
R14	Coaxial Cable	Suhner	SUCOFLEX102	712/2	Sep. 27, 06	Sep. 30, 07
R15	Coaxial Cable	Insulated Wire	KSP-1501-1969- KPS	03292003	Sep. 27, 06	Sep. 30, 07

Measuring Equipment Configuration

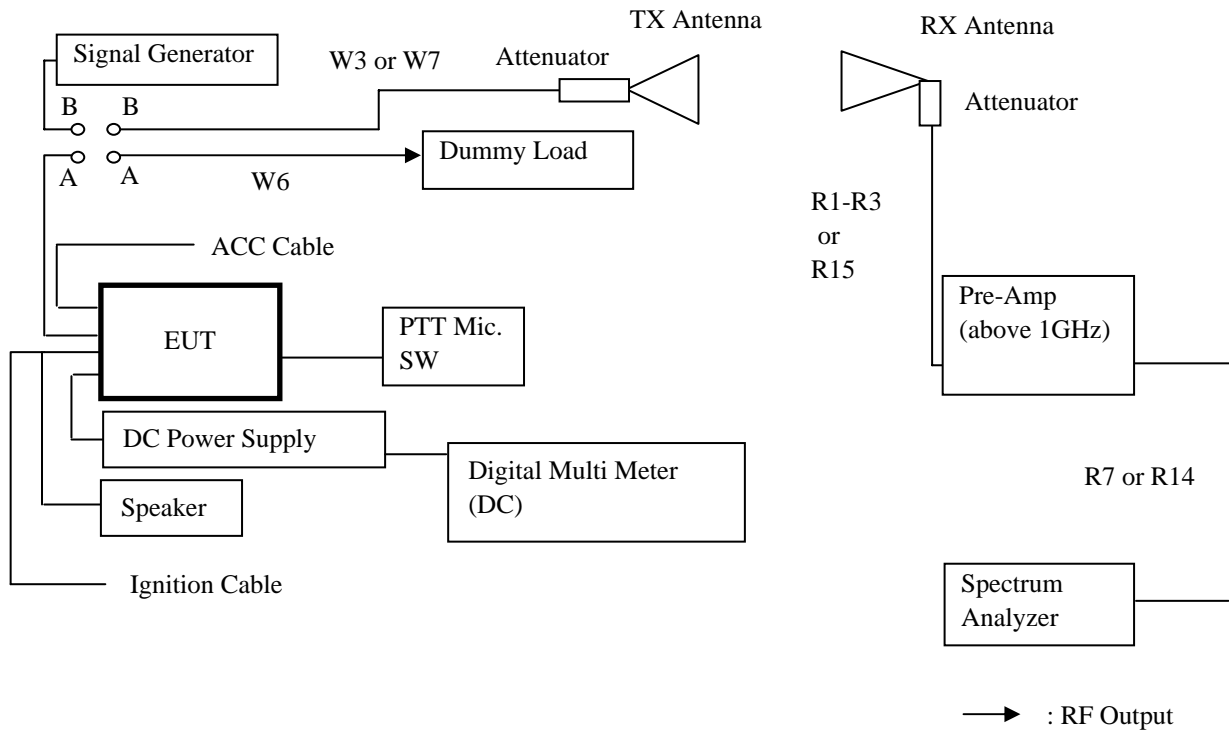

Uncertainty

Measurement uncertainty is +/- 4.8dB (k = 2)

Test Results

Measured for the worst case

State : High Power / 12.5 kHz channel bandwidth / 406.15 MHz

No	Frequency (MHz)	Pol	Reading Level (dBm)	SG Out Level (dBm)	Loss (dB)	Antenna Gain (dBi)	Correct Level (dBm)	Emission Level (dBc)	Limit Level (dBc)	Margin (dB)
1	812.30	Hor.	-75.00	-22.80	12.52	2.15	-33.2	-83.2	-70.0	13.2
		Ver.	-74.75	-22.00	12.52	2.15	-32.4	-82.4	-70.0	12.4
2	1218.45	Hor.	-54.40	-38.50	12.09	4.18	-46.4	-96.4	-70.0	26.4
		Ver.	-53.50	-36.00	12.09	4.18	-43.9	-93.9	-70.0	23.9
3	1624.60	Hor.	-51.20	-40.40	12.52	6.48	-46.4	-96.4	-70.0	26.4
		Ver.	-57.00	-45.40	12.52	6.48	-51.4	-101.4	-70.0	31.4
4	2030.75	Hor.	-30.50	-14.00	12.95	5.54	-21.4	-71.4	-70.0	1.4
		Ver.	-31.10	-15.40	12.95	5.54	-22.8	-72.8	-70.0	2.8
5	2436.90	Hor.	-56.00	-40.40	13.30	6.15	-47.5	-97.5	-70.0	27.5
		Ver.	-53.00	-35.40	13.30	6.15	-42.5	-92.5	-70.0	22.5
6	2843.05	Hor.	-53.40	-35.30	13.65	7.00	-41.9	-91.9	-70.0	21.9
		Ver.	-52.80	-31.10	13.65	7.00	-37.7	-87.7	-70.0	17.7
7	3249.20	Hor.	-53.44	-31.00	13.92	7.64	-37.3	-87.3	-70.0	17.3
		Ver.	-54.55	-29.30	13.92	7.64	-35.6	-85.6	-70.0	15.6
8	3655.35	Hor.	-60.00	-36.00	14.14	8.44	-41.7	-91.7	-70.0	21.7
		Ver.	-56.60	-30.30	14.14	8.44	-36.0	-86.0	-70.0	16.0
9	4061.50	Hor.	-57.10	-35.00	14.37	8.98	-40.4	-90.4	-70.0	20.4
		Ver.	-56.96	-27.10	14.37	8.98	-32.5	-82.5	-70.0	12.5

There is the margin of 20dB over except for the above points.

$$\text{Mask D Limit (dBc)} = -(50+10\text{Log}(P))$$

$$\text{Correct Level (dBm)} = \text{Substitute SG Level (dBm)} + \text{ANT Gain (dBi)} - \text{Loss (Cable, Attenuator) (dB)}$$

$$\text{Emission Level (dBc)} = \text{Correct Level (dBm)} - 10\text{Log}(P*1000)$$

$$P = \text{Carrier Level (W)}$$

" - " = Measurement Limit

State : Low Power / 12.5 kHz channel bandwidth / 438.05 MHz

No	Frequency (MHz)	Pol	Reading Level (dBm)	SG Out Level (dBm)	Loss (dB)	Antenna Gain (dBi)	Correct Level (dBm)	Emission Level (dBc)	Limit Level (dBc)	Margin (dB)
1	876.10	Hor.	-83.50	-31.00	12.52	2.15	-41.4	-88.4	-67.0	21.4
		Ver.	-71.60	-16.60	12.52	2.15	-27.0	-74.0	-67.0	7.0
2	1314.15	Hor.	-50.60	-38.50	12.09	4.18	-46.4	-93.4	-67.0	26.4
		Ver.	-50.14	-34.70	12.09	4.18	-42.6	-89.6	-67.0	22.6
3	1752.20	Hor.	-50.50	-36.80	12.52	6.48	-42.8	-89.8	-67.0	22.8
		Ver.	-47.00	-33.20	12.52	6.48	-39.2	-86.2	-67.0	19.2
4	2190.25	Hor.	-52.40	-38.00	12.95	5.54	-45.4	-92.4	-67.0	25.4
		Ver.	-56.70	-43.40	12.95	5.54	-50.8	-97.8	-67.0	30.8
5	2628.30	Hor.	-54.80	-36.60	13.30	6.15	-43.7	-90.7	-67.0	23.7
		Ver.	-59.30	-41.80	13.30	6.15	-48.9	-95.9	-67.0	28.9
6	3066.35	Hor.	-55.00	-35.30	13.65	7.00	-41.9	-88.9	-67.0	21.9
		Ver.	-54.72	-33.40	13.65	7.00	-40.0	-87.0	-67.0	20.0
7	3504.40	Hor.	-57.81	-37.40	13.92	7.64	-43.7	-90.7	-67.0	23.7
		Ver.	-61.00	-36.30	13.92	7.64	-42.6	-89.6	-67.0	22.6
8	3942.45	Hor.	-58.60	-36.40	14.14	8.44	-42.1	-89.1	-67.0	22.1
		Ver.	-60.60	-31.00	14.14	8.44	-36.7	-83.7	-67.0	16.7
9	4380.50	Hor.	-	-	14.37	8.98	-	-	-	-
		Ver.	-62.00	-34.70	14.37	8.98	-40.1	-87.1	-67.0	20.1

There is the margin of 20dB over except for the above points.

Mask D Limit (dBc) = $-(50+10\log(P))$

Correct Level (dBm) = Substitute SG Level (dBm) + ANT Gain (dBi) - Loss (Cable, Attenuator) (dB)

Emission Level (dBc) = Correct Level (dBm) - $10\log(P*1000)$

P = Carrier Level (W)

" - " = Measurement Limit

5.4 Emission Masks (Occupied Bandwidth)

REGULATIONS	: 47 CFR 2.1049 (c) (1), 22.359, 357 (a) (1) , 74.1236 , 90.210
TEST METHOD/GUIDE	: ANSI/TIA-603-C Section 2.2.11.2

Test Procedure

- 1 The EUT and test equipment were set up as shown on the following page.
- 2 For EUT supporting audio modulation, the audio signal generator was adjusted to the frequency of maximum response and with output level set for +/- 2.5 kHz or +/- 1.25 kHz deviation (or 50 % modulation).
- 3 With level constant, the signal level was increased 16 dB.
 For EUT supporting digital modulation, the digital modulation mode was operated to its maximum extent.
- 4 Adjust the spectrum analyzer for the following setting:
 - a) Resolution Bandwidth : 100 Hz (Nonmodulation and Narrow modulation), 300 Hz (Wide modulation).
 - b) Video Bandwidth : 30 kHz (Nonmodulation), 100 Hz (Narrow band modulation), 3kHz (Wide band modulation).
 - c) Sweep Speed : 8 sec.
 - d) Sampling Time : 10 times
- 5 The occupied Bandwidth was measured with the Spectrum Analyzer controls set as shown on the test results.

Measuring Equipments

No.	Equipment	Manufacture	Model No.	Serial No.	Cal Date	Cal Exp.
1	Audio Generator	Anritsu	MG443B	1004468	Aug. 15, 06	Aug. 31, 07
2	Attenuator (20dB)	Weinschel	40-20-34	AA5761	Jun. 15, 06	Jun. 30, 07
3	Attenuator (30dB)	Weinschel	WA-29-30-34	8923	Jun. 15, 06	Jun. 30, 07
4	Attenuator (10dB)	TME	CFA-05NPJ-10	262843	Aug. 01, 06	Aug. 31, 07
5	Modulation Analyzer	HP	8901B	3403A04852	Apr. 12, 06	Apr. 30, 07
6	Spectrum Analyzer	Agilent	E4407B	MY45102460	Oct. 03, 06	Oct. 31, 07
7	Modem Evaluation Kit	Consumer Microcircuits	EV9000	None	None	None
8	DC Power Supply(1)	Daiwa	PS-3020	None	None	None
9	DC Power Supply(2)	Kenwood	PW18-1.8Q	None	None	None
10	Digital Multi Meter	Sanwa	CD721	3215593	May 15, 06	May 31, 07

Measuring Cables

No.	Cable	Manufacture	Model No.	Serial No.	Cal Date	Cal Exp.
W1	Coaxial Cable	Suhner	SUCOFLEX102	KSR00046	Aug. 01, 06	Aug. 31, 07
W2	Coaxial Cable	Pacific custom	RG-58 C/U	AM90C02	Aug. 01, 06	Aug. 31, 07
W4	Coaxial Cable	Pacific custom	RG-58 C/U	AM90C03	Aug. 01, 06	Aug. 01, 06
W5	Balance Cable	Nicoon	3D-2V	KSR00092	Oct. 01, 06	Aug. 02, 06
R14	Coaxial Cable	Suhner	SUCOFLEX102	712/2	Sep. 27, 05	Sep. 30, 06

Measuring Equipment Configuration

<FM Modulation Case>

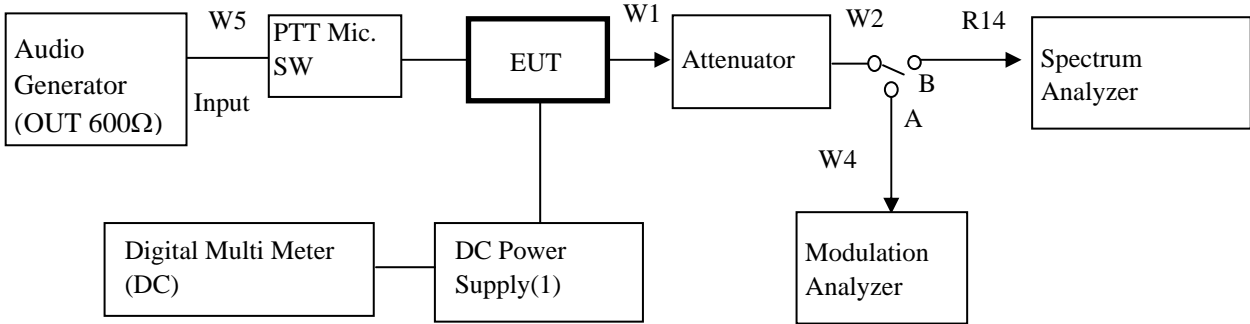

<GMSK and 4Level FSK Modulation Case>

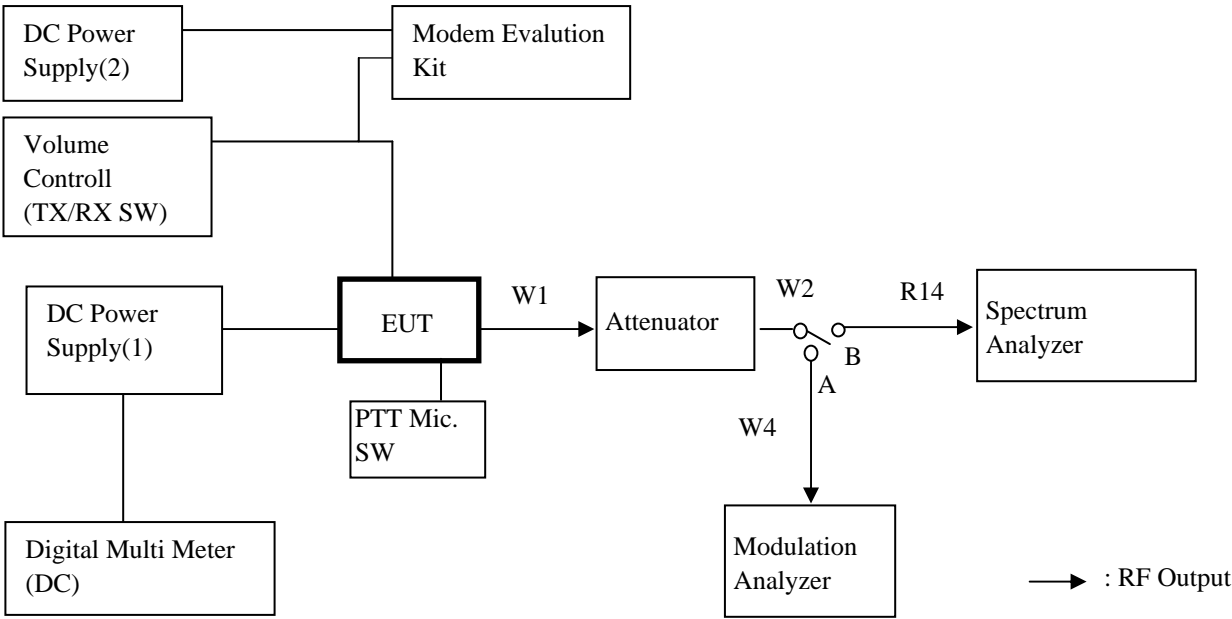

Uncertainty

Measurement uncertainty is +/- 1.0dB (k = 2)

Test Results

Measured for the worst case

State : High Power / 25 kHz channel bandwidth:FM / 438.05 MHz

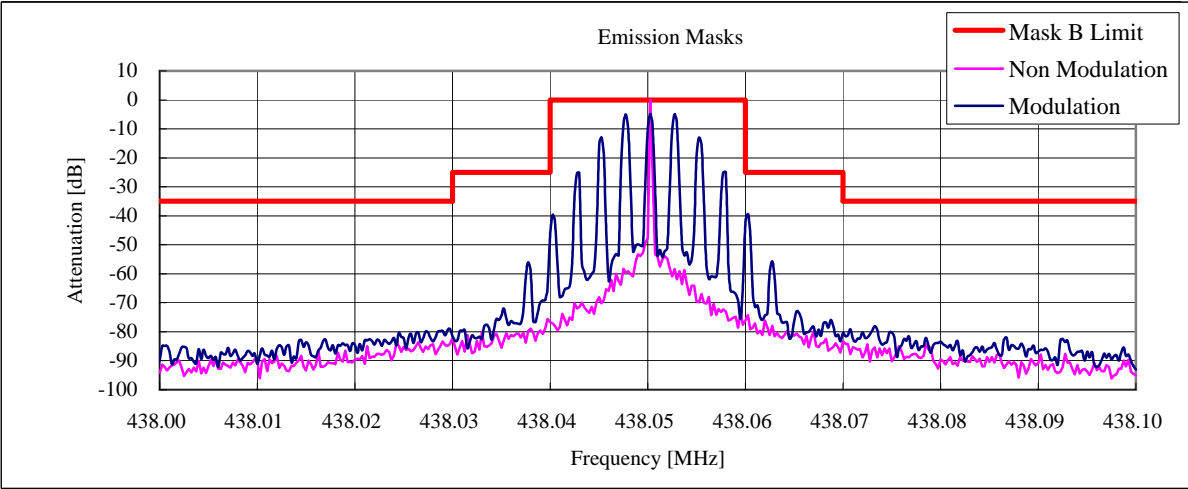

State : High Power / 12.5 kHz channel bandwidth:FM / 438.05 MHz

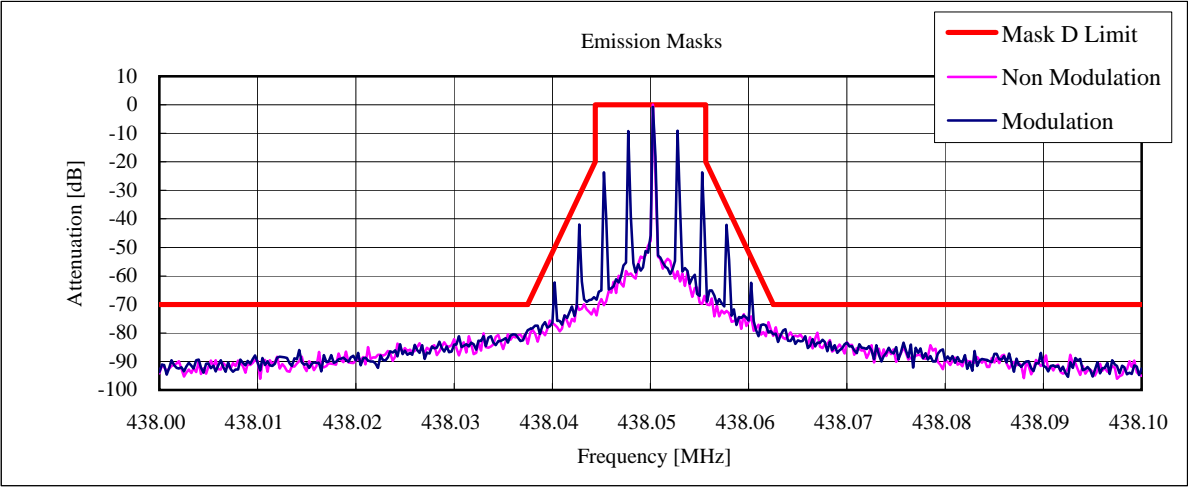

State : High Power / 25 kHz channel bandwidth:4 Level FSK / 438.05 MHz

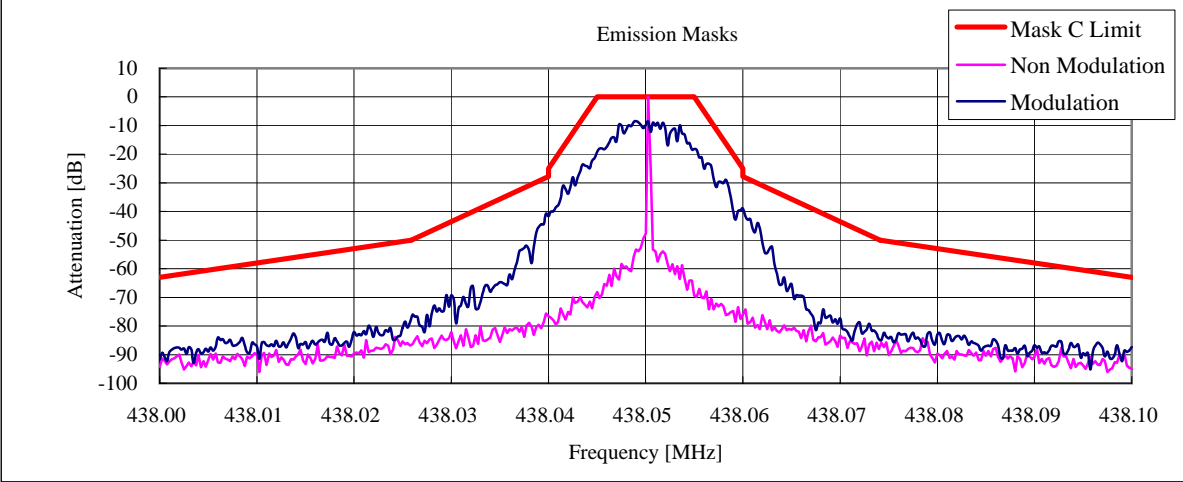

State : High Power / 12.5 kHz channel bandwidth:4Level FSK / 438.05 MHz

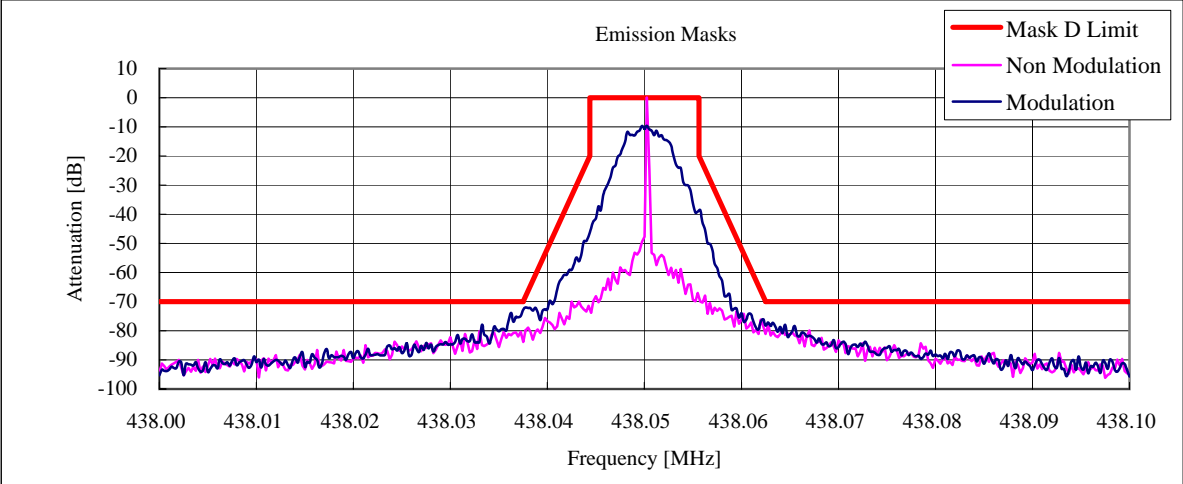

State : High Power / 25 kHz channel bandwidth:GMSK / 406.15 MHz

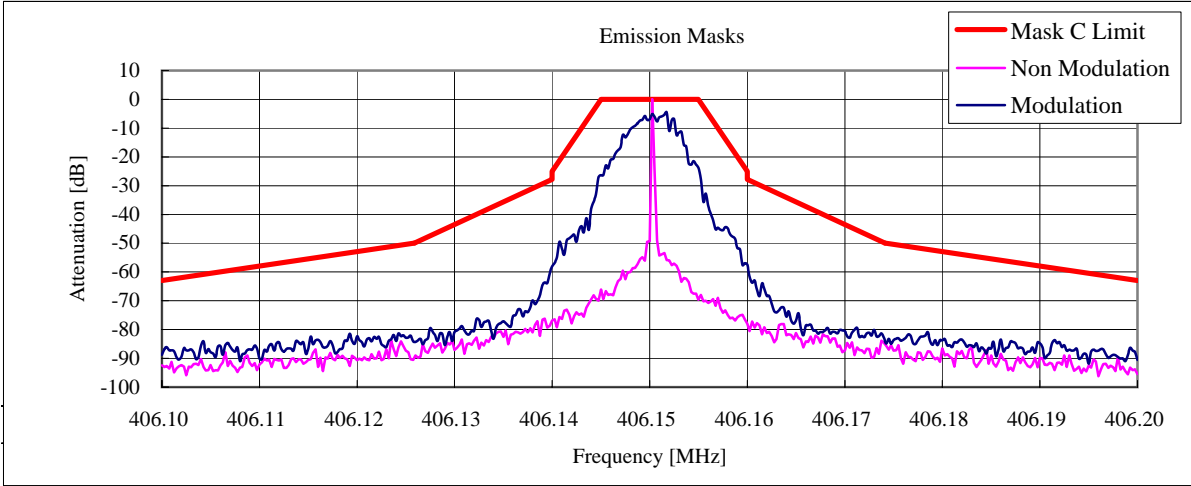

State : High Power / 12.5 kHz channel bandwidth:GMSK / 406.15 MHz

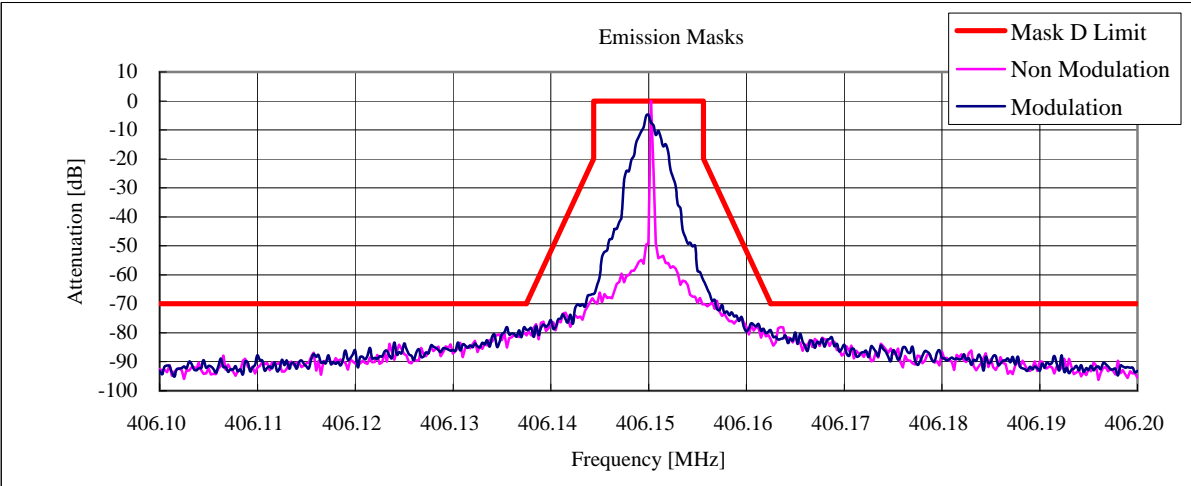

State : High Power / 12.5 kHz channel bandwidth:C4FM / 469.95 MHz

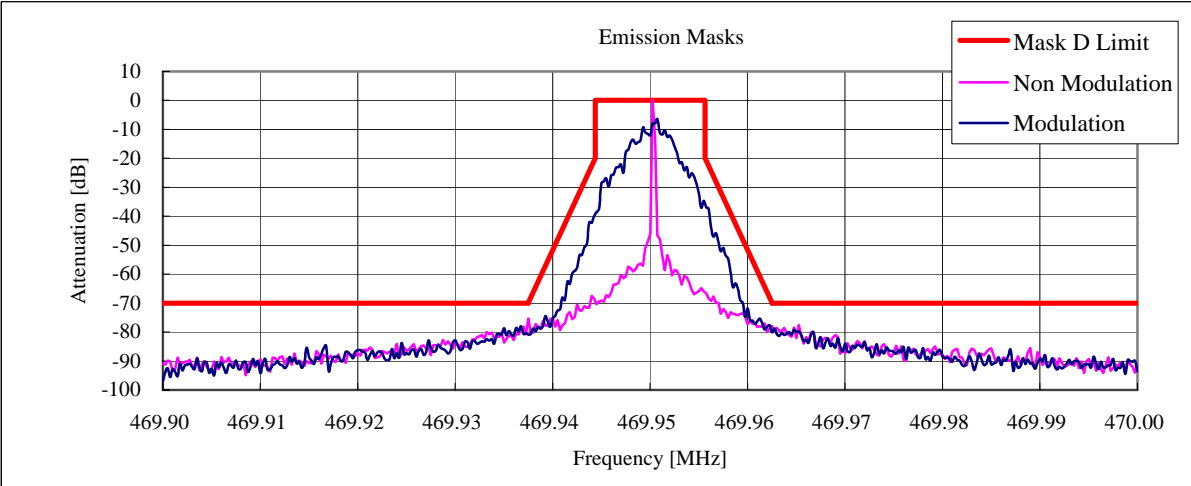

State : Low Power / 25 kHz channel bandwidth:FM / 438.05 MHz

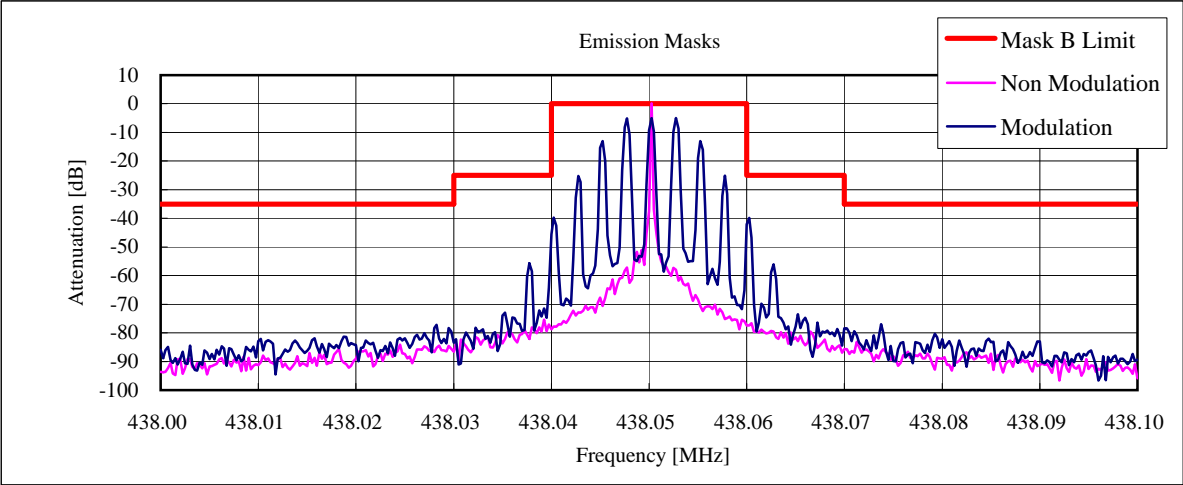

State : Low Power / 12.5 kHz channel bandwidth:FM / 438.05 MHz

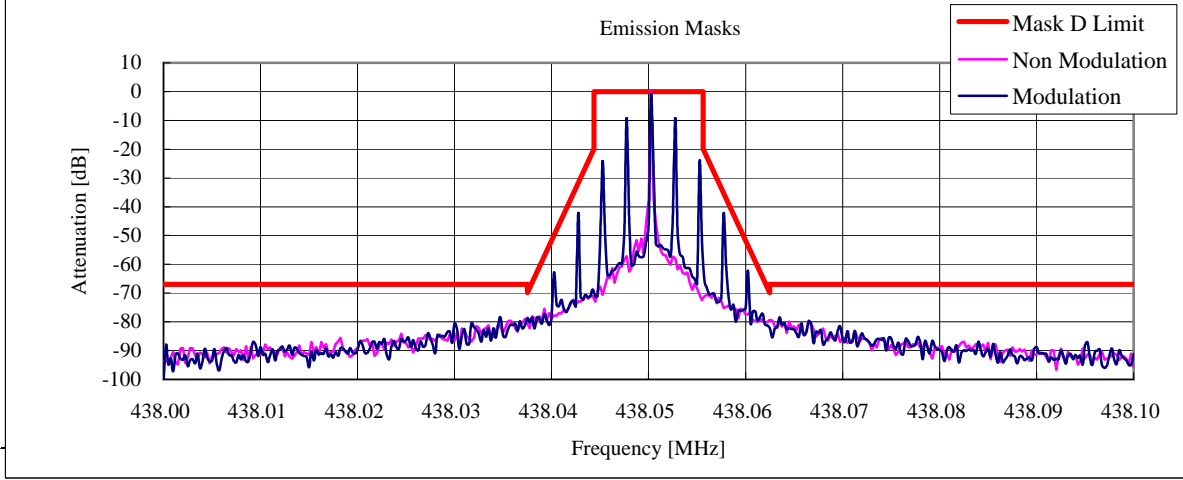

State : Low Power / 25 kHz channel bandwidth:4 Level FSK / 438.05 MHz

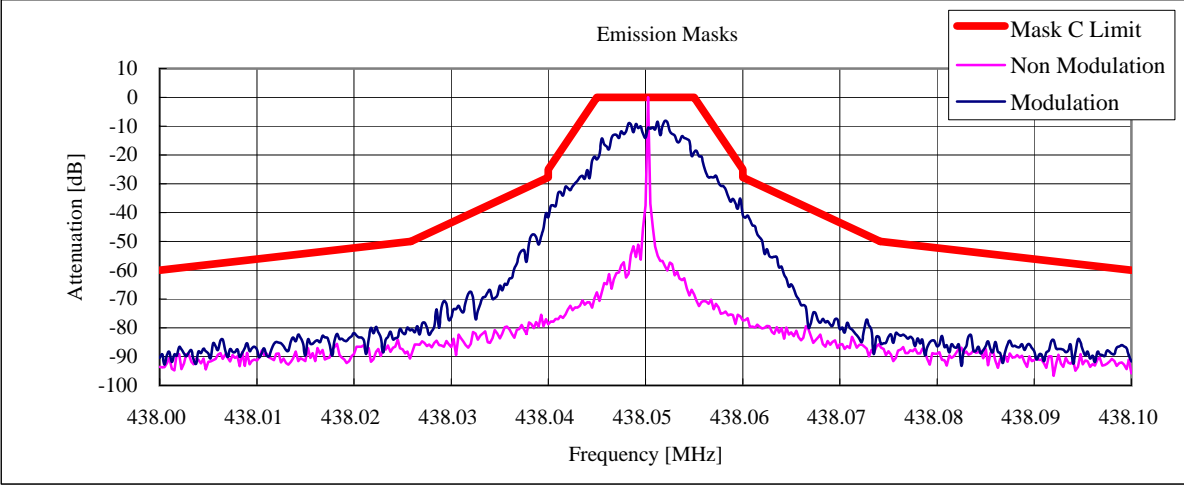

State : Low Power / 12.5 kHz channel bandwidth:4Level FSK / 438.05 MHz

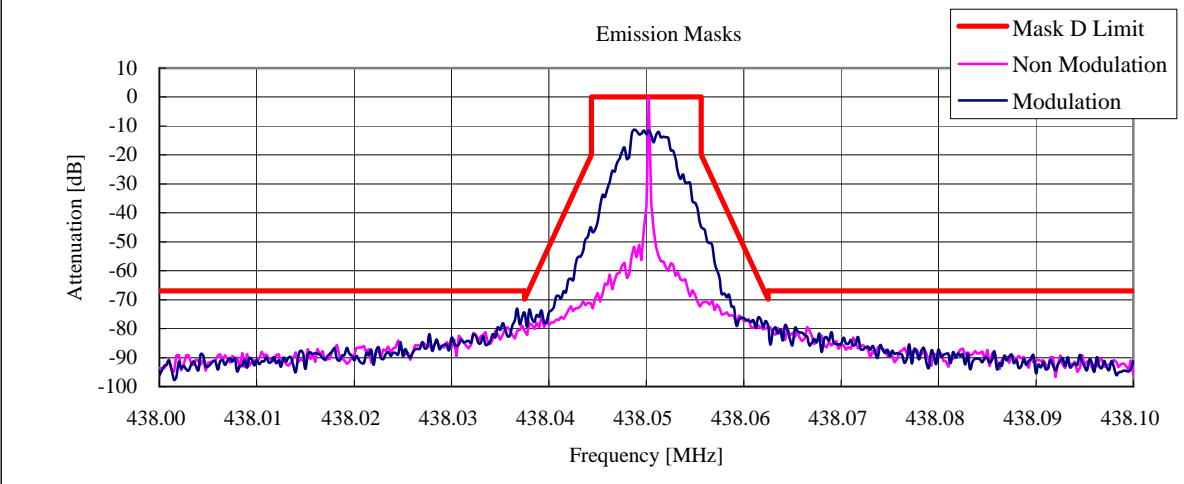

State : Low Power / 25 kHz channel bandwidth:GMSK / 406.15 MHz

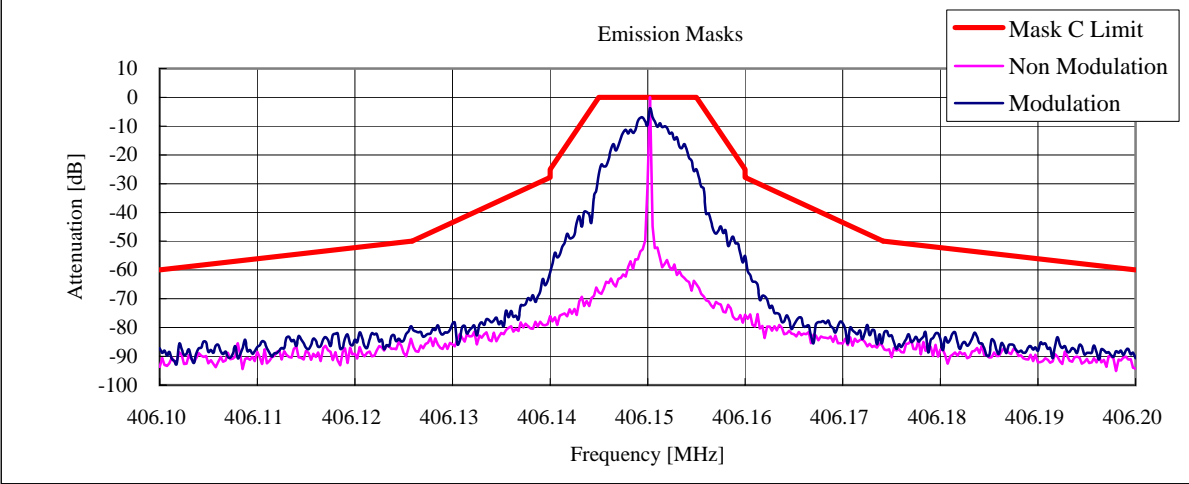

State : Low Power / 12.5 kHz channel bandwidth:GMSK / 406.15 MHz

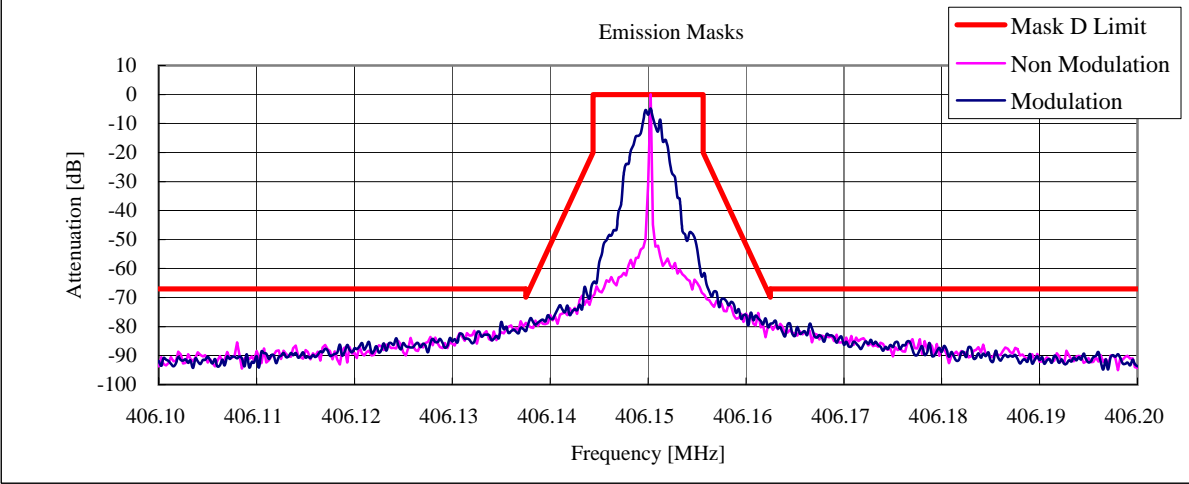

State : Low Power / 12.5 kHz channel bandwidth:C4FM / 469.95 MHz

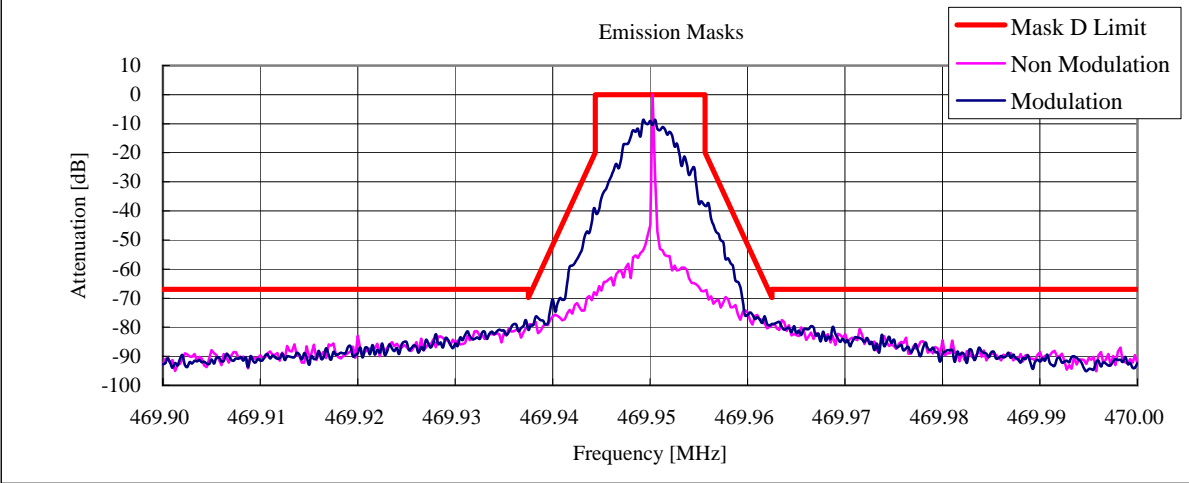

5.5 Transient Frequency Behavior

REGULATIONS	: 47 CFR 90.214
TEST METHOD/GUIDE	: ANSI/TIA-603-C, Section 2.2.19.3

Test Procedure

- 1 The EUT and test equipment were set up as shown on the following page.
- 2 The transmitter was turned on.
- 3 Sufficient attenuation was provided so that the transmitter carrier level measured at the output of the combiner was 40 dB below the maximum input level of the test receiver.
This level was recorded as step f.
- 4 The transmitter was turned off.
- 5 An RF signal generator (1) modulated with a 1 kHz tone at either 25 kHz or 12.5 kHz deviation, and set to the same frequency as the assigned transmitter frequency, (2) was adjusted to a level -20 dB below the level recorded for step f, as measured at the output of the combiner.
This level was then fixed for the remainder of the test and is recorded at step h.
- 6 The oscilloscope was setup using TIA-603C steps j and k as a guide, and to 10 msec./div.
- 7 The transmitter was turned on, and the level of the carrier at the output of the combiner was recorded as step l.
- 8 The carrier on-time as referenced in TIA-603-C steps m, n, and o was captured and plotted.
- 9 The carrier off-time as referenced in TIA-603-C steps p, q, r, and s was captured and plotted.

Measuring Equipments

No.	Equipment	Manufacture	Model No.	Serial No.	Cal Date	Cal Exp.
1	Signal Generator	Hewlett Packard	8657B	3247U03266	Dec. 25, 06	Dec. 31, 07
2	Oscilloscope	Tektronix	TDS 680B	B010292	Aug. 22, 06	Aug. 31, 07
3	Power Meter	Hewlett Packard	E4418B	GB38410404	Feb. 02, 07	Feb. 29, 08
4	Power Sensor	Hewlett Packard	8482A	US37292242	May. 26, 06	May. 31, 07
5	Attenuator (20dB)	Weinschel	40-20-34	AA5761	Jun. 15, 06	Jun. 30, 07
6	Attenuator (10dB)	TME	CFA-05NPJ-10	262856	Aug. 01, 06	Aug. 31, 07
7	Attenuator (10dB)	TME	CFA-05NPJ-10	262843	Aug. 01, 06	Aug. 31, 07
8	Modulation Analyzer	Hewlett Packard	8901B	3403A04852	Apr. 12, 06	Apr. 30, 07
9	Combiner(1)	Anritsu	Z-164A	M89549	Aug. 01, 06	Aug. 31, 07
10	Combiner(2)	Anritsu	Z-164A	M89249	Aug. 01, 06	Aug. 31, 07
11	Attenuator (3dB)	TME	CFA-20NPJ-3	679701	Aug. 01, 06	Aug. 31, 07
12	DC Power Supply	Daiwa	PS-3020	None	None	None
13	Digital Multi Meter	Sanwa	CD721	3040939	May 15, 06	May 31, 07

Test Results

Measured for the worst case

State : High Power / 25 kHz channel bandwidth:FM / 438.05 MHz / PTT:OFF -ON

Tek Run: 5.00kS/s Sample 17192

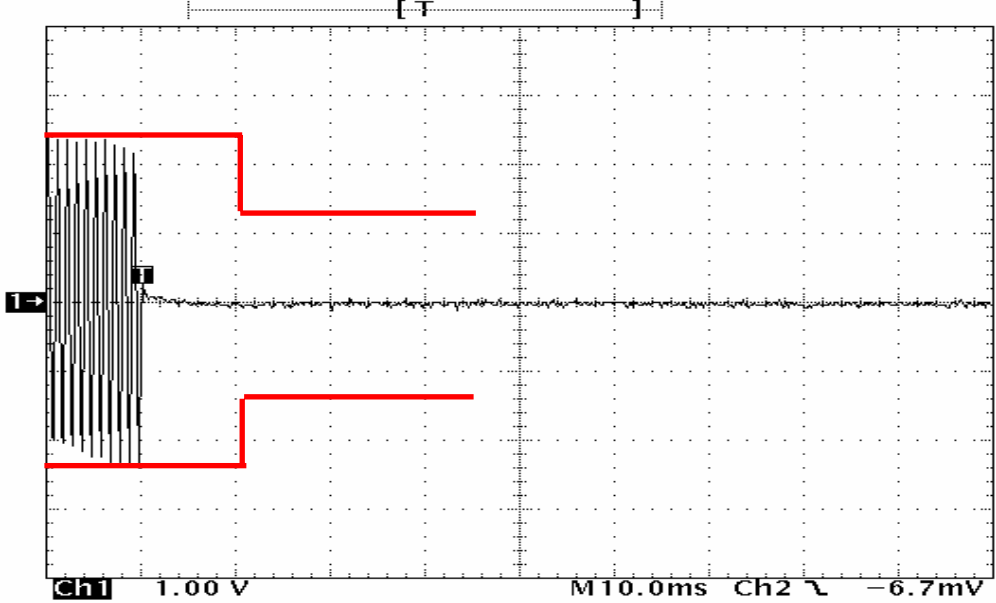

20 Mar 2007
10:11:50

State : High Power / 25 kHz channel bandwidth:FM / 438.05 MHz / PTT:ON -OFF

Tek stop: 5.00kS/s 10 Acqs

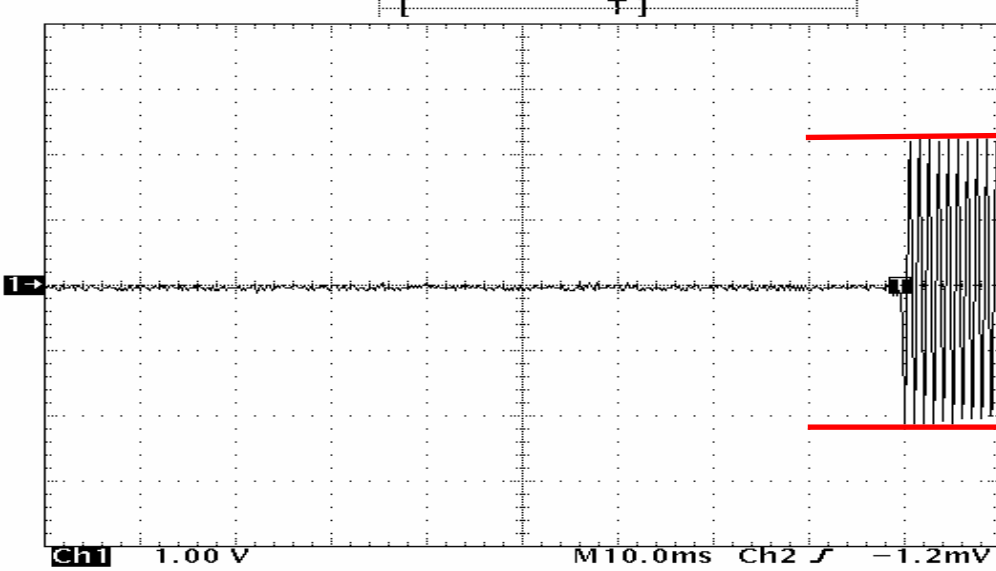

20 Mar 2007
11:07:30

State : High Power / 12.5 kHz channel bandwidth:FM / 438.05 MHz / PTT:OFF -ON

Tek Run: 5.00kS/s Sample 11192

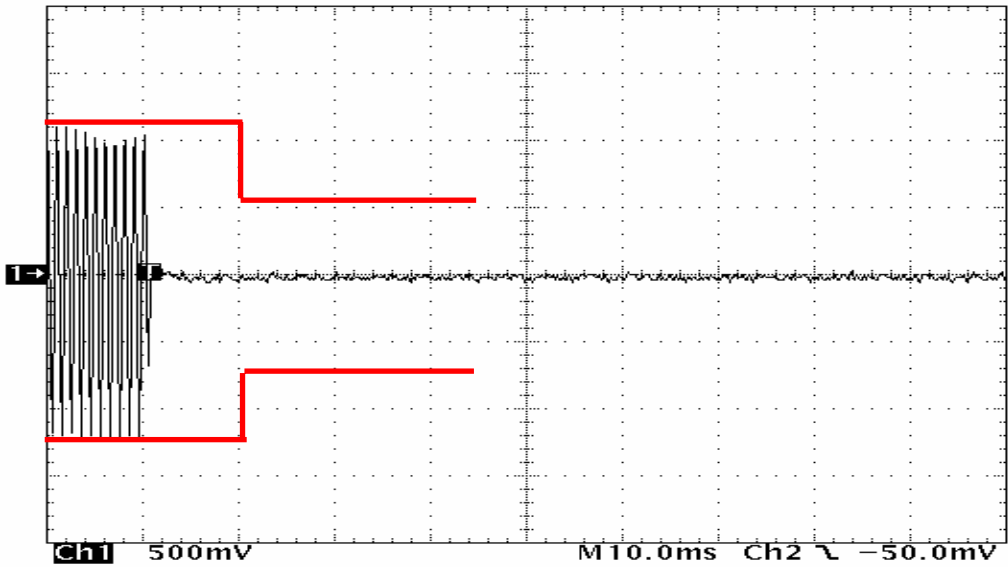

20 Mar 2007
09:36:24

State : High Power / 12.5 kHz channel bandwidth:FM / 438.05 MHz / PTT:ON -OFF

Tek Stop: 5.00kS/s 1 Acqs

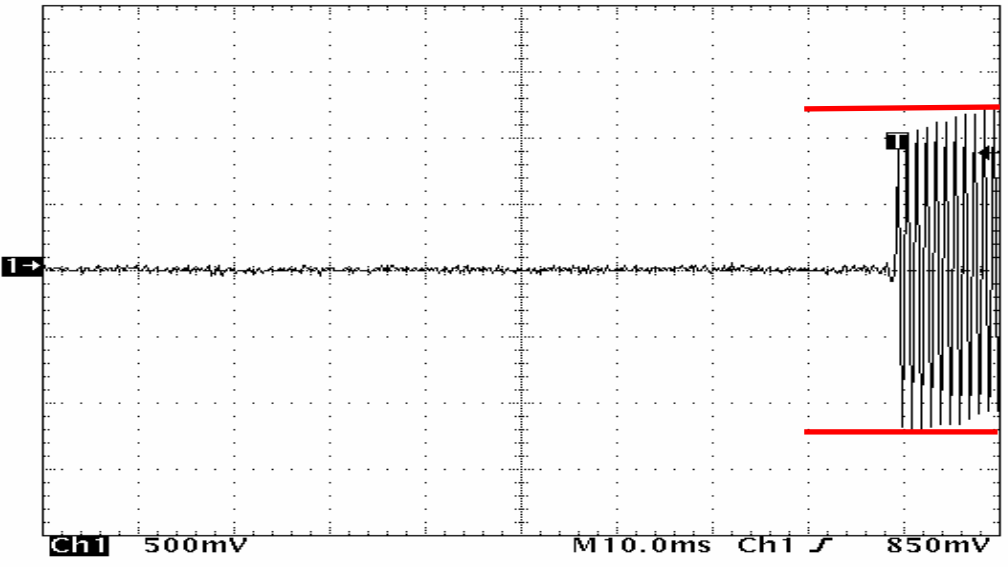

19 Mar 2007
16:30:57

5.6 Audio Frequency Response / Audio Low Pass Filter (Voice Input)

REGULATIONS	: 47 CFR 2.1047 (a)
TEST METHOD/GUIDE	: ANSI/TIA-603-C Section 2.2.6.2.2, 3.2.6.2

Test Procedure

- 1 The EUT and test equipment were set up as shown on the following page.
- 2 Adjust the Modulation Analyzer for the following setting:
 - a) High-pass filter : 50 Hz
 - b) Low-pass filter : 15 kHz
 - c) Detector : positive peak
 - d) Function : FM
- 3 The audio signal input was adjusted to obtain 20 % modulation at 1 kHz, and this point was taken as the 0 dB reference level.
- 4 With input levels held constant and below limiting at all frequencies, the audio signal generator was varied from 300 Hz to 20kHz (12.5kHz channel bandwidth) or 30 kHz (25kHz channel bandwidth).
- 5 The response in dB relative to 1 kHz was then measured, using the Modulation Analyzer.

Measuring Equipments

No.	Equipment	Manufacture	Model No.	Serial No.	Cal Date	Cal Exp.
1	Audio Generator	Anritsu	MG443B	M70150	Aug. 25, 06	Aug. 31, 07
2	Attenuator (20dB)	Weinschel	40-20-34	AA5761	Jun. 15, 06	Jun. 30, 07
3	Attenuator (30dB)	Weinschel	WA-29-30-34	8923	Jun. 15, 06	Jun. 30, 07
4	Modulation Analyzer	HP	8901B	3403A04852	Apr. 12, 06	Apr. 30, 07
5	Audio Analyzer	HP	8903B	2948A07326	Apr. 18, 06	Apr. 30, 07
6	DC Power Supply	Daiwa	PS-3020	None	None	None
7	Digital Multi Meter	Sanwa	CD721	3215593	May. 15, 06	May 31, 07

Measuring Cables

No.	Cable	Manufacture	Model No.	Serial No.	Cal Date	Cal Exp.
W1	Coaxial Cable	Suhner	SUCOFLEX102	KSR00046	Aug. 01, 06	Aug. 31, 07
W2	Coaxial Cable	Pacific custom	RG-58 C/U	AM90C02	Aug. 01, 06	Aug. 31, 07
W5	Balance Cable	Nicoon	3D-2V	KSR00092	Oct. 01, 06	Oct. 31, 07
W8	Coaxial Cable	Pacific custom	RG-58 C/U	KSR00094	Oct. 01, 06	Oct. 31, 07

Measuring Equipment Configuration

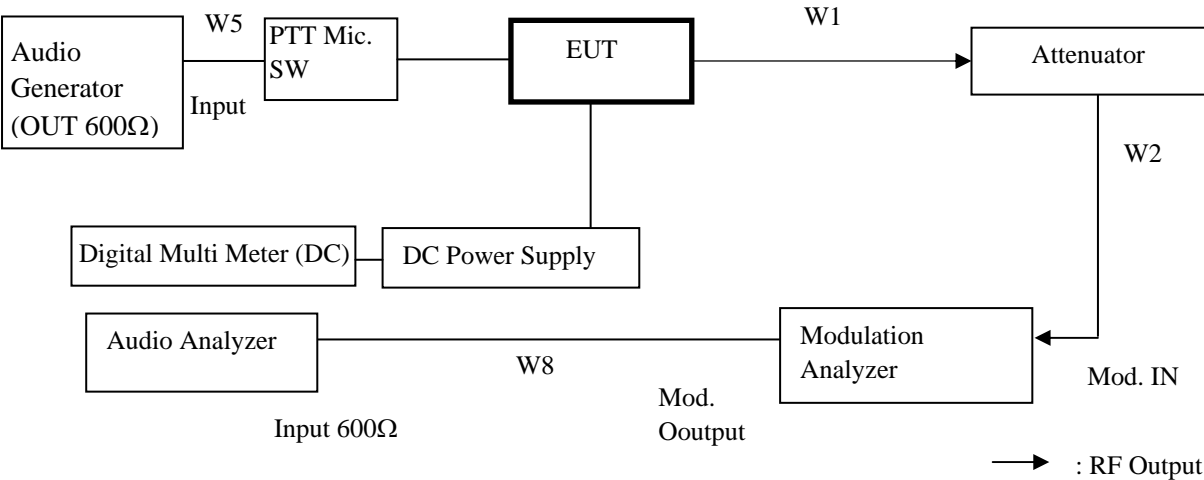

Uncertainty

Measurement uncertainty is +/- 0.3dB (k = 2)

Test Results

Measured for the worst case

State : High Power / 25 kHz channel bandwidth / 438.05 MHz

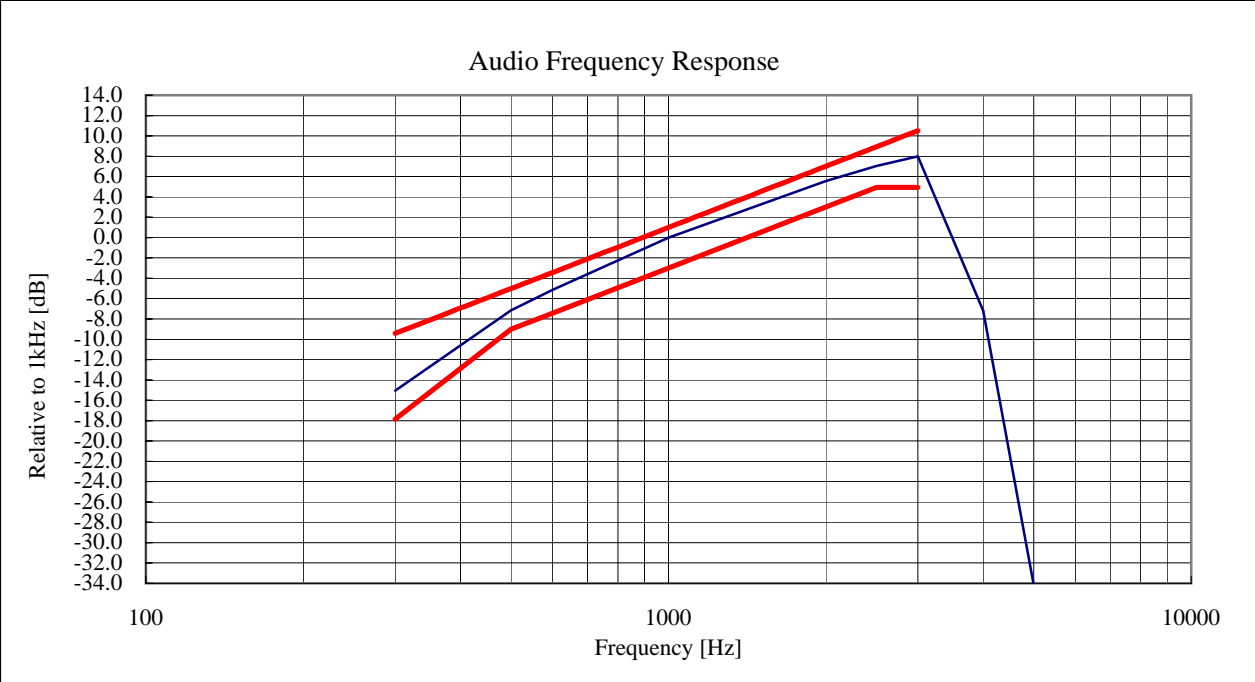

State : High Power / 12.5 kHz channel bandwidth / 438.05 MHz

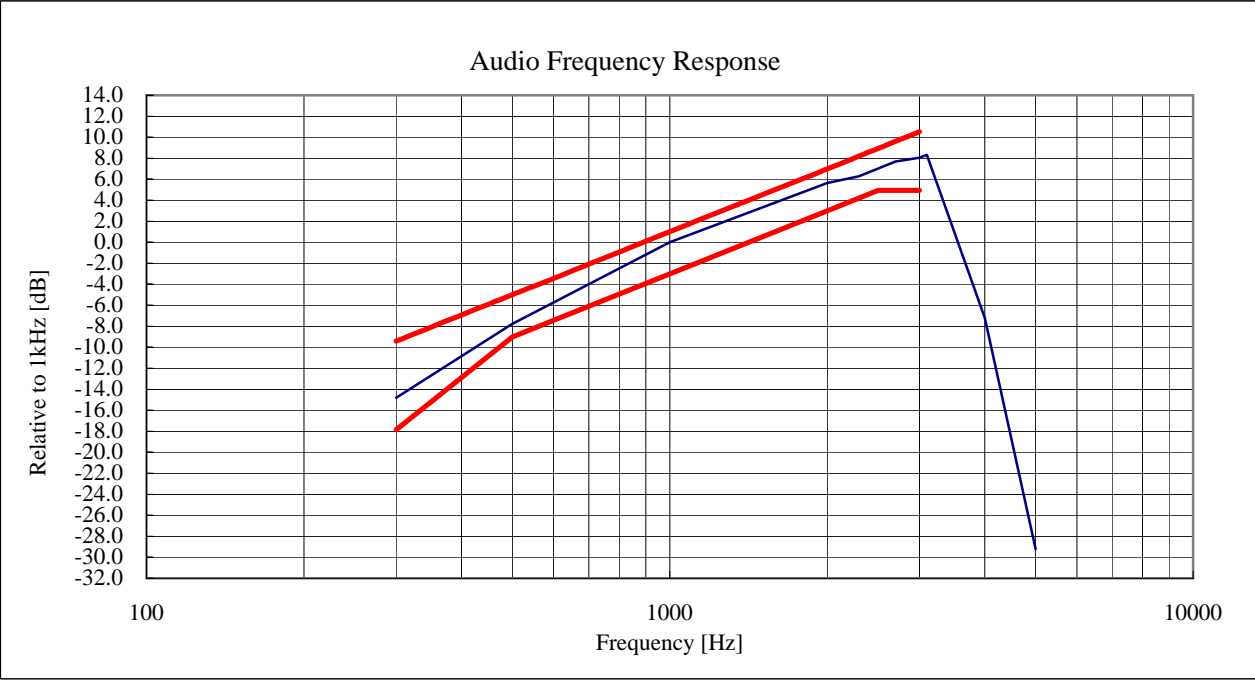

Note:
 Audio Filter of the above result is substituted with the same structure as Audio Frequency Resonse.
 On the transmission condition below 3kHz, Transceiver shows pre-emphasis condition of transmission function.
 On the transmission condition above 3kHz, Transceiver shows Audio Low Pass Filter.

5.7 Modulation Limiting

REGULATIONS	: 47 CFR 2.1047 (b)
TEST METHOD/GUIDE	: ANSI/TIA-603-C Section 2.2.3.2, 1.3.4.4

Test Procedure

- 1 The EUT and test equipment were set up as shown on the following page.
- 2 Adjust the Modulation Analyzer for the following setting:
 - a) High-pass filter : off
 - b) Low-pass filter : 15 kHz
 - c) Detector : positive peak
 - d) Function : FM
- 3 Apply a 1kHz modulation signal to the transmitter from the audio generator, and adjust the level to obtain 60% of full rated system deviation.
- 4 Measure the modulation frequency that was showed on the Modulation Analyzer when the output levels of the Audio Generator were changed from -20 dB to +50 dB by 10 dB.
- 5 Set the output frequencies of the Audio Generator 300 Hz and 3 kHz, and repeat test procedure 4.
- 6 Set the the Detector of the Modulation Analyzer Negative Peak.
- 7 Repeat test procedure 4 and 5.

Measuring Equipments

No.	Equipment	Manufacture	Model No.	Serial No.	Cal Date	Cal Exp.
1	Audio Generator	Anritsu	MG443B	M70150	Aug. 25, 06	Aug. 31, 07
2	Attenuator (20dB)	Weinschel	40-20-34	AA5761	Jun. 15, 06	Jun. 30, 07
3	Attenuator (30dB)	Weinschel	WA-29-30-34	8923	Jun. 15, 06	Jun. 30, 07
4	Modulation Analyzer	HP	8901B	3403A04852	Apr. 12, 06	Apr. 30, 07
5	DC Power Supply	Daiwa	PS-3020	None	None	None
6	Digital Multi Meter	Sanwa	CD721	3215593	May 15, 06	May 31, 07

Measuring Cables

No.	Cable	Manufacture	Model No.	Serial No.	Cal Date	Cal Exp.
W1	Coaxial Cable	Suhner	SUCOFLEX102	KSR00046	Aug. 01, 06	Aug. 31, 07
W2	Coaxial Cable	Pacific custom	RG-58 C/U	AM90C02	Aug. 01, 06	Aug. 31, 07
W5	Balance Cable	Nicoon	3D-2V	KSR00092	Oct. 01, 06	Oct. 31, 07

Measuring Equipment Configuration

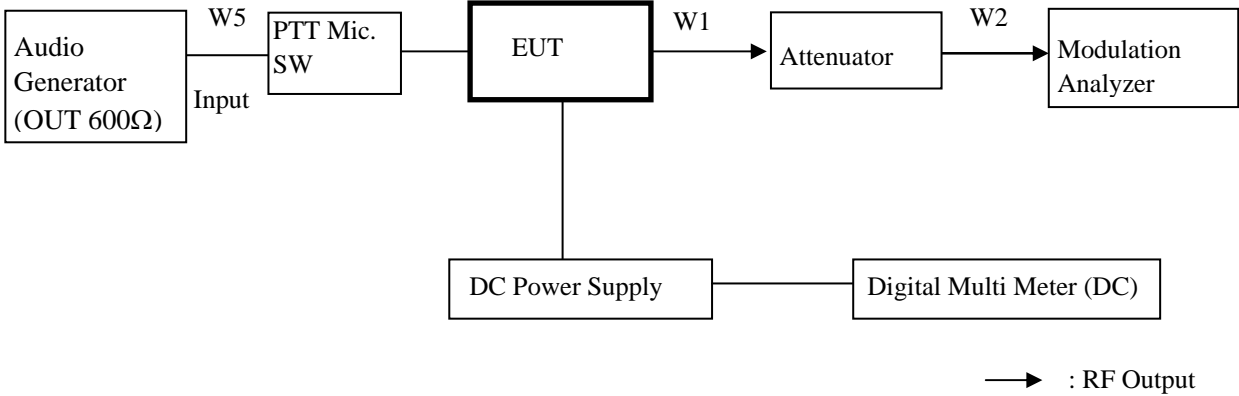

Uncertainty

Measurement uncertainty is +/- 0.3dB (k = 2)

Test Results

Measured for the worst case

State : High Power / 25 kHz channel bandwidth / 438.05 MHz

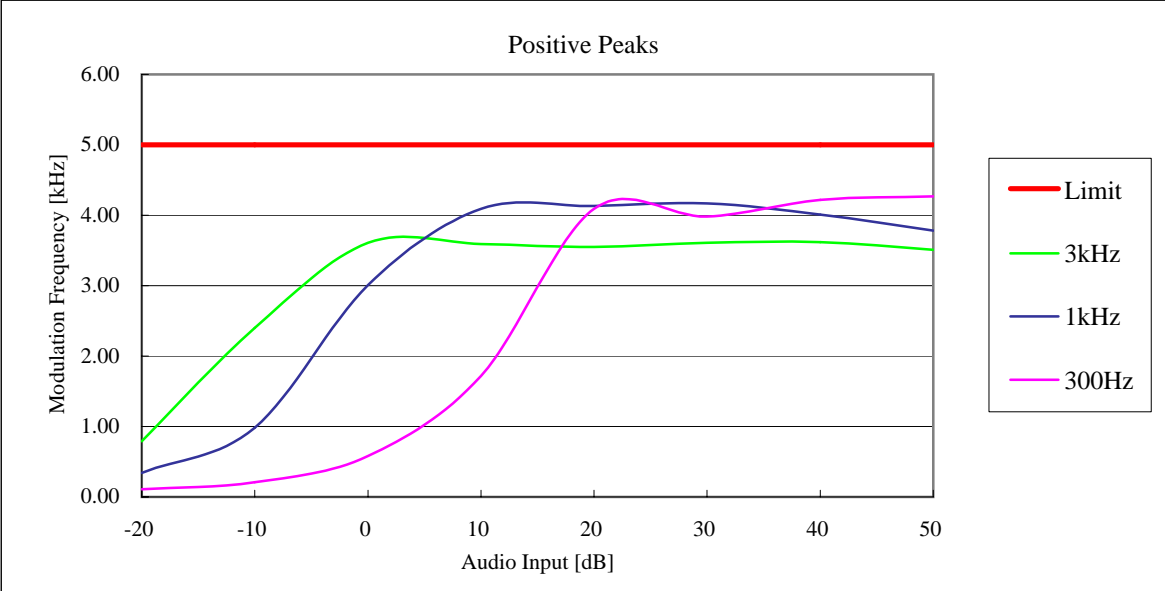

State : High Power / 25 kHz channel bandwidth / 438.05 MHz

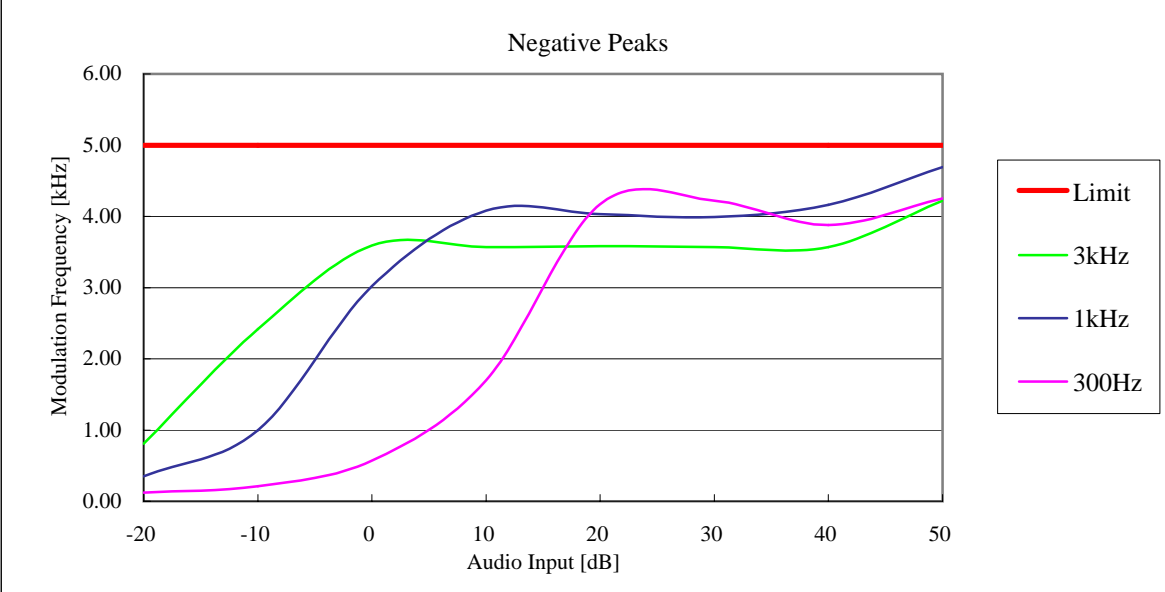

State : High Power / 12.5 kHz channel bandwidth / 438.05 MHz

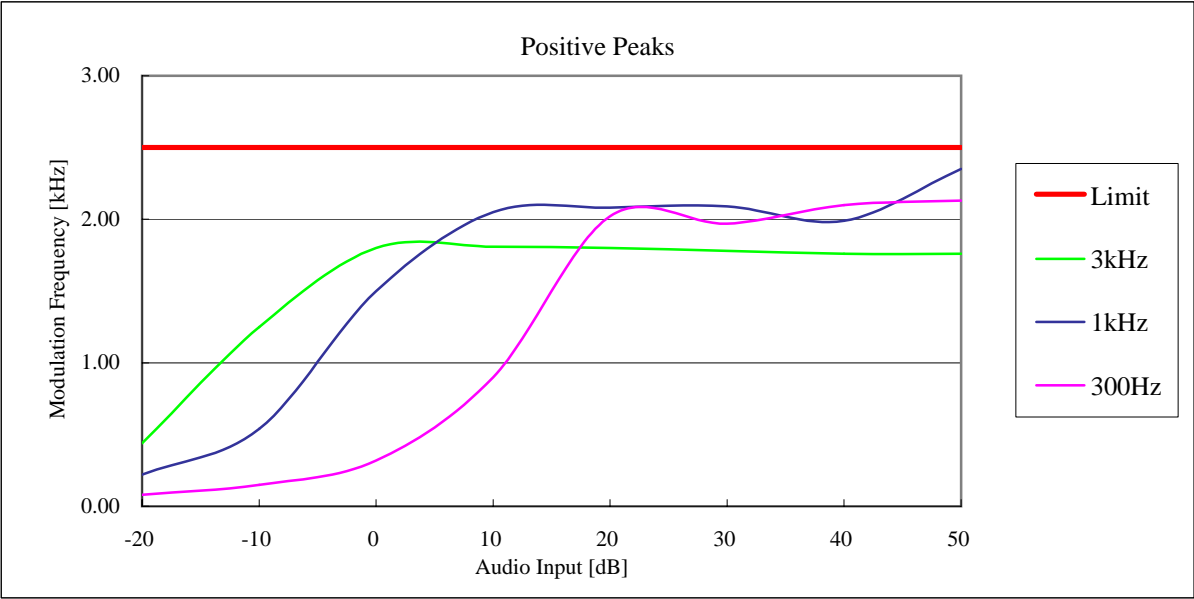

State : High Power / 12.5 kHz channel bandwidth / 438.05 MHz

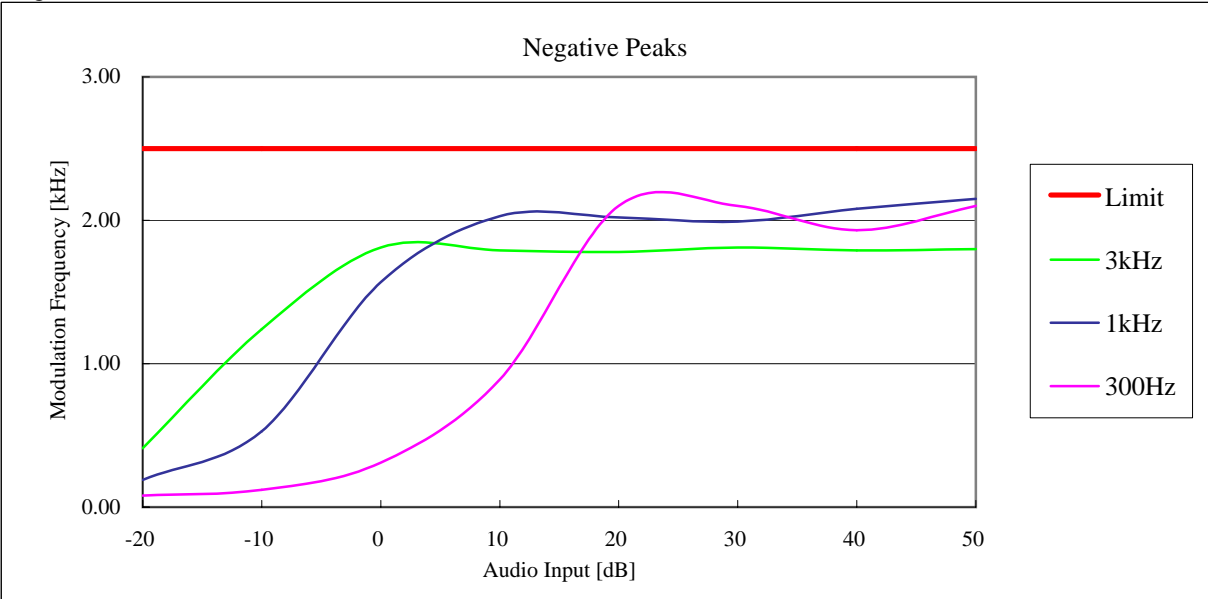

5.8 Frequency Stability (Temperature Variation)

REGULATIONS	: 47 CFR 2.1055 (a) (1), 22.355 , 74.1261 (b) , 90.213(a)
TEST METHOD/GUIDE	: ANSI/TIA-603-C Section 2.2.2.2

Test Procedure

- 1 The EUT and test equipment were set up as shown on the following page.
- 2 Set the temperature -30 degrees C.
- 3 Leave the EUT for 1 hour after it became the temperature that was set up.
- 4 Make the EUT the transmitting state.
Two minutes later, measure the output frequency.
- 5 Make the EUT the receiving state.
- 6 Set the temperature 50 degrees C by 10 degrees C.
And repeat test procedure 3 to 5.

Measuring Equipments

No.	Equipment	Manufacture	Model No.	Serial No.	Cal Date	Cal Exp.
1	Spectrum Analyzer	Agilent	E4407B	MY45102460	Oct. 03, 06	Oct. 31, 07
2	Attenuator (20dB)	Weinschel	40-20-34	AA5761	Jun. 15, 06	Jun. 30, 07
3	Attenuator (30dB)	Weinschel	WA-29-30-34	8923	Jun. 15, 06	Jun. 30, 07
4	DC Power Supply	Daiwa	PS-3020	None	None	None
5	Digital Multimeter	Sanwa	CD721	3215593	May 15, 06	May 31, 07
6	Temperature Chamber	Tabai	PL-3F	5103661	None	None
7	Temperature Meter	Sato	PC-5000TRH-II	A11999972	Mar. 22, 07	Mar. 31, 08

Measuring Cables

No.	Cable	Manufacture	Model No.	Serial No.	Cal Date	Cal Exp.
W1	Coaxial Cable	Suhner	SUCOFLEX102	KSR00046	Aug. 01, 06	Aug. 31, 07
W2	Coaxial Cable	Pacific custom	RG-58 C/U	AM90C02	Aug. 01, 06	Aug. 31, 07

Measuring Equipment Configuration

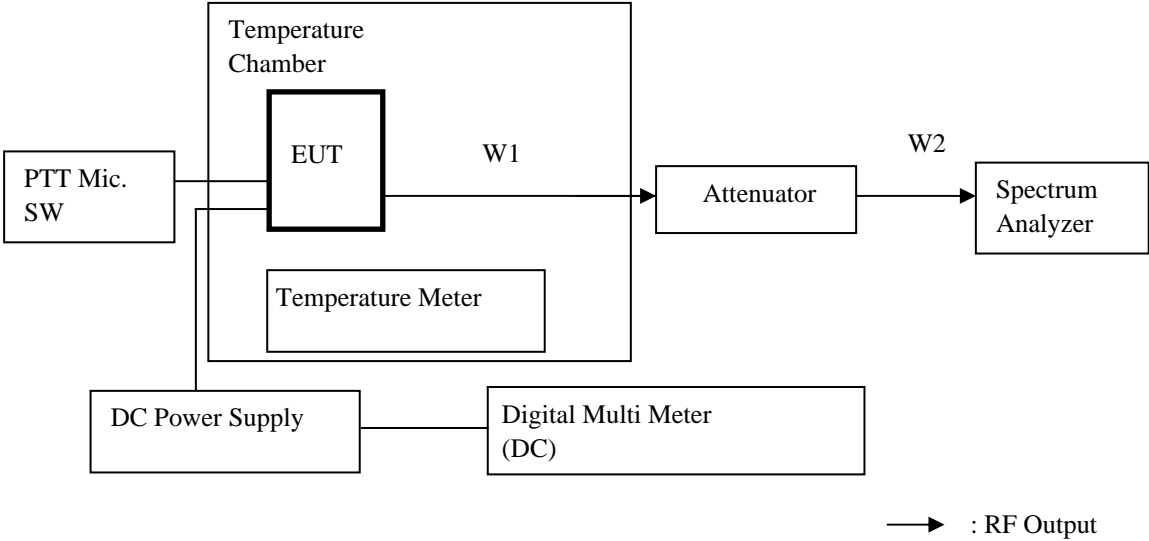

Uncertainty

Measurement uncertainty is +/- 0.2ppm

Test Results

Measured for the worst case

State : High Power / 12.5 kHz channel bandwidth / 406.15 MHz

No.	Temperature (Degree C)	Frequency (MHz)	Stability (ppm)	Limit (ppm)
1	-30	406.149935	-0.16	2.5
2	-20	406.149960	-0.10	2.5
3	-10	406.149934	-0.16	2.5
4	0	406.149939	-0.15	2.5
5	10	406.150095	0.23	2.5
6	20	406.150132	0.33	2.5
7	30	406.150135	0.33	2.5
8	40	406.150132	0.33	2.5
9	50	406.150042	0.10	2.5

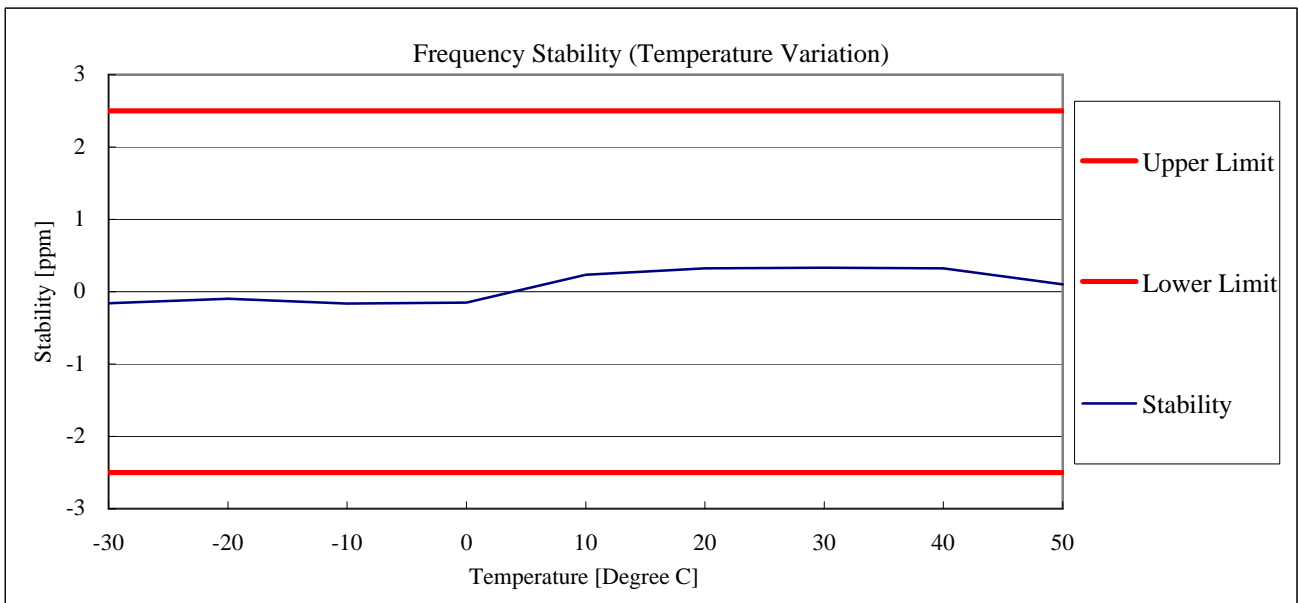

5.9 Frequency Stability (Voltage Variation)

REGULATIONS	: 47 CFR 2.1055 (d) (1), 22.355 , 74.1261 (b) , 90.213(a)
TEST METHOD/GUIDE	: ANSI/TIA-603-C Section 2.2.2.2

Test Procedure

- 1 The EUT and test equipment were set up as shown on the following page.
- 2 The power supply voltage to the EUT was varied from 85 % to 115 % of the nominal value measured at the input to the EUT.

Measuring Equipments

No.	Equipment	Manufacture	Model No.	Serial No.	Cal Date	Cal Exp.
1	Spectrum Analyzer	Agilent	E4407B	MY45102460	Oct. 03, 06	Oct. 31, 07
2	Attenuator (20dB)	Weinschel	40-20-34	AA5761	Jun. 15, 06	Jun. 30, 07
3	Attenuator (30dB)	Weinschel	WA-29-30-34	8923	Jun. 15, 06	Jun. 30, 07
4	DC Power Supply	Daiwa	PS-3020	None	None	None
5	Digital Multimeter	Sanwa	CD721	3215593	May 15, 06	May 31, 07
6	Temperature Chamber	Tabai	PL-3F	5103661	None	None
7	Temperature Meter	Sato	PC-5000TRH-II	A11999972	Mar. 22, 07	Mar. 31, 08

Measuring Cables

No.	Cable	Manufacture	Model No.	Serial No.	Cal Date	Cal Exp.
W1	Coaxial Cable	Suhner	SUCOFLEX102	KSR00046	Aug. 01, 06	Aug. 31, 07
W2	Coaxial Cable	Pacific custom	RG-58 C/U	AM90C02	Aug. 01, 06	Aug. 31, 07

Measuring Equipment Configuration

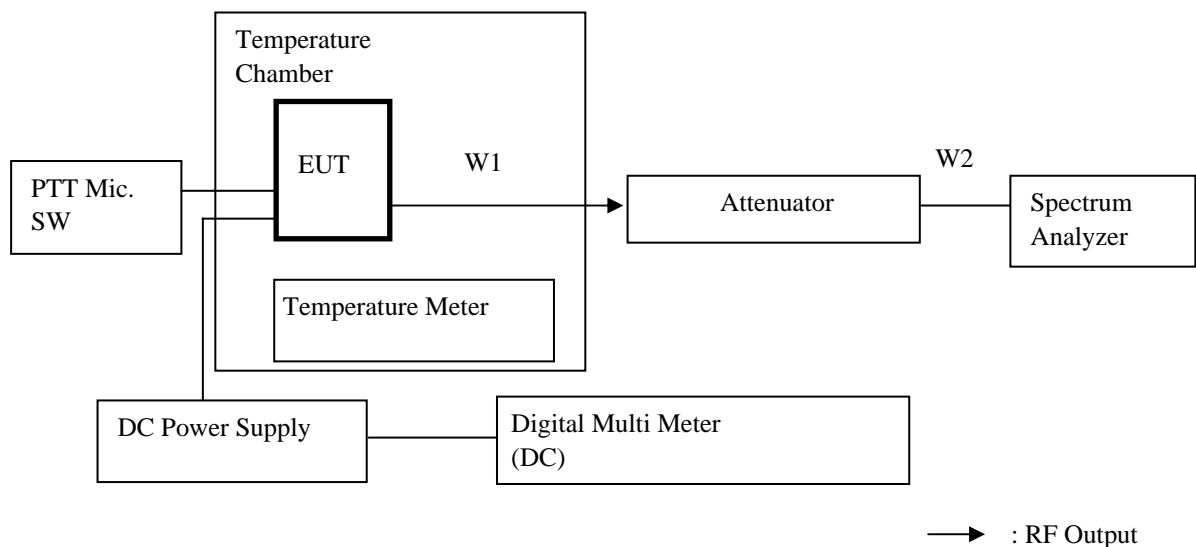

Uncertainty

Measurement uncertainty is +/- 0.2ppm

Test Results

Measured for the worst case

State : High Power / 12.5 kHz channel bandwidth / 406.15 MHz

No.	Diviation (%)	Voltage (V)	Frequency (MHz)	Stability (ppm)	Limit (ppm)
1	85	11.4	406.150133	0.33	2.5
2	100	13.4	406.150133	0.33	2.5
3	115	15.4	406.150133	0.33	2.5

5.10 Necessary Bandwidth and Emission Bandwidth

REGULATIONS	: 47 CFR 2.202 (g) & Federal Register/ Vol.68, No236
-------------	--

Calculation Results

State : 16K0F3E(25kHz channel bandwidth)

Item	Mark	
Maximum Modulation	(M)	3kHz
Maximum Deviation	(D)	5kHz
Constant Factor	(K)	1
Necessary Bandwidth	(Bn)	16kHz

$$B_n = (2 \times M) + (2 \times D \times K)$$

State : 11K0F3E(12.5kHz channel bandwidth)

Item	Mark	
Maximum Modulation	(M)	3kHz
Maximum Deviation	(D)	2.5kHz
Constant Factor	(K)	1
Necessary Bandwidth	(Bn)	11kHz

$$B_n = (2 \times M) + (2 \times D \times K)$$

State : 20K0F7D(4Level FSK/19200bps, 25kHz channel bandwidth)

Item	Mark	
Digital information rate	(R)	19200bps
Peak frequency deviation	(D)	5.2kHz
Signaling states	(S)	4
Numerical factor	(K)	1
Necessary Bandwidth	(Bn)	20kHz

$$B_n = (R / \log_2 S) + 2 \times D \times K$$

State : 11K2F7D(4Level FSK/9600bps, 12.5kHz channel bandwidth)

Item	Mark	
Digital information rate	(R)	9600bps
Peak frequency deviation	(D)	3.2kHz
Signaling states	(S)	4
Numerical factor	(K)	1
Necessary Bandwidth	(Bn)	11.2kHz

$$B_n = (R / \log_2 S) + 2 \times D \times K$$

State : 14K4F1D(GMSK/9600bps, 25kHz channel bandwidth)

Item	Mark	
Digital information rate	(R)	9600bps
Peak frequency deviation	(D)	2.4kHz
Signaling states	(S)	2
Constant Factor	(K)	1
Necessary Bandwidth	(Bn)	14.4kHz

$$B_n = (R/\log_2 S) + 2xDxK$$

State : 7K20F1D(GMSK/4800bps, 12.5kHz channel bandwidth)

Item	Mark	
Digital information rate	(R)	4800bps
Peak frequency deviation	(D)	1.2kHz
Signaling states	(S)	2
Constant Factor	(K)	1
Necessary Bandwidth	(Bn)	7.2kHz

$$B_n = (R/\log_2 S) + 2xDxK$$

State : 8K10F1D/8K10F1E(C4FM/9600bps, 12.5kHz channel bandwidth)

Item	Mark		
Digital information rate	(R)	9600bps	
Peak frequency deviation	(D)	4.5kHz	
Signaling states	(S)	4	
Numerical factor	(K)	1	
Necessary Bandwidth	(Bn)	8.1kHz	Measurements were done*

*Measurements per Rule 47CFR Part 2.202(c)(4) were done because Part 2.202(g) Table III-A.1. formulation produces an excessive result using the value of K recommended in the Table. Therefore the 99% energy rule(title 47CFR 2.202(a)) was used for digital mode and is more accurate than Carson's rule. It basically states that 99% of the modulation energy falls within X kHz, in this case, 8.10kHz. Measurements were performed in accordance with TIA/EIA 102.CAAA-A Section 2.2.5.2. The emission mask was obtained from 47CFR 90.210(d).



6. VALIDITY OF TEST REPORT





The test result of this report is effective for equipment under test itself and under the test configuration described on the report.

This test report does not assure that whether the test result taken in other testing laboratory is compatible or reproducible to the test result on this report or not.

Copying of this report without permission is prohibited.

7. DESCRIPTION OF TEST LABORATORY

ACCREDITATION			SCOPE	LAB. CODE
	NVLAP	USA	EMC Testing	100290-0
	NVLAP	USA	Calibration	100290-0
	NVLAP	USA	Telecommunication	100290-0
	VLAC	JAPAN	EMC Testing	VLAC-008-1
	BSMI	TAIWAN	EMC Testing	SL2-IN-E-6008
	NATA	AUSTRALIA	Calibration	13491
	NATA	AUSTRALIA	Telecommunication	100290-0

FILING			SCOPE	LAB. CODE
	VCCI	JAPAN	EMC Testing	
	FCC	USA	EMC Testing	934283
	IC	CANADA	EMC Testing	IC-2065A
	IC	CANADA	Telecommunication	IC-2065A
		SAUDI ARABIA	EMC Testing	

Note 1 : NVLAP accreditation does not constitute any product endorsement by NVLAP or any agent of the U.S. Government.