



TEST REPORT

**STANDARD : FCC Part15B Class B –Scanning Receiver-
Industry Canada RSS-135 Issue 2**

Applicant	Testing Laboratory
JVC KENWOOD Corporation 1-16-2, Hakusan, Midori-ku, Yokohama-shi, Kanagawa, 226-8525 Japan Tel. +81 45 939 6254	Intertek Japan K.K. Kashima Laboratory URL: http://www.japan.intertek-etlsemko.com (Open area test site) 3-2 Sunayama, Kamisu, Ibaraki 314-0255 Japan Tel. +81 479 40 1097 (Anechoic chamber) 298-6 Sada, Kashima, Ibaraki 314-0027 Japan Tel. +81 299 82 8464

Equipment Type	144/440MHz FM DUAL BANDER
Trademark	KENWOOD
Model(s)	TM-D710GA
Serial No.	B3600176
Equipment Authorization	Certification (FCC ID : K44397700) (IC CN and UPN : 282F-397700)
Test Result	Complied
Report Number	13070409JKA-003
Original Issue Date	August 26, 2013

This report is for the exclusive use of Intertek's Client and is provided pursuant to the agreement between Intertek and its Client. Intertek's responsibility and liability are limited to the terms and conditions of the agreement. Intertek assumes no liability to any party, other than to the Client in accordance with the agreement, for any loss, expense or damage occasioned by the use of this report. Only the Client is authorized to permit copying or distribution of this report and then only in its entirety. Any use of the Intertek name or one of its marks for the sale or advertisement of the tested material, product or service must first be approved in writing by Intertek. The observations and test results in this report are relevant only to the sample tested. This report by itself does not imply that the material, product, or service is or has ever been under an Intertek certification program.

Approved by *K. Gokita*
Kazuo Gokita
[Manager]

Tested by *K. Wagatsuma*
Koichi Wagatsuma



Tested by *K. Uchida*
Katsuya Uchida

Responsible Party of Test Item (Product)

Responsible Party	:
Add.	:
Tel.	:
Fax.	:
Contact Person	:

TABLE OF CONTENTS

	Page
SECTION 1. GENERAL INFORMATION	3
SECTION 2. SUMMARY OF TEST RESULTS	4
SECTION 3. EQUIPMENT UNDER TEST	5
SECTION 4. SUPPORT EQUIPMENT.....	7
SECTION 5. USED CABLE(S).....	8
SECTION 6. TEST CONFIGURATION	9
SECTION 7. OPERATING CONDITION	11
SECTION 8. UNCERTAINTY	12
SECTION 9. EVALUATION OF TEST RESULTS	13
SECTION 10. LIST OF MEASURING INSTRUMENTS.....	70
ANNEX	72
APPENDIX Photographs of Test Setup	

SECTION 1. GENERAL INFORMATION

Test Performed

EUT Received	July 31, 2013
Date of Test	From July 31, 2013 to August 19, 2013
Standard Applied	FCC Part15B Class B – Scanning Receiver – Industry Canada RSS-135 Issue 2* *It is not covered by accredited scope of VLAC.
Test methods	ANSI C63.4-2003 / RSS-GEN Issue 3 -2010
Deviation from Standard(s)	None

Note : As for the ICES-003 "Digital Apparatus", the EUT has been measured.

Refer to report No. 13070409JKA-002.

As for the FCC Part15B Class B "Peripherals", the EUT has been measured.

Refer to report No. 13070409JKA-001.

Qualifications of Testing Laboratory

Accreditation	Scope	Lab. Code	Remarks
NVLAP	EMC Testing	100290-0	USA
VLAC	EMC Testing	VLAC-008-1	JAPAN
BSMI	EMC Testing	SL2-IN-E-6008	TAIWAN
Filing			
VCCI	EMC Testing	A-0126	JAPAN
FCC	EMC Testing	Designation Number : JP0008	USA
IC	EMC Testing	2042K-1, 2042K-3, 2042Q-12	CANADA
CB-Scheme	EMC Testing	TL222	IECEE
SAUDI ARABIA	EMC Testing	N/A	

Abbreviations

EUT	Equipment Under Test	DoC	Declaration of Conformity
AMN	Artificial Mains Network	ISN	Impedance Stabilization Network
LISN	Line Impedance Stabilization Network	Q-P	Quasi-peak
AMP	Amplifier	AVG	Average
ATT	Attenuator	PK	Peak
ANT	Antenna	Cal	Calibration
BBA	Broadband Antenna	N/A	Not applicable or Not available
DIP	Dipole Antenna	LCD	Liquid-Crystal Display
AE	Associated Equipment	HDMI	High-Definition Multimedia Interface

SECTION 2. SUMMARY OF TEST RESULTS

See Section9 for the detailed result.

Emission Tests

Standard Applied	FCC Part15B Class B – Scanning Receiver – Industry Canada RSS-135 Issue 2	
Test Item	Minimum margin	Remarks
Conducted disturbance at mains terminals	5.1 dB (0.2035 MHz) [QP] RX mode(A Band :118.05MHz/B Band :136.05MHz)	
Radiated disturbance	4.3 dB (948.01 MHz) RX mode(A Band :523.95MHz/B Band :523.95MHz)	
Conducted power on antenna port	9.8 dB (349.9558 MHz) VFO SCAN mode(A Band :300MHz Band/B Band :300MHz Band)	

Test Item	Results/ Minimum margin	Remarks
38dB Rejection test (15.121(b))	Pass / 15dB (Injected Frequency 881.505 MHz/ Detected Frequency 856.530 MHz / VFO SCAN mode (B Band : 800MHz - 1300MHz))	

SECTION 3. EQUIPMENT UNDER TEST

The equipment under test (EUT) consisted of the following apparatus.

3.1 System Configuration

Symbol	Item	Model No.	Serial No.	Manufacturer	Remarks
A1	144/440MHz FM DUAL BANDER (Main Unit)	TM-D710GA	B3600176	JVC KENWOOD Corporation	
A2	144/440MHz FM DUAL BANDER (Panel Unit)	TM-D710GA	B3600176	JVC KENWOOD Corporation	
Rated Power : DC 13.8V±15%, 13A					
Supplied Power : DC 13.8V					
Condition of Equipment		Prototype			
Type		Tabletop			
Suppression Devices		No Modifications by the laboratory were made to the device			

3.2 Overview of EUT

Frequency ranges	A Band:118 - 524MHz B Band:136 - 524MHz, 800 - 824MHz, 849 - 869MHz, 894 - 1300MHz
Receiver Type	Double-conversion
Model of operation	F1D, F2D, F3E

3.3 Intermediate Frequency

1st	A Band:45.05MHz / B Band:49.95MHz
2nd	A Band:455kHz / B Band:450kHz

3.4 Highest Frequency Generated / Used

Operating Frequency	Operating mode	Remarks
3144.84 MHz	GPS mode	

3.5 Port(s)/Connector(s)

Port Name	Connector Type	Connector Pin	Remarks
ANT	M	1 pin	
DATA	Mini DIN	6 pin	
PC	Mini DIN	8 pin	
SP 1	Mini Jack(3.5 ϕ)	1 pin	
SP 2	Mini Jack(3.5 ϕ)	1 pin	
MIC	Modular	8 pin	
PANEL	Modular	8 pin	
PANEL	Modular	8 pin	
PANEL	Modular	6 pin	
PC	Mini DIN	6 pin	
GPS	Mini Jack(2.5 ϕ)	1 pin	

SECTION 4. SUPPORT EQUIPMENT

The EUT was supported by the following equipment during the test.

Symbol	Item	Model No.	Serial No.	Manufacturer	FCC ID
B	Microphone	MC-59	None	JVC KENWOOD Corporation	N/A
C	DC Power Supply	PS-60	11/01 00148	JVC KENWOOD Corporation	N/A
D	External Speaker	SP-50B	None	JVC KENWOOD Corporation	N/A
E	External Speaker	SP-50B	None	JVC KENWOOD Corporation	N/A
F	USB Adaptor	KCT-53U	None	JVC KENWOOD Corporation	K44403500
G	Weather Sensor	WS2103	2405220CC	PEET BROS.COMPANY	KG7WS2103
H	Computer	MTC2	GZNP1X	DELL	DoC
I	LCD	E151FPb	CN-04W569-4663 3-363-1DLT	DELL	DoC
J	Mouse	M-SAW34	LZC31257181	DELL	DZL211029
K	Keyboard	SK-8110	CN-07N247-7161 6-44Q-090P	DELL	DoC
L	Printer	C6490B	MY35G1R0XP	Hewlet Packard	DoC
M	AC Adaptor	0950-4401	6100394005	Hewlet Packard	N/A
N	Terminator	CT-03BP	None	TME	N/A
O	Junction Box	None	None	PEET BROS.COMPANY	N/A
P	AC Adaptor	SER-12400G	None	PEET BROS.COMPANY	N/A
Supplied Power:					
C, H, I, P, M		AC120 V, 60 Hz			

SECTION 5. USED CABLE(S)

The following cable(s) was used for the test.

No.	Name	Length (m)	Shield	Metal Connector	Ferrite Core
1	Operation Control cable	4.0	Yes	No	
2	Extension cable (PG-5F)	4.0	Yes	No	
3	Microphone cable	0.6	Yes	No	
4	Extension cable (PG-5F)	4.0	Yes	No	
5	Serial Communication Cable (PG-5H)	2.0	Yes	Yes	
6	Data Communication Cable (PG-5H)	2.0	Yes	Yes	
7	Extension cable (PG-5F)	2.0	Yes	Yes	
8	Speaker cable	2.5	Yes	Yes	
9	Speaker cable	2.5	Yes	Yes	
10	Serial Communication Cable (PG-5G)	2.0	Yes	Yes	
11	Data cable	1.9	No	No	
12	Video cable	1.9	Yes	Yes	Fixed x 1
13	Mouse cable	2.0	Yes	Yes	
14	Keyboard cable	2.0	Yes	Yes	
15	Centronics cable	2.5	Yes	Yes	
16	Power cable for TM-D710GA (DC)(PG-5F)	6.0	No	No	
17	Power cable for DC Power Supply	1.8	No	No	
18	Power cable for Computer	2.0	No	No	
19	Power cable for LCD	2.2	No	No	
20	Power cable for Printer (DC)	2.0	No	No	Fixed x 1
21	Power cable for Printer	2.2	No	No	
22	USB cable	2.5	No	Yes	
23	Power cable for Junction Box (DC)	1.8	No	No	
24	Junction Box cable	3.0	No	No	
25	Temperature Sensor cable	8.0	No	No	

Note : 1. No.12 cable is supplied together with LCD(I) .
 2. No.20 cable is supplied together with Printer(L) .

SECTION 6. TEST CONFIGURATION

6.1 Conducted disturbance at mains port and Radiated disturbance RX mode and VFO Scan mode

* : EUT
 ■ : Ferrite core
 □ : Joint Connector

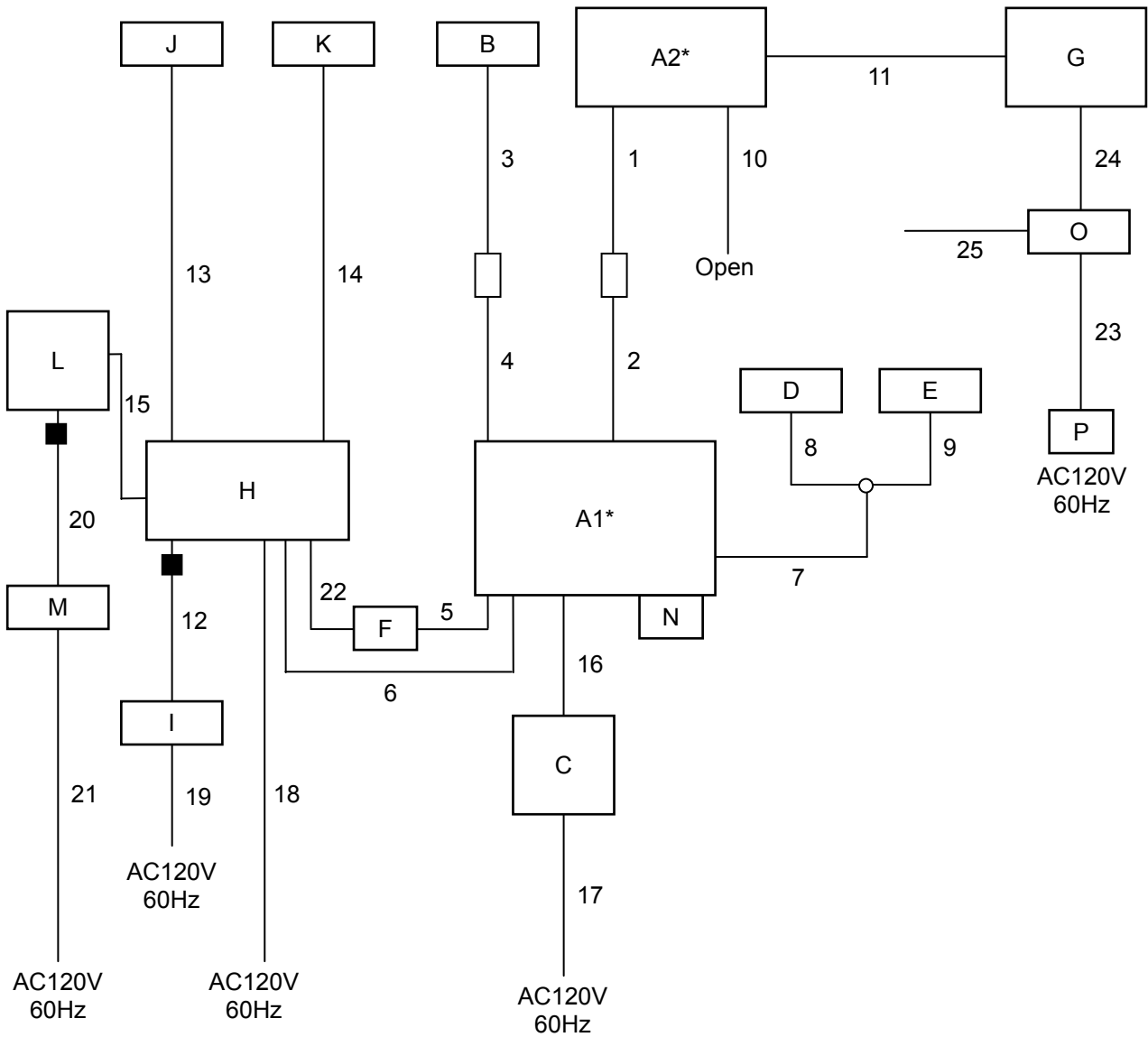

The symbols and numbers assigned to the equipments and cables on this diagram correspond to the ones in Sections 3 to 5.

6.2 Conducted power on antenna port and 38dB Rejection test
RX mode and VFO Scan mode

* : EUT
■ : Ferrite core
□ : Joint Connector

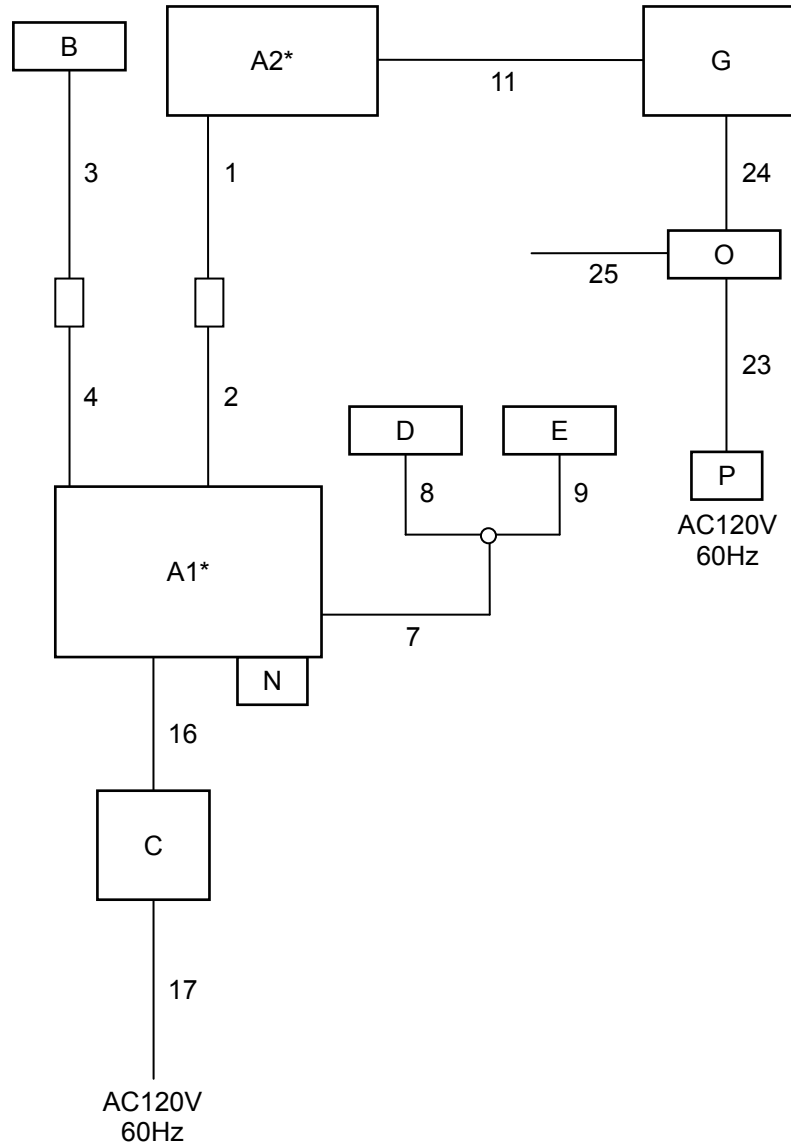

The symbols and numbers assigned to the equipments and cables on this diagram correspond to the ones in Sections 3 to 5.

SECTION 7. OPERATING CONDITION

The test was carried out under the following mode.

7.1 RX mode

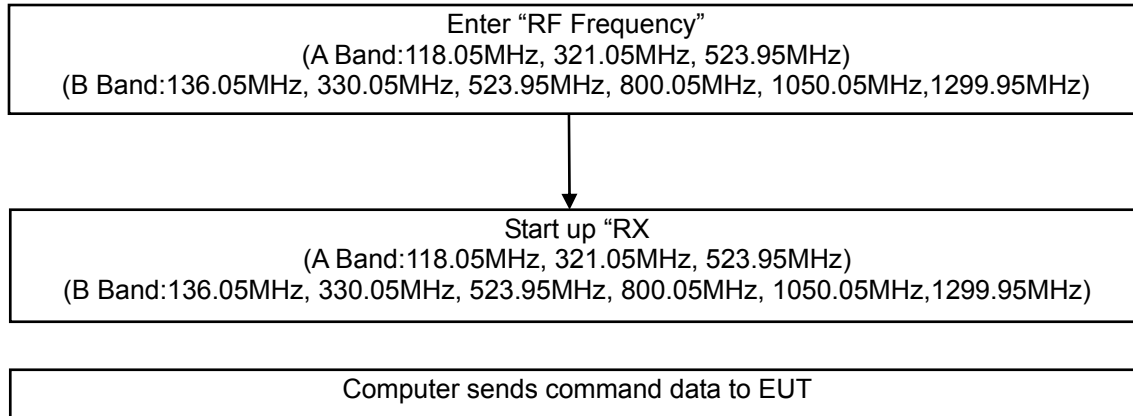

7.2 VFO SCAN mode

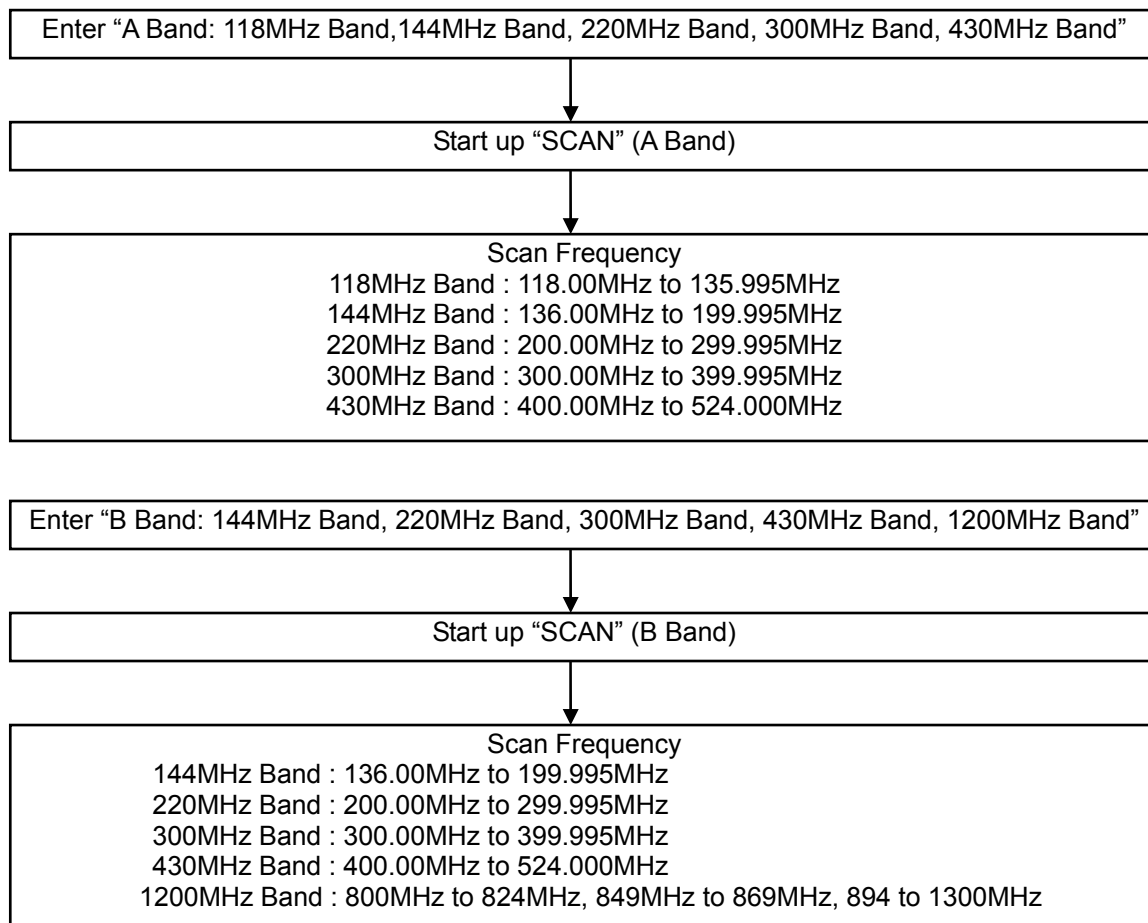

SECTION 8. UNCERTAINTY

Traceability to national standard in SI units is ensured with these values.
 Compliance with the limits in this standard are determined without in consideration of the measurement uncertainty of the measurement instrumentation.

8.1 Emission tests

Radiated disturbance at 3m	$U_{lab} [k = 2]$	U_{cispr}
30 MHz – 1000 MHz	+/- 4.48 dB	5.19 dB
Above 1 GHz CISPR22	+/- 4.30 dB	
ANSI 63.4	+/- 4.84 dB	
Radiated disturbance at 10m		
30 MHz – 1000 MHz	+/- 5.00 dB	5.06 dB
Above 1 GHz	+/- 5.23 dB	
Radiated disturbance at 30m		
	N/A	5.02 dB
Conducted disturbance at mains terminals		
9 kHz – 150 kHz	+/- 3.25 dB	3.97 dB
150 kHz – 30 MHz	+/- 2.86 dB	3.60 dB
Conducted disturbance at telecommunication ports (ISN)		
150 kHz – 30 MHz	+/- 4.92 dB	Nil
Conducted disturbance at telecommunication ports (Capacitive Voltage Probe)		
150 kHz – 30 MHz	+/- 3.85 dB	Nil
Conducted disturbance at telecommunication ports (Current Probe)		
150 kHz – 30 MHz	+/- 3.03 dB	Nil
Conducted disturbance at terminals		
150 kHz – 30 MHz	+/- 2.94 dB	Nil
Disturbance power		
30 MHz – 300 MHz	+/- 3.61 dB	4.45 dB
Conducted power on antenna port		
30 MHz – 1000 MHz	+/- 2.90 dB	Nil
Above 1 GHz	+/- 1.60 dB	
38dB Rejection		
30 kHz – 1300 MHz	+/- 0.56 dB	Nil

The above expanded instrumentation uncertainty, U_{lab} , is estimated in accordance with CISPR 16-4-2.

SECTION 9. EVALUATION OF TEST RESULTS

9.1 Emission tests

9.1.1 Conducted disturbance at mains terminals

Location	Kashima No.3 Test Site
Test Engineer	Koichi Wagatsuma

Frequency Range of Measurements

Required Measurement Frequency Range	Measured Frequency Range
0.15 – 30 MHz	0.15 – 30 MHz

Test Procedure

Item	Document number
Conducted disturbance at mains terminals	RJP-EM001

Setting for the Measuring instruments

Instrument	Detector	Resolution Bandwidth	Video Bandwidth
Receiver	Quasi Peak	10 kHz	N/A
	Average	10 kHz	N/A

< Measurement data correction >

* Conducted disturbance at mains terminals

Emission Level [dBμV] = Meter Reading [dBμV] + Factor [dB]

Margin [dB] = Limit [dBμV] - Emission Level [dBμV]

* Factor = LISN Factor + Cable Loss + ATT

Result of Conducted disturbance at mains terminals
9.1.1.1 RX mode (A Band :118.05MHz/B Band :136.05MHz)

Intertek Japan K.K.
Kashima No.3 Test Site
 Conducted Voltages on Mains Port

APPLICANT : JVC KENWOOD Corporation
 EUT NAME : 144/440MHz FM DUAL BANDER
 MODEL NO. : TM-D710GA
 SERIAL NO. : B3600176
 TEST MODE : RX mode (A Band:118.05MHz/B
 Band:136.05MHz)
 POWER SOURCE : AC 120V, 60Hz
 DATE TESTED : Aug12 2013
 FILE NO. : -
 REGULATION : FCC Part15B Class B
 TEST METHOD : ANSI C63.4-2003
 TEMPERATURE : 25.7 [degC]
 HUMIDITY : 50.0 [%]
 NOTE :

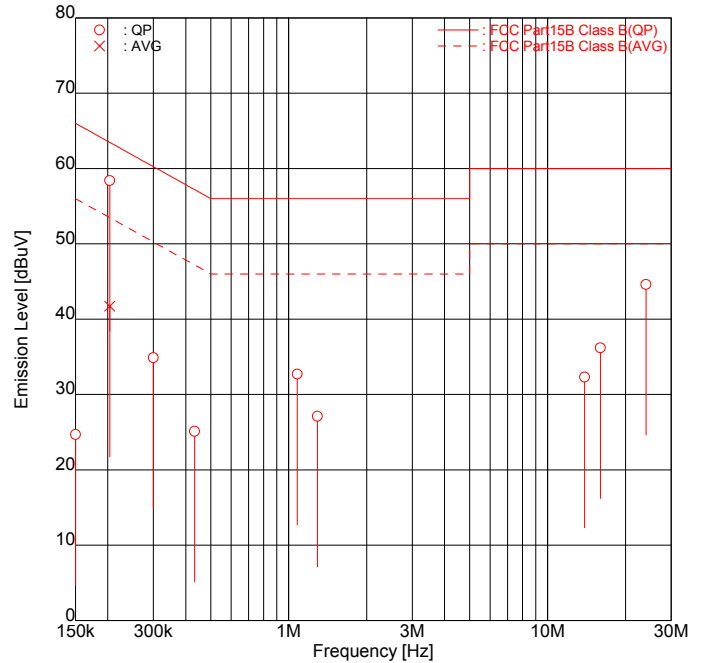

ENGINEER : Koichi Wagatsuma

FREQUENCY [No]	MODE [MHz]	READING [dBuV]		FACTOR [dB]		EMISSION [dBuV]		LIMIT [dBuV]	MARGIN [dB]		
		Line1	Line2	Line1	Line2	Line1	Line2		Line1	Line2	
1	0.1500	QP	14.5	14.4	10.2	10.2	24.7	24.6	66.0	41.3	41.4
2	0.2035	QP	47.9	<u>48.1</u>	10.2	10.3	58.1	<u>58.4</u>	63.5	5.4	<u>5.1</u>
3	0.2035	AVG	31.2	<u>31.4</u>	10.2	10.3	41.4	<u>41.7</u>	53.5	12.1	<u>11.8</u>
4	0.3002	QP	17.0	<u>24.6</u>	10.2	10.3	27.2	<u>34.9</u>	60.2	33.0	<u>25.3</u>
5	0.4331	QP	14.8	14.3	10.3	10.3	25.1	24.6	57.2	32.1	32.6
6	1.0788	QP	<u>22.4</u>	21.9	10.3	10.3	<u>32.7</u>	32.2	56.0	<u>23.3</u>	23.8
7	1.2905	QP	16.8	16.6	10.3	10.3	27.1	26.9	56.0	28.9	29.1
8	13.9015	QP	21.3	21.4	10.9	10.9	32.2	32.3	60.0	27.8	27.7
9	16.0048	QP	25.2	<u>25.3</u>	10.9	10.9	36.1	<u>36.2</u>	60.0	23.9	<u>23.8</u>
10	24.0063	QP	33.1	<u>33.4</u>	10.9	11.2	44.0	<u>44.6</u>	60.0	16.0	<u>15.4</u>

Higher six points are underlined.
 Other frequencies : Below the FCC Part15B Class B limit
 Emission Level = Read + Factor(LISN,Pad,Cable)

9.1.1.2 RX mode (A Band :321.05MHz/B Band :330.05MHz)

Intertek Japan K.K.
Kashima No.3 Test Site
 Conducted Voltages on Mains Port

APPLICANT : JVC KENWOOD Corporation
 EUT NAME : 144/440MHz FM DUAL BANDER
 MODEL NO. : TM-D710GA
 SERIAL NO. : B3600176
 TEST MODE : RX mode (A Band:321.05MHz/B
 Band:330.05MHz)
 POWER SOURCE : AC 120V, 60Hz
 DATE TESTED : Aug 12 2013
 FILE NO. : -
 REGULATION : FCC Part15B Class B
 TEST METHOD : ANSI C63.4-2003
 TEMPERATURE : 25.7 [degC]
 HUMIDITY : 50.0 [%]
 NOTE :

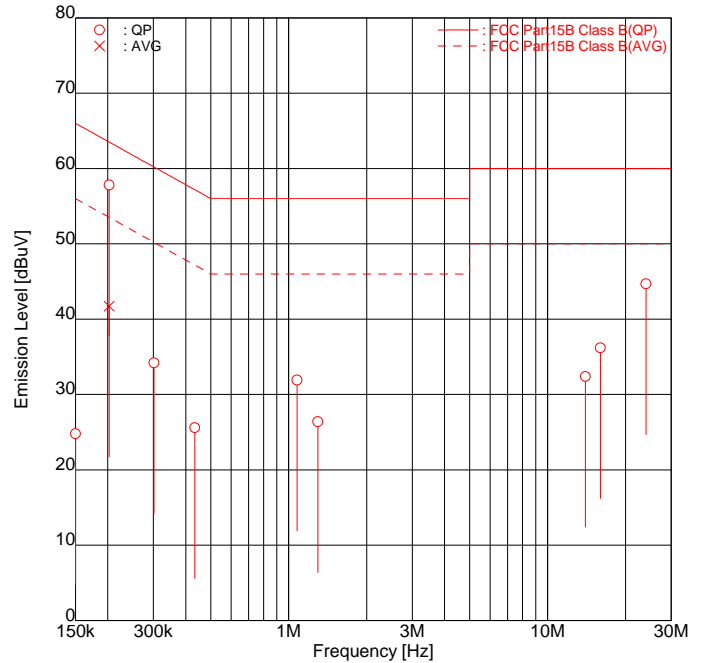

ENGINEER : Koichi Wagatsuma

FREQUENCY [No]	MODE [MHz]		READING [dBuV]		FACTOR [dB]		EMISSION [dBuV]		LIMIT [dBuV]	MARGIN [dB]	
			Line1	Line2	Line1	Line2	Line1	Line2		Line1	Line2
1	0.1500	QP	14.6	14.4	10.2	10.2	24.8	24.6	66.0	41.2	41.4
2	0.2023	QP	47.4	<u>47.5</u>	10.2	10.3	57.6	<u>57.8</u>	63.5	5.9	<u>5.7</u>
3	0.2023	AVG	30.8	<u>31.4</u>	10.2	10.3	41.0	<u>41.7</u>	53.5	12.5	<u>11.8</u>
4	0.3015	QP	16.4	<u>23.9</u>	10.2	10.3	26.6	<u>34.2</u>	60.2	33.6	<u>26.0</u>
5	0.4336	QP	15.3	15.2	10.3	10.3	25.6	25.5	57.2	31.6	31.7
6	1.0766	QP	21.1	<u>21.6</u>	10.3	10.3	31.4	<u>31.9</u>	56.0	24.6	<u>24.1</u>
7	1.2957	QP	16.1	16.1	10.3	10.3	26.4	26.4	56.0	29.6	29.6
8	13.9997	QP	21.5	21.5	10.9	10.9	32.4	32.4	60.0	27.6	27.6
9	16.0049	QP	<u>25.3</u>	25.3	10.9	10.9	<u>36.2</u>	36.2	60.0	<u>23.8</u>	23.8
10	24.0074	QP	33.3	<u>33.5</u>	10.9	11.2	44.2	<u>44.7</u>	60.0	15.8	<u>15.3</u>

Higher six points are underlined.
 Other frequencies : Below the FCC Part15B Class B limit
 Emission Level = Read + Factor(LISN,Pad,Cable)

9.1.1.3 RX mode (A Band :523.95MHz/B Band :523.95MHz)

Intertek Japan K.K.
 Kashima No.3 Test Site
 Conducted Voltages on Mains Port

APPLICANT : JVC KENWOOD Corporation
 EUT NAME : 144/440MHz FM DUAL BANDER
 MODEL NO. : TM-D710GA
 SERIAL NO. : B3600176
 TEST MODE : RX mode (A Band:523.95MHz/B Band:523.95MHz)
 POWER SOURCE : AC 120V, 60Hz
 DATE TESTED : Aug 12 2013
 FILE NO. : -
 REGULATION : FCC Part15B Class B
 TEST METHOD : ANSI C63.4-2003
 TEMPERATURE : 25.7 [degC]
 HUMIDITY : 50.0 [%]
 NOTE :

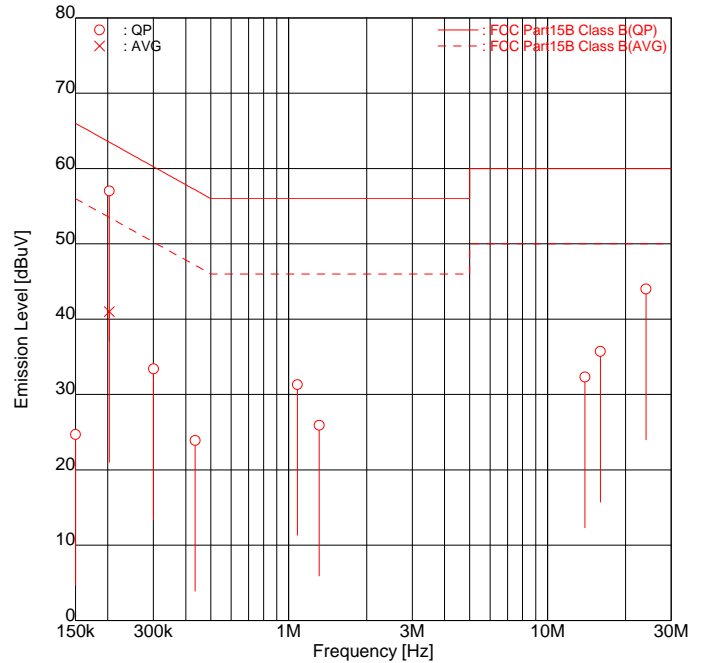

ENGINEER : Koichi Wagatsuma

FREQUENCY [No]	MODE [MHz]		READING [dBuV]		FACTOR [dB]		EMISSION [dBuV]		LIMIT [dBuV]	MARGIN [dB]	
			Line1	Line2	Line1	Line2	Line1	Line2		Line1	Line2
1	0.1500	QP	14.5	14.4	10.2	10.2	24.7	24.6	66.0	41.3	41.4
2	0.2028	QP	46.6	<u>46.7</u>	10.2	10.3	56.8	<u>57.0</u>	63.5	6.7	6.5
3	0.2028	AVG	30.0	<u>30.7</u>	10.2	10.3	40.2	<u>41.0</u>	53.5	13.3	<u>12.5</u>
4	0.3006	QP	15.3	<u>23.1</u>	10.2	10.3	25.5	<u>33.4</u>	60.2	34.7	<u>26.8</u>
5	0.4353	QP	13.5	13.6	10.3	10.3	23.8	23.9	57.2	33.4	33.3
6	1.0807	QP	20.9	<u>21.0</u>	10.3	10.3	31.2	<u>31.3</u>	56.0	24.8	<u>24.7</u>
7	1.3110	QP	15.4	15.6	10.3	10.3	25.7	25.9	56.0	30.3	30.1
8	13.9444	QP	21.4	21.3	10.9	10.9	32.3	32.2	60.0	27.7	27.8
9	16.0049	QP	<u>24.8</u>	24.7	10.9	10.9	<u>35.7</u>	35.6	60.0	<u>24.3</u>	24.4
10	24.0071	QP	32.9	<u>32.8</u>	10.9	11.2	43.8	<u>44.0</u>	60.0	16.2	<u>16.0</u>

Higher six points are underlined.
 Other frequencies : Below the FCC Part15B Class B limit
 Emission Level = Read + Factor(LISN,Pad,Cable)

9.1.1.4 RX mode (A Band :118.05MHz/B Band :800.05MHz)

Intertek Japan K.K.
Kashima No.3 Test Site
 Conducted Voltages on Mains Port

APPLICANT : JVC KENWOOD Corporation
 EUT NAME : 144/440MHz FM DUAL BANDER
 MODEL NO. : TM-D710GA
 SERIAL NO. : B3600176
 TEST MODE : RX mode (A Band:118.05MHz/B
 Band:800.05MHz)
 POWER SOURCE : AC 120V, 60Hz
 DATE TESTED : Aug 12 2013
 FILE NO. : -
 REGULATION : FCC Part15B Class B
 TEST METHOD : ANSI C63.4-2003
 TEMPERATURE : 25.7 [degC]
 HUMIDITY : 50.0 [%]
 NOTE :

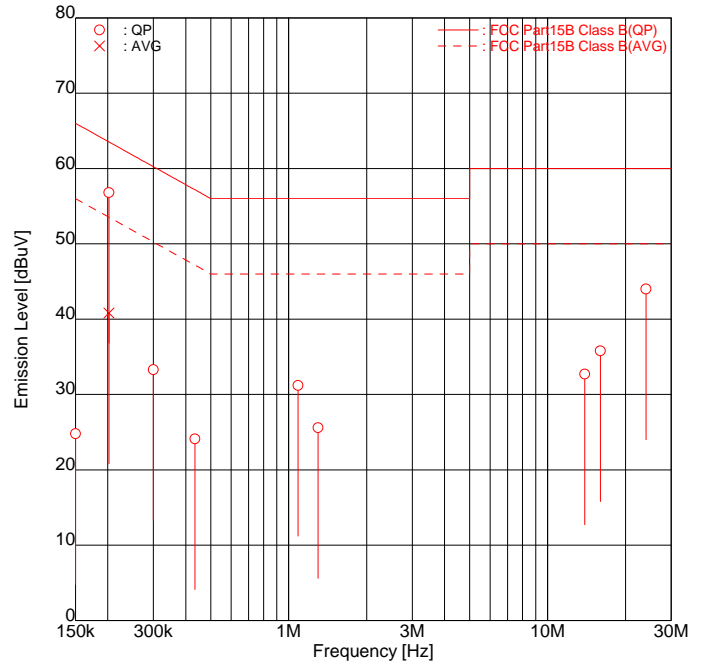

ENGINEER : Koichi Wagatsuma

FREQUENCY [No]	MODE [MHz]		READING [dBuV]		FACTOR [dB]		EMISSION [dBuV]		LIMIT [dBuV]	MARGIN [dB]	
			Line1	Line2	Line1	Line2	Line1	Line2		Line1	Line2
1	0.1500	QP	14.5	14.6	10.2	10.2	24.7	24.8	66.0	41.3	41.2
2	0.2022	QP	46.2	<u>46.5</u>	10.2	10.3	56.4	<u>56.8</u>	63.5	7.1	6.7
3	0.2022	AVG	30.0	<u>30.5</u>	10.2	10.3	40.2	<u>40.8</u>	53.5	13.3	<u>12.7</u>
4	0.2998	QP	14.9	<u>23.0</u>	10.2	10.3	25.1	<u>33.3</u>	60.2	35.1	<u>26.9</u>
5	0.4347	QP	13.7	13.8	10.3	10.3	24.0	24.1	57.2	33.2	33.1
6	1.0869	QP	<u>20.9</u>	20.9	10.3	10.3	<u>31.2</u>	31.2	56.0	<u>24.8</u>	24.8
7	1.2990	QP	15.3	15.3	10.3	10.3	25.6	25.6	56.0	30.4	30.4
8	13.9286	QP	21.6	21.8	10.9	10.9	32.5	32.7	60.0	27.5	27.3
9	16.0048	QP	<u>24.9</u>	24.9	10.9	10.9	<u>35.8</u>	35.8	60.0	<u>24.2</u>	24.2
10	24.0062	QP	33.0	<u>32.8</u>	10.9	11.2	43.9	<u>44.0</u>	60.0	16.1	<u>16.0</u>

 Higher six points are underlined.
 Other frequencies : Below the FCC Part15B Class B limit
 Emission Level = Read + Factor(LISN,Pad,Cable)

9.1.1.5 RX mode (A Band :321.05MHz/B Band :1050.05MHz)

Intertek Japan K.K.
Kashima No.3 Test Site
 Conducted Voltages on Mains Port

APPLICANT : JVC KENWOOD Corporation
 EUT NAME : 144/440MHz FM DUAL BANDER
 MODEL NO. : TM-D710GA
 SERIAL NO. : B3600176
 TEST MODE : RX mode (A Band:321.05MHz/B
 Band:1050.05MHz)
 POWER SOURCE : AC 120V, 60Hz
 DATE TESTED : Aug 12 2013
 FILE NO. : -
 REGULATION : FCC Part15B Class B
 TEST METHOD : ANSI C63.4-2003
 TEMPERATURE : 25.7 [degC]
 HUMIDITY : 50.0 [%]
 NOTE :

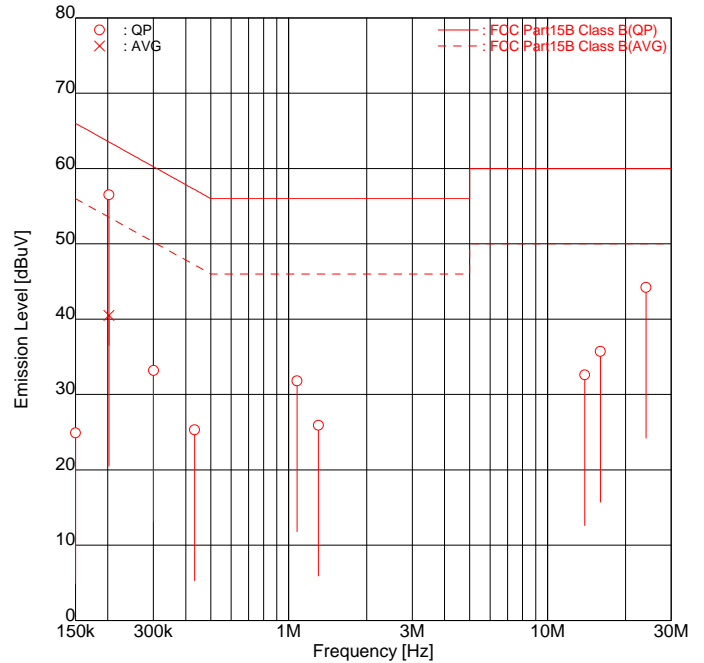

ENGINEER : Koichi Wagatsuma

FREQUENCY [No]	MODE [MHz]		READING [dBuV]		FACTOR [dB]		EMISSION [dBuV]		LIMIT [dBuV]	MARGIN [dB]	
			Line1	Line2	Line1	Line2	Line1	Line2		Line1	Line2
1	0.1500	QP	14.6	14.7	10.2	10.2	24.8	24.9	66.0	41.2	41.1
2	0.2021	QP	46.0	<u>46.2</u>	10.2	10.3	56.2	<u>56.5</u>	63.5	7.3	7.0
3	0.2021	AVG	29.8	<u>30.2</u>	10.2	10.3	40.0	<u>40.5</u>	53.5	13.5	<u>13.0</u>
4	0.3007	QP	14.7	<u>22.9</u>	10.2	10.3	24.9	<u>33.2</u>	60.2	35.3	<u>27.0</u>
5	0.4332	QP	15.0	14.7	10.3	10.3	25.3	25.0	57.2	31.9	32.2
6	1.0775	QP	<u>21.5</u>	21.3	10.3	10.3	<u>31.8</u>	31.6	56.0	<u>24.2</u>	24.4
7	1.3023	QP	15.4	15.6	10.3	10.3	25.7	25.9	56.0	30.3	30.1
8	13.9080	QP	21.7	21.7	10.9	10.9	32.6	32.6	60.0	27.4	27.4
9	16.0025	QP	<u>24.8</u>	24.7	10.9	10.9	<u>35.7</u>	35.6	60.0	<u>24.3</u>	24.4
10	24.0069	QP	32.8	<u>33.0</u>	10.9	11.2	43.7	<u>44.2</u>	60.0	16.3	<u>15.8</u>

Higher six points are underlined.
 Other frequencies : Below the FCC Part15B Class B limit
 Emission Level = Read + Factor(LISN,Pad,Cable)

9.1.1.6 RX mode (A Band :523.95MHz/B Band :1299.95MHz)

Intertek Japan K.K.
Kashima No.3 Test Site
 Conducted Voltages on Mains Port

APPLICANT : JVC KENWOOD Corporation
 EUT NAME : 144/440MHz FM DUAL BANDER
 MODEL NO. : TM-D710GA
 SERIAL NO. : B3600176
 TEST MODE : RX mode (A Band:523.95MHz/B
 Band:1299.95MHz)
 POWER SOURCE : AC 120V, 60Hz
 DATE TESTED : Aug 12 2013
 FILE NO. : -
 REGULATION : FCC Part15B Class B
 TEST METHOD : ANSI C63.4-2003
 TEMPERATURE : 25.7 [degC]
 HUMIDITY : 50.0 [%]
 NOTE :

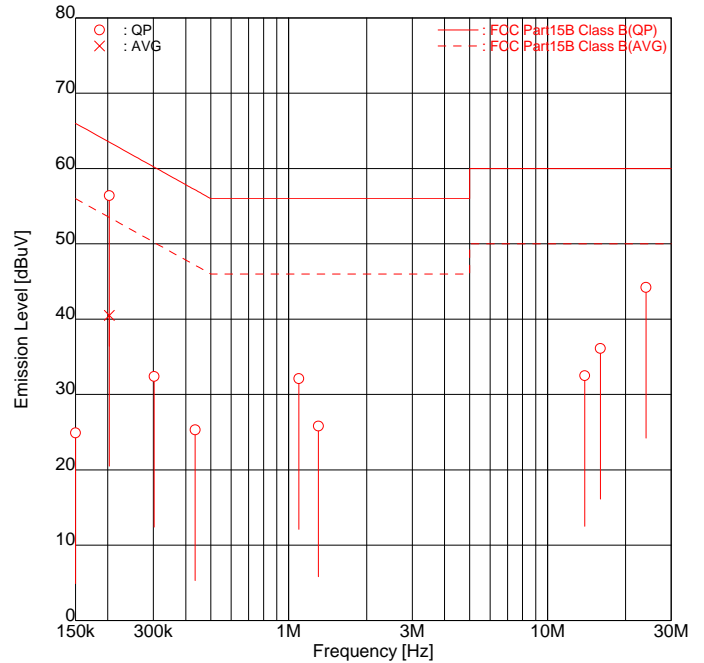

ENGINEER : Koichi Wagatsuma

FREQUENCY [No]	MODE [MHz]		READING [dBuV]		FACTOR [dB]		EMISSION [dBuV]		LIMIT [dBuV]	MARGIN [dB]	
			Line1	Line2	Line1	Line2	Line1	Line2		Line1	Line2
1	0.1500	QP	14.5	14.7	10.2	10.2	24.7	24.9	66.0	41.3	41.1
2	0.2028	QP	46.0	<u>46.1</u>	10.2	10.3	56.2	<u>56.4</u>	63.5	7.3	<u>7.1</u>
3	0.2028	AVG	29.9	<u>30.2</u>	10.2	10.3	40.1	<u>40.5</u>	53.5	13.4	<u>13.0</u>
4	0.3021	QP	14.8	22.1	10.2	10.3	25.0	32.4	60.2	35.2	27.8
5	0.4353	QP	15.0	14.2	10.3	10.3	25.3	24.5	57.2	31.9	32.7
6	1.0934	QP	<u>21.8</u>	21.6	10.3	10.3	<u>32.1</u>	31.9	56.0	<u>23.9</u>	24.1
7	1.3022	QP	15.3	15.5	10.3	10.3	25.6	25.8	56.0	30.4	30.2
8	13.9072	QP	<u>21.6</u>	21.6	10.9	10.9	<u>32.5</u>	32.5	60.0	<u>27.5</u>	27.5
9	16.0049	QP	<u>25.2</u>	25.0	10.9	10.9	<u>36.1</u>	35.9	60.0	<u>23.9</u>	24.1
10	24.0060	QP	33.0	<u>33.0</u>	10.9	11.2	43.9	<u>44.2</u>	60.0	16.1	<u>15.8</u>

Higher six points are underlined.
 Other frequencies : Below the FCC Part15B Class B limit
 Emission Level = Read + Factor(LISN,Pad,Cable)

9.1.2 Field Strength Emission and Spurious Emission (Radiated disturbance)

Location	Kashima No.12 Test Site
Test Engineer	Koichi Wagatsuma and Katsuya Uchida

Frequency Range of Measurements

Field Strength Emission

Operating mode	Required Frequency Range	Measured Frequency Range
RX mode (A Band :118.05MHz/B Band :136.05MHz) RX mode (A Band :321.05MHz/B Band :330.05MHz) RX mode (A Band :523.95MHz/B Band :523.95MHz) RX mode (A Band :118.05MHz/B Band :800.05MHz) RX mode (A Band :321.05MHz/B Band :1050.05MHz) RX mode (A Band :523.95MHz/B Band :1299.95MHz) VFO SCAN mode(A Band :144MHz Band/B Band : 144MHz Band) VFO SCAN mode(A Band :220MHz Band/B Band : 220MHz Band) VFO SCAN mode(A Band :300MHz Band/B Band : 300MHz Band) VFO SCAN mode(A Band :430MHz Band/B Band : 430MHz Band) VFO SCAN mode(A Band :118MHz Band/B Band : 1200MHz Band)	30 – 16000 MHz	30 – 16000 MHz

Test Procedure

Item	Document number
Radiated disturbance	RJP-EM003

Setting for the Measuring instruments

Frequency [MHz]	Instrument	Detector	Resolution Bandwidth	Video Bandwidth
30 – 1000	Receiver	Quasi Peak	120 kHz	N/A
Above 1000	Spectrum Analyzer	Peak	1 MHz	1 MHz
		Average	1 MHz	10 Hz

< Measurement data correction >

* Radiated disturbance

Emission Level [dB μ V/m] = Meter Reading [dB μ V] + Factor [dB/m]

Margin [dB] = Limit [dB μ V/m] - Emission Level [dB μ V/m]

* Factor = Antenna Factor + Cable Loss - Amplifier Gain + ATT
 (– Distance Conversion Factor)

Specification of Radiated disturbance

Operating Condition	Frequency Range	Measurement distance	Antenna height
RX mode (A Band :118.05MHz/B Band :136.05MHz) RX mode (A Band :321.05MHz/B Band :330.05MHz) RX mode (A Band :523.95MHz/B Band :523.95MHz) RX mode (A Band :118.05MHz/B Band :800.05MHz) RX mode (A Band :321.05MHz/B Band :1050.05MHz) RX mode (A Band :523.95MHz/B Band :1299.95MHz) VFO SCAN mode(A Band :144MHz Band/B Band : 144MHz Band) VFO SCAN mode(A Band :220MHz Band/B Band : 220MHz Band) VFO SCAN mode(A Band :300MHz Band/B Band : 300MHz Band) VFO SCAN mode(A Band :430MHz Band/B Band : 430MHz Band) VFO SCAN mode(A Band :118MHz Band/B Band : 1200MHz Band)	30 MHz – 16000 MHz	3.0 m	Scanned 1 to 4 m

Result of Radiated disturbances

**9.1.2.1 RX mode (A Band :118.05MHz/B Band :136.05MHz)
 30 - 1000MHz**

Intertek Japan K.K.
Kashima No.12 Test Site
 Radiated Electric Field

APPLICANT : JVC KENWOOD Corporation
 EUT NAME : 144/440MHz FM DUAL BANDER
 MODEL NO. : TM-D710GA
 SERIAL NO. : B3600176
 TEST MODE : RX mode (A Band:118.05MHz/B Band:
 136.05MHz)
 POWER SOURCE : DC 13.8V (AC120V 60Hz)
 DATE TESTED : Aug 05 2013
 FILE NO. : -
 REGULATION : FCC Part15B Class B
 TEST METHOD : ANSI C63.4-2003
 DISTANCE : 3.00 [m]
 TEMPERATURE : 24.2 [degC]
 HUMIDITY : 60.0 [%]
 NOTE :

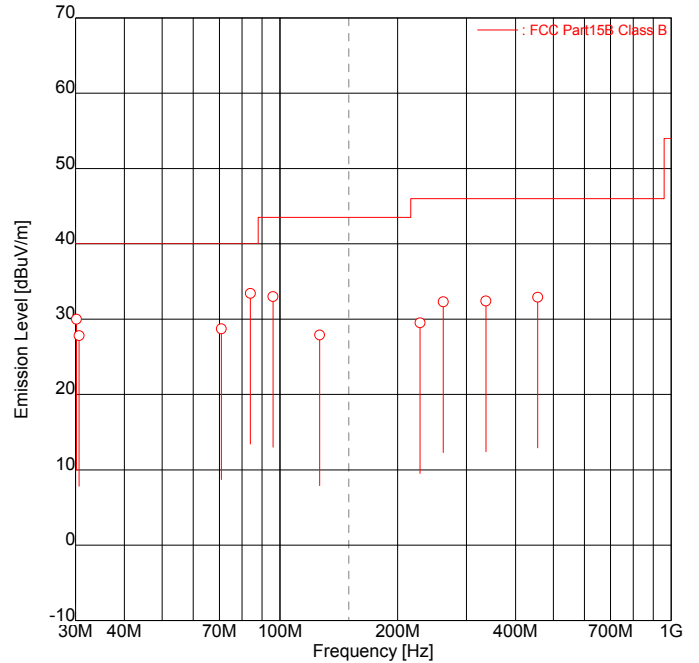

ENGINEER : Koichi Wagatsuma

FREQUENCY [No]	FREQUENCY [MHz]	READING [dBuV]		FACTOR [dB/m]		EMISSION [dBuV/m]		LIMIT [dBuV/m]	MARGIN [dB]	
		Hori	Vert	Hori	Vert	Hori	Vert		Hori	Vert
1	30.20	-	<u>33.4</u>	-3.4	-3.4	-	<u>30.0</u>	40.0	-	<u>10.0</u>
2	30.65	-	<u>31.1</u>	-3.3	-3.3	-	<u>27.8</u>	40.0	-	<u>12.2</u>
3	70.88	<u>31.7</u>	-	-3.0	-3.0	<u>28.7</u>	-	40.0	<u>11.3</u>	-
4	84.05	<u>37.5</u>	<u>39.2</u>	-5.8	-5.8	<u>31.7</u>	<u>33.4</u>	40.0	8.3	<u>6.6</u>
5	96.02	<u>37.2</u>	<u>39.0</u>	-6.0	-6.0	<u>31.2</u>	<u>33.0</u>	43.5	12.3	<u>10.5</u>
6	126.35	-	30.4	-2.5	-2.5	-	27.9	43.5	-	15.6
7	228.12	-	31.6	-2.1	-2.1	-	29.5	46.0	-	16.5
8	261.73	32.8	-	-0.5	-0.5	32.3	-	46.0	13.7	-
9	336.18	30.1	-	2.3	2.3	32.4	-	46.0	13.6	-
10	456.25	<u>27.0</u>	-	5.9	5.9	<u>32.9</u>	-	46.0	<u>13.1</u>	-

Higher six points are underlined.
 Other frequencies : Below the FCC Part15B Class B limit
 Emission Level = Read + Factor(Antenna,Antenna Pad,Cable,Preamp)
 ANT. : Used antenna(BBA = Broadband antenna, DIP = Dipole antenna)

1000 - 16000 MHz

Intertek Japan K.K.
Kashima No.12 Test Site
Radiated Electric Field

APPLICANT : JVC KENWOOD Corporation
 EUT NAME : 144/440MHz FM DUAL BANDER
 MODEL NO. : TM-D710GA
 SERIAL NO. : B3600176
 TEST MODE : RX mode (A Band:118.05MHz/B Band:
 136.05MHz)
 POWER SOURCE : DC 13.8V (AC120V 60Hz)
 DATE TESTED : Aug 06 2013
 FILE NO. : -
 REGULATION : FCC Part15B Class B
 TEST METHOD : ANSI C63.4-2003
 DISTANCE : 3.00 [m]
 TEMPERATURE : 24.5 [degC]
 HUMIDITY : 64.0 [%]
 NOTE :

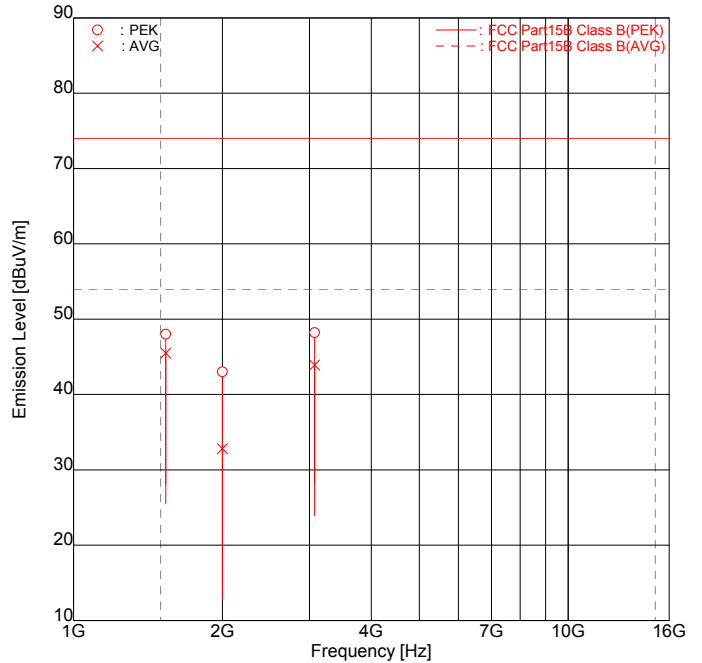

ENGINEER : Koichi Wagatsuma

FREQUENCY [No]	MODE [MHz]		READING [dBuV]		FACTOR [dB/m]		EMISSION [dBuV/m]		LIMIT [dBuV/m]	MARGIN [dB]	
			Hori	Vert	Hori	Vert	Hori	Vert		Hori	Vert
1	1536.85	PEK	50.5	<u>52.3</u>	-4.3	-4.3	46.2	<u>48.0</u>	74.0	27.8	<u>26.0</u>
2	1536.85	AVG	46.8	<u>49.8</u>	-4.3	-4.3	42.5	<u>45.5</u>	54.0	11.5	<u>8.5</u>
3	2000.05	PEK	<u>45.1</u>	44.6	-2.1	-2.1	<u>43.0</u>	42.5	74.0	<u>31.0</u>	31.5
4	2000.05	AVG	<u>34.9</u>	34.5	-2.1	-2.1	<u>32.8</u>	32.4	54.0	<u>21.2</u>	21.6
5	3073.63	PEK	44.5	<u>47.5</u>	0.7	0.7	45.2	<u>48.2</u>	74.0	28.8	<u>25.8</u>
6	3073.63	AVG	37.8	<u>43.2</u>	0.7	0.7	38.5	<u>43.9</u>	54.0	15.5	<u>10.1</u>

Higher six points are underlined.
 Other frequencies : Below the FCC Part15B Class B limit
 Emission Level = Read + Factor(Antenna,Antenna Pad,Cable,Preamp)
 ANT. : Used antenna(BBA = Broadband antenna, DIP = Dipole antenna)

**9.1.2.2 RX mode (A Band :321.05MHz/B Band :330.05MHz)
 30 - 1000MHz**

Intertek Japan K.K.
Kashima No.12 Test Site
 Radiated Electric Field

APPLICANT : JVC KENWOOD Corporation
 EUT NAME : 144/440MHz FM DUAL BANDER
 MODEL NO. : TM-D710GA
 SERIAL NO. : B3600176
 TEST MODE : RX mode (A Band:321.05MHz/B Band:
 330.05MHz)
 POWER SOURCE : DC 13.8V (AC120V 60Hz)
 DATE TESTED : Aug 05 2013
 FILE NO. : -
 REGULATION : FCC Part15B Class B
 TEST METHOD : ANSI C63.4-2003
 DISTANCE : 3.00 [m]
 TEMPERATURE : 24.2 [degC]
 HUMIDITY : 60.0 [%]
 NOTE :

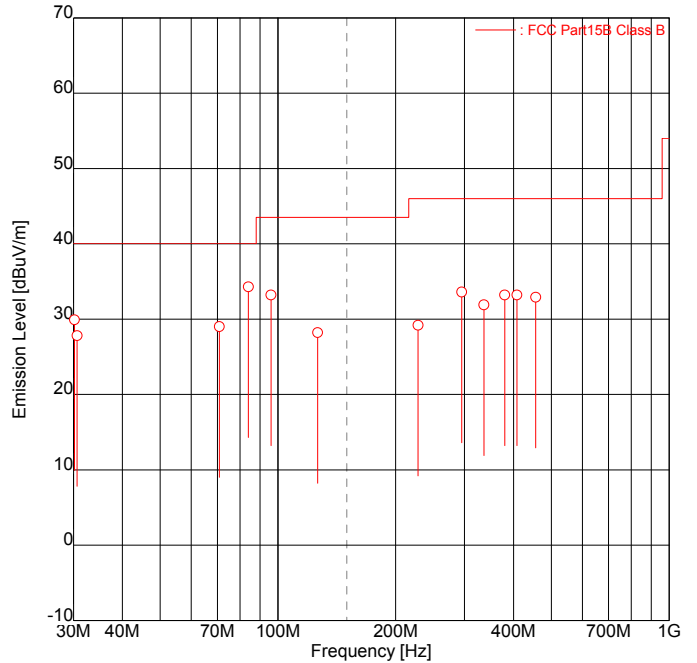

ENGINEER : Koichi Wagatsuma

FREQUENCY [No]	FREQUENCY [MHz]	READING [dBuV]		FACTOR [dB/m]		EMISSION [dBuV/m]		LIMIT [dBuV/m]	MARGIN [dB]	
		Hori	Vert	Hori	Vert	Hori	Vert		Hori	Vert
1	30.20	-	<u>33.3</u>	-3.4	-3.4	-	<u>29.9</u>	40.0	-	<u>10.1</u>
2	30.65	-	<u>31.1</u>	-3.3	-3.3	-	<u>27.8</u>	40.0	-	<u>12.2</u>
3	70.88	<u>32.0</u>	-	-3.0	-3.0	<u>29.0</u>	-	40.0	<u>11.0</u>	-
4	84.05	37.5	<u>40.1</u>	-5.8	-5.8	31.7	<u>34.3</u>	40.0	8.3	<u>5.7</u>
5	96.02	36.0	<u>39.2</u>	-6.0	-6.0	30.0	<u>33.2</u>	43.5	13.5	<u>10.3</u>
6	126.35	-	30.7	-2.5	-2.5	-	28.2	43.5	-	15.3
7	228.12	-	31.3	-2.1	-2.1	-	29.2	46.0	-	16.8
8	294.90	<u>32.6</u>	-	1.0	1.0	<u>33.6</u>	-	46.0	<u>12.4</u>	-
9	336.20	<u>29.6</u>	-	2.3	2.3	<u>31.9</u>	-	46.0	<u>14.1</u>	-
10	380.01	-	29.6	3.6	3.6	-	33.2	46.0	-	12.8
11	408.23	28.7	-	4.5	4.5	33.2	-	46.0	12.8	-
12	456.25	27.0	-	5.9	5.9	32.9	-	46.0	13.1	-

Higher six points are underlined.
 Other frequencies : Below the FCC Part15B Class B limit
 Emission Level = Read + Factor(Antenna,Antenna Pad,Cable,Preamp)
 ANT. : Used antenna(BBA = Broadband antenna, DIP = Dipole antenna)

1000 - 16000 MHz

Intertek Japan K.K.
Kashima No.12 Test Site
Radiated Electric Field

APPLICANT : JVC KENWOOD Corporation
 EUT NAME : 144/440MHz FM DUAL BANDER
 MODEL NO. : TM-D710GA
 SERIAL NO. : B3600176
 TEST MODE : RX mode (A Band:321.05MHz/B Band:
 330.05MHz)
 POWER SOURCE : DC 13.8V (AC120V 60Hz)
 DATE TESTED : Aug 06 2013
 FILE NO. : -
 REGULATION : FCC Part15B Class B
 TEST METHOD : ANSI C63.4-2003
 DISTANCE : 3.00 [m]
 TEMPERATURE : 24.5 [degC]
 HUMIDITY : 64.0 [%]
 NOTE :

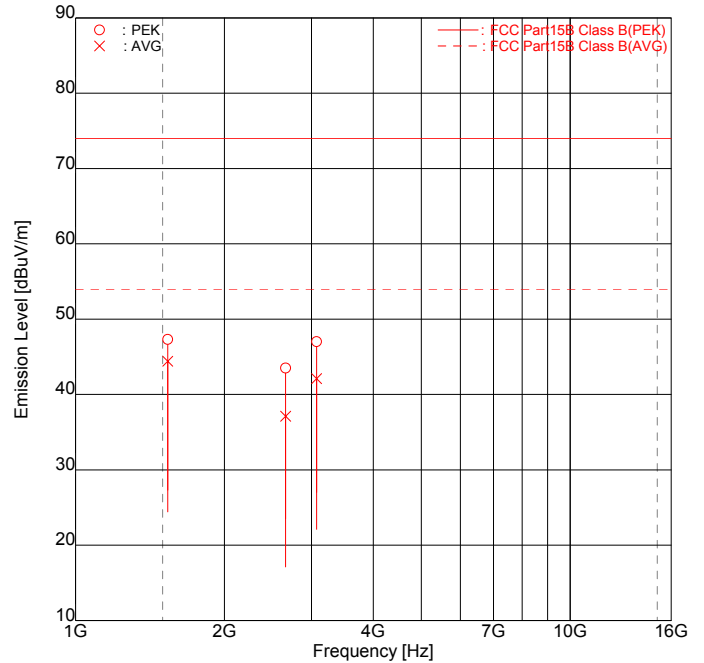

ENGINEER : Koichi Wagatsuma

FREQUENCY [No]	MODE [MHz]		READING [dBuV]		FACTOR [dB/m]		EMISSION [dBuV/m]		LIMIT [dBuV/m]	MARGIN [dB]	
			Hori	Vert	Hori	Vert	Hori	Vert		Hori	Vert
1	1536.85	PEK	49.9	<u>51.6</u>	-4.3	-4.3	45.6	<u>47.3</u>	74.0	28.4	<u>26.7</u>
2	1536.85	AVG	46.7	<u>48.7</u>	-4.3	-4.3	42.4	<u>44.4</u>	54.0	11.6	<u>9.6</u>
3	2660.00	PEK	-	<u>44.3</u>	-0.8	-0.8	-	<u>43.5</u>	74.0	-	<u>30.5</u>
4	2660.00	AVG	-	<u>37.9</u>	-0.8	-0.8	-	<u>37.1</u>	54.0	-	<u>16.9</u>
5	3073.63	PEK	44.6	<u>46.3</u>	0.7	0.7	45.3	<u>47.0</u>	74.0	28.7	<u>27.0</u>
6	3073.63	AVG	37.8	<u>41.4</u>	0.7	0.7	38.5	<u>42.1</u>	54.0	15.5	<u>11.9</u>

Higher six points are underlined.
 Other frequencies : Below the FCC Part15B Class B limit
 Emission Level = Read + Factor(Antenna,Antenna Pad,Cable,Preamp)
 ANT. : Used antenna(BBA = Broadband antenna, DIP = Dipole antenna)

**9.1.2.3 RX mode (A Band :523.95MHz/B Band :523.95MHz)
 30 - 1000MHz**

Intertek Japan K.K.
Kashima No.12 Test Site
 Radiated Electric Field

APPLICANT : JVC KENWOOD Corporation
 EUT NAME : 144/440MHz FM DUAL BANDER
 MODEL NO. : TM-D710GA
 SERIAL NO. : B3600176
 TEST MODE : RX mode (A Band:523.95MHz/B Band:
 523.95MHz)
 POWER SOURCE : DC 13.8V (AC120V 60Hz)
 DATE TESTED : Aug 05 2013
 FILE NO. : -
 REGULATION : FCC Part15B Class B
 TEST METHOD : ANSI C63.4-2003
 DISTANCE : 3.00 [m]
 TEMPERATURE : 24.2 [degC]
 HUMIDITY : 60.0 [%]
 NOTE :

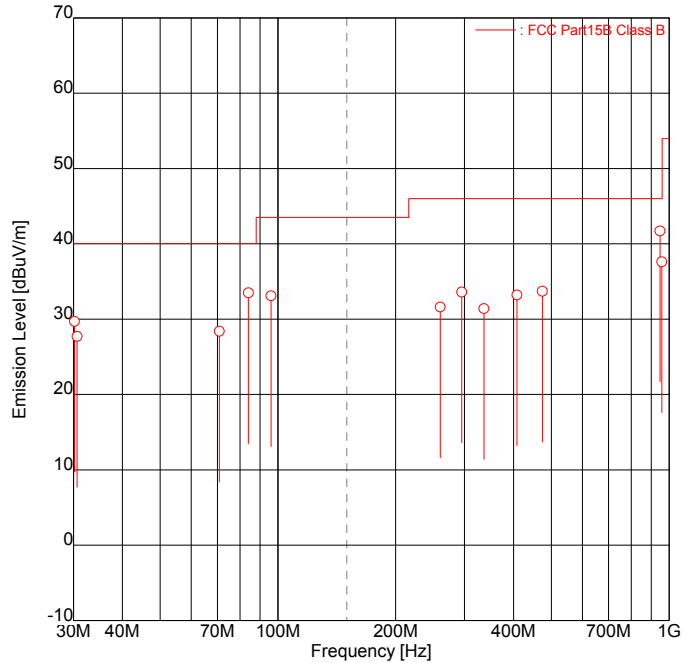

ENGINEER : Koichi Wagatsuma

FREQUENCY [No]	FREQUENCY [MHz]	READING [dBuV]		FACTOR [dB/m]		EMISSION [dBuV/m]		LIMIT [dBuV/m]	MARGIN [dB]	
		Hori	Vert	Hori	Vert	Hori	Vert		Hori	Vert
1	30.20	-	<u>33.1</u>	-3.4	-3.4	-	<u>29.7</u>	40.0	-	<u>10.3</u>
2	30.65	-	31.0	-3.3	-3.3	-	27.7	40.0	-	12.3
3	70.88	<u>31.4</u>	-	-3.0	-3.0	<u>28.4</u>	-	40.0	<u>11.6</u>	-
4	84.05	36.6	<u>39.3</u>	-5.8	-5.8	30.8	<u>33.5</u>	40.0	9.2	<u>6.5</u>
5	96.02	37.3	<u>39.1</u>	-6.0	-6.0	31.3	<u>33.1</u>	43.5	12.2	<u>10.4</u>
6	259.90	32.2	-	-0.6	-0.6	31.6	-	46.0	14.4	-
7	294.90	32.6	-	1.0	1.0	33.6	-	46.0	12.4	-
8	336.20	29.1	-	2.3	2.3	31.4	-	46.0	14.6	-
9	408.23	28.7	-	4.5	4.5	33.2	-	46.0	12.8	-
10	474.01	27.4	26.9	6.3	6.3	33.7	33.2	46.0	12.3	12.8
11	948.01	-	<u>25.2</u>	16.5	16.5	-	<u>41.7</u>	46.0	-	<u>4.3</u>
12	957.82	<u>21.0</u>	19.6	16.6	16.6	<u>37.6</u>	36.2	46.0	<u>8.4</u>	9.8

Higher six points are underlined.
 Other frequencies : Below the FCC Part15B Class B limit
 Emission Level = Read + Factor(Antenna,Antenna Pad,Cable,Preamp)
 ANT. : Used antenna(BBA = Broadband antenna, DIP = Dipole antenna)

1000 - 16000 MHz

Intertek Japan K.K.
Kashima No.12 Test Site
Radiated Electric Field

APPLICANT : JVC KENWOOD Corporation
 EUT NAME : 144/440MHz FM DUAL BANDER
 MODEL NO. : TM-D710GA
 SERIAL NO. : B3600176
 TEST MODE : RX mode (A Band:523.95MHz/B Band:
 523.95MHz)
 POWER SOURCE : DC 13.8V (AC120V 60Hz)
 DATE TESTED : Aug 06 2013
 FILE NO. : -
 REGULATION : FCC Part15B Class B
 TEST METHOD : ANSI C63.4-2003
 DISTANCE : 3.00 [m]
 TEMPERATURE : 24.5 [degC]
 HUMIDITY : 64.0 [%]
 NOTE :

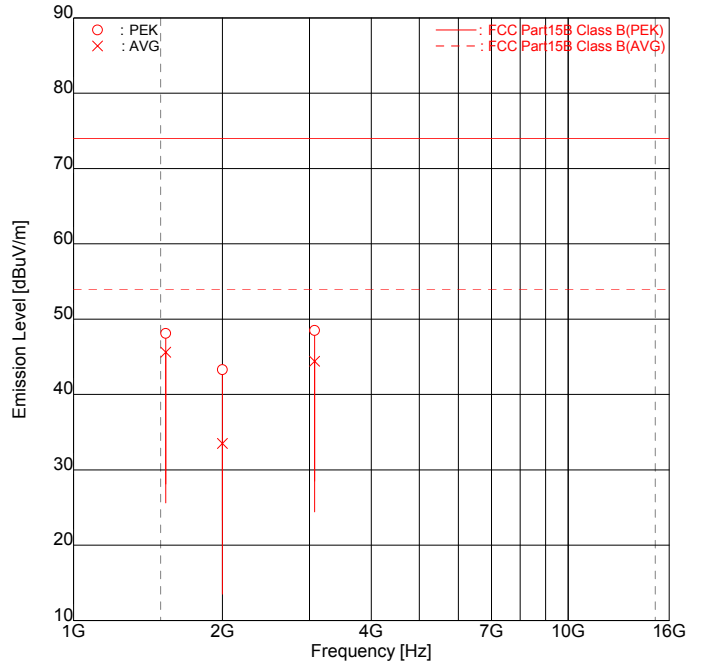

ENGINEER : Koichi Wagatsuma

FREQUENCY [No]	MODE [MHz]		READING [dBuV]		FACTOR [dB/m]		EMISSION [dBuV/m]		LIMIT [dBuV/m]	MARGIN [dB]	
			Hori	Vert	Hori	Vert	Hori	Vert		Hori	Vert
1	1536.85	PEK	50.5	<u>52.4</u>	-4.3	-4.3	46.2	<u>48.1</u>	74.0	27.8	<u>25.9</u>
2	1536.85	AVG	47.0	<u>49.9</u>	-4.3	-4.3	42.7	<u>45.6</u>	54.0	11.3	<u>8.4</u>
3	2000.05	PEK	43.5	<u>45.4</u>	-2.1	-2.1	41.4	<u>43.3</u>	74.0	32.6	<u>30.7</u>
4	2000.05	AVG	34.6	<u>35.6</u>	-2.1	-2.1	32.5	<u>33.5</u>	54.0	21.5	<u>20.5</u>
5	3073.63	PEK	44.7	<u>47.8</u>	0.7	0.7	45.4	<u>48.5</u>	74.0	28.6	<u>25.5</u>
6	3073.63	AVG	38.2	<u>43.7</u>	0.7	0.7	38.9	<u>44.4</u>	54.0	15.1	<u>9.6</u>

Higher six points are underlined.
 Other frequencies : Below the FCC Part15B Class B limit
 Emission Level = Read + Factor(Antenna,Antenna Pad,Cable,Preamp)
 ANT. : Used antenna(BBA = Broadband antenna, DIP = Dipole antenna)

**9.1.2.4 RX mode (A Band :118.05MHz/B Band :800.05MHz)
 30 - 1000MHz**

Intertek Japan K.K.
Kashima No.12 Test Site
 Radiated Electric Field

APPLICANT : JVC KENWOOD Corporation
 EUT NAME : 144/440MHz FM DUAL BANDER
 MODEL NO. : TM-D710GA
 SERIAL NO. : B3600176
 TEST MODE : RX mode (A Band:118.05MHz/B Band:
 800.05MHz)
 POWER SOURCE : DC 13.8V (AC120V 60Hz)
 DATE TESTED : Aug 05 2013
 FILE NO. : -
 REGULATION : FCC Part15B Class B
 TEST METHOD : ANSI C63.4-2003
 DISTANCE : 3.00 [m]
 TEMPERATURE : 24.2 [degC]
 HUMIDITY : 60.0 [%]
 NOTE :

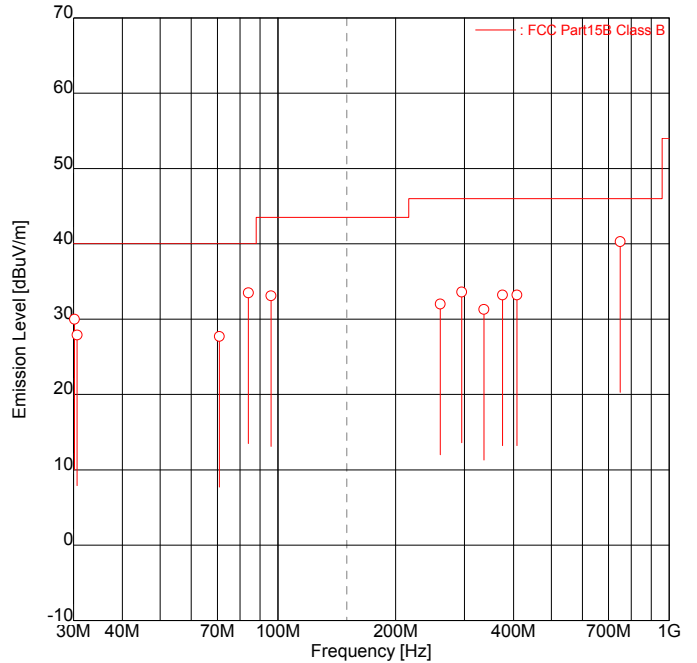

ENGINEER : Koichi Wagatsuma

FREQUENCY [No]	FREQUENCY [MHz]	READING [dBuV]		FACTOR [dB/m]		EMISSION [dBuV/m]		LIMIT [dBuV/m]	MARGIN [dB]	
		Hori	Vert	Hori	Vert	Hori	Vert		Hori	Vert
1	30.20	-	<u>33.4</u>	-3.4	-3.4	-	<u>30.0</u>	40.0	-	<u>10.0</u>
2	30.65	-	<u>31.2</u>	-3.3	-3.3	-	<u>27.9</u>	40.0	-	<u>12.1</u>
3	70.88	<u>30.7</u>	-	-3.0	-3.0	<u>27.7</u>	-	40.0	<u>12.3</u>	-
4	84.05	36.9	<u>39.3</u>	-5.8	-5.8	31.1	<u>33.5</u>	40.0	8.9	<u>6.5</u>
5	96.02	37.4	<u>39.1</u>	-6.0	-6.0	31.4	<u>33.1</u>	43.5	12.1	<u>10.4</u>
6	259.90	32.6	-	-0.6	-0.6	32.0	-	46.0	14.0	-
7	294.90	32.6	-	1.0	1.0	33.6	-	46.0	12.4	-
8	336.20	29.0	-	2.3	2.3	31.3	-	46.0	14.7	-
9	375.06	27.1	29.7	3.5	3.5	30.6	33.2	46.0	15.4	12.8
10	408.23	28.7	-	4.5	4.5	33.2	-	46.0	12.8	-
11	750.11	<u>27.0</u>	26.3	13.3	13.3	<u>40.3</u>	39.6	46.0	<u>5.7</u>	6.4

Higher six points are underlined.
 Other frequencies : Below the FCC Part15B Class B limit
 Emission Level = Read + Factor(Antenna,Antenna Pad,Cable,Preamp)
 ANT. : Used antenna(BBA = Broadband antenna, DIP = Dipole antenna)

1000 - 16000 MHz

Intertek Japan K.K.
Kashima No.12 Test Site
Radiated Electric Field

APPLICANT : JVC KENWOOD Corporation
 EUT NAME : 144/440MHz FM DUAL BANDER
 MODEL NO. : TM-D710GA
 SERIAL NO. : B3600176
 TEST MODE : RX mode (A Band:118.05MHz/B Band:
 800.05MHz)
 POWER SOURCE : DC 13.8V (AC120V 60Hz)
 DATE TESTED : Aug 06 2013
 FILE NO. : -
 REGULATION : FCC Part15B Class B
 TEST METHOD : ANSI C63.4-2003
 DISTANCE : 3.00 [m]
 TEMPERATURE : 24.5 [degC]
 HUMIDITY : 64.0 [%]
 NOTE :

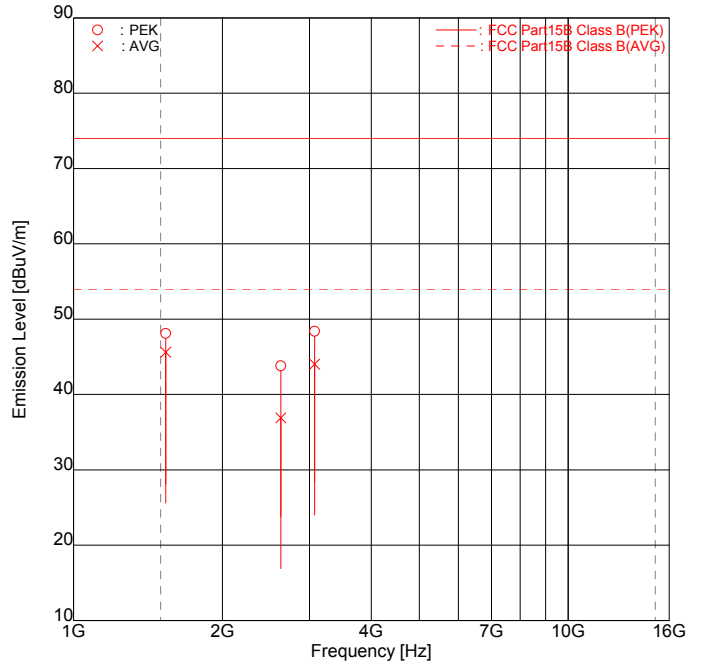

ENGINEER : Koichi Wagatsuma

FREQUENCY [No]	MODE [MHz]		READING [dBuV]		FACTOR [dB/m]		EMISSION [dBuV/m]		LIMIT [dBuV/m]	MARGIN [dB]	
			Hori	Vert	Hori	Vert	Hori	Vert		Hori	Vert
1	1536.85	PEK	50.4	<u>52.4</u>	-4.3	-4.3	46.1	<u>48.1</u>	74.0	27.9	<u>25.9</u>
2	1536.85	AVG	46.8	<u>49.9</u>	-4.3	-4.3	42.5	<u>45.6</u>	54.0	11.5	<u>8.4</u>
3	2625.58	PEK	-	<u>44.7</u>	-0.9	-0.9	-	<u>43.8</u>	74.0	-	<u>30.2</u>
4	2625.58	AVG	-	<u>37.8</u>	-0.9	-0.9	-	<u>36.9</u>	54.0	-	<u>17.1</u>
5	3073.63	PEK	46.0	<u>47.7</u>	0.7	0.7	46.7	<u>48.4</u>	74.0	27.3	<u>25.6</u>
6	3073.63	AVG	39.8	<u>43.3</u>	0.7	0.7	40.5	<u>44.0</u>	54.0	13.5	<u>10.0</u>

Higher six points are underlined.
 Other frequencies : Below the FCC Part15B Class B limit
 Emission Level = Read + Factor(Antenna,Antenna Pad,Cable,Preamp)
 ANT. : Used antenna(BBA = Broadband antenna, DIP = Dipole antenna)

**9.1.2.5 RX mode (A Band :321.05MHz/B Band :1050.05MHz)
 30 - 1000MHz**

Intertek Japan K.K.
Kashima No.12 Test Site
 Radiated Electric Field

APPLICANT : JVC KENWOOD Corporation
 EUT NAME : 144/440MHz FM DUAL BANDER
 MODEL NO. : TM-D710GA
 SERIAL NO. : B3600176
 TEST MODE : RX mode (A Band:321.05MHz/B Band:
 1050.05MHz)
 POWER SOURCE : DC 13.8V (AC120V 60Hz)
 DATE TESTED : Aug 05 2013
 FILE NO. : -
 REGULATION : FCC Part15B Class B
 TEST METHOD : ANSI C63.4-2003
 DISTANCE : 3.00 [m]
 TEMPERATURE : 24.2 [degC]
 HUMIDITY : 60.0 [%]
 NOTE :

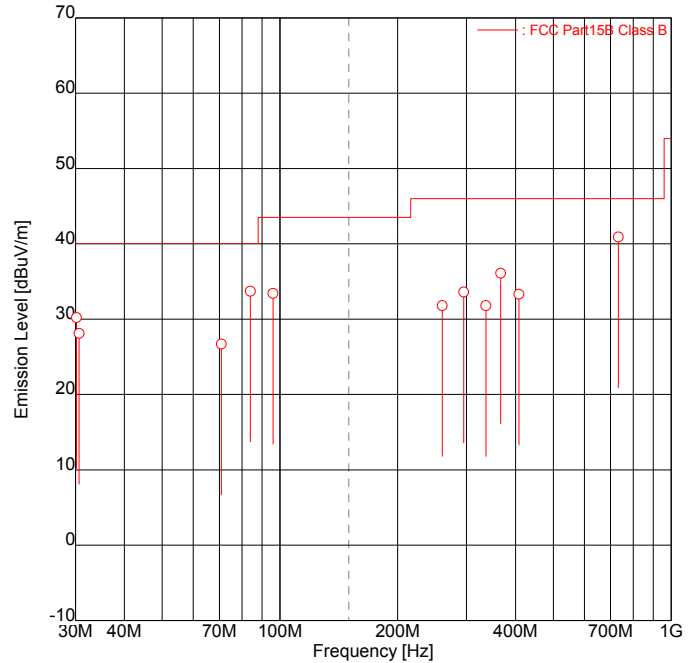

ENGINEER : Koichi Wagatsuma

FREQUENCY [No]	FREQUENCY [MHz]	READING [dBuV]		FACTOR [dB/m]		EMISSION [dBuV/m]		LIMIT [dBuV/m]	MARGIN [dB]	
		Hori	Vert	Hori	Vert	Hori	Vert		Hori	Vert
1	30.20	-	<u>33.6</u>	-3.4	-3.4	-	<u>30.2</u>	40.0	-	<u>9.8</u>
2	30.65	-	<u>31.4</u>	-3.3	-3.3	-	<u>28.1</u>	40.0	-	<u>11.9</u>
3	70.88	29.7	-	-3.0	-3.0	26.7	-	40.0	13.3	-
4	84.05	37.5	<u>39.5</u>	-5.8	-5.8	31.7	<u>33.7</u>	40.0	8.3	<u>6.3</u>
5	96.02	37.3	<u>39.4</u>	-6.0	-6.0	31.3	<u>33.4</u>	43.5	12.2	<u>10.1</u>
6	259.90	32.4	-	-0.6	-0.6	31.8	-	46.0	14.2	-
7	294.90	32.6	-	1.0	1.0	33.6	-	46.0	12.4	-
8	336.20	29.5	-	2.3	2.3	31.8	-	46.0	14.2	-
9	366.67	30.1	<u>32.9</u>	3.2	3.2	33.3	<u>36.1</u>	46.0	12.7	<u>9.9</u>
10	408.23	28.8	-	4.5	4.5	33.3	-	46.0	12.7	-
11	733.34	<u>28.2</u>	26.2	12.7	12.7	<u>40.9</u>	38.9	46.0	<u>5.1</u>	7.1

Higher six points are underlined.
 Other frequencies : Below the FCC Part15B Class B limit
 Emission Level = Read + Factor(Antenna,Antenna Pad,Cable,Preamp)
 ANT. : Used antenna(BBA = Broadband antenna, DIP = Dipole antenna)

1000 - 16000 MHz

Intertek Japan K.K.
Kashima No.12 Test Site
Radiated Electric Field

APPLICANT : JVC KENWOOD Corporation
 EUT NAME : 144/440MHz FM DUAL BANDER
 MODEL NO. : TM-D710GA
 SERIAL NO. : B3600176
 TEST MODE : RX mode (A Band:321.05MHz/B Band:
 1050.05MHz)
 POWER SOURCE : DC 13.8V (AC120V 60Hz)
 DATE TESTED : Aug 06 2013
 FILE NO. : -
 REGULATION : FCC Part15B Class B
 TEST METHOD : ANSI C63.4-2003
 DISTANCE : 3.00 [m]
 TEMPERATURE : 24.5 [degC]
 HUMIDITY : 64.0 [%]
 NOTE :

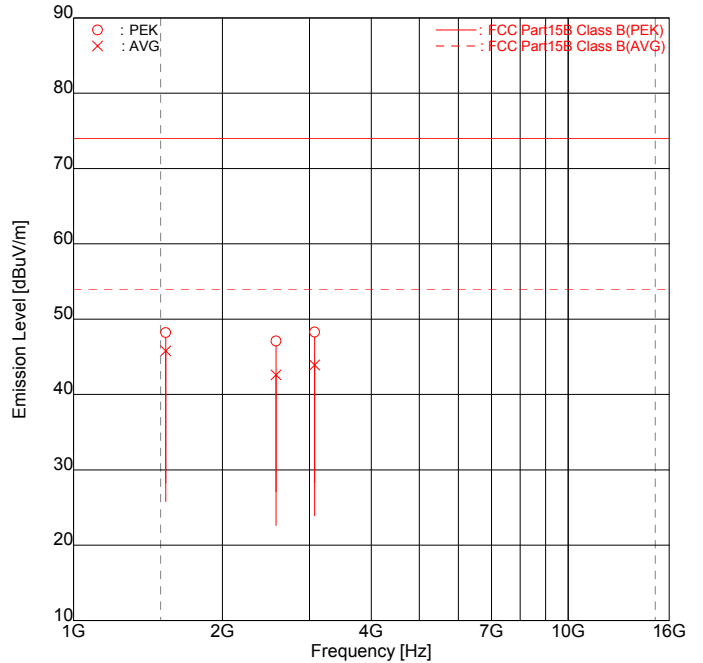

ENGINEER : Koichi Wagatsuma

FREQUENCY [No]	MODE [MHz]		READING [dBuV]		FACTOR [dB/m]		EMISSION [dBuV/m]		LIMIT [dBuV/m]	MARGIN [dB]	
			Hori	Vert	Hori	Vert	Hori	Vert		Hori	Vert
1	1536.85	PEK	50.7	<u>52.5</u>	-4.3	-4.3	46.4	<u>48.2</u>	74.0	27.6	<u>25.8</u>
2	1536.85	AVG	47.3	<u>50.1</u>	-4.3	-4.3	43.0	<u>45.8</u>	54.0	11.0	<u>8.2</u>
3	2566.83	PEK	45.3	<u>48.2</u>	-1.1	-1.1	44.2	<u>47.1</u>	74.0	29.8	<u>26.9</u>
4	2566.83	AVG	38.2	<u>43.7</u>	-1.1	-1.1	37.1	<u>42.6</u>	54.0	16.9	<u>11.4</u>
5	3073.63	PEK	45.5	<u>47.6</u>	0.7	0.7	46.2	<u>48.3</u>	74.0	27.8	<u>25.7</u>
6	3073.63	AVG	39.8	<u>43.2</u>	0.7	0.7	40.5	<u>43.9</u>	54.0	13.5	<u>10.1</u>

Higher six points are underlined.
 Other frequencies : Below the FCC Part15B Class B limit
 Emission Level = Read + Factor(Antenna,Antenna Pad,Cable,Preamp)
 ANT. : Used antenna(BBA = Broadband antenna, DIP = Dipole antenna)

**9.1.2.6 RX mode (A Band :523.95MHz/B Band :1299.95MHz)
 30 - 1000MHz**

Intertek Japan K.K.
Kashima No.12 Test Site
 Radiated Electric Field

APPLICANT : JVC KENWOOD Corporation
 EUT NAME : 144/440MHz FM DUAL BANDER
 MODEL NO. : TM-D710GA
 SERIAL NO. : B3600176
 TEST MODE : RX mode (A Band:523.95MHz/B Band:
 1299.95MHz)
 POWER SOURCE : DC 13.8V (AC120V 60Hz)
 DATE TESTED : Aug 05 2013
 FILE NO. : -
 REGULATION : FCC Part15B Class B
 TEST METHOD : ANSI C63.4-2003
 DISTANCE : 3.00 [m]
 TEMPERATURE : 24.2 [degC]
 HUMIDITY : 60.0 [%]
 NOTE :

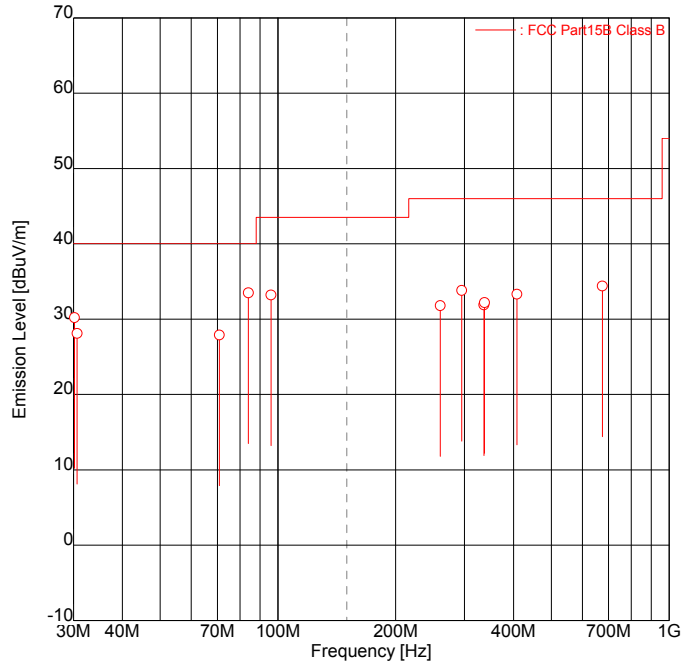

ENGINEER : Koichi Wagatsuma

FREQUENCY [No]	FREQUENCY [MHz]	READING [dBuV]		FACTOR [dB/m]		EMISSION [dBuV/m]		LIMIT [dBuV/m]	MARGIN [dB]	
		Hori	Vert	Hori	Vert	Hori	Vert		Hori	Vert
1	30.20	-	<u>33.6</u>	-3.4	-3.4	-	<u>30.2</u>	40.0	-	<u>9.8</u>
2	30.65	-	<u>31.4</u>	-3.3	-3.3	-	<u>28.1</u>	40.0	-	<u>11.9</u>
3	70.88	<u>30.9</u>	-	-3.0	-3.0	<u>27.9</u>	-	40.0	<u>12.1</u>	-
4	84.05	36.8	<u>39.3</u>	-5.8	-5.8	31.0	<u>33.5</u>	40.0	9.0	<u>6.5</u>
5	96.02	37.3	<u>39.2</u>	-6.0	-6.0	31.3	<u>33.2</u>	43.5	12.2	<u>10.3</u>
6	259.90	32.4	-	-0.6	-0.6	31.8	-	46.0	14.2	-
7	294.90	32.8	-	1.0	1.0	33.8	-	46.0	12.2	-
8	336.20	29.6	-	2.3	2.3	31.9	-	46.0	14.1	-
9	337.48	27.2	29.8	2.4	2.4	29.6	32.2	46.0	16.4	13.8
10	408.23	28.8	-	4.5	4.5	33.3	-	46.0	12.7	-
11	674.95	<u>23.1</u>	21.2	11.3	11.3	<u>34.4</u>	32.5	46.0	<u>11.6</u>	13.5

Higher six points are underlined.
 Other frequencies : Below the FCC Part15B Class B limit
 Emission Level = Read + Factor(Antenna,Antenna Pad,Cable,Preamp)
 ANT. : Used antenna(BBA = Broadband antenna, DIP = Dipole antenna)

1000 - 16000 MHz

Intertek Japan K.K.
Kashima No.12 Test Site
Radiated Electric Field

APPLICANT : JVC KENWOOD Corporation
 EUT NAME : 144/440MHz FM DUAL BANDER
 MODEL NO. : TM-D710GA
 SERIAL NO. : B3600176
 TEST MODE : RX mode (A Band:523.95MHz/B Band:
 1299.95MHz)
 POWER SOURCE : DC 13.8V (AC120V 60Hz)
 DATE TESTED : Aug 06 2013
 FILE NO. : -
 REGULATION : FCC Part15B Class B
 TEST METHOD : ANSI C63.4-2003
 DISTANCE : 3.00 [m]
 TEMPERATURE : 24.5 [degC]
 HUMIDITY : 64.0 [%]
 NOTE :

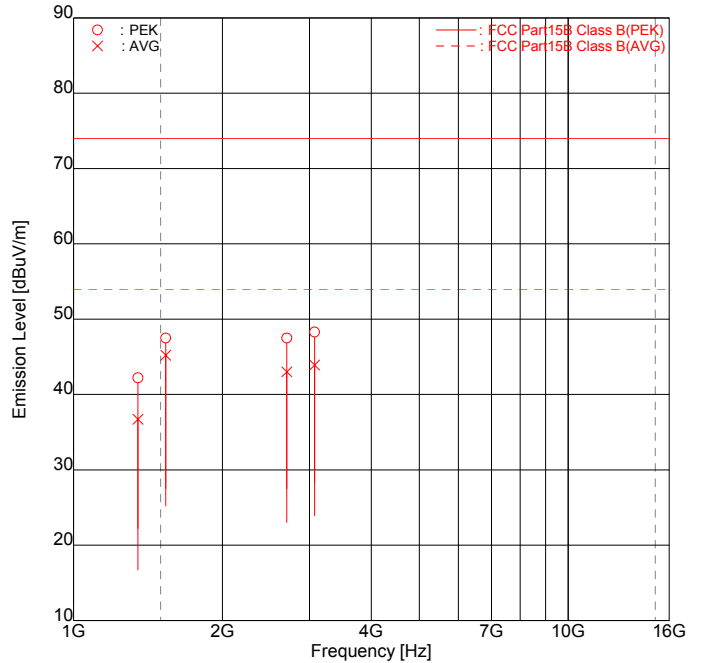

ENGINEER : Koichi Wagatsuma

FREQUENCY [No]	MODE [MHz]		READING [dBuV]		FACTOR [dB/m]		EMISSION [dBuV/m]		LIMIT [dBuV/m]	MARGIN [dB]	
			Hori	Vert	Hori	Vert	Hori	Vert		Hori	Vert
1	1349.94	PEK	46.3	47.0	-4.8	-4.8	41.5	42.2	74.0	32.5	31.8
2	1349.94	AVG	40.2	<u>41.5</u>	-4.8	-4.8	35.4	<u>36.7</u>	54.0	18.6	<u>17.3</u>
3	1536.85	PEK	50.1	<u>51.8</u>	-4.3	-4.3	45.8	<u>47.5</u>	74.0	28.2	<u>26.5</u>
4	1536.85	AVG	46.8	<u>49.5</u>	-4.3	-4.3	42.5	<u>45.2</u>	54.0	11.5	<u>8.8</u>
5	2699.97	PEK	44.9	<u>48.2</u>	-0.7	-0.7	44.2	<u>47.5</u>	74.0	29.8	<u>26.5</u>
6	2699.97	AVG	36.6	<u>43.7</u>	-0.7	-0.7	35.9	<u>43.0</u>	54.0	18.1	<u>11.0</u>
7	3073.63	PEK	45.4	<u>47.6</u>	0.7	0.7	46.1	<u>48.3</u>	74.0	27.9	<u>25.7</u>
8	3073.63	AVG	39.5	<u>43.2</u>	0.7	0.7	40.2	<u>43.9</u>	54.0	13.8	<u>10.1</u>

Higher six points are underlined.

Other frequencies : Below the FCC Part15B Class B limit

Emission Level = Read + Factor(Antenna,Antenna Pad,Cable,Preamp)

ANT. : Used antenna(BBA = Broadband antenna, DIP = Dipole antenna)

**9.1.2.7 VFO SCAN mode(A Band :144MHz Band/B Band : 144MHz Band)
 30 - 1000MHz**

Intertek Japan K.K.
Kashima No.12 Test Site
 Radiated Electric Field

APPLICANT : JVC KENWOOD Corporation
 EUT NAME : 144/440MHz FM DUAL BANDER
 MODEL NO. : TM-D710GA
 SERIAL NO. : B3600176
 TEST MODE : VFO Scan mode (A Band:144MHz Band/B
 Band: 144MHz Band)
 POWER SOURCE : DC 13.8V (AC120V 60Hz)
 DATE TESTED : Aug 05 2013
 FILE NO. : -
 REGULATION : FCC Part15B Class B
 TEST METHOD : ANSI C63.4-2003
 DISTANCE : 3.00 [m]
 TEMPERATURE : 24.2 [degC]
 HUMIDITY : 60.0 [%]
 NOTE : A Band : 136.00MHz - 199.995MHz
 B Band : 136.00MHz - 199.995MHz

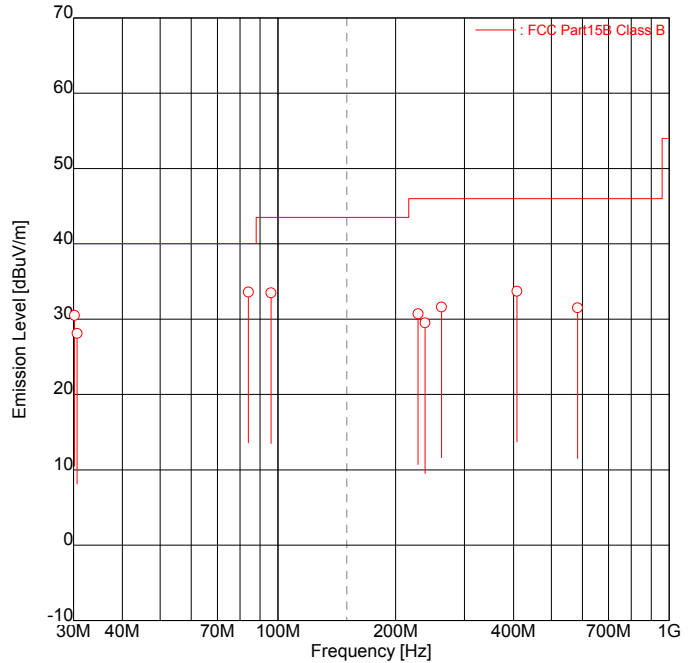

ENGINEER : Katsuya Uchida

FREQUENCY [No]	FREQUENCY [MHz]	READING [dBuV]		FACTOR [dB/m]		EMISSION [dBuV/m]		LIMIT [dBuV/m]	MARGIN [dB]	
		Hori	Vert	Hori	Vert	Hori	Vert		Hori	Vert
1	30.20	-	<u>33.9</u>	-3.4	-3.4	-	<u>30.5</u>	40.0	-	<u>9.5</u>
2	30.65	-	<u>31.4</u>	-3.3	-3.3	-	<u>28.1</u>	40.0	-	<u>11.9</u>
3	84.04	36.6	<u>39.4</u>	-5.8	-5.8	30.8	<u>33.6</u>	40.0	9.2	<u>6.4</u>
4	96.02	36.8	<u>39.5</u>	-6.0	-6.0	30.8	<u>33.5</u>	43.5	12.7	<u>10.0</u>
5	228.13	32.8	-	-2.1	-2.1	30.7	-	46.0	15.3	-
6	237.77	31.1	-	-1.6	-1.6	29.5	-	46.0	16.5	-
7	261.74	<u>32.1</u>	-	-0.5	-0.5	<u>31.6</u>	-	46.0	<u>14.4</u>	-
8	408.22	<u>29.2</u>	-	4.5	4.5	<u>33.7</u>	-	46.0	<u>12.3</u>	-
9	583.63	16.8	21.9	9.6	9.6	26.4	31.5	46.0	19.6	14.5

Higher six points are underlined.
 Other frequencies : Below the FCC Part15B Class B limit
 Emission Level = Read + Factor(Antenna,Antenna Pad,Cable,Preamp)
 ANT. : Used antenna(BBA = Broadband antenna, DIP = Dipole antenna)

1000 - 16000 MHz

Intertek Japan K.K.
Kashima No.12 Test Site
Radiated Electric Field

APPLICANT : JVC KENWOOD Corporation
 EUT NAME : 144/440MHz FM DUAL BANDER
 MODEL NO. : TM-D710GA
 SERIAL NO. : B3600176
 TEST MODE : VFO Scan mode (A Band:144MHz Band/B
 Band: 144MHz Band)
 POWER SOURCE : DC 13.8V (AC120V 60Hz)
 DATE TESTED : Aug 06 2013
 FILE NO. : -
 REGULATION : FCC Part15B Class B
 TEST METHOD : ANSI C63.4-2003
 DISTANCE : 3.00 [m]
 TEMPERATURE : 24.5 [degC]
 HUMIDITY : 64.0 [%]
 NOTE : A Band : 136.00MHz - 199.995MHz
 B Band : 136.00MHz - 199.995MHz

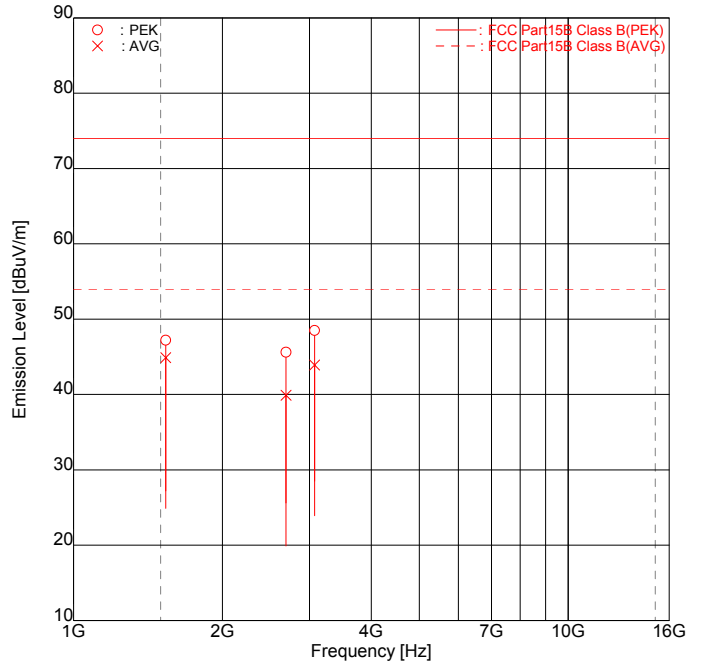

ENGINEER : Katsuya Uchida

FREQUENCY [No]	MODE [MHz]		READING [dBuV]		FACTOR [dB/m]		EMISSION [dBuV/m]		LIMIT [dBuV/m]	MARGIN [dB]	
			Hori	Vert	Hori	Vert	Hori	Vert		Hori	Vert
1	1536.90	PEK	50.3	<u>51.5</u>	-4.3	-4.3	46.0	<u>47.2</u>	74.0	28.0	<u>26.8</u>
2	1536.90	AVG	47.1	<u>49.2</u>	-4.3	-4.3	42.8	<u>44.9</u>	54.0	11.2	<u>9.1</u>
3	2691.01	PEK	44.2	<u>46.3</u>	-0.7	-0.7	43.5	<u>45.6</u>	74.0	30.5	<u>28.4</u>
4	2691.01	AVG	34.9	<u>40.6</u>	-0.7	-0.7	34.2	<u>39.9</u>	54.0	19.8	<u>14.1</u>
5	3073.79	PEK	45.9	<u>47.8</u>	0.7	0.7	46.6	<u>48.5</u>	74.0	27.4	<u>25.5</u>
6	3073.79	AVG	39.7	<u>43.2</u>	0.7	0.7	40.4	<u>43.9</u>	54.0	13.6	<u>10.1</u>

Higher six points are underlined.
 Other frequencies : Below the FCC Part15B Class B limit
 Emission Level = Read + Factor(Antenna,Antenna Pad,Cable,Preamp)
 ANT. : Used antenna(BBA = Broadband antenna, DIP = Dipole antenna)

**9.1.2.8 VFO SCAN mode(A Band :220MHz Band/B Band : 220MHz Band)
 30 - 1000MHz**

Intertek Japan K.K.
Kashima No.12 Test Site
 Radiated Electric Field

APPLICANT : JVC KENWOOD Corporation
 EUT NAME : 144/440MHz FM DUAL BANDER
 MODEL NO. : TM-D710GA
 SERIAL NO. : B3600176
 TEST MODE : VFO Scan mode (A Band:220MHz Band/B
 Band: 220MHz Band)
 POWER SOURCE : DC 13.8V (AC120V 60Hz)
 DATE TESTED : Aug 05 2013
 FILE NO. : -
 REGULATION : FCC Part15B Class B
 TEST METHOD : ANSI C63.4-2003
 DISTANCE : 3.00 [m]
 TEMPERATURE : 24.2 [degC]
 HUMIDITY : 60.0 [%]
 NOTE : A Band : 200.00MHz - 299.995MHz
 B Band : 200.00MHz - 299.995MHz

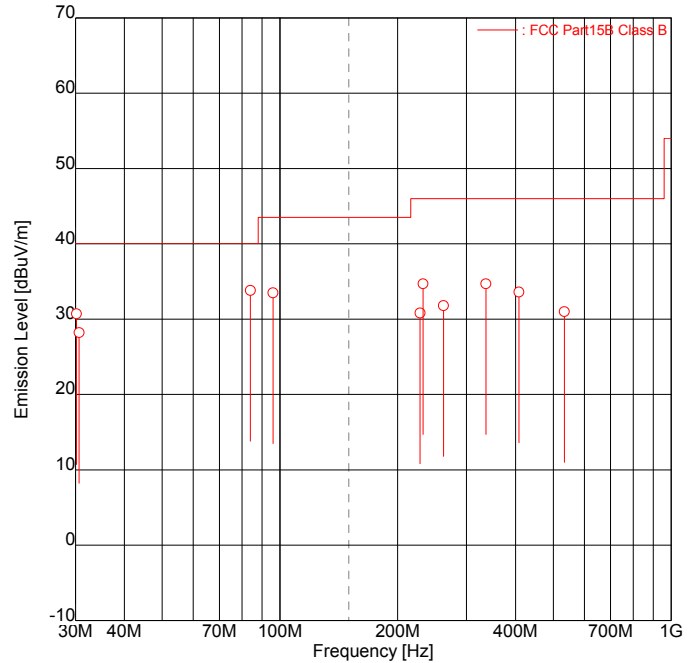

ENGINEER : Katsuya Uchida

FREQUENCY [No]	FREQUENCY [MHz]	READING [dBuV]		FACTOR [dB/m]		EMISSION [dBuV/m]		LIMIT [dBuV/m]	MARGIN [dB]	
		Hori	Vert	Hori	Vert	Hori	Vert		Hori	Vert
1	30.20	-	<u>34.1</u>	-3.4	-3.4	-	<u>30.7</u>	40.0	-	<u>9.3</u>
2	30.65	-	<u>31.5</u>	-3.3	-3.3	-	<u>28.2</u>	40.0	-	<u>11.8</u>
3	84.06	37.6	<u>39.6</u>	-5.8	-5.8	31.8	<u>33.8</u>	40.0	8.2	<u>6.2</u>
4	96.02	36.8	<u>39.5</u>	-6.0	-6.0	30.8	<u>33.5</u>	43.5	12.7	<u>10.0</u>
5	228.13	32.9	-	-2.1	-2.1	30.8	-	46.0	15.2	-
6	232.24	<u>36.6</u>	-	-1.9	-1.9	<u>34.7</u>	-	46.0	<u>11.3</u>	-
7	261.74	<u>32.3</u>	-	-0.5	-0.5	<u>31.8</u>	-	46.0	<u>14.2</u>	-
8	336.18	<u>32.4</u>	30.8	2.3	2.3	<u>34.7</u>	33.1	46.0	<u>11.3</u>	12.9
9	408.22	<u>29.1</u>	-	4.5	4.5	<u>33.6</u>	-	46.0	<u>12.4</u>	-
10	533.63	17.1	22.8	8.2	8.2	25.3	31.0	46.0	20.7	15.0

Higher six points are underlined.
 Other frequencies : Below the FCC Part15B Class B limit
 Emission Level = Read + Factor(Antenna,Antenna Pad,Cable,Preamp)
 ANT. : Used antenna(BBA = Broadband antenna, DIP = Dipole antenna)

1000 - 16000 MHz

Intertek Japan K.K.
 Kashima No.12 Test Site
 Radiated Electric Field

APPLICANT : JVC KENWOOD Corporation
 EUT NAME : 144/440MHz FM DUAL BANDER
 MODEL NO. : TM-D710GA
 SERIAL NO. : B3600176
 TEST MODE : VFO Scan mode (A Band:220MHz Band/B
 Band: 220MHz Band)
 POWER SOURCE : DC 13.8V (AC120V 60Hz)
 DATE TESTED : Aug 06 2013
 FILE NO. : -
 REGULATION : FCC Part15B Class B
 TEST METHOD : ANSI C63.4-2003
 DISTANCE : 3.00 [m]
 TEMPERATURE : 24.5 [degC]
 HUMIDITY : 64.0 [%]
 NOTE : A Band : 200.00MHz - 299.995MHz
 B Band : 200.00MHz - 299.995MHz

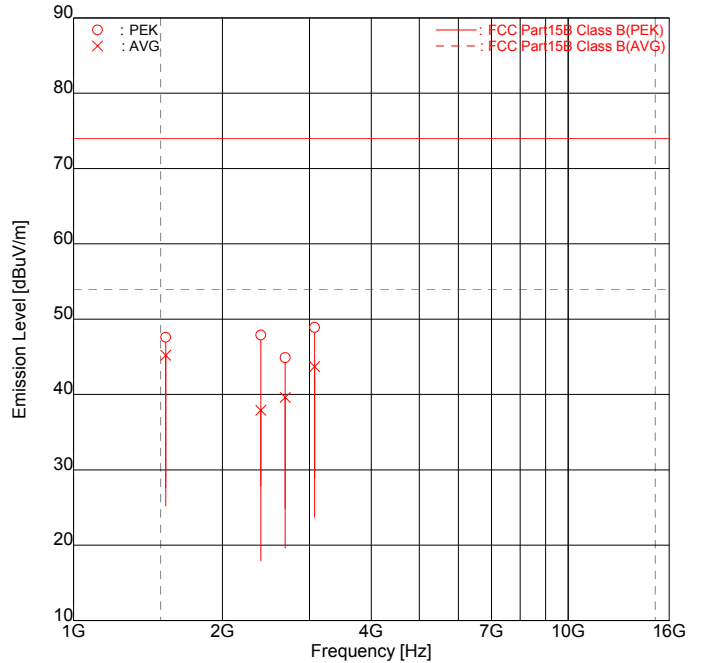

ENGINEER : Katsuya Uchida

FREQUENCY [No]	MODE [MHz]		READING [dBuV]		FACTOR [dB/m]		EMISSION [dBuV/m]		LIMIT [dBuV/m]	MARGIN [dB]	
			Hori	Vert	Hori	Vert	Hori	Vert		Hori	Vert
1	1536.85	PEK	50.5	51.9	-4.3	-4.3	46.2	47.6	74.0	27.8	26.4
2	1536.85	AVG	47.2	<u>49.5</u>	-4.3	-4.3	42.9	<u>45.2</u>	54.0	11.1	<u>8.8</u>
3	2392.26	PEK	48.3	<u>49.5</u>	-1.6	-1.6	46.7	<u>47.9</u>	74.0	27.3	<u>26.1</u>
4	2392.26	AVG	35.2	<u>39.5</u>	-1.6	-1.6	33.6	<u>37.9</u>	54.0	20.4	<u>16.1</u>
5	2679.02	PEK	43.9	45.6	-0.7	-0.7	43.2	44.9	74.0	30.8	29.1
6	2679.02	AVG	34.6	<u>40.3</u>	-0.7	-0.7	33.9	<u>39.6</u>	54.0	20.1	<u>14.4</u>
7	3073.70	PEK	46.1	<u>48.2</u>	0.7	0.7	46.8	<u>48.9</u>	74.0	27.2	<u>25.1</u>
8	3073.70	AVG	39.6	<u>43.0</u>	0.7	0.7	40.3	<u>43.7</u>	54.0	13.7	<u>10.3</u>

Higher six points are underlined.
 Other frequencies : Below the FCC Part15B Class B limit
 Emission Level = Read + Factor(Antenna,Antenna Pad,Cable,Preamp)
 ANT. : Used antenna(BBA = Broadband antenna, DIP = Dipole antenna)

**9.1.2.9 VFO SCAN mode(A Band :300MHz Band/B Band : 300MHz Band)
 30 - 1000MHz**

Intertek Japan K.K.
Kashima No.12 Test Site
 Radiated Electric Field

APPLICANT : JVC KENWOOD Corporation
 EUT NAME : 144/440MHz FM DUAL BANDER
 MODEL NO. : TM-D710GA
 SERIAL NO. : B3600176
 TEST MODE : VFO Scan mode (A Band:300MHz Band/B
 Band: 300MHz Band)
 POWER SOURCE : DC 13.8V (AC120V 60Hz)
 DATE TESTED : Aug 05 2013
 FILE NO. : -
 REGULATION : FCC Part15B Class B
 TEST METHOD : ANSI C63.4-2003
 DISTANCE : 3.00 [m]
 TEMPERATURE : 24.2 [degC]
 HUMIDITY : 60.0 [%]
 NOTE : A Band : 300.00MHz - 399.995MHz
 B Band : 300.00MHz - 399.995MHz

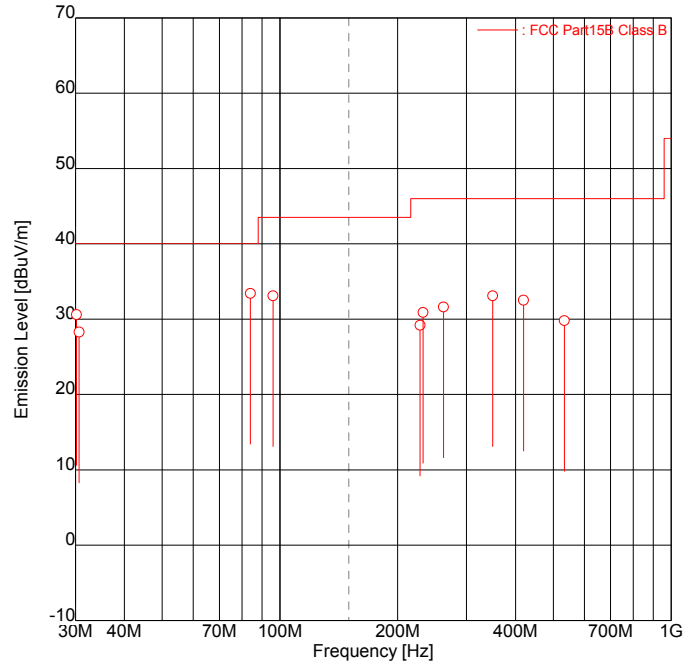

ENGINEER : Katsuya Uchida

FREQUENCY [No]	FREQUENCY [MHz]	READING [dBuV]		FACTOR [dB/m]		EMISSION [dBuV/m]		LIMIT [dBuV/m]	MARGIN [dB]	
		Hori	Vert	Hori	Vert	Hori	Vert		Hori	Vert
1	30.20	-	<u>34.0</u>	-3.4	-3.4	-	<u>30.6</u>	40.0	-	<u>9.4</u>
2	30.65	-	<u>31.6</u>	-3.3	-3.3	-	<u>28.3</u>	40.0	-	<u>11.7</u>
3	84.06	37.2	<u>39.2</u>	-5.8	-5.8	31.4	<u>33.4</u>	40.0	8.6	<u>6.6</u>
4	96.02	36.6	<u>39.1</u>	-6.0	-6.0	30.6	<u>33.1</u>	43.5	12.9	<u>10.4</u>
5	228.13	31.3	-	-2.1	-2.1	29.2	-	46.0	16.8	-
6	232.24	32.8	-	-1.9	-1.9	30.9	-	46.0	15.1	-
7	261.74	32.1	-	-0.5	-0.5	31.6	-	46.0	14.4	-
8	349.95	27.2	<u>30.5</u>	2.6	2.6	29.8	<u>33.1</u>	46.0	16.2	<u>12.9</u>
9	419.35	27.4	<u>27.5</u>	5.0	5.0	32.4	<u>32.5</u>	46.0	13.6	<u>13.5</u>
10	533.50	19.3	21.6	8.2	8.2	27.5	29.8	46.0	18.5	16.2

Higher six points are underlined.
 Other frequencies : Below the FCC Part15B Class B limit
 Emission Level = Read + Factor(Antenna,Antenna Pad,Cable,Preamp)
 ANT. : Used antenna(BBA = Broadband antenna, DIP = Dipole antenna)

1000 - 16000 MHz

Intertek Japan K.K.
Kashima No.12 Test Site
Radiated Electric Field

APPLICANT : JVC KENWOOD Corporation
 EUT NAME : 144/440MHz FM DUAL BANDER
 MODEL NO. : TM-D710GA
 SERIAL NO. : B3600176
 TEST MODE : VFO Scan mode (A Band:300MHz Band/B
 Band: 300MHz Band)
 POWER SOURCE : DC 13.8V (AC120V 60Hz)
 DATE TESTED : Aug 06 2013
 FILE NO. : -
 REGULATION : FCC Part15B Class B
 TEST METHOD : ANSI C63.4-2003
 DISTANCE : 3.00 [m]
 TEMPERATURE : 24.5 [degC]
 HUMIDITY : 64.0 [%]
 NOTE : A Band : 300.00MHz - 399.995MHz
 B Band : 300.00MHz - 399.995MHz

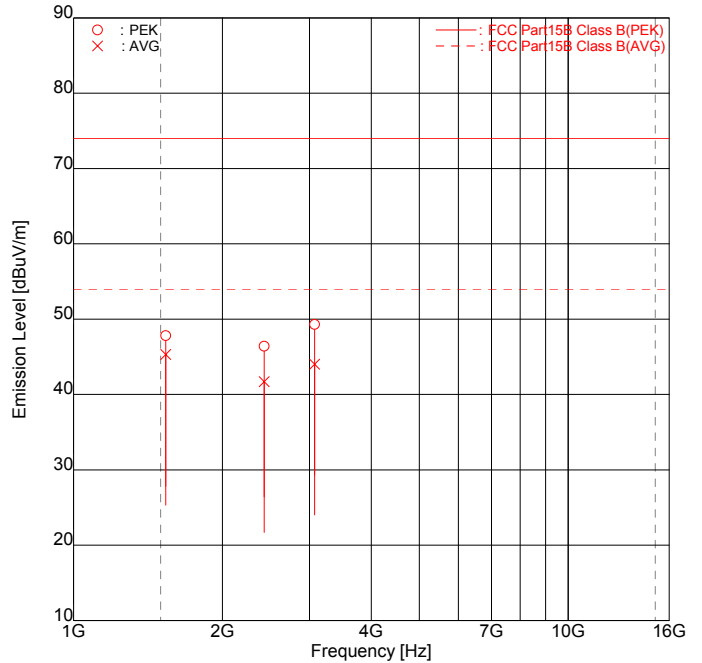

ENGINEER : Katsuya Uchida

FREQUENCY [No]	MODE [MHz]		READING [dBuV]		FACTOR [dB/m]		EMISSION [dBuV/m]		LIMIT [dBuV/m]	MARGIN [dB]	
			Hori	Vert	Hori	Vert	Hori	Vert		Hori	Vert
1	1536.88	PEK	50.8	<u>52.1</u>	-4.3	-4.3	46.5	<u>47.8</u>	74.0	27.5	<u>26.2</u>
2	1536.88	AVG	47.5	<u>49.6</u>	-4.3	-4.3	43.2	<u>45.3</u>	54.0	10.8	<u>8.7</u>
3	2429.72	PEK	46.4	<u>47.9</u>	-1.5	-1.5	44.9	<u>46.4</u>	74.0	29.1	<u>27.6</u>
4	2429.72	AVG	39.8	<u>43.2</u>	-1.5	-1.5	38.3	<u>41.7</u>	54.0	15.7	<u>12.3</u>
5	3073.68	PEK	46.2	<u>48.6</u>	0.7	0.7	46.9	<u>49.3</u>	74.0	27.1	<u>24.7</u>
6	3073.68	AVG	39.5	<u>43.3</u>	0.7	0.7	40.2	<u>44.0</u>	54.0	13.8	<u>10.0</u>

Higher six points are underlined.

Other frequencies : Below the FCC Part15B Class B limit

Emission Level = Read + Factor(Antenna, Antenna Pad, Cable, Preamp)

ANT. : Used antenna(BBA = Broadband antenna, DIP = Dipole antenna)

**9.1.2.10 VFO SCAN mode(A Band :430MHz Band/B Band : 430MHz Band)
 30 - 1000MHz**

Intertek Japan K.K.
Kashima No.12 Test Site
 Radiated Electric Field

APPLICANT : JVC KENWOOD Corporation
 EUT NAME : 144/440MHz FM DUAL BANDER
 MODEL NO. : TM-D710GA
 SERIAL NO. : B3600176
 TEST MODE : VFO Scan mode (A Band:430MHz Band/B
 Band: 430MHz Band)
 POWER SOURCE : DC 13.8V (AC120V 60Hz)
 DATE TESTED : Aug 05 2013
 FILE NO. : -
 REGULATION : FCC Part15B Class B
 TEST METHOD : ANSI C63.4-2003
 DISTANCE : 3.00 [m]
 TEMPERATURE : 24.2 [degC]
 HUMIDITY : 60.0 [%]
 NOTE : A Band : 400.00MHz - 523.995MHz
 B Band : 400.00MHz - 523.995MHz

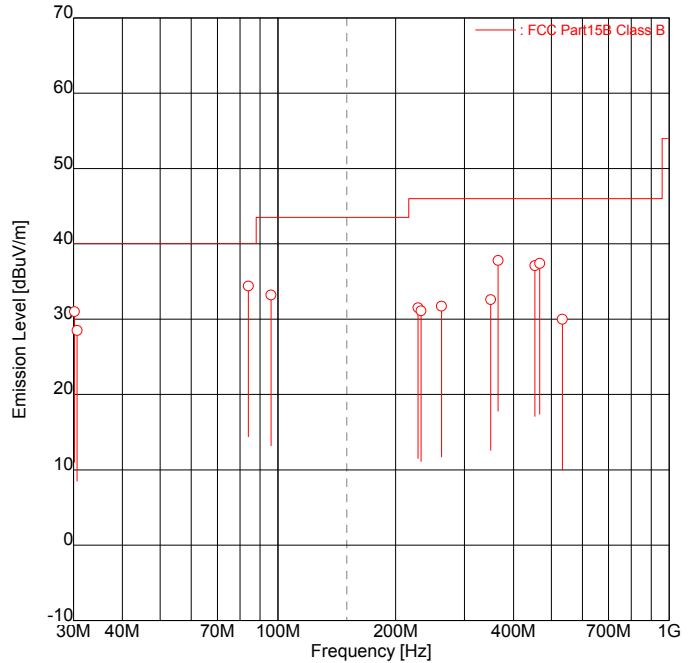

ENGINEER : Katsuya Uchida

FREQUENCY [No]	FREQUENCY [MHz]	READING [dBuV]		FACTOR [dB/m]		EMISSION [dBuV/m]		LIMIT [dBuV/m]	MARGIN [dB]	
		Hori	Vert	Hori	Vert	Hori	Vert		Hori	Vert
1	30.20	-	<u>34.4</u>	-3.4	-3.4	-	<u>31.0</u>	40.0	-	<u>9.0</u>
2	30.65	-	<u>31.8</u>	-3.3	-3.3	-	<u>28.5</u>	40.0	-	<u>11.5</u>
3	84.06	37.5	<u>40.2</u>	-5.8	-5.8	31.7	<u>34.4</u>	40.0	8.3	<u>5.6</u>
4	96.02	36.7	<u>39.2</u>	-6.0	-6.0	30.7	<u>33.2</u>	43.5	12.8	<u>10.3</u>
5	228.13	33.6	-	-2.1	-2.1	31.5	-	46.0	14.5	-
6	232.24	33.0	-	-1.9	-1.9	31.1	-	46.0	14.9	-
7	261.74	32.2	-	-0.5	-0.5	31.7	-	46.0	14.3	-
8	350.06	29.4	30.0	2.6	2.6	32.0	32.6	46.0	14.0	13.4
9	365.65	33.2	<u>34.6</u>	3.2	3.2	36.4	<u>37.8</u>	46.0	9.6	<u>8.2</u>
10	454.16	<u>31.2</u>	25.2	5.9	5.9	<u>37.1</u>	31.1	46.0	<u>8.9</u>	14.9
11	467.05	<u>31.2</u>	25.0	6.2	6.2	<u>37.4</u>	31.2	46.0	<u>8.6</u>	14.8
12	533.50	19.2	21.8	8.2	8.2	27.4	30.0	46.0	18.6	16.0

Higher six points are underlined.
 Other frequencies : Below the FCC Part15B Class B limit
 Emission Level = Read + Factor(Antenna,Antenna Pad,Cable,Preamp)
 ANT. : Used antenna(BBA = Broadband antenna, DIP = Dipole antenna)

1000 - 16000 MHz

Intertek Japan K.K.
Kashima No.12 Test Site
Radiated Electric Field

APPLICANT : JVC KENWOOD Corporation
 EUT NAME : 144/440MHz FM DUAL BANDER
 MODEL NO. : TM-D710GA
 SERIAL NO. : B3600176
 TEST MODE : VFO Scan mode (A Band:430MHz Band/B
 Band: 430MHz Band)
 POWER SOURCE : DC 13.8V (AC120V 60Hz)
 DATE TESTED : Aug 09 2013
 FILE NO. : -
 REGULATION : FCC Part15B Class B
 TEST METHOD : ANSI C63.4-2003
 DISTANCE : 3.00 [m]
 TEMPERATURE : 24.0 [degC]
 HUMIDITY : 52.0 [%]
 NOTE : A Band : 400.00MHz - 523.995MHz
 B Band : 400.00MHz - 523.995MHz

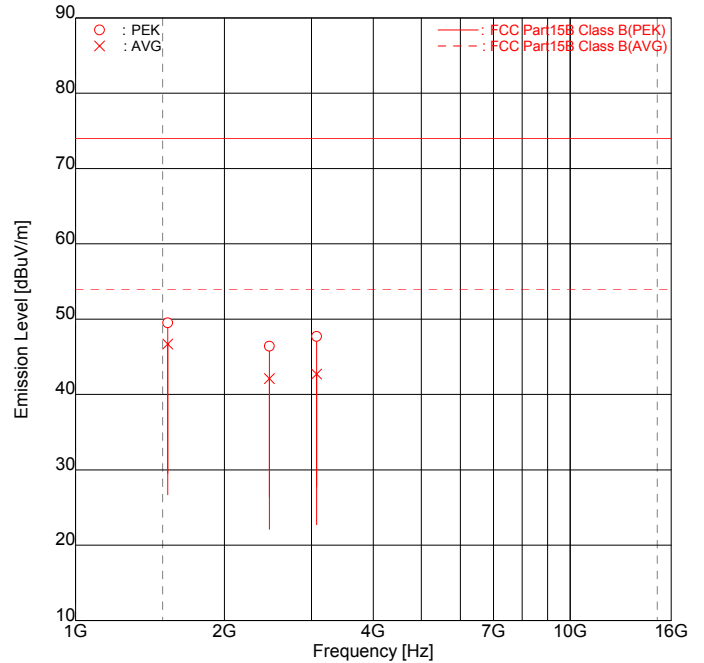

ENGINEER : Koichi Wagatsuma

FREQUENCY [No]	MODE [MHz]		READING [dBuV]		FACTOR [dB/m]		EMISSION [dBuV/m]		LIMIT [dBuV/m]	MARGIN [dB]	
			Hori	Vert	Hori	Vert	Hori	Vert		Hori	Vert
1	1536.88	PEK	51.0	<u>53.8</u>	-4.3	-4.3	46.7	<u>49.5</u>	74.0	27.3	<u>24.5</u>
2	1536.88	AVG	47.3	<u>51.0</u>	-4.3	-4.3	43.0	<u>46.7</u>	54.0	11.0	<u>7.3</u>
3	2466.62	PEK	44.0	<u>47.8</u>	-1.4	-1.4	42.6	<u>46.4</u>	74.0	31.4	<u>27.6</u>
4	2466.62	AVG	34.3	<u>43.5</u>	-1.4	-1.4	32.9	<u>42.1</u>	54.0	21.1	<u>11.9</u>
5	3073.68	PEK	46.2	<u>47.0</u>	0.7	0.7	46.9	<u>47.7</u>	74.0	27.1	<u>26.3</u>
6	3073.68	AVG	41.0	<u>42.0</u>	0.7	0.7	41.7	<u>42.7</u>	54.0	12.3	<u>11.3</u>

Higher six points are underlined.
 Other frequencies : Below the FCC Part15B Class B limit
 Emission Level = Read + Factor(Antenna,Antenna Pad,Cable,Preamp)
 ANT. : Used antenna(BBA = Broadband antenna, DIP = Dipole antenna)

**9.1.2.11 VFO SCAN mode(A Band :118MHz Band/B Band : 1200MHz Band)
 30 - 1000MHz**

Intertek Japan K.K.
Kashima No.12 Test Site
 Radiated Electric Field

APPLICANT : JVC KENWOOD Corporation
 EUT NAME : 144/440MHz FM DUAL BANDER
 MODEL NO. : TM-D710GA
 SERIAL NO. : B3600176
 TEST MODE : VFO Scan mode (A Band:118MHz Band/B
 Band: 1200MHz Band)
 POWER SOURCE : DC 13.8V (AC120V 60Hz)
 DATE TESTED : Aug 05 2013
 FILE NO. : -
 REGULATION : FCC Part15B Class B
 TEST METHOD : ANSI C63.4-2003
 DISTANCE : 3.00 [m]
 TEMPERATURE : 24.2 [degC]
 HUMIDITY : 60.0 [%]
 NOTE : A Band : 118.00MHz - 135.995MHz
 B Band : 800.00MHz - 1299.990MHz

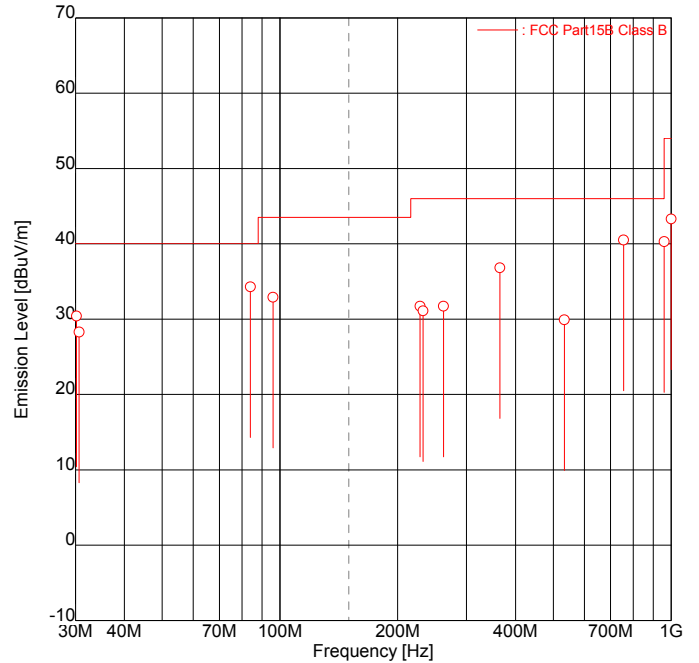

ENGINEER : Katsuya Uchida

FREQUENCY [No]	FREQUENCY [MHz]	READING [dBuV]		FACTOR [dB/m]		EMISSION [dBuV/m]		LIMIT [dBuV/m]	MARGIN [dB]	
		Hori	Vert	Hori	Vert	Hori	Vert		Hori	Vert
1	30.20	-	<u>33.8</u>	-3.4	-3.4	-	<u>30.4</u>	40.0	-	<u>9.6</u>
2	30.65	-	31.6	-3.3	-3.3	-	28.3	40.0	-	11.7
3	84.06	37.4	<u>40.1</u>	-5.8	-5.8	31.6	<u>34.3</u>	40.0	8.4	<u>5.7</u>
4	96.02	36.9	<u>38.9</u>	-6.0	-6.0	30.9	<u>32.9</u>	43.5	12.6	<u>10.6</u>
5	228.13	33.8	-	-2.1	-2.1	31.7	-	46.0	14.3	-
6	232.24	33.0	-	-1.9	-1.9	31.1	-	46.0	14.9	-
7	261.74	32.2	-	-0.5	-0.5	31.7	-	46.0	14.3	-
8	365.09	31.1	<u>33.6</u>	3.2	3.2	34.3	<u>36.8</u>	46.0	11.7	<u>9.2</u>
9	533.50	19.2	<u>21.7</u>	8.2	8.2	27.4	<u>29.9</u>	46.0	18.6	<u>16.1</u>
10	755.56	<u>27.1</u>	27.0	13.4	13.4	<u>40.5</u>	40.4	46.0	<u>5.5</u>	5.6
11	959.86	<u>23.6</u>	23.4	16.7	16.7	<u>40.3</u>	40.1	46.0	<u>5.7</u>	5.9
12	1000.00	25.6	25.8	17.5	17.5	43.1	43.3	54.0	10.9	10.7

Higher six points are underlined.
 Other frequencies : Below the FCC Part15B Class B limit
 Emission Level = Read + Factor(Antenna,Antenna Pad,Cable,Preamp)
 ANT. : Used antenna(BBA = Broadband antenna, DIP = Dipole antenna)

1000 - 16000 MHz

Intertek Japan K.K.
Kashima No.12 Test Site
Radiated Electric Field

APPLICANT : JVC KENWOOD Corporation
 EUT NAME : 144/440MHz FM DUAL BANDER
 MODEL NO. : TM-D710GA
 SERIAL NO. : B3600176
 TEST MODE : VFO Scan mode (A Band:118MHz Band/B
 Band: 1200MHz Band)
 POWER SOURCE : DC 13.8V (AC120V 60Hz)
 DATE TESTED : Aug 09 2013
 FILE NO. : -
 REGULATION : FCC Part15B Class B
 TEST METHOD : ANSI C63.4-2003
 DISTANCE : 3.00 [m]
 TEMPERATURE : 24.0 [degC]
 HUMIDITY : 52.0 [%]
 NOTE : A Band : 118.00MHz - 135.995MHz
 B Band : 800.00MHz - 1299.990MHz

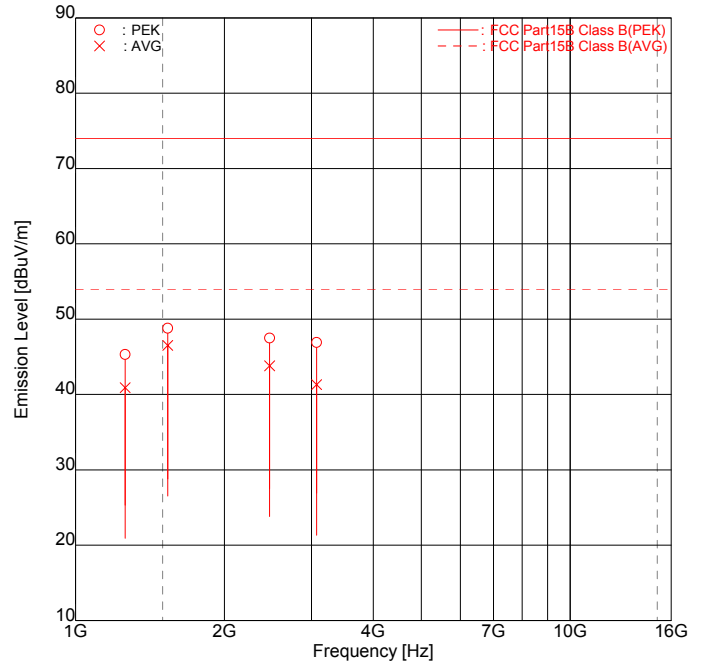

ENGINEER : Koichi Wagatsuma

FREQUENCY [No]	MODE [MHz]		READING [dBuV]		FACTOR [dB/m]		EMISSION [dBuV/m]		LIMIT [dBuV/m]	MARGIN [dB]	
			Hori	Vert	Hori	Vert	Hori	Vert		Hori	Vert
1	1259.95	PEK	50.2	49.6	-4.9	-4.9	45.3	44.7	74.0	28.7	29.3
2	1259.95	AVG	<u>45.8</u>	45.4	-4.9	-4.9	<u>40.9</u>	40.5	54.0	<u>13.1</u>	13.5
3	1536.88	PEK	50.1	<u>53.1</u>	-4.3	-4.3	45.8	<u>48.8</u>	74.0	28.2	<u>25.2</u>
4	1536.88	AVG	46.8	<u>50.8</u>	-4.3	-4.3	42.5	<u>46.5</u>	54.0	11.5	<u>7.5</u>
5	2469.33	PEK	47.4	<u>48.9</u>	-1.4	-1.4	46.0	<u>47.5</u>	74.0	28.0	<u>26.5</u>
6	2469.33	AVG	42.7	<u>45.2</u>	-1.4	-1.4	41.3	<u>43.8</u>	54.0	12.7	<u>10.2</u>
7	3073.68	PEK	45.9	46.2	0.7	0.7	46.6	46.9	74.0	27.4	27.1
8	3073.68	AVG	39.4	<u>40.6</u>	0.7	0.7	40.1	<u>41.3</u>	54.0	13.9	<u>12.7</u>

Higher six points are underlined.
 Other frequencies : Below the FCC Part15B Class B limit
 Emission Level = Read + Factor(Antenna,Antenna Pad,Cable,Preamp)
 ANT. : Used antenna(BBA = Broadband antenna, DIP = Dipole antenna)

9.1.3 Conducted power on antenna port

Location	Kashima No.3 Test Site
Test Engineer	Koichi Wagatsuma and Katsuya Uchida

Frequency Range of Measurements

Field Strength Emission

Operating mode	Required Frequency Range	Measured Frequency Range
RX mode (A Band :118.05MHz/B Band :136.05MHz) RX mode (A Band :321.05MHz/B Band :330.05MHz) RX mode (A Band :523.95MHz/B Band :523.95MHz) RX mode (A Band :118.05MHz/B Band :800.05MHz) RX mode (A Band :321.05MHz/B Band :1050.05MHz) RX mode (A Band :523.95MHz/B Band :1299.95MHz) VFO SCAN mode(A Band :144MHz Band/B Band : 144MHz Band) VFO SCAN mode(A Band :220MHz Band/B Band : 220MHz Band) VFO SCAN mode(A Band :300MHz Band/B Band : 300MHz Band) VFO SCAN mode(A Band :430MHz Band/B Band : 430MHz Band) VFO SCAN mode(A Band :118MHz Band/B Band : 1200MHz Band)	30 – 16000 MHz	30 – 16000 MHz

Test Procedure

Item	Document number
Conducted power on antenna port	RJP-TE101

Setting for the Measuring instruments

Frequency [MHz]	Instrument	Detector	Resolution Bandwidth	Video Bandwidth
30 – 1000	Receiver	Quasi Peak	120 kHz	N/A
Above 1000	Spectrum Analyzer	Peak	1 MHz	1 MHz

< Measurement data correction >

- * Radiated disturbance
- * Conducted power on antenna port
 - Emission Level [dB μ V] = Meter Reading [dB μ V] + Factor [dB]
 - Margin [dB] = Limit [dB μ V] - Emission Level [dB μ V]
 - * Factor = Pad + Cable Loss – Amplifier Gain

Result of Conducted power on antenna port

**9.1.3.1 RX mode (A Band :118.05MHz/B Band :136.05MHz)
 30 - 1000MHz**

**Intertek Japan K.K.
 Kashima No.3 Test Site
 Conducted Power on Antenna Port**

APPLICANT : JVC KENWOOD Corporation
 EUT NAME : 144/440MHz FM DUAL BANDER
 MODEL NO. : TM-D710GA
 SERIAL NO. : B3600176
 TEST MODE : RX mode (A Band:118.05MHz/B
 Band:136.05MHz)
 POWER SOURCE : DC 13.8V (AC 120V, 60Hz)
 DATE TESTED : Jul 31 2013
 FILE NO. : -
 REGULATION : FCC Part15B (15.111)
 TEST METHOD : ANSI C63.4-2003
 TEMPERATURE : 24.5 [degC]
 HUMIDITY : 51.0 [%]
 NOTE :

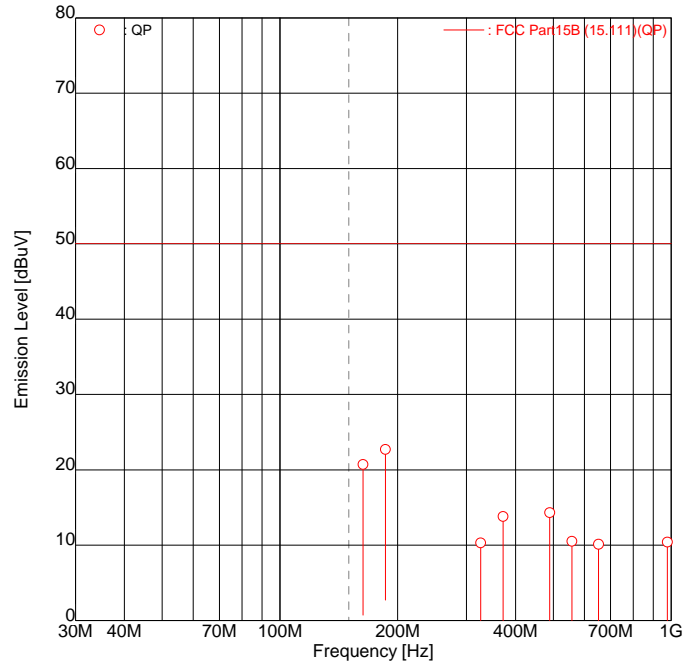

ENGINEER : Koichi Wagatsuma

FREQUENCY [No]	FREQUENCY [MHz]	READING [dBuV]	FACTOR [dB]	EMISSION [dBuV]	LIMIT [dBuV]	MARGIN [dB]
1	163.1060	<u>30.4</u>	-9.7	<u>20.7</u>	50.0	<u>29.3</u>
2	186.0010	<u>32.3</u>	-9.6	<u>22.7</u>	50.0	<u>27.3</u>
3	326.2000	18.9	-8.6	10.3	50.0	39.7
4	372.0120	<u>22.1</u>	-8.3	<u>13.8</u>	50.0	<u>36.2</u>
5	489.3000	<u>21.6</u>	-7.3	<u>14.3</u>	50.0	<u>35.7</u>
6	558.0010	<u>17.7</u>	-7.2	<u>10.5</u>	50.0	<u>39.5</u>
7	652.4000	16.8	-6.7	10.1	50.0	39.9
8	978.6060	<u>15.2</u>	-4.8	<u>10.4</u>	50.0	<u>39.6</u>

Higher six points are underlined.
 Other frequencies : Below the FCC Part15B (15.111) limit
 Emission Level = Read + Factor(Attenuator, Cable, Preamp)

1000 - 16000 MHz

Intertek Japan K.K.
Kashima No.3 Test Site
 Conducted Power on Antenna Port

APPLICANT : JVC KENWOOD Corporation
 EUT NAME : 144/440MHz FM DUAL BANDER
 MODEL NO. : TM-D710GA
 SERIAL NO. : B3600176
 TEST MODE : RX mode (A Band:118.05MHz/B
 Band:136.05MHz)
 POWER SOURCE : DC 13.8V (AC 120V, 60Hz)
 DATE TESTED : Aug 01 2013
 FILE NO. : -
 REGULATION : FCC Part15B (15.111)
 TEST METHOD : ANSI C63.4-2003
 TEMPERATURE : 24.0 [degC]
 HUMIDITY : 52.0 [%]
 NOTE :

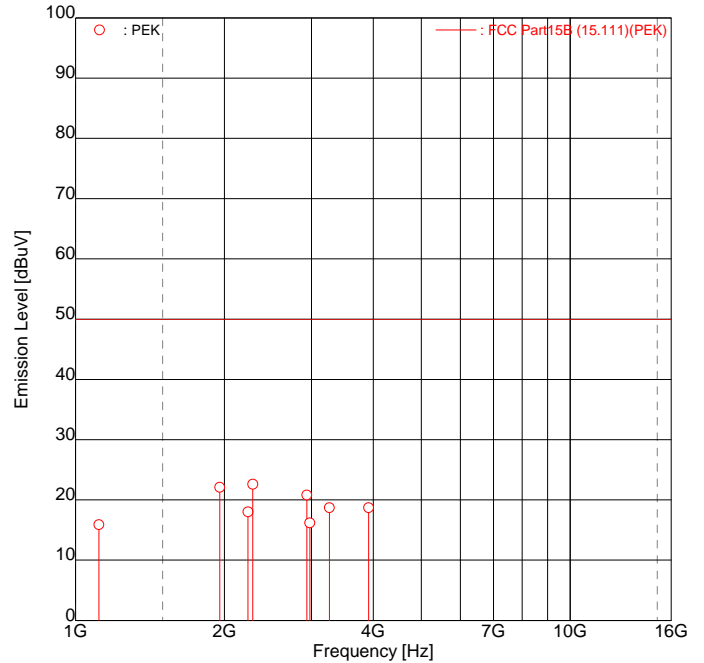

ENGINEER : Koichi Wagatsuma

FREQUENCY [No]	FREQUENCY [MHz]	READING [dBuV]	FACTOR [dB]	EMISSION [dBuV]	LIMIT [dBuV]	MARGIN [dB]
1	1115.9400	46.3	-30.4	15.9	50.0	34.1
2	1957.2100	<u>51.5</u>	-29.4	<u>22.1</u>	50.0	<u>27.9</u>
3	2232.0800	<u>47.5</u>	-29.5	<u>18.0</u>	50.0	<u>32.0</u>
4	2283.4550	<u>52.1</u>	-29.5	<u>22.6</u>	50.0	<u>27.4</u>
5	2935.8450	<u>50.3</u>	-29.5	<u>20.8</u>	50.0	<u>29.2</u>
6	2976.0750	45.7	-29.5	16.2	50.0	33.8
7	3262.0300	<u>47.8</u>	-29.1	<u>18.7</u>	50.0	<u>31.3</u>
8	3914.3400	<u>46.5</u>	-27.8	<u>18.7</u>	50.0	<u>31.3</u>

Higher six points are underlined.
 Other frequencies : Below the FCC Part15B (15.111) limit
 Emission Level = Read + Factor(Pad, Cable, Preamp)
 Limit : 2nW = 50dBuV(50ohm impedance)

**9.1.3.2 RX mode (A Band :321.05MHz/B Band :330.05MHz)
 30 - 1000MHz**

Intertek Japan K.K.
Kashima No.3 Test Site
 Conducted Power on Antenna Port

APPLICANT : JVC KENWOOD Corporation
 EUT NAME : 144/440MHz FM DUAL BANDER
 MODEL NO. : TM-D710GA
 SERIAL NO. : B3600176
 TEST MODE : RX mode (A Band:321.05MHz/B
 Band:330.05MHz)
 POWER SOURCE : DC 13.8V (AC 120V, 60Hz)
 DATE TESTED : Jul 31 2013
 FILE NO. : -
 REGULATION : FCC Part15B (15.111)
 TEST METHOD : ANSI C63.4-2003
 TEMPERATURE : 24.5 [degC]
 HUMIDITY : 51.0 [%]
 NOTE :

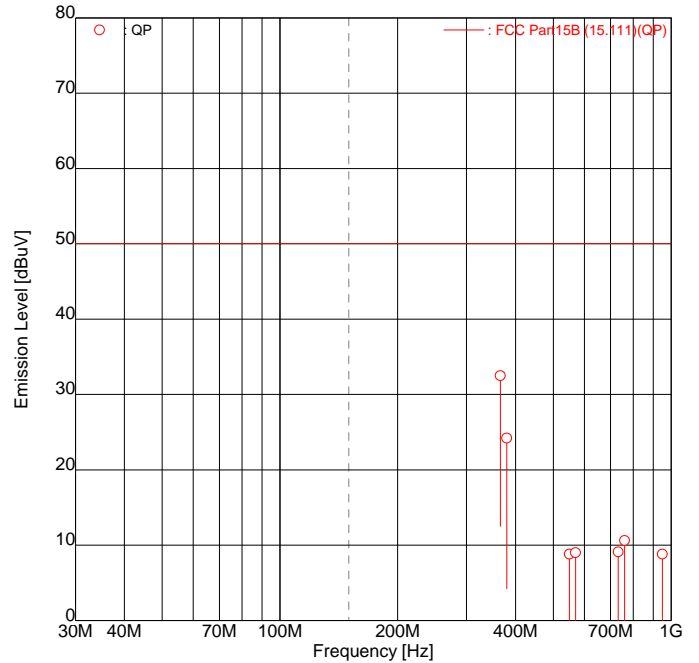

ENGINEER : Koichi Wagatsuma

FREQUENCY [No]	FREQUENCY [MHz]	READING [dBuV]	FACTOR [dB]	EMISSION [dBuV]	LIMIT [dBuV]	MARGIN [dB]
1	366.1008	<u>40.8</u>	-8.3	<u>32.5</u>	50.0	<u>17.5</u>
2	379.9996	<u>32.4</u>	-8.2	<u>24.2</u>	50.0	<u>25.8</u>
3	549.1510	<u>16.0</u>	-7.2	<u>8.8</u>	50.0	<u>41.2</u>
4	569.9750	<u>16.1</u>	-7.1	<u>9.0</u>	50.0	<u>41.0</u>
5	732.2010	<u>15.3</u>	-6.2	<u>9.1</u>	50.0	<u>40.9</u>
6	760.0034	<u>16.5</u>	-5.9	<u>10.6</u>	50.0	<u>39.4</u>
7	949.9849	<u>13.8</u>	-5.0	<u>8.8</u>	50.0	<u>41.2</u>

Higher six points are underlined.
 Other frequencies : Below the FCC Part15B (15.111) limit
 Emission Level = Read + Factor(Attenuator, Cable, Preamp)

1000 - 16000 MHz

Intertek Japan K.K.
Kashima No.3 Test Site
 Conducted Power on Antenna Port

APPLICANT : JVC KENWOOD Corporation
 EUT NAME : 144/440MHz FM DUAL BANDER
 MODEL NO. : TM-D710GA
 SERIAL NO. : B3600176
 TEST MODE : RX mode (A Band:321.05MHz/B
 Band:330.05MHz)
 POWER SOURCE : DC 13.8V (AC 120V, 60Hz)
 DATE TESTED : Aug 01 2013
 FILE NO. : -
 REGULATION : FCC Part15B (15.111)
 TEST METHOD : ANSI C63.4-2003
 TEMPERATURE : 24.0 [degC]
 HUMIDITY : 52.0 [%]
 NOTE :

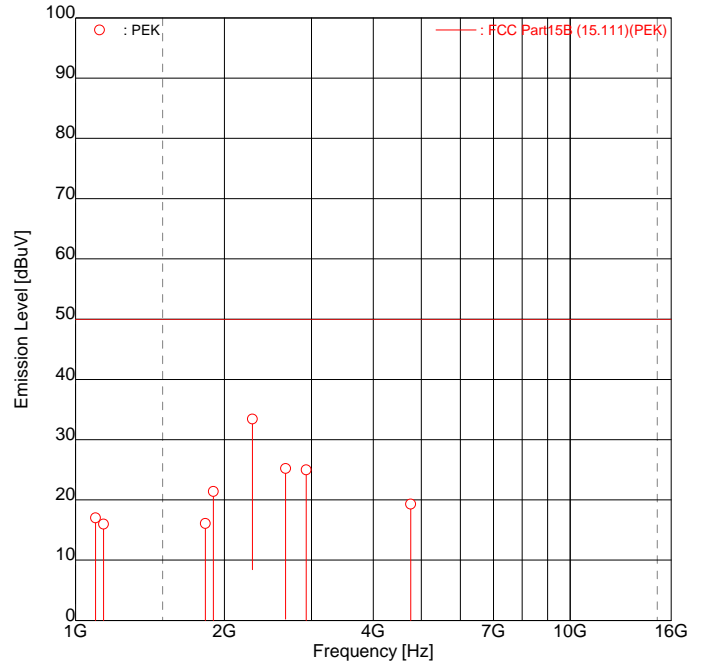

ENGINEER : Koichi Wagatsuma

FREQUENCY [No]	FREQUENCY [MHz]	READING [dBuV]	FACTOR [dB]	EMISSION [dBuV]	LIMIT [dBuV]	MARGIN [dB]
1	1098.2750	<u>47.5</u>	-30.5	<u>17.0</u>	50.0	<u>33.0</u>
2	1139.9500	46.4	-30.4	16.0	50.0	34.0
3	1830.4450	45.7	-29.6	16.1	50.0	33.9
4	1900.0500	<u>50.9</u>	-29.5	<u>21.4</u>	50.0	<u>28.6</u>
5	2279.9850	<u>62.9</u>	-29.5	<u>33.4</u>	50.0	<u>16.6</u>
6	2659.9850	<u>54.8</u>	-29.6	<u>25.2</u>	50.0	<u>24.8</u>
7	2928.6850	<u>54.5</u>	-29.5	<u>25.0</u>	50.0	<u>25.0</u>
8	4759.4050	<u>45.8</u>	-26.5	<u>19.3</u>	50.0	<u>30.7</u>

Higher six points are underlined.
 Other frequencies : Below the FCC Part15B (15.111) limit
 Emission Level = Read + Factor(Pad, Cable, Preamp)
 Limit : 2nW = 50dBuV(50ohm impedance)

**9.1.3.3 RX mode (A Band :523.95MHz/B Band :523.95MHz)
 30 - 1000MHz**

Intertek Japan K.K.
Kashima No.3 Test Site
 Conducted Power on Antenna Port

APPLICANT : JVC KENWOOD Corporation
 EUT NAME : 144/440MHz FM DUAL BANDER
 MODEL NO. : TM-D710GA
 SERIAL NO. : B3600176
 TEST MODE : RX mode (A Band:523.95MHz/B
 Band:523.95MHz)
 POWER SOURCE : DC 13.8V (AC 120V, 60Hz)
 DATE TESTED : Jul 31 2013
 FILE NO. : -
 REGULATION : FCC Part15B (15.111)
 TEST METHOD : ANSI C63.4-2003
 TEMPERATURE : 24.5 [degC]
 HUMIDITY : 51.0 [%]
 NOTE :

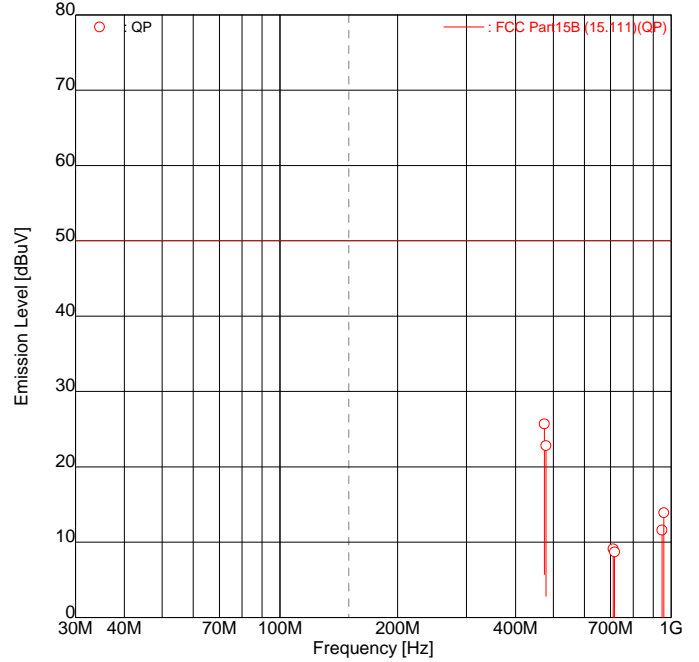

ENGINEER : Koichi Wagatsuma

FREQUENCY [No]	FREQUENCY [MHz]	READING [dBuV]	FACTOR [dB]	EMISSION [dBuV]	LIMIT [dBuV]	MARGIN [dB]
1	474.0036	<u>33.1</u>	-7.4	<u>25.7</u>	50.0	<u>24.3</u>
2	478.9035	<u>30.2</u>	-7.4	<u>22.8</u>	50.0	<u>27.2</u>
3	711.0153	<u>15.4</u>	-6.3	<u>9.1</u>	50.0	<u>40.9</u>
4	717.0467	<u>15.0</u>	-6.3	<u>8.7</u>	50.0	<u>41.3</u>
5	948.0028	<u>16.6</u>	-5.0	<u>11.6</u>	50.0	<u>38.4</u>
6	957.8009	<u>18.8</u>	-4.9	<u>13.9</u>	50.0	<u>36.1</u>

Higher six points are underlined.
 Other frequencies : Below the FCC Part15B (15.111) limit
 Emission Level = Read + Factor(Attenuator, Cable, Preamp)

1000 - 16000 MHz

Intertek Japan K.K.
Kashima No.3 Test Site
 Conducted Power on Antenna Port

APPLICANT : JVC KENWOOD Corporation
 EUT NAME : 144/440MHz FM DUAL BANDER
 MODEL NO. : TM-D710GA
 SERIAL NO. : B3600176
 TEST MODE : RX mode (A Band:523.95MHz/B
 Band:523.95MHz)
 POWER SOURCE : DC 13.8V (AC 120V, 60Hz)
 DATE TESTED : Aug 01 2013
 FILE NO. : -
 REGULATION : FCC Part15B (15.111)
 TEST METHOD : ANSI C63.4-2003
 TEMPERATURE : 24.0 [degC]
 HUMIDITY : 52.0 [%]
 NOTE :

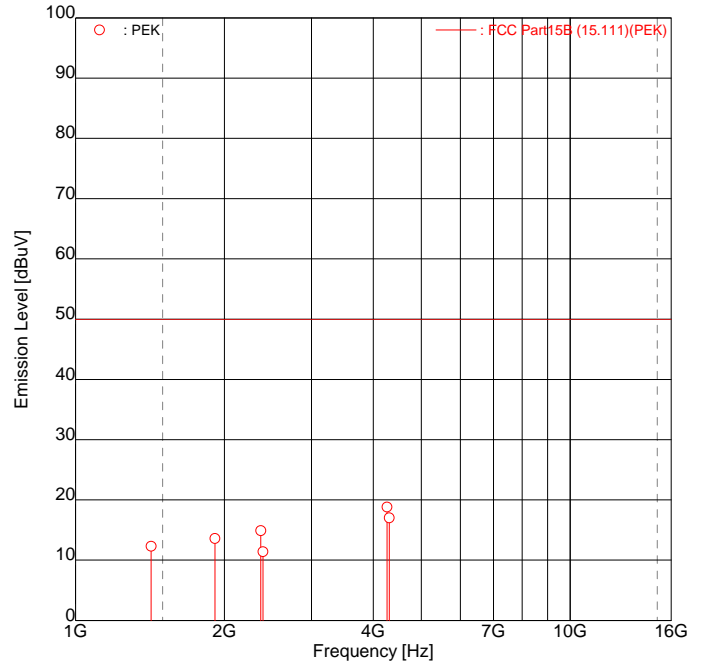

ENGINEER : Koichi Wagatsuma

FREQUENCY [No]	FREQUENCY [MHz]	READING [dBuV]	FACTOR [dB]	EMISSION [dBuV]	LIMIT [dBuV]	MARGIN [dB]
1	1422.0710	<u>42.3</u>	-30.0	<u>12.3</u>	50.0	<u>37.7</u>
2	1915.4390	<u>43.1</u>	-29.5	<u>13.6</u>	50.0	<u>36.4</u>
3	2369.9950	<u>44.5</u>	-29.6	<u>14.9</u>	50.0	<u>35.1</u>
4	2394.6250	<u>41.0</u>	-29.6	<u>11.4</u>	50.0	<u>38.6</u>
5	4265.9250	<u>46.0</u>	-27.2	<u>18.8</u>	50.0	<u>31.2</u>
6	4310.1060	<u>44.1</u>	-27.1	<u>17.0</u>	50.0	<u>33.0</u>

Higher six points are underlined.
 Other frequencies : Below the FCC Part15B (15.111) limit
 Emission Level = Read + Factor(Pad, Cable, Preamp)
 Limit : 2nW = 50dBuV(50ohm impedance)

**9.1.3.4 RX mode (A Band :118.05MHz/B Band :800.05MHz)
 30 - 1000MHz**

Intertek Japan K.K.
Kashima No.3 Test Site
 Conducted Power on Antenna Port

APPLICANT : JVC KENWOOD Corporation
 EUT NAME : 144/440MHz FM DUAL BANDER
 MODEL NO. : TM-D710GA
 SERIAL NO. : B3600176
 TEST MODE : RX mode (A Band:118.05MHz/B
 Band:800.05MHz)
 POWER SOURCE : DC 13.8V (AC 120V, 60Hz)
 DATE TESTED : Jul 31 2013
 FILE NO. : -
 REGULATION : FCC Part15B (15.111)
 TEST METHOD : ANSI C63.4-2003
 TEMPERATURE : 24.5 [degC]
 HUMIDITY : 51.0 [%]
 NOTE :

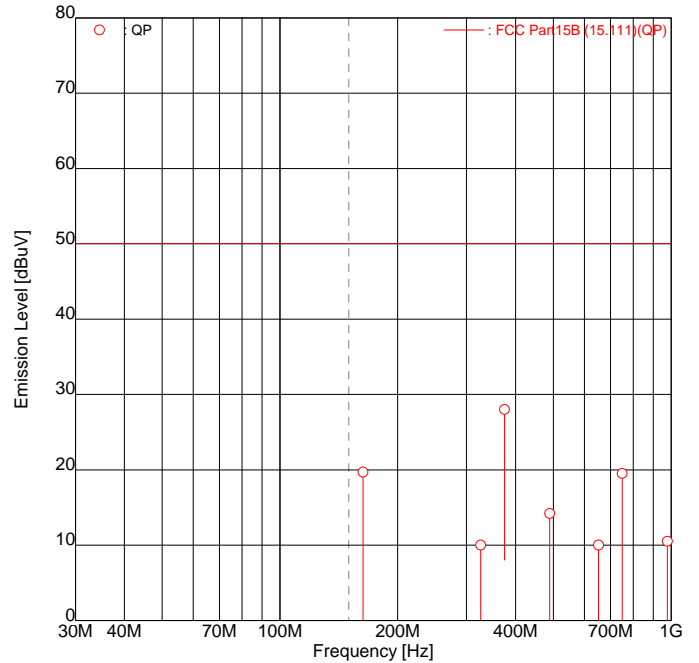

ENGINEER : Koichi Wagatsuma

FREQUENCY [No]	FREQUENCY [MHz]	READING [dBuV]	FACTOR [dB]	EMISSION [dBuV]	LIMIT [dBuV]	MARGIN [dB]
1	163.1073	<u>29.4</u>	-9.7	<u>19.7</u>	50.0	<u>30.3</u>
2	326.2011	<u>18.6</u>	-8.6	<u>10.0</u>	50.0	<u>40.0</u>
3	375.0584	<u>36.3</u>	-8.3	<u>28.0</u>	50.0	<u>22.0</u>
4	489.3013	<u>21.5</u>	-7.3	<u>14.2</u>	50.0	<u>35.8</u>
5	652.4011	<u>16.7</u>	-6.7	<u>10.0</u>	50.0	<u>40.0</u>
6	750.1012	<u>25.6</u>	-6.1	<u>19.5</u>	50.0	<u>30.5</u>
7	978.6005	<u>15.3</u>	-4.8	<u>10.5</u>	50.0	<u>39.5</u>

Higher six points are underlined.
 Other frequencies : Below the FCC Part15B (15.111) limit
 Emission Level = Read + Factor(Attenuator, Cable, Preamp)

1000 - 16000 MHz

Intertek Japan K.K.
Kashima No.3 Test Site
 Conducted Power on Antenna Port

APPLICANT : JVC KENWOOD Corporation
 EUT NAME : 144/440MHz FM DUAL BANDER
 MODEL NO. : TM-D710GA
 SERIAL NO. : B3600176
 TEST MODE : RX mode (A Band:118.05MHz/B
 Band:800.05MHz)
 POWER SOURCE : DC 13.8V (AC 120V, 60Hz)
 DATE TESTED : Aug 01 2013
 FILE NO. : -
 REGULATION : FCC Part15B (15.111)
 TEST METHOD : ANSI C63.4-2003
 TEMPERATURE : 24.0 [degC]
 HUMIDITY : 52.0 [%]
 NOTE :

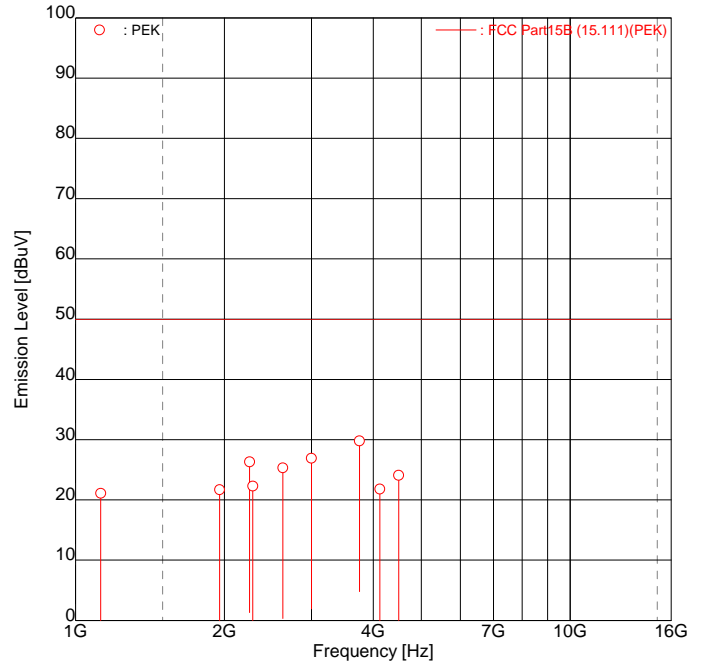

ENGINEER : Koichi Wagatsuma

FREQUENCY [No]	FREQUENCY [MHz]	READING [dBuV]	FACTOR [dB]	EMISSION [dBuV]	LIMIT [dBuV]	MARGIN [dB]
1	1125.1600	51.5	-30.4	21.1	50.0	28.9
2	1957.1500	51.1	-29.4	21.7	50.0	28.3
3	2250.2550	<u>55.8</u>	-29.5	<u>26.3</u>	50.0	<u>23.7</u>
4	2283.4150	<u>51.8</u>	-29.5	<u>22.3</u>	50.0	<u>27.7</u>
5	2625.3950	<u>54.9</u>	-29.6	<u>25.3</u>	50.0	<u>24.7</u>
6	3000.3950	<u>56.4</u>	-29.5	<u>26.9</u>	50.0	<u>23.1</u>
7	3750.4300	<u>58.0</u>	-28.2	<u>29.8</u>	50.0	<u>20.2</u>
8	4125.5740	49.2	-27.4	21.8	50.0	28.2
9	4500.4750	<u>50.9</u>	-26.8	<u>24.1</u>	50.0	<u>25.9</u>

Higher six points are underlined.
 Other frequencies : Below the FCC Part15B (15.111) limit
 Emission Level = Read + Factor(Pad, Cable, Preamp)
 Limit : 2nW = 50dBuV(50ohm impedance)

**9.1.3.5 RX mode (A Band :321.05MHz/B Band :1050.05MHz)
 30 - 1000MHz**

Intertek Japan K.K.
Kashima No.3 Test Site
 Conducted Power on Antenna Port

APPLICANT : JVC KENWOOD Corporation
 EUT NAME : 144/440MHz FM DUAL BANDER
 MODEL NO. : TM-D710GA
 SERIAL NO. : B3600176
 TEST MODE : RX mode (A Band:321.05MHz/B
 Band:1050.05MHz)
 POWER SOURCE : DC 13.8V (AC 120V, 60Hz)
 DATE TESTED : Jul 31 2013
 FILE NO. : -
 REGULATION : FCC Part15B (15.111)
 TEST METHOD : ANSI C63.4-2003
 TEMPERATURE : 24.5 [degC]
 HUMIDITY : 51.0 [%]
 NOTE :

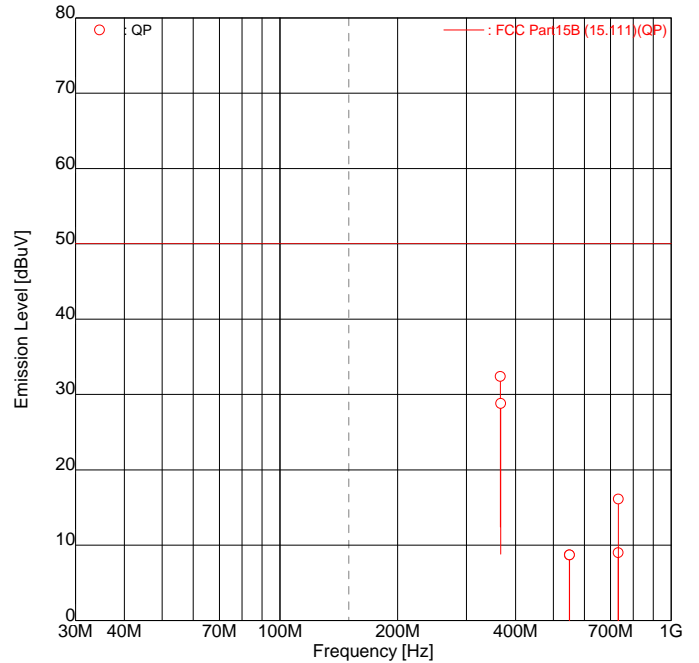

ENGINEER : Koichi Wagatsuma

FREQUENCY [No]	FREQUENCY [MHz]	READING [dBuV]	FACTOR [dB]	EMISSION [dBuV]	LIMIT [dBuV]	MARGIN [dB]
1	366.1007	<u>40.7</u>	-8.3	<u>32.4</u>	50.0	<u>17.6</u>
2	366.6700	<u>37.1</u>	-8.3	<u>28.8</u>	50.0	<u>21.2</u>
3	549.2081	<u>15.9</u>	-7.2	<u>8.7</u>	50.0	<u>41.3</u>
4	550.0962	<u>15.9</u>	-7.2	<u>8.7</u>	50.0	<u>41.3</u>
5	732.2000	<u>15.2</u>	-6.2	<u>9.0</u>	50.0	<u>41.0</u>
6	733.3334	<u>22.3</u>	-6.2	<u>16.1</u>	50.0	<u>33.9</u>

Higher six points are underlined.
 Other frequencies : Below the FCC Part15B (15.111) limit
 Emission Level = Read + Factor(Attenuator, Cable, Preamp)

1000 - 16000 MHz

Intertek Japan K.K.
Kashima No.3 Test Site
 Conducted Power on Antenna Port

APPLICANT : JVC KENWOOD Corporation
 EUT NAME : 144/440MHz FM DUAL BANDER
 MODEL NO. : TM-D710GA
 SERIAL NO. : B3600176
 TEST MODE : RX mode (A Band:321.05MHz/B
 Band:1050.05MHz)
 POWER SOURCE : DC 13.8V (AC 120V, 60Hz)
 DATE TESTED : Aug 01 2013
 FILE NO. : -
 REGULATION : FCC Part15B (15.111)
 TEST METHOD : ANSI C63.4-2003
 TEMPERATURE : 24.0 [degC]
 HUMIDITY : 52.0 [%]
 NOTE :

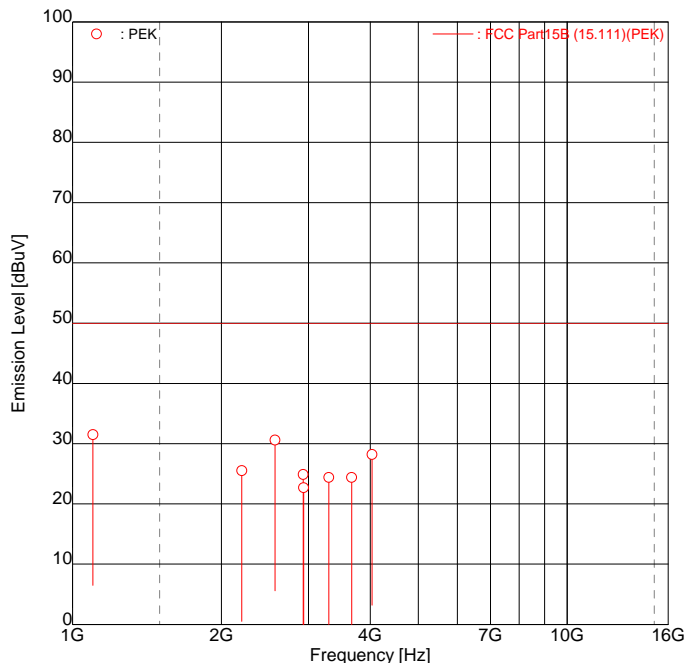

ENGINEER : Koichi Wagatsuma

FREQUENCY [No]	FREQUENCY [MHz]	READING [dBuV]	FACTOR [dB]	EMISSION [dBuV]	LIMIT [dBuV]	MARGIN [dB]
1	1100.0150	<u>62.0</u>	-30.5	<u>31.5</u>	50.0	18.5
2	2199.9310	<u>55.0</u>	-29.5	<u>25.5</u>	50.0	<u>24.5</u>
3	2566.6580	<u>60.2</u>	-29.6	<u>30.6</u>	50.0	<u>19.4</u>
4	2928.8340	<u>54.4</u>	-29.5	<u>24.9</u>	50.0	<u>25.1</u>
5	2933.3960	52.2	-29.5	22.7	50.0	27.3
6	3299.9990	<u>53.5</u>	-29.1	<u>24.4</u>	50.0	<u>25.6</u>
7	3666.6440	<u>52.8</u>	-28.4	<u>24.4</u>	50.0	<u>25.6</u>
8	4033.3420	<u>55.7</u>	-27.5	<u>28.2</u>	50.0	<u>21.8</u>

Higher six points are underlined.
 Other frequencies : Below the FCC Part15B (15.111) limit
 Emission Level = Read + Factor(Pad, Cable, Preamp)
 Limit : 2nW = 50dBuV(50ohm impedance)

**9.1.3.6 RX mode (A Band :523.95MHz/B Band :1299.95MHz)
 30 - 1000MHz**

Intertek Japan K.K.
Kashima No.3 Test Site
 Conducted Power on Antenna Port

APPLICANT : JVC KENWOOD Corporation
 EUT NAME : 144/440MHz FM DUAL BANDER
 MODEL NO. : TM-D710GA
 SERIAL NO. : B3600176
 TEST MODE : RX mode (A Band:523.95MHz/B
 Band:1299.95MHz)
 POWER SOURCE : DC 13.8V (AC 120V, 60Hz)
 DATE TESTED : Jul 31 2013
 FILE NO. : -
 REGULATION : FCC Part15B (15.111)
 TEST METHOD : ANSI C63.4-2003
 TEMPERATURE : 24.5 [degC]
 HUMIDITY : 51.0 [%]
 NOTE :

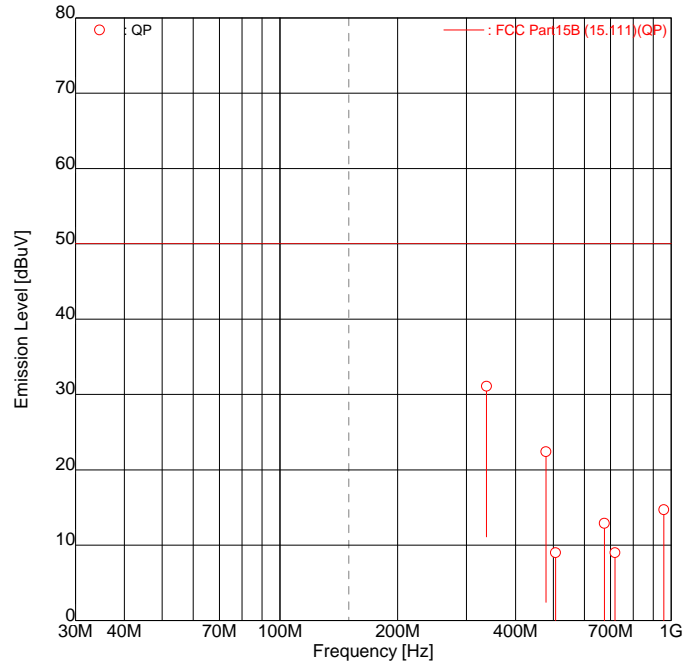

ENGINEER : Katsuya Uchida

FREQUENCY [No]	FREQUENCY [MHz]	READING [dBuV]	FACTOR [dB]	EMISSION [dBuV]	LIMIT [dBuV]	MARGIN [dB]
1	337.4745	<u>39.6</u>	-8.5	<u>31.1</u>	50.0	<u>18.9</u>
2	478.9100	<u>29.8</u>	-7.4	<u>22.4</u>	50.0	<u>27.6</u>
3	506.2127	<u>16.2</u>	-7.2	<u>9.0</u>	50.0	<u>41.0</u>
4	718.3597	<u>15.3</u>	-6.3	<u>9.0</u>	50.0	<u>41.0</u>
5	674.9500	<u>19.5</u>	-6.6	<u>12.9</u>	50.0	<u>37.1</u>
6	957.8147	<u>19.6</u>	-4.9	<u>14.7</u>	50.0	<u>35.3</u>

Higher six points are underlined.
 Other frequencies : Below the FCC Part15B (15.111) limit
 Emission Level = Read + Factor(Attenuator, Cable, Preamp)

1000 - 16000 MHz

Intertek Japan K.K.
Kashima No.3 Test Site
 Conducted Power on Antenna Port

APPLICANT : JVC KENWOOD Corporation
 EUT NAME : 144/440MHz FM DUAL BANDER
 MODEL NO. : TM-D710GA
 SERIAL NO. : B3600176
 TEST MODE : RX mode (A Band:523.95MHz/B
 Band:1299.95MHz)
 POWER SOURCE : DC 13.8V (AC 120V, 60Hz)
 DATE TESTED : Aug 01 2013
 FILE NO. : -
 REGULATION : FCC Part15B (15.111)
 TEST METHOD : ANSI C63.4-2003
 TEMPERATURE : 24.0 [degC]
 HUMIDITY : 52.0 [%]
 NOTE :

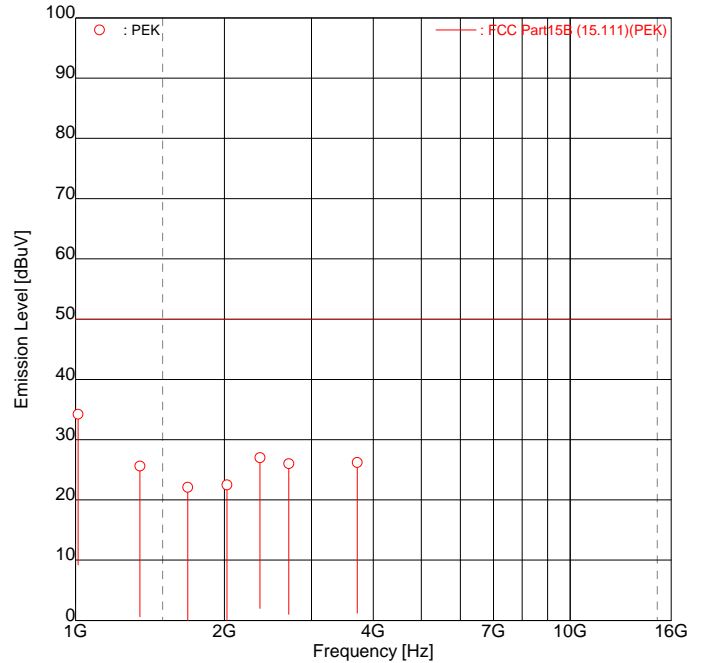

ENGINEER : Koichi Wagatsuma

FREQUENCY [No]	FREQUENCY [MHz]	READING [dBuV]	FACTOR [dB]	EMISSION [dBuV]	LIMIT [dBuV]	MARGIN [dB]
1	1012.4650	<u>64.8</u>	-30.6	<u>34.2</u>	50.0	15.8
2	1349.9450	<u>55.7</u>	-30.1	<u>25.6</u>	50.0	<u>24.4</u>
3	1687.2750	51.8	-29.7	22.1	50.0	27.9
4	2024.8800	<u>51.9</u>	-29.4	<u>22.5</u>	50.0	<u>27.5</u>
5	2362.2550	<u>56.6</u>	-29.6	<u>27.0</u>	50.0	<u>23.0</u>
6	2699.8050	<u>55.6</u>	-29.6	<u>26.0</u>	50.0	<u>24.0</u>
7	3712.2350	<u>54.5</u>	-28.3	<u>26.2</u>	50.0	<u>23.8</u>

Higher six points are underlined.
 Other frequencies : Below the FCC Part15B (15.111) limit
 Emission Level = Read + Factor(Pad, Cable, Preamp)
 Limit : 2nW = 50dBuV(50ohm impedance)

**9.1.3.7 VFO SCAN mode(A Band :144MHz Band/B Band : 144MHz Band)
 30 - 1000MHz**

< Graph number #1 >

SPECTRUM ANALYSIS

Kashima No.3 Test Site

Date tested : Jul 31 2013

Test mode : VFO Scan mode (A Band:144MHz
 Band/B Band:144MHz Band) 24.5degC /51.0%

Company : JVC KENWOOD Corporation
 EUT Name : 144/440MHz FM DUAL BANDER
 Model number : TM-D710GA
 Serial number : B3600176

Power source : DC 13.8V (AC 120V, 60Hz)
 File number : -
 Engineer : Katsuya Uchida
 Note : A Band : 136.00MHz - 199.995MHz
 B Band : 136.00MHz - 199.995MHz

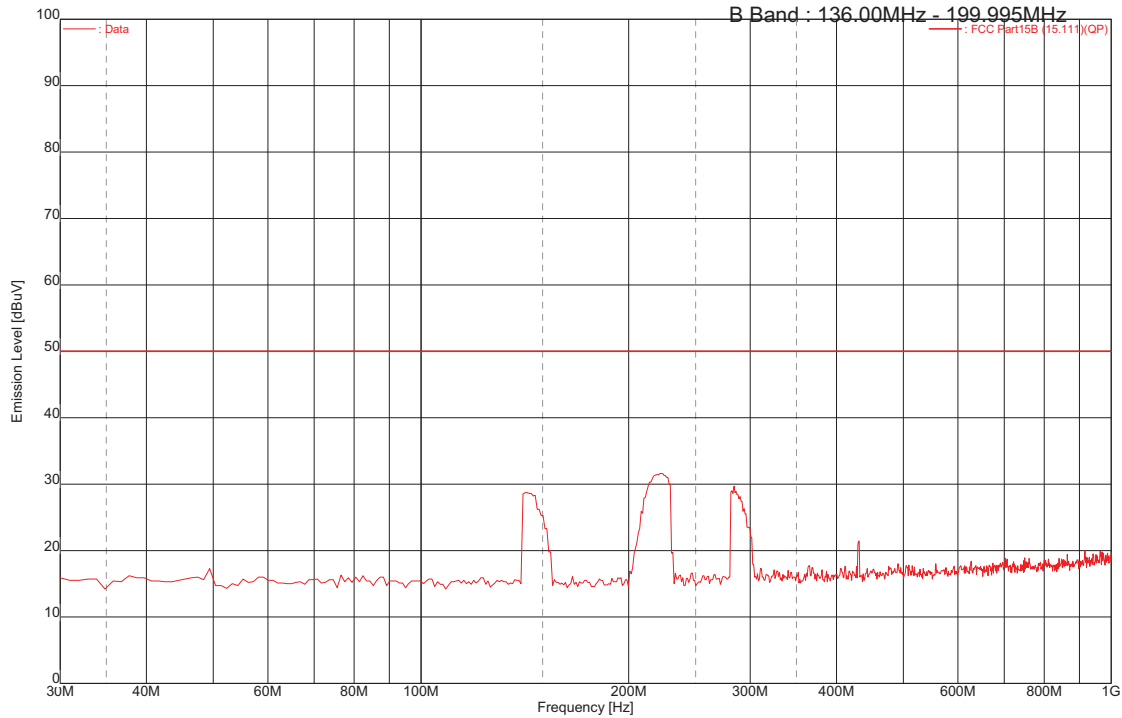

Frequency [MHz]	Reading [dBuV]	Factor [dB]	Emission [dBuV]	Limit [dBuV]	Margin [dB]
141.0500	<u>41.9</u>	-9.9	<u>32.0</u>	50.0	<u>18.0</u>
185.9595	<u>32.9</u>	-9.6	<u>23.3</u>	50.0	<u>26.7</u>
222.2556	<u>45.9</u>	-9.3	<u>36.6</u>	50.0	<u>13.4</u>
283.5087	<u>43.0</u>	-8.8	<u>34.2</u>	50.0	<u>15.8</u>
425.7049	<u>27.6</u>	-7.8	<u>19.8</u>	50.0	<u>30.2</u>
457.7095	<u>22.9</u>	-7.5	<u>15.4</u>	50.0	<u>34.6</u>

Higher six points are underlined.

Other frequencies : Below the FCC Part15B (15.111) limit
 Emission Level = Read + Factor (Attenuator, Cable, Preamp)
 Limit : 2nW = 50dBuV (50ohm impedance)

1000 - 16000 MHz

< Graph number #1 >

SPECTRUM ANALYSIS

Kashima No.3 Test Site

Date tested : Aug 01 2013

Test mode : VFO Scan mode (A Band:144MHz
 Band/B Band:144MHz Band) 24.0degC /52.0%

Company : JVC KENWOOD Corporation
 EUT Name : 144/440MHz FM DUAL BANDER
 Model number : TM-D710GA
 Serial number : B3600176

Power source : DC 13.8V (AC 120V, 60Hz)
 File number : -
 Engineer : Koichi Wagatsuma
 Note : A Band : 136.00MHz - 199.995MHz
 B Band : 136.00MHz - 199.995MHz

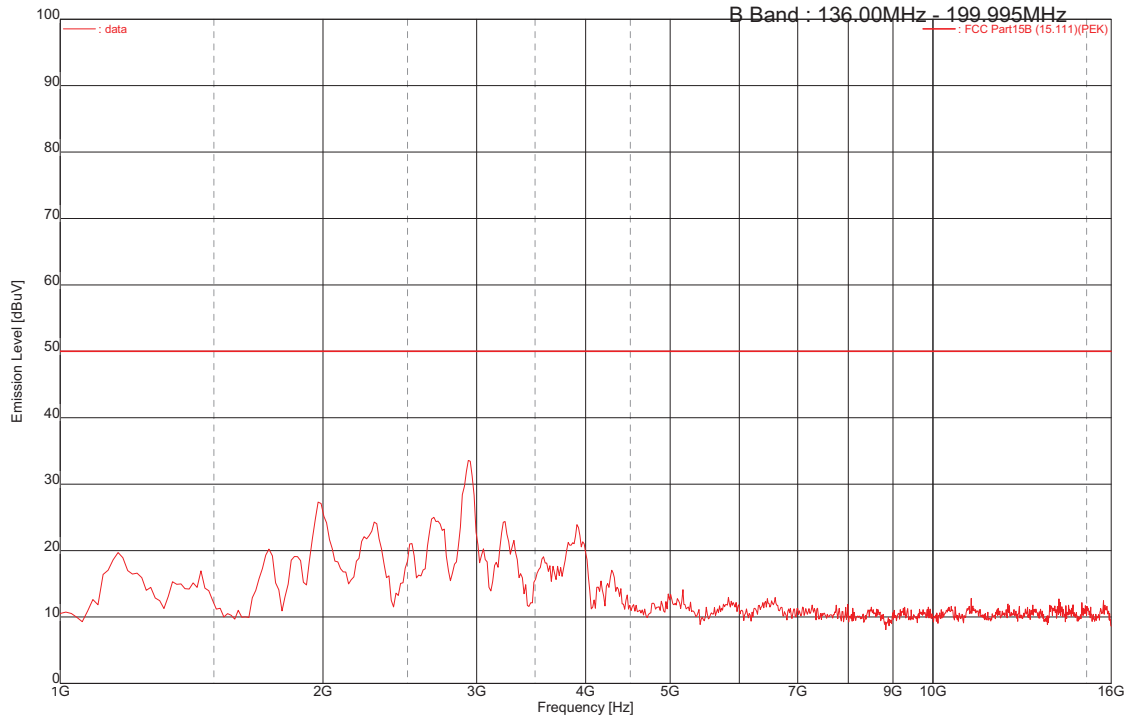

Frequency [MHz]	Reading [dBuV]	Factor [dB]	Emission [dBuV]	Limit [dBuV]	Margin [dB]
1974.9600	<u>59.7</u>	-29.4	<u>30.3</u>	50.0	<u>19.7</u>
2297.3600	<u>57.9</u>	-29.5	<u>28.4</u>	50.0	<u>21.6</u>
2680.1950	<u>57.9</u>	-29.6	<u>28.3</u>	50.0	<u>21.7</u>
2934.7500	<u>64.6</u>	-29.5	<u>35.1</u>	50.0	<u>14.9</u>
3228.0050	<u>59.2</u>	-29.2	<u>30.0</u>	50.0	<u>20.0</u>
3915.0050	<u>53.3</u>	-27.8	<u>25.5</u>	50.0	<u>24.5</u>

Higher six points are underlined.

Other frequencies : Below the FCC Part15B (15.111) limit
 Emission Level = Read + Factor (Attenuator, Cable, Preamp)
 Limit : 2nW = 50dBuV (50ohm impedance)

**9.1.3.8 VFO SCAN mode(A Band :220MHz Band/B Band : 220MHz Band)
 30 - 1000MHz**

< Graph number #1 >

SPECTRUM ANALYSIS

Kashima No.3 Test Site

Date tested : Jul 31 2013

Test mode : VFO Scan mode (A Band:220MHz
 Band/B Band:220MHz Band) 24.5degC /51.0%

Company : JVC KENWOOD Corporation
 EUT Name : 144/440MHz FM DUAL BANDER
 Model number : TM-D710GA
 Serial number : B3600176

Power source : DC 13.8V (AC 120V, 60Hz)
 File number : -
 Engineer : Katsuya Uchida
 Note : A Band : 200.00MHz - 299.995MHz
 B Band : 200.00MHz - 299.995MHz

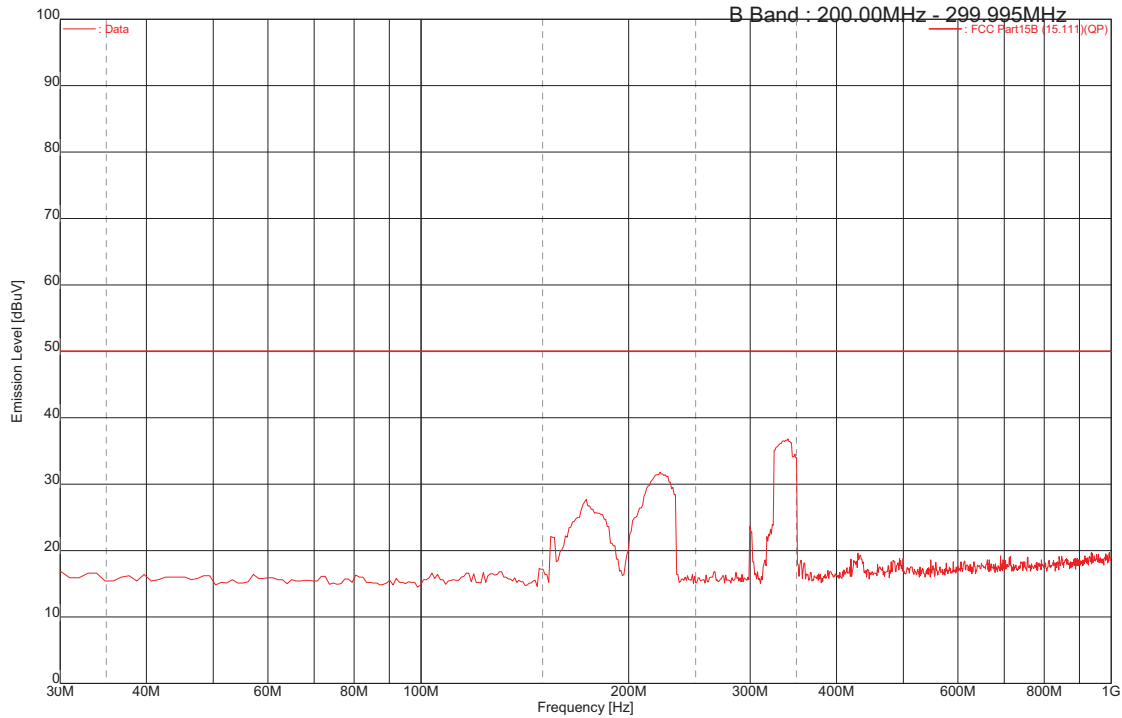

Frequency [MHz]	Reading [dBuV]	Factor [dB]	Emission [dBuV]	Limit [dBuV]	Margin [dB]
174.9567	<u>40.2</u>	-9.7	<u>30.5</u>	50.0	<u>19.5</u>
225.3596	<u>44.5</u>	-9.3	<u>35.2</u>	50.0	<u>14.8</u>
300.3025	<u>33.0</u>	-8.7	<u>24.3</u>	50.0	<u>25.7</u>
341.1083	<u>46.5</u>	-8.4	<u>38.1</u>	50.0	<u>11.9</u>
426.5070	<u>25.9</u>	-7.8	<u>18.1</u>	50.0	<u>31.9</u>
488.8640	<u>27.6</u>	-7.3	<u>20.3</u>	50.0	<u>29.7</u>

Higher six points are underlined.

Other frequencies : Below the FCC Part15B (15.111) limit
 Emission Level = Read + Factor (Attenuator, Cable, Preamp)
 Limit : 2nW = 50dBuV (50ohm impedance)

1000 - 16000 MHz

< Graph number #1 >

SPECTRUM ANALYSIS

Kashima No.3 Test Site

Date tested : Aug 01 2013

Test mode : VFO Scan mode (A Band:220MHz
 Band/B Band:220MHz Band) 24.0degC /52.0%

Company : JVC KENWOOD Corporation
 EUT Name : 144/440MHz FM DUAL BANDER
 Model number : TM-D710GA
 Serial number : B3600176

Power source : DC 13.8V (AC 120V, 60Hz)
 File number : -
 Engineer : Koichi Wagatsuma
 Note : A Band : 200.00MHz - 299.995MHz
 B Band : 200.00MHz - 299.995MHz

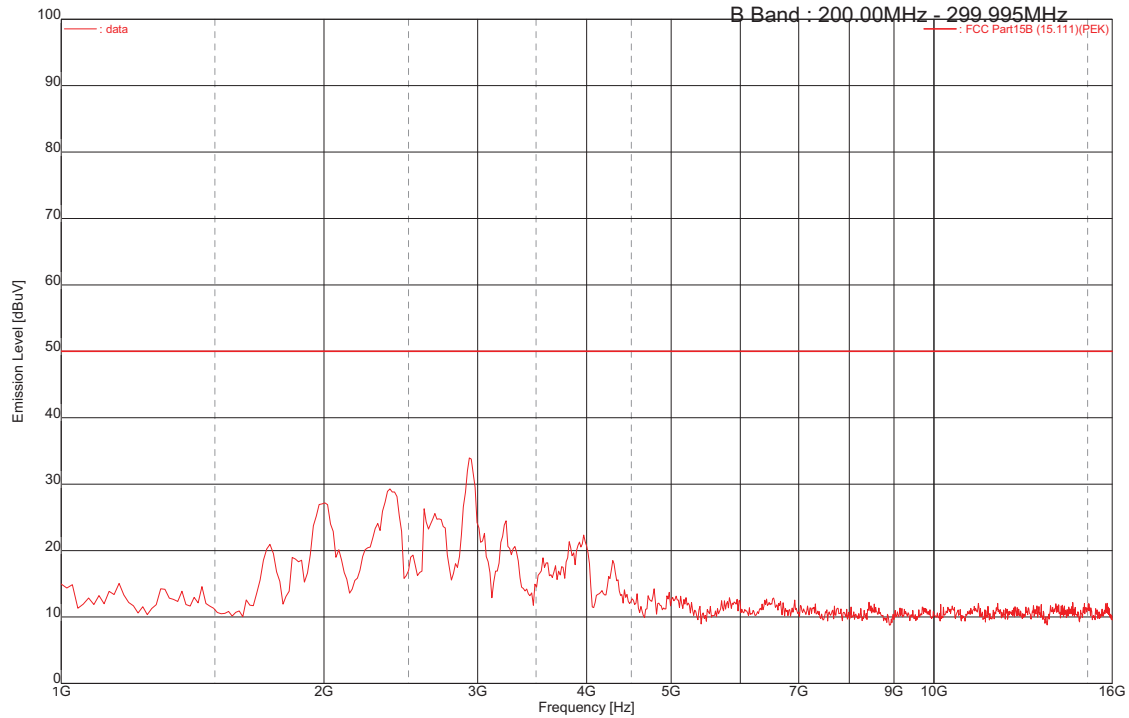

Frequency [MHz]	Reading [dBuV]	Factor [dB]	Emission [dBuV]	Limit [dBuV]	Margin [dB]
1977.6600	<u>59.6</u>	-29.4	<u>30.2</u>	50.0	<u>19.8</u>
2008.5700	<u>59.6</u>	-29.4	<u>30.2</u>	50.0	<u>19.8</u>
2376.8050	<u>60.1</u>	-29.6	<u>30.5</u>	50.0	<u>19.5</u>
2600.5300	<u>57.8</u>	-29.6	<u>28.2</u>	50.0	<u>21.8</u>
2679.0100	<u>58.5</u>	-29.6	<u>28.9</u>	50.0	<u>21.1</u>
2936.0700	<u>65.2</u>	-29.5	<u>35.7</u>	50.0	<u>14.3</u>

Higher six points are underlined.

Other frequencies : Below the FCC Part15B (15.111) limit
 Emission Level = Read + Factor (Attenuator, Cable, Preamp)

Limit : 2nW = 50dBuV (50ohm impedance)

**9.1.3.9 VFO SCAN mode(A Band :300MHz Band/B Band : 300MHz Band)
 30 - 1000MHz**

< Graph number #1 >

SPECTRUM ANALYSIS

Kashima No.3 Test Site

Date tested : Jul 31 2013

Test mode : VFO Scan mode (A Band:300MHz
 Band/B Band:300MHz Band) 24.5degC /51.0%

Company : JVC KENWOOD Corporation
 EUT Name : 144/440MHz FM DUAL BANDER
 Model number : TM-D710GA
 Serial number : B3600176

Power source : DC 13.8V (AC 120V, 60Hz)
 File number : -
 Engineer : Katsuya Uchida
 Note : A Band : 300.00MHz - 399.995MHz
 B Band : 300.00MHz - 399.995MHz

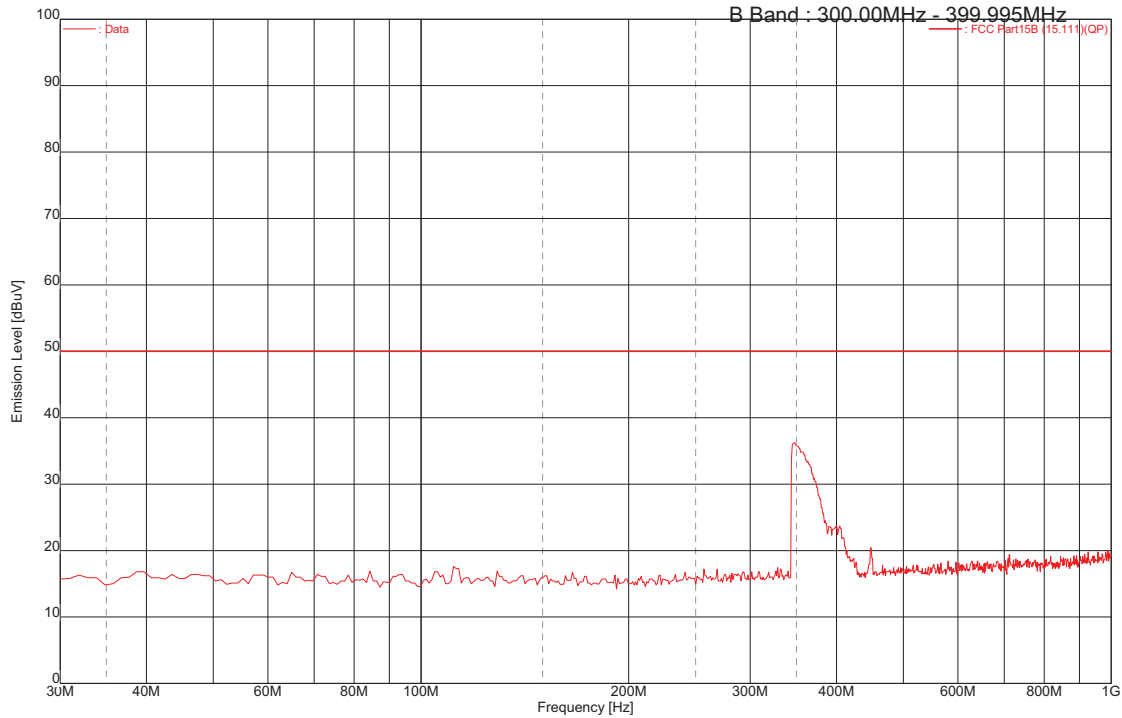

Frequency [MHz]	Reading [dBuV]	Factor [dB]	Emission [dBuV]	Limit [dBuV]	Margin [dB]
345.0585	<u>45.0</u>	-8.4	<u>36.6</u>	50.0	<u>13.4</u>
349.9558	<u>48.6</u>	-8.4	<u>40.2</u>	50.0	<u>9.8</u>
385.7462	<u>35.7</u>	-8.1	<u>27.6</u>	50.0	<u>22.4</u>
402.6503	<u>34.0</u>	-8.1	<u>25.9</u>	50.0	<u>24.1</u>
419.1560	<u>26.7</u>	-7.9	<u>18.8</u>	50.0	<u>31.2</u>
444.9523	<u>21.3</u>	-7.6	<u>13.7</u>	50.0	<u>36.3</u>

Higher six points are underlined.

Other frequencies : Below the FCC Part15B (15.111) limit

Emission Level = Read + Factor (Attenuator, Cable, Preamp)

Limit : 2nW = 50dBuV (50ohm impedance)

1000 - 16000 MHz

< Graph number #1 >

SPECTRUM ANALYSIS

Kashima No.3 Test Site

Date tested : Aug 01 2013

Test mode : VFO Scan mode (A Band:300MHz

Band/B Band:300MHz Band)

Company : JVC KENWOOD Corporation
 EUT Name : 144/440MHz FM DUAL BANDER
 Model number : TM-D710GA
 Serial number : B3600176

Power source : DC 13.8V (AC 120V, 60Hz)

File number : -

Engineer : Koichi Wagatsuma

Note : A Band : 300.00MHz - 399.995MHz

B Band : 300.00MHz - 399.995MHz

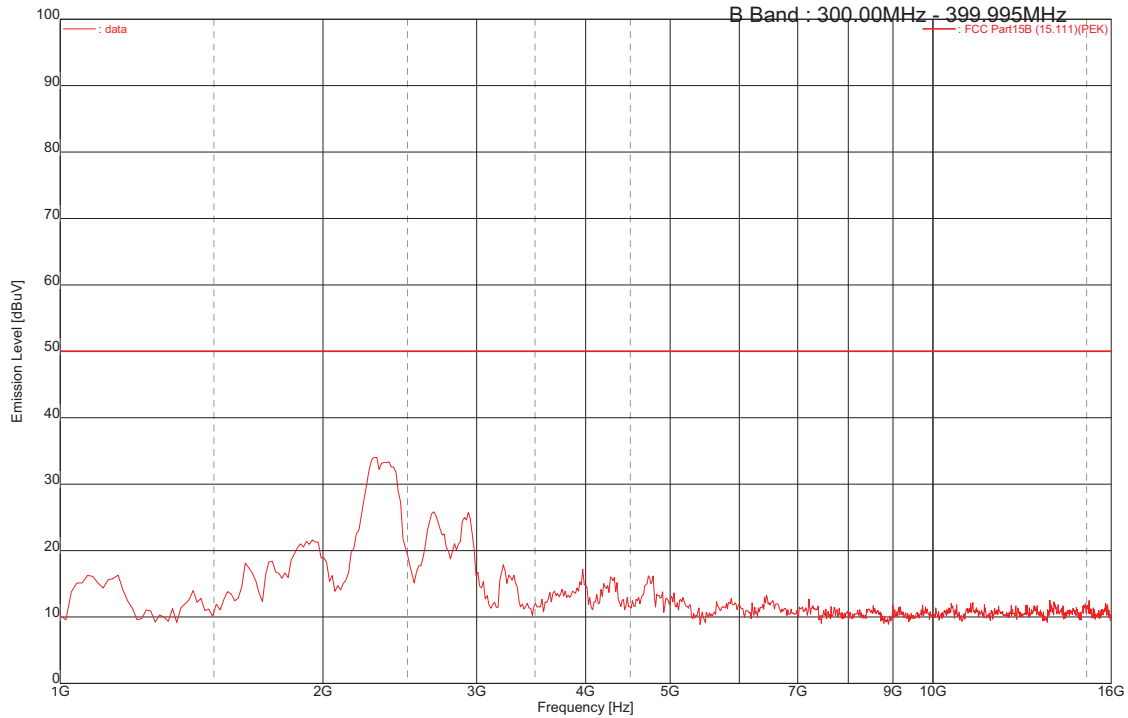

Frequency [MHz]	Reading [dBuV]	Factor [dB]	Emission [dBuV]	Limit [dBuV]	Margin [dB]
1910.2650	<u>55.3</u>	-29.5	<u>25.8</u>	50.0	<u>24.2</u>
1942.7500	<u>56.1</u>	-29.5	<u>26.6</u>	50.0	<u>23.4</u>
2290.4900	<u>64.5</u>	-29.5	<u>35.0</u>	50.0	<u>15.0</u>
2371.5350	<u>64.2</u>	-29.6	<u>34.6</u>	50.0	<u>15.4</u>
2678.4600	<u>56.3</u>	-29.6	<u>26.7</u>	50.0	<u>23.3</u>
2934.7200	<u>58.4</u>	-29.5	<u>28.9</u>	50.0	<u>21.1</u>

Higher six points are underlined.

Other frequencies : Below the FCC Part15B (15.111) limit

Emission Level = Read + Factor (Attenuator, Cable, Preamp)

Limit : 2nW = 50dBuV (50ohm impedance)

**9.1.3.10 VFO SCAN mode(A Band :430MHz Band/B Band : 430MHz Band)
 30 - 1000MHz**

< Graph number #1 >

SPECTRUM ANALYSIS

Kashima No.3 Test Site

Date tested : Jul 31 2013

Test mode : VFO Scan mode (A Band:430MHz
 Band/B Band:430MHz Band) 24.5degC /51.0%

Company : JVC KENWOOD Corporation
 EUT Name : 144/440MHz FM DUAL BANDER
 Model number : TM-D710GA
 Serial number : B3600176

Power source : DC 13.8V (AC 120V, 60Hz)
 File number : -
 Engineer : Katsuya Uchida
 Note : A Band : 400.00MHz - 523.995MHz
 B Band : 400.00MHz - 523.995MHz

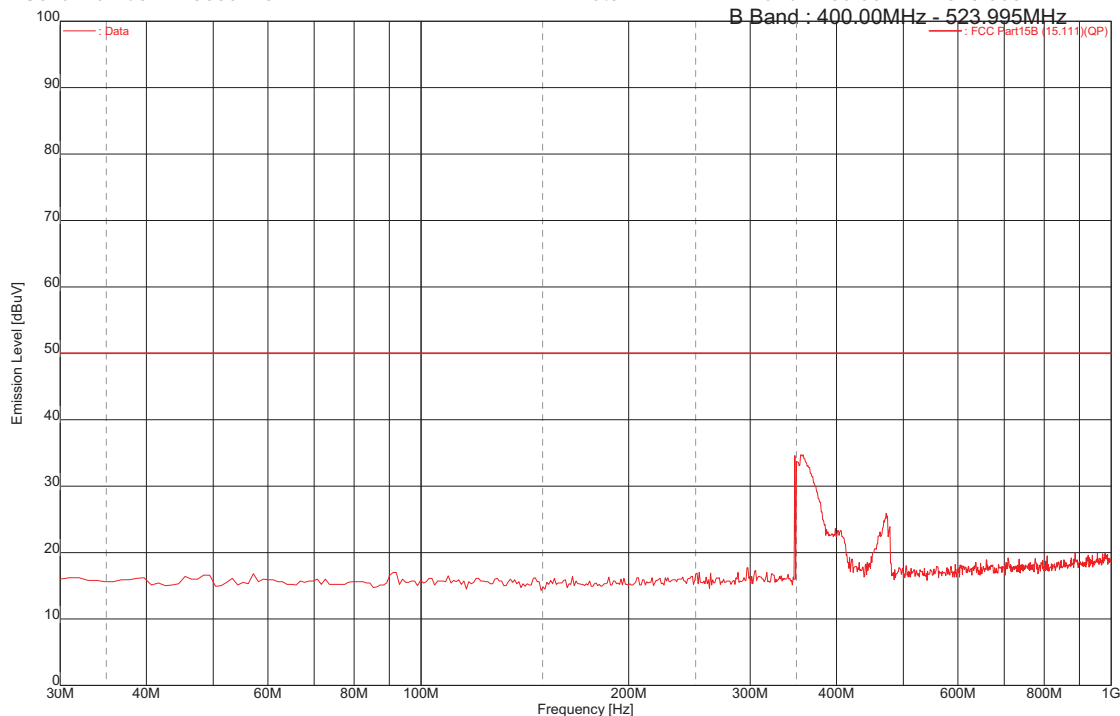

Frequency [MHz]	Reading [dBuV]	Factor [dB]	Emission [dBuV]	Limit [dBuV]	Margin [dB]
350.0503	<u>42.4</u>	-8.4	<u>34.0</u>	50.0	<u>16.0</u>
354.9600	<u>47.4</u>	-8.4	<u>39.0</u>	50.0	<u>11.0</u>
384.9460	<u>35.4</u>	-8.2	<u>27.2</u>	50.0	<u>22.8</u>
405.2560	<u>33.8</u>	-8.0	<u>25.8</u>	50.0	<u>24.2</u>
473.8585	<u>36.8</u>	-7.4	<u>29.4</u>	50.0	<u>20.6</u>
478.8572	<u>30.9</u>	-7.4	<u>23.5</u>	50.0	<u>26.5</u>

Higher six points are underlined.

Other frequencies : Below the FCC Part15B (15.111) limit
 Emission Level = Read + Factor (Attenuator, Cable, Preamp)

Limit : 2nW = 50dBuV (50ohm impedance)

1000 - 16000 MHz

< Graph number #1 >

SPECTRUM ANALYSIS

Kashima No.3 Test Site

Date tested : Aug 01 2013

Test mode : VFO Scan mode (A Band:430MHz
 Band/B Band:430MHz Band) 24.0degC /52.0%

Company : JVC KENWOOD Corporation
 EUT Name : 144/440MHz FM DUAL BANDER
 Model number : TM-D710GA
 Serial number : B3600176

Power source : DC 13.8V (AC 120V, 60Hz)
 File number : -
 Engineer : Koichi Wagatsuma
 Note : A Band : 400.00MHz - 523.995MHz
 B Band : 400.00MHz - 523.995MHz

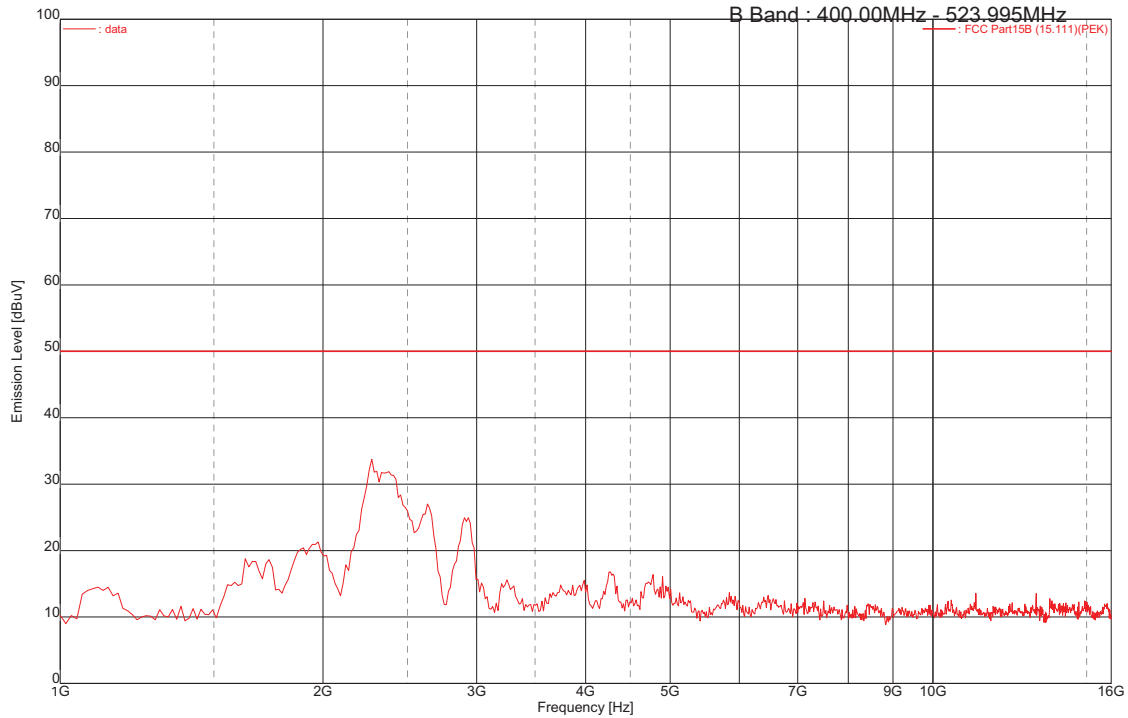

Frequency [MHz]	Reading [dBuV]	Factor [dB]	Emission [dBuV]	Limit [dBuV]	Margin [dB]
1885.1950	<u>54.3</u>	-29.5	<u>24.8</u>	50.0	<u>25.2</u>
1959.7000	<u>54.1</u>	-29.4	<u>24.7</u>	50.0	<u>25.3</u>
2279.7100	<u>65.3</u>	-29.5	<u>35.8</u>	50.0	<u>14.2</u>
2343.3050	<u>62.3</u>	-29.6	<u>32.7</u>	50.0	<u>17.3</u>
2645.7000	<u>61.1</u>	-29.6	<u>31.5</u>	50.0	<u>18.5</u>
2933.9050	<u>56.9</u>	-29.5	<u>27.4</u>	50.0	<u>22.6</u>

Higher six points are underlined.

Other frequencies : Below the FCC Part15B (15.111) limit
 Emission Level = Read + Factor (Attenuator, Cable, Preamp)
 Limit : 2nW = 50dBuV (50ohm impedance)

**9.1.3.11 VFO SCAN mode(A Band :118MHz Band/B Band : 1200MHz Band)
 30 - 1000MHz**

< Graph number #1 >

SPECTRUM ANALYSIS

Kashima No.3 Test Site

Date tested : Jul 31 2013

Test mode : VFO Scan mode (A Band:118MHz
 Band/B Band:1200MHz Band) 24.5degC /51.0%

Company : JVC KENWOOD Corporation
 EUT Name : 144/440MHz FM DUAL BANDER
 Model number : TM-D710GA
 Serial number : B3600176

Power source : DC 13.8V (AC 120V, 60Hz)
 File number : -
 Engineer : Katsuya Uchida
 Note : A Band : 118.00MHz - 135.995MHz
 B Band : 800.00MHz - 1299.990MHz

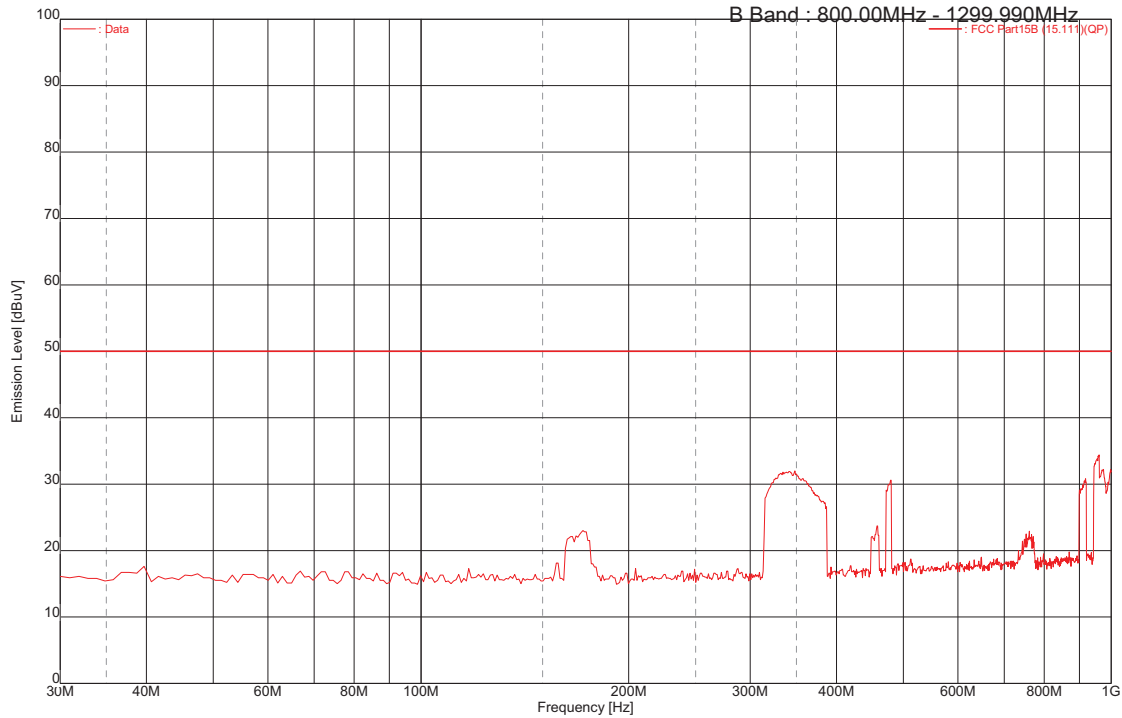

Frequency [MHz]	Reading [dBuV]	Factor [dB]	Emission [dBuV]	Limit [dBuV]	Margin [dB]
172.2605	<u>31.6</u>	-9.7	<u>21.9</u>	50.0	<u>28.1</u>
339.7839	<u>40.8</u>	-8.4	<u>32.4</u>	50.0	<u>17.6</u>
479.9347	<u>38.2</u>	-7.4	<u>30.8</u>	50.0	<u>19.2</u>
918.8500	<u>35.3</u>	-5.1	<u>30.2</u>	50.0	<u>19.8</u>
959.8520	<u>38.9</u>	-4.9	<u>34.0</u>	50.0	<u>16.0</u>
1000.0000	<u>36.2</u>	-4.6	<u>31.6</u>	50.0	<u>18.4</u>

Higher six points are underlined.

Other frequencies : Below the FCC Part15B (15.111) limit
 Emission Level = Read + Factor (Attenuator, Cable, Preamp)
 Limit : 2nW = 50dBuV (50ohm impedance)

1000 - 16000 MHz

< Graph number #1 >

SPECTRUM ANALYSIS

Kashima No.3 Test Site

Date tested : Aug 02 2013

Test mode : VFO Scan mode (A Band:118MHz
 Band/B Band:1200MHz Band) 24.8degC /60.0%

Company : JVC KENWOOD Corporation
 EUT Name : 144/440MHz FM DUAL BANDER
 Model number : TM-D710GA
 Serial number : B3600176

Power source : DC 13.8V (AC 120V, 60Hz)
 File number : -
 Engineer : Koichi Wagatsuma
 Note : A Band : 118.00MHz - 135.995MHz
 B Band : 800.00MHz - 1299.990MHz

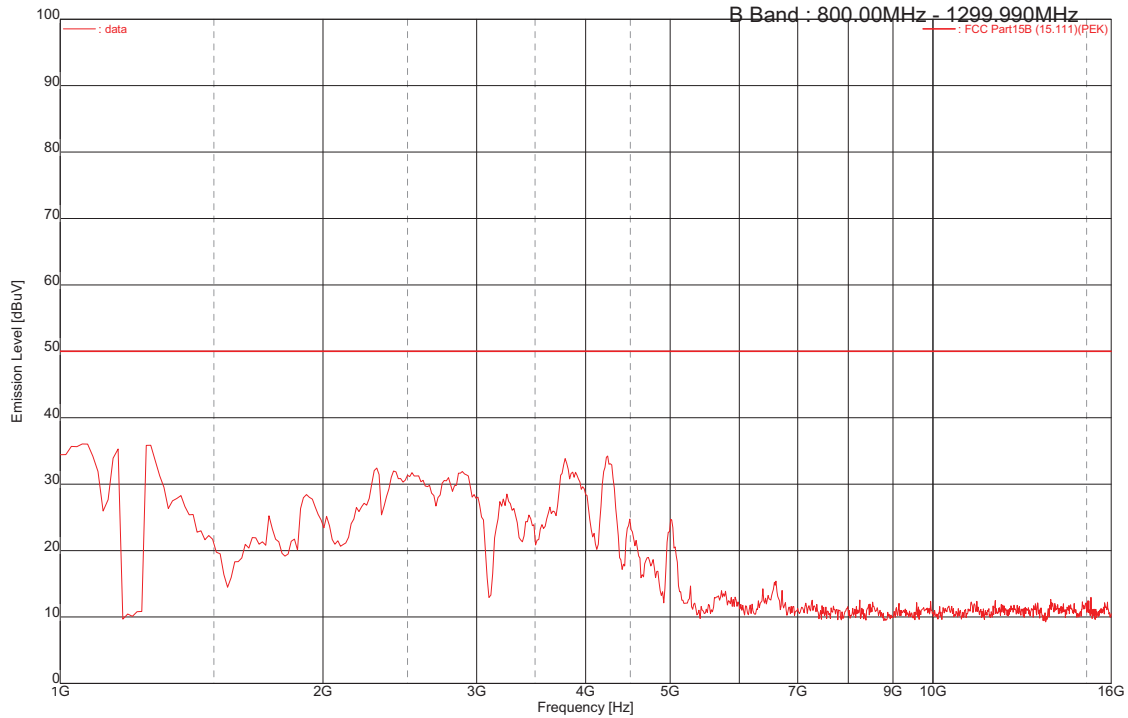

Frequency [MHz]	Reading [dBuV]	Factor [dB]	Emission [dBuV]	Limit [dBuV]	Margin [dB]
1034.5000	<u>66.3</u>	-30.5	<u>35.8</u>	50.0	<u>14.2</u>
1066.0000	<u>66.6</u>	-30.5	<u>36.1</u>	50.0	<u>13.9</u>
1159.8000	<u>65.4</u>	-30.4	<u>35.0</u>	50.0	<u>15.0</u>
1260.1000	<u>66.3</u>	-30.3	<u>36.0</u>	50.0	<u>14.0</u>
2300.8200	<u>63.6</u>	-29.5	<u>34.1</u>	50.0	<u>15.9</u>
2418.7000	61.8	-29.6	32.2	50.0	17.8
2935.1000	<u>63.5</u>	-29.5	<u>34.0</u>	50.0	<u>16.0</u>
3787.8000	60.5	-28.1	32.4	50.0	17.6
4235.4400	60.2	-27.2	33.0	50.0	17.0

Higher six points are underlined.
 Other frequencies : Below the FCC Part15B (15.111) limit
 Emission Level = Read + Factor (Attenuator, Cable, Preamp)
 Limit : 2nW = 50dBuV (50ohm impedance)

9.1.4 38dB Rejection Test

Location	Kashima No.3 Test Site
Date Tested	August 07, 2013 to August 19, 2013
Temperature	24.3 to 26.3 [degC]
Humidity	38 to 60 [%]
Test Engineer	Koichi Wagatsuma and Katsuya Uchida

Frequency Range of Measurements

Operating mode	Required Frequency Range	Measured Frequency Range
VFO SCAN mode (A Band : 118MHz-524MHz)	118 – 524 MHz	118 – 524 MHz
VFO SCAN mode (B Band : 136MHz-524MHz)	136 – 524 MHz	136 – 524 MHz
VFO SCAN mode (B Band : 800MHz-1300MHz)	800 – 1300 MHz	800 – 1300 MHz

Test Procedure

Item	Document number
38dB Rejection Test	RJP-TE102

9.1.4 Result of 38dB Rejection Test

9.1.4.1 VFO SCAN mode (A Band : 118MHz-524MHz)

Injected Frequency [MHz]	Detected Frequency [MHz]	12dB SINAD Reading Injected Frequency [dBm]	12dB SINAD Reading Detected Frequency [dBm]	Rejection Level [dB]	Margin [dB]
824.040	No Point Detected	See Note	See Note	-	-
836.505	No Point Detected	See Note	See Note	-	-
848.970	No Point Detected	See Note	See Note	-	-
869.040	No Point Detected	See Note	See Note	-	-
881.505	No Point Detected	See Note	See Note	-	-
893.970	No Point Detected	See Note	See Note	-	-

Note : There was no need to carry out the measurements because no point was detected.

SG Input Level = 66dBuV

SG Reference Level = -0.7dBuV (the worst case sensitivity)

9.1.4.2 VFO SCAN mode (B Band : 136MHz-524MHz)

Injected Frequency [MHz]	Detected Frequency [MHz]	12dB SINAD Reading Injected Frequency [dBm]	12dB SINAD Reading Detected Frequency [dBm]	Rejection Level [dB]	Margin [dB]
824.040	No Point Detected	See Note	See Note	-	-
836.505	No Point Detected	See Note	See Note	-	-
848.970	No Point Detected	See Note	See Note	-	-
869.040	No Point Detected	See Note	See Note	-	-
881.505	No Point Detected	See Note	See Note	-	-
893.970	No Point Detected	See Note	See Note	-	-

Note : There was no need to carry out the measurements because no point was detected.

SG Input Level = 66dBuV
 SG Reference Level = -1.3dBuV (the worst case sensitivity)

9.1.4.3 VFO SCAN mode (B Band : 800MHz-1300MHz)

Injected Frequency [MHz]	Detected Frequency [MHz]	12dB SINAD Reading Injected Frequency [dBm]	12dB SINAD Reading Detected Frequency [dBm]	Rejection Level [dB]	Margin [dB]
824.040	968.870	81.0	3.8	77.2	39.2
	1228.550	68.0	1.2	66.8	28.8
	1229.560	80.0	1.2	78.8	40.8
836.505	923.880	82.0	8.8	73.2	35.2
	923.890	75.1	9.0	66.1	28.1
	983.830	85.0	11.4	73.6	35.6
	1248.490	82.0	3.6	78.4	40.4
	1248.500	70.0	3.6	66.4	28.4
848.970	938.840	80.6	9.1	71.5	33.5
	998.780	75.7	11.7	64.0	26.0
	1268.440	63.2	3.3	59.9	21.9
869.040	1022.870	84.0	8.8	75.2	37.2
	1122.770	84.6	5.1	79.5	41.5
881.505	856.530	65.0	12.0	53.0	15.0
	977.880	83.0	6.7	76.3	38.3
	977.890	79.8	6.6	73.2	35.2
	1037.820	76.5	10.7	65.8	27.8
	1037.830	79.3	10.9	68.4	30.4
	1137.720	77.4	7.0	70.4	32.4
	1137.730	79.8	7.0	72.8	34.8
893.970	1052.780	74.7	10.7	64.0	26.0
	1152.680	74.4	12.9	61.5	23.5

SG Input Level = 66dBuV
 SG Reference Level = 12.9dBuV (the worst case sensitivity)

SECTION 10. LIST OF MEASURING INSTRUMENTS

Test instruments are calibrated according to Quality Manual and Calibration Rules of Intertek Japan K.K.

Instrument	Model No.	Serial No.	Manufacturer	Cal. Interval	Effective period
Conducted disturbance at mains terminals					
LISN(EUT)	ESH2-Z5	890484/001	Rohde & Schwarz	1Y	Nov. 30, 2013
LISN(Peripheral)	KNW-242	8-851-21	KYORITSU	1Y	Apr. 30, 2014
10dB LISN Pad	CFA-01	KSR00240	TME	1Y	Nov. 30, 2013
10dB LISN Pad	CFA-01	KSR00255	TME	1Y	Apr. 30, 2014
50 ohm Termination	CT-01	KSR00138	TME	1Y	Apr. 30, 2014
Coaxial Cable (C1)	RG-5A/U(7.2m)	C1	Intertek	1Y	Apr. 30, 2014
Coaxial Cable (C2)	RG-5A/U(4.0m)	C2	Intertek	1Y	Apr. 30, 2014
Coaxial Cable (R11)	RG-5A/U(1.1m)	R11	Intertek	1Y	Apr. 30, 2014
RF Switch	ACX-150	None	Intertek	1Y	Apr. 30, 2014
Radiated disturbance					
Antenna	VULB9168WP	288	Schwarzbeck	1Y	May 31, 2014
Amplifier	ZX60-3018G	005	Intertek	1Y	Jan. 31, 2014
6dB Attenuator	UFA-01	A00040805	TME	1Y	Jan. 31, 2014
Double ridged antenna	3115	5044	EMCO	1Y	Jul. 31, 2014
Amplifier	TPA0118-30	0402	TOYO	1Y	Oct. 31, 2013
3dB attenuator	6803.17.B	KSR00089	SUHNER	1Y	Oct. 31, 2013
Coaxial Cable (R1)	RG-5A/U(14.0m)	R1	Intertek	1Y	Jan. 31, 2014
Coaxial Cable (R3)	RG-5A/U(7.0m)	R3	Intertek	1Y	Jan. 31, 2014
Coaxial Cable (R5)	RG-5A/U(4.0m)	R5	Intertek	1Y	Jan. 31, 2014
Coaxial Cable (R7)	5D-2W(0.7m)	R7	Intertek	1Y	Jan. 31, 2014
Coaxial Cable (R10)	5D-2W(1.2m)	R10	Intertek	1Y	Jan. 31, 2014
RF Switch	ACX-150	None	Intertek	1Y	Jan. 31, 2014
Coaxial Cable (R14)	R286401343 (1.0m)	03 23 104	RADIALL	1Y	Oct. 31, 2013
Coaxial Cable (R15)	R286401344 (8.0m)	03 23 72	RADIALL	1Y	Oct. 31, 2013
Spectrum Analyzer	N9030A (Rev.A,08,54)	US51350170	Agilent	1Y	Jan. 31, 2014
Site Attenuation	-	-	-	1Y	Feb. 28, 2014
Common					
Test Receiver	ESS	842886/011	Rohde & Schwarz	1Y	Aug. 31, 2013
Test Receiver	ESS	847151/012	Rohde & Schwarz	1Y	Mar. 31, 2014
Testing software	emiT (Version 3,0,0,0)	-	-	-	-

Instrument	Model No.	Serial No.	Manufacturer	Cal. Interval	Effective period
Conducted power on antenna port					
3dB Attenuator	779	ATS015031	narda	1 Y	Oct. 31, 2013
10dB Attenuator	CFA-05NPJ-10	262856	TME	1 Y	Dec. 31, 2013
Step Attenuator	8494B	2406A09036	Hewlett Packard	1 Y	Jul. 31, 2014
Amplifier	TPA0118-30	0303	TOYO	1 Y	Oct. 31, 2013
Amplifier	ZX60-3018G	003	Intertek	1 Y	Jul. 31, 2014
Spectrum Analyzer	N9030A(Rev.A.08.54)	US51350170	Agilent	1 Y	Jan. 28, 2014
Coaxial Cable (C1)	5D-2W(7.0m)	C1	Intertek	1 Y	Jul. 31, 2014
Coaxial Cable (R9)	RG-5A/U(0.2m)	R9	Intertek	1 Y	Jul. 31, 2014
Coaxial Cable (R10)	RG-5A/U(0.4m)	R10	Intertek	1 Y	Jul. 31, 2014
Coaxial Cable (R11)	RG-5A/U(1.1m)	R11	Intertek	1 Y	Jul. 31, 2014
Coaxial Cable (R14)	SUCOFLEX104(1.0m)	229603/4	SUHNER	1 Y	Oct. 31, 2013
Coaxial Cable (R15)	SUCOFLEX104(3.0m)	39677/4	SUHNER	1 Y	Oct. 31, 2013
RF Switch	ACX-150-1	None	Intertek Japan	1 Y	Jul. 31, 2014
Test receiver	ESS (Firmware Version 1.07)	842886/011	Rohde & Schwarz	1 Y	Aug. 31, 2013
38dB rejection test					
Signal Generator	SMB100A	105709	Rohde & Schwarz	1 Y	Jan. 31, 2014
Audio Analyzer	8903B	2818A04372	Hewlett Packard	1 Y	Jul. 31, 2014
Coaxial Cable	SUCOFLEX 104	237767/4	SUHNER	1 Y	May 31, 2014

ANNEX

TEST PROCEDURE(S)

Test was carried out under the following conditions.

Conducted disturbance at mains terminals

Test setup as per standard

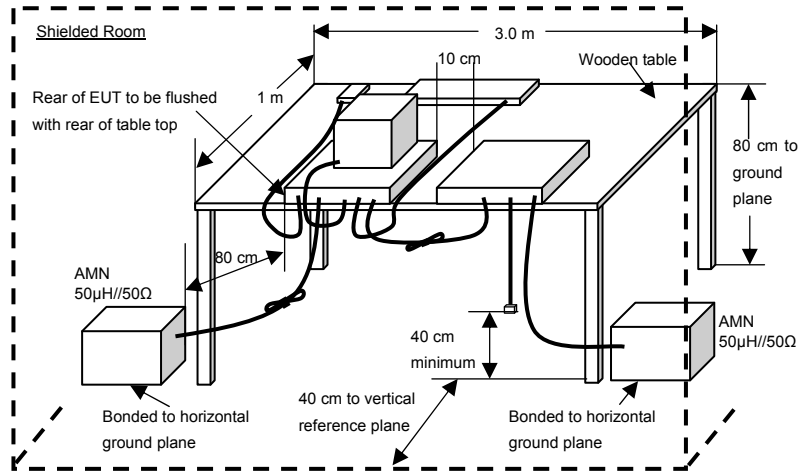

* Reference Ground plane : greater than 2 x 2m

Diagram of the measuring instruments

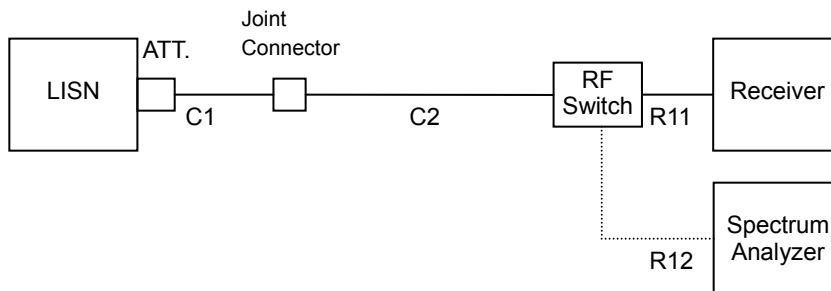

[Preliminary Measurement]

EUT is tested on all operating conditions.

The spectrum analyzer is controlled by the computer program to sweep the frequency range to be measured, then spectrum chart is plotted out to find the worst emission conditions in operating mode and/or configuration decision for the final test.

All leads other than safety ground are tested.

[Final Measurement]

The EUT is operated in the worst emission condition found by the preliminary test.

The equipment and cables are arranged or manipulated within the range of the test standard in the above condition.

At least six highest spectrum are measured in quasi-peak and average (if necessary) using the test receiver.

Radiated disturbance
Test setup as per standard

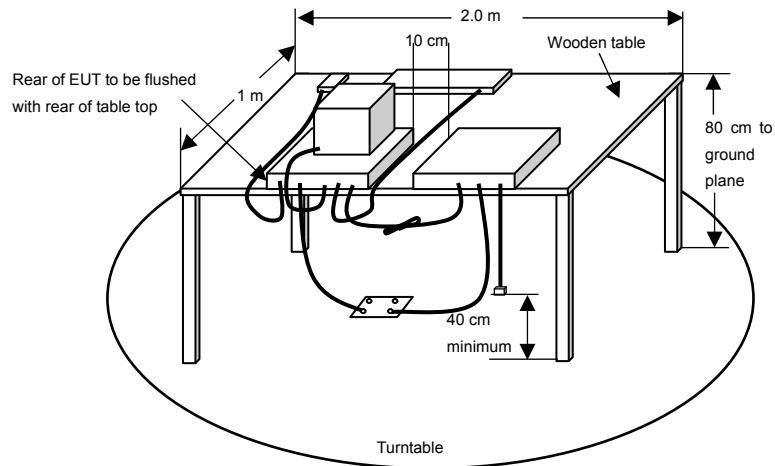
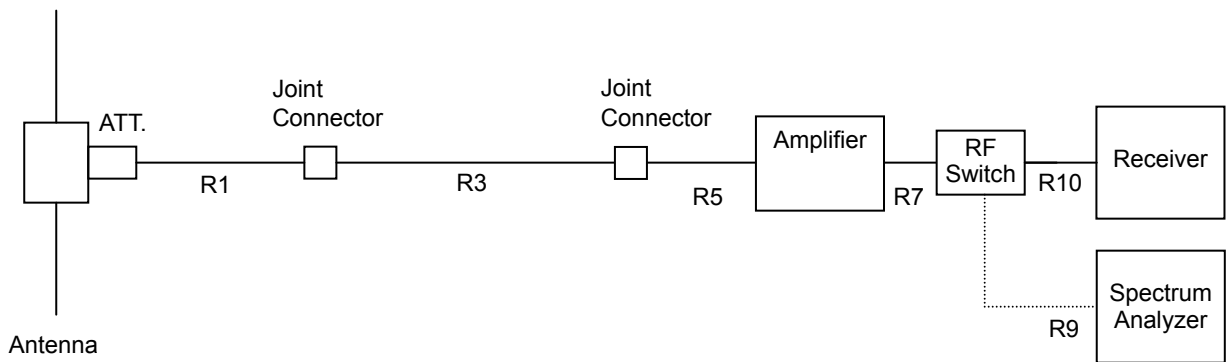
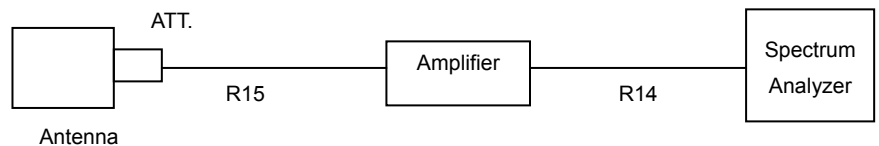

Diagram of the measuring instruments (30-1000MHz)



Above 1GHz



[Preliminary Measurement]

EUT is tested on all operating conditions.

The spectrum analyzer is set max-hold mode and swept during turntable was rotated 0 to 360 degree, And find the worst emission conditions in configuration, operating mode, or ambient noise notation.

[Final Measurement]

The EUT operated in the worst emission condition found by the preliminary test.

The turntable azimuth (EUT direction) and antenna height are adjusted the position so that maximum field strength is obtained for each frequency spectrum to be measured.

The equipment and cables are arranged or manipulated within the range of the test standard in the above condition. At least six highest spectrums are measured by the test receiver (quasi-peak) and spectrum analyzer (peak and average). When the uncertain result was obtained (30 – 1000 MHz), the measurement is retried by using the half wave dipole antenna instead of the broadband antenna.

Conducted Power on Antenna port (15.111)

Schema for the conducted power on antenna port measurement

Diagram of the measuring instruments (30 - 1000MHz)

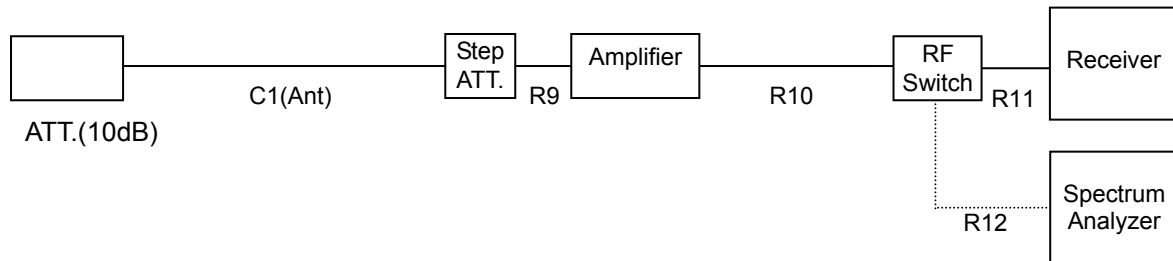

Above 1GHz

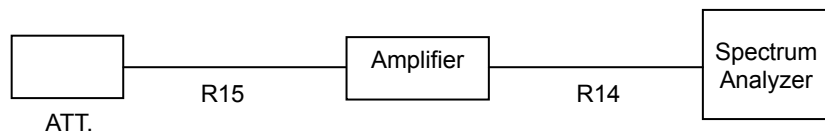

[Preliminary Measurement]

EUT is tested on all operating conditions.

The spectrum analyzer is controlled by the computer program to sweep the frequency range to be measured, then spectrum chart are plotted out to find the worst emission conditions in operating mode and/or configuration decision for the final test.

[Final Measurement]

The EUT is operated in the worst emission condition found by the preliminary test.

The equipment and cables are arranged or manipulated within the range of the test standard in the above condition.

At least six highest spectrum are measured by the test receiver (quasi-peak) and spectrum analyzer (peak).

38dB Rejection test

Schema for the 38dB rejection measurement

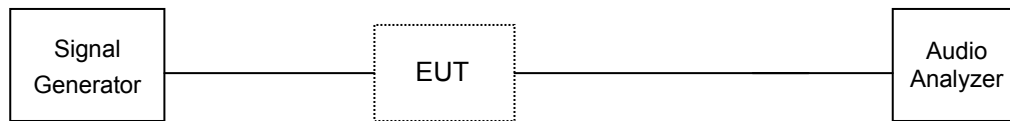

[Preliminary Measurement]

The Signal Generator conditions :

Output level = 66 dBuV.

Modulation = Frequency modulated to 1 kHz tone at 3 kHz peak deviation.

Frequency Points = 824.040 MHz, 836.505 MHz, 848.970 MHz
869.040 MHz, 881.505 MHz, 893.970 MHz

(The Cellular Radiotelephone Service mobile and base frequency bands)

The EUT condition :

Scanning Frequency = 118MHz - 524MHz, 136MHz - 524MHz (5 kHz Step).
800MHz - 1300MHz (10 kHz Step)

Scan stopped point, was the detected frequency.

[Final Measurement]

Injected 12dB SINAD Reading (SG RF Output)

The EUT condition :

Frequency = Scan stopped point

The Signal Generator condition :

Frequency = Cellular point

Detected 12dB SINAD Reading (SG RF Output)

The EUT condition :

Frequency = Scan stopped point

The Signal Generator condition :

Frequency = Scan stopped point

Under the requirements of Section 15.121(b) of the Rule.

Injected 12dB SINAD Reading – Detected 12dB SINAD Reading = 38 dB or more.