



## CERTIFICATE OF COMPLIANCE

**Regulation : FCC Part 2, 22, 74, 90, 90.210  
RSS-119 Issue 6(2000)**

Applicant	Testing Laboratory
Kenwood Corporation 1-16-2, Hakusan, Midori-ku, Yokohama-shi Kanagawa, 226-8525 Japan Tel.: +81 45 939 6254 Fax.: +81 45 939 7093	Akzo Nobel K. K. Kashima No.1 , No.3 , No.10 site FCC Registration Number : 90433 IC File Number : IC-2065-1 , IC-2065-3 1, Oaza Sunayama, Hasaki-machi, Kashima-gun Ibaraki-ken, 314-0255 Japan Tel.: +81 479 40 1097 Fax.: +81 479 46 1788 e-mail: info@akzoemc.co.jp URL: www.akzoemc.co.jp

<b>Equipment type</b>	VHF FM TRANSCEIVER
<b>Trademark</b>	KENWOOD
<b>Model(s)</b>	TK-7160H-K
<b>Serial No.</b>	11
<b>FCC ID</b>	K4437663210
<b>IC CN and UPN</b>	282F-37663210
<b>Measurement Method</b>	ANSI/TIA/EIA-603 / RSS119
<b>Deviation from standard(s)</b>	No deviation
<b>Test Result</b>	Complied
<b>Report Number</b>	ANKK-104215
<b>Report issue date</b>	October 15, 2004

This equipment has been shown to be capable of compliance with the applicable standard(s) as indicated in the test report.

I attest to the accuracy of data. All measurements reported herein were performed by me or were made under my supervision and are correct to the best of my knowledge and belief. I assume full responsibility for the completeness of these measurements and vouch for the qualifications of all persons taking them.

This test report shall not be reproduced partially, or in full, without the prior written approval of Akzo Nobel K. K. The results and statements contained in this report pertain only to the equipment evaluated.

Approved by

\_\_\_\_\_  
Takeshi Yamanaka / [Site Manager]

Tested by

\_\_\_\_\_  
Naoki Ikeda

**TABLE OF CONTENTS**

---

	Page
SECTION 1. GENERAL INFORMATION	3
SECTION 2. TEST AND MEASUREMENT DATA	4
SECTION 3. MEASUREMENT RESULT	5
SECTION 4. TEST DATA	
4.1 Carrier Output Power (Conducted)	6
4.2 Unwanted Emissions (Transmitter Conducted)	7
4.3 Field Strength of Spurious Radiation	9
4.4 Emission Masks (Occupied Bandwidth)	12
4.5 Transient Frequency Behavior	15
4.6 Audio Frequency Response / Audio Low Pass Filter (Voice Input)	18
4.7 Modulation Limiting	20
4.8 Frequency Stability (Temperature Variation)	23
4.9 Frequency Stability (Voltage Variation)	25
4.10 Receiver Spurious Emissions(Radiated)	26
4.11 Necessary Bandwidth and Emission Bandwidth	29
SECTION 5. VALIDITY OF TEST REPORT	30
SECTION 6. DESCRIPTION OF TEST SITE	30
APPENDIX PHOTOGRAPHS	

---



**SECTION 2. TEST AND MEASUREMENT DATA**

All test and measurements indicated in this document were performed in accordance with the Code of Federal Regulations Title 47 Part 2, Sub-part J as the following individual parts:

FCC RULE	TEST ITEM	Tested
Part 21	Domestic Public Fixed radio Services	N.A.
<b>Part 22</b>	<b>Non Cellular</b>	<b>YES</b>
Part 22	Public Mobile Services	N.A.
Part 22	Subpart H - Cellular Radiotelephone Service	N.A.
Part 22	Alternative technologies and auxiliary service	N.A.
Part 23	International Fixed Public Radiocommunication service	N.A.
Part 24	Personal Communications Services	N.A.
<b>Part 74</b>	<b>Subpart H - Low Power Auxiliary Stations</b>	<b>YES</b>
Part 80	Stations in the Maritime Services	N.A.
Part 80	Subpart E - general Technical Standards	N.A.
Part 80	Subpart F - Equipment Authorization for Compulsory Ships	N.A.
Part 80	Subpart K - Private Coast Stations and Marine Utility Stations	N.A.
Part 80	Subpart S - Compulsory radiotelephone Installations for Small Passenger Boats	N.A.
Part 80	Subpart T - Radiotelephone Installation Required for Vessels on the Great Lakes	N.A.
Part 80	Subpart U - Radiotelephone Installations Required by the Bridge-to-Bridge Act	N.A.
Part 80	Subpart V - Emergency Position Indicating Radiobeacons (EPIRB'S)	N.A.
Part 80	Subpart W - Global Maritime Distress and Safety System (GMDSS)	N.A.
Part 80	Subpart X - Voluntary Radio Installations	N.A.
Part 87	Aviation Services	N.A.
<b>Part 90</b>	<b>Private Land Mobile radio Services</b>	<b>YES</b>
Part 94	Private Operational - Fixed Microwave Service	N.A.
Part 95	Subpart A - General Mobile radio Service	N.A.
Part 95	Subpart C - Radio Control (R/C) radio Service	N.A.
Part 95	Subpart D - Citizens Band (CB) Radio Service	N.A.
Part 95	Subpart E -Family radio Service	N.A.
Part 95	Subpart F -Interactive Video and Data Service (IVDS)	N.A.
Part 97	Amateur Radio Service	N.A.
Part 101	Fixed Microwave Service	N.A.

IC RULE	TEST ITEM	Tested
<b>RSS-119</b>	<b>Land Mobile and Fixed Radio Transmitters and Receivers</b>	<b>YES</b>

**SECTION 3. MEASUREMENT RESULT**

FCC RULE	IC RULE	TEST ITEM	RESULTS
2.1046 (a)	6.2	Carrier Output Power (Conducted)	PASS
2.1051, 90.210	6.3	Unwanted Emissions (Transmitter Conducted)	PASS
2.1053 (a), 90.210	6.3	Field Strength of Spurious Radiation	PASS
2.1049 (c) (1), 90.210	6.4	Emission Masks (Occupied Bandwidth)	PASS
90.214	6.5	Transient Frequency Behavior	PASS
2.1047 (a), 90.242(b)(8)	6.6	Audio Low Pass Filter (Voice Input)	PASS
2.1047 (a)	-	Audio Frequency Response	PASS
2.1047 (b)	6.6	Modulation Limiting	PASS
2.1055 (a) (1), 90.213(a)	7	Frequency Stability (Temperature Variation)	PASS
2.1055 (d) (1), 90.213(a)	7	Frequency Stability (Voltage Variation)	PASS
-	8	Receiver Spurious Emissions	PASS
2.202 (g)	-	Necessary Bandwidth and Emission Bandwidth	PASS

**Limitation on Results**

The test result of this report is effective equipment under test itself and under the test configuration described on the report.

This test report does not assure that whether the test result taken in other testing laboratory is compatible or reproducible to the test result on this report or not.

**SECTION 4. TEST DATA**

**4.1 Carrier Output Power (Conducted)**

REGULATIONS	: 47 CFR 2.1046 (a) / RSS-119 Section 6.2
TEST METHOD/GUIDE	: ANSI/TIA/EIA-603-1992, section 2.2.1.2 / RSS-119 Section 6.2

**TEST PROCEDURE**

- 1 The EUT and test equipment were set up as shown on the following page.
- 2 The EUT was conducted to a resistive coaxial attenuator of normal load impedance.

RF Power (dBm) = Power Meter reading (dBm) + Attenuator (dB) + Cable loss (dB)

RF Power (W) = 10^(RF Power (dBm)/10)/1000

**TEST EQUIPMENTS**

No.	Equipment	Manufacture	Model No.	Serial No.	Cal Exp.
1	Power Meter	Hewlett Packard	E4418B	GB38410265	Sep-05
2	Power Sensor	Hewlett Packard	8482A	2607A11551	Sep-05
3	Attenuator (20dB)	Weinschel	40-20-34	AA5701	Jul-05
4	Attenuator (20dB)	Radiall	R414720161	03-24	Jul-05
5	Attenuator (10dB)	TME	CFA-05NPJ-10	262843	Jun-05
6	DC Power Supply	KIKUSUI	PAD35-30L	None	None

**MEASUREMENT EQUIPMENT CONFIGURATION**

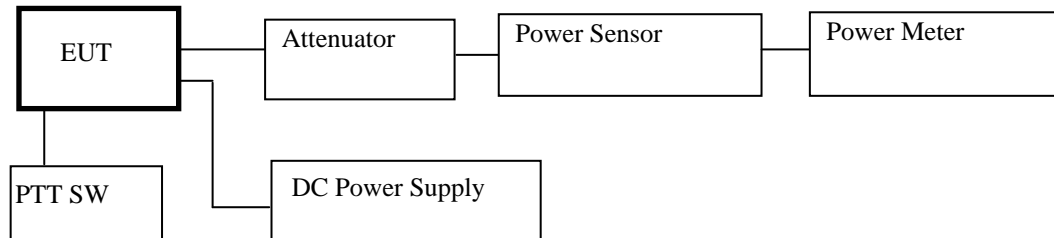

**UNCERTAINTY**

Measurement uncertainty is +/- 0.5dB (k = 2)

**TEST RESULTS**

Measured for the worst case

No.	Frequency (MHz)	Setting	RF Power (W)
1	136.10	Low High Power	50
2	155.10	Mid High Power	50
3	173.90	High High Power	50
4	136.10	Low Low Power	25
5	155.10	Mid Low Power	25
6	173.90	High Low Power	25

**4.2 Unwanted Emissions (Transmitter Conducted)**

REGULATIONS	: 47 CFR 2.1051, 90.210 / RSS-119 Section 6.3
TEST METHOD/GUIDE	: ANSI/TIA/EIA-603-1992, section 2.2.13.2 / RSS-119 Section 6.3

**TEST PROCEDURE**

- 1 The EUT and test equipment were set up as shown on the following page.
- 2 Modulate the transmitter with a 2.5 kHz sine wave at an input Level of 16 dB greater than that necessary to produce 50 % of rated system deviation.
- 3 Adjust the spectrum analyzer for the following setting:
  - a) Resolution Bandwidth : 10 kHz (< 1 GHz), 1 MHz (> 1 GHz).
  - b) Video Bandwidth : 30 kHz (< 1 GHz), 3 MHz (> 1 GHz).
  - c) Sweep Speed : 50 msec.
  - d) Detector mode : Average
- 4 The emissions were measured for the worst case as follows:
  - a) : within a band of frequencies defined by the carrier frequency plus and minus one channel.
  - b) : from the lowest frequency generated in the EUT and to at least the 10th harmonic of the carrier frequency, or 40 GHz, whichever is lower.

**TEST EQUIPMENTS**

No.	Equipment	Manufacture	Model No.	Serial No.	Cal Exp.
1	Audio Generator	ANRITSU	MG443B	1004468	Jul-05
2	Attenuator (20dB)	Weinschel	40-20-34	AA5701	Jul-05
3	Attenuator (20dB)	Radiall	R414720161	03-24	Jul-05
4	Attenuator (10dB)	TME	CFA-05NPJ-10	262843	Jun-05
5	High Pass Filter	ANRITSU	MP526B	6200220636	Jun-05
6	Modulation Analyzer	Hewlett Packard	8901B	4TG-3008	Sep-05
7	Signal Generator	Rohde & Schwarz	SMG	860289/011	May-05
8	Signal Generator	Rohde & Schwarz	SMR40	834128/028	Sep-05
9	Spectrum Analyzer	Agilent	E7403A	MY42000062	Jul-05
10	DC Power Supply	KIKUSUI	PAD35-30L	None	None

**MEASUREMENT EQUIPMENT CONFIGURATION**

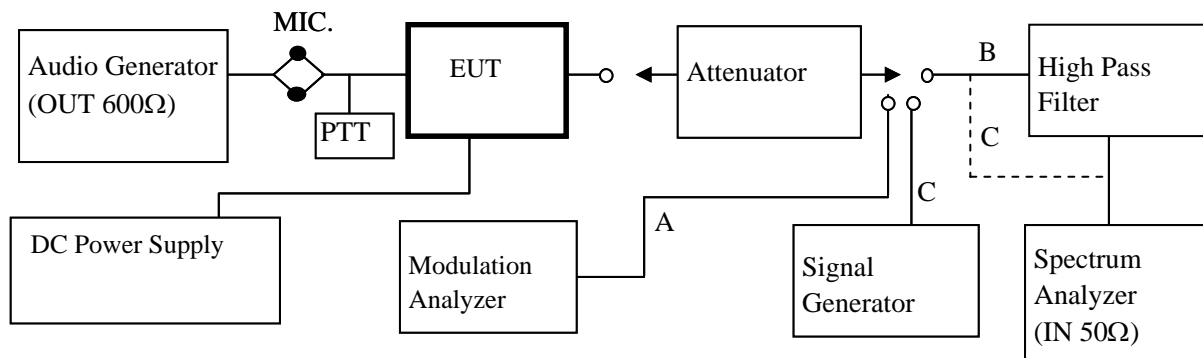

**UNCERTAINTY**

Measurement uncertainty is +/- 1.2 dB (k = 2)

**TEST RESULTS**

Measured for the worst case

State : High Power / Narrow Band Modulation

No.	Frequency (MHz)		Correct Level (dBm)	Emission Level (dBc)	Limit (dBc)	Margin (dB)
1	272.20	Low	-36.02	-83.01	-67.0	16.0
2	465.30	Mid	-40.52	-87.51	-67.0	20.5
3	521.70	High	-43.37	-90.36	-67.0	23.4

There is the margin of 20dB over except for the above points.

State : Low Power / Narrow Band Modulation

No.	Frequency (MHz)		Correct Level (dBm)	Emission Level (dBc)	Limit (dBc)	Margin (dB)
1	272.20	Low	-32.62	-76.60	-64.0	12.6
2	310.20	Mid	-42.29	-86.27	-64.0	22.3
3	347.80	High	-45.34	-89.31	-64.0	25.3

There is the margin of 20dB over except for the above points.

Mask D Limit (dBc) =  $-(50+10\log(P))$

Correct Level (dBm) = Substitute SG Level (dBm) + Attenuator loss (dB) (+ High Pass Filter loss (dB))

Emission Level (dBc) = Correct Level (dBm) -  $10\log(P*1000)$

P = Carrier Level (W)



**4.3 Field Strength of Spurious Radiation**

REGULATIONS	: 47 CFR 2.1053 (a), 90.210 / RSS-119 Section 6.2
TEST METHOD/GUIDE	: ANSI/TIA/EIA-603-1992, section 2.2.12.2 / RSS-119 Section 6.2

**TEST PROCEDURE**

- 1 The EUT and test equipment were set up as shown on the following page.
- 2 Adjust the spectrum analyzer for the following setting:
  - a) Resolution Bandwidth : 10 kHz (< 1 GHz), 1 MHz (> 1 GHz).
  - b) Video Bandwidth : 300 kHz (< 1 GHz), 3 MHz (> 1 GHz).
  - c) Sweep Speed : 50ms.
  - d) Detector mode : Positive Peak
- 3 The transmitter was placed on a wooden turntable, and it was transmitting into non-radiating load which was also placed on the turntable.
- 4 The measurement antenna was placed at a distance of 3 meters from the EUT. During the tests, the antenna height and polarization as well as EUT azimuth were varied in order to identify the maximum level of emissions from the EUT. The test was performed by placing the EUT on 3-orthogonal axis.
- 5 The frequency range up to tenth harmonic of the fundamental frequency was investigated.
- 6 Remove the EUT and replace it with substitution antenna. A signal generator was connected to the substitution antenna by a non-radiating cable. The absolute levels of the spurious emissions were measured by the substitution.
- 7 Spurious emissions in dB = 10 Log (TX power in Watts/0.001) – the absolute level
- 8 Spurious attenuation Wide Band Modulaion limit in dB = 43 + 10 Log10 (power out in Watts)
- 9 Spurious attenuation Narrow Band Modulaion limit in dB = 50 + 10 Log10 (power out in Watts)

**TEST EQUIPMENTS**

No.	Equipment	Manufacture	Model No.	Serial No.	Cal Exp.
1	Dipole Antenna(TX)	Schwarzbeck	VHA9103	None	Jan-05
2	Dipole Antenna(TX)	Schwarzbeck	UHA9105	None	Jun-05
3	D.R.G Antenna(TX)	Schwarzbeck	3115	9612-5046	Jun-05
4	Tri-log Antenna(RX)	Schwarzbeck	VULB9167WP	106	Feb-05
5	D.R.G Antenna(RX)	Schwarzbeck	3115	9612-5044	Jul-05
6	Step Attenuater	HP	8464B	2726A14513	Oct-04
7	Pre-Amplifier	HP	83051A	3332A00329	Aug-05
8	Attenuator(6dB)	ANRITSU	MP720B	M57593	Oct-04
9	Attenuator(3dB)	Narda	3157845	4538	Aug-05
10	Spectrum Analyzer	HP	8563E	3642A00665	Jul-05
11	Signal Generator	Rohde & Schwars	SMG	860289/011	Jun-05
12	Signal Generator	Rohde & Schwars	SMR40	834128/028	Sep-05
13	Dummy Load	BIRD	8401	6163	Jun-05
14	DC Power Supply	Metronix	MSV18A-14	None	None

**MEASUREMENT EQUIPMENT CONFIGURATION**

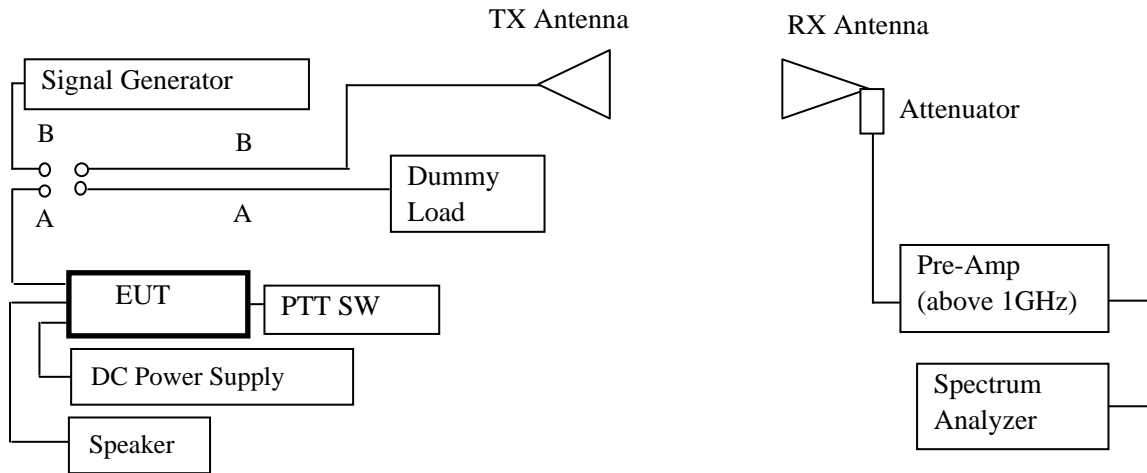

**UNCERTAINTY**

Measurement uncertainty is +/- 4.2dB (k = 2)

**TEST RESULTS**

Measured for the worst case

State : High Power / Narrow Band Modulation / 173.90 MHz

No	Frequency (MHz)	Pol	Reading Level (dBm)	SG Out Level (dBm)	Cable Loss (dB)	Antenna Gain (dBi)	Correct Level (dBm)	Emission Level (dBc)	Limit Level (dBc)	Margin (dB)
1	347.80	Hor.	-63.25	-31.30	0.87	2.15	-30.0	-77.0	-67.0	10.0
		Ver.	-61.58	-26.80	0.87	2.15	-25.5	-72.5	-67.0	5.5
2	521.70	Hor.	-72.75	-34.00	1.06	2.15	-32.9	-79.9	-67.0	12.9
		Ver.	-75.67	-35.30	1.06	2.15	-34.2	-81.2	-67.0	14.2
3	695.60	Hor.	-90.20	-52.40	1.23	2.15	-51.5	-98.5	-67.0	31.5
		Ver.	-78.50	-39.30	1.23	2.15	-38.4	-85.4	-67.0	18.4
4	1043.40	Hor.	-59.67	-58.50	1.51	6.22	-53.8	-100.8	-67.0	33.8
		Ver.	-53.17	-51.30	1.51	6.22	-46.6	-93.6	-67.0	26.6
5	1217.30	Hor.	-60.50	-60.70	1.63	7.31	-55.0	-102.0	-67.0	35.0
		Ver.	-55.00	-53.20	1.63	7.31	-47.5	-94.5	-67.0	27.5
6	1391.20	Hor.	-55.50	-54.90	2.85	8.23	-49.5	-96.5	-67.0	29.5
		Ver.	-52.33	-50.70	2.85	8.23	-45.3	-92.3	-67.0	25.3
7	1565.10	Hor.	-59.83	-63.00	3.03	8.80	-57.2	-104.2	-67.0	37.2
		Ver.	-55.33	-55.60	3.03	8.80	-49.8	-96.8	-67.0	29.8
8	1739.00	Hor.	-57.83	-56.10	3.22	8.92	-50.4	-97.4	-67.0	30.4
		Ver.	-52.50	-50.50	3.22	8.92	-44.8	-91.8	-67.0	24.8

There is the margin of 20dB over except for the above points.

Mask D Limit (dBc) =  $-(50+10\text{Log}(P))$

Correct Level (dBm) = Substitute SG Level (dBm) + ANT Gain (dBi) - Cable loss (dB)

Emission Level (dBc) = Correct Level (dBm) -  $10\text{Log}(P*1000)$

P = Carrier Level (W)

State : Low Power / Narrow Band Modulation / 173.90 MHz

No	Frequency (MHz)	Pol	Reading Level (dBm)	SG Out Level (dBm)	Factor* (dB)	Antenna Gain (dBi)	Correct Level (dBm)	Emission Level (dBc)	Limit Level (dBc)	Margin (dB)
1	347.80	Hor.	-61.83	-30.10	0.87	2.15	-28.8	-72.8	-64.0	8.8
		Ver.	-62.08	-26.80	0.87	2.15	-25.5	-69.5	-64.0	5.5
2	521.70	Hor.	-74.00	-35.20	1.06	2.15	-34.1	-78.1	-64.0	14.1
		Ver.	-76.33	-36.40	1.06	2.15	-35.3	-79.3	-64.0	15.3
3	695.60	Hor.	-87.67	-49.80	1.23	2.15	-48.9	-92.9	-64.0	28.9
		Ver.	-77.83	-38.50	1.23	2.15	-37.6	-81.6	-64.0	17.6
4	1043.40	Hor.	-63.30	-64.70	1.51	6.22	-60.0	-104.0	-64.0	40.0
		Ver.	-57.00	-56.60	1.51	6.22	-51.9	-95.9	-64.0	31.9
5	1217.30	Hor.	-65.50	-71.70	1.63	7.31	-66.0	-110.0	-64.0	46.0
		Ver.	-62.25	-65.00	1.63	7.31	-59.3	-103.3	-64.0	39.3
6	1391.20	Hor.	-63.92	-69.50	2.85	8.23	-64.1	-108.1	-64.0	44.1
		Ver.	-57.43	-56.70	2.85	8.23	-51.3	-95.3	-64.0	31.3
7	1565.10	Hor.	-63.83	-69.40	3.03	8.80	-63.6	-107.6	-64.0	43.6
		Ver.	-64.00	-69.80	3.03	8.80	-64.0	-108.0	-64.0	44.0
8	1739.00	Hor.	-63.67	-67.50	3.22	8.92	-61.8	-105.8	-64.0	41.8
		Ver.	-60.58	-60.70	3.22	8.92	-55.0	-99.0	-64.0	35.0

There is the margin of 20dB over except for the above points.

Mask D Limit (dBc) = -(50+10Log(P))

Correct Level (dBm) = Substitute SG Level (dBm) + ANT Gain (dBi) - Cable loss (dB)

Emission Level (dBc) = Correct Level (dBm) - 10Log(P\*1000)

P = Carrier Level (W)

**4.4 Emission Masks (Occupied Bandwidth)**

REGULATIONS	: 47 CFR 2.1049 (c) (1), 90.210 / RSS-119 Section 6.4
TEST METHOD/GUIDE	: ANSI/TIA/EIA-603-1992, section 2.2.11.2 / RSS-119 Section 6.4

**TEST PROCEDURE**

- 1 The EUT and test equipment were set up as shown on the following page.
- 2 For EUT supporting audio modulation, the audio signal generator was adjusted to the frequency of maximum response and with output level set for +/- 2.5 kHz or +/- 1.25 kHz deviation (or 50 % modulation).
- 3 With level constant, the signal level was increased 16 dB.  
For EUT supporting digital modulation, the digital modulation mode was operated to its maximum extent.
- 4 Adjust the spectrum analyzer for the following setting:
  - a) Resolution Bandwidth : 100 Hz (Nonmodulation and Narrow modulation), 300 Hz (Wide modulation).
  - b) Video Bandwidth : 100 Hz (Nonmodulation and Narrow band modulation), 3kHz(Wide band modulation).
  - c) Sweep Speed : 8 sec.
  - d) Sampling Time : 10 times
- 5 The occupied Bandwidth was measured with the Spectrum Analyzer controls set as shown on the test results.

**TEST EQUIPMENTS**

No.	Equipment	Manufacture	Model No.	Serial No.	Cal Exp.
1	Audio Generator	ANRITSU	MG443B	1004468	Jul-05
2	Attenuator (20dB)	Weinschel	40-20-34	AA5701	Jul-05
3	Attenuator (20dB)	Radiall	R414720161	03-24	Jul-05
4	Attenuator (10dB)	TME	CFA-05NPJ-10	262843	Jun-05
5	Modulation Analyzer	HP	8901B	4TG-3008	Sep-05
6	Spectrum Analyzer	Agilent	E7403A	MY42000062	July-05
7	DC Power Supply	KIKUSUI	PAD35-30L	None	None

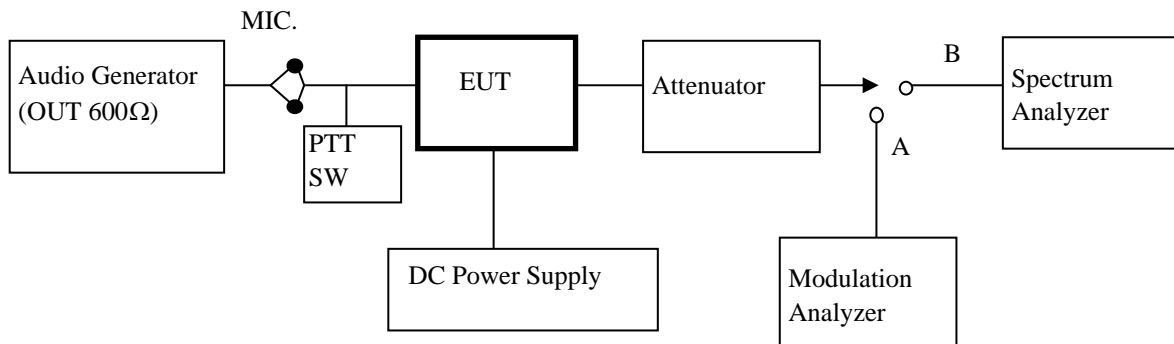

**UNCERTAINTY**

Measurement uncertainty is +/- 1.2dB (k = 2)

### TEST RESULTS

Measured for the worst case

State : High Power / None Modulation:FM / 155.10 MHz

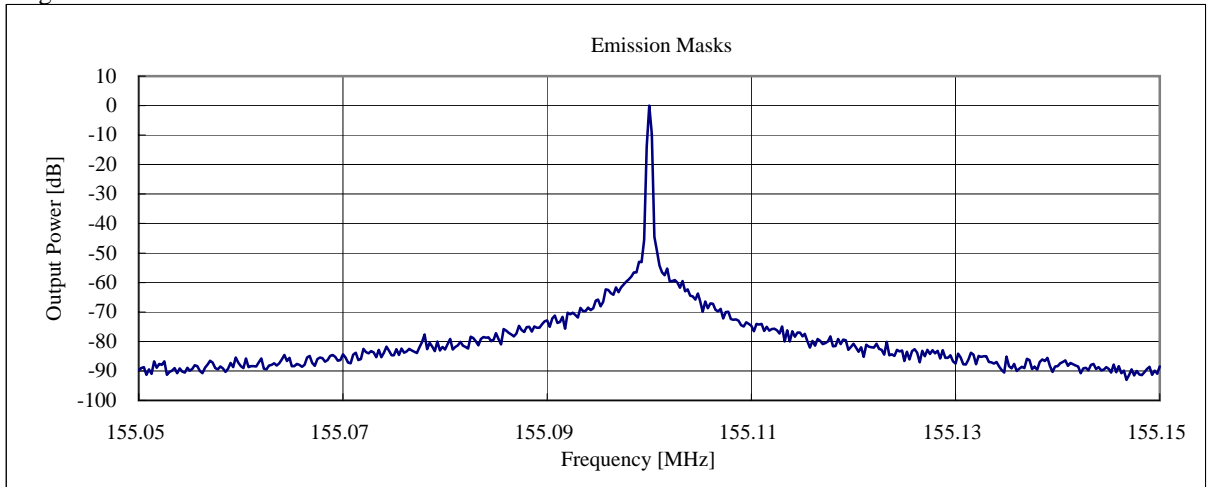

State : High Power / Narrow Modulation:FM / 155.10 MHz

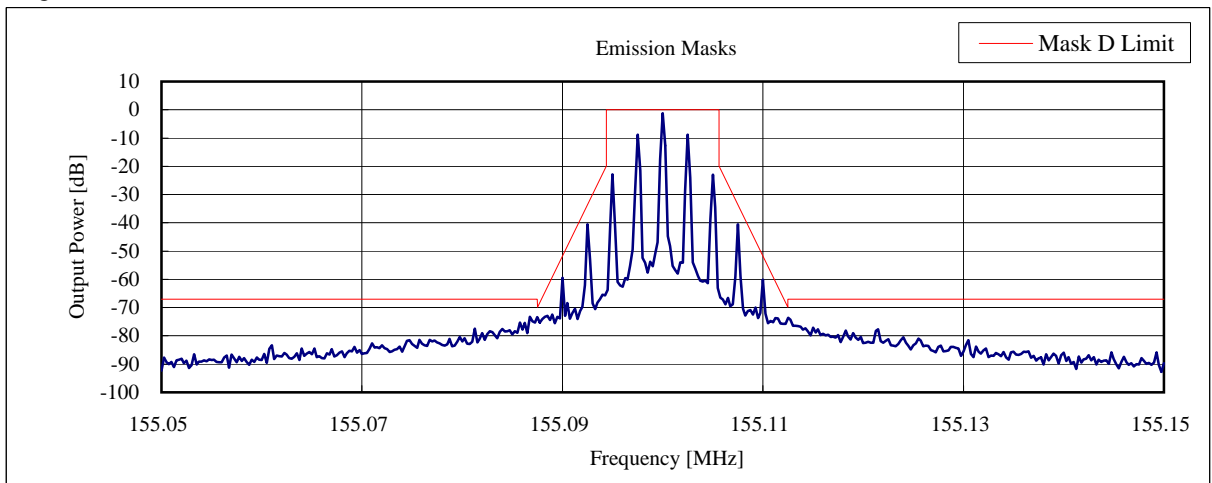

State : High Power / Wide Modulation:FM / 155.10 MHz

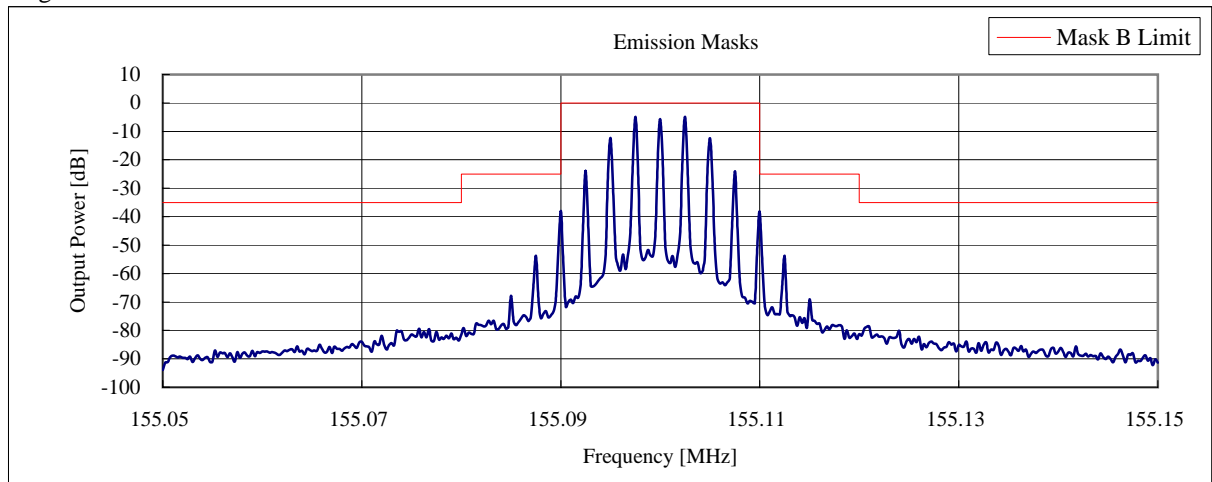

State : Low Power / None Modulation:FM / 155.10 MHz

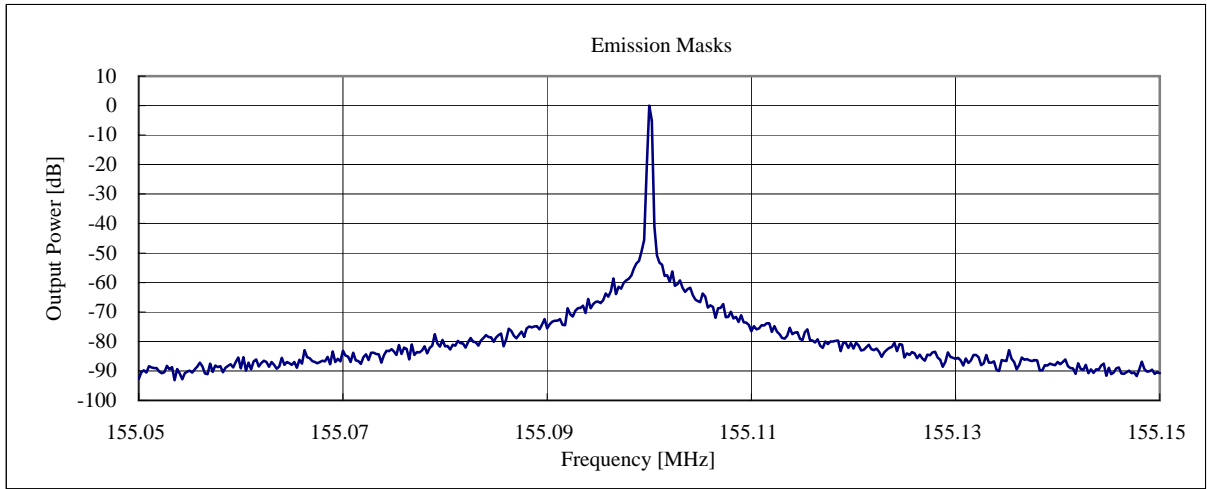

State : Low Power / Narrow Modulation:FM / 155.10 MHz

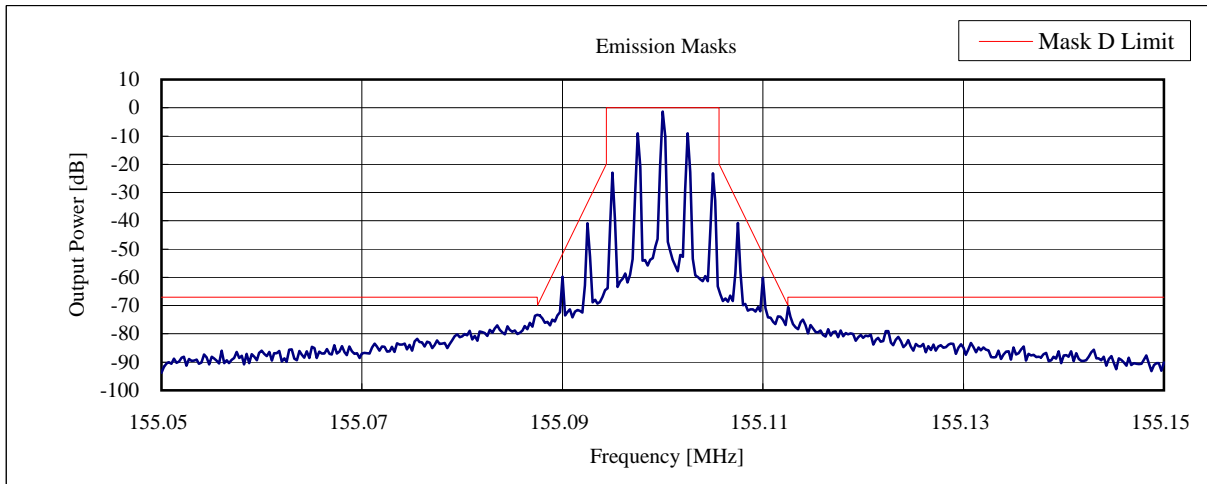

State : Low Power / Wide Modulation:FM / 155.10 MHz

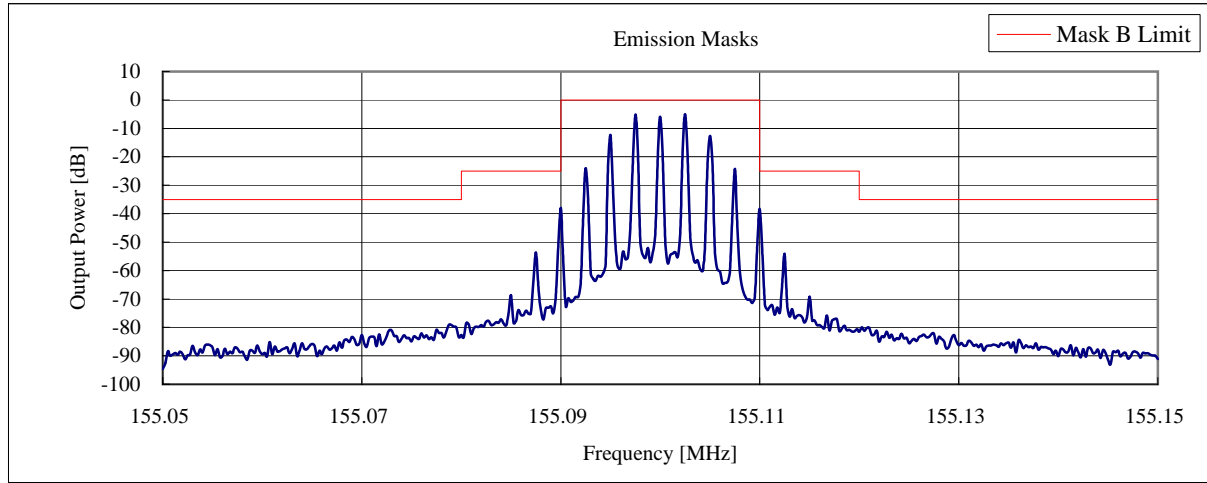

**4.5 Transient Frequency Behavior**

REGULATIONS	: 47 CFR 90.214 / RSS-119 Section 6.5
TEST METHOD/GUIDE	: ANSI/TIA/EIA-603-1992, section 2.2.19.3 / RSS-119 Section 6.5

**TEST PROCEDURE**

- 1 The EUT and test equipment were set up as shown on the following page.
- 2 The transmitter was turned on.
- 3 Sufficient attenuation was provided so that the transmitter carrier level measured at the output of the combiner was 40 dB below the maximum input level of the test receiver.  
This level was recorded as step f.
- 4 The transmitter was turned off.
- 5 An RF signal generator (1) modulated with a 1 kHz tone at either 25 kHz or 12.5 kHz deviation, and set to the same frequency as the assigned transmitter frequency, (2) was adjusted to a level -20 dB below the level recorded for step f, as measured at the output of the combiner.  
This level was then fixed for the remainder of the test and is recorded at step h.
- 6 The oscilloscope was setup using TIA/EIA-603 steps j and k as a guide, and to 10 msec./div.
- 7 The transmitter was turned on, and the level of the carrier at the output of the combiner was recorded as step l.
- 8 The carrier on-time as referenced in TIA/EIA-603 steps m, n, and o was captured and plotted.
- 9 The carrier off-time as referenced in TIA/EIA-603 steps p, q, r, and s was captured and plotted.

**TEST EQUIPMENTS**

No.	Equipment	Manufacture	Model No.	Serial No.	Cal Exp.
1	Signal Generator	Rohde & Schwarz	SMG	860289/011	Jun-05
2	Oscilloscope	IWATSU-LeCroy	LT342	00922	Aug-05
3	Power Meter	HP	E4418B	GB38410265	Sep-05
4	Power Sensor	HP	8482A	2607A11551	Sep-05
5	Attenuator (20dB)	Weinschel	40-20-34	AA5701	Jul-05
6	Attenuator (3dB)	TMA	CFA-20NPJ-3	679701	Aug-05
7	Modulation Analyzer	Hewlett Packard	8901B	4TG-3008	Sep-05
8	Combiner	ANRITSU	Z-164A	M89249	Jul-05
9	Combiner	ANRITSU	Z-164A	M89549	Jul-05
10	DC Power Supply	KIKUSUI	PAD35-30L	None	None

**MEASUREMENT EQUIPMENT CONFIGURATION**

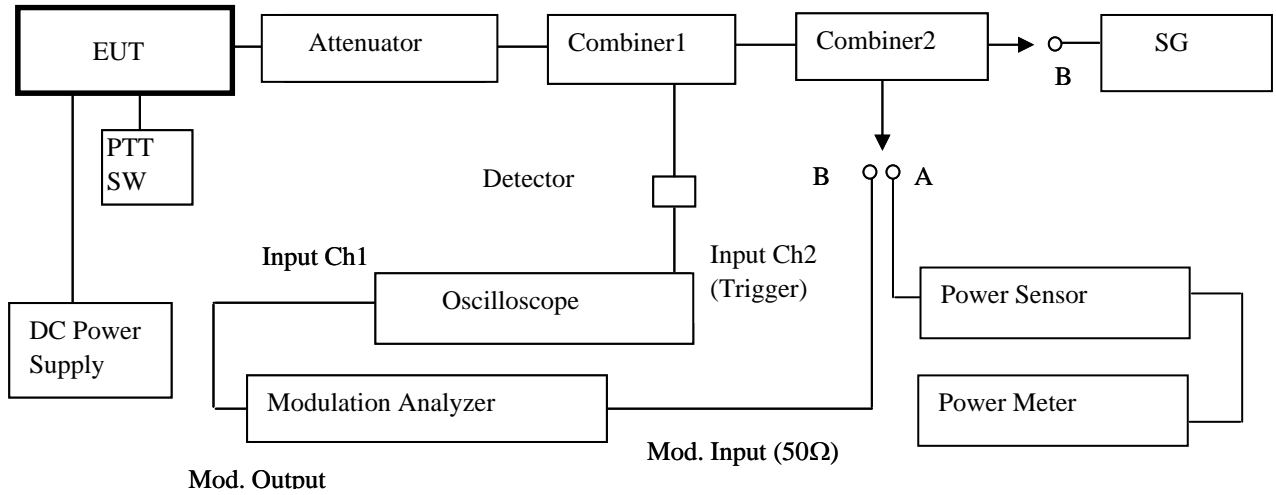

**UNCERTAINTY**

Measurement uncertainty is +/- 1.3dB (k = 2)

**TEST RESULTS**

Measured for the worst case

PTT: OFF-ON

State : High Power / Wide Band Modulation / 173.90 MHz

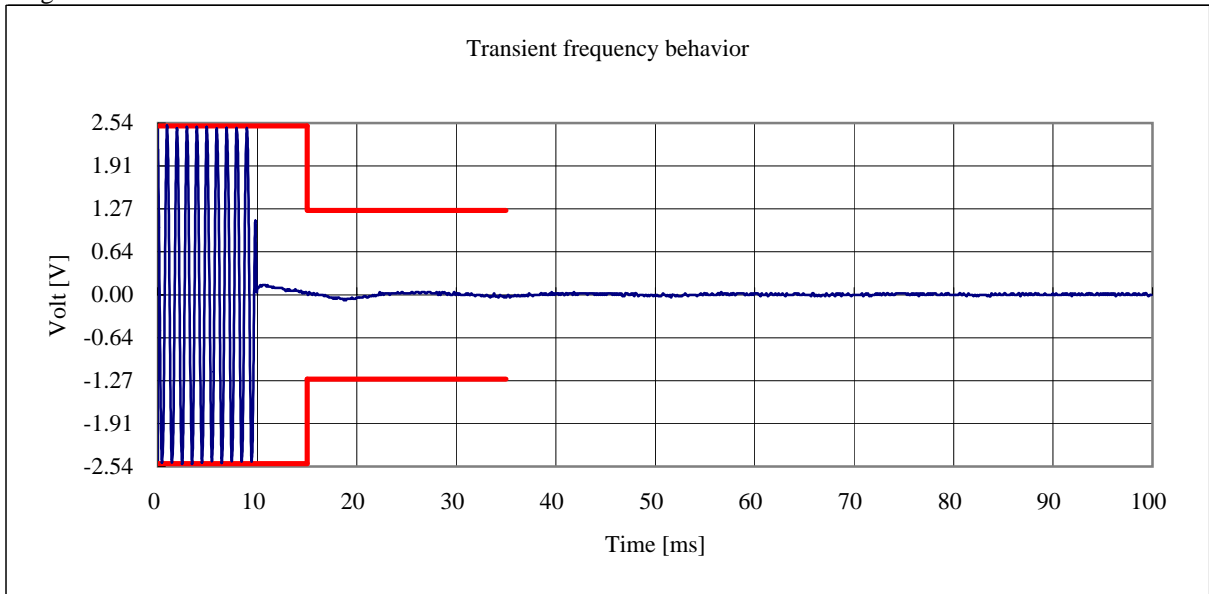



PTT: ON-OFF

State : High Power / Wide Band Modulation / 173.90 MHz

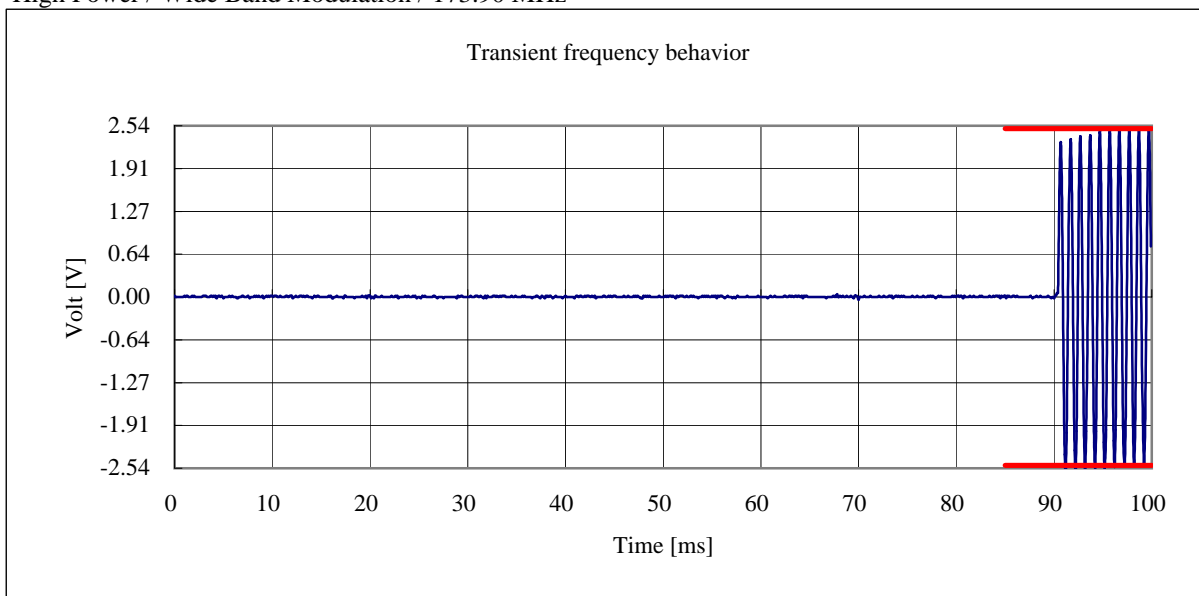

**4.6 Audio Frequency Response / Audio Low Pass Filter (Voice Input)**

REGULATIONS	: 47 CFR 2.1047 (a) / RSS-119 Section 6.6
TEST METHOD/GUIDE	: ANSI/TIA/EIA-603-1992, section 2.2.6.2.2, 3.2.6.2 / RSS-119 Section 6.6

**TEST PROCEDURE**

- 1 The EUT and test equipment were set up as shown on the following page.
- 2 Adjust the Modulation Analyzer for the following setting:
  - a) High-pass filter : 50 Hz
  - b) Low-pass filter : 15 kHz
  - c) Detector : positive peak
  - d) Function : FM
- 3 The audio signal input was adjusted to obtain 20 % modulation at 1 kHz, and this point was taken as the 0 dB reference level.
- 4 With input levels held constant and below limiting at all frequencies, the audio signal generator was varied from 300 Hz to 5 kHz.
- 5 The response in dB relative to 1 kHz was then measured, using the Modulation Analyzer.

**TEST EQUIPMENTS**

No.	Equipment	Manufacture	Model No.	Serial No.	Cal Exp.
1	Audio Generator	ANRITSU	MG443B	1004468	Jul-05
2	Attenuator (20dB)	Weinschel	40-20-34	AA5701	Jul-05
3	Attenuator (20dB)	Radiall	R414720161	03-24	Jul-05
4	Attenuator (10dB)	TME	CFA-05NPJ-10	262843	Jun-05
5	Modulation Analyzer	HP	8901B	4TG-3008	Sep-05
6	Digital Multi Meter	HP	34401A	US36043517	Jul-05
7	DC Power Supply	KIKUSUI	PAD35-30L	None	None

**MEASUREMENT EQUIPMENT CONFIGURATION**

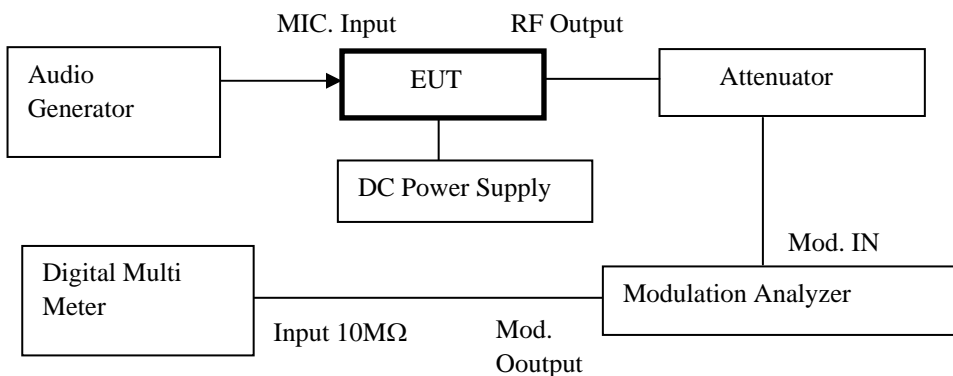

**UNCERTAINTY**

Measurement uncertainty is +/- 1.2dB (k = 2)

**TEST RESULTS**

Measured for the worst case

State : High Power / Wide Band Modulation / 155.10 MHz

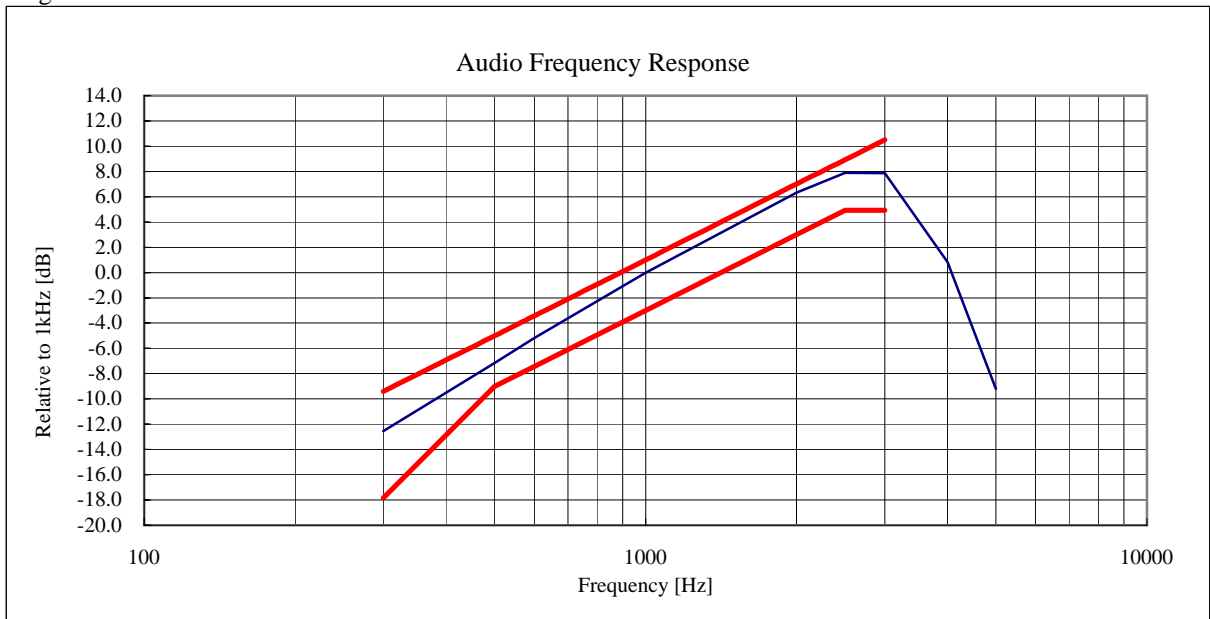

State : High Power / Narrow Band Modulation / 155.10 MHz

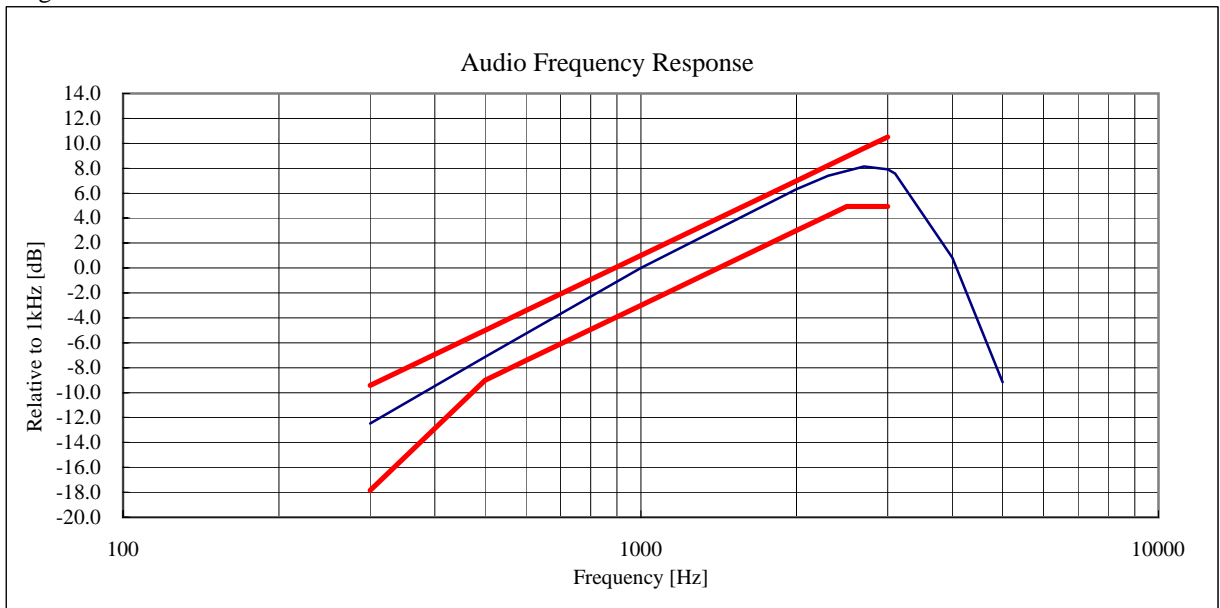

Note:

Audio Filter of the above result is substituted with the same structure as Audio Frequency Resonse.  
 On the transmission condition below 3kHz, Transceiver shows pre-emphasis condition of transmission function.  
 On the transmission condition above 3kHz, Transceiver shows Audio Low Pass Filter.

**4.7 Modulation Limiting**

REGULATIONS	: 47 CFR 2.1047 (b) / RSS-119 Section 6.6
TEST METHOD/GUIDE	: ANSI/TIA/EIA-603-1992, section 2.2.3.2, 1.3.4.4 / RSS-119 Section 6.6

**TEST PROCEDURE**

- 1 The EUT and test equipment were set up as shown on the following page.
- 2 Adjust the Modulation Analyzer for the following setting:
  - a) High-pass filter : off
  - b) Low-pass filter : 15 kHz
  - c) Detector : positive peak
  - d) Function : FM
- 3 Apply a 1kHz modulating signal to the transmitter from the audio generator, and adjust the level to obtain 60% of full rated system deviation.
- 4 Measure the modulation frequency that was showed on the Modulation Analyzer when the output levels of the Audio Generator were changed from -20 dB to +50 dB by 10 dB.
- 5 Set the output frequencies of the Audio Generator 300 Hz and 3 kHz, and repeat test procedure 4.
- 6 Set the the Detector of the Modulation Analyzer Negative Peak.
- 7 Repeat test procedure 4 and 5.

**TEST EQUIPMENTS**

No.	Equipment	Manufacture	Model No.	Serial No.	Cal Exp.
1	Audio Generator	ANRITSU	MG443B	1004468	Jul-05
2	Attenuator (20dB)	Weinschel	40-20-34	AA5701	Jul-05
3	Attenuator (20dB)	Radiall	R414720161	03-24	Jul-05
4	Attenuator (10dB)	TME	CFA-05NPJ-10	262843	Jun-05
5	Modulation Analyzer	HP	8901B	4TG-3008	Sep-05
6	DC Power Supply	KIKUSUI	PAD35-30L	None	None

**MEASUREMENT EQUIPMENT CONFIGURATION**

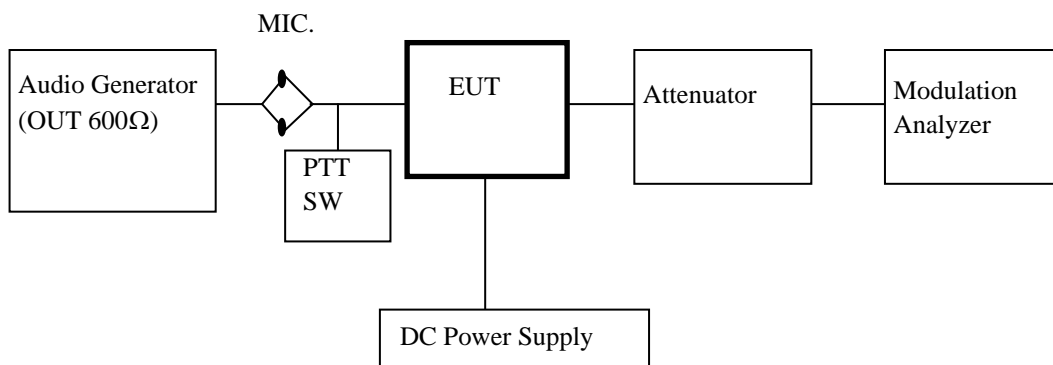

**UNCERTAINTY**

Measurement uncertainty is +/- 0.8dB (k = 2)

### TEST RESULTS

Measured for the worst case

State : High Power / Wide Modulation / 136.10 MHz

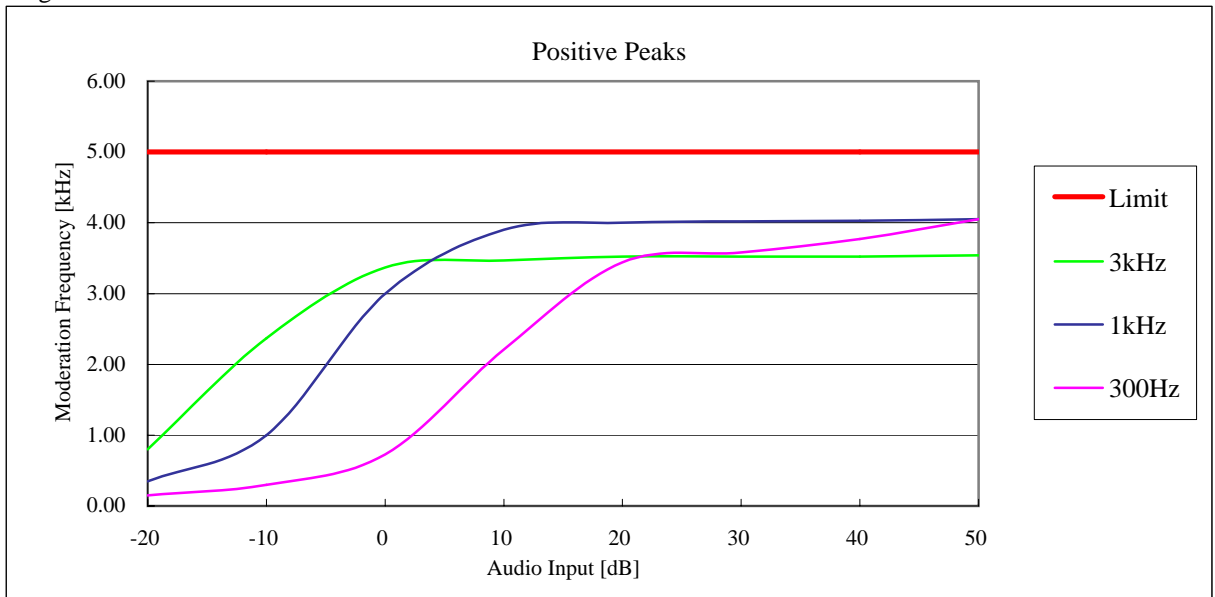

State : High Power / Wide Modulation / 136.10 MHz

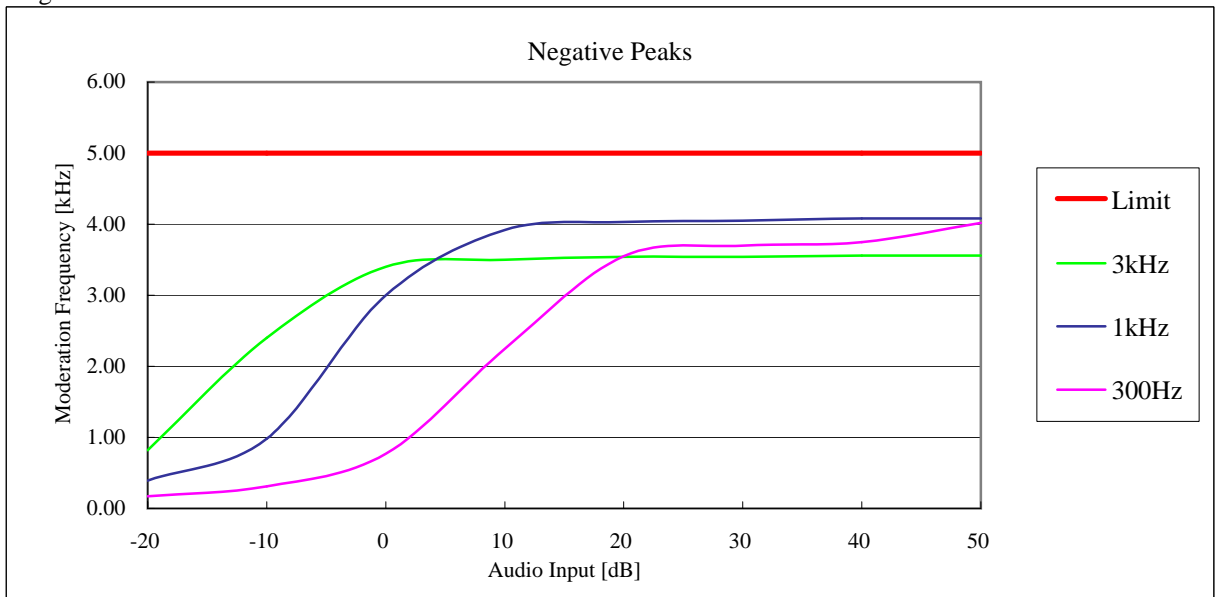

State : High Power / Narrow Modulation / 136.10 MHz

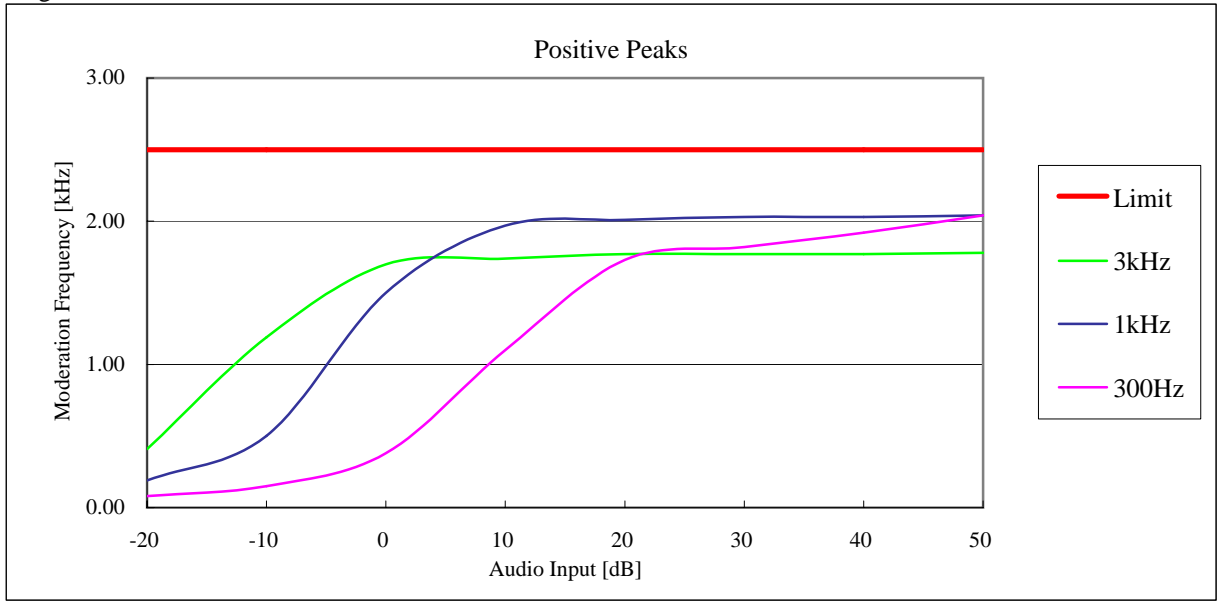

State : High Power / Narrow Modulation / 136.10 MHz

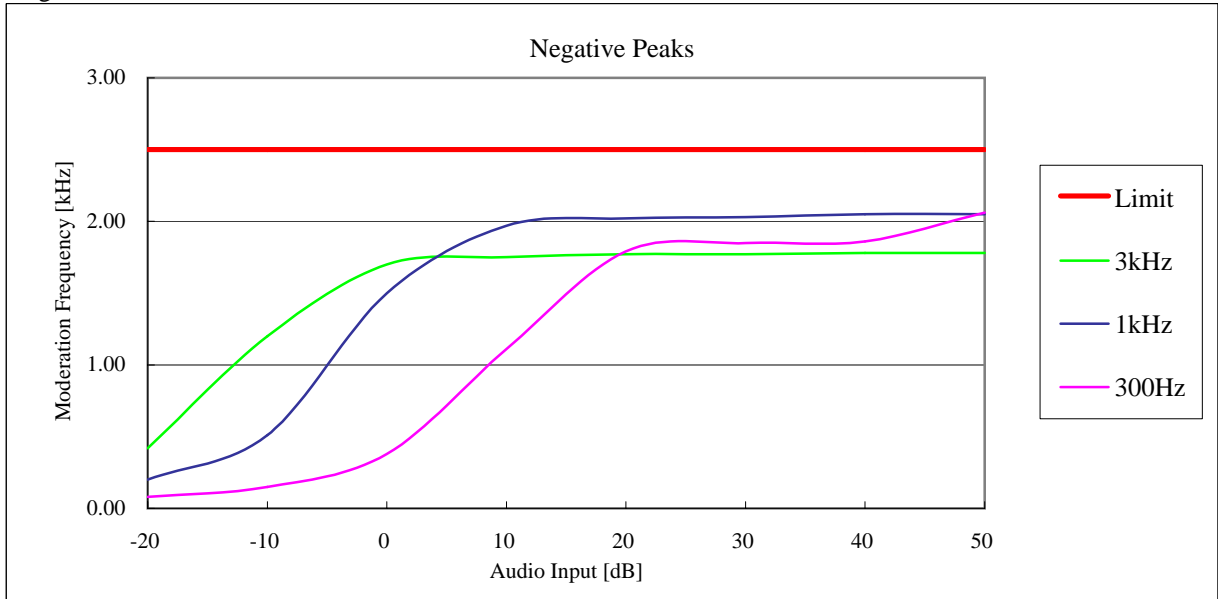

**4.8 Frequency Stability (Temperature Variation)**

REGULATIONS	: 47 CFR 2.1055 (a) (1), 90.213(a) / RSS-119 Section 7
TEST METHOD/GUIDE	: ANSI/TIA/EIA-603-1992, section 2.2.2.2 / RSS-119 Section 7

**TEST PROCEDURE**

- 1 The EUT and test equipment were set up as shown on the following page.
- 2 Set the temperature -30 degrees C.
- 3 Leave the EUT for 1 hour after it became the temperature that was set up.
- 4 Make the EUT the transmitting state.  
Two minutes later, measure the output frequency.
- 5 Make the EUT the receiving state.
- 6 Set the temperature 50 degrees C by 10 degrees C.  
And repeat test procedure 3 to 5.

**TEST EQUIPMENTS**

No.	Equipment	Manufacture	Model No.	Serial No.	Cal Exp.
1	Frequency Counter	ANRITSU	MF76A	MT27358	Sep-05
2	Attenuator (20dB)	Radiall	R414720161	03-16	Jul-05
3	Attenuator (30dB)	TME	CFA-100ANPJ-30	1008268	Jun-05
4	DC Power Supply	KIKUSUI	PAD35-30L	None	None
5	Temperature Chamber	TABAI	PL-3F	5103661	None
6	Temperature Meter	KIKUSUI	PC-5000TRH-II	A14999972	Apr-05

**MEASUREMENT EQUIPMENT CONFIGURATION**

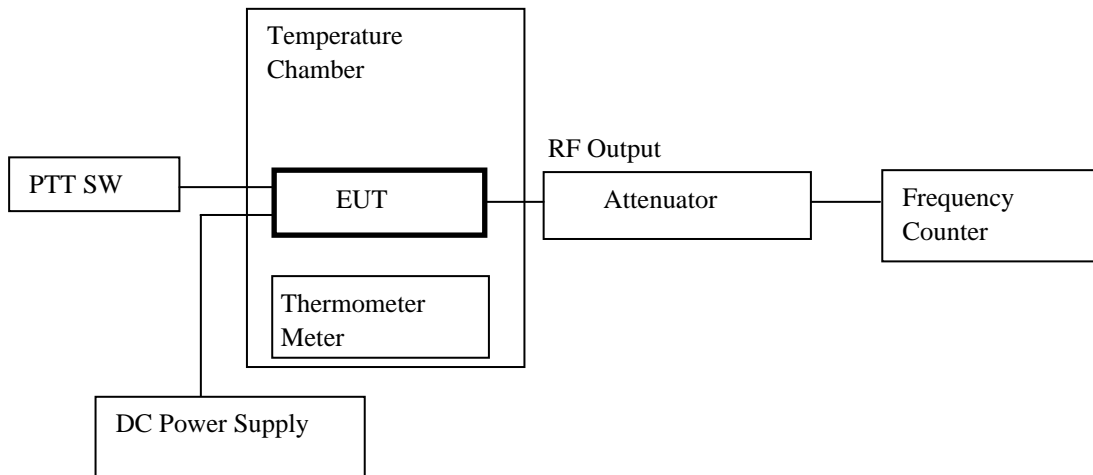

**UNCERTAINTY**

Measurement uncertainty is +/- 3.6%

**TEST RESULTS**

Measured for the worst case

State : High Power / Wide Modulation / 136.10 MHz

No.	Temperature (Degree C)	Frequency (MHz)	Deviation (ppm)	Spec (ppm)
1	-30	136.100018	0.13	2.5
2	-20	136.100015	0.11	2.5
3	-10	136.099981	-0.14	2.5
4	0	136.099985	-0.11	2.5
5	10	136.099968	-0.24	2.5
6	20	136.099980	-0.15	2.5
7	30	136.099939	-0.45	2.5
8	40	136.099932	-0.50	2.5
9	50	136.099950	-0.37	2.5

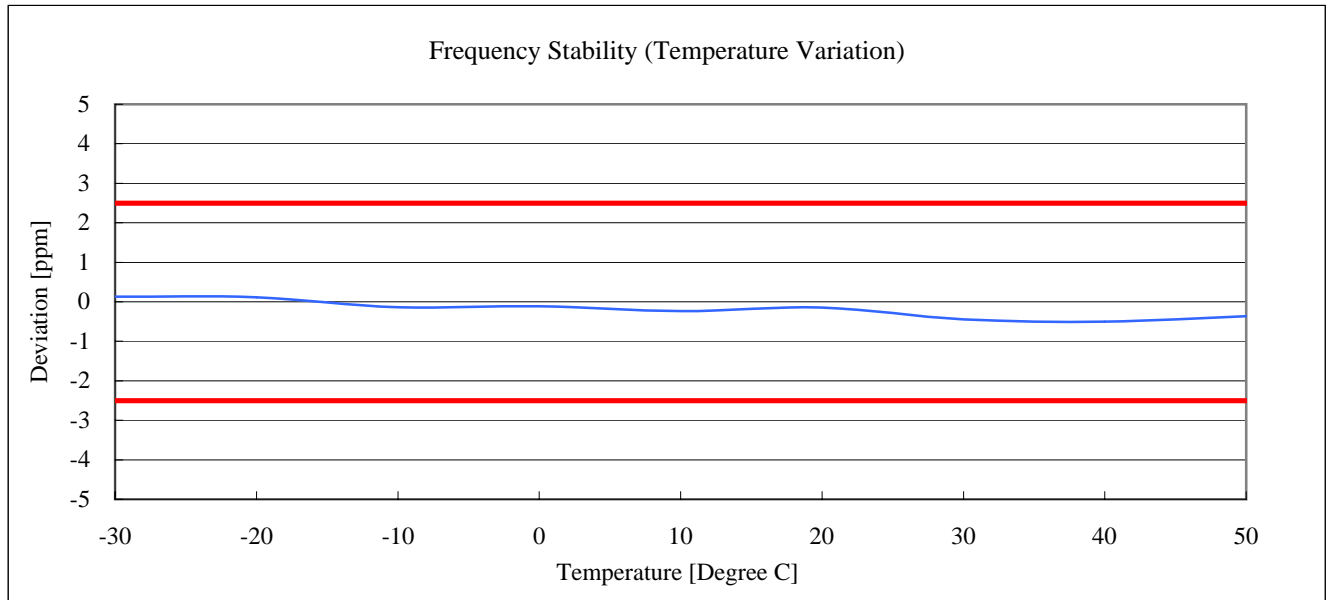

Note:

- 1 Spec stands for the specification of a device.
- 2 The limit value of mobile stations is frequency stability of 5ppm.



**4.9 Frequency Stability (Voltage Variation)**

REGULATIONS	: 47 CFR 2.1055 (d) (1), 90.213(a) / RSS-119 Section 7
TEST METHOD/GUIDE	: ANSI/TIA/EIA-603-1992, section 2.2.2.2 / RSS-119 Section 7

**TEST PROCEDURE**

- 1 The EUT and test equipment were set up as shown on the following page.
- 2 The power supply voltage to the EUT was varied from 85 % to 115 % of the nominal value measured at the input to the EUT.

**TEST EQUIPMENTS**

No.	Equipment	Manufacture	Model No.	Serial No.	Cal Exp.
1	Frequency Counter	ANRITSU	MF76A	MT27358	Sep-05
2	Attenuator (30dB)	TME	CFA-100ANPJ-30	1008268	Jun-05
3	Attenuator (20dB)	Radiall	R414720161	03-16	Jul-05
4	DC Power Supply	KIKUSUI	PAD35-30L	None	None

**MEASUREMENT EQUIPMENT CONFIGURATION**

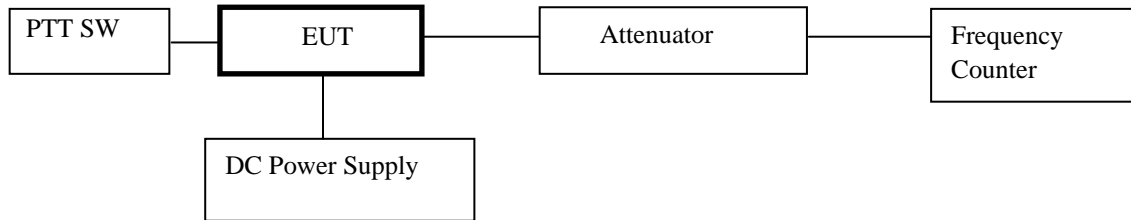

**UNCERTAINTY**

Measurement uncertainty is +/- 3.6%

**TEST RESULTS**

Measured for the worst case

State : High Power / Wide Band Modulation / 136.10 MHz

No.	Diviation (%)	Voltage (V)	Frequency (MHz)	Deviation (ppm)	Spec (ppm)
1	85	11.6	136.099930	-0.51	2.5
2	100	13.6	136.099937	-0.46	2.5
3	115	15.6	136.099945	-0.40	2.5

Note:

- 1 Spec stands for the specification of a device.
- 2 The limit value of mobile stations is frequency stability of 5ppm.

**4.10 Receiver Spurious Emissions(Radiated)**

REGULATIONS	: RSS-119, Section 8
TEST METHOD/GUIDE	: RSS-119, Section 8

**TEST PROCEDURE**

- 1 The EUT and test equipment were set up as shown on the following page.
- 2 Tabletop Equipment  
EUT is placed on the wooden table, the top of which is 0.8meter above the metal ground plane(turntable).
- 3 Interconnecting Cables  
Excess part of the interconnecting cables longer than 1 meter are bundled in the center.  
Cables that hang closer than 40 cm to the ground plane is folded back and forth forming bundle 30 to 40 cm long,
- 4 Measuring Instruments  
Measuring instruments list and their calibration schedule are shown on Measurement Equipment Configuration.  
The brief description are as follows;
- 5 Antennas  
The broadband Bi-cog antenna is used for measurement on the frequency range 30 – 1000 MHz.  
The Double ridged guide antenna is used for frequency higher than 1000 MHz
- 6 Pre-amplifier  
The broadband pre-amplifier is used for radiated emission measurement.  
The signal to noise ratio is improved by using pre-amplifier.
- 7 Spectrum Analyzer  
The spectrum analyzer is used for preliminary measurement of frequency range 30 – 1000 MHz, and also used for final measurement of higher than 1000 MHz (Resolution bandwidth : 1 MHz).
- 8 EMI Test Receiver  
The Quasi-peak detector (IF bandwidth : 120 kHz) built in test receiver is used for final measurement of the frequency 30 – 1000 MHz.  
The test receiver is complied with the specification of the CISPR publication 16.
- 9 Turntable  
The turntable is capable for EUT weight and rotatable 0 to 360 degree horizontally by remote control in the test room.
- 10 Antenna Mast  
The antenna mast is attachable to all antennas described on antenna height is adjustable 1 to 4 meters continuously by remote control at the test room, and antenna polarization is also changed by the remote control.  
Preliminary Measurement
- 11 EUT is tested on all operating conditions.  
The spectrum analyzer is set max-hold mode and swept during turntable was rotated 0 to 360 degree. Then spectrum chart are plotted out to find the worst emission conditions in configuration, operating mode, or ambient noise notation.

12 Final Measurement

The EUT operated in the condition where maximum emission is found in the preliminary test.

The turntable azimuth(EUT direction) and antenna height are adjusted the position so that maximum field strength is obtained for each frequency spectrum to be measured.

The equipment and cables are arranged or manipulated within the range of the test standard in the above condition.

When the uncertain result was obtained, the measurement is retried by using the half wave dipole antenna instead of the broadband antenna

**TEST EQUIPMENTS**

No.	Equipment	Manufacture	Model No.	Serial No.	Cal Exp.
1	Tri-log Antenna	Schwarzbeck	VULB9168	106	Feb-05
2	D.R.G Antenna	EMCO	3115	9612-5044	Jul-05
3	Step Attenuator	HP	8464B	2726A14513	Oct-04
4	Pre-Amplifier	HP	8447D	1937A03130	Oct-05
5	Pre-Amplifier	HP	83051A	3332A00329	Sep-05
6	Attenuator (6dB)	ANRITSU	MP721B	M57593	Oct-04
7	Attenuator (3dB)	Narda	3157846	4538	Sep-05
8	Spectrum Analyzer	HP	8564E	3643A00665	Aug-05
9	Test Receiver	Rohde & Schwarz	ESS	842123/005	Sep-05
10	Dummy Load	BIRD	8401	6163	Jul-05
11	DC Power Supply	DAIWA	PS-3020	None	None

**MEASUREMENT EQUIPMENT CONFIGURATION**

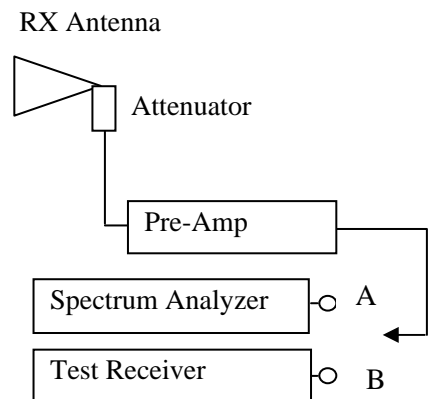
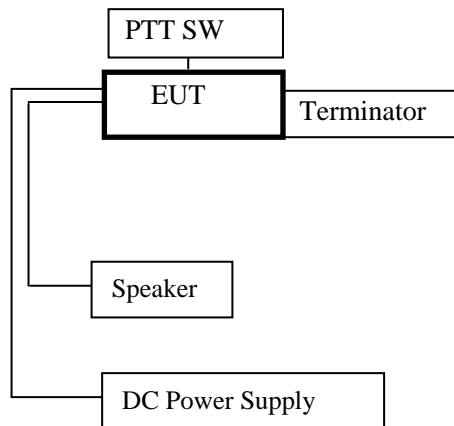

**UNCERTAINTY**

Measurement uncertainty is +/- 3.6dB (k = 2)

**TEST RESULTS**

Measured for the worst case

State : 173.90 MHz Receiver Condition

No.	Frequency (MHz)	Pol	Mode	Reading (dBuv)	Factor* (dB)	Emission (dBuV/m)	Limit (dBuV/m)	Margin (dB)
1	117.78	Hor.	QP	-	-	-	-	-
		Ver.	QP	29.00	-8.00	21.0	43.5	22.5
2	120.00	Hor.	QP	-	-	-	-	-
		Ver.	QP	26.20	-7.50	18.7	43.5	24.8
3	233.85	Hor.	QP	21.20	-7.20	14.0	46.0	32.0
		Ver.	QP	21.70	-7.20	14.5	46.0	31.5
4	348.21	Hor.	QP	-	-	-	-	-
		Ver.	QP	27.60	-3.50	24.1	46.0	21.9
5	467.80	Hor.	QP	-	-	-	-	-
		Ver.	QP	20.80	-0.30	20.5	46.0	25.5
6	935.60	Hor.	QP	-	-	-	-	-
		Ver.	QP	19.70	9.60	29.3	46.0	16.7
7	1738.93	Hor.	PK	39.80	1.20	41.0	74.0	33.0
		Ver.	PK	40.10	1.20	41.3	74.0	32.7
		Hor.	AV	28.40	1.20	29.6	54.0	24.4
		Ver.	AV	28.50	1.20	29.7	54.0	24.3

There is the margin of 20dB over except for the above points.

\* Factor = Antenna, Antenna Pad, Cable, Preamp

Emission Level = Reading Level + Factor

Note:

- 1 Measurement distance is 3 metres.
- 2 Scanned frequency are 30 to 2000 MHz.
- 3 Maximum local oscillator frequency is 50.4MHz.

**4.11 Necessary Bandwidth and Emission Bandwidth**

REGULATIONS	: 47 CFR 2.202 (g) & Federal Register/ Vol.68, No236
-------------	--

**CALCULATION RESULTS**

State : 16K0F3E(25kHz channel bandwidth)

Item	Mark	
Maximum Modulation	(M)	3kHz
Maximum Deviation	(D)	5kHz
Constant Factor	(K)	1
Necessary Bandwidth	(Bn)	16kHz

$$B_n = (2 \times M) + (2 \times D \times K)$$

State : 11K0F3E(12.5kHz channel bandwidth)

Item	Mark	
Maximum Modulation	(M)	3kHz
Maximum Deviation	(D)	2.5kHz
Constant Factor	(K)	1
Necessary Bandwidth	(Bn)	11kHz

$$B_n = (2 \times M) + (2 \times D \times K)$$

## 5. VALIDITY OF TEST REPORT

The test result of this report is effective for equipment under test itself and under the test configuration described on the report.

This test report does not assure that whether the test result taken in other testing laboratory is compatible or reproducible to the test result on this report or not.

Copying of this report without permission is prohibited.

## 6. DESCRIPTION OF TEST LABORATORY

ACCREDITATION		SCOPE	LAB. CODE
NVLAP	USA	EMC Testing	100290-0
NVLAP	USA	Calibration	100290-0
NVLAP	USA	Telecommunication	100290-0
VLAC	JAPAN	EMC Testing	VLAC-008
BSMI	TAIWAN	EMC Testing	SL2-IN-E-6008
NATA	AUSTRALIA	Calibration	13491
NATA	AUSTRALIA	Telecommunication	100290-0

AUTHORIZATION		SCOPE	LAB. CODE
NEMKO	NORWAY	EMC Testing	ELA107
ETL SEMKO JAPAN	SWEDEN	EMC Testing	9200202558R

FILING		SCOPE	LAB. CODE
FCC	USA	EMC Testing	90433,90434
IC	CANADA	EMC Testing	IC-2065
IC	CANADA	Telecommunication	IC-2065
VCCI	JAPAN	EMC Testing	

Note 1 : NVLAP accreditation does not constitute any product endorsement by NVLAP or any agent of the U.S. Government.