



TEST REPORT

REGULATION :

FCC Part 2, 22, 74, 90, 90.210

Applicant	Testing Laboratory
Kenwood Corporation 1-16-2, Hakusan, Midori-ku, Yokohama-shi Kanagawa, 226-8525 Japan Tel.: +81 45 939 6254 Fax.: +81 45 939 7097	Intertek Japan K. K. Kashima No.1 Test site FCC Designation Number : JP0008 3-2, Sunayama, Kamisu-shi, Ibaraki-ken 314-0255 Japan Tel.: +81 479 40 1097 Fax.: +81 479 46 1788 URL: www.japan.intertek-etlsemko.com

Equipment type	UHF DIGITAL BASE-REPEATER
Trademark	KENWOOD
Model(s)	NXR-800-K5
Serial No.	None
FCC ID	K44371404
Measurement Method	ANSI/TIA-603-C-2004
Deviation from standard(s)	No deviation
Test Result	Complied
Report Number	JA08010030
Report issue date	March 04, 2008

This equipment has been shown to be capable of compliance with the applicable standard(s) as indicated in the test report.

I attest to the accuracy of data. All measurements reported herein were performed by me or were made under my supervision and are correct to the best of my knowledge and belief. I assume full responsibility for the completeness of these measurements and vouch for the qualifications of all persons taking them.

This test report shall not be reproduced partially, or in full, without the prior written approval of Intertek Japan K. K. The results and statements contained in this report pertain only to the equipment evaluated.

Approved by

Junichi Okada

[Site Manager]

Tested by

Kazuo Masuda

TABLE OF CONTENTS

	Page
SECTION 1. GENERAL INFORMATION	3
SECTION 2. TEST AND MEASUREMENT DATA	5
SECTION 3. INFORMATION ABOUT EUT AND SUPPORT EQUIPMENT(S)	6
SECTION 4. MEASUREMENT RESULT	9
SECTION 5. TEST DATA	
5.1 Carrier Output Power (Conducted)	10
5.2 Unwanted Emissions (Transmitter Conducted)	12
5.3 Field Strength of Spurious Radiation	15
5.4 Emission Masks (Occupied Bandwidth)	19
5.5 Transient Frequency Behavior	25
5.6 Audio Frequency Response / Audio Low Pass Filter (Voice Input)	30
5.7 Modulation Limiting	33
5.8 Frequency Stability (Temperature Variation)	37
5.9 Frequency Stability (Voltage Variation)	40
5.10 Necessary Bandwidth and Emission Bandwidth	42
SECTION 6. VALIDITY OF TEST REPORT	44
SECTION 7. DESCRIPTION OF TEST SITE	44
APPENDIX PHOTOGRAPHS	

SECTION 1. GENERAL INFORMATION

Description of Test Item	
Kind of EUT	: UHF DIGITAL BASE-REPEATER
Condition of EUT	: Prototype
Type	: Rack Mount type
Trademark	: KENWOOD

Test Performed	
EUT Received	: January 28, 2008
Test started	: January 29, 2008
Test completed	: February 26, 2008
Temperature	: 20 to 24 degree C
Humidity	: 30 to 47 %
Atmospheric	: 101.0 to 102.4 kPa
Voltage	: DC 13.8 V
Current	: 7.5A Maximum
Frequency	: None

Test Tracability
Tracability to national standards of test result is achieved by means of calibration tractability to national or international standards.

Abbreviations	
EUT = Equipment Under Test	Cal Exp. = Calibration Expire
D.R.G. Antenna = Double Rigid Guide Antenna	RBW = Resolution Band Width
AVG = Average	VBW = Video Band Width

In Accordance with FCC Rules and Regulations, Volume II, Part 2 and 90

Sub-part 2.1033

(c)(1) Applicant and Manufacture Information	
APPLICANT	
Company	: Kenwood Corporation
Address	: 1-16-2, Hakusan, Midori-ku, Yokohama-shi, Kanagawa, 226-8525 Japan
Contact Person	: Tamaki Shimamura Manager, Communications Equipment Division
MANUFACTURER	
Company	: Kenwood Corporation
Address	: 1-16-2, Hakusan, Midori-ku, Yokohama-shi, Kanagawa, 226-8525 Japan
(c)(2) FCC ID	
FCC ID	: K44371404
Model number	: NXR-800-K5
Serial number	: None
(c)(3) Instruction Manual(S)	
Instruction manual(s)	: Please refer to attached Exhibits F
(c)(4) Type of Emission	
Emission Designation	: 16K0F3E (Wide) / 11K0F3E (Narrow) 8K30F1E (Narrow) / 8K30F1D (Narrow) / 8K30F7W (Narrow) 4K00F1E (Very Narrow) / 4K00F1D (Very Narrow) / 4K00F7W (Very Narrow) 4K00F2D (Very Narrow)
(c)(5) Frequency range	
Frequency Range	: 477 to 512 MHz (CFR)
(c)(6) Power Rating	
Output Power	: 0.5 to 5 W
Type	: Continuously Variable
(c)(7) Maximum Power Rating	
Output Power	: 5 W
Other Information	
Number of Channel	: 30
Maximum Deviation	: 5 kHz / 2.5 kHz
Frequency Stability	: 0.5 ppm (with KXX-3 OCXO Unit : Specification)
Antenna Impedance	: 50 Ω Norminal
Note	

SECTION 2. TEST AND MEASUREMENT DATA

All test and measurements indicated in this document were performed in accordance with the Code of Federal Regulations Title 47 Part 2, Sub-part J and Industry Canada as the following individual parts:

FCC Rule	Test Item	Tested
Part 21	Domestic Public Fixed radio Services	N.A.
Part 22	Non Cellular	YES
Part 22	Public Mobile Services	N.A.
Part 22	Subpart H - Cellular Radiotelephone Service	N.A.
Part 22	Alternative technologies and auxiliary service	N.A.
Part 23	International Fixed Public Radiocommunication service	N.A.
Part 24	Personal Communications Services	N.A.
Part 74	Subpart H - Low Power Auxiliary Stations	YES
Part 80	Stations in the Maritime Services	N.A.
Part 80	Subpart E - general Technical Standards	N.A.
Part 80	Subpart F - Equipment Authorization for Compulsory Ships	N.A.
Part 80	Subpart K - Private Coast Stations and Marine Utility Stations	N.A.
Part 80	Subpart S - Compulsory radiotelephone Installations for Small Passenger Boats	N.A.
Part 80	Subpart T - Radiotelephone Installation Required for Vessels on the Great Lakes	N.A.
Part 80	Subpart U - Radiotelephone Installations Required by the Bridge-to-Bridge Act	N.A.
Part 80	Subpart V - Emergency Position Indicating Radiobeacons (EPIRB'S)	N.A.
Part 80	Subpart W - Global Maritime Distress and Safety System (GMDSS)	N.A.
Part 80	Subpart X - Voluntary Radio Installations	N.A.
Part 87	Aviation Services	N.A.
Part 90	Private Land Mobile radio Services	YES
Part 94	Private Operational - Fixed Microwave Service	N.A.
Part 95	Subpart A - General Mobile radio Service	N.A.
Part 95	Subpart C - Radio Control (R/C) radio Service	N.A.
Part 95	Subpart D - Citizens Band (CB) Radio Service	N.A.
Part 95	Subpart E -Family radio Service	N.A.
Part 95	Subpart F -Interactive Video and Data Service (IVDS)	N.A.
Part 97	Amateur Radio Service	N.A.
Part 101	Fixed Microwave Service	N.A.

IC Rule	Test Item	Tested
RSS-119	Land Mobile and Fixed Radio Transmitters and Receivers	N.A.
RSS-Gen	General Requirements and Information for the Certification of Radiocommunication Equipment	N.A.

SECTION 3. INFORMATION ABOUT EUT AND SUPPORT EQUIPMENT(S)

List of System Configuration

Symbol	Item	Model No.	Serial No.	Manufacture	Notes
A1	UHF DIGITAL BASE-REPEATER	NXR-800-K5	None	Kenwood	EUT
A2	OCXO Unit	KXK-3	None	Kenwood	EUT

Port(s)/Connector(s)

Port Name	Connector Type	Connector Pin	Notes
RX	BNC	2 pin	
REF OUT	BNC	2 pin	
REF IN	BNC	2 pin	
DC IN	JST VLR-02V	2 pin	
TX	BNC	2 pin	
TEST/SPKR	MOLEX 1625-15p	15 pin	
Control I/O	D-sub	25 pin	
SYNC 1	RJ-11	4 pin	
SYNC 2	RJ-11	4 pin	
LAN	RJ-45	8 pin	
Microphone	RJ-45	8 pin	
COM	D-sub	9 pin	

Support Equipment(s)

Symbol	Item	Model No.	Serial No.	Manufacture	FCC ID
B	Microphone	KMC-35	None	Kenwood	N/A
C	Hub	SD205	REF10FC08890 GEB1046 PP	LINKSYS	DoC
D	Modem	Tuff-Modem	700865	Trident Micro Systems	N/A
E	Controller	None	None	None	N/A
F	External Speaker	KES-5	None	Kenwood	N/A
G	Terminator	CT-150NP	None	TME	N/A
H	Base-Repeater (1)	NXR-700-K	None	Kenwood	N/A
I	Base-Repeater (2)	NXR-JIG	None	Kenwood	N/A
J	DC Power Supply	PS-3020	None	Daiwa	N/A
K	DC Power Supply	10A	None	Mickey	N/A
L	AC Adapter	D12-50-A	R060915	LINKSYS	N/A
M	Terminator	CT-01	None	TME	N/A
N	Terminator	CT-01	None	TME	N/A
O	Terminator	N-TMP-10	None	HRS	N/A
P	Terminator	None	None	None	N/A
Q	Terminator	DL-30N	None	Diamond Antenna	N/A

Used Cable(s)

No.	Name	Length (m)	Shield	Notes
1	Mic. Cable	0.60	Plastic	
2	LAN Cable	1.00	Plastic	
3	RS-232C Cable	1.00	Shield	
4	D-sub Cable	1.20	Shield	
5	Speaker Cable	2.80	Plastic	
6	ANT Cable	0.90	Shield	
7	Modular Cable	0.30	Plastic	
8	Modular Cable	0.30	Plastic	
9	DC Cable for EUT (A1)	4.00	Plastic	Removable x 1
10	DC Cable for Base-Repeater (H)	4.00	Plastic	Removable x 1
11	DC Cable for Base-Repeater (I)	4.00	Plastic	Removable x 1
12	Power Cable for DC Power Supply (J)	1.70		
13	DC Cable for Modem	1.50		
14	Power Cable for DC Power Supply (K)	1.60		
15	DC Cable for HUB	2.00		
16	Coaxial Cable	1.00	Shield	
17	Coaxial Cable	0.90	Shield	

Details of Configuration and Connection
 Example: Case of Section 5.3 Radiation Test

* :EUT
 ■ :Core

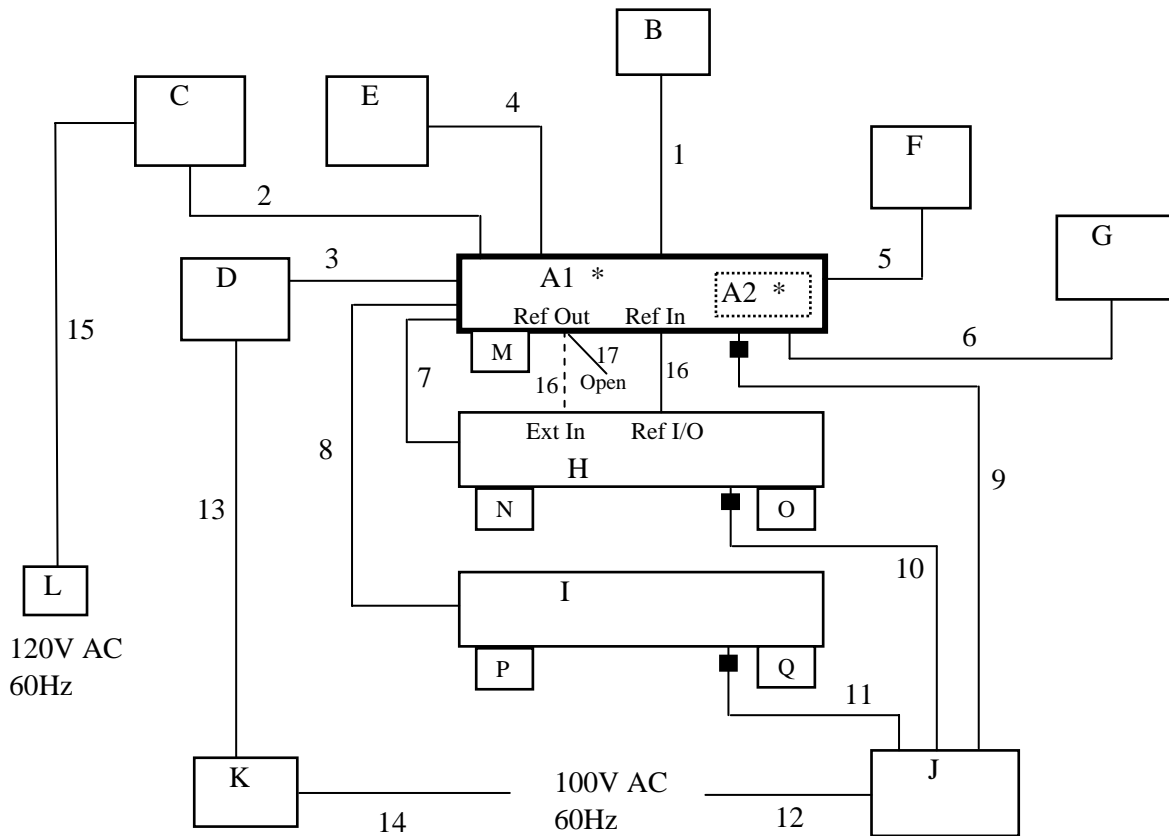

The EUT was operated under the following modes in the dotted line frame.

- Built In mode : Connect Cable No.16 between Ref Out (A1) and Ext In (H) port.
- External mode : Connect Cable No.16 between Ref In (A1) and Ref I/O (H) port.
- Connect Cable No.17 for Ref Out (A1) port.

SECTION 4. MEASUREMENT RESULT

FCC Part2	Part22	Part74	Part90	TEST ITEM	RESULTS
2.1046 (a)	-	-	-	Carrier Output Power (Conducted)	PASS
2.1051	-	-	90.210	Unwanted Emissions (Transmitter Conducted)	PASS
2.1053 (a)	-	-	90.210	Field Strength of Spurious Radiation	PASS
2.1049 (c) (1)	22.359, 357 (a) (1)	74.1236	90.210	Emission Masks (Occupied Bandwidth)	PASS
-	-	-	90.214	Transient Frequency Behavior	PASS
2.1047 (a)	-	-	90.242 (b) (8)	Audio Low Pass Filter (Voice Input)	PASS
2.1047 (a)	-	-	-	Audio Frequency Response	PASS
2.1047 (b)	-	-	-	Modulation Limiting	PASS
2.1055 (a) (1)	22.355	74.1261 (b)	90.213 (a)	Frequency Stability (Temperature Variation)	PASS
2.1055 (d) (1)	22.355	74.1261 (b)	90.213 (a)	Frequency Stability (Voltage Variation)	PASS

Limitation on Results

The test result of this report is effective equipment under test itself and under the test configuration described on the report. This test report dose not assure that whether the test result taken in other testing laboratory is compatible or reproducible to the test result on this report or not.

SECTION 5. TEST DATA

5.1 Carrier Output Power (Conducted)

REGULATIONS	: 47 CFR 2.1046 (a)
TEST METHOD/GUIDE	: ANSI/TIA-603-C Section 2.2.1.2

Test Procedure

- The EUT and test equipment were set up as shown on the following page.
- The EUT was conducted to a resistive coaxial attenuator of normal load impedance.
 $RF\ Power\ (dBm) = Power\ Meter\ reading\ (dBm) + Attenuator\ Loss\ (dB) + Cable\ Loss\ (dB)$
 $RF\ Power\ (W) = 10^{(RF\ Power\ (dBm)/10)}/1000$
- Modulate the transmitter with a 2.5 kHz sine wave at an input Level of 16 dB greater than that necessary to produce 50 % of rated system deviation.

Measuring Equipments

No.	Equipment	Manufacture	Model No.	Serial No.	Cal Date	Cal Exp.
1	Power Meter	Hewlett Packard	E4418B	GB38410265	May 17, 07	May 31, 08
2	Power Sensor	Hewlett Packard	8482A	US37292237	May 09, 07	May 31, 08
3	Attenuator (30dB)	Weinschel	WA-29-30-34	8923	Jun. 19, 07	Jun. 30, 08
4	Audio Generator	Anritsu	MG443B	M70150	Jul. 24, 07	Jul. 31, 08
5	Digital Multi Meter	Sanwa	CD721	3215593	Jun 20, 07	May 31, 08
6	DC Power Supply	Daiwa	PS-3020	None	None	None

Measuring Cables

No.	Cable	Manufacturer	Model No.	Serial No.	Cal Date	Cal Exp.
W1	Coaxial Cable	Suhner	SUCOFLEX102	KSR00091	Mar. 22, 07	Mar. 31, 08
W2	Balance Cable	Nicoon	3D-2V	KSR00092	Oct. 16, 07	Oct. 31, 08

Measuring Equipment Configuration

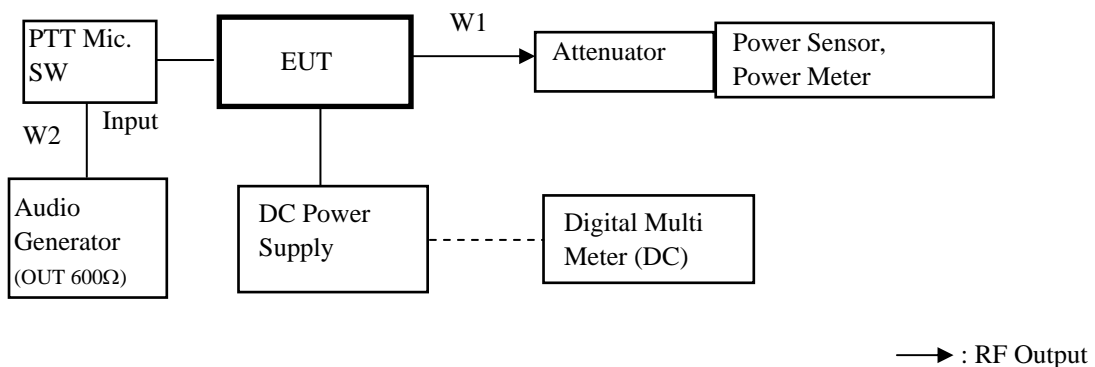

Uncertainty

Measurement uncertainty is +/- 0.5dB (k = 2)

Test Results

Measured for the worst case

No.	Frequency (MHz)	Band	Setting	RF Power (W)
1	477.10	Low	High Power	5.0
2	494.60	Middle	High Power	5.0
3	511.90	High	High Power	5.0
4	477.10	Low	Low Power	0.5
5	494.60	Middle	Low Power	0.5
6	511.90	High	Low Power	0.5

5.2 Unwanted Emissions (Transmitter Conducted)

REGULATIONS	: 47 CFR 2.1051, 90.210
TEST METHOD/GUIDE	: ANSI/TIA-603-C Section 2.2.13.2

Test Procedure

- 1 The EUT and test equipment were set up as shown on the following page.
- 2 Modulate the transmitter with a 2.5 kHz sine wave at an input Level of 16 dB greater than that necessary to produce 50 % of rated system deviation.
- 3 Adjust the spectrum analyzer for the following setting:
 - a) RBW : 10 kHz (< 1 GHz), 1 MHz (> 1 GHz).
 - b) VBW : 30 kHz (< 1 GHz), 3 MHz (> 1 GHz).
 - c) Sweep Speed : 50 msec.
 - d) Detector mode : Average
- 4 The emissions were measured for the worst case as follows:
 - a) : within a band of frequencies defined by the carrier frequency plus and minus one channel.
 - b) : from the lowest frequency generated in the EUT and to at least the 10th harmonic of the carrier frequency, or 40 GHz, whichever is lower.

Measuring Equipments

No.	Equipment	Manufacture	Model No.	Serial No.	Cal Date	Cal Exp.
1	Audio Generator	Anritsu	MG443B	M70150	Jul. 24, 07	Jul. 31, 08
2	Attenuator (30dB)	Weinschel	WA-29-30-34	8923	Jun. 19, 07	Jun. 30, 08
3	Modulation Analyzer	Hewlett Packard	8901B	2806A01669	Mar. 21, 07	Mar. 31, 08
4	Signal Generator	Rohde&Schwarz	SMT03	841733/010	May. 08, 07	May. 31, 08
5	Signal Generator	Rohde&Schwarz	SMR40	834128/0028	May. 01, 07	May. 31, 08
6	Spectrum Analyzer	Agilent	E4407B	MY45102460	Jan 09, 08	Jan. 31, 09
7	Highpass Filter	Anritsu	MP526B	6200220636	Aug. 16, 07	Aug. 31, 08
8	DC Power Supply	Daiwa	PS-3020	None	None	None
9	Digital Multi Meter	Sanwa	CD721	3215593	May 18, 07	May. 31, 08

Measuring Cables

No.	Cable	Manufacturer	Model No.	Serial No.	Cal Date	Cal Exp.
W1	Coaxial Cable	Suhner	SUCOFLEX102	KSR00091	Mar. 22, 07	Mar. 31, 08
W2	Coaxial Cable	Pacific custom	RG-58 C/U	AM90C03	Aug. 31, 07	Aug. 31, 08
W3	Coaxial Cable	Pacific custom	RG-58 C/U	KSR00041	Aug. 30, 07	Aug. 31, 08
W4	Coaxial Cable	Pacific custom	RG-58 C/U	KSR00093	Aug. 31, 07	Aug. 31, 08
W5	Balance Cable	Nicoon	3D-2V	KSR00092	Oct. 16, 07	Oct. 31, 08

Measuring Equipment Configuration

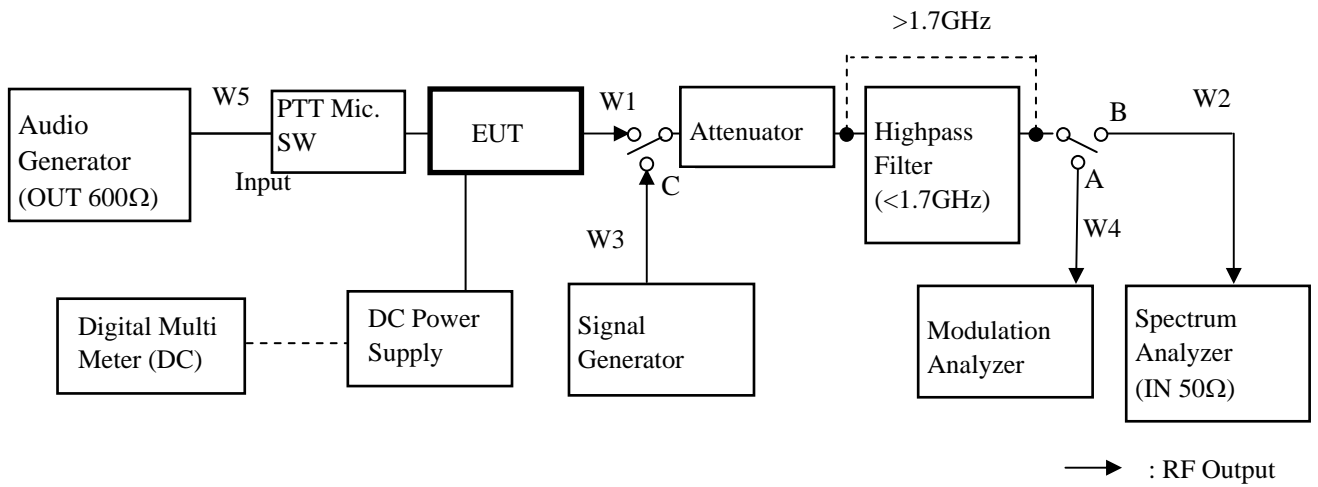

Uncertainty

Measurement uncertainty is +/- 1.5 dB (k = 2)

Test Results

Measured for the worst case

State : High Power / Authorized Bandwidth 6 kHz

No.	Band	Frequency (MHz)	Correct Level (dBm)	Emission Level (dBc)	Limit (dBc)	Margin (dB)
1	Low	954.20	-44.61	-81.60	-62.0	19.6
2	Middle	989.20	-51.01	-88.00	-62.0	26.0
3	High	1023.80	-52.81	-89.80	-62.0	27.8

There is the margin of 20dB over except for the above points.

State : Low Power / Authorized Bandwidth 6 kHz

No.	Band	Frequency (MHz)	Correct Level (dBm)	Emission Level (dBc)	Limit (dBc)	Margin (dB)
1	Low	954.20	-49.60	-76.59	-52.0	24.6
2	Middle	989.20	-56.36	-83.35	-52.0	31.4
5	High	1023.80	-57.41	-84.40	-52.0	32.4

There is the margin of 20dB over except for the above points.

Mask E Limit (dBc) = $-(55+10\text{Log}(P))$

Correct Level (dBm) = Substitute SG Level (dBm)

Emission Level (dBc) = Correct Level (dBm) - $10\text{Log}(P*1000)$

P = Carrier Level (W)

" - " = Measurement Limit

5.3 Field Strength of Spurious Radiation

REGULATIONS	: 47 CFR 2.1053 (a), 90.210
TEST METHOD/GUIDE	: ANSI/TIA-603-C Section 2.2.12.2

Test Procedure

- 1 The EUT and test equipment were set up as shown on the following page.
- 2 Adjust the spectrum analyzer for the following setting:
 - a) RBW : 10 kHz (< 1 GHz), 1 MHz (> 1 GHz).
 - b) VBW : 300 kHz (< 1 GHz), 3 MHz (> 1 GHz).
 - c) Sweep Speed : 50ms.
 - d) Detector mode : Positive Peak
- 3 The transmitter was placed on a wooden turntable, and it was transmitting into non-radiating load which was also placed on the turntable.
- 4 The measurement antenna was placed at a distance of 3 meters from the EUT.
 During the tests, the antenna height and polarization as well as EUT azimuth were varied in order to identify the maximum level of emissions from the EUT.
 The test was performed by placing the EUT on 3-orthogonal axis.
- 5 The frequency range up to tenth harmonic of the fundamental frequency was investigated.
- 6 Remove the EUT and replace it with substitution antenna. A signal generator was connected to the substitution antenna by a non-radiating cable.
 The absolute levels of the spurious emissions were measured by the substitution.
- 7 Spurious emissions in dB = 10 Log (TX power in Watts/0.001) – the absolute level

Measuring Equipments

No.	Equipment	Manufacture	Model No.	Serial No.	Cal Date	Cal Exp.
1	Dipole Antenna(TX)	Schwarzbeck	VHA9103	C01082007	Apr. 05, 07	Apr. 30, 08
2	Dipole Antenna(TX)	Schwarzbeck	UHA9105	AM0082002	Apr. 05, 07	Apr. 30, 08
3	D.R.G Antenna(TX)	Schwarzbeck	3115	5045	Jun. 21, 07	Jun. 30, 08
4	Tri-log Antenna(RX)	Schwarzbeck	VULB9168	106	Jun. 14, 07	Jun. 30, 08
5	D.R.G Antenna(RX)	Schwarzbeck	3115	5044	Jun. 21, 07	Jun. 30, 08
6	Pre-Amplifier	Hewlett Packard	83051A	3332A00329	Oct. 11, 07	Oct. 31, 08
7	Step Attenuator	Hewlett Packard	8494B	2726A14513	Nov. 30, 07	Nov. 30, 08
8	Attenuator(6dB)	Anritsu	MP721B	M57593	Nov. 30, 07	Nov. 30, 08
9	Attenuator(3dB)	Narda	4768-3	79	Oct. 11, 07	Oct. 31, 08
10	Attenuator(10dB)	HUBER+SUHNER	6810.17B	KSR0044	Sep. 10, 07	Sep. 30, 08
11	Spectrum Analyzer	Agilent	E4407B	MY45102460	Jan. 09, 08	Jan. 31, 09
12	Signal Generator	Rohde&Schwarz	SMT03	841733/010	May 08, 07	May 31, 08
13	Signal Generator	Rohde&Schwarz	SMR40	834128/0028	May 01, 07	May 31, 08
14	Dummy Load	TME	CT-150NP	1138693	Aug. 31, 07	Aug. 31, 08
15	Digital Multi Meter	Sanwa	CD721	3215593	May. 18, 07	May. 31, 08
16	DC Power Supply(1)	Daiwa	PS-3020	None	None	None
17	DC Power Supply(2)	Mickey	10A	None	None	None

Measuring Cables

No.	Cable	Manufacturer	Model No.	Serial No.	Cal Date	Cal Exp.
W8	Coaxial Cable	Suhner	SUCOFLEX100	KSR00046	Aug. 16, 07	Aug. 31, 08
W9	Coaxial Cable	Radiall	R286401332	KSR00048	Aug. 16, 07	Aug. 31, 08
R1	Coaxial Cable	Intertek Japan	5D-2W	None	Nov. 30, 07	Nov. 30, 08
R2	Coaxial Cable	Intertek Japan	10D-2W	None	Nov. 30, 07	Nov. 30, 08
R3	Coaxial Cable	Intertek Japan	5D-2W	None	Nov. 30, 07	Nov. 30, 08
R7	Coaxial Cable	Intertek Japan	5D-2W	None	Nov. 30, 07	Nov. 30, 08
R14	Coaxial Cable	Suhner	SUCOFLEX102	712/2	Oct. 11, 07	Oct. 31, 08
R15	Coaxial Cable	Insulated Wire	KSP-1501-1969- KPS	03292004	Oct. 11, 07	Oct. 31, 08

Measuring Equipment Configuration

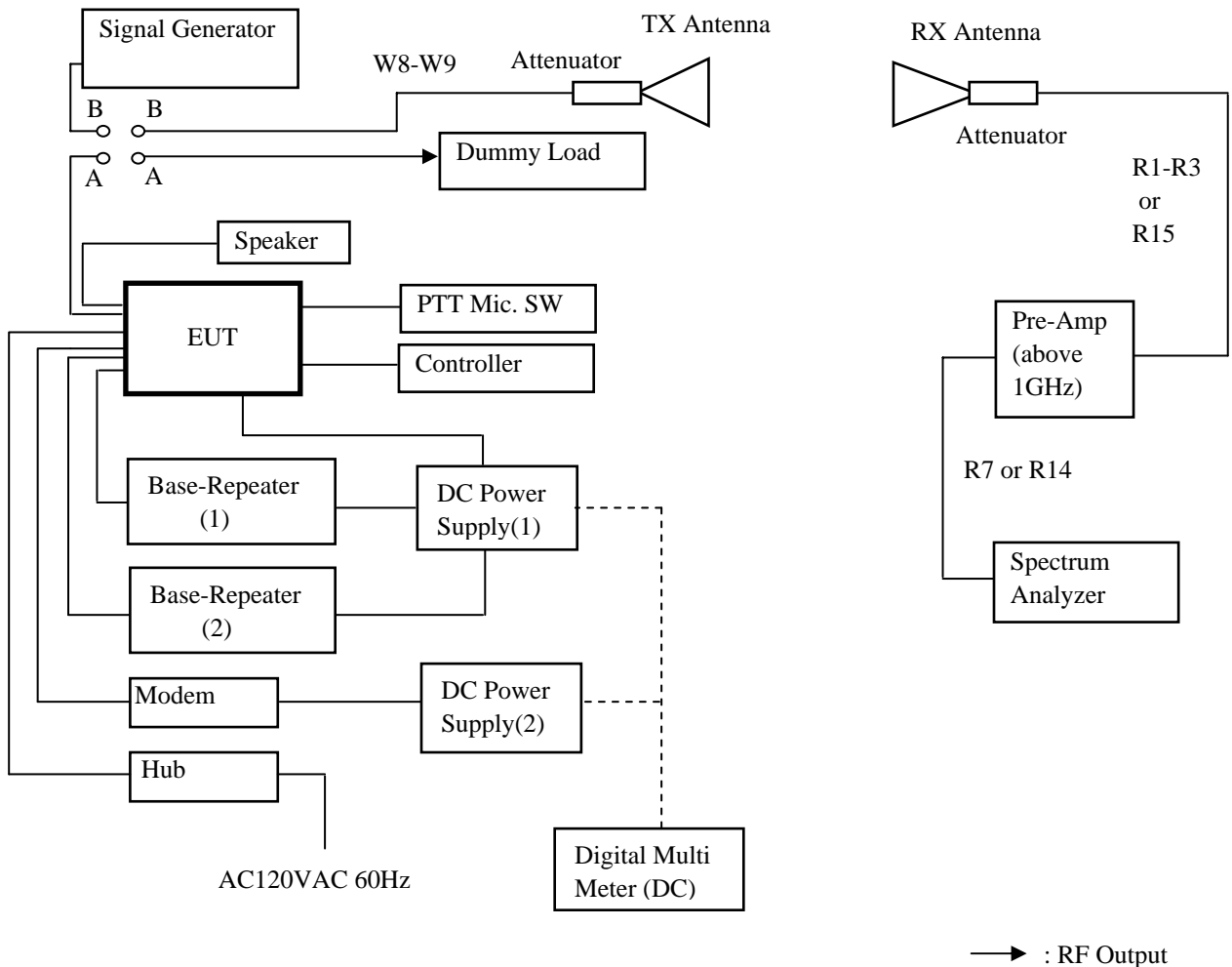

Uncertainty

Measurement uncertainty is +/- 4.8dB (k = 2)

Test Results

Test carried out for all the frequency band of section 5.1
 Measured for the worst case

State : High Power / Authorized Bandwidth 6 kHz / 494.6 MHz

No	Frequency (MHz)	Pol	Reading Level (dBm)	SG Out Level (dBm)	Loss (dB)	Antenna Gain (dBi)	Correct Level (dBm)	Emission Level (dBc)	Limit Level (dBc)	Margin (dB)
1	989.20	Hor.	-63.65	-28.50	12.59	2.15	-38.9	-75.9	-62.0	13.9
		Ver.	-64.05	-27.00	12.59	2.15	-37.4	-74.4	-62.0	12.4
2	1483.80	Hor.	-66.59	-54.40	13.19	8.45	-59.1	-96.1	-62.0	34.1
		Ver.	-58.48	-47.80	13.19	8.45	-52.5	-89.5	-62.0	27.5
3	1978.40	Hor.	-59.93	-47.50	13.75	8.91	-52.3	-89.3	-62.0	27.3
		Ver.	-59.30	-46.90	13.75	8.91	-51.7	-88.7	-62.0	26.7
4	2473.00	Hor.	-60.96	-47.20	14.18	9.88	-51.5	-88.5	-62.0	26.5
		Ver.	-61.05	-43.50	14.18	9.88	-47.8	-84.8	-62.0	22.8
5	2967.60	Hor.	-60.49	-43.70	14.62	9.96	-48.4	-85.4	-62.0	23.4
		Ver.	-62.04	-38.10	14.62	9.96	-42.8	-79.8	-62.0	17.8
6	3462.20	Hor.	-	-	13.20	10.07	-	-	-	-
		Ver.	-	-	13.20	10.07	-	-	-	-
7	3956.80	Hor.	-	-	13.43	9.85	-	-	-	-
		Ver.	-	-	13.43	9.85	-	-	-	-
8	4451.40	Hor.	-	-	13.63	11.18	-	-	-	-
		Ver.	-	-	13.63	11.18	-	-	-	-
9	4946.00	Hor.	-	-	13.84	11.25	-	-	-	-
		Ver.	-	-	13.84	11.25	-	-	-	-

There is the margin of 20dB over except for the above points.

Mask E Limit (dBc) = $-(55+10\log(P))$

Correct Level (dBm) = Substitute SG Level (dBm) + ANT Gain (dBi) - Loss (Cable, Attenuator) (dB)

Emission Level (dBc) = Correct Level (dBm) - $10\log(P*1000)$

P = Carrier Level (W)

" - " = Measurement Limit

State : Low Power / Authorized Bandwidth 6 kHz / 494.6 MHz

No	Frequency (MHz)	Pol	Reading Level (dBm)	SG Out Level (dBm)	Loss (dB)	Antenna Gain (dBi)	Correct Level (dBm)	Emission Level (dBc)	Limit Level (dBc)	Margin (dB)
1	989.20	Hor.	-63.70	-28.60	12.59	2.15	-39.0	-66.0	-52.0	14.0
		Ver.	-64.50	-27.80	12.59	2.15	-38.2	-65.2	-52.0	13.2
2	1483.80	Hor.	-68.59	-55.10	13.19	8.45	-59.8	-86.8	-52.0	34.8
		Ver.	-60.48	-48.10	13.19	8.45	-52.8	-79.8	-52.0	27.8
3	1978.40	Hor.	-60.93	-48.80	13.75	8.91	-53.6	-80.6	-52.0	28.6
		Ver.	-60.30	-48.30	13.75	8.91	-53.1	-80.1	-52.0	28.1
4	2473.00	Hor.	-64.96	-53.30	14.18	9.88	-57.6	-84.6	-52.0	32.6
		Ver.	-65.05	-50.10	14.18	9.88	-54.4	-81.4	-52.0	29.4
5	2967.60	Hor.	-63.49	-47.10	14.62	9.96	-51.8	-78.8	-52.0	26.8
		Ver.	-63.04	-40.70	14.62	9.96	-45.4	-72.4	-52.0	20.4
6	3462.20	Hor.	-	-	13.20	10.07	-	-	-	-
		Ver.	-	-	13.20	10.07	-	-	-	-
7	3956.80	Hor.	-	-	13.43	9.85	-	-	-	-
		Ver.	-	-	13.43	9.85	-	-	-	-
8	4451.40	Hor.	-	-	13.63	11.18	-	-	-	-
		Ver.	-	-	13.63	11.18	-	-	-	-
9	4946.00	Hor.	-	-	13.84	11.25	-	-	-	-
		Ver.	-	-	13.84	11.25	-	-	-	-

There is the margin of 20dB over except for the above points.

$$\text{Mask E Limit (dBc)} = -(55+10\text{Log}(P))$$

$$\text{Correct Level (dBm)} = \text{Substitute SG Level (dBm)} + \text{ANT Gain (dBi)} - \text{Loss (Cable, Attenuator) (dB)}$$

$$\text{Emission Level (dBc)} = \text{Correct Level (dBm)} - 10\text{Log}(P*1000)$$

$$P = \text{Carrier Level (W)}$$

" - " = Measurement Limit

5.4 Emission Masks (Occupied Bandwidth)

REGULATIONS	: 47 CFR 2.1049 (c) (1), 22.359, 357 (a) (1) , 74.1236 , 90.210
TEST METHOD/GUIDE	: ANSI/TIA-603-C Section 2.2.11.2

Test Procedure

- 1 The EUT and test equipment were set up as shown on the following page.
- 2 For EUT supporting audio modulation, the audio signal generator was adjusted to the frequency of maximum response and with output level set for +/- 2.5 kHz or +/- 1.25 kHz deviation (or 50 % modulation).
- 3 With level constant, the signal level was increased 16 dB.
 For EUT supporting digital modulation, the digital modulation mode was operated to its maximum extent.
- 4 Adjust the spectrum analyzer for the following setting:
 - a) RBW : 100 Hz (Non modulation and Authorized Band 11.25 kHz), 300Hz (Authorized Band 20 kHz).
 - b) VBW : 100Hz (Non modulation and Authorized Band 11.25 kHz), 300 Hz (Authorized Band 20 kHz).
 - c) RBW and VBW : 30 kHz (Non Modulation of Authorized Band 6 kHz).
 - d) Sweep Speed : 8 sec.
 - e) Sampling Time : 10 times
- 5 The occupied Bandwidth was measured with the Spectrum Analyzer controls set as shown on the test results.

Measuring Equipments

No.	Equipment	Manufacture	Model No.	Serial No.	Cal Date	Cal Exp.
1	Audio Generator	Anritsu	MG443B	M70150	Jul. 24, 07	Jul. 31, 08
2	Attenuator (30dB)	Weinschel	WA-29-30-34	8923	Jun. 19, 07	Jun. 30, 08
4	Modulation Analyzer	Hewlett Packard	8901B	2806A01669	Mar. 21, 07	Mar. 31, 08
5	Spectrum Analyzer	Agilent	E4407B	MY45102460	Jan. 09, 08	Jan. 31, 09
6	DC Power Supply	Daiwa	PS-3020	None	None	None
7	Digital Multi Meter	Sanwa	CD721	3215593	May 18, 07	May 31, 08

Measuring Cables

No.	Cable	Manufacture	Model No.	Serial No.	Cal Date	Cal Exp.
W1	Coaxial Cable	Suhner	SUCOFLEX102	KSR00091	Mar. 22, 07	Mar. 31, 08
W2	Coaxial Cable	Pacific custom	RG-58 C/U	AM90C03	Aug. 31, 07	Aug. 31, 08
W4	Coaxial Cable	Pacific custom	RG-58 C/U	KSR00041	Aug. 30, 07	Aug. 31, 08
W5	Balance Cable	Nicoon	3D-2V	KSR00092	Oct. 16, 07	Oct. 31, 08

Measuring Equipment Configuration

<FM Modulation Case>

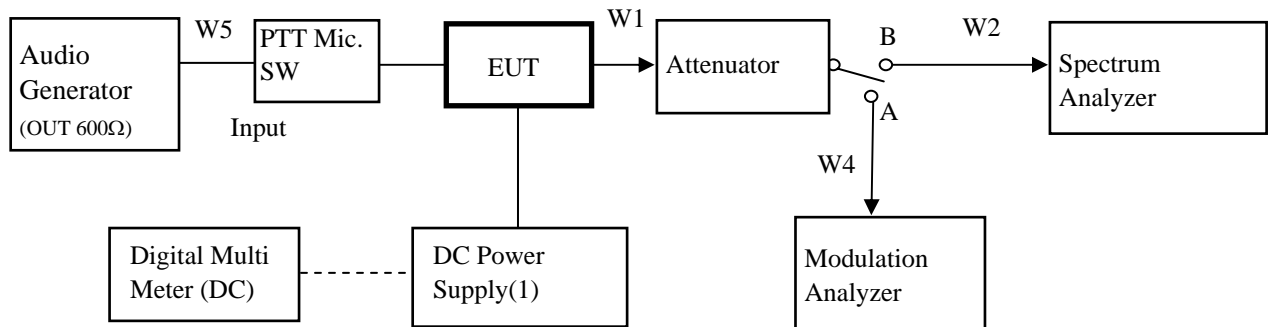

Note: Configuration of other Modulation test is composed without the Audio Generator.

Uncertainty

Measurement uncertainty is $\pm 1.0\text{dB}$ ($k = 2$)

Test Results

Test carried out for all the frequency band of section 5.1
Measured for the worst case

State : High Power / Authorized Bandwidth 20 kHz:FM / 477.1 MHz

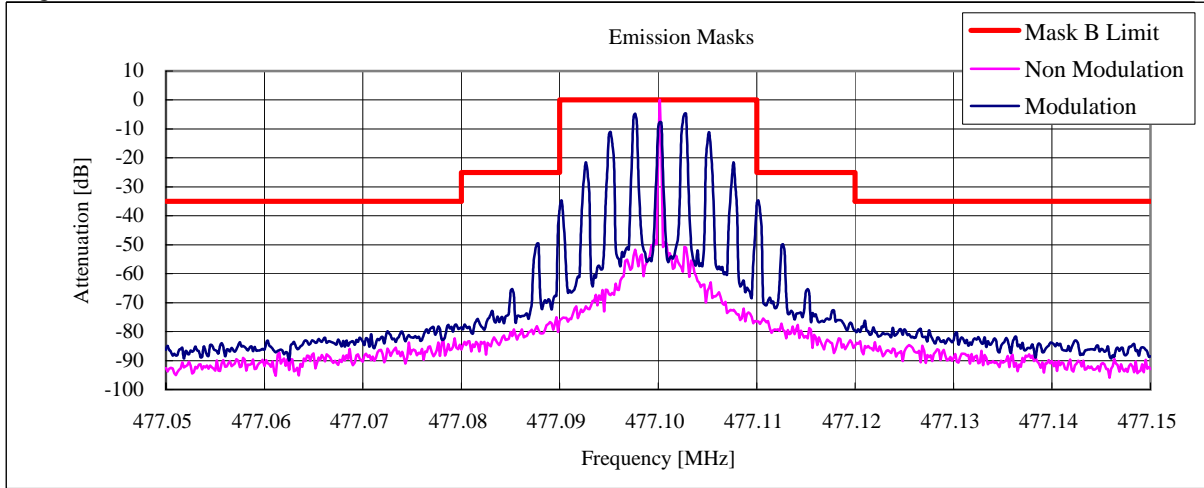

State : High Power / Authorized Bandwidth 11.25 kHz:FM / 477.1 MHz

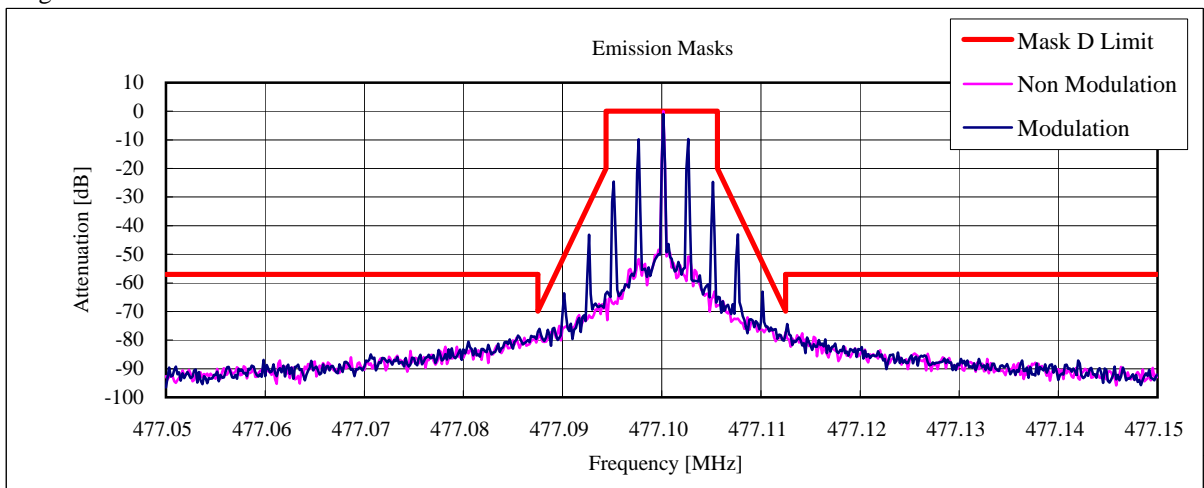

State : High Power / Authorized Bandwidth 11.25 kHz:4 Level FSK / 511.9 MHz

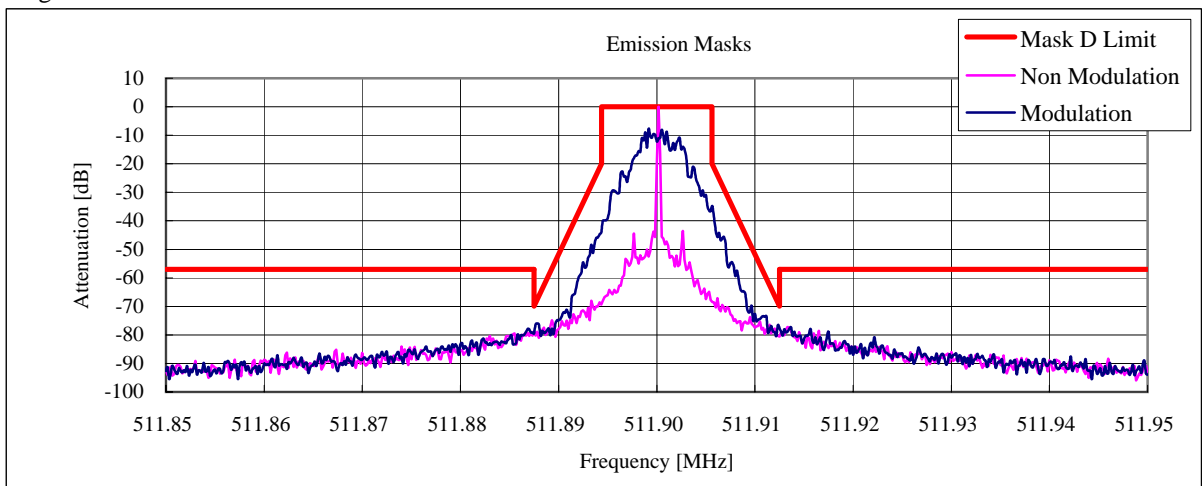

State : High Power / Authorized Bandwidth 6 kHz:4Level FSK / 511.9 MHz

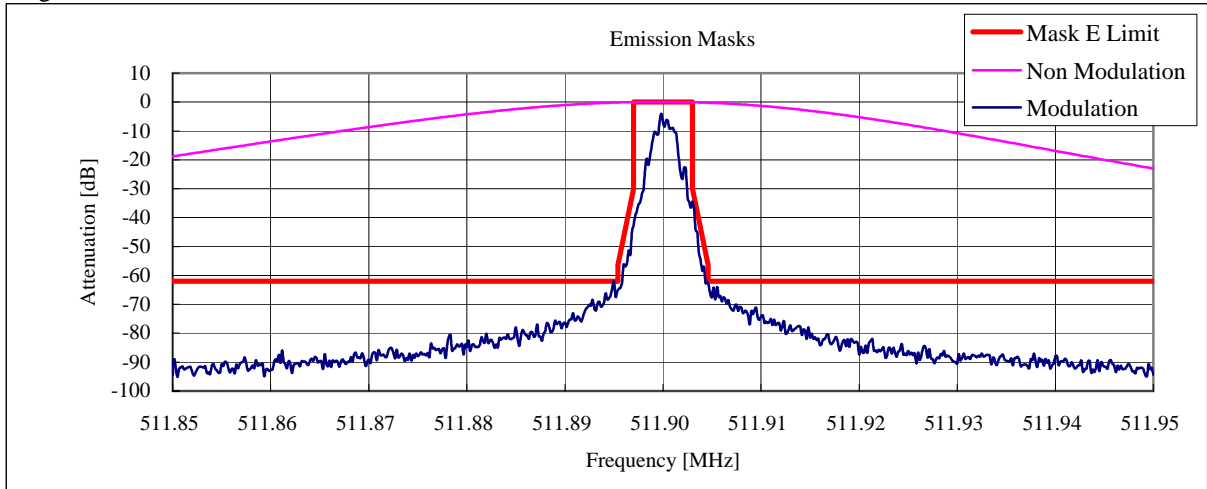

State : High Power / Authorized Bandwidth 6 kHz:CWID / 511.9 MHz

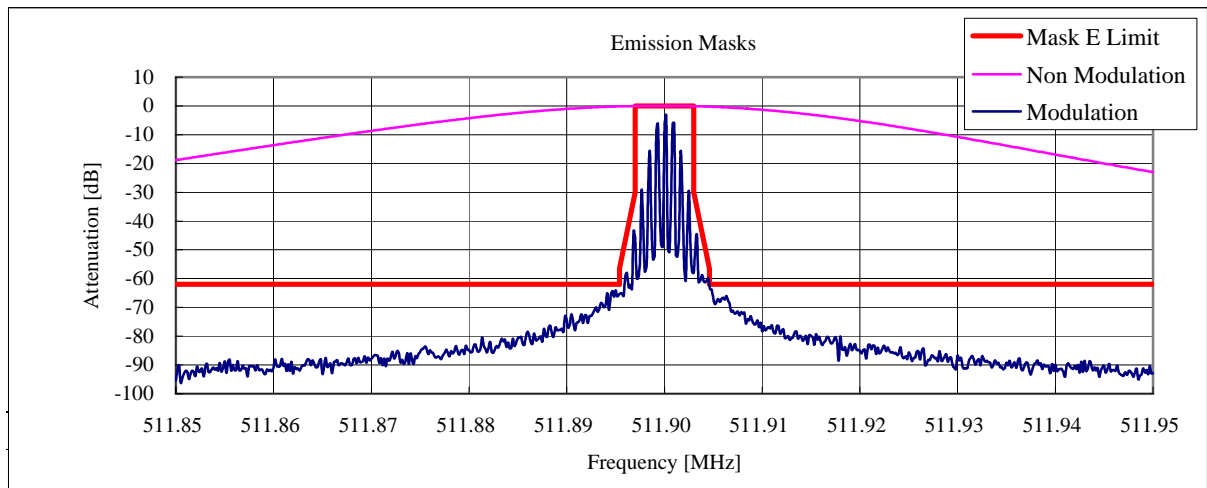

State : Low Power / Authorized Bandwidth 20 kHz:FM / 477.1 MHz

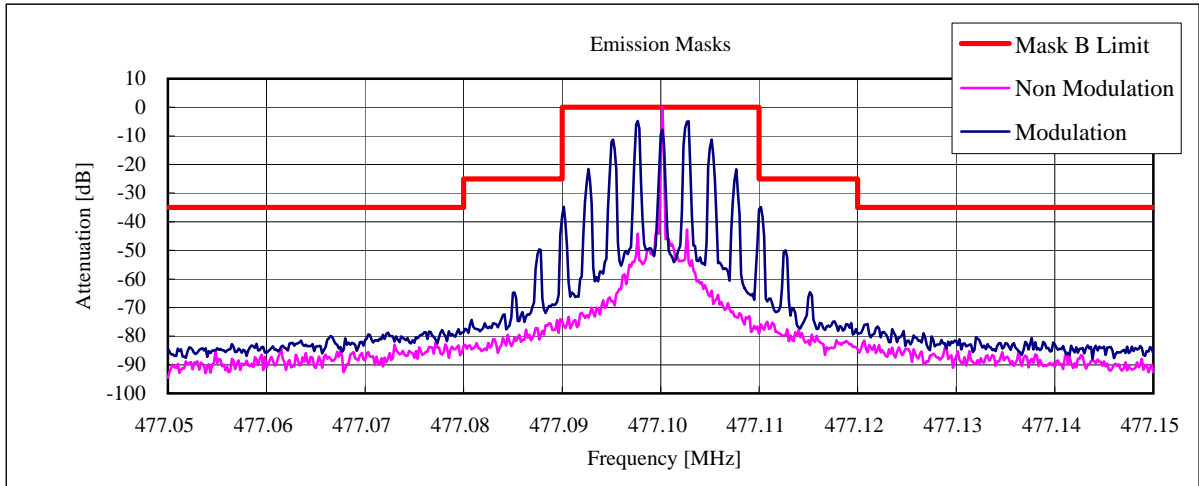

State : Low Power / Authorized Bandwidth 11.25 kHz:FM / 477.1 MHz

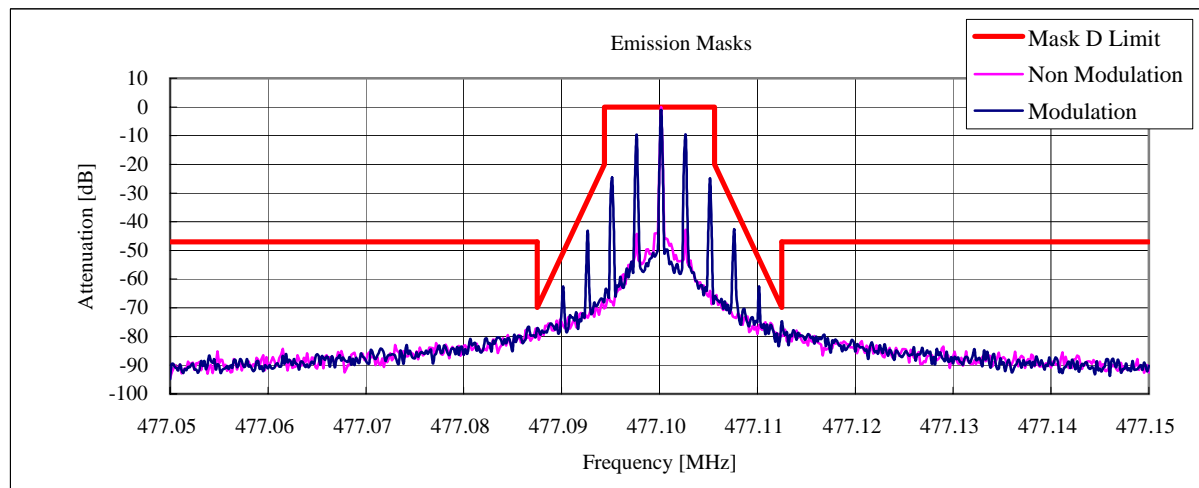

State : Low Power / Authorized Bandwidth 11.25 kHz:4 Level FSK / 511.9 MHz

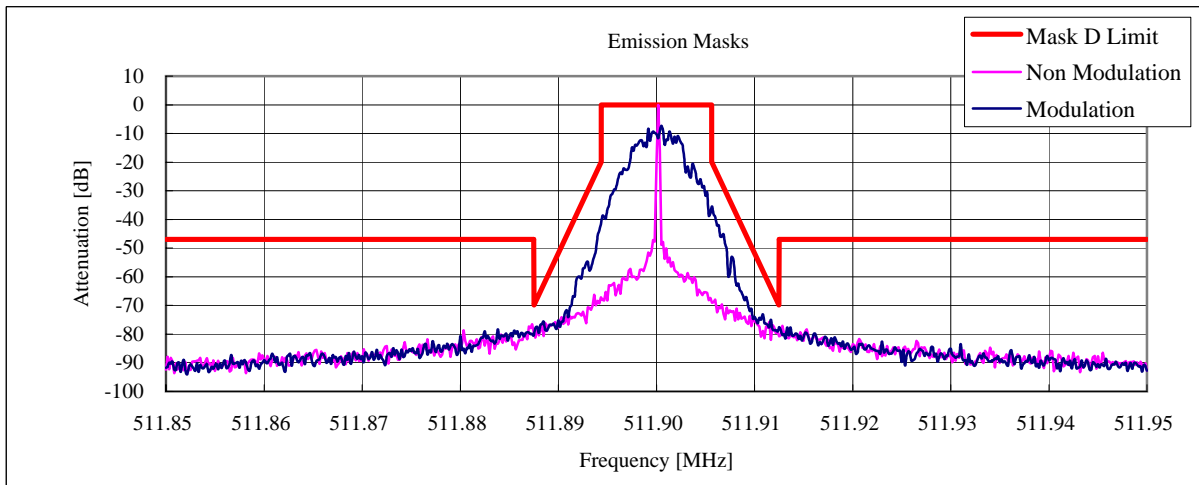

State : Low Power / Authorized Bandwidth 6 kHz:4Level FSK / 511.9 MHz

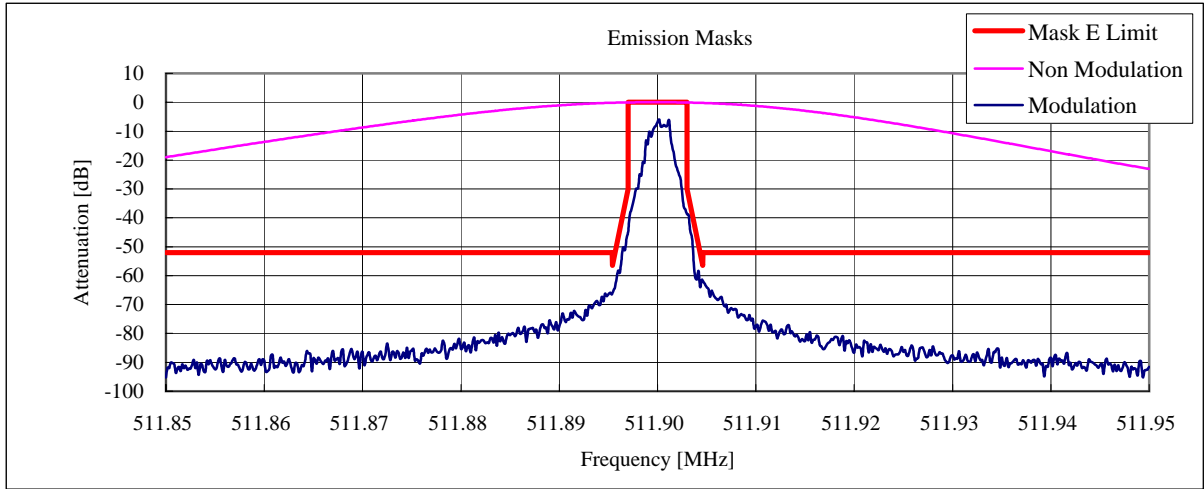

State : Low Power / Authorized Bandwidth 6 kHz:CWID / 511.9 MHz

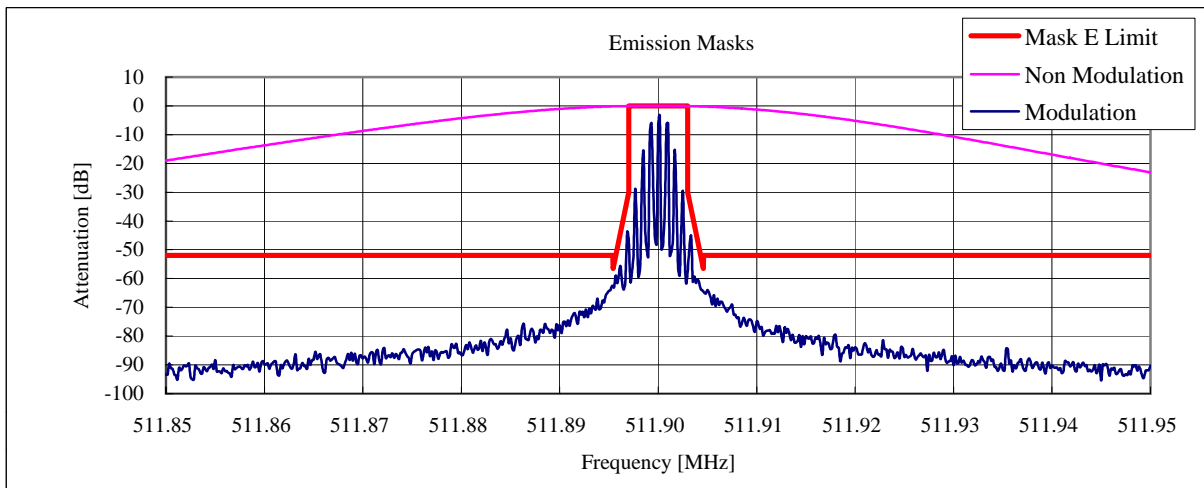

5.5 Transient Frequency Behavior

REGULATIONS	: 47 CFR 90.214
TEST METHOD/GUIDE	: ANSI/TIA-603-C Section 2.2.19.3

Test Procedure

- 1 The EUT and test equipment were set up as shown on the following page.
- 2 The transmitter was turned on.
- 3 Sufficient attenuation was provided so that the transmitter carrier level measured at the output of the combiner was 40 dB below the maximum input level of the test receiver.
This level was recorded as step f.
- 4 The transmitter was turned off.
- 5 An RF signal generator (1) modulated with a 1 kHz tone at either 25 kHz or 12.5 kHz or 6.25 kHz deviation, and set to the same frequency as the assigned transmitter frequency, (2) was adjusted to a level -20 dB below the level recorded for step f, as measured at the output of the combiner.
This level was then fixed for the remainder of the test and is recorded at step h.
- 6 The oscilloscope was setup using TIA-603C steps j and k as a guide, and to 10 msec./div.
- 7 The transmitter was turned on, and the level of the carrier at the output of the combiner was recorded as step l.
- 8 The carrier on-time as referenced in TIA-603-C steps m, n, and o was captured and plotted.
- 9 The carrier off-time as referenced in TIA-603-C steps p, q, r, and s was captured and plotted.

Measuring Equipments

No.	Equipment	Manufacture	Model No.	Serial No.	Cal Date	Cal Exp.
1	Signal Generator	Rohde & Schwarz	SMG	860289/011	Jul. 09, 07	Jul. 31, 08
2	Oscilloscope	Tektronix	TDS 680B	B010292	Sep. 11, 07	Sep. 30, 08
3	Power Meter	Hewlett Packard	E4418B	GB38410265	May. 17, 07	May. 31, 08
4	Power Sensor	Hewlett Packard	8482A	US37292237	May 09, 07	May. 31, 08
5	Attenuator (30dB)	Weinschel	WA-29-30-34	8923	Jun. 19, 07	Jun. 30, 08
6	Modulation Analyzer	Hewlett Packard	8901B	2806A01669	Mar. 21, 07	Mar. 31, 08
7	Combiner(1)	Anritsu	Z-164A	M89549	Aug. 16, 07	Aug. 31, 08
8	Combiner(2)	Anritsu	Z-164A	M89249	Aug. 16, 07	Aug. 31, 08
9	Attenuator	TME	CFA-20NPJ-3	679701	Aug. 16, 07	Aug. 31, 08
10	DC Power Supply	Daiwa	PS-3020	None	None	None
11	Digital Multi Meter	Sanwa	CD721	3215593	May 18, 07	May 31, 08

Measuring Cables

No.	Cable	Manufacture	Model No.	Serial No.	Cal Date	Cal Exp.
W1	Coaxial Cable	Suhner	SUCOFLEX102	KSR00091	Mar. 22, 07	Mar. 31, 08
W2	Coaxial Cable	Pacific custom	RG-58 C/U	AM90C03	Aug. 31, 07	Aug. 31, 08
W4	Coaxial Cable	Pacific custom	RG-58 C/U	KSR00093	Aug. 31, 07	Aug. 31, 08
W5	Coaxial Cable	Pacific custom	RG-58 C/U	KSR00041	Aug. 30, 07	Aug. 31, 08
W6	Coaxial Cable	Pacific custom	RG-58 C/U	KSR00094	Aug. 30, 07	Aug. 31, 08
W7	Coaxial Cable	JOIN	3D-2V	KSR00101	Aug. 30, 07	Aug. 31, 08

Measuring Equipment Configuration

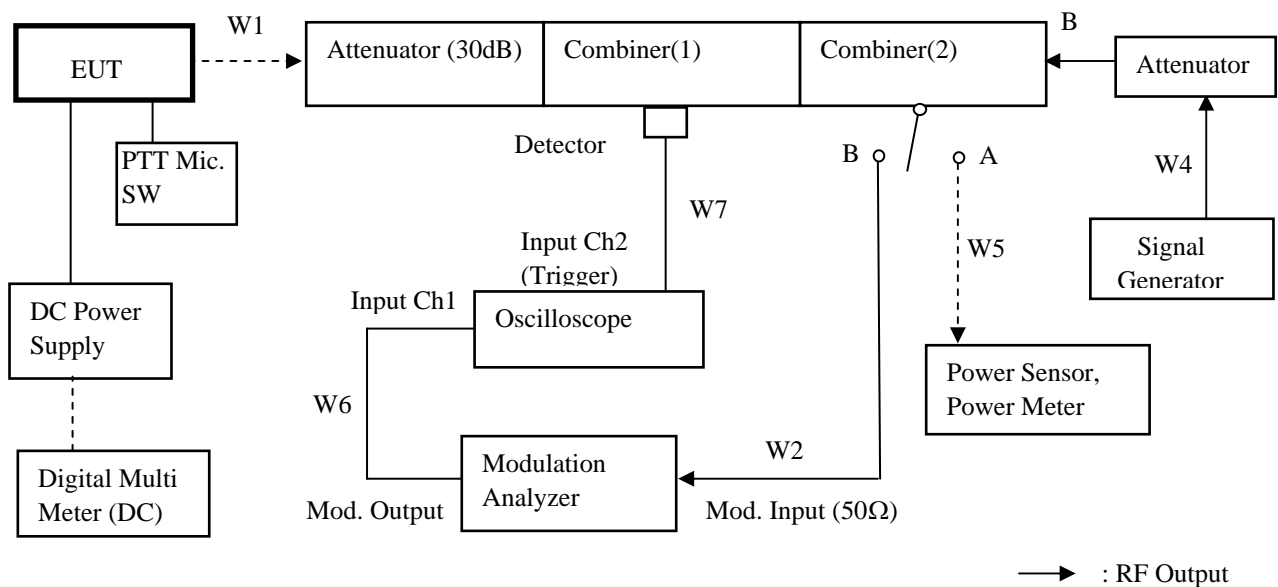

Uncertainty

Measurement uncertainty is +/- 1.1dB (k = 2)

Test Results

Test carried out for all the frequency band of section 5.1
Measured for the worst case

State : High Power / Authorized Bandwidth 20 kHz:FM / 494.6 MHz / PTT:OFF -ON

Tek Run: 5.00kS/s Sample **11192**

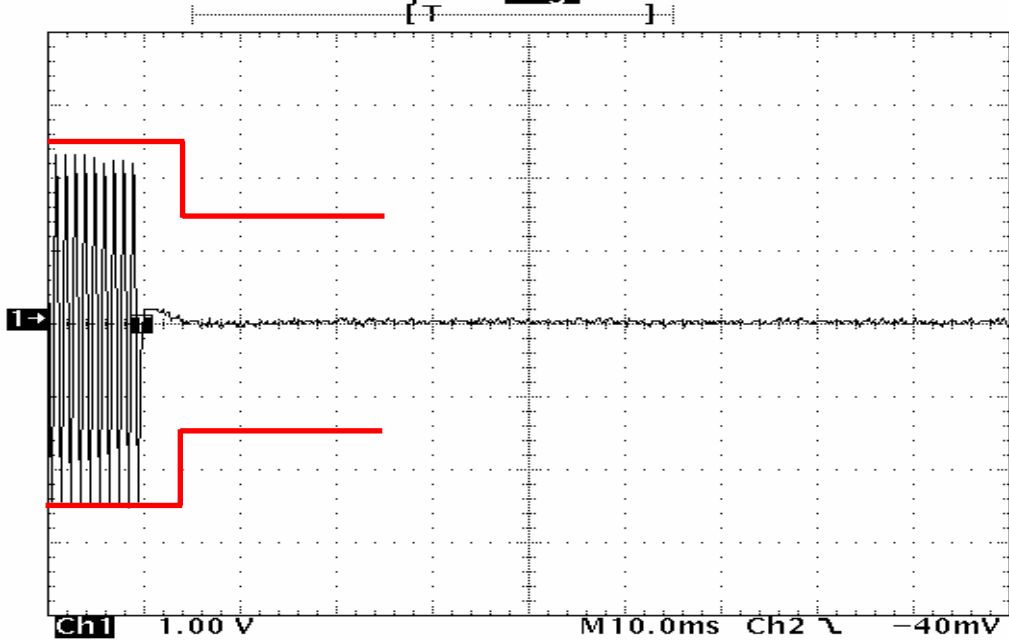

21 Feb 2008
10:00:27

State : High Power / Authorized Bandwidth 20 kHz:FM / 494.6 MHz / PTT:ON -OFF

Tek Run: 5.00kS/s Sample **11192**

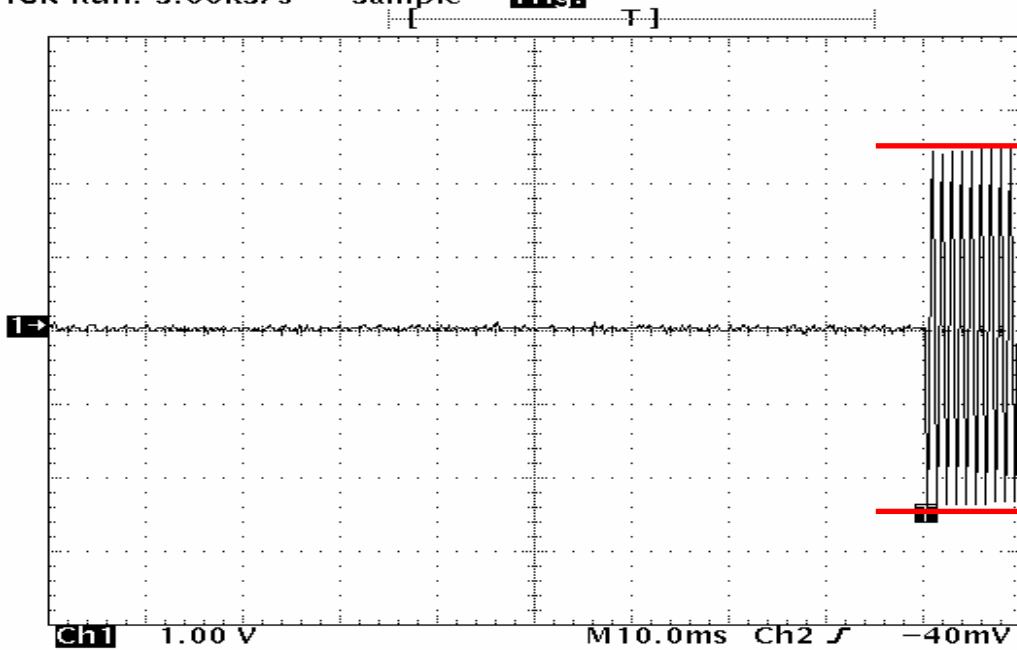

21 Feb 2008
10:06:42

State : High Power / Authorized Bandwidth 11.25 kHz:4Level FSK / 494.6 MHz / PTT:OFF -ON
Tek Run: 5.00kS/s Sample **TRIG**

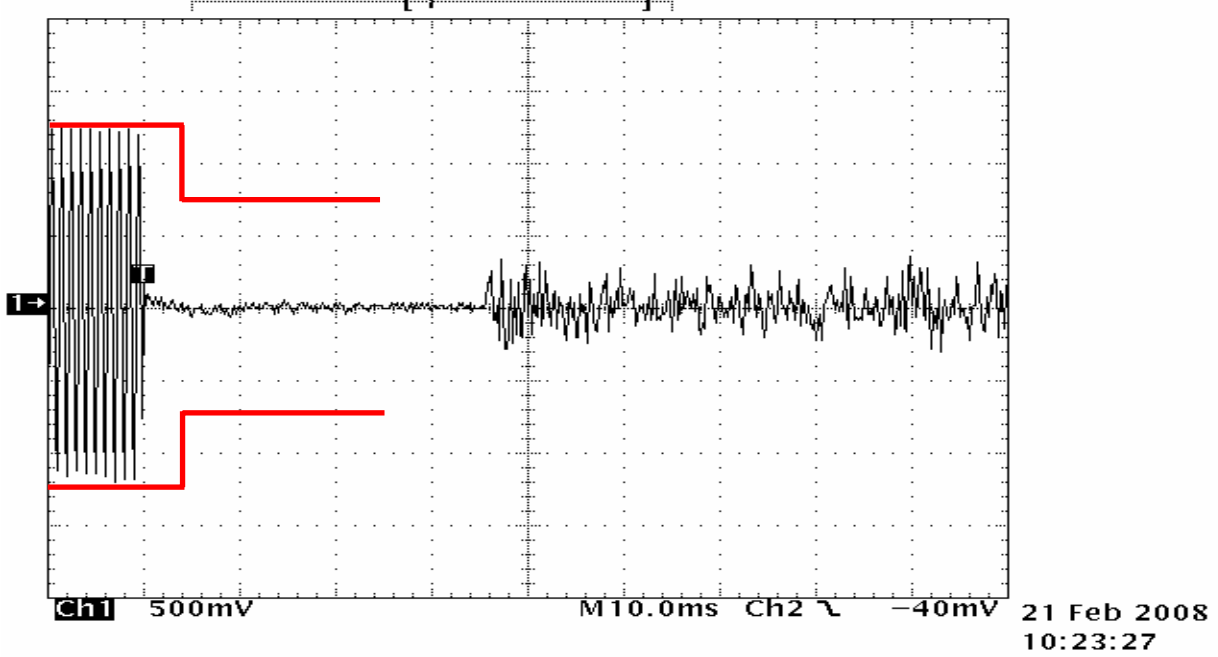

State : High Power / Authorized Bandwidth 11.25 kHz:4Level FSK / 494.6 MHz / PTT:ON -OFF
Tek Run: 5.00kS/s Sample **TRIG**

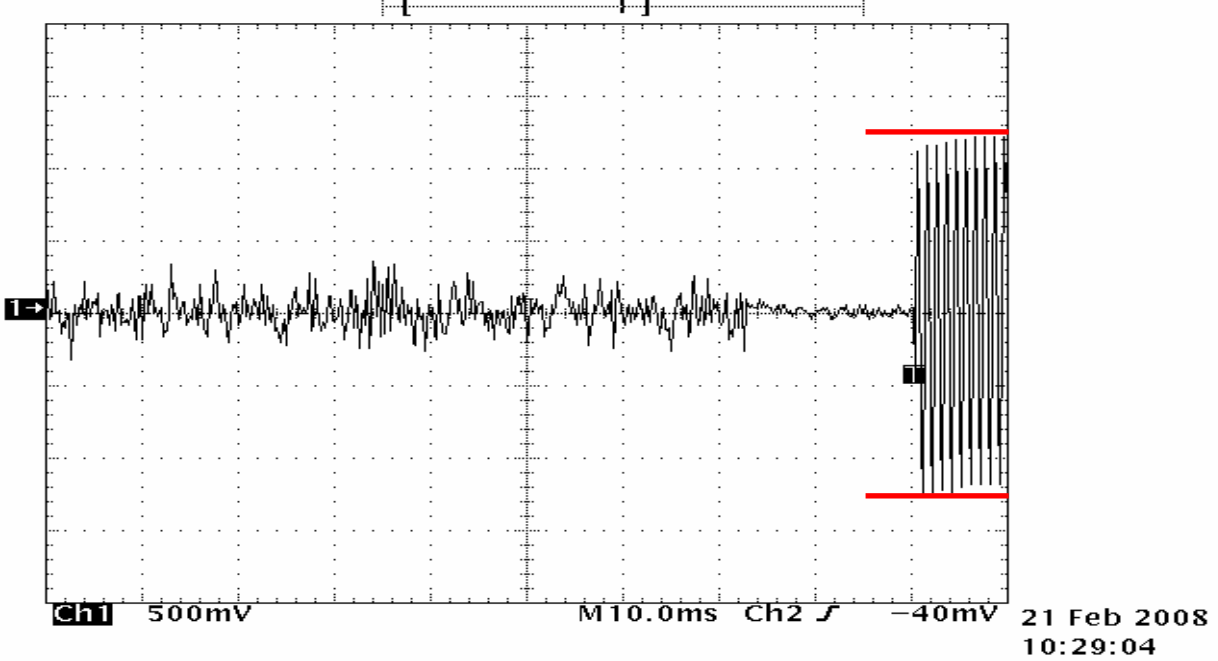

State : High Power / Authorized Bandwidth 6 kHz: CW ID / 494.6 MHz / PTT: OFF -ON

Tek Run: 5.00kS/s Sample **11192**

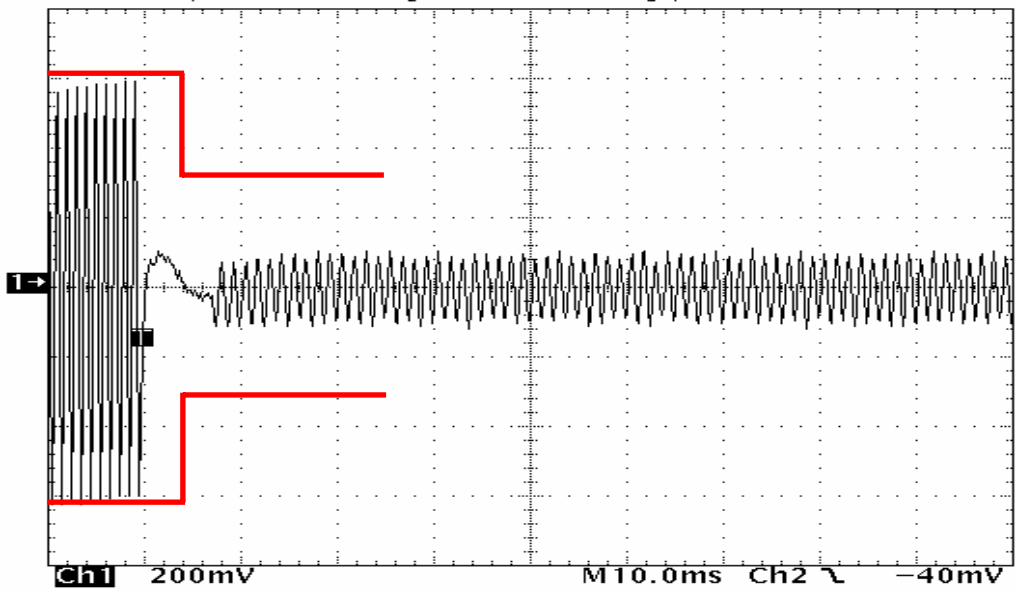

21 Feb 2008
10:53:49

State : High Power / Authorized Bandwidth 6 kHz: CW ID / 494.6 MHz / PTT: ON -OFF

Tek Run: 5.00kS/s Sample **11192**

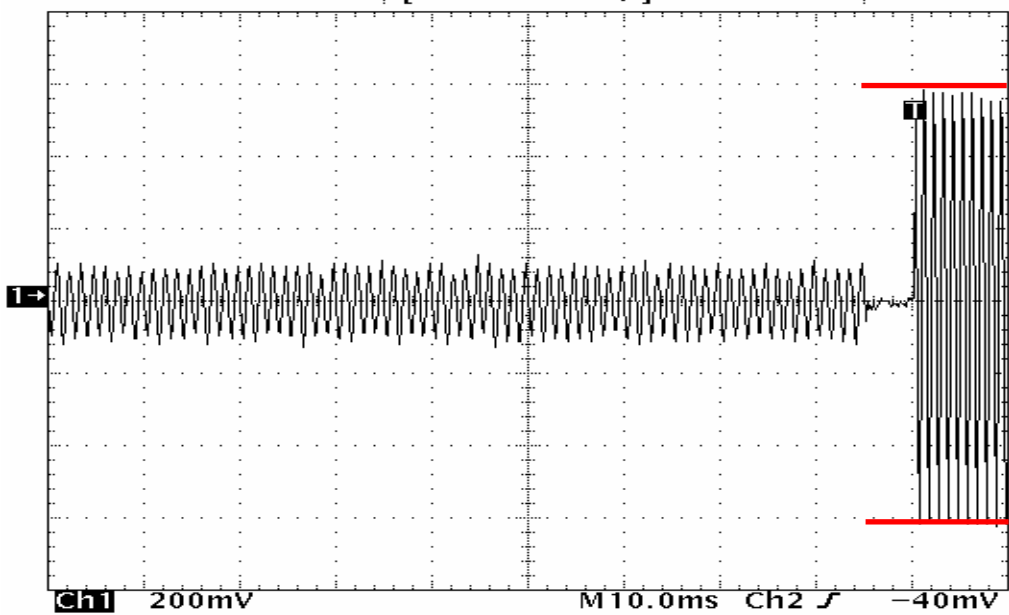

21 Feb 2008
10:59:08

5.6 Audio Frequency Response / Audio Low Pass Filter (Voice Input)

REGULATIONS	: 47 CFR 2.1047 (a)
TEST METHOD/GUIDE	: ANSI/TIA-603-C Section 2.2.6.2.2, 3.2.6.2

Test Procedure

- 1 The EUT and test equipment were set up as shown on the following page.
- 2 Adjust the Modulation Analyzer for the following setting:
 - a) High-pass filter : 50 Hz
 - b) Low-pass filter : 15 kHz
 - c) Detector : positive peak
 - d) Function : FM
- 3 The audio signal input was adjusted to obtain 20 % modulation at 1 kHz, and this point was taken as the 0 dB reference level.
- 4 With input levels held constant and below limiting at all frequencies, the audio signal generator was varied from 300 Hz to 20 kHz (Authorized Bandwidth 11.25 kHz) or 30 kHz (Authorized Bandwidth 20 kHz).
- 5 The response in dB relative to 1 kHz was then measured, using the Modulation Analyzer.

Measuring Equipments

No.	Equipment	Manufacture	Model No.	Serial No.	Cal Date	Cal Exp.
1	Audio Generator	Anritsu	MG443B	M70150	Jul. 24, 07	Jul. 31, 08
2	Audio Analyzer	Hewlett Packard	8903B	2948A07326	Apr. 25, 07	Apr. 30, 08
3	Attenuator (30dB)	Weinschel	WA-29-30-34	8923	Jun. 19, 07	Jun. 30, 08
4	Modulation Analyzer	Hewlett packard	8901B	2806A01669	Mar. 21, 07	Mar. 31, 08
5	DC Power Supply	Daiwa	PS-3020	None	None	None
6	Digital Multi Meter	Sanwa	CD721	3215593	May. 18, 07	May. 31, 08

Measuring Cables

No.	Cable	Manufacture	Model No.	Serial No.	Cal Date	Cal Exp.
W1	Coaxial Cable	Suhner	SUCOFLEX102	KSR00091	Mar. 22, 07	Mar. 31, 08
W2	Coaxial Cable	Pacific custom	RG-58 C/U	AM90C03	Aug. 31, 07	Aug. 31, 08
W5	Balance Cable	Nicoon	3D-2V	KSR00092	Oct. 16, 07	Oct. 31, 08
W6	Coaxial Cable	Pacific custom	RG-58 C/U	KSR00094	Aug. 30, 07	Aug. 31, 08

Measuring Equipment Configuration

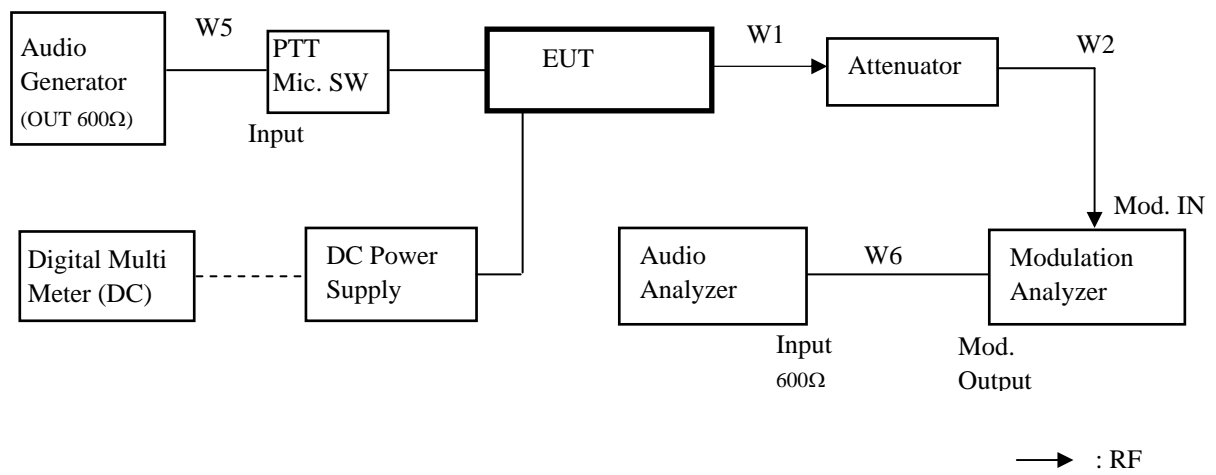

Uncertainty

Measurement uncertainty is +/- 0.3dB (k = 2)

Test Results

Test carried out for all the frequency band of section 5.1
Measured for the worst case

State : High Power / Authorized Bandwidth 20 kHz / 494.6 MHz

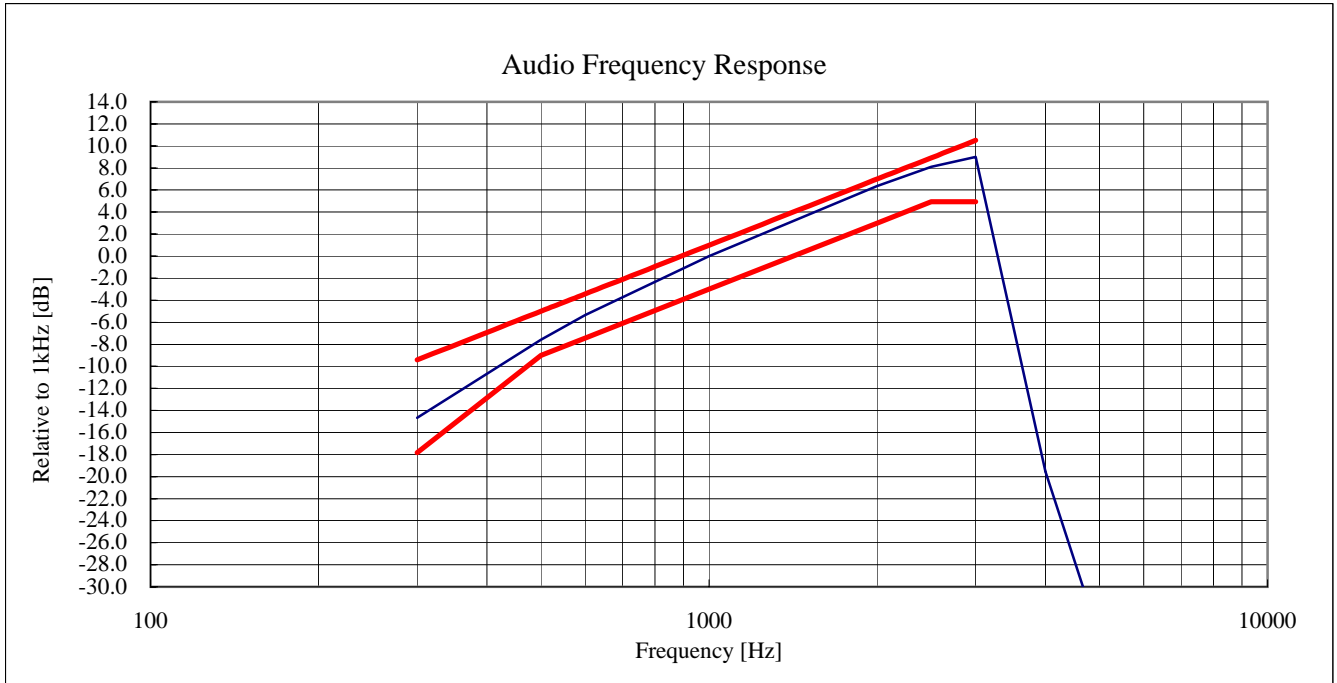

State : High Power / Authorized Bandwidth 11.25 kHz / 494.6 MHz

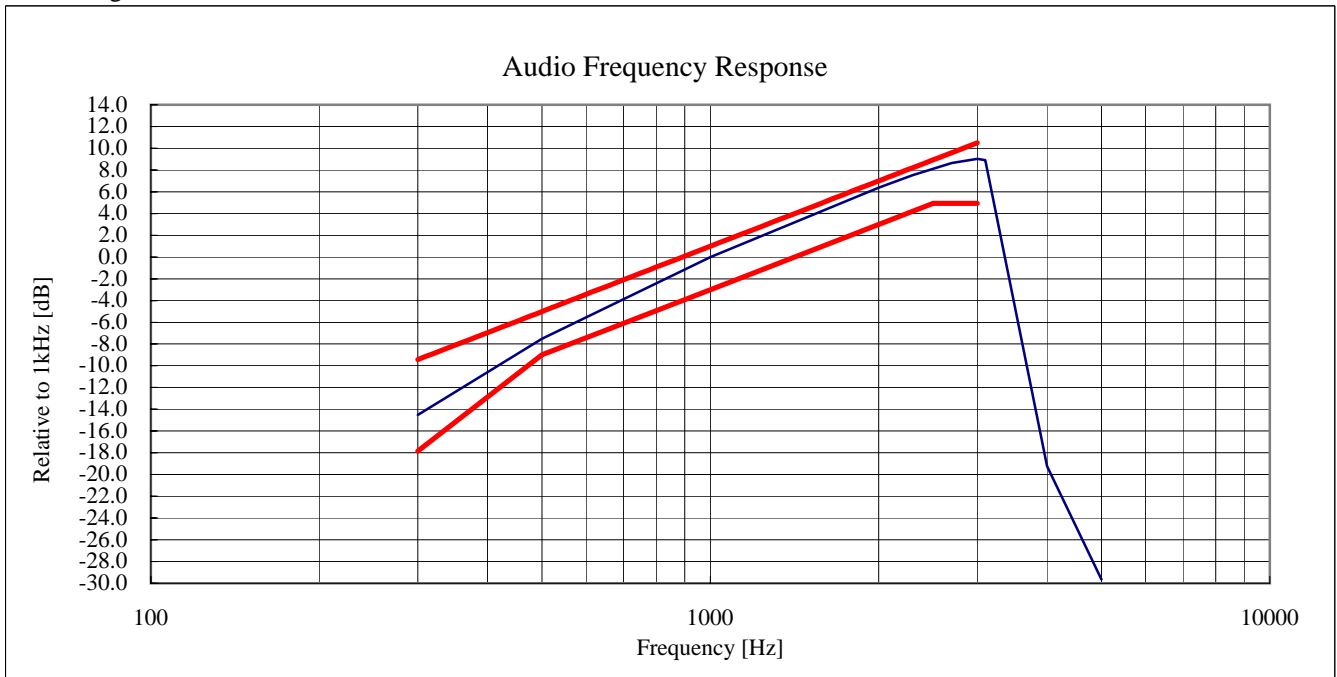

Note:

Audio Filter of the above result is substituted with the same structure as Audio Frequency Resonse.

On the transmission condition below 3kHz, Transceiver shows pre-emphasis condition of transmission function.

On the transmission condition above 3kHz, Transceiver shows Audio Low Pass Filter.

5.7 Modulation Limiting

REGULATIONS	: 47 CFR 2.1047 (b)
TEST METHOD/GUIDE	: ANSI/TIA-603-C Section 2.2.3.2, 1.3.4.4

Test Procedure

- 1 The EUT and test equipment were set up as shown on the following page.
- 2 Adjust the Modulation Analyzer for the following setting:
 - a) High-pass filter : off
 - b) Low-pass filter : 15 kHz
 - c) Detector : positive peak
 - d) Function : FM
- 3 Apply a 1kHz modulation signal to the transmitter from the audio generator, and adjust the level to obtain 60% of full rated system deviation.
- 4 Measure the modulation frequency that was showed on the Modulation Analyzer when the output levels of the Audio Generator were changed from -20 dB to +50 dB by 10 dB.
- 5 Set the output frequencies of the Audio Generator 300 Hz and 3 kHz, and repeat test procedure 4.
- 6 Set the the Detector of the Modulation Analyzer Negative Peak.
- 7 Repeat test procedure 4 and 5.

Measuring Equipments

No.	Equipment	Manufacture	Model No.	Serial No.	Cal Date	Cal Exp.
1	Audio Generator	Anritsu	MG443B	M70150	Jul. 24, 07	Jul. 31, 08
2	Attenuator (30dB)	Weinschel	WA-29-30-34	8923	Jun. 19, 07	Jun. 30, 08
3	Modulation Analyzer	Hewlett packard	8901B	2806A01669	Mar. 21, 07	Mar. 31, 08
4	DC Power Supply	Daiwa	PS-3020	None	None	None
5	Digital Multi Meter	Sanwa	CD721	3215593	May. 18, 07	May. 31, 08

Measuring Cables

No.	Cable	Manufacture	Model No.	Serial No.	Cal Date	Cal Exp.
W1	Coaxial Cable	Suhner	SUCOFLEX102	KSR00091	Mar. 22, 07	Mar. 31, 08
W2	Coaxial Cable	Pacific custom	RG-58 C/U	AM90C03	Aug. 31, 07	Aug. 31, 08
W5	Balance Cable	Nicoon	3D-2V	KSR00092	Oct. 16, 07	Oct. 31, 08

Measuring Equipment Configuration

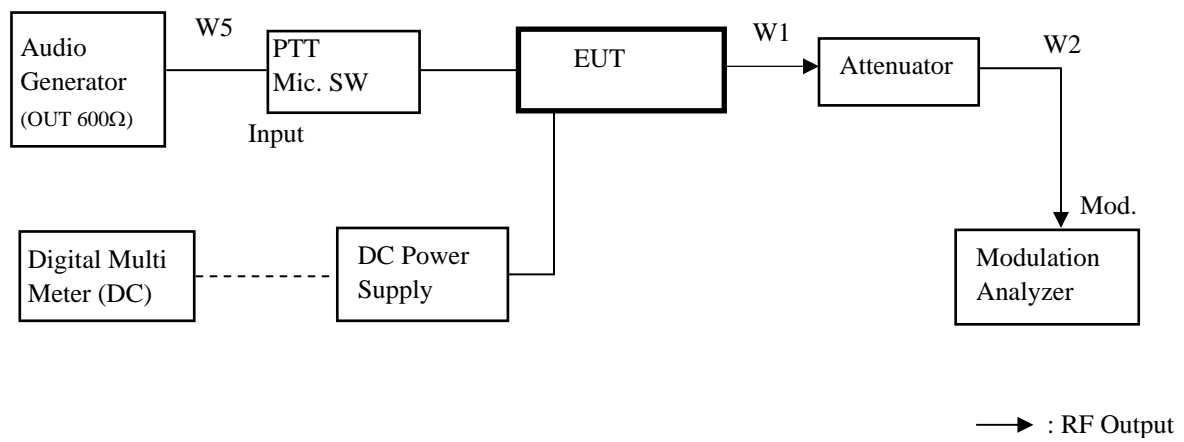

Uncertainty

Measurement uncertainty is +/- 0.3dB (k = 2)

Test Results

Test carried out for all the frequency band of section 5.1
Measured for the worst case

State : High Power / Authorized Bandwidth 20 kHz / 494.6 MHz

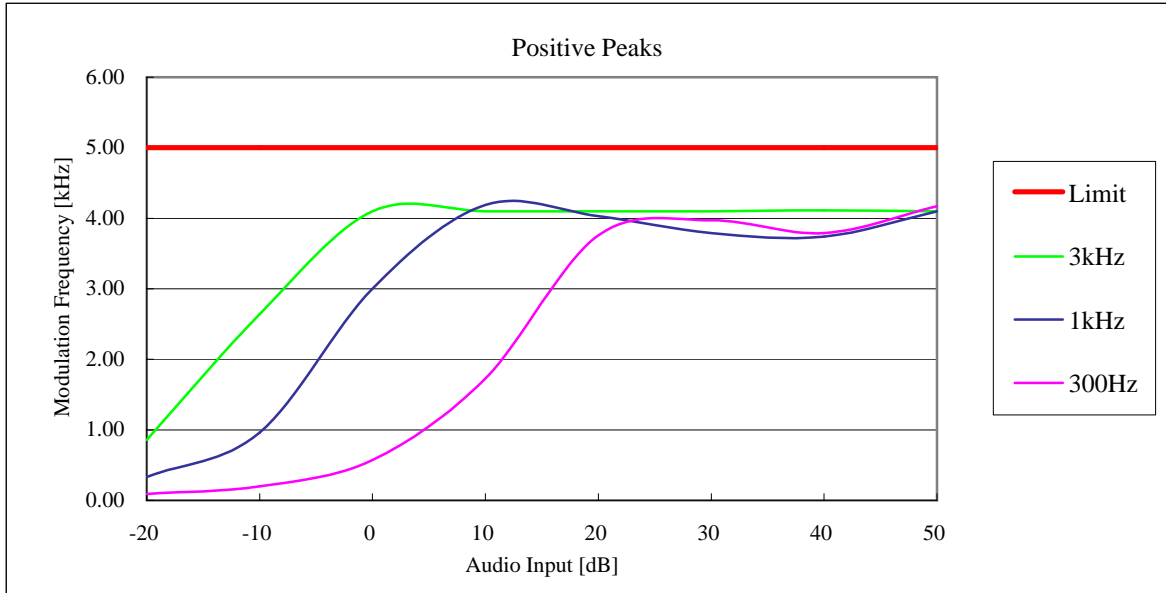

State : High Power / Authorized Bandwidth 20 kHz / 494.6 MHz

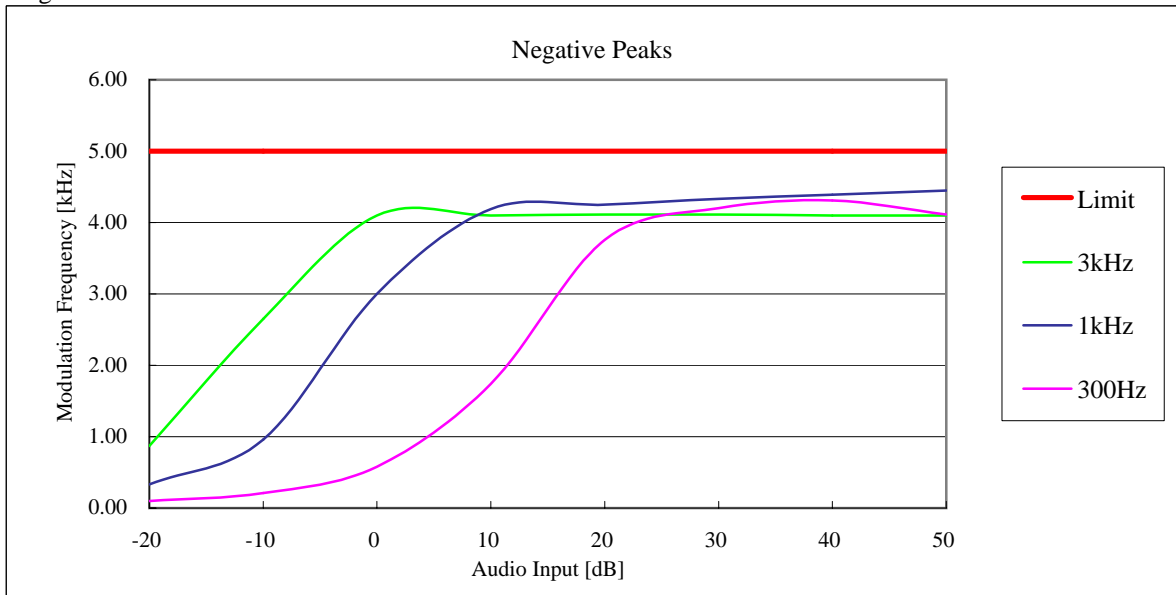

State : High Power / Authorized Bandwidth 11.25 kHz / 494.6 MHz

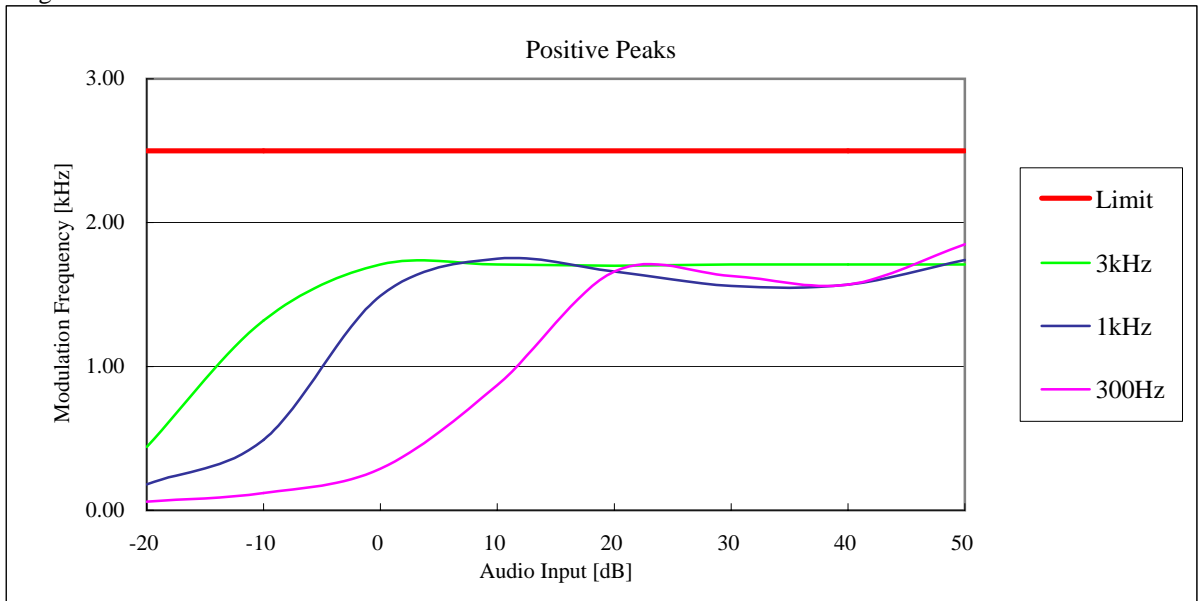

State : High Power / Authorized Bandwidth 11.25 kHz / 494.6 MHz

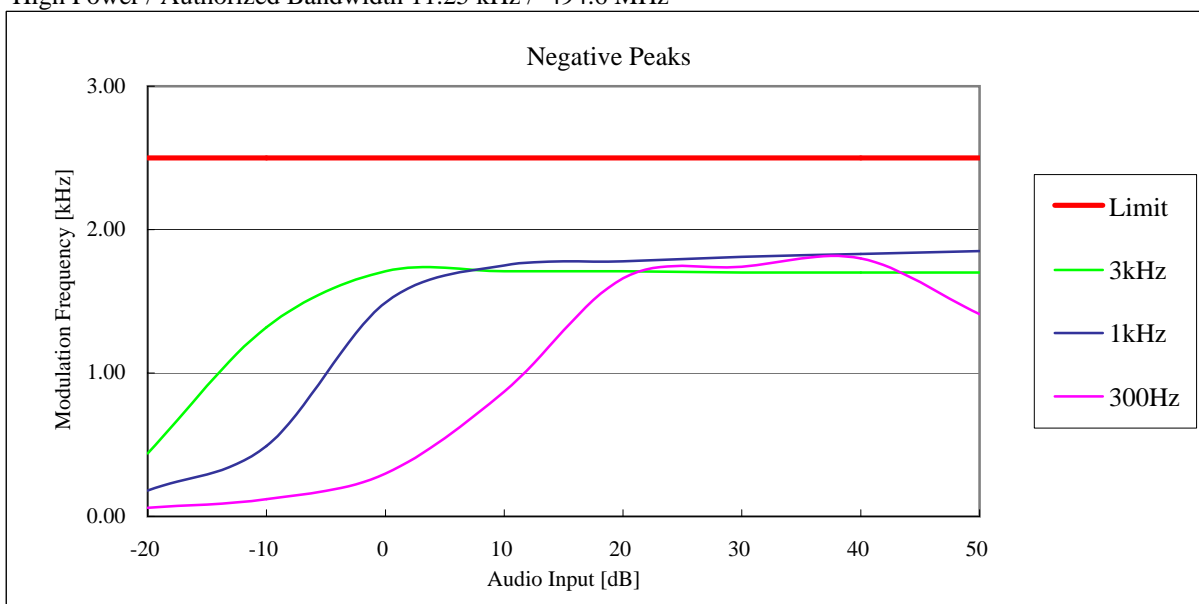

5.8 Frequency Stability (Temperature Variation)

REGULATIONS	: 47 CFR 2.1055 (a) (1), 22.355 , 74.1261 (b) , 90.213(a)
TEST METHOD/GUIDE	: ANSI/TIA-603-C Section 2.2.2.2

Test Procedure

- 1 The EUT and test equipment were set up as shown on the following page.
- 2 Set the temperature -30 degrees C.
- 3 Leave the EUT for 1 hour after it became the temperature that was set up.
- 4 Make the EUT the transmitting state.
Two minutes later, measure the output frequency.
- 5 Make the EUT the receiving state.
- 6 Set the temperature 50 degrees C by 10 degrees C.
And repeat test procedure 3 to 5.

Measuring Equipments

No.	Equipment	Manufacture	Model No.	Serial No.	Cal Date	Cal Exp.
1	Spectrum Analyzer	Agilent	E4407B	MY45102460	Jan. 09, 08	Jan. 31, 09
2	Attenuator (30dB)	Weinschel	WA-29-30-34	8923	Jun. 19, 07	Jun. 30, 08
3	DC Power Supply	Daiwa	PS-3020	None	None	None
4	Digital Multimeter	Sanwa	CD721	3215593	May 18, 07	May 31, 08
5	Temperature Chamber	Tabai	PL-3F	5103661	None	None
6	Temperature Meter	Sato	PC-5000TRH-II	A11999972	Mar. 22, 07	Mar. 31, 08

Measuring Cables

No.	Cable	Manufacture	Model No.	Serial No.	Cal Date	Cal Exp.
W1	Coaxial Cable	Suhner	SUCOFLEX102	KSR00091	Mar. 22, 07	Mar. 31, 08
W2	Coaxial Cable	Pacific custom	RG-58 C/U	AM90C03	Aug. 31, 07	Aug. 31, 08

Measuring Equipment Configuration

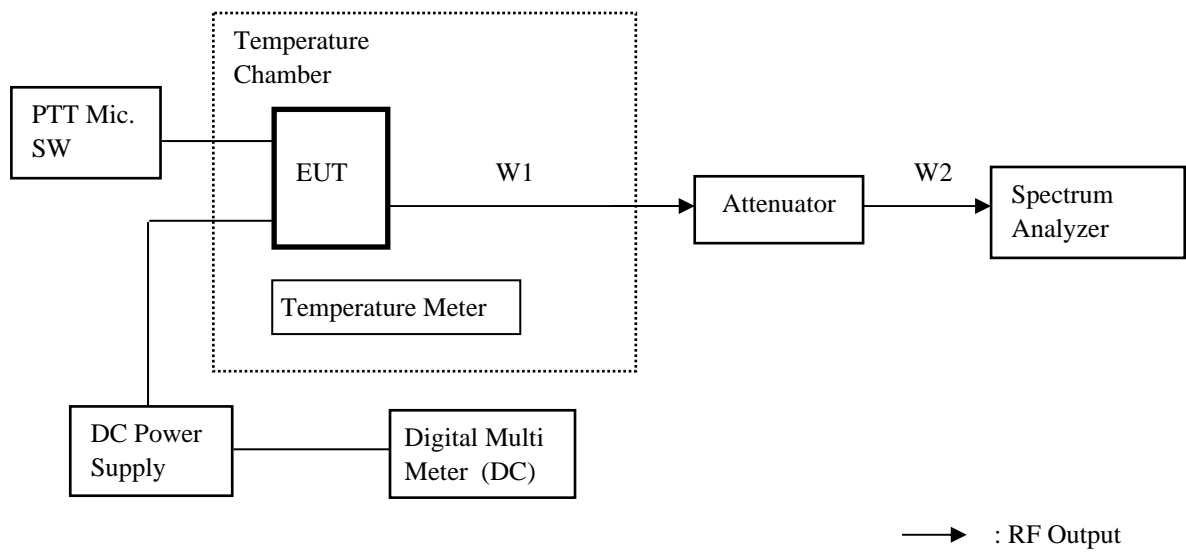

Uncertainty

Measurement uncertainty is +/- 0.2ppm

Test Results

Test carried out for all the frequency band of section 5.1
 Measured for the worst case

State : High Power / Authorized Bandwidth 6 kHz / 494.6 MHz

No.	Temperature (Degree C)	Frequency (MHz)	CFR Stability (ppm)	Limit (ppm)	Min. Margin (ppm)
1	-30	494.599912	-0.18	0.5	0.32
2	-20	494.599962	-0.08	0.5	0.42
3	-10	494.599987	-0.03	0.5	0.47
4	0	494.600012	0.02	0.5	0.48
5	10	494.600050	0.10	0.5	0.40
6	20	494.600025	0.05	0.5	0.45
7	30	494.600037	0.07	0.5	0.43
8	40	494.600062	0.13	0.5	0.37
9	50	494.600087	0.18	0.5	0.32

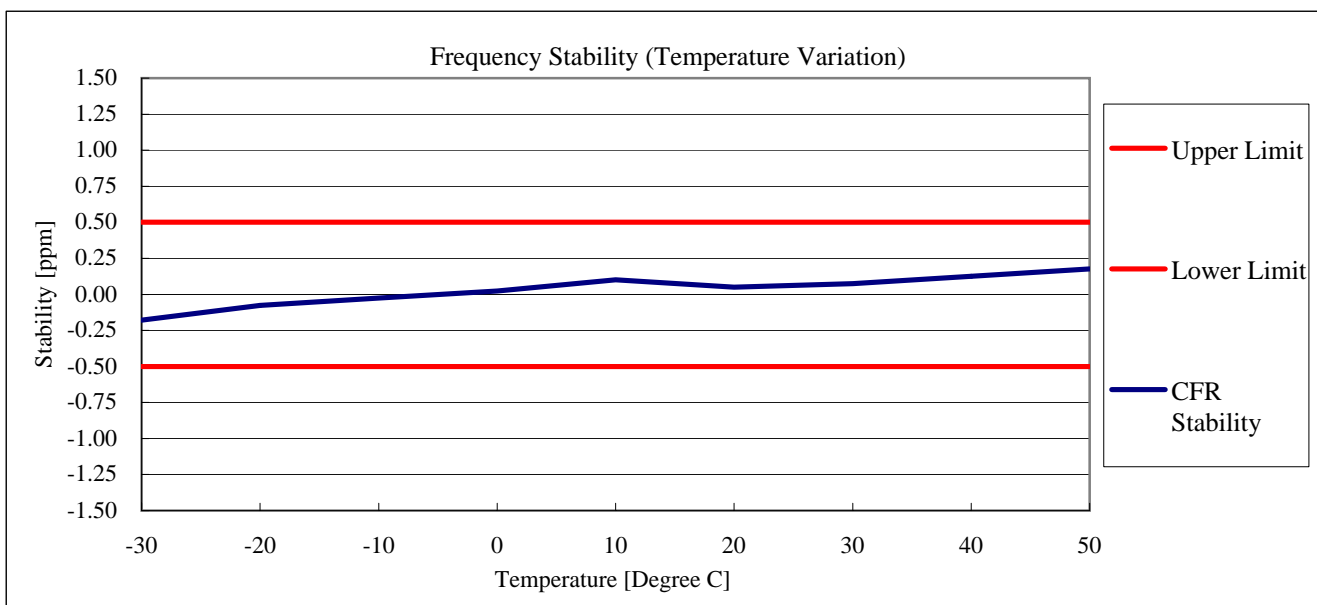

5.9 Frequency Stability (Voltage Variation)

REGULATIONS	: 47 CFR 2.1055 (d) (1), 22.355 , 74.1261 (b) , 90.213(a)
TEST METHOD/GUIDE	: ANSI/TIA-603-C Section 2.2.2.2

Test Procedure

- 1 The EUT and test equipment were set up as shown on the following page.
- 2 The power supply voltage to the EUT was varied from 85 % to 115 % of the nominal value measured at the input to the EUT.

Measuring Equipments

No.	Equipment	Manufacture	Model No.	Serial No.	Cal Date	Cal Exp.
1	Spectrum Analyzer	Agilent	E4407B	MY45102460	Jan. 09, 08	Jan. 31, 09
2	Attenuator (30dB)	Weinschel	WA-29-30-34	8923	Jun. 19, 07	Jun. 30, 08
3	DC Power Supply	Daiwa	PS-3020	None	None	None
4	Digital Multimeter	Sanwa	CD721	3215593	May 18, 07	May 31, 08
5	Temperature Chamber	Tabai	PL-3F	5103661	None	None
6	Temperature Meter	Sato	PC-5000TRH-II	A11999972	Mar. 22, 07	Mar. 31, 08

Measuring Cables

No.	Cable	Manufacture	Model No.	Serial No.	Cal Date	Cal Exp.
W1	Coaxial Cable	Suhner	SUCOFLEX102	KSR00091	Mar. 22, 07	Mar. 31, 08
W2	Coaxial Cable	Pacific custom	RG-58 C/U	AM90C03	Aug. 31, 07	Aug. 31, 08

Measuring Equipment Configuration

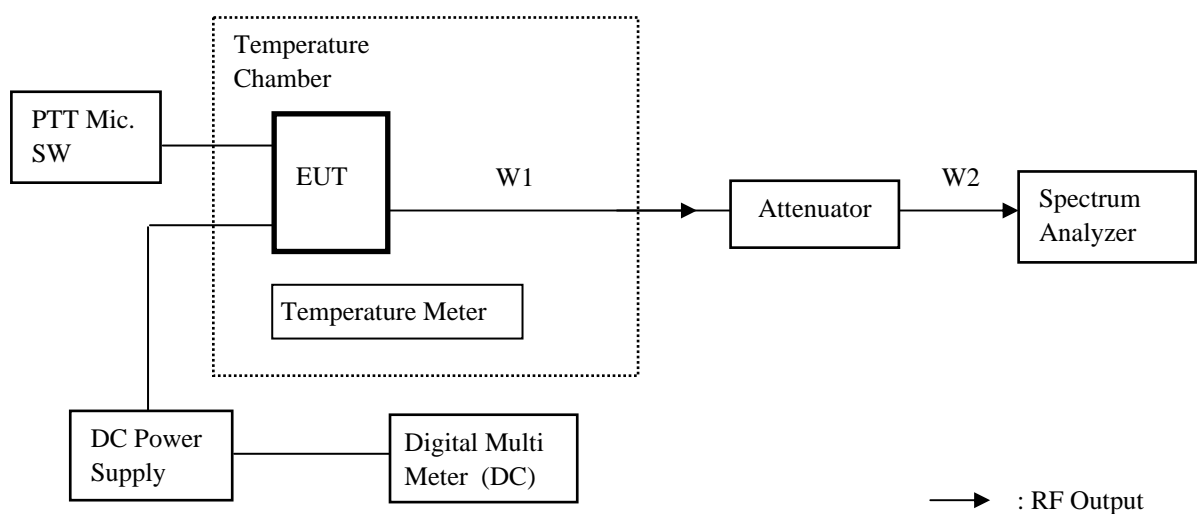

Uncertainty

Measurement uncertainty is +/- 0.2ppm

Test Results

Test carried out for all the frequency band of section 5.1

Measured for the worst case

State : High Power / Authorized Bandwidth 6 kHz / 494.6 MHz

No.	Diviation (%)	Voltage (V)	Frequency (MHz)	Stability (ppm)	Limit (ppm)	Margin (ppm)
1	85	11.7	494.599912	-0.18	0.5	0.32
2	100	13.8	494.600025	0.05	0.5	0.45
3	115	15.9	494.599937	-0.13	0.5	0.37

5.10 Necessary Bandwidth and Emission Bandwidth

REGULATIONS	: 47 CFR 2.202 (g) & Federal Register/ Vol.68, No236 TRC 43
-------------	--

Calculation Results

State : 16K0F3E (Authorized Bandwidth 20 kHz)

Item	Mark	
Maximum Modulation	(M)	3kHz
Maximum Deviation	(D)	5kHz
Constant Factor	(K)	1
Necessary Bandwidth	(Bn)	16kHz

$$B_n = (2 \times M) + (2 \times D \times K)$$

State : 11K0F3E (Authorized Bandwidth 11.25 kHz)

Item	Mark	
Maximum Modulation	(M)	3kHz
Maximum Deviation	(D)	2.5kHz
Constant Factor	(K)	1
Necessary Bandwidth	(Bn)	11kHz

$$B_n = (2 \times M) + (2 \times D \times K)$$

State : 8K30F1D / 8K30F1E / 8K30F7W (4Level FSK /9600bps, Authorized Bandwidth 11.25 kHz)

Item	Mark	
Digital information rate	(R)	9600bps
Peak frequency deviation	(D)	3.391kHz
Signaling states	(S)	4
Numerical factor	(K)	0.516
Necessary Bandwidth	(Bn)	8.3kHz

$$B_n = (R / \log_2 S) + 2 \times D \times K$$

State : 4K00F1E / 4K00F1D / 4K00F7W (4Level FSK /4800bps, Authorized Bandwidth 6 kHz)

Item	Mark	
Digital information rate	(R)	4800bps
Peak frequency deviation	(D)	1.550kHz
Signaling states	(S)	4
Numerical factor	(K)	0.516
Necessary Bandwidth	(Bn)	4.0kHz

$$B_n = (R / \log_2 S) + 2 \times D \times K$$

State : 4K00F2D (CWID, Authorized Bandwidth 6 kHz)

Item	Mark	
Maximum Modulation	(M)	0.8kHz
Maximum Deviation	(D)	1.2kHz
Numerical factor	(K)	1
Necessary Bandwidth	(Bn)	4.0kHz

$$B_n = (2 \times M) + (2 \times D \times K)$$



6. VALIDITY OF TEST REPORT





The test result of this report is effective for equipment under test itself and under the test configuration described on the report.

This test report does not assure that whether the test result taken in other testing laboratory is compatible or reproducible to the test result on this report or not.

Copying of this report without permission is prohibited.

7. DESCRIPTION OF TEST LABORATORY

ACCREDITATION			SCOPE	LAB. CODE
 <small>LAB CODE 100290-0</small>	NVLAP	USA	EMC Testing	100290-0
	NVLAP	USA	Calibration	100290-0
	NVLAP	USA	Telecommunication	100290-0
	VLAC	JAPAN	EMC Testing	VLAC-008-1
	BSMI	TAIWAN	EMC Testing	SL2-IN-E-6008
	NATA	AUSTRALIA	Calibration	13491
	NATA	AUSTRALIA	Telecommunication	100290-0

FILING			SCOPE	LAB. CODE
	VCCI	JAPAN	EMC Testing	
	FCC	USA	EMC Testing	JP0008
	IC	CANADA	EMC Testing	IC-2065A-1
	IC	CANADA	Telecommunication	IC-2065A
		SAUDI ARABIA	EMC Testing	

Note 1 : NVLAP accreditation does not constitute any product endorsement by NVLAP or any agent of the U.S. Government.