



SAR TEST REPORT

HCT CO., LTD

EUT Type:	GSM/WCDMA Phone with Bluetooth & WLAN GPRS Class10 and GPRS mode class B(GPRS and GSM, but not simultaneously)	
FCC ID:	JYCP8000	
Model:	P8000	
Date of Issue:	Mar.22, 2011	
Test report No.:	HCTA1103FS06	
Test Laboratory:	HCT CO., LTD. SAN 136-1, AMI-RI, BUBAL-EUP, ICHEON-SI, KYOUNGKI-DO, 467-701, KOREA TEL: +82 31 639 8565 FAX: +82 31 639 8525	
Applicant :	Pantech Co., Ltd. Pantech Building, I-2, DMC, Sangam-dong, Mapo-gu, Seoul, Korea(ZIP :121-792) Tel: 82-2-2030-1319 Fax: 82-2-2030-2500	
Testing has been carried out in accordance with:	RSS-102 Issue 4; Health Canada Safety Code 6 47CFR §2.1093 FCC OET Bulletin 65(Edition 97-01), Supplement C (Edition 01-01) ANSI/ IEEE C95.1 – 2005 IEEE 1528-2003	
Test result:	The tested device complies with the requirements in respect of all parameters subject to the test. The test results and statements relate only to the items tested. The test report shall not be reproduced except in full, without written approval of the laboratory.	
Signature	 _____ Report prepared by : Young-Soo Jang Test Engineer of SAR Part	 _____ Approved by : Jae-Sang So Manager of SAR Part

Table of Contents

1. INTRODUCTION	3
2. DESCRIPTION OF DEVICE.....	4
3. DESCRIPTION OF TEST EQUIPMENT	5
4. SAR MEASUREMENT PROCEDURE.....	1 2
5. DESCRIPTION OF TEST POSITION.....	1 3
6. MEASUREMENT UNCERTAINTY.....	1 5
7. ANSI/ IEEE C95.1 - 2005 RF EXPOSURE LIMITS	1 6
8. SYSTEM VERIFICATION.....	1 7
9. TEST CONFIGURATIONS.....	1 8
10. RF CONDUCTED POWER	1 9
11. Mobile Hotspot Side for SAR Testing	2 3
12. SAR Evaluation Considerations for Handsets with Multiple Transmitters and Antennas.....	2 4
13. SAR TEST DATA SUMMARY	2 9
13.1 Measurement Results (GSM850 Head SAR Touch)	2 9
13.2 Measurement Results (GSM850 Head SAR Tilt)	3 0
13.3 Measurement Results (GSM1900 Head SAR Touch)	3 1
13.4 Measurement Results (GSM1900 Head SAR Tilt)	3 2
13.5 Measurement Results (WCDMA850 Head SAR Touch).....	3 3
13.6 Measurement Results (WCDMA850 Head SAR Tilt)	3 4
13.7 Measurement Results (WCDMA1900 Head SAR Touch).....	3 5
13.8 Measurement Results (WCDMA1900 Head SAR Tilt).....	3 6
13.9 Measurement Results (802.11b/g/n Head SAR Touch)	3 7
13.10 Measurement Results (802.11b/g/n Head SAR Tilt).....	3 8
13.11 Measurement Results (GSM850 Body SAR).....	3 9
13.12 Measurement Results (GSM1900 Body SAR).....	4 0
13.13 Measurement Results (WCDMA850 Body SAR)	4 1
13.14 Measurement Results (WCDMA1900 Body SAR)	4 2
13.15 Measurement Results (802.11b/g/n Body SAR)	4 3
13.16 Measurement Results (GSM850 Hotspot Body SAR)	4 4
13.17 Measurement Results (GSM1900 Hotspot Body SAR)	4 5
13.18 Measurement Results (WCDMA850 Hotspot Body SAR).....	4 6
13.19 Measurement Results (WCDMA1900 Hotspot Body SAR).....	4 7
13.20 Measurement Results (802.11b/g/n Module Body SAR)	4 8
14. CONCLUSION.....	4 9
15. REFERENCES	5 0
Attachment 1. – SAR Test Plots	5 1
Attachment 3. – Probe Calibration Data	1 5 3
Attachment 4. – Dipole Calibration Data	1 8 0

1. INTRODUCTION

The FCC has adopted the guidelines for evaluating the environmental effects of radio frequency radiation in ET Docket 93-62 on Aug. 6, 1996 to protect the public and workers from the potential hazards of RF emissions due to FCC-regulated portable devices.

The safety limits used for the environmental evaluation measurements are based on the criteria published by the American National Standards Institute (ANSI) for localized specific absorption rate (SAR) in IEEE/ANSI C95.1-2005 Standard for Safety Levels with Respect to Human Exposure to Radio Frequency Electromagnetic Fields, 3 kHz to 300 GHz. 1992 by the Institute of Electrical and Electronics Engineers, Inc., New York, New York 10017. The measurement procedure described in IEEE/ANSI C95.3-1992 Recommended Practice for the Measurement of Potentially Hazardous Electromagnetic Fields - RF and Microwave is used for guidance in measuring SAR due to the RF radiation exposure from the Equipment Under Test (EUT). These criteria for SAR evaluation are similar to those recommended by the National Council on Radiation Protection and Measurements (NCRP) in Biological Effects and Exposure Criteria for Radio frequency Electromagnetic Fields," NCRP Report No. 86 NCRP, 1986, Bethesda, MD 20814. SAR is a measure of the rate of energy absorption due to exposure to an RF transmitting source. SAR values have been related to threshold levels for potential biological hazards.

SAR Definition

Specific Absorption Rate (SAR) is defined as the time derivative of the incremental electromagnetic energy (dW) absorbed by (dissipated in) an incremental mass (dm) contained in a volume element (dV) of a given density (ρ). It is also defined as the rate of RF energy absorption per unit mass at a point in an absorbing body.

$$SAR = \frac{d}{dt} \left(\frac{dU}{dm} \right) = \frac{d}{dt} \left(\frac{dU}{\rho dV} \right)$$

Figure 2. SAR Mathematical Equation

SAR is expressed in units of Watts per Kilogram (W/kg).

$$SAR = \sigma E^2 / \rho$$

where:

σ	=	conductivity of the tissue-simulant material (S/m)
ρ	=	mass density of the tissue-simulant material (kg/m ³)
E	=	Total RMS electric field strength (V/m)

NOTE: The primary factors that control rate of energy absorption were found to be the wavelength of the incident field in relations to the dimensions and geometry of the irradiated organism, the orientation of the organism in relation to the polarity of field vectors, the presence of reflecting surfaces, and whether conductive contact is made by the organism with a ground plane.

2. DESCRIPTION OF DEVICE

Environmental evaluation measurements of specific absorption rate (SAR) distributions in emulated human head and body tissues exposed to radio frequency (RF) radiation from wireless portable devices for compliance with the rules and regulations of the U.S. Federal Communications Commission (FCC).

EUT Type	GSM/WCDMA Phone with Bluetooth & WLAN GPRS Class10 and GPRS mode class B(GPRS and GSM, but not simultaneously)		
FCC ID:	JYCP8000		
Model:	P8000		
Trade Name	Pantech	Serial Number(s)	#1
Application Type	Certification		
Mode(s) of Operation	GSM850/GSM1900/WCDMA850/WCDMA1900/802.11b/g/n		
Tx Frequency	824.20 - 848.80 MHz (GSM850) 1 850.20 – 1 909.80 MHz (GSM1900) 826.4~846.6 MHz (WCDMA850) 1 852.4 – 1 907.6 MHz (WCDMA1900) 2 412- 2 462 MHz (DSSS/ OFDM)		
Rx Frequency	869.20 - 893.80 MHz (GSM850) 1 930.20 – 1 989.80 MHz (GSM1900) 871.4 - 891.6 MHz (WCDMA850) 1 932.4 – 1 987.6 MHz (WCDMA1900) 2 412- 2 462 MHz (DSSS/ OFDM)		
FCC Classification	Licensed Portable Transmitter Held to Ear (PCE)		
Production Unit or Identical Prototype	Prototype		
Max SAR	0.381 W/kg GSM850 Head SAR / 1.24 W/kg GSM850 Body SAR 0.567 W/kg GSM1900 Head SAR / 0.996 W/kg GSM1900 Body SAR 0.353 W/kg WCDMA850 Head SAR / 0.617 W/kg WCDMA850 Body SAR 1.16 W/kg WCDMA1900 Head SAR / 1.16 W/kg WCDMA1900 Body SAR 0.768 W/kg Wi-Fi 802.11b / 0.343 W/kg Wi-Fi 802.11b		
Date(s) of Tests	Nov.15, 2010 ~ Nov.16, 2010, Dec. 7,2010, Mar.20, 2011~ Mar.21, 2011		
Antenna Type	Intenna		

3. DESCRIPTION OF TEST EQUIPMENT

3.1 SAR MEASUREMENT SETUP

These measurements are performed using the DASY4 automated dosimetric assessment system. It is made by Schmid & Partner Engineering AG (SPEAG) in Zurich, Switzerland. It consists of high precision robotics system (Staubli), robot controller, Pentium III computer, near-field probe, probe alignment sensor, and the generic twin phantom containing the brain equivalent material. The robot is a six-axis industrial robot performing precise movements to position the probe to the location (points) of maximum electromagnetic field (EMF) (see Figure.3.1).

A cell controller system contains the power supply, robot controller, teach pendant (Joystick), and remote control, is used to drive the robot motors. The PC consists of the HP Pentium IV 3.0 GHz computer with Windows XP system and SAR Measurement Software DASY4, A/D interface card, monitor, mouse, and keyboard. The Staubli Robot is connected to the cell controller to allow software manipulation of the robot. A data acquisition electronic (DAE) circuit performs the signal amplification, signal multiplexing, AD-conversion, offset measurements, mechanical surface detection, collision detection, etc. is connected to the Electro-optical coupler (EOC). The EOC performs the conversion from the optical into digital electric signal of the DAE and transfers data to the PC plug-in card.

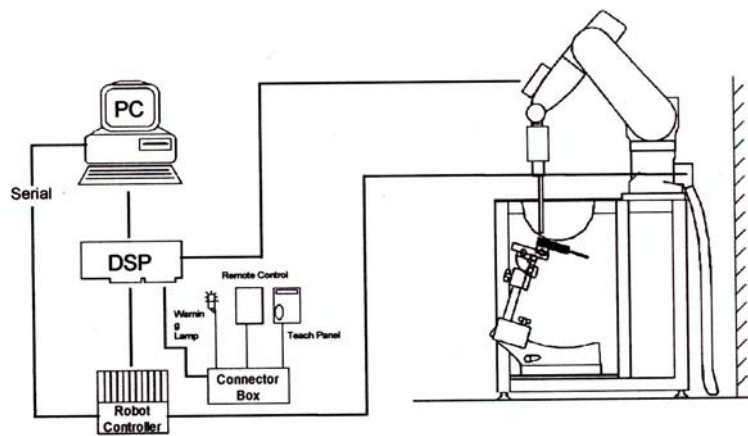

Figure 3.1 HCT SAR Lab. Test Measurement Set-up

The DAE4 consists of a highly sensitive electrometer-grade preamplifier with auto-zeroing, a channel and gain-switching multiplexer, a fast 16 bit AD-converter and a command decoder and control logic unit. Transmission to the PC-card is accomplished through an optical downlink for data and status information and an optical uplink for commands and clock lines. The mechanical probe mounting device includes two different sensor systems for frontal and sidewise probe contacts. They are also used for mechanical surface detection and probe collision detection. The robot uses its own controller with a built in VME-bus computer. The system is described in detail in.

3.2 DASYS4 E-FIELD PROBE SYSTEM

3.2.1 ES3DV3 Probe Specification

Construction	Symmetrical design with triangular core Interleaved sensors Built-in shielding against static charges PEEK enclosure material (resistant to organic solvents, e.g., DGBE)
Calibration	Basic Broad Band Calibration in air Conversion Factors (CF) for HSL 900 and HSL 1810 Additional CF for other liquids and frequencies upon request
Frequency	10 MHz to 4 GHz; Linearity: ± 0.2 dB (30 MHz to 4 GHz)
Directivity	± 0.2 dB in HSL (rotation around probe axis) ± 0.3 dB in tissue material (rotation normal to probe axis)
Dynamic Range	5 μ W/g to > 100 mW/g; Linearity: ± 0.2 dB
Dimensions	Overall length: 330 mm (Tip: 20 mm) Tip diameter: 3.9 mm (Body: 12 mm) Distance from probe tip to dipole centers: 2.0 mm
Application	General dosimetry up to 4 GHz Dosimetry in strong gradient fields Compliance tests of mobile phones

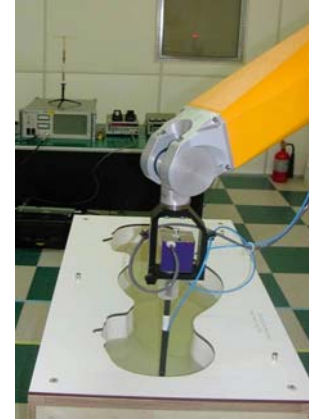

Figure 3.1 Photograph of the probe and the Phantom



Figure 3.2 ES3DV3 E-field Probe

The SAR measurements were conducted with the dosimetric probe ET3DV6, designed in the classical triangular configuration and optimized for dosimetric evaluation. The probe is constructed using the thick film technique; with printed resistive lines on ceramic substrates. The probe is equipped with an optical multifiber line ending at the front of the probe tip. It is connected to the EOC box on the robot arm and provides an automatic detection of the phantom surface. Half of the fibers are connected to a pulsed infrared transmitter, the other half to a synchronized receiver. As the probe approaches the surface, the reflection from the surface produces a coupling from the transmitting to the receiving fibers. This reflection increases first during the approach, reaches a maximum and then decreases. If the probe is flatly touching the surface, the coupling is zero. The distance of the coupling maximum to the surface is independent of the surface effectivity and largely independent of the surface to probe angle. The DASYS4 software reads the reflection during a software approach and looks for the maximum using a 2nd order fitting. The approach is stopped at reaching the maximum.

3.3 PROBE CALIBRATION PROCESS

3.3.1 E-Probe Calibration

Each probe is calibrated according to a dosimetric assessment procedure with an accuracy better than ± 10 %. The spherical isotropy was evaluated with the proper procedure and found to be better than ± 0.25 dB. The sensitivity parameters (NormX, NormY, NormZ), the diode compression parameter (DCP) and the conversion factor (ConvF) of the probe is tested.

The free space E-field from amplified probe outputs is determined in a test chamber. This is performed in a TEM cell for frequencies bellow 1 GHz, and in a waveguide above 1 GHz for free space. For the free space calibration, the probe is placed in the volumetric center of the cavity and at the proper orientation with the field. The probe is then rotated 360 degrees.

E-field temperature correlation calibration is performed in a flat phantom filled with the appropriate simulated brain tissue. The measured free space E-field in the medium correlates to temperature rise in a dielectric medium. For temperature correlation calibration a RF transparent thermistor-based temperature probe is used in conjunction with the E-field probe.

$$SAR = C \frac{\Delta T}{\Delta t}$$

where:

- Δt = exposure time (30 seconds),
- C = heat capacity of tissue (brain or muscle),
- ΔT = temperature increase due to RF exposure.

SAR is proportional to $\Delta T / \Delta t$, the initial rate of tissue heating, before thermal diffusion takes place. Now it's possible to quantify the electric field in the simulated tissue by equating the thermally derived SAR to the E- field;

$$SAR = \frac{|E|^2 \cdot \sigma}{\rho}$$

where:

- σ = simulated tissue conductivity,
- ρ = Tissue density (1.25 g/cm³ for brain tissue)

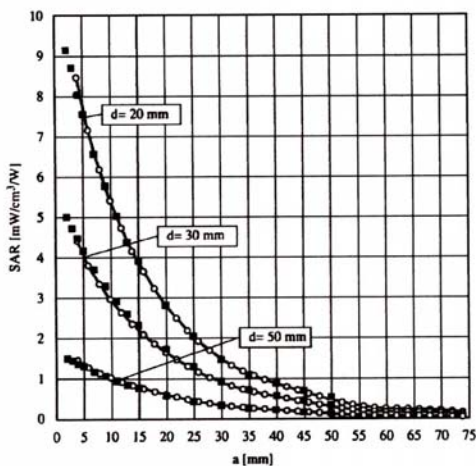

Figure 3.4 E-Field and Temperature measurements at 900 MHz

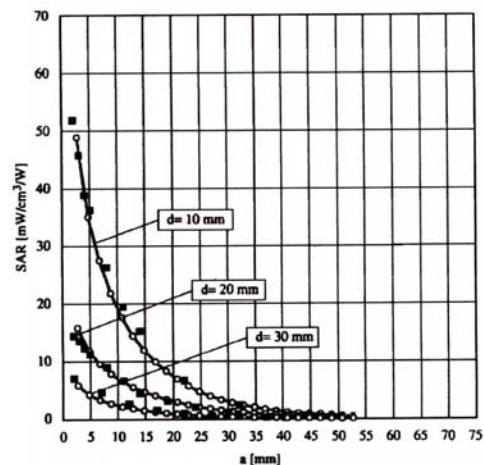

Figure 3.5 E-Field and temperature measurements at 1.8 GHz

3.3.2 Data Extrapolation

The DASY4 software automatically executes the following procedures to calculate the field units from the microvolt readings at the probe connector. The first step of the evaluation is a linearization of the filtered input signal to account for the compression characteristics of the detector diode. The compensation depends on the input signal, the diode type and the DC-transmission factor from the diode to the evaluation electronics. If the exciting field is pulsed, the crest factor of the signal must be known to correctly compensate for peak power. The formula for each channel can be given like below;

$$V_i = U_i + U_i^2 \cdot \frac{cf}{dcp_i}$$

with V_i = compensated signal of channel i (i=x,y,z)
 U_i = input signal of channel i (i=x,y,z)
 cf = crest factor of exciting field (DASY parameter)
 dcp_i = diode compression point (DASY parameter)

From the compensated input signals the primary field data for each channel can be evaluated:

E-field probes:

$$E_i = \sqrt{\frac{V_i}{Norm_i \cdot ConvF}}$$

with V_i = compensated signal of channel i (i = x,y,z)
 $Norm_i$ = sensor sensitivity of channel i (i = x,y,z)
 $\mu V/(V/m)^2$ for E-field probes
 $ConvF$ = sensitivity of enhancement in solution
 E_i = electric field strength of channel i in V/m

The RSS value of the field components gives the total field strength (Hermetian magnitude):

$$E_{tot} = \sqrt{E_x^2 + E_y^2 + E_z^2}$$

The primary field data are used to calculate the derived field units.

$$SAR = E_{tot}^2 \cdot \frac{\sigma}{\rho \cdot 1000}$$

with SAR = local specific absorption rate in W/g
 E_{tot} = total field strength in V/m
 σ = conductivity in [mho/m] or [Siemens/m]
 ρ = equivalent tissue density in g/cm³

The power flow density is calculated assuming the excitation field to be a free space field.

$$P_{pwe} = \frac{E_{tot}^2}{3770}$$

with P_{pwe} = equivalent power density of a plane wave in W/cm²
 E_{tot} = total electric field strength in V/m

3.4 SAM Phantom

The SAM Phantom is constructed of a fiberglass shell integrated in a wooden table. The shape of the shell is based on data from an anatomical study designed to determine the maximum exposure in at least 90 % of all users. It enables the dosimetric evaluation of left and right hand phone usage as well as body mounted usage at the flat phantom region. A cover prevents the evaporation of the liquid. Reference markings on the Phantom allow the complete setup of all predefined phantom positions and measurement grids by manually teaching three points in the robot.

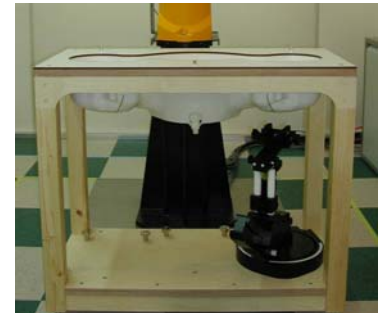

Figure 3.6 SAM Phantom

Shell Thickness	2.0 mm
Filling Volume	about 30 L
Dimensions	810 mm x 1 000 mm x 500 mm (H x L x W)

3.5 Device Holder for Transmitters

In combination with the SAM Phantom V 4.0, the Mounting Device (POM) enables the rotation of the mounted transmitter in spherical coordinates whereby the rotation points is the ear opening. The devices can be easily, accurately, and repeatably positioned according to the FCC and CENELEC specifications. The device holder can be locked at different phantom locations (left head, right head, flat phantom).

Note: A simulating human hand is not used due to the complex anatomical and geometrical structure of the hand that may produce an infinite number of configurations. To produce the Worst-case condition (the hand absorbs antenna output power), the hand is omitted during the tests.



Figure 3.7 Device Holder

3.6 Brain & Muscle Simulating Mixture Characterization

The brain and muscle mixtures consist of a viscous gel using hydrox-ethyl cellulose (HEC) gelling agent and saline solution (see Table 3.1). Preservation with a bactericide is added and visual inspection is made to make sure air bubbles are not trapped during the mixing process. The mixture is calibrated to obtain proper dielectric constant (permittivity) and conductivity of the desired tissue. The mixture characterizations used for the brain and muscle tissue simulating liquids are according to the data by C. Gabriel and G. Hartsgrove.

Ingredients (% by weight)	Frequency (MHz)									
	450		835		915		1 900		2 450	
Tissue Type	Head	Body	Head	Body	Head	Body	Head	Body	Head	Body
Water	38.56	51.16	41.45	52.4	41.05	56.0	54.9	40.4	62.7	73.2
Salt (NaCl)	3.95	1.49	1.45	1.4	1.35	0.76	0.18	0.5	0.5	0.04
Sugar	56.32	46.78	56.0	45.0	56.5	41.76	0.0	58.0	0.0	0.0
HEC	0.98	0.52	1.0	1.0	1.0	1.21	0.0	1.0	0.0	0.0
Bactericide	0.19	0.05	0.1	0.1	0.1	0.27	0.0	0.1	0.0	0.0
Triton X-100	0.0	0.0	0.0	0.0	0.0	0.0	0.0	0.0	36.8	0.0
DGBE	0.0	0.0	0.0	0.0	0.0	0.0	44.92	0.0	0.0	26.7

Salt:	99 % Pure Sodium Chloride	Sugar:	98 % Pure Sucrose
Water:	De-ionized, 16M resistivity	HEC:	Hydroxyethyl Cellulose
DGBE:	99 % Di(ethylene glycol) butyl ether,[2-(2-butoxyethoxy) ethanol]		
Triton X-100(ultra pure):	Polyethylene glycol mono[4-(1,1,3,3-tetramethylbutyl)phenyl] ether		

Table 3.1 Composition of the Tissue Equivalent Matter

3.7 SAR TEST EQUIPMENT

Manufacturer	Type / Model	S/N	Calib. Date	Calib.Interval	Calib.Due
SPEAG	SAM Phantom	-	N/A	N/A	N/A
Staubli	Robot RX90L	F01/5K09A1/A/01	N/A	N/A	N/A
Staubli	Robot ControllerCS7MB	F99/5A82A1/C/01	N/A	N/A	N/A
HP	Pavilion t000_puffer	KRJ51201TV	N/A	N/A	N/A
SPEAG	Light Alignment Sensor	265	N/A	N/A	N/A
Staubli	Teach Pendant (Joystick)	D221340.01	N/A	N/A	N/A
SPEAG	DAE3	446	Sep. 21, 2010	Annual	Sep. 21, 2011
SPEAG	DAE4	869	Sep. 21, 2010	Annual	Sep. 21, 2011
SPEAG	E-Field Probe ES3DV3	3161	Mar 22, 2010	Annual	Mar 22, 2011
SPEAG	E-Field Probe ET3DV6	1630	Mar 25, 2010	Annual	Mar 25, 2011
SPEAG	Validation Dipole D450V2	1007	July 15, 2010	Biennial	July 15, 2012
SPEAG	Validation Dipole D835V2	441	May 21, 2010	Annual	May 21, 2011
SPEAG	Validation Dipole D1800V2	2d006	Apr. 20, 2010	Biennial	Apr. 20, 2012
SPEAG	Validation Dipole D1900V2	5d032	July 16, 2010	Annual	July 16, 2011
SPEAG	Validation Dipole D2450V2	743	Aug. 25, 2010	Biennial	Aug. 27, 2012
Agilent	Power Meter(F) E4419B	MY41291386	Nov. 05, 2010	Annual	Nov. 05, 2011
Agilent	Power Sensor(G) 8481	MY41090870	Nov. 05, 2010	Annual	Nov. 05, 2011
HP	Dielectric Probe Kit 85070C	00721521	N/A	N/A	N/A
HP	Dual Directional Coupler	16072	Nov. 05, 2010	Annual	Nov. 05, 2011
R&S	Base Station CMU200	110740	July 26, 2010	Annual	July 26, 2011
Agilent	Base Station E5515C	GB44400269	Feb. 10, 2010	Annual	Feb. 10, 2011
Agilent	Base Station E5515C	GB44400269	Feb. 10, 2011	Annual	Feb. 10, 2012
HP	Signal Generator E4438C	MY42082646	Dec. 24, 2009	Annual	Dec. 24, 2010
HP	Signal Generator E4438C	MY42082646	Dec. 24, 2010	Annual	Dec. 24, 2011
HP	Network Analyzer 8753C	3310J01394	Dec. 04, 2009	Annual	Dec. 04, 2010
HP	Network Analyzer 8753C	3310J01394	Dec. 04, 2010	Annual	Dec. 04, 2011
HP	Network Analyzer 8753ES	MY4000025	Sep. 02, 2010	Annual	Sep. 02, 2011

NOTE:

The E-field probe was calibrated by SPEAG, by the waveguide technique procedure. Dipole Validation measurement is performed by HCT Lab. before each test. The brain simulating material is calibrated by HCT using the dielectric probe system and network analyzer to determine the conductivity and permittivity (dielectric constant) of the brain-equivalent material.

4. SAR MEASUREMENT PROCEDURE

The evaluation was performed with the following procedure:

1. The SAR value at a fixed location above the ear point was measured and was used as a reference value for assessing the power drop.
2. The SAR distribution at the exposed side of the head was measured at a distance of 3.9 mm from the inner surface of the shell. The area covered the entire dimension of the head and the horizontal grid spacing was 20 mm x 20 mm. Based on this data, the area of the maximum absorption was determined by spline interpolation.
3. Around this point, a volume of 32 mm x 32 mm x 30 mm was assessed by measuring 5 x 5 x 7 points. On this basis of this data set, the spatial peak SAR value was evaluated with the following procedure:
 - a. The data at the surface were extrapolated, since the center of the dipoles is 2.7 mm away from the tip of the probe and the distance between the surface and the lowest measuring point is 1.2 mm. The extrapolation was based on a least square algorithm. A polynomial of the fourth order was calculated through the points in z-axes. This polynomial was then used to evaluate the points between the surface and the probe tip.
 - b. The maximum interpolated value was searched with a straight-forward algorithm. Around this maximum the SAR values averaged over the spatial volumes (1 g or 10 g) were computed using the 3D-Spline interpolation algorithm. The 3D-spline is composed of three one-dimensional splines with the "Not a knot" condition (in x, y, and z directions. The volume was integrated with the trapezoidal algorithm. One thousand points (10 x 10 x 10) were interpolated to calculate the average.
 - c. All neighboring volumes were evaluated until no neighboring volume with a higher average value was found.
4. The SAR value, at the same location as procedure #1, was re-measured. If the value changed by more than 5 %, the evaluation is repeated.

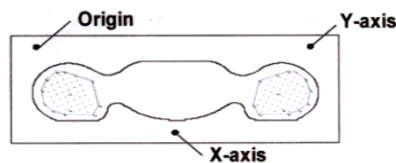

Figure 4.1 SAR Measurement Point in Area Scan

5. DESCRIPTION OF TEST POSITION

5.1 HEAD POSITION

The device was placed in a normal operating position with the Point A on the device, as illustrated in following drawing, aligned with the location of the RE(ERP) on the phantom. With the ear-piece pressed against the head, the vertical center line of the body of the handset was aligned with an imaginary plane consisting of the RE, LE and M. While maintaining these alignments, the body of the handset was gradually moved towards the cheek until any point on the mouth-piece or keypad contacted the cheek. This is a cheek/touch position. For ear/tilt position, while maintain the device aligned with the BM and FN lines, the device was pivot against ERP back for 15° or until the device antenna touch the phantom. Please refer to IEEE 1528-2003 illustration below.

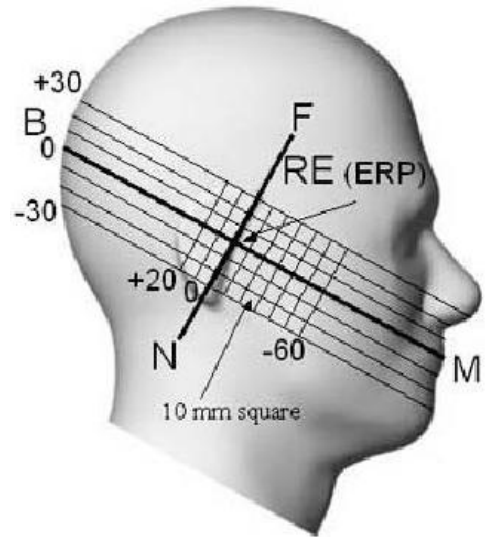

Figure 5.1 Side view of the phantom

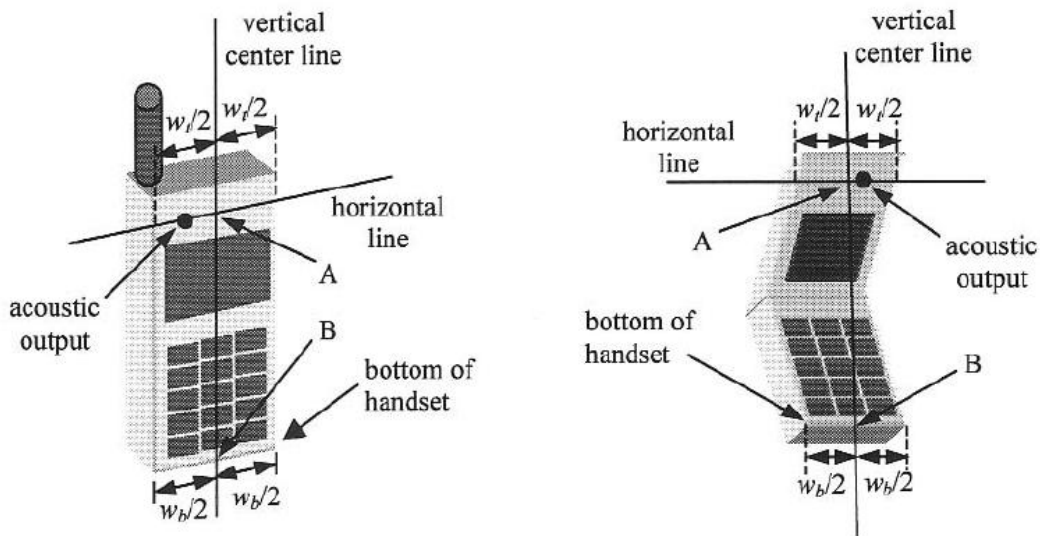

Figure 5.2 Handset vertical and horizontal reference lines

5.2 Body Holster/Belt Clip Configurations

Body-worn operating configurations are tested with the belt-clips and holsters attached to the device and positioned against a flat phantom in a normal use configuration. A device with a headset output is tested with a headset connected to the device. Body dielectric parameters are used.

Accessories for Body-worn operation configurations are divided into two categories: those that do not contain metallic components and those that contain metallic components. When multiple accessories that do not contain metallic components are supplied with the device, the device is tested with only the accessory that dictates the closest spacing to the body. Then multiple accessories that contain metallic components are tested with each accessory. If multiple accessory share an identical metallic component (i.e. the same metallic belt-clip used with different holsters with no other metallic components) only the accessory that dictates the closest spacing to the body is tested.

Body-worn accessories may not always be supplied or available as options for some Devices intended to be authorized for body-worn use. In this case, a test configuration with a separation distance between the back of the device and the flat phantom is used.

Since this EUT does not supply any body worn accessory to the end user a distance of 2.0 cm from the EUT back surface to the liquid interface is configured for the generic test.

"See the Test SET-UP Photo"

Transmitters that are designed to operate in front of a person's face, as in push-to-talk configurations, are tested for SAR compliance with the front of the device positioned to face the flat phantom. For devices that are carried next to the body such as a shoulder, waist or chest-worn transmitters, SAR compliance is tested with the accessory(ies), including headsets and microphones, attached to the device and positioned against a flat phantom in a normal use configuration.

In all cases SAR measurements are performed to investigate the worst-case positioning. Worstcase positioning is then documented and used to perform Body SAR testing.

6. MEASUREMENT UNCERTAINTY

Error Description	Tol (± %)	Prob. dist.	Div.	c_i	Standard Uncertainty (± %)	v_{eff}
1. Measurement System						
Probe Calibration	5.50	N	1	1	5.50	∞
Axial Isotropy	4.70	R	1.73	0.7	1.90	∞
Hemispherical Isotropy	9.60	R	1.73	0.7	3.88	∞
Boundary Effects	1.00	R	1.73	1	0.58	∞
Linearity	4.70	R	1.73	1	2.71	∞
System Detection Limits	1.00	R	1.73	1	0.58	∞
Readout Electronics	0.30	N	1.00	1	0.30	∞
Response Time	0.8	R	1.73	1	0.46	∞
Integration Time	2.6	R	1.73	1	1.50	∞
RF Ambient Noise	3.00	R	1.73	1	1.73	∞
RF Ambient Reflection	3.00	R	1.73	1	1.73	∞
Probe Positioner	0.40	R	1.73	1	0.23	∞
Probe Positioning	2.90	R	1.73	1	1.67	∞
Max SAR Eval	1.00	R	1.73	1	0.58	∞
2. Test Sample Related						
Device Positioning	1.80	N	1.00	1	1.80	9
Device Holder	3.60	N	1.00	1	3.60	5
Power Drift	5.00	R	1.73	1	2.89	∞
3. Phantom and Setup						
Phantom Uncertainty	4.00	R	1.73	1	2.31	∞
Liquid Conductivity(target)	5.00	R	1.73	0.64	1.85	∞
Liquid Conductivity(meas.)	2.07	N	1	0.64	1.32	9
Liquid Permittivity(target)	5.00	R	1.73	0.6	1.73	∞
Liquid Permittivity(meas.)	5.02	N	1	0.6	3.01	9
Combine Standard Uncertainty					10.76	
Coverage Factor for 95 %					$k=2$	
Expanded STD Uncertainty					21.53	

Table 6.1 Uncertainty (800 MHz- 2450 MHz)

7. ANSI/ IEEE C95.1 - 2005 RF EXPOSURE LIMITS

HUMAN EXPOSURE	UNCONTROLLED ENVIRONMENT General Population (W/kg) or (mW/g)	CONTROLLED ENVIRONMENT Occupational (W/kg) or (mW/g)
SPATIAL PEAK SAR * (Brain)	1.60	8.00
SPATIAL AVERAGE SAR ** (Whole Body)	0.08	0.40
SPATIAL PEAK SAR *** (Hands / Feet / Ankle / Wrist)	4.00	20.00

Table 7.1 Safety Limits for Partial Body Exposure

NOTES:

* The Spatial Peak value of the SAR averaged over any 1 g of tissue (defined as a tissue volume in the shape of a cube) and over the appropriate averaging time.

** The Spatial Average value of the SAR averaged over the whole-body.

*** The Spatial Peak value of the SAR averaged over any 10 g of tissue (defined as a tissue volume in the shape of a cube) and over the appropriate averaging time.

Uncontrolled Environments are defined as locations where there is the exposure of individuals who have no knowledge or control of their exposure.

Controlled Environments are defined as locations where there is exposure that may be incurred by persons who are aware of the potential for exposure, (i.e.as a result of employment or occupation).

8. SYSTEM VERIFICATION

8.1 Tissue Verification

Freq. [MHz]	Date	Liquid	Liquid Temp.[°C]	Parameters	Target Value	Measured Value	Deviation [%]	Limit [%]
835	Nov.15, 2010	Head	21.4	ϵr	41.5	42.1	+ 1.45	± 5
				σ	0.90	0.889	- 1.22	± 5
835	Nov.15, 2010	Body	21.4	ϵr	55.2	56.89	+ 3.06	± 5
				σ	0.97	0.98	+ 1.03	± 5
1 900	Nov.16, 2010	Head	21.1	ϵr	40.0	40.9	+ 2.25	± 5
				σ	1.40	1.4	0.00	± 5
1 900	Nov.16, 2010	Body	21.1	ϵr	53.3	53.53	+ 0.43	± 5
				σ	1.52	1.49	- 1.97	± 5
2 450	Nov.16, 2010	Body	21.1	ϵr	52.7	51.7	- 1.89	± 5
				σ	1.95	1.97	- 1.03	± 5
2450	Dec. 7, 2010	Head	21.1	ϵr	39.2	38.2	- 2.55	± 5
				σ	1.80	1.88	+ 4.44	± 5
835	Mar.20, 2011	Body	21.2	ϵr	55.2	56.9	3.08	± 5
				σ	0.97	0.98	1.03	± 5
1 900	Mar.21, 2011	Body	21.3	ϵr	53.3	53.3	0.00	± 5
				σ	1.52	1.58	3.95	± 5
2 450	Mar.21, 2011	Body	21.3	ϵr	52.7	51.6	-2.09	± 5
				σ	1.95	1.96	0.51	± 5

8.2 System Validation

Prior to assessment, the system is verified to the $\pm 10\%$ of the specifications at 835 MHz / 1 900 MHz/ 2 450 MHz by using the system validation kit. (Graphic Plots Attached)

* Input Power: 100 m W

Freq. [MHz]	Date	Liquid	Liquid Temp. [°C]	SAR Average	Target Value (SPEAG) (mW/g)	*Measured Value (mW/g)	Deviation [%]	Limit [%]
835	Nov.15, 2010	Head	21.4	1 g	9.66	0.975	+ 0.93	± 10
1 900	Nov.16, 2010	Head	21.1	1 g	39.9	4.07	+ 2.01	± 10
2 450	Nov.16, 2010	Body	21.1	1 g	54	5.52	+ 2.22	± 10
2 450	Dec. 7, 2010	Head	21.1	1 g	54	5.55	+ 2.77	± 10
835	Mar.20, 2011	Body	21.2	1 g	9.92	1.00	+ 0.81	± 10
1 900	Mar.21, 2011	Body	21.3	1 g	41.5	4.28	+ 3.13	± 10
2 450	Mar.21, 2011	Body	21.3	1 g	54	5.38	- 0.37	± 10

9. TEST CONFIGURATIONS

SAR Testing with IEEE 802.11 a/b/g Transmitters

Normal Network operating configurations are not suitable for measuring the SAR of 802.11 a/b/g transmitters. Unpredictable fluctuations in network traffic and antenna diversity conditions can introduce undesirable variations in SAR results. The SAR for these devices should be measured using chipset based test mode software to ensure the results are consistent and reliable.

9.1 General Device Setup

Chipset based test mode software is hardware dependent and generally varies among manufacturers. The device operating parameters established in test mode for SAR measurements must be identical to those programmed in production units, including output power levels, amplifier gain settings and other RF performance tuning parameters. The test frequencies should correspond to actual channel frequencies defined for domestic use. SAR for devices with switched diversity should be measured with only one antenna transmitting at a time during each SAR measurement, according to a fixed modulation and data rate. The same data pattern should be used for all measurements.

9.2 Frequency Channel Configurations

80.11 a/b/g and 4.9 GHz operating modes are tested independently according to the service requirements in each frequency band. 80.211 b/g modes are tested on channels 1, 6 and 11. 802.11a is tested for UNII operations on channels 36 and 48 in the 5.15-5.25 GHz band; channels 52 and 64 in the 5.25-5.35 GHz band; Channels 104, 116, 124 and 136 in the 5.470-5.725 GHz band; and channels 149 and 161 in the 5.8 GHz band. When 5.8 GHz § 15.247 is also available, channels 149, 157 and 165 should be tested instead of the UNII channels. 4.9 GHz is tested on channels 1, 10 and 5 or 6, whichever has the higher output power, for 5 MHz channels; channels 11, 15 and 19 for 10 MHz channels; and channels 21 and 25 for 20 MHz channels.

These are referred to as the “default test channels”. 802.11g mode was evaluated only if the output power was 0.25 dB higher than the 802.11b mode.

Mode	GHz	Channel	Turbo Channel	“Default Test Channels”		
				§15.247 802.11b	802.11g	UNII
802.11 b/g	2.412	1		√	∇	
	2.437	6	6	√	∇	
	2.462	11		√	∇	
802.11a	5.18	36				√
	5.20	40	42 (5.21 GHz)			*
	5.22	44				*
	5.24	48	50 (5.25 GHz)			√
	5.26	52				√
	5.28	56	58 (5.29 GHz)			*
	5.30	60				*
	5.32	64				√
	5.500	100	Unknown			*
	5.520	104				√
	5.540	108				*
	5.560	112				*
	5.580	116				√
	5.600	120				*
	5.620	124				√
	5.640	128				*
	5.660	132				*
	5.680	136				√
	5.700	140			*	
	UNII or §15.247	5.745	149		√	
5.765		153	152 (5.76 GHz)		*	*
5.785		157		√		*
5.805		161	160 (5.80 GHz)		*	√
§15.247		5.825	165		√	

802.11 Test Channels per FCC Requirements

10. RF CONDUCTED POWER

Power measurements were performed using a base station simulator under digital average power

10.1 Procedures Used to Establish RF Signal for SAR

The handset was placed into a simulated call using a base station simulator in a shielded chamber. Such test signals offer a consistent means for testing SAR and are recommended for evaluation SAR[4] SAR measurements were taken with a fully charged battery. In order to verify that the device was tested and maintained at full power, this was configured with the base station simulator. The SAR measurement Software calculates a reference point at the start and end of the test to check for power drifts. If conducted Power deviations of more than 5 % occurred, the tests were repeated.

10.2 SAR Measurement Conditions for UMTS

Body SAR is not required for handsets with HSDPA capabilities when the maximum average output of each RF channel with HSDPA active is less than ¼ dB higher than that measured without HSDPA using 12.2 kbps RMC and the maximum SAR for 12.2 kbps RMC is ≤ 75 % of the SAR limit. Otherwise, SAR is Measured for HSDPA, using an FRC with H-Set 1 in Sub-test 1 and a 12.2 kbps RMC configured in Test Loop Mode 1, using the highest body SAR configuration in 12.2 kbps RMC without HSDPA, on the maximum output channel with the body exposure configuration that results in the highest SAR in 12.2 kbps RMC for that RF channel.

10.2.1 Output Power Verification

Maximum output power is verified on the High, Middle and Low channels according to the general descriptions in section 5.2 of 3 GPP TS 34.121, using the appropriate RMC or AMR with TPC(transmit power control) set to all "1s"

10.2.2 Head SAR Measurements

SAR for head exposure configurations is measured using the 12.2 kbps RMC with TPC bits configured to all "1s". SAR in AMR configurations is not required when the maximum average output of each RF channel for 12.2 kbps AMR is less than ¼ dB higher than that measured in 12.2 kbps RMC. Otherwise, SAR is measured on the maximum output channel in 12.2 AMR with a 3.4 kbps SRB (signaling radio bearer) using the exposure configuration that results in the highest SAR for that RF channel in 12.2 RMC.

10.2.3 Body SAR Measurement

SAR for body exposure configurations is measured using the 12.2 kbps RMC with the TPC bits all "1s".

10.2.4 Handsets with Release 5 HSDPA

Body SAR is not required for handsets with HSDPA capabilities when the maximum average output of each RF channel with HSDPA active is less than ¼ dB higher than that measured without HSDPA using 12.2 kbps RMC and the maximum SAR for 12.2 kbps RMC is ≤ 75 % of the SAR limit. Otherwise, SAR is Measured for HSDPA, using an FRC with H-Set 1 in Sub-test 1 and a 12.2 kbps RMC configured in Test Loop Mode 1, using the highest body SAR configuration in 12.2 kbps RMC without HSDPA, on the maximum output channel with the body exposure configuration that results in the highest SAR in 12.2 kbps RMC for that RF channel.

Sub-Test 1 Setup for Release 5 HSDPA

Sub-test	β_c	β_a	β_d (SF)	β_c/β_d	$\beta_{hs}^{(1)}$	CM (dB) ⁽²⁾
1	2/15	15/15	64	2/15	4/15	0.0
2	12/15 ⁽³⁾	15/15 ⁽³⁾	64	12/15 ⁽³⁾	24/15	1.0
3	15/15	8/15	64	15/8	30/15	1.5
4	15/15	4/15	64	15/4	30/15	1.5

Note 1: Δ_{ACK} , Δ_{NACK} and $\Delta_{CQI} = 8 \Leftrightarrow A_{hs} = \beta_{hs}/\beta_c = 30/15 \Leftrightarrow \beta_{hs} = 30/15 * \beta_c$

Note 2: CM = 1 for $\beta_c/\beta_d = 12/15$, $\beta_{hs}/\beta_c = 24/15$.

Note 3: For subtest 2 the β_c/β_d ratio of 12/15 for the TFC during the measurement period (TF1, TF0) is achieved by setting the signaled gain factors for the reference TFC (TF1, TF1) to $\beta_c = 11/15$ and $\beta_d = 15/15$.

Band	Channel	Voice	GPRS Data		EDGE Data	
		GSM (dBm)	GPRS 1 TX Slot (dBm)	GPRS 2 TX Slot (dBm)	EDGE 1 TX Slot (dBm)	EDGE 2 TX Slot (dBm)
GSM 850	128	32.63	32.62	32.60	27.22	27.22
	190	32.57	32.57	32.54	27.17	27.17
	251	32.54	32.54	32.52	27.15	27.14
GSM 1900	512	30.31	30.31	30.27	26.38	26.37
	661	30.28	30.28	30.25	26.38	26.36
	810	30.19	30.19	30.17	26.29	26.28

Table 1. GSM Conducted output powers

Band	Channel	Voice	GPRS Data		EDGE Data	
		GSM (dBm)	GPRS 1 TX Slot (dBm)	GPRS 2 TX Slot (dBm)	EDGE 1 TX Slot (dBm)	EDGE 2 TX Slot (dBm)
GSM 850	128	30.57	30.50	30.55	27.12	27.20
	190	30.60	30.56	30.57	27.10	27.19
	251	30.61	30.59	30.58	27.06	27.10
GSM 1900	512	28.02	28.01	27.97	26.34	26.36
	661	28.01	28.10	28.06	26.36	26.35
	810	28.08	28.07	28.09	26.33	26.30

Table 2. GSM Back-off Active Conducted output powers

Note;

This device support CS 1-4 for the GSM/GPRS and MCS 1-9 for the EGPRS.

The Output power measurement & SAR testing were performed with CS4 for GSM/GPRS and MCS5 for EGPRS.

3GPP Release Version	Mode	3GPP 4.121	Cellular Band [dBm]			PCS Band [dBm]			MPR
		Subtest	4132 (826.4)	4183 (836.6)	4233 (846.6)	9262 (1852.4)	9400 (1880.0)	9538 (1907.6)	
99	WCDMA	12.2 kbps RMC	22.76	22.76	22.82	22.62	22.87	22.72	-
5	HSDPA	Subtest 1	22.80	22.82	22.77	22.71	22.95	22.64	0
5		Subtest 2	22.69	22.74	22.68	22.67	22.93	22.60	0
5		Subtest 3	22.23	22.39	22.27	22.36	22.51	22.27	0.5
5		Subtest 4	22.27	22.38	22.18	22.24	22.50	22.21	0.5

Table 3. WCDMA Conducted output powers

3GPP Release Version	Mode	3GPP 4.121	Cellular Band [dBm]			PCS Band [dBm]			MPR
		Subtest	4132 (826.4)	4183 (836.6)	4233 (846.6)	9262 (1852.4)	9400 (1880.0)	9538 (1907.6)	
99	WCDMA	12.2 kbps RMC	21.67	21.75	21.69	21.47	21.49	21.42	-
5	HSDPA	Subtest 1	21.70	21.74	21.65	21.50	21.46	21.40	0
5		Subtest 2	21.61	21.70	21.56	21.61	21.52	21.43	0
5		Subtest 3	21.23	21.26	21.01	21.16	21.13	21.04	0.5
5		Subtest 4	21.20	21.22	21.19	21.02	21.08	21.01	0.5

Table 4. WCDMA Back-off Active Conducted output powers

Band	Channel	Mbps			
		1	2	5.5	11
IEEE 802.11b	1	18.53	18.41	17.11	16.10
	6	18.48	18.29	17.30	16.26
	11	18.59	18.31	17.54	16.34

Table 5.IEEE 802.11b Conducted output power

Band	Channel	Mbps							
		6	9	12	18	24	36	48	54
IEEE 802.11g	1	10.95	10.82	10.79	10.90	10.76	10.97	10.89	10.90
	6	11.25	11.05	11.27	11.30	11.19	11.21	11.32	11.18
	11	11.21	11.20	11.01	11.17	11.32	11.23	11.09	11.25

Table 6.IEEE 802.11g Conducted output power

Band	Channel	Mbps							
		6.5	13	20	26	39	52	58	65
IEEE 802.11n (HT-20)	1	10.94	10.97	10.79	10.84	11.02	10.82	11.04	10.98
	6	10.95	10.87	10.90	11.10	10.98	10.83	10.87	10.99
	11	11.36	11.46	11.30	11.29	11.31	11.43	11.27	11.30

Table 7. IEEE 802.11n Conducted output power

Maximum output target Power & tolerance

The SAR testing were performed at the Maximum power condition.

This device will never operate at higher power levels than that indicated in the below table.

So the SAR values will not be higher than that indicated in the SAR report.

	Back-off Inactive		Back-off Active	
	Max. Tune-up Target(dBm)	tolerance(dB)	Max. Tune-up Target(dBm)	tolerance(dB)
GSM850	32.5	+/-0.5	30.5	+/-0.5
GSM1900	30	+/-0.5	28	+/-0.5
WCDMA850/1900	23	+/-0.5	21.5	+/-0.5

11. Mobile Hotspot Side for SAR Testing

11.1 SAR Test configurations

Mode	Back	Front	EDGE A	EDGE B	EDGE C	EDGE D
850 GPRS	Yes	Yes	Yes	Yes	Yes	No
1900 GPRS	Yes	Yes	Yes	Yes	Yes	No
WCDMA850	Yes	Yes	Yes	Yes	Yes	No
WCDMA1900	Yes	Yes	Yes	Yes	Yes	No
WLAN	Yes	Yes	Yes	No	No	Yes

11.2 Antenna and Device Information

- This device has power back-off capabilities.

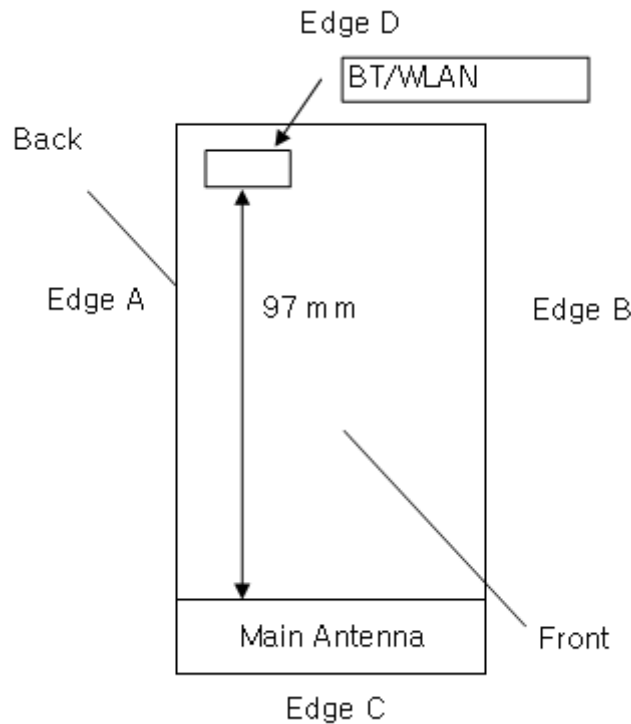

Note;

1. Per Oct.2010 TCB Workshop guidance, we performed the SAR testing at 1 cm from the top & bottom surfaces and also from side edges with a transmitting antenna ≤ 2.5 cm from an edge.
2. When hotspot function is on state, there isn't any change on the transmitter and antenna path. The power level through the antenna path is just backed-off equal to prepared power table. Therefore, the influence of transmitter and antenna path is less than normal state.
3. GSM850/1900 with 2dB Back off +/- 0.5dB power tolerance.
WCDMA with 1.5 dB Back off +/- 0.5dB power tolerance.
GSM voice, GPRS , UMTS voice and HSDPA will have power back off, when Hotspot mode is on. (Only exclude EDGE and WiFi)

12. SAR Evaluation Considerations for Handsets with Multiple Transmitters and Antennas

12.1 SAR Evaluation Considerations

These procedures were followed according to FCC "SAR Evaluation Considerations for Handsets with Multiple Transmitters and Antennas", May 2008. The procedures are applicable to phones with built-in unlicensed transmitters, such as 802.11 a/b/g and Bluetooth devices.

	2.45	5.15 - 5.35	5.47 - 5.85	GHz
P_{Ref}	12	6	5	mW

Device output power should be rounded to the nearest mW to compare with values specified in this

Table. 11.1 Output Power Thresholds for Unlicensed Transmitters

	Individual Transmitter	Simultaneous Transmission
Licensed Transmitters	<u>Routine evaluation required</u>	SAR not required: <u>Unlicensed only</u>
Unlicensed Transmitters	<p><u>When there is no simultaneous transmission –</u></p> <ul style="list-style-type: none"> o output ≤ 60/f: SAR not required o output > 60/f: stand-alone SAR required <p><u>When there is simultaneous transmission – Stand-alone SAR not required when</u></p> <ul style="list-style-type: none"> o output ≤ 2·P_{Ref} and antenna is ≥ 5.0 cm from other antennas o output ≤ P_{Ref} and antenna is ≥ 2.5 cm from other antennas o output ≤ P_{Ref} and antenna is < 2.5 cm from other antennas, each with either output power ≤ P_{Ref} or 1-g SAR < 1.2 W/kg <p><u>Otherwise stand-alone SAR is required</u></p> <p><u>When stand-alone SAR is required</u></p> <ul style="list-style-type: none"> o test SAR on highest output channel for each wireless mode and exposure condition o if SAR for highest output channel is > 50% of SAR limit, evaluate all channels according to normal procedures 	<ul style="list-style-type: none"> o when stand-alone 1-g SAR is not required and antenna is ≥ 5 cm from other antennas <p><u>Licensed & Unlicensed</u></p> <ul style="list-style-type: none"> o when the sum of the 1-g SAR is < 1.6 W/kg for all simultaneous transmitting antennas o when SAR to peak location separation ratio of simultaneous transmitting antenna pair is < 0.3 <p>SAR required: <u>Licensed & Unlicensed</u></p> <p>antenna pairs with SAR to peak location separation ratio ≥ 0.3; test is only required for the configuration that results in the highest SAR in stand-alone configuration for each wireless mode and exposure condition</p> <p>Note: simultaneous transmission exposure conditions for head and body can be different for different style phones; therefore, different test requirements may apply</p>
Jaw, Mouth and Nose	<p><u>Flat phantom SAR required</u></p> <ul style="list-style-type: none"> o when measurement is required in tight regions of SAM and it is not feasible or the results can be questionable due to probe tilt, calibration, positioning and orientation issues o position rectangular and clam-shell phones according to flat phantom procedures and conduct SAR measurements for these specific locations 	When simultaneous transmission SAR testing is required, contact the FCC Laboratory for interim guidance.

Table. 11.2 SAR Evaluation Requirements for Cellphones with Multiple Transmitters

FCC ID: JYCP8000

BT Max. RF output power: 3.80 dBm (2.40 mW)

Antenna separation distance between Main and BT/ WLAN: 95 mm

WLAN Max. RF output power: Wi-Fi 802.11b (18.59 dBm) / Wi-Fi 802.11g (11.32 dBm) / Wi-Fi 802.11n (11.46 dBm)

Because the conducted output power level of the BT transmitter is less than 2·P_{ref}, and the BT antenna is more than 5 cm from the Main antenna, neither simultaneous SAR nor stand-alone BT SAR are required for the EUT. Based on the output power and antenna separation distance, a stand-alone WLAN SAR test is required.

12.2 Simultaneous Transmission

- 3G can transmit simultaneously with BT antenna.
- 3G can transmit simultaneously with WLAN antenna
- WiFi can not transmit simultaneously with BT

Combination	Configuration
1	GSM 850 Voice + WiFi
2	GSM 1900 Voice + WiFi
3	GRPS 850 Data + WiFi
4	GRPS 1900 Data + WiFi
5	EDGE 850 Data + WiFi
6	EDGE 1900 Data + WiFi
7	UMTS 850 Voice + WiFi
8	UMTS 1900 Voice + WiFi
9	HSDPA 850 Data + WiFi
10	HSDPA 1900 Data + WiFi

GPRS Mode Class: B

- WLAN VoIP + GPRS can not transmit simultaneously.
Therefore, GPRS + WLAN Head SAR is not required.
- With Hotspot on, user able to initiate and get the voice call.

2G/3G Voice + WLAN VoIP Simultaneous Transmission for Held to Ear

Simultaneous TX	configuration	850 GSM SAR(W/kg)	WIFI SAR (W/kg)	ΣSAR (W/kg)	Simultaneous TX	configuration	1900 GSM SAR(W/kg)	WIFI SAR (W/kg)	ΣSAR (W/kg)
Head SAR	Right Cheek	0.354	0.671	1.025	Head SAR	Right Cheek	0.353	0.671	1.024
	Right Tilt	0.268	0.768	1.036		Right Tilt	0.232	0.768	1
	Left Cheek	0.381	0.575	0.956		Left Cheek	0.567	0.575	1.142
	Left Tilt	0.291	0.691	0.982		Left Tilt	0.269	0.691	0.96
Simultaneous TX	configuration	850 WCDMA SAR(W/kg)	WIFI SAR (W/kg)	ΣSAR (W/kg)	Simultaneous TX	configuration	1900 WCDMA SAR(W/kg)	WIFI SAR (W/kg)	ΣSAR (W/kg)
Head SAR	Right Cheek	0.305	0.671	0.976	Head SAR	Right Cheek	0.689	0.671	1.36
	Right Tilt	0.212	0.768	0.98		Right Tilt	0.444	0.768	1.212
	Left Cheek	0.353	0.575	0.928		Left Cheek	1.16	0.575	1.735
	Left Tilt	0.232	0.691	0.923		Left Tilt	0.513	0.691	1.204

2G/3G Data + WLAN Simultaneous Transmission for Body Worn with Hotspot Inactive

Simultaneous TX	configuration	850 GSM SAR(W/kg)	WIFI SAR (W/kg)	ΣSAR (W/kg)	Simultaneous TX	configuration	1900 GSM SAR(W/kg)	WIFI SAR (W/kg)	ΣSAR (W/kg)
Body SAR	Back	1.02	0.343	1.363	Body SAR	Back	0.585	0.343	0.928
Simultaneous TX	configuration	850 WCDMA SAR(W/kg)	WIFI SAR (W/kg)	ΣSAR (W/kg)	Simultaneous TX	configuration	1900 WCDMA SAR(W/kg)	WIFI SAR (W/kg)	ΣSAR (W/kg)
Body SAR	Back	0.583	0.343	0.926	Body SAR	Back	0.58	0.343	0.923

Note: WLAN DATA was measured at 1.0cm representing worst-case scenario
2G/3G Data were measured at 2.0 cm

2G/3G Data + WLAN Simultaneous Transmission for Body with Hotspot Active (1.0 cm)

Simultaneous TX	configuration	850 GSM SAR(W/kg)	WIFI SAR (W/kg)	ΣSAR (W/kg)	Simultaneous TX	configuration	1900 GSM SAR(W/kg)	WIFI SAR (W/kg)	ΣSAR (W/kg)
Body SAR	Back	1.24	0.343	1.583	Body SAR	Back	0.996	0.343	1.339
	Front	0.491	0.074	0.565		Front	0.151	0.074	0.225
	Right Edge	0.431	-	0.431		Right Edge	0.112	-	0.112
	Left Edge	0.646	0.034	0.68		Left Edge	0.12	0.034	0.154
	Top Edge	-	0.187	0.187		Top Edge	-	0.187	0.187
	Bottom Edge	0.62	-	0.62		Bottom Edge	0.941	-	0.941
Simultaneous TX	configuration	850 WCDMA SAR(W/kg)	WIFI SAR (W/kg)	ΣSAR (W/kg)	Simultaneous TX	configuration	1900 WCDMA SAR(W/kg)	WIFI SAR (W/kg)	ΣSAR (W/kg)
Body SAR	Back	0.617	0.343	0.96	Body SAR	Back	1.16	0.343	1.503
	Front	0.333	0.074	0.407		Front	0.291	0.074	0.365
	Right Edge	0.318	-	0.318		Right Edge	0.168	-	0.168
	Left Edge	0.426	0.034	0.46		Left Edge	0.166	0.034	0.2

Test Position	Highest 1g SAR (W/kg)		ΣSAR(W/kg)
	3G	WiFi	
Head	1.16	0.575	1.735

ΣSAR(W/kg)	Separation distance of peak location (cm) 3G-to-WiFi	Antenna Pair SAR to Peak Location Separation Ratio
1.735	7.46	0.23

Value of SAR mW/g	X m	Y m	Z m
1.79	0.0645	0.263	-0.174
1.52	0.00584	0.309	-0.171
0.074606			

12.3 Conclusion

The SAR to Peak location separation ration is $0.23 < 0.3$. Therefore a simultaneous SAR evaluation is not required.

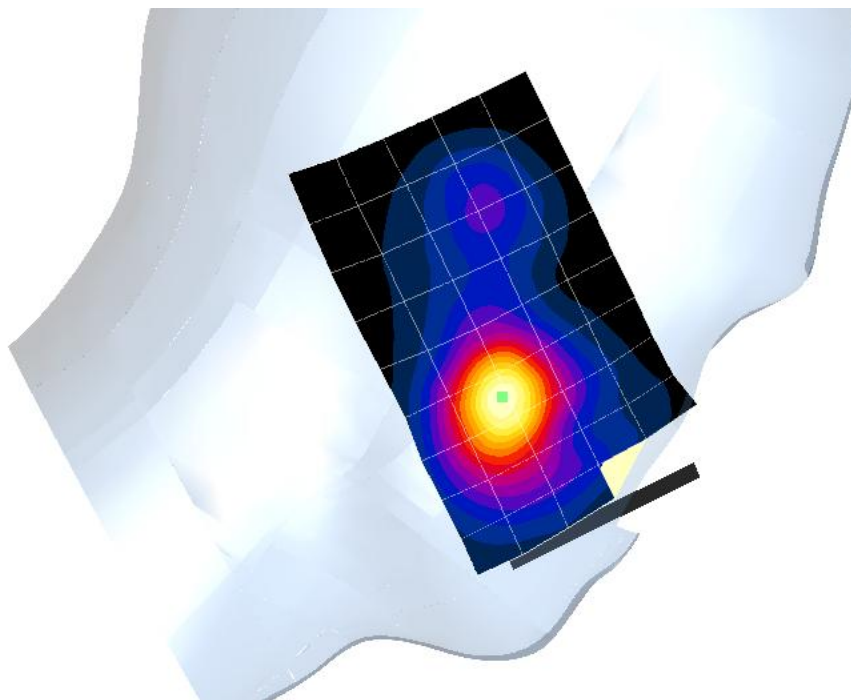

3G Max.SAR Peak Location

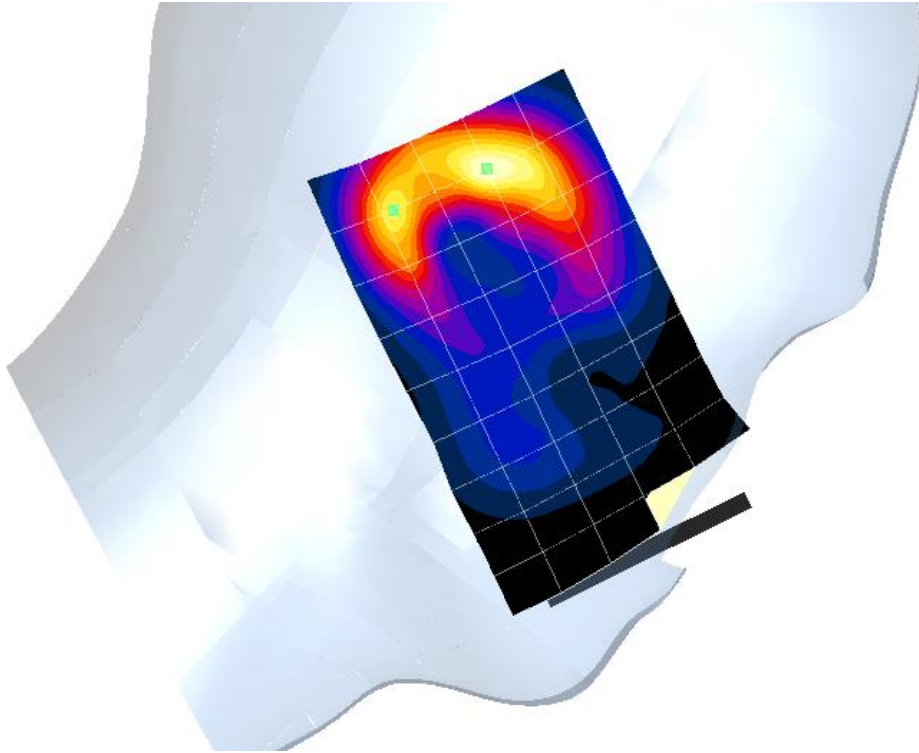

WiFi Max. SAR Peak Location

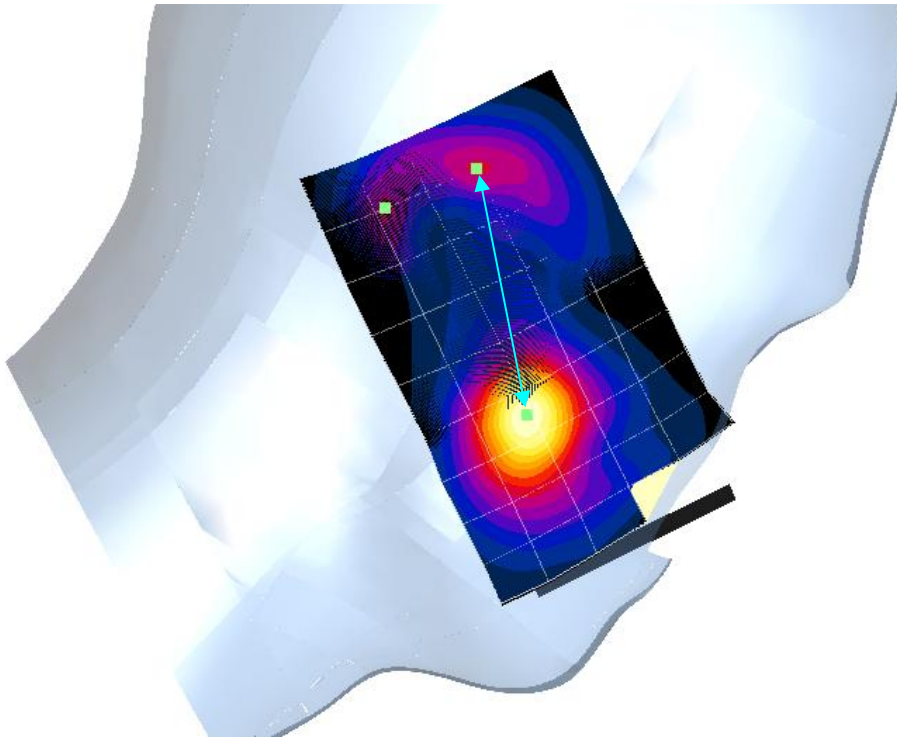

Combined

Separation distance between peaks SAR = 7.46 cm

13. SAR TEST DATA SUMMARY

13.1 Measurement Results (GSM850 Head SAR Touch)

Frequency		Modulation	Conducted Power (dBm)		Battery	Phantom Position	Antenna Type	SAR(mW/g)
MHz	Channel		Begin	End				
836.6	190 (Mid)	GSM850	32.57	32.43	Standard	Left Ear	Intenna	0.381
836.6	190 (Mid)	GSM850	32.57	32.43	Standard	Right Ear	Intenna	0.354
ANSI/ IEEE C95.1 - 1992– Safety Limit						Head		
Spatial Peak						1.6 W/kg (mW/g)		
Uncontrolled Exposure/ General Population						<small>Averaged over 1 gram</small>		

NOTES:

- The test data reported are the worst-case SAR value with the antenna-head position set in a typical configuration. Test procedures used are according to FCC/OET Bulletin 65, Supplement C [July 2001].
- All modes of operation were investigated and the worst-case are reported.
- Measured Depth of Simulating Tissue is 15.0 cm ± 0.2 cm.
- Tissue parameters and temperatures are listed on the SAR plot.
- Battery Type Standard Extended Slim
Batteries are fully charged for all readings.
- Test Signal Call Mode Manual Test cord Base Station Simulator
- Justification for reduced test configurations: per FCC/OET Supplement C (July, 2001), if the SAR measured at the middle channel for each test configuration (Left, right, cheek/touch, tilt/ear, extended and retracted) is at least 3.0 dB lower than the SAR limit, testing at the high and low channels is optional for such test configuration(s).

13.2 Measurement Results (GSM850 Head SAR Tilt)

Frequency		Modulation	Conducted Power (dBm)		Battery	Phantom Position	Antenna Type	SAR(mW/g)
MHz	Channel		Begin	End				
836.6	190 (Mid)	GSM850	32.57	32.60	Standard	Left Tilt 15°	Intenna	0.291
836.6	190 (Mid)	GSM850	32.57	32.58	Standard	Right Tilt 15°	Intenna	0.268
ANSI/ IEEE C95.1 - 1992– Safety Limit						Head		
Spatial Peak						1.6 W/kg (mW/g)		
Uncontrolled Exposure/ General Population						<small>Averaged over 1 gram</small>		

NOTES:

- 1 The test data reported are the worst-case SAR value with the antenna-head position set in a typical configuration. Test procedures used are according to FCC/OET Bulletin 65, Supplement C [July 2001].
- 2 All modes of operation were investigated and the worst-case are reported.
- 3 Measured Depth of Simulating Tissue is 15.0 cm ± 0.2 cm.
- 4 Tissue parameters and temperatures are listed on the SAR plot.
- 5 Battery Type Standard Extended Slim
Batteries are fully charged for all readings.
- 6 Test Signal Call Mode Manual Test cord Base Station Simulator
- 7 Justification for reduced test configurations: per FCC/OET Supplement C (July, 2001), if the SAR measured at the middle channel for each test configuration (Left, right, cheek/touch, tilt/ear, extended and retracted) is at least 3.0 dB lower than the SAR limit, testing at the high and low channels is optional for such test configuration(s).

13.3 Measurement Results (GSM1900 Head SAR Touch)

Frequency		Modulation	Conducted Power (dBm)		Battery	Phantom Position	Antenna Type	SAR(mW/g)
MHz	Channel		Begin	End				
1 880.0	661 (Mid)	GSM1900	30.28	30.21	Standard	Left Ear	Intenna	0.567
1 880.0	661 (Mid)	GSM1900	30.28	30.23	Standard	Right Ear	Intenna	0.353
ANSI/ IEEE C95.1 - 1992– Safety Limit Spatial Peak Uncontrolled Exposure/ General Population						Head 1.6 W/kg (mW/g) Averaged over 1 gram		

NOTES:

- The test data reported are the worst-case SAR value with the antenna-head position set in a typical configuration. Test procedures used are according to FCC/OET Bulletin 65, Supplement C [July 2001].
- All modes of operation were investigated and the worst-case are reported.
- Measured Depth of Simulating Tissue is 15.0 cm ± 0.2 cm.
- Tissue parameters and temperatures are listed on the SAR plot.
- Battery Type Standard Extended Slim
Batteries are fully charged for all readings.
- Test Signal Call Mode Manual Test cord Base Station Simulator
- Justification for reduced test configurations: per FCC/OET Supplement C (July, 2001), if the SAR measured at the middle channel for each test configuration (Left, right, cheek/touch, tilt/ear, extended and retracted) is at least 3.0 dB lower than the SAR limit, testing at the high and low channels is optional for such test configuration(s).

13.4 Measurement Results (GSM1900 Head SAR Tilt)

Frequency		Modulation	Conducted Power (dBm)		Battery	Phantom Position	Antenna Type	SAR(mW/g)
MHz	Channel		Begin	End				
1 880.0	661 (Mid)	GSM1900	30.28	30.22	Standard	Left Tilt 15°	Intenna	0.269
1 880.0	661 (Mid)	GSM1900	30.28	30.14	Standard	Right Tilt 15°	Intenna	0.232
ANSI/ IEEE C95.1 - 1992– Safety Limit Spatial Peak Uncontrolled Exposure/ General Population						Head 1.6 W/kg (mW/g) Averaged over 1 gram		

NOTES:

- The test data reported are the worst-case SAR value with the antenna-head position set in a typical configuration. Test procedures used are according to FCC/OET Bulletin 65, Supplement C [July 2001].
- All modes of operation were investigated and the worst-case are reported.
- Measured Depth of Simulating Tissue is 15.0 cm ± 0.2 cm.
- Tissue parameters and temperatures are listed on the SAR plot.
- Battery Type Standard Extended Slim
Batteries are fully charged for all readings.
- Test Signal Call Mode Manual Test cord Base Station Simulator
- Justification for reduced test configurations: per FCC/OET Supplement C (July, 2001), if the SAR measured at the middle channel for each test configuration (Left, right, cheek/touch, tilt/ear, extended and retracted) is at least 3.0 dB lower than the SAR limit, testing at the high and low channels is optional for such test configuration(s).

13.5 Measurement Results (WCDMA850 Head SAR Touch)

Frequency		Modulation	Conducted Power (dBm)		Battery	Phantom Position	Antenna Type	SAR(mW/g)
MHz	Channel		Begin	End				
836.6	4183 (Mid)	WCDMA850	22.76	22.68	Standard	Left Ear	Intenna	0.353
836.6	4183 (Mid)	WCDMA850	22.76	22.84	Standard	Right Ear	Intenna	0.305
ANSI/ IEEE C95.1 - 1992– Safety Limit						Head		
Spatial Peak						1.6 W/kg (mW/g)		
Uncontrolled Exposure/ General Population						<small>Averaged over 1 gram</small>		

NOTES:

- 1 The test data reported are the worst-case SAR value with the antenna-head position set in a typical configuration. Test procedures used are according to FCC/OET Bulletin 65, Supplement C [July 2001].
- 2 All modes of operation were investigated and the worst-case are reported.
- 3 Measured Depth of Simulating Tissue is 15.0 cm ± 0.2 cm.
- 4 Tissue parameters and temperatures are listed on the SAR plot.
- 5 Battery Type Standard Extended Slim
 Batteries are fully charged for all readings.
- 6 Test Signal Call Mode Manual Test cord Base Station Simulator
- 7 Justification for reduced test configurations: per FCC/OET Supplement C (July, 2001), if the SAR measured at the middle channel for each test configuration (Left, right, cheek/touch, tilt/ear, extended and retracted) is at least 3.0 dB lower than the SAR limit, testing at the high and low channels is optional for such test configuration(s).
- 8 WCDMA Mode was tested under RMC 12.2 kbps and HSDPA Inactive.

13.6 Measurement Results (WCDMA850 Head SAR Tilt)

Frequency		Modulation	Conducted Power (dBm)		Battery	Phantom Position	Antenna Type	SAR(mW/g)
MHz	Channel		Begin	End				
836.6	4183 (Mid)	WCDMA850	22.76	22.75	Standard	Left Tilt 15°	Intenna	0.232
836.6	4183 (Mid)	WCDMA850	22.76	22.77	Standard	Right Tilt 15°	Intenna	0.212
ANSI/ IEEE C95.1 - 1992– Safety Limit						Head		
Spatial Peak						1.6 W/kg (mW/g)		
Uncontrolled Exposure/ General Population						<small>Averaged over 1 gram</small>		

NOTES:

- 1 The test data reported are the worst-case SAR value with the antenna-head position set in a typical configuration. Test procedures used are according to FCC/OET Bulletin 65, Supplement C [July 2001].
- 2 All modes of operation were investigated and the worst-case are reported.
- 3 Measured Depth of Simulating Tissue is 15.0 cm ± 0.2 cm.
- 4 Tissue parameters and temperatures are listed on the SAR plot.
- 5 Battery Type Standard Extended Slim
Batteries are fully charged for all readings.
- 6 Test Signal Call Mode Manual Test cord Base Station Simulator
- 7 Justification for reduced test configurations: per FCC/OET Supplement C (July, 2001), if the SAR measured at the middle channel for each test configuration (Left, right, cheek/touch, tilt/ear, extended and retracted) is at least 3.0 dB lower than the SAR limit, testing at the high and low channels is optional for such test configuration(s).
- 8 WCDMA Mode was tested under RMC 12.2 kbps and HSDPA Inactive.

13.7 Measurement Results (WCDMA1900 Head SAR Touch)

Frequency		Modulation	Conducted Power (dBm)		Battery	Phantom Position	Antenna Type	SAR(mW/g)
MHz	Channel		Begin	End				
1 852.4	9262 (Low)	WCDMA1900	22.62	22.71	Standard	Left Ear	Intenna	1.05
1 880.0	9400 (Mid)	WCDMA1900	22.87	22.80	Standard	Left Ear	Intenna	1.03
1 907.6	9538 (High)	WCDMA1900	22.72	22.63	Standard	Left Ear	Intenna	1.16
1 880.0	9400 (Mid)	WCDMA1900	22.87	22.84	Standard	Right Ear	Intenna	0.689
ANSI/ IEEE C95.1 - 1992– Safety Limit						Head		
Spatial Peak						1.6 W/kg (mW/g)		
Uncontrolled Exposure/ General Population						<small>Averaged over 1 gram</small>		

NOTES:

- 1 The test data reported are the worst-case SAR value with the antenna-head position set in a typical configuration. Test procedures used are according to FCC/OET Bulletin 65, Supplement C [July 2001].
- 2 All modes of operation were investigated and the worst-case are reported.
- 3 Measured Depth of Simulating Tissue is 15.0 cm ± 0.2 cm.
- 4 Tissue parameters and temperatures are listed on the SAR plot.
- 5 Battery Type Standard Extended Slim
Batteries are fully charged for all readings.
- 6 Test Signal Call Mode Manual Test cord Base Station Simulator
- 7 WCDMA Mode was tested under RMC 12.2 kbps and HSDPA Inactive.

13.8 Measurement Results (WCDMA1900 Head SAR Tilt)

Frequency		Modulation	Conducted Power (dBm)		Battery	Phantom Position	Antenna Type	SAR(mW/g)
MHz	Channel		Begin	End				
1 880.0	9400 (Mid)	WCDMA1900	22.87	22.87	Standard	Left Tilt 15°	Intenna	0.513
1 880.0	9400 (Mid)	WCDMA1900	22.87	22.80	Standard	Right Tilt 15°	Intenna	0.444
ANSI/ IEEE C95.1 - 1992– Safety Limit						Head		
Spatial Peak						1.6 W/kg (mW/g)		
Uncontrolled Exposure/ General Population						<small>Averaged over 1 gram</small>		

NOTES:

- 1 The test data reported are the worst-case SAR value with the antenna-head position set in a typical configuration. Test procedures used are according to FCC/OET Bulletin 65, Supplement C [July 2001].
- 2 All modes of operation were investigated and the worst-case are reported.
- 3 Measured Depth of Simulating Tissue is 15.0 cm ± 0.2 cm.
- 4 Tissue parameters and temperatures are listed on the SAR plot.
- 5 Battery Type Standard Extended Slim
Batteries are fully charged for all readings.
- 6 Test Signal Call Mode Manual Test cord Base Station Simulator
- 7 Justification for reduced test configurations: per FCC/OET Supplement C (July, 2001), if the SAR measured at the middle channel for each test configuration (Left, right, cheek/touch, tilt/ear, extended and retracted) is at least 3.0 dB lower than the SAR limit, testing at the high and low channels is optional for such test configuration(s).
- 8 WCDMA Mode was tested under RMC 12.2 kbps and HSDPA Inactive.

13.9 Measurement Results (802.11b/g/n Head SAR Touch)

Frequency		Modulation	Conducted Power (dBm)		Battery	Phantom Position	Data Rate	SAR(mW/g)
MHz	Channel		Begin	End				
2437	6 (Mid)	802.11b	18.48	18.46	Standard	Left Ear	1 Mbps	0.575
2437	6 (Mid)	802.11b	18.48	18.37	Standard	Right Ear	1 Mbps	0.671
ANSI/ IEEE C95.1 - 1992– Safety Limit Spatial Peak Uncontrolled Exposure/ General Population						Head 1.6 W/kg (mW/g) Averaged over 1 gram		

NOTES:

- 1 The test data reported are the worst-case SAR value with the antenna-head position set in a typical configuration. Test procedures used are according to FCC/OET Bulletin 65, Supplement C [July 2001].
- 2 All modes of operation were investigated and the worst-case are reported.
- 3 Measured Depth of Simulating Tissue is 15.0 cm ± 0.2 cm.
- 4 Tissue parameters and temperatures are listed on the SAR plot.
- 5 Battery Type Standard Extended Slim
Batteries are fully charged for all readings.
- 6 Test Signal Call Mode Manual Test cord Base Station Simulator

13.10 Measurement Results (802.11b/g/n Head SAR Tilt)

Frequency		Modulation	Conducted Power (dBm)		Battery	Phantom Position	Data Rate	SAR(mW/g)
MHz	Channel		Begin	End				
2437	6 (Mid)	802.11b	18.48	18.51	Standard	Left Tilt 15°	1 Mbps	0.691
2437	6 (Mid)	802.11b	18.48	18.50	Standard	Right Tilt 15°	1 Mbps	0.768
ANSI/ IEEE C95.1 - 1992– Safety Limit						Head		
Spatial Peak						1.6 W/kg (mW/g)		
Uncontrolled Exposure/ General Population						Averaged over 1 gram		

NOTES:

- 1 The test data reported are the worst-case SAR value with the antenna-head position set in a typical configuration. Test procedures used are according to FCC/OET Bulletin 65, Supplement C [July 2001].
- 2 All modes of operation were investigated and the worst-case are reported.
- 3 Measured Depth of Simulating Tissue is 15.0 cm ± 0.2 cm.
- 4 Tissue parameters and temperatures are listed on the SAR plot.
- 5 Battery Type Standard Extended Slim
Batteries are fully charged for all readings.
- 6 Test Signal Call Mode Manual Test cord Base Station Simulator
- 7 Justification for reduced test configurations: per FCC/OET Supplement C (July, 2001), if the SAR measured at the middle channel for each test configuration (Left, right, cheek/touch, tilt/ear, extended and retracted) is at least 3.0 dB lower than the SAR limit, testing at the high and low channels is optional for such test configuration(s).

13.11 Measurement Results (GSM850 Body SAR)

Frequency		Modulation	Conducted Power (dBm)		Configuration	Phantom Position	Antenna Type	SAR(mW/g)
MHz	Channel		Begin	End				
824.2	128 (Low)	GPRS 2Tx	32.60	32.60	Rear	2.0 cm without Holster	Intenna	1.02
836.6	190 (Mid)	GPRS 2Tx	32.54	32.61	Rear	2.0 cm without Holster	Intenna	0.941
848.8	251 (High)	GPRS 2Tx	32.52	32.53	Rear	2.0 cm without Holster	Intenna	0.851
836.6	190 (Mid)	GPRS 1Tx	32.57	32.51	Rear	2.0 cm without Holster	Intenna	0.473
836.6	190 (Mid)	GSM850	32.57	32.43	Rear	2.0 cm without Holster	Intenna	0.462
ANSI/ IEEE C95.1 - 1992– Safety Limit Spatial Peak Uncontrolled Exposure/ General Population						Body 1.6 W/kg (mW/g) Averaged over 1 gram		

NOTES:

- The test data reported are the worst-case SAR value with the antenna-head position set in a typical configuration. Test procedures used are according to FCC/OET Bulletin 65, Supplement C [July 2001].
- All modes of operation were investigated and the worst-case are reported.
- Measured Depth of Simulating Tissue is 15.0 cm ± 0.2 cm.
- Tissue parameters and temperatures are listed on the SAR plot.
- Battery Type Standard Extended Slim
Batteries are fully charged for all readings.
- Test Signal Call Mode Manual Test cord Base Station Simulator
- Both side of the phone were tested and the worst-case side is reported.
- Test Configuration With Holster Without Holster
- HEADSET was connected.
- Justification for reduced test configurations: per FCC/OET Supplement C (July, 2001), if the SAR measured at the middle channel for each test configuration (Left, right, cheek/touch, tilt/ear, extended and retracted) is at least 3.0 dB lower than the SAR limit, testing at the high and low channels is optional for such test configuration(s).

13.12 Measurement Results (GSM1900 Body SAR)

Frequency		Modulation	Conducted Power (dBm)		Configuration	Phantom Position	Antenna Type	SAR(mW/g)
MHz	Channel		Begin	End				
1 880.0	661 (Mid)	GPRS 2Tx	30.25	30.21	Rear	2.0 cm without Holster	Intenna	0.585
1 880.0	661 (Mid)	GPRS 1Tx	30.28	30.37	Rear	2.0 cm without Holster	Intenna	0.285
1 880.0	661 (Mid)	GSM1900	30.28	30.28	Rear	2.0 cm without Holster	Intenna	0.287
ANSI/ IEEE C95.1 - 1992– Safety Limit						Body		
Spatial Peak						1.6 W/kg (mW/g)		
Uncontrolled Exposure/ General Population						<small>Averaged over 1 gram</small>		

NOTES:

- 1 The test data reported are the worst-case SAR value with the antenna-head position set in a typical configuration. Test procedures used are according to FCC/OET Bulletin 65, Supplement C [July 2001].
- 2 All modes of operation were investigated and the worst-case are reported.
- 3 Measured Depth of Simulating Tissue is 15.0 cm ± 0.2 cm.
- 4 Tissue parameters and temperatures are listed on the SAR plot.
- 5 Battery Type Standard Extended Slim
Batteries are fully charged for all readings.
- 6 Test Signal Call Mode Manual Test cord Base Station Simulator
- 7 Both side of the phone were tested and the worst-case side is reported.
- 8 Test Configuration With Holster Without Holster
- 9 HEADSET was connected.
- 10 Justification for reduced test configurations: per FCC/OET Supplement C (July, 2001), if the SAR measured at the middle channel for each test configuration (Left, right, cheek/touch, tilt/ear, extended and retracted) is at least 3.0 dB lower than the SAR limit, testing at the high and low channels is optional for such test configuration(s).

13.13 Measurement Results (WCDMA850 Body SAR)

Frequency		Modulation	Conducted Power (dBm)		Configuration	Phantom Position	Antenna Type	SAR(mW/g)
MHz	Channel		Begin	End				
836.6	4183 (Mid)	WCDMA850	22.76	22.87	Rear	2.0 cm without Holster	Intenna	0.583
ANSI/ IEEE C95.1 - 1992– Safety Limit Spatial Peak Uncontrolled Exposure/ General Population						Body 1.6 W/kg (mW/g) Averaged over 1 gram		

- 1 The test data reported are the worst-case SAR value with the antenna-head position set in a typical configuration. Test procedures used are according to FCC/OET Bulletin 65, Supplement C [July 2001].
- 2 All modes of operation were investigated and the worst-case are reported.
- 3 Measured Depth of Simulating Tissue is 15.0 cm ± 0.2 cm.
- 4 Tissue parameters and temperatures are listed on the SAR plot.
- 5 Battery Type Standard Extended Slim
Batteries are fully charged for all readings.
- 6 Test Signal Call Mode Manual Test cord Base Station Simulator
- 7 Both side of the phone were tested and the worst-case side is reported.
- 8 HEADSET was connected.
- 9 Test Configuration With Holster Without Holster
- 10 Justification for reduced test configurations: per FCC/OET Supplement C (July, 2001), if the SAR measured at the middle channel for each test configuration (Left, right, cheek/touch, tilt/ear, extended and retracted) is at least 3.0 dB lower than the SAR limit, testing at the high and low channels is optional for such test configuration(s).
- 11 WCDMA Mode was tested under RMC 12.2 kbps and HSDPA Inactive.

13.14 Measurement Results (WCDMA1900 Body SAR)

Frequency		Modulation	Conducted Power (dBm)		Configuration	Phantom Position	Antenna Type	SAR(mW/g)
MHz	Channel		Begin	End				
1 880.0	9400 (Mid)	WCDMA1900	22.87	23.00	Rear	2.0 cm without Holster	Intenna	0.580
ANSI/ IEEE C95.1 - 1992- Safety Limit Spatial Peak Uncontrolled Exposure/ General Population						Body 1.6 W/kg (mW/g) Averaged over 1 gram		

- 1 The test data reported are the worst-case SAR value with the antenna-head position set in a typical configuration. Test procedures used are according to FCC/OET Bulletin 65, Supplement C [July 2001].
- 2 All modes of operation were investigated and the worst-case are reported.
- 3 Measured Depth of Simulating Tissue is 15.0 cm ± 0.2 cm.
- 4 Tissue parameters and temperatures are listed on the SAR plot.
- 5 Battery Type Standard Extended Slim
Batteries are fully charged for all readings.
- 6 Test Signal Call Mode Manual Test cord Base Station Simulator
- 7 Both side of the phone were tested and the worst-case side is reported.
- 8 HEADSET was connected.
- 9 Test Configuration With Holster Without Holster
- 10 Justification for reduced test configurations: per FCC/OET Supplement C (July, 2001), if the SAR measured at the middle channel for each test configuration (Left, right, cheek/touch, tilt/ear, extended and retracted) is at least 3.0 dB lower than the SAR limit, testing at the high and low channels is optional for such test configuration(s).
- 11 WCDMA Mode was tested under RMC 12.2 kbps and HSDPA Inactive.

13.15 Measurement Results (802.11b/g/n Body SAR)

Frequency		Modulation	Conducted Power (dBm)		Configuration	Separation Distance	Data Rate	SAR(mW/g)
MHz	Channel		Begin	End				
2412	1 (Low)	802.11b	18.53	18.54	Rear	2.0 cm	1 Mbps	0.290
2437	6 (Mid)	802.11b	18.48	18.51	Rear	2.0 cm	1 Mbps	0.235
2462	11 (High)	802.11b	18.59	18.61	Rear	2.0 cm	1 Mbps	0.216
ANSI/ IEEE C95.1 1992 – Safety Limit						Body		
Spatial Peak						1.6 W/kg (mW/g)		
Uncontrolled Exposure/ General Population						<small>Averaged over 1 gram</small>		

NOTES:

- 1 The test data reported are the worst-case SAR value with the antenna-head position set in a typical configuration. Test procedures used are according to FCC/OET Bulletin 65, Supplement C [July 2001].
- 2 All modes of operation were investigated and the worst-case are reported.
- 3 Measured Depth of Simulating Tissue is 15.0 cm ± 0.2 cm.
- 4 Tissue parameters and temperatures are listed on the SAR plot.
- 5 Battery Type Standard Extended Slim
Batteries are fully charged for all readings.
- 6 Test Signal Call Mode Manual Test code Base Station Simulator

13.16 Measurement Results (GSM850 Hotspot Body SAR)

Frequency		Modulation	Conducted Power (dBm)		Configuration	Separation Distance	SAR(mW/g)
MHz	Channel		Begin	End			
836.6	190 (Mid)	GPRS 2Tx	30.57	30.45	Front	1.0 cm	0.491
824.2	128 (Low)	GPRS 2Tx	30.55	30.56	Rear	1.0 cm	1.24
836.6	190 (Mid)	GPRS 2Tx	30.57	30.53	Rear	1.0 cm	1.1
848.8	251 (High)	GPRS 2Tx	30.58	30.61	Rear	1.0 cm	1.03
836.6	190 (Mid)	GPRS 2Tx	30.57	30.61	Edge A	1.0 cm	0.646
836.6	190 (Mid)	GPRS 2Tx	30.57	30.60	Edge B	1.0 cm	0.431
836.6	190 (Mid)	GPRS 2Tx	30.57	30.76	Edge C	1.0 cm	0.620
ANSI/ IEEE C95.1 - 2005– Safety Limit Spatial Peak Uncontrolled Exposure/ General Population						Body 1.6 W/kg (mW/g) Averaged over 1 gram	

NOTES:

- 1 The test data reported are the worst-case SAR value with the antenna-head position set in a typical configuration. Test procedures used are according to FCC/OET Bulletin 65, Supplement C [July 2001].
- 2 All modes of operation were investigated and the worst-case are reported.
- 3 Measured Depth of Simulating Tissue is 15.0 cm ± 0.2 cm.
- 4 Tissue parameters and temperatures are listed on the SAR plot.
- 5 Battery Type Standard Extended Slim
Batteries are fully charged for all readings.
- 6 Test Signal Call Mode Manual Test cord Base Station Simulator
- 7 Test Configuration With Holster Without Holster
- 8 Justification for reduced test configurations: per FCC/OET Supplement C (July, 2001), if the SAR measured at the middle channel for each test configuration (Left, right, cheek/touch, tilt/ear, extended and retracted) is at least 3.0 dB lower than the SAR limit, testing at the high and low channels is optional for such test configuration(s).

13.17 Measurement Results (GSM1900 Hotspot Body SAR)

Frequency		Modulation	Conducted Power (dBm)		Configuration	Separation Distance	SAR(mW/g)
MHz	Channel		Begin	End			
1 880.0	661 (Mid)	GPRS 2Tx	28.06	28.25	Front	1.0 cm	0.151
1 850.2	512 (Low)	GPRS 2Tx	27.97	27.93	Rear	1.0 cm	0.645
1 880.0	661 (Mid)	GPRS 2Tx	28.06	28.02	Rear	1.0 cm	0.878
1 909.8	810 (High)	GPRS 2Tx	28.09	27.91	Rear	1.0 cm	0.996
1 880.0	661 (Mid)	GPRS 2Tx	28.06	28.03	Edge A	1.0 cm	0.12
1 880.0	661 (Mid)	GPRS 2Tx	28.06	28.25	Edge B	1.0 cm	0.112
1 850.2	512 (Low)	GPRS 2Tx	27.97	28.00	Edge C	1.0 cm	0.748
1 880.0	661 (Mid)	GPRS 2Tx	28.06	28.16	Edge C	1.0 cm	0.894
1 909.8	810 (High)	GPRS 2Tx	28.09	28.10	Edge C	1.0 cm	0.941
ANSI/ IEEE C95.1 - 2005– Safety Limit Spatial Peak Uncontrolled Exposure/ General Population						Body 1.6 W/kg (mW/g) Averaged over 1 gram	

NOTES:

- 1 The test data reported are the worst-case SAR value with the antenna-head position set in a typical configuration. Test procedures used are according to FCC/OET Bulletin 65, Supplement C [July 2001].
- 2 All modes of operation were investigated and the worst-case are reported.
- 3 Measured Depth of Simulating Tissue is 15.0 cm ± 0.2 cm.
- 4 Tissue parameters and temperatures are listed on the SAR plot.
- 5 Battery Type Standard Extended Slim
Batteries are fully charged for all readings.
- 6 Test Signal Call Mode Manual Test cord Base Station Simulator
- 7 Test Configuration With Holster Without Holster
- 8 Justification for reduced test configurations: per FCC/OET Supplement C (July, 2001), if the SAR measured at the middle channel for each test configuration (Left, right, cheek/touch, tilt/ear, extended and retracted) is at least 3.0 dB lower than the SAR limit, testing at the high and low channels is optional for such test configuration(s).

13.18 Measurement Results (WCDMA850 Hotspot Body SAR)

Frequency		Modulation	Conducted Power (dBm)		Configuration	Separation Distance	SAR(mW/g)
MHz	Channel		Begin	End			
836.6	4183 (Mid)	WCDMA850	21.75	21.90	Front	1.0 cm	0.333
836.6	4183 (Mid)	WCDMA850	21.75	21.66	Rear	1.0 cm	0.617
836.6	4183 (Mid)	WCDMA850	21.75	21.79	Edge A	1.0 cm	0.426
836.6	4183 (Mid)	WCDMA850	21.75	21.87	Edge B	1.0 cm	0.318
836.6	4183 (Mid)	WCDMA850	21.75	21.89	Edge C	1.0 cm	0.251
ANSI/ IEEE C95.1 - 2005– Safety Limit Spatial Peak Uncontrolled Exposure/ General Population						Body 1.6 W/kg (mW/g) Averaged over 1 gram	

The test data reported are the worst-case SAR value with the antenna-head position set in a typical configuration. Test procedures used are according to FCC/OET Bulletin 65, Supplement C [July 2001].

- 2 All modes of operation were investigated and the worst-case are reported.
- 3 Measured Depth of Simulating Tissue is 15.0 cm ± 0.2 cm.
- 4 Tissue parameters and temperatures are listed on the SAR plot.
- 5 Battery Type Standard Extended Slim
Batteries are fully charged for all readings.
- 6 Test Signal Call Mode Manual Test cord Base Station Simulator
- 7 Both side of the phone were tested and the worst-case side is reported.
- 8 Test Configuration With Holster Without Holster
- 9 Justification for reduced test configurations: per FCC/OET Supplement C (July, 2001), if the SAR measured at the middle channel for each test configuration (Left, right, cheek/touch, tilt/ear, extended and retracted) is at least 3.0 dB lower than the SAR limit, testing at the high and low channels is optional for such test configuration(s).
- 10 WCDMA Mode was tested under RMC 12.2 kbps and HSPA Inactive.

13.19 Measurement Results (WCDMA1900 Hotspot Body SAR)

Frequency		Modulation	Conducted Power (dBm)		Configuration	Separation Distance	SAR(mW/g)
MHz	Channel		Begin	End			
1 880.0	9400 (Mid)	WCDMA1900	21.49	21.63	Front	1.0 cm	0.291
1 852.4	9262 (Low)	WCDMA1900	21.47	21.51	Rear	1.0 cm	0.967
1 880.0	9400 (Mid)	WCDMA1900	21.49	21.55	Rear	1.0 cm	1.16
1 907.6	9538 (High)	WCDMA1900	21.42	21.46	Rear	1.0 cm	1.07
1 880.0	9400 (Mid)	WCDMA1900	21.49	21.51	Edge A	1.0 cm	0.166
1 880.0	9400 (Mid)	WCDMA1900	21.49	21.59	Edge B	1.0 cm	0.168
1 852.4	9262 (Low)	WCDMA1900	21.47	21.54	Edge C	1.0 cm	1.07
1 880.0	9400 (Mid)	WCDMA1900	21.49	21.55	Edge C	1.0 cm	1.14
1 907.6	9538 (High)	WCDMA1900	21.42	21.50	Edge C	1.0 cm	1.03
ANSI/ IEEE C95.1 - 2005– Safety Limit Spatial Peak Uncontrolled Exposure/ General Population						Body 1.6 W/kg (mW/g) Averaged over 1 gram	

- 1 The test data reported are the worst-case SAR value with the antenna-head position set in a typical configuration. Test procedures used are according to FCC/OET Bulletin 65, Supplement C [July 2001].
- 2 All modes of operation were investigated and the worst-case are reported.
- 3 Measured Depth of Simulating Tissue is 15.0 cm ± 0.2 cm.
- 4 Tissue parameters and temperatures are listed on the SAR plot.
- 5 Battery Type Standard Extended Slim
Batteries are fully charged for all readings.
- 6 Test Signal Call Mode Manual Test cord Base Station Simulator
- 7 Test Configuration With Holster Without Holster
- 8 Justification for reduced test configurations: per FCC/OET Supplement C (July, 2001), if the SAR measured at the middle channel for each test configuration (Left, right, cheek/touch, tilt/ear, extended and retracted) is at least 3.0 dB lower than the SAR limit, testing at the high and low channels is optional for such test configuration(s).
- 9 WCDMA Mode was tested under RMC 12.2 kbps and HSPA Inactive.

13.20 Measurement Results (802.11b/g/n Module Body SAR)

Frequency		Modulation	Conducted Power (dBm)		Configuration	Separation Distance	Data Rate	SAR(mW/g)
MHz	Channel		Begin	End				
2 462	11 (High)	802.11b	18.59	18.49	Front	1.0 cm	1 Mbps	0.074
2 462	11 (High)	802.11b	18.59	18.60	Rear	1.0 cm	1 Mbps	0.343
2 462	11 (High)	802.11b	18.59	18.61	Edge A	1.0 cm	1 Mbps	0.034
2 462	11 (High)	802.11b	18.59	13.64	Edge D	1.0 cm	1 Mbps	0.187
ANSI/ IEEE C95.1 1992 – Safety Limit Spatial Peak Uncontrolled Exposure/ General Population						Body 1.6 W/kg (mW/g) <small>Averaged over 1 gram</small>		

NOTES:

- The test data reported are the worst-case SAR value with the antenna-head position set in a typical configuration. Test procedures used are according to FCC/OET Bulletin 65, Supplement C [July 2001].
- All modes of operation were investigated and the worst-case are reported.
- Measured Depth of Simulating Tissue is 15.0 cm ± 0.2 cm.
- Tissue parameters and temperatures are listed on the SAR plot.
- Battery Type Standard Extended Slim
Batteries are fully charged for all readings.
- Test Signal Call Mode Manual Test code Base Station Simulator
- IEEE 802.11g(including 802.11n) SAR testing is required when the conducted powers are equal to or greater than 0.25 dB Than the conducted powers in IEEE 802.11b.

14. CONCLUSION

The SAR measurement indicates that the EUT complies with the RF radiation exposure limits of the ANSI/IEEE C95.1 2005.

These measurements are taken to simulate the RF effects exposure under worst-case conditions. Precise laboratory measures were taken to assure repeatability of the tests.

15. REFERENCES

- [1] Federal Communications Commission, OET Bulletin 65 (Edition 97-01), Supplement C (Edition 01-01), Evaluating Compliance with FCC Guidelines for Human Exposure to Radio frequency Electromagnetic Fields, July 2001.
- [2] IEEE Standards Coordinating Committee 34 – IEEE Std. 1528-2003, IEEE Recommended Practice for Determining the Peak Spatial-Average Specific Absorption Rate (SAR) in the Human Body from Wireless Communications Devices.
- [3] Federal Communications Commission, ET Docket 93-62, Guidelines for Evaluating the Environmental Effects of Radio frequency Radiation, Aug. 1996.
- [4] ANSI/IEEE C95.1 - 1991, American National Standard safety levels with respect to human exposure to radio frequency electromagnetic fields, 300 kHz to 100 GHz, New York: IEEE, Aug. 1992
- [5] ANSI/IEEE C95.3 - 1991, IEEE Recommended Practice for the Measurement of Potentially Hazardous Electromagnetic Fields - RF and Microwave, New York: IEEE, 1992.
- [6] NCRP, National Council on Radiation Protection and Measurements, Biological Effects and Exposure Criteria for Radio Frequency Electromagnetic Fields, NCRP Report No. 86, 1986. Reprinted Feb. 1995.
- [7] T. Schmid, O. Egger, N. Kuster, Automated E-field scanning system for dosimetric assessments, IEEE Transaction on Microwave Theory and Techniques, vol. 44, Jan. 1996, pp. 105-113.
- [8] K. Pokovic, T. Schmid, N. Kuster, Robust setup for precise calibration of E-field probes in tissue simulating liquids at mobile communications frequencies, ICECOM97, Oct. 1997, pp. 120-124.
- [9] K. Pokovic, T. Schmid, and N. Kuster, E-field Probe with improved isotropy in brain simulating liquids, Proceedings of the ELMAR, Zadar, Croatia, June 23-25, 1996, pp. 172-175.
- [10] Schmid & Partner Engineering AG, Application Note: Data Storage and Evaluation, June 1998, p2.
- [11] V. Hombach, K. Meier, M. Burkhardt, E. Kuhn, N. Kuster, The Dependence of EM Energy Absorption upon Human Head Modeling at 900 MHz, IEEE Transaction on Microwave Theory and Techniques, vol. 44 no. 10, Oct. 1996, pp. 1865-1873.
- [12] N. Kuster and Q. Balzano, Energy absorption mechanism by biological bodies in the near field of dipole antennas above 300 MHz, IEEE Transaction on Vehicular Technology, vol. 41, no. 1, Feb. 1992, pp. 17-23.
- [13] G. Hartsgrrove, A. Kraszewski, A. Surowiec, Simulated Biological Materials for Electromagnetic Radiation Absorption Studies, University of Ottawa, Bioelectromagnetics, Canada: 1987, pp. 29-36.
- [14] Q. Balzano, O. Garay, T. Manning Jr., Electromagnetic Energy Exposure of Simulated Users of Portable Cellular Telephones, IEEE Transactions on Vehicular Technology, vol. 44, no.3, Aug. 1995.
- [15] W. Gander, Computer mathematick, Birkhaeuser, Basel, 1992.
- [16] W.H. Press, S.A. Teukolsky, W.T. Vetterling, and B.P. Flannery, Numerical Recipes in C, The Art of Scientific Computing, Second edition, Cambridge University Press, 1992.
- [17] Federal Communications Commission, OET Bulletin 65, Evaluating Compliance with FCC Guidelines for Human Exposure to Radiofrequency Electromagnetic Fields. Supplement C, Dec. 1997.
- [18] N. Kuster, R. Kastle, T. Schmid, Dosimetric evaluation of mobile communications equipment with known precision, IEEE Transaction on Communications, vol. E80-B, no. 5, May 1997, pp. 645-652.
- [19] CENELEC CLC/SC111B, European Prestandard (prENV 50166-2), Human Exposure to Electromagnetic Fields High-frequency: 10 kHz-300 GHz, Jan. 1995.
- [20] Prof. Dr. Niels Kuster, ETH, Eidgenössische Technische Hochschule Zürich, Dosimetric Evaluation of the Cellular Phone.
- [21] SAR Evaluation of Handsets with Multiple Transmitters and Antennas #648474.
- [22] SAR Measurement Procedure for 802.11 a/b/g Transmitters #KDB 248227.

Attachment 1. – SAR Test Plots

Test Laboratory: HCT CO., LTD
EUT Type: GSM/WCDMA Phone with Bluetooth & WLAN
GPRS Class10 and GPRS mode class B(GPRS and GSM, but not simultaneously)
Liquid Temperature: 21.4 °C
Ambient Temperature: 21.6 °C
Test Date: Nov.15, 2010

DUT: P8000; Type: Bar; Serial: #1

Communication System: GSM 850; Frequency: 836.6 MHz; Duty Cycle: 1:8.3
Medium parameters used (interpolated): $f = 836.6$ MHz; $\sigma = 0.891$ mho/m; $\epsilon_r = 42.1$; $\rho = 1000$ kg/m³
Phantom section: Left Section ; Measurement SW: DASY4, V4.7 Build 80; Postprocessing SW: SEMCAD, V1.8
Build 184

DASY4 Configuration:
- Probe: ES3DV3 - SN3161; ConvF(5.96, 5.96, 5.96); Calibrated: 2010-03-22
- Sensor-Surface: 4mm (Mechanical Surface Detection)
- Electronics: DAE3 Sn446; Calibrated: 2010-09-21
- Phantom: 835/900 Phantom ; Type: SAM

Left touch 190/Area Scan (51x91x1): Measurement grid: dx=15mm, dy=15mm

[Info: Interpolated medium parameters used for SAR evaluation.](#)

Maximum value of SAR (interpolated) = 0.426 mW/g

Left touch 190/Zoom Scan (5x5x7)/Cube 0: Measurement grid: dx=8mm, dy=8mm, dz=5mm

Reference Value = 8.99 V/m; Power Drift = -0.139 dB

Peak SAR (extrapolated) = 0.509 W/kg

SAR(1 g) = 0.381 mW/g; SAR(10 g) = 0.276 mW/g

Maximum value of SAR (measured) = 0.404 mW/g

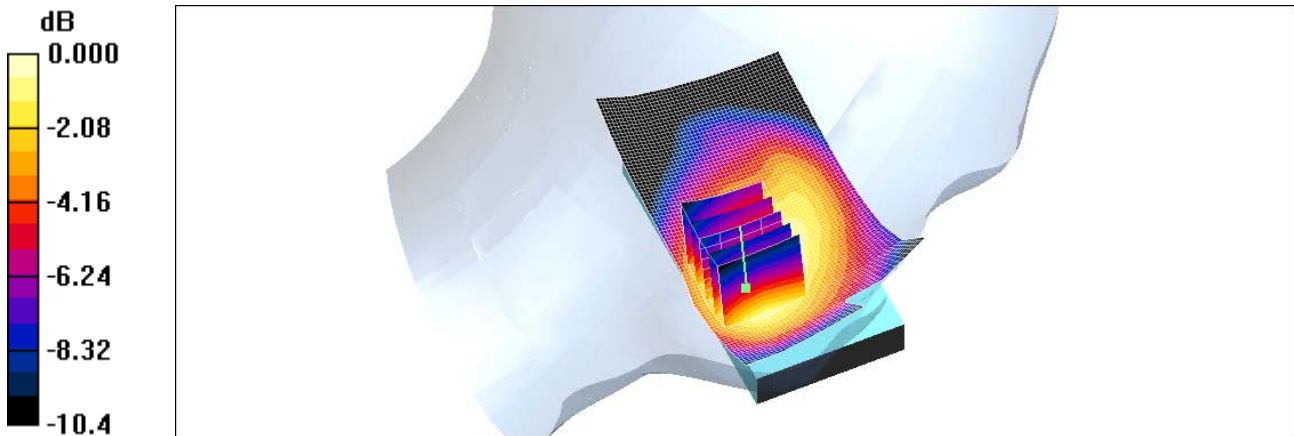

0 dB = 0.404mW/g

Test Laboratory: HCT CO., LTD
EUT Type: GSM/WCDMA Phone with Bluetooth & WLAN
GPRS Class10 and GPRS mode class B(GPRS and GSM, but not simultaneously)
Liquid Temperature: 21.4 °C
Ambient Temperature: 21.6 °C
Test Date: Nov.15, 2010

DUT: P8000; Type: Bar; Serial: #1

Communication System: GSM 850; Frequency: 836.6 MHz; Duty Cycle: 1:8.3
Medium parameters used (interpolated): $f = 836.6$ MHz; $\sigma = 0.891$ mho/m; $\epsilon_r = 42.1$; $\rho = 1000$ kg/m³
Phantom section: Right Section ; Measurement SW: DASY4, V4.7 Build 80; Postprocessing SW: SEMCAD, V1.8 Build 184

DASY4 Configuration:

- Probe: ES3DV3 - SN3161; ConvF(5.96, 5.96, 5.96); Calibrated: 2010-03-22
- Sensor-Surface: 4mm (Mechanical Surface Detection)
- Electronics: DAE3 Sn446; Calibrated: 2010-09-21
- Phantom: 835/900 Phantom ; Type: SAM

Right touch 190/Area Scan (51x91x1): Measurement grid: dx=15mm, dy=15mm

[Info: Interpolated medium parameters used for SAR evaluation.](#)

Maximum value of SAR (interpolated) = 0.375 mW/g

Right touch 190/Zoom Scan (5x5x7)/Cube 0: Measurement grid: dx=8mm, dy=8mm, dz=5mm

Reference Value = 9.13 V/m; Power Drift = -0.141 dB

Peak SAR (extrapolated) = 0.441 W/kg

SAR(1 g) = 0.354 mW/g; SAR(10 g) = 0.269 mW/g

[Info: Interpolated medium parameters used for SAR evaluation.](#)

Maximum value of SAR (measured) = 0.369 mW/g

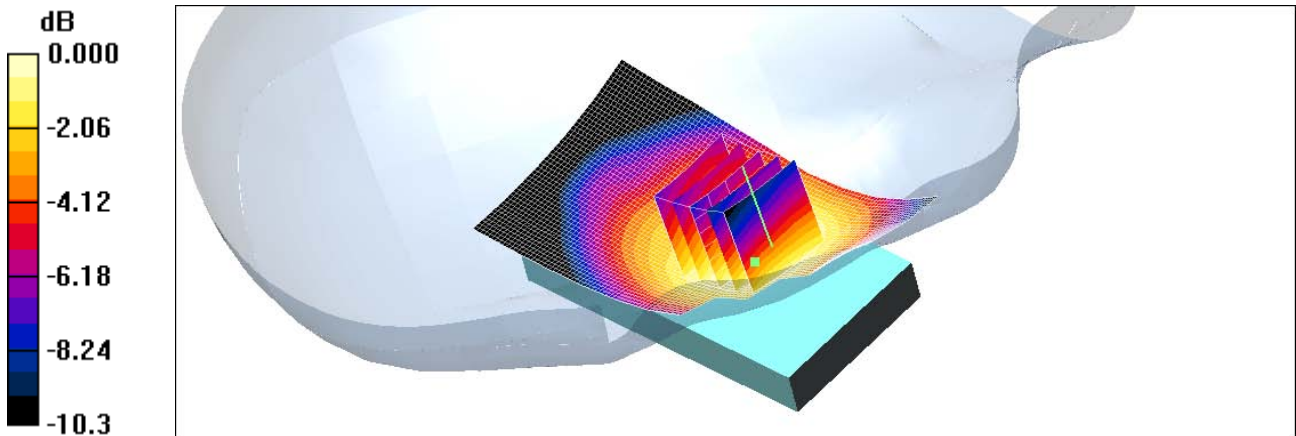

0 dB = 0.369mW/g

Test Laboratory: HCT CO., LTD
EUT Type: GSM/WCDMA Phone with Bluetooth & WLAN
GPRS Class10 and GPRS mode class B(GPRS and GSM, but not simultaneously)
Liquid Temperature: 21.4 °C
Ambient Temperature: 21.6 °C
Test Date: Nov.15, 2010

DUT: P8000; Type: Bar; Serial: #1

Communication System: GSM 850; Frequency: 836.6 MHz; Duty Cycle: 1:8.3
Medium parameters used (interpolated): $f = 836.6$ MHz; $\sigma = 0.891$ mho/m; $\epsilon_r = 42.1$; $\rho = 1000$ kg/m³
Phantom section: Left Section ; Measurement SW: DASY4, V4.7 Build 80; Postprocessing SW: SEMCAD, V1.8 Build 184

DASY4 Configuration:

- Probe: ES3DV3 - SN3161; ConvF(5.96, 5.96, 5.96); Calibrated: 2010-03-22
- Sensor-Surface: 4mm (Mechanical Surface Detection)
- Electronics: DAE3 Sn446; Calibrated: 2010-09-21
- Phantom: 835/900 Phantom ; Type: SAM

Left tilt 190/Area Scan (51x91x1): Measurement grid: dx=15mm, dy=15mm

[Info: Interpolated medium parameters used for SAR evaluation.](#)

Maximum value of SAR (interpolated) = 0.297 mW/g

Left tilt 190/Zoom Scan (5x5x7)/Cube 0: Measurement grid: dx=8mm, dy=8mm, dz=5mm

Reference Value = 14.6 V/m; Power Drift = 0.028 dB

Peak SAR (extrapolated) = 0.358 W/kg

SAR(1 g) = 0.291 mW/g; SAR(10 g) = 0.221 mW/g

[Info: Interpolated medium parameters used for SAR evaluation.](#)

Maximum value of SAR (measured) = 0.304 mW/g

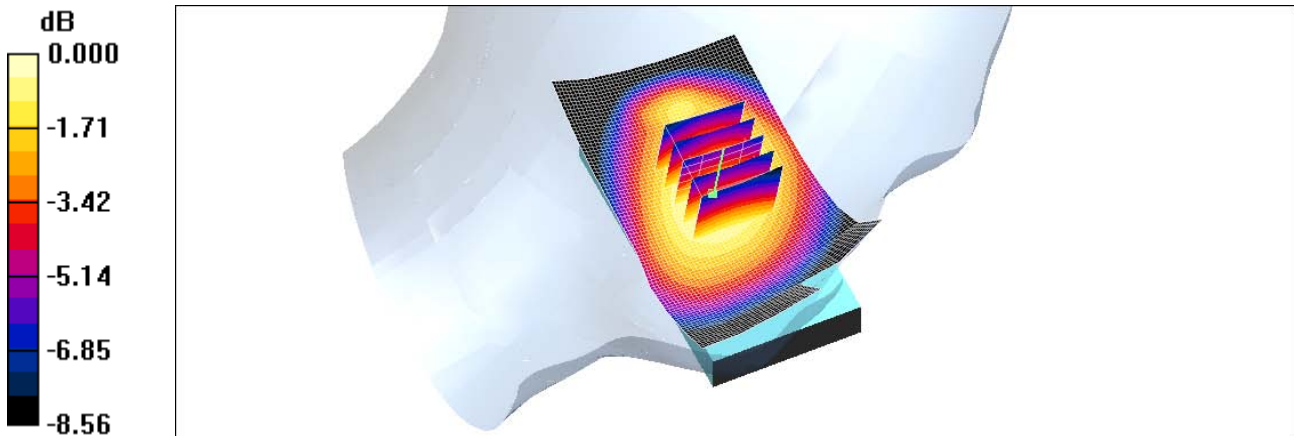

0 dB = 0.304mW/g

Test Laboratory: HCT CO., LTD
EUT Type: GSM/WCDMA Phone with Bluetooth & WLAN
GPRS Class10 and GPRS mode class B(GPRS and GSM, but not simultaneously)
Liquid Temperature: 21.4 °C
Ambient Temperature: 21.6 °C
Test Date: Nov.15, 2010

DUT: P8000; Type: Bar; Serial: #1

Communication System: GSM 850; Frequency: 836.6 MHz; Duty Cycle: 1:8.3
Medium parameters used (interpolated): $f = 836.6$ MHz; $\sigma = 0.891$ mho/m; $\epsilon_r = 42.1$; $\rho = 1000$ kg/m³
Phantom section: Right Section ; Measurement SW: DASY4, V4.7 Build 80; Postprocessing SW: SEMCAD, V1.8 Build 184

DASY4 Configuration:

- Probe: ES3DV3 - SN3161; ConvF(5.96, 5.96, 5.96); Calibrated: 2010-03-22
- Sensor-Surface: 4mm (Mechanical Surface Detection)
- Electronics: DAE3 Sn446; Calibrated: 2010-09-21
- Phantom: 835/900 Phantom ; Type: SAM

Right tilt 190/Area Scan (51x91x1): Measurement grid: dx=15mm, dy=15mm

[Info: Interpolated medium parameters used for SAR evaluation.](#)

Maximum value of SAR (interpolated) = 0.276 mW/g

Right tilt 190/Zoom Scan (5x5x7)/Cube 0: Measurement grid: dx=8mm, dy=8mm, dz=5mm

Reference Value = 14.1 V/m; Power Drift = 0.010 dB

Peak SAR (extrapolated) = 0.333 W/kg

SAR(1 g) = 0.268 mW/g; SAR(10 g) = 0.206 mW/g

[Info: Interpolated medium parameters used for SAR evaluation.](#)

Maximum value of SAR (measured) = 0.280 mW/g

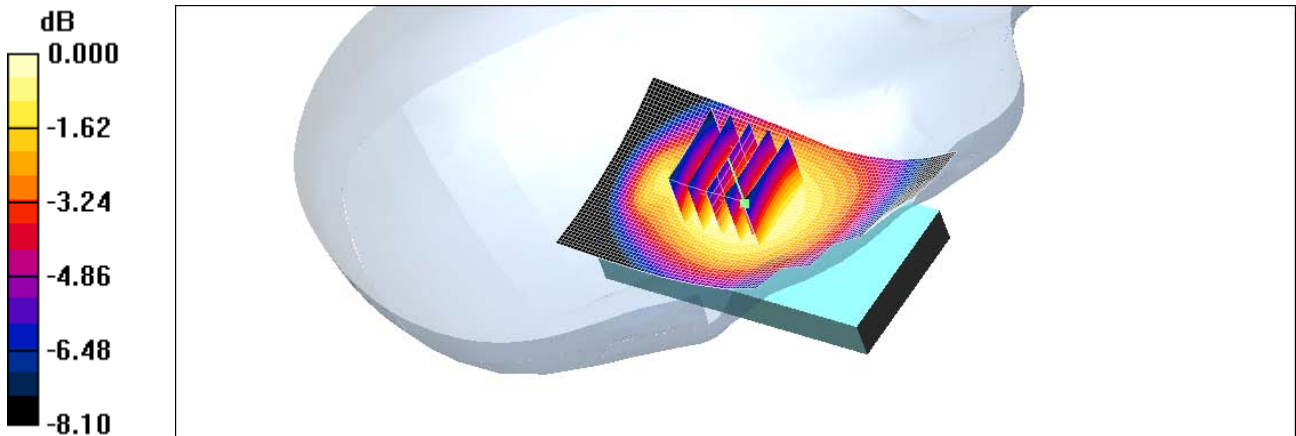

0 dB = 0.280mW/g

Test Laboratory: HCT CO., LTD
EUT Type: GSM/WCDMA Phone with Bluetooth & WLAN
GPRS Class10 and GPRS mode class B(GPRS and GSM, but not simultaneously)
Liquid Temperature: 21.1 °C
Ambient Temperature: 21.3 °C
Test Date: Nov.16, 2010

DUT: P8000; Type: Bar; Serial: #1

Communication System: GSM 1900; Frequency: 1880 MHz; Duty Cycle: 1:8.3
Medium parameters used: $f = 1880 \text{ MHz}$; $\sigma = 1.38 \text{ mho/m}$; $\epsilon_r = 41$; $\rho = 1000 \text{ kg/m}^3$
Phantom section: Left Section ; Measurement SW: DASY4, V4.7 Build 80; Postprocessing SW: SEMCAD, V1.8 Build 184

DASY4 Configuration:

- Probe: ES3DV3 - SN3161; ConvF(4.79, 4.79, 4.79); Calibrated: 2010-03-22
- Sensor-Surface: 4mm (Mechanical Surface Detection)
- Electronics: DAE3 Sn446; Calibrated: 2010-09-21
- Phantom: 1800/1900 Phantom; Type: SAM

Left touch 661/Area Scan (51x91x1): Measurement grid: $dx=15\text{mm}$, $dy=15\text{mm}$
Maximum value of SAR (interpolated) = 0.646 mW/g

Left touch 661/Zoom Scan (5x5x7)/Cube 0: Measurement grid: $dx=8\text{mm}$, $dy=8\text{mm}$, $dz=5\text{mm}$
Reference Value = 11.0 V/m; Power Drift = -0.068 dB
Peak SAR (extrapolated) = 0.880 W/kg
SAR(1 g) = 0.567 mW/g; SAR(10 g) = 0.327 mW/g
Maximum value of SAR (measured) = 0.618 mW/g

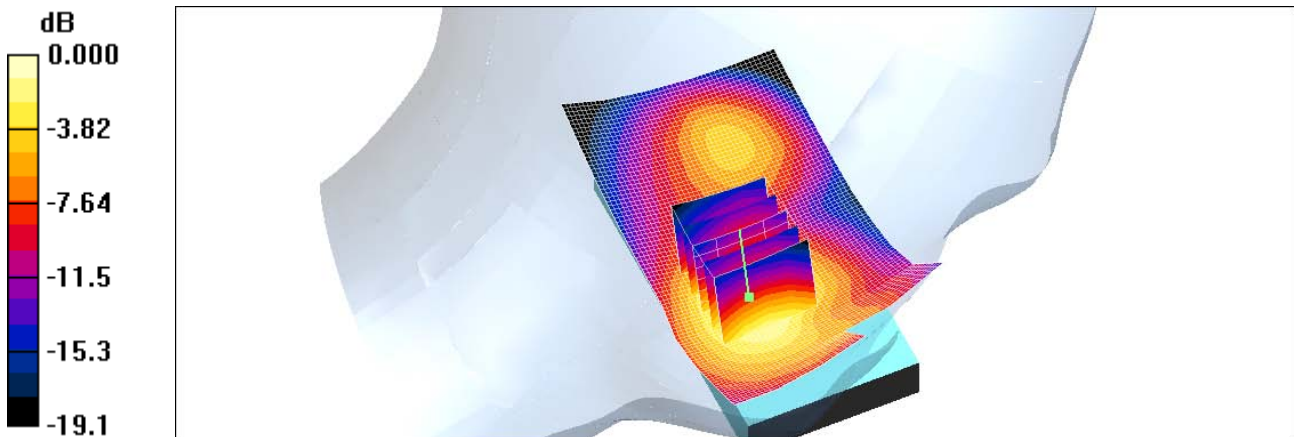

0 dB = 0.618mW/g

Test Laboratory: HCT CO., LTD
EUT Type: GSM/WCDMA Phone with Bluetooth & WLAN
GPRS Class10 and GPRS mode class B(GPRS and GSM, but not simultaneously)
Liquid Temperature: 21.1 °C
Ambient Temperature: 21.3 °C
Test Date: Nov.16, 2010

DUT: P8000; Type: Bar; Serial: #1

Communication System: GSM 1900; Frequency: 1880 MHz; Duty Cycle: 1:8.3
Medium parameters used: $f = 1880 \text{ MHz}$; $\sigma = 1.38 \text{ mho/m}$; $\epsilon_r = 41$; $\rho = 1000 \text{ kg/m}^3$
Phantom section: Right Section ; Measurement SW: DASY4, V4.7 Build 80; Postprocessing SW: SEMCAD, V1.8 Build 184

DASY4 Configuration:

- Probe: ES3DV3 - SN3161; ConvF(4.79, 4.79, 4.79); Calibrated: 2010-03-22
- Sensor-Surface: 4mm (Mechanical Surface Detection)
- Electronics: DAE3 Sn446; Calibrated: 2010-09-21
- Phantom: 1800/1900 Phantom; Type: SAM

Right touch 661/Area Scan (51x91x1): Measurement grid: dx=15mm, dy=15mm
Maximum value of SAR (interpolated) = 0.389 mW/g

Right touch 661/Zoom Scan (5x5x7)/Cube 0: Measurement grid: dx=8mm, dy=8mm, dz=5mm
Reference Value = 6.89 V/m; Power Drift = -0.047 dB
Peak SAR (extrapolated) = 0.521 W/kg
SAR(1 g) = 0.353 mW/g; SAR(10 g) = 0.213 mW/g
Maximum value of SAR (measured) = 0.391 mW/g

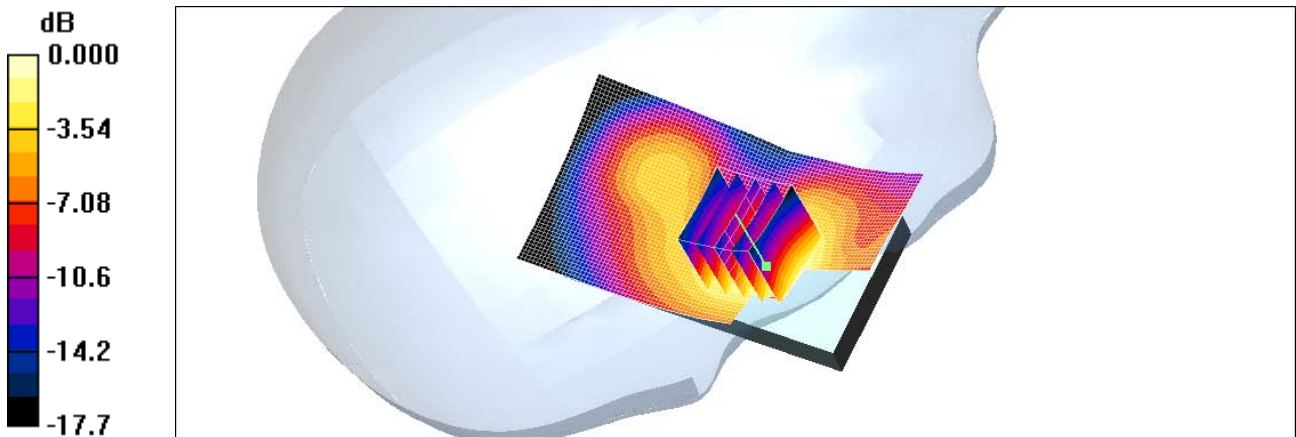

0 dB = 0.391 mW/g

Test Laboratory: HCT CO., LTD
EUT Type: GSM/WCDMA Phone with Bluetooth & WLAN
GPRS Class10 and GPRS mode class B(GPRS and GSM, but not simultaneously)
Liquid Temperature: 21.1 °C
Ambient Temperature: 21.3 °C
Test Date: Nov.16, 2010

DUT: P8000; Type: Bar; Serial: #1

Communication System: GSM 1900; Frequency: 1880 MHz; Duty Cycle: 1:8.3
Medium parameters used: $f = 1880 \text{ MHz}$; $\sigma = 1.38 \text{ mho/m}$; $\epsilon_r = 41$; $\rho = 1000 \text{ kg/m}^3$
Phantom section: Left Section ; Measurement SW: DASY4, V4.7 Build 80; Postprocessing SW: SEMCAD, V1.8 Build 184

DASY4 Configuration:

- Probe: ES3DV3 - SN3161; ConvF(4.79, 4.79, 4.79); Calibrated: 2010-03-22
- Sensor-Surface: 4mm (Mechanical Surface Detection)
- Electronics: DAE3 Sn446; Calibrated: 2010-09-21
- Phantom: 1800/1900 Phantom; Type: SAM

Left tilt 661/Area Scan (51x91x1): Measurement grid: $dx=15\text{mm}$, $dy=15\text{mm}$
Maximum value of SAR (interpolated) = 0.315 mW/g

Left tilt 661/Zoom Scan (5x5x7)/Cube 0: Measurement grid: $dx=8\text{mm}$, $dy=8\text{mm}$, $dz=5\text{mm}$
Reference Value = 13.7 V/m; Power Drift = -0.058 dB
Peak SAR (extrapolated) = 0.447 W/kg
SAR(1 g) = 0.269 mW/g; SAR(10 g) = 0.149 mW/g
Maximum value of SAR (measured) = 0.293 mW/g

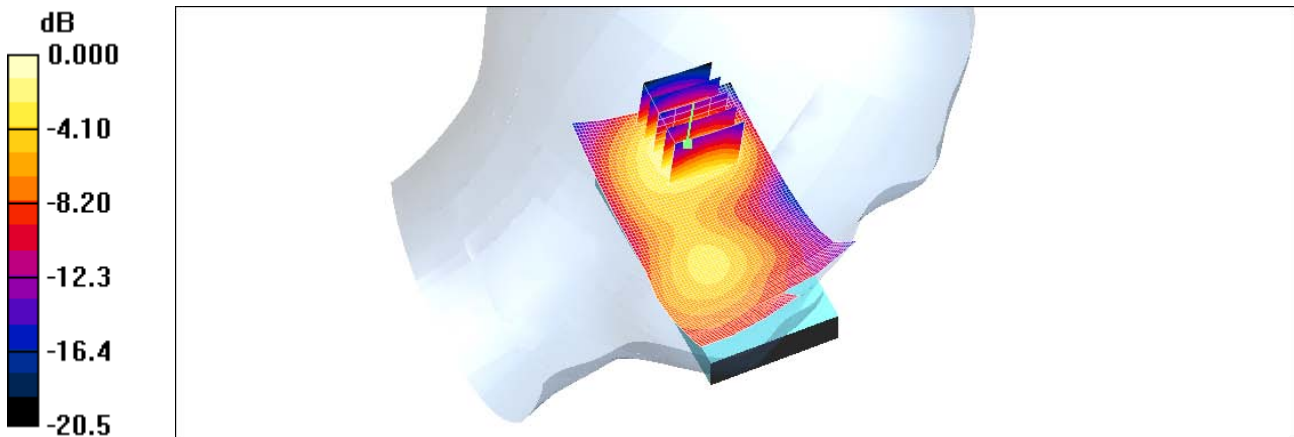

0 dB = 0.293mW/g

Test Laboratory: HCT CO., LTD
EUT Type: GSM/WCDMA Phone with Bluetooth & WLAN
GPRS Class10 and GPRS mode class B(GPRS and GSM, but not simultaneously)
Liquid Temperature: 21.1 °C
Ambient Temperature: 21.3 °C
Test Date: Nov.16, 2010

DUT: P8000; Type: Bar; Serial: #1

Communication System: GSM 1900; Frequency: 1880 MHz;Duty Cycle: 1:8.3
Medium parameters used: $f = 1880 \text{ MHz}$; $\sigma = 1.38 \text{ mho/m}$; $\epsilon_r = 41$; $\rho = 1000 \text{ kg/m}^3$
Phantom section: Right Section ; Measurement SW: DASY4, V4.7 Build 80; Postprocessing SW: SEMCAD, V1.8 Build 184

DASY4 Configuration:

- Probe: ES3DV3 - SN3161; ConvF(4.79, 4.79, 4.79); Calibrated: 2010-03-22
- Sensor-Surface: 4mm (Mechanical Surface Detection)
- Electronics: DAE3 Sn446; Calibrated: 2010-09-21
- Phantom: 1800/1900 Phantom; Type: SAM

Rightt tilt 661/Area Scan (51x91x1): Measurement grid: $dx=15\text{mm}$, $dy=15\text{mm}$
Maximum value of SAR (interpolated) = 0.262 mW/g

Rightt tilt 661/Zoom Scan (5x5x7)/Cube 0: Measurement grid: $dx=8\text{mm}$, $dy=8\text{mm}$, $dz=5\text{mm}$
Reference Value = 11.1 V/m; Power Drift = -0.139 dB
Peak SAR (extrapolated) = 0.376 W/kg
SAR(1 g) = 0.232 mW/g; SAR(10 g) = 0.135 mW/g
Maximum value of SAR (measured) = 0.247 mW/g

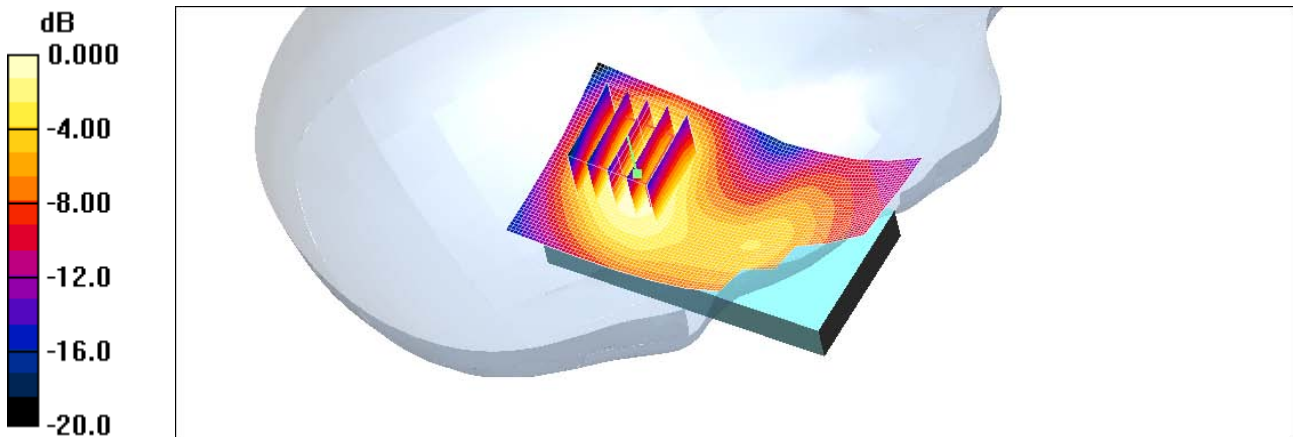

0 dB = 0.247mW/g

Test Laboratory: HCT CO., LTD
EUT Type: GSM/WCDMA Phone with Bluetooth & WLAN
GPRS Class10 and GPRS mode class B(GPRS and GSM, but not simultaneously)
Liquid Temperature: 21.4 °C
Ambient Temperature: 21.6 °C
Test Date: Nov.15, 2010

DUT: P8000; Type: Bar; Serial: #1

Communication System: WCDMA850; Frequency: 836.6 MHz; Duty Cycle: 1:1
Medium parameters used (interpolated): $f = 836.6$ MHz; $\sigma = 0.891$ mho/m; $\epsilon_r = 42.1$; $\rho = 1000$ kg/m³
Phantom section: Left Section ; Measurement SW: DASY4, V4.7 Build 80; Postprocessing SW: SEMCAD, V1.8 Build 184

DASY4 Configuration:

- Probe: ES3DV3 - SN3161; ConvF(5.96, 5.96, 5.96); Calibrated: 2010-03-22
- Sensor-Surface: 4mm (Mechanical Surface Detection)
- Electronics: DAE3 Sn446; Calibrated: 2010-09-21
- Phantom: 835/900 Phantom ; Type: SAM

Left touch 4183/Area Scan (51x91x1): Measurement grid: dx=15mm, dy=15mm

[Info: Interpolated medium parameters used for SAR evaluation.](#)

Maximum value of SAR (interpolated) = 0.386 mW/g

Left touch 4183/Zoom Scan (5x5x7)/Cube 0: Measurement grid: dx=8mm, dy=8mm, dz=5mm

Reference Value = 8.59 V/m; Power Drift = -0.078 dB

Peak SAR (extrapolated) = 0.467 W/kg

SAR(1 g) = 0.353 mW/g; SAR(10 g) = 0.256 mW/g

Maximum value of SAR (measured) = 0.373 mW/g

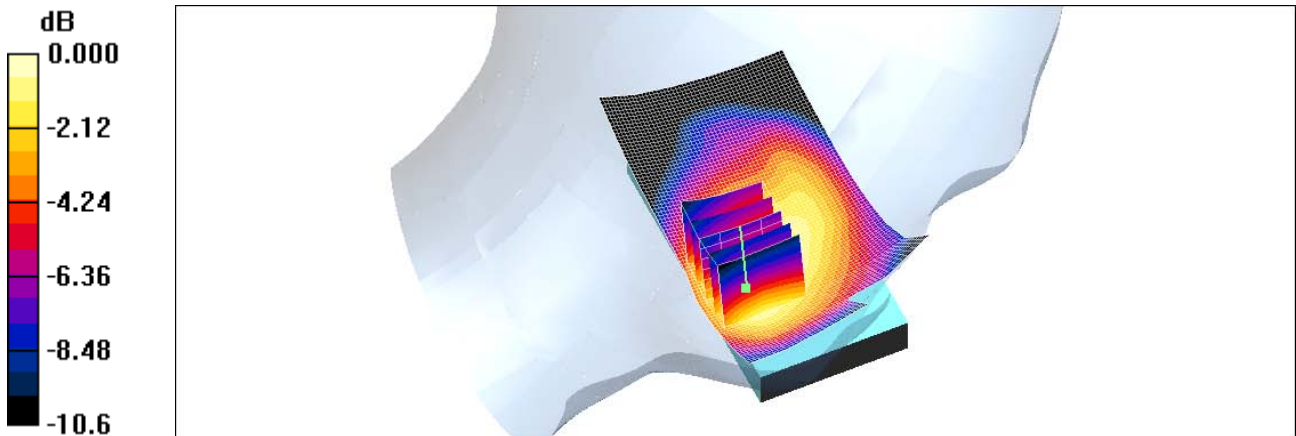

0 dB = 0.373mW/g

Test Laboratory: HCT CO., LTD
EUT Type: GSM/WCDMA Phone with Bluetooth & WLAN
GPRS Class10 and GPRS mode class B(GPRS and GSM, but not simultaneously)
Liquid Temperature: 21.4 °C
Ambient Temperature: 21.6 °C
Test Date: Nov.15, 2010

DUT: P8000; Type: Bar; Serial: #1

Communication System: WCDMA850; Frequency: 836.6 MHz; Duty Cycle: 1:1
Medium parameters used (interpolated): $f = 836.6$ MHz; $\sigma = 0.891$ mho/m; $\epsilon_r = 42.1$; $\rho = 1000$ kg/m³
Phantom section: Right Section ; Measurement SW: DASY4, V4.7 Build 80; Postprocessing SW: SEMCAD, V1.8 Build 184

DASY4 Configuration:

- Probe: ES3DV3 - SN3161; ConvF(5.96, 5.96, 5.96); Calibrated: 2010-03-22
- Sensor-Surface: 4mm (Mechanical Surface Detection)
- Electronics: DAE3 Sn446; Calibrated: 2010-09-21
- Phantom: 835/900 Phantom ; Type: SAM

Right touch 4183/Area Scan (51x91x1): Measurement grid: dx=15mm, dy=15mm

[Info: Interpolated medium parameters used for SAR evaluation.](#)

Maximum value of SAR (interpolated) = 0.319 mW/g

Right touch 4183/Zoom Scan (5x5x7)/Cube 0: Measurement grid: dx=8mm, dy=8mm, dz=5mm

Reference Value = 8.64 V/m; Power Drift = 0.082 dB

Peak SAR (extrapolated) = 0.387 W/kg

SAR(1 g) = 0.305 mW/g; SAR(10 g) = 0.230 mW/g

[Info: Interpolated medium parameters used for SAR evaluation.](#)

Maximum value of SAR (measured) = 0.319 mW/g

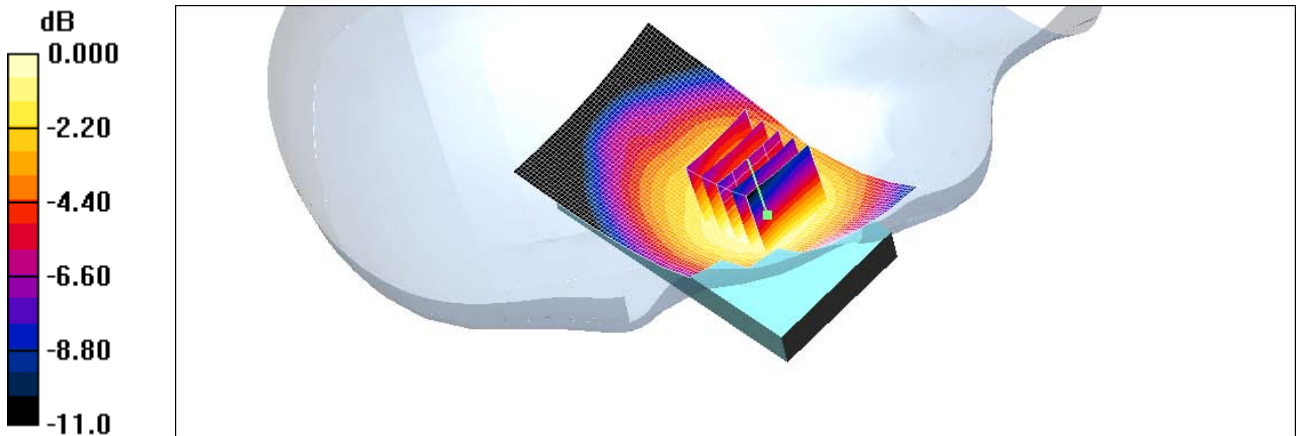

Test Laboratory: HCT CO., LTD
EUT Type: GSM/WCDMA Phone with Bluetooth & WLAN
GPRS Class10 and GPRS mode class B(GPRS and GSM, but not simultaneously)
Liquid Temperature: 21.4 °C
Ambient Temperature: 21.6 °C
Test Date: Nov.15, 2010

DUT: P8000; Type: Bar; Serial: #1

Communication System: WCDMA850; Frequency: 836.6 MHz; Duty Cycle: 1:1
Medium parameters used (interpolated): $f = 836.6$ MHz; $\sigma = 0.891$ mho/m; $\epsilon_r = 42.1$; $\rho = 1000$ kg/m³
Phantom section: Left Section ; Measurement SW: DASY4, V4.7 Build 80; Postprocessing SW: SEMCAD, V1.8 Build 184

DASY4 Configuration:

- Probe: ES3DV3 - SN3161; ConvF(5.96, 5.96, 5.96); Calibrated: 2010-03-22
- Sensor-Surface: 4mm (Mechanical Surface Detection)
- Electronics: DAE3 Sn446; Calibrated: 2010-09-21
- Phantom: 835/900 Phantom ; Type: SAM

Left tilt 4183/Area Scan (51x91x1): Measurement grid: dx=15mm, dy=15mm

[Info: Interpolated medium parameters used for SAR evaluation.](#)

Maximum value of SAR (interpolated) = 0.230 mW/g

Left tilt 4183/Zoom Scan (5x5x7)/Cube 0: Measurement grid: dx=8mm, dy=8mm, dz=5mm

Reference Value = 12.7 V/m; Power Drift = 0.043 dB

Peak SAR (extrapolated) = 0.289 W/kg

SAR(1 g) = 0.232 mW/g; SAR(10 g) = 0.175 mW/g

[Info: Interpolated medium parameters used for SAR evaluation.](#)

Maximum value of SAR (measured) = 0.244 mW/g

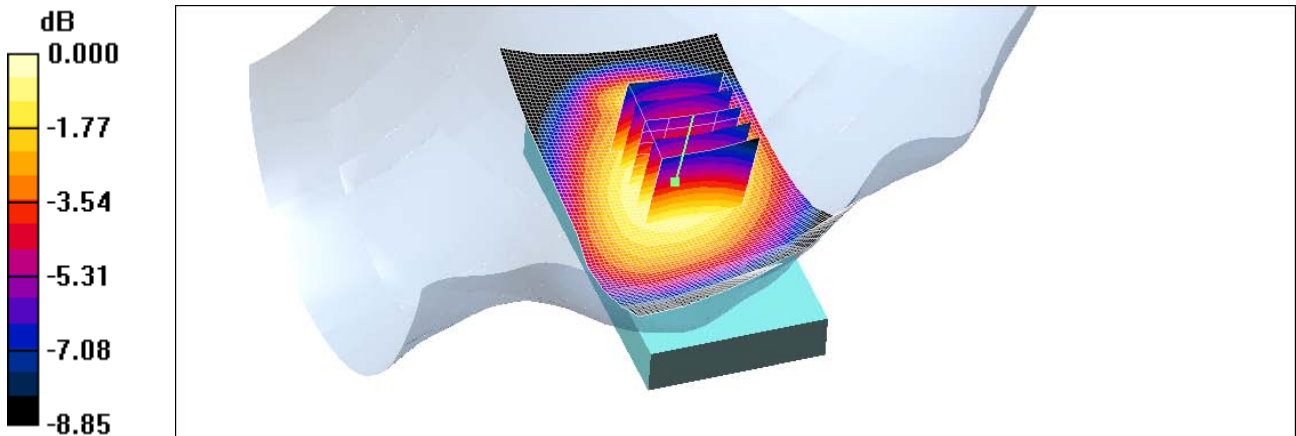

0 dB = 0.244mW/g

Test Laboratory: HCT CO., LTD
EUT Type: GSM/WCDMA Phone with Bluetooth & WLAN
GPRS Class10 and GPRS mode class B(GPRS and GSM, but not simultaneously)
Liquid Temperature: 21.4 °C
Ambient Temperature: 21.6 °C
Test Date: Nov.15, 2010

DUT: P8000; Type: Bar; Serial: #1

Communication System: WCDMA850; Frequency: 836.6 MHz; Duty Cycle: 1:1
Medium parameters used (interpolated): $f = 836.6$ MHz; $\sigma = 0.891$ mho/m; $\epsilon_r = 42.1$; $\rho = 1000$ kg/m³
Phantom section: Right Section ; Measurement SW: DASY4, V4.7 Build 80; Postprocessing SW: SEMCAD, V1.8 Build 184

DASY4 Configuration:

- Probe: ES3DV3 - SN3161; ConvF(5.96, 5.96, 5.96); Calibrated: 2010-03-22
- Sensor-Surface: 4mm (Mechanical Surface Detection)
- Electronics: DAE3 Sn446; Calibrated: 2010-09-21
- Phantom: 835/900 Phantom ; Type: SAM

Right tilt 4183/Area Scan (51x91x1): Measurement grid: dx=15mm, dy=15mm

[Info: Interpolated medium parameters used for SAR evaluation.](#)

Maximum value of SAR (interpolated) = 0.217 mW/g

Right tilt 4183/Zoom Scan (5x5x7)/Cube 0: Measurement grid: dx=8mm, dy=8mm, dz=5mm

Reference Value = 12.3 V/m; Power Drift = 0.006 dB

Peak SAR (extrapolated) = 0.260 W/kg

SAR(1 g) = 0.212 mW/g; SAR(10 g) = 0.163 mW/g

[Info: Interpolated medium parameters used for SAR evaluation.](#)

Maximum value of SAR (measured) = 0.222 mW/g

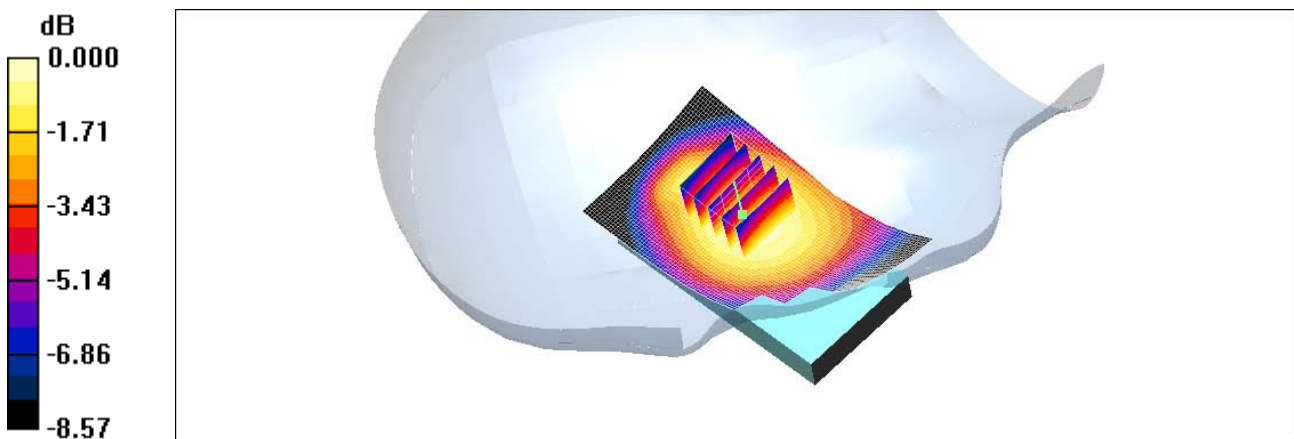

0 dB = 0.222mW/g

Test Laboratory: HCT CO., LTD
EUT Type: GSM/WCDMA Phone with Bluetooth & WLAN
GPRS Class10 and GPRS mode class B(GPRS and GSM, but not simultaneously)
Liquid Temperature: 21.1 °C
Ambient Temperature: 21.3 °C
Test Date: Nov.16, 2010

DUT: P8000; Type: Bar; Serial: #1

Communication System: WCDMA1900(FCC); Frequency: 1852.4 MHz; Duty Cycle: 1:1
Medium parameters used (interpolated): $f = 1852.4$ MHz; $\sigma = 1.36$ mho/m; $\epsilon_r = 41.2$; $\rho = 1000$ kg/m³
Phantom section: Left Section ; Measurement SW: DASY4, V4.7 Build 80; Postprocessing SW: SEMCAD, V1.8 Build 184

DASY4 Configuration:

- Probe: ES3DV3 - SN3161; ConvF(4.79, 4.79, 4.79); Calibrated: 2010-03-22
- Sensor-Surface: 4mm (Mechanical Surface Detection)
- Electronics: DAE3 Sn446; Calibrated: 2010-09-21
- Phantom: 1800/1900 Phantom; Type: SAM

Left touch 9262/Area Scan (51x91x1): Measurement grid: dx=15mm, dy=15mm

[Info: Interpolated medium parameters used for SAR evaluation.](#)

Maximum value of SAR (interpolated) = 1.04 mW/g

Left touch 9262/Zoom Scan (5x5x7)/Cube 0: Measurement grid: dx=8mm, dy=8mm, dz=5mm

Reference Value = 13.2 V/m; Power Drift = 0.090 dB

Peak SAR (extrapolated) = 1.59 W/kg

SAR(1 g) = 1.05 mW/g; SAR(10 g) = 0.608 mW/g

[Info: Interpolated medium parameters used for SAR evaluation.](#)

Maximum value of SAR (measured) = 1.14 mW/g

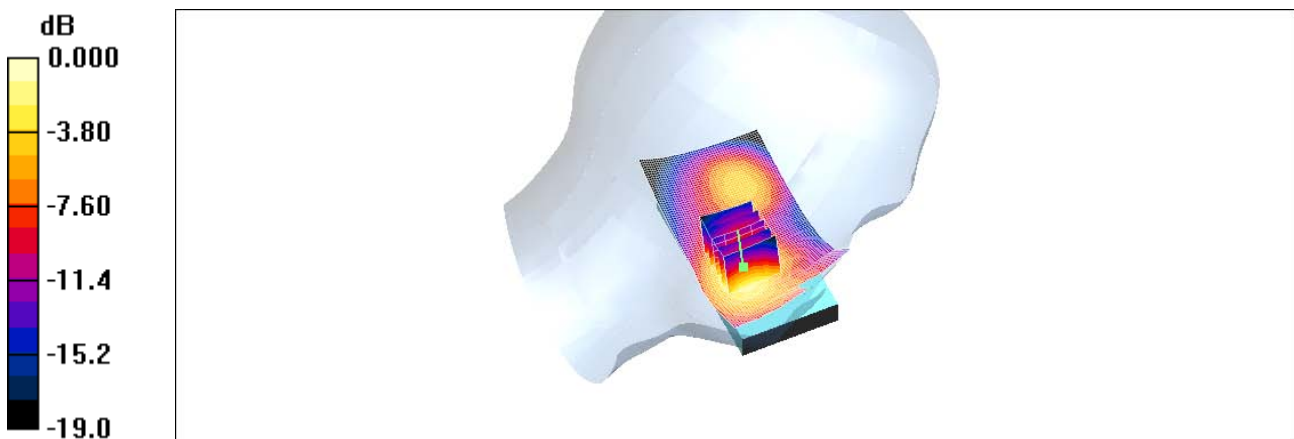

0 dB = 1.14mW/g

Test Laboratory: HCT CO., LTD
 EUT Type: GSM/WCDMA Phone with Bluetooth & WLAN
 GPRS Class10 and GPRS mode class B(GPRS and GSM, but not simultaneously)
 Liquid Temperature: 21.1 °C
 Ambient Temperature: 21.3 °C
 Test Date: Nov.16, 2010

DUT: P8000; Type: Bar; Serial: #1

Communication System: WCDMA1900(FCC); Frequency: 1880 MHz;Duty Cycle: 1:1
 Medium parameters used: $f = 1880 \text{ MHz}$; $\sigma = 1.38 \text{ mho/m}$; $\epsilon_r = 41$; $\rho = 1000 \text{ kg/m}^3$
 Phantom section: Left Section ; Measurement SW: DASY4, V4.7 Build 80; Postprocessing SW: SEMCAD, V1.8 Build 184

DASY4 Configuration:
 - Probe: ES3DV3 - SN3161; ConvF(4.79, 4.79, 4.79); Calibrated: 2010-03-22
 - Sensor-Surface: 4mm (Mechanical Surface Detection)
 - Electronics: DAE3 Sn446; Calibrated: 2010-09-21
 - Phantom: 1800/1900 Phantom; Type: SAM

Left touch 9400/Area Scan (51x91x1): Measurement grid: dx=15mm, dy=15mm
 Maximum value of SAR (interpolated) = 1.19 mW/g

Left touch 9400/Zoom Scan (5x5x7)/Cube 0: Measurement grid: dx=8mm, dy=8mm, dz=5mm
 Reference Value = 13.8 V/m; Power Drift = -0.004 dB
 Peak SAR (extrapolated) = 1.59 W/kg
SAR(1 g) = 1.03 mW/g; SAR(10 g) = 0.593 mW/g
 Maximum value of SAR (measured) = 1.13 mW/g

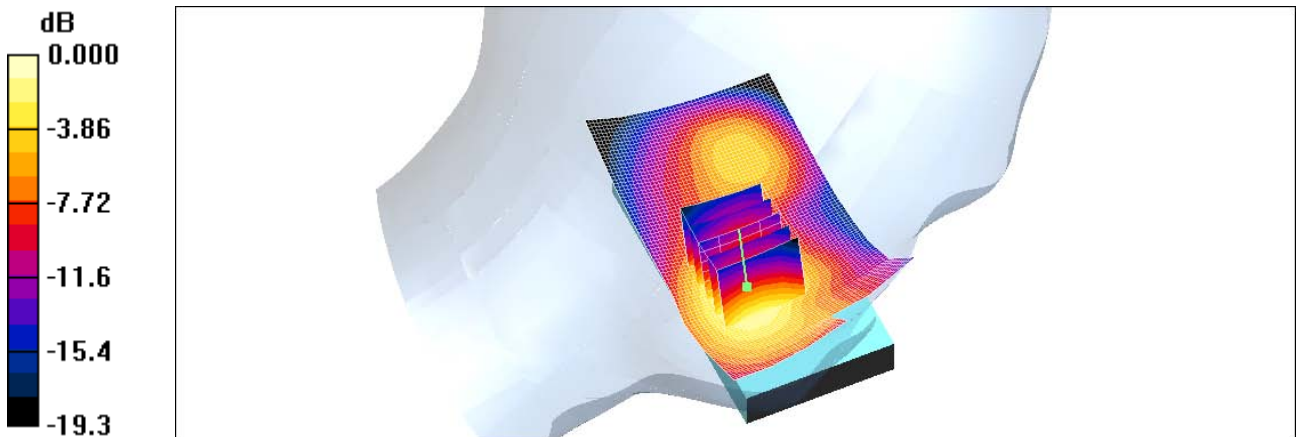

0 dB = 1.13mW/g

Test Laboratory: HCT CO., LTD
EUT Type: GSM/WCDMA Phone with Bluetooth & WLAN
GPRS Class10 and GPRS mode class B(GPRS and GSM, but not simultaneously)
Liquid Temperature: 21.1 °C
Ambient Temperature: 21.3 °C
Test Date: Nov.16, 2010

DUT: P8000; Type: Bar; Serial: #1

Communication System: WCDMA1900(FCC); Frequency: 1907.6 MHz;Duty Cycle: 1:1
Medium parameters used (interpolated): $f = 1907.6 \text{ MHz}$; $\sigma = 1.4 \text{ mho/m}$; $\epsilon_r = 40.8$; $\rho = 1000 \text{ kg/m}^3$
Phantom section: Left Section ; Measurement SW: DASY4, V4.7 Build 80; Postprocessing SW: SEMCAD, V1.8 Build 184

DASY4 Configuration:

- Probe: ES3DV3 - SN3161; ConvF(4.79, 4.79, 4.79); Calibrated: 2010-03-22
- Sensor-Surface: 4mm (Mechanical Surface Detection)
- Electronics: DAE3 Sn446; Calibrated: 2010-09-21
- Phantom: 1800/1900 Phantom; Type: SAM

Left touch 9538/Area Scan (51x91x1): Measurement grid: dx=15mm, dy=15mm

[Info: Interpolated medium parameters used for SAR evaluation.](#)

Maximum value of SAR (interpolated) = 1.32 mW/g

Left touch 9538/Zoom Scan (5x5x7)/Cube 0: Measurement grid: dx=8mm, dy=8mm, dz=5mm

Reference Value = 13.2 V/m; Power Drift = -0.086 dB

Peak SAR (extrapolated) = 1.79 W/kg

SAR(1 g) = 1.16 mW/g; SAR(10 g) = 0.665 mW/g

[Info: Interpolated medium parameters used for SAR evaluation.](#)

Maximum value of SAR (measured) = 1.26 mW/g

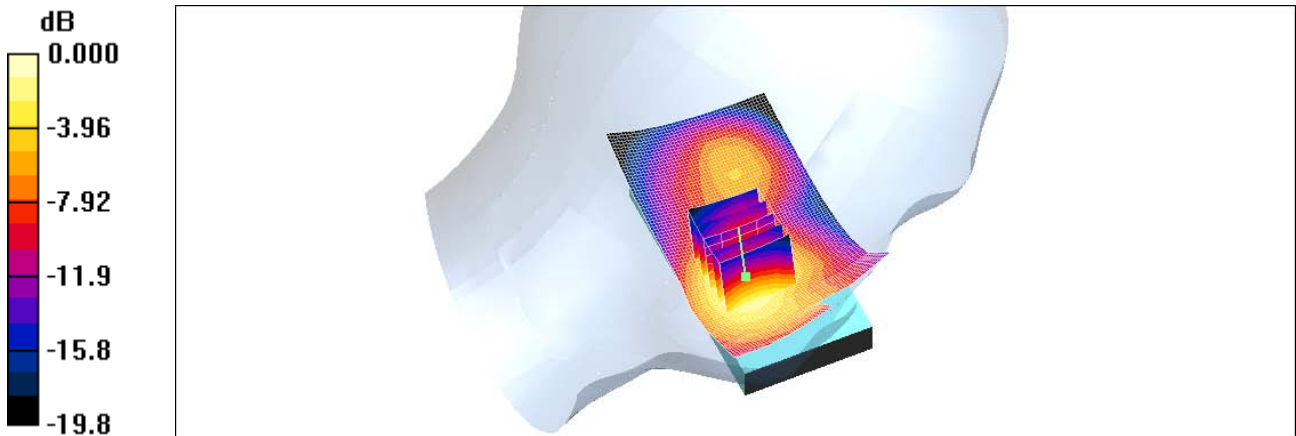

0 dB = 1.26mW/g

Test Laboratory: HCT CO., LTD
EUT Type: GSM/WCDMA Phone with Bluetooth & WLAN
GPRS Class10 and GPRS mode class B(GPRS and GSM, but not simultaneously)
Liquid Temperature: 21.1 °C
Ambient Temperature: 21.3 °C
Test Date: Nov.16, 2010

DUT: P8000; Type: Bar; Serial: #1

Communication System: WCDMA1900(FCC); Frequency: 1880 MHz;Duty Cycle: 1:1
Medium parameters used: $f = 1880$ MHz; $\sigma = 1.38$ mho/m; $\epsilon_r = 41$; $\rho = 1000$ kg/m³
Phantom section: Right Section ; Measurement SW: DASY4, V4.7 Build 80; Postprocessing SW: SEMCAD, V1.8 Build 184

DASY4 Configuration:

- Probe: ES3DV3 - SN3161; ConvF(4.79, 4.79, 4.79); Calibrated: 2010-03-22
- Sensor-Surface: 4mm (Mechanical Surface Detection)
- Electronics: DAE3 Sn446; Calibrated: 2010-09-21
- Phantom: 1800/1900 Phantom; Type: SAM

Right touch 9400/Area Scan (51x91x1): Measurement grid: dx=15mm, dy=15mm
Maximum value of SAR (interpolated) = 0.739 mW/g

Right touch 9400/Zoom Scan (5x5x7)/Cube 0: Measurement grid: dx=8mm, dy=8mm, dz=5mm
Reference Value = 10.4 V/m; Power Drift = -0.027 dB
Peak SAR (extrapolated) = 1.02 W/kg
SAR(1 g) = 0.689 mW/g; SAR(10 g) = 0.419 mW/g
Maximum value of SAR (measured) = 0.757 mW/g

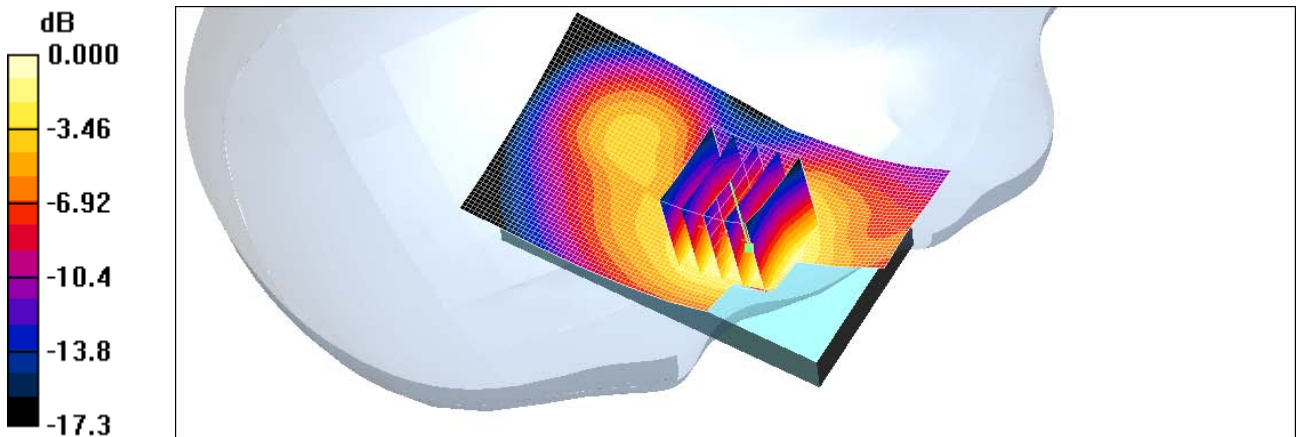

0 dB = 0.757mW/g

Test Laboratory: HCT CO., LTD
EUT Type: GSM/WCDMA Phone with Bluetooth & WLAN
GPRS Class10 and GPRS mode class B(GPRS and GSM, but not simultaneously)
Liquid Temperature: 21.1 °C
Ambient Temperature: 21.3 °C
Test Date: Nov.16, 2010

DUT: P8000; Type: Bar; Serial: #1

Communication System: WCDMA1900(FCC); Frequency: 1880 MHz;Duty Cycle: 1:1
Medium parameters used: $f = 1880 \text{ MHz}$; $\sigma = 1.38 \text{ mho/m}$; $\epsilon_r = 41$; $\rho = 1000 \text{ kg/m}^3$
Phantom section: Left Section ; Measurement SW: DASY4, V4.7 Build 80; Postprocessing SW: SEMCAD, V1.8 Build 184

DASY4 Configuration:

- Probe: ES3DV3 - SN3161; ConvF(4.79, 4.79, 4.79); Calibrated: 2010-03-22
- Sensor-Surface: 4mm (Mechanical Surface Detection)
- Electronics: DAE3 Sn446; Calibrated: 2010-09-21
- Phantom: 1800/1900 Phantom; Type: SAM

Left tilt 9400/Area Scan (51x91x1): Measurement grid: dx=15mm, dy=15mm
Maximum value of SAR (interpolated) = 0.614 mW/g

Left tilt 9400/Zoom Scan (5x5x7)/Cube 0: Measurement grid: dx=8mm, dy=8mm, dz=5mm
Reference Value = 17.7 V/m; Power Drift = -0.002 dB
Peak SAR (extrapolated) = 0.856 W/kg
SAR(1 g) = 0.513 mW/g; SAR(10 g) = 0.286 mW/g
Maximum value of SAR (measured) = 0.560 mW/g

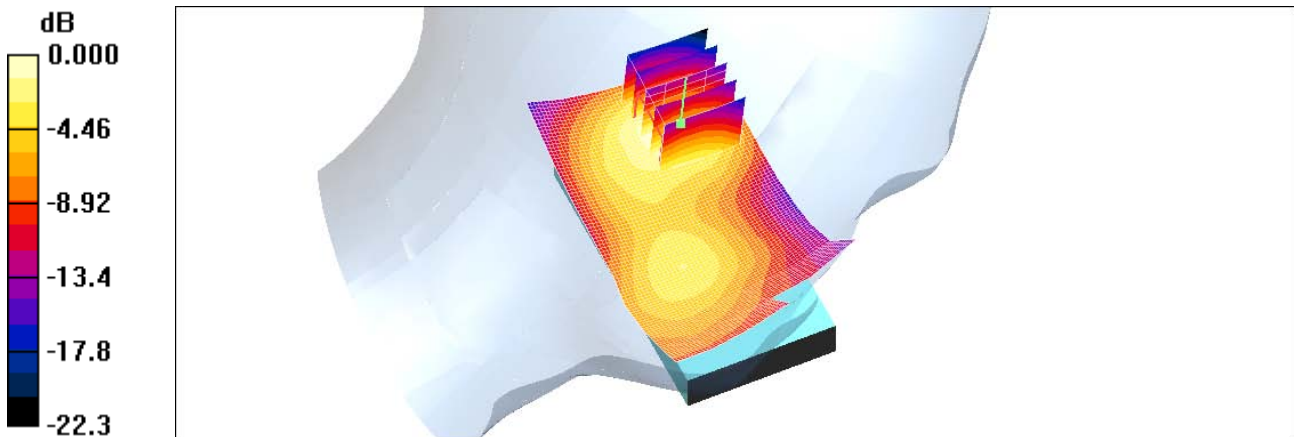

0 dB = 0.560mW/g

Test Laboratory: HCT CO., LTD
EUT Type: GSM/WCDMA Phone with Bluetooth & WLAN
GPRS Class10 and GPRS mode class B(GPRS and GSM, but not simultaneously)
Liquid Temperature: 21.1 °C
Ambient Temperature: 21.3 °C
Test Date: Nov.16, 2010

DUT: P8000; Type: Bar; Serial: #1

Communication System: WCDMA1900(FCC); Frequency: 1880 MHz;Duty Cycle: 1:1
Medium parameters used: $f = 1880 \text{ MHz}$; $\sigma = 1.38 \text{ mho/m}$; $\epsilon_r = 41$; $\rho = 1000 \text{ kg/m}^3$
Phantom section: Right Section ; Measurement SW: DASY4, V4.7 Build 80; Postprocessing SW: SEMCAD, V1.8 Build 184

DASY4 Configuration:

- Probe: ES3DV3 - SN3161; ConvF(4.79, 4.79, 4.79); Calibrated: 2010-03-22
- Sensor-Surface: 4mm (Mechanical Surface Detection)
- Electronics: DAE3 Sn446; Calibrated: 2010-09-21
- Phantom: 1800/1900 Phantom; Type: SAM

Rightt tilt 9400/Area Scan (51x91x1): Measurement grid: dx=15mm, dy=15mm
Maximum value of SAR (interpolated) = 0.492 mW/g

Rightt tilt 9400/Zoom Scan (5x5x7)/Cube 0: Measurement grid: dx=8mm, dy=8mm, dz=5mm
Reference Value = 16.3 V/m; Power Drift = -0.07 dB
Peak SAR (extrapolated) = 0.708 W/kg
SAR(1 g) = 0.444 mW/g; SAR(10 g) = 0.261 mW/g
Maximum value of SAR (measured) = 0.470 mW/g

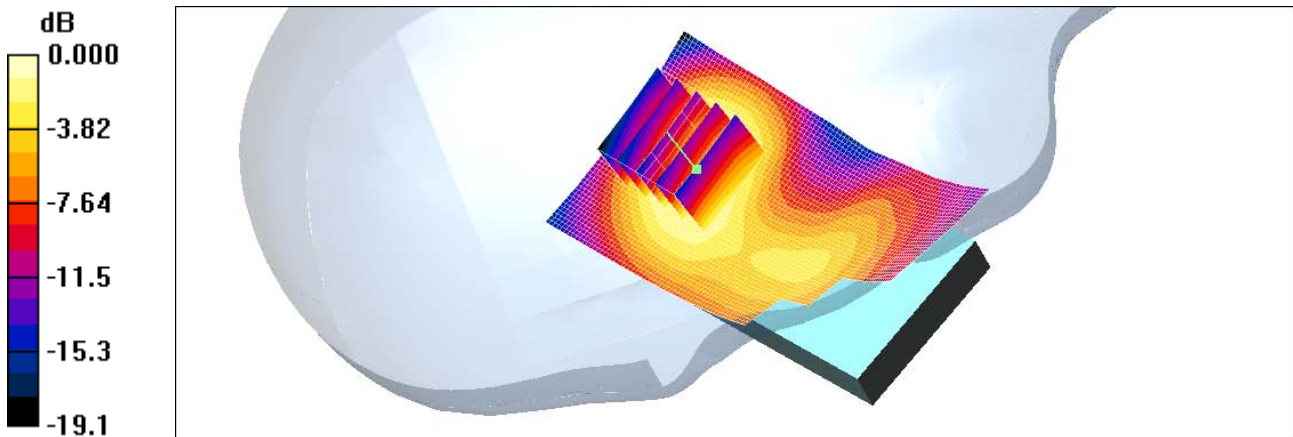

0 dB = 0.470mW/g

Test Laboratory: HCT CO., LTD
EUT Type: GSM/WCDMA Phone with Bluetooth & WLAN
GPRS Class10 and GPRS mode class B(GPRS and GSM, but not simultaneously)
Liquid Temperature: 21.1 °C
Ambient Temperature: 21.3 °C
Test Date: Dec. 7, 2010

DUT: P8000; Type: Bar; Serial: #1

Communication System: 2450MHz FCC; Frequency: 2437 MHz;Duty Cycle: 1:1
Medium parameters used (interpolated): $f = 2437$ MHz; $\sigma = 1.84$ mho/m; $\epsilon_r = 38.3$; $\rho = 1000$ kg/m³
Phantom section: Left Section ; Measurement SW: DASY4, V4.7 Build 80; Postprocessing SW: SEMCAD, V1.8 Build 184

DASY4 Configuration:

- Probe: ES3DV3 - SN3161; ConvF(4.26, 4.26, 4.26); Calibrated: 2010-03-22
- Sensor-Surface: 4mm (Mechanical Surface Detection)
- Electronics: DAE3 Sn446; Calibrated: 2010-09-21
- Phantom: 1800/1900 Phantom; Type: SAM

Left touch 6/Area Scan (51x91x1): Measurement grid: dx=15mm, dy=15mm

[Info: Interpolated medium parameters used for SAR evaluation.](#)

Maximum value of SAR (interpolated) = 0.637 mW/g

Left touch 6/Zoom Scan (5x5x7)/Cube 0: Measurement grid: dx=8mm, dy=8mm, dz=5mm

Reference Value = 16.5 V/m; Power Drift = -0.310 dB

Peak SAR (extrapolated) = 1.52 W/kg

SAR(1 g) = 0.575 mW/g; SAR(10 g) = 0.267 mW/g

[Info: Interpolated medium parameters used for SAR evaluation.](#)

Maximum value of SAR (measured) = 0.567 mW/g

Left touch 6/Zoom Scan (5x5x7)/Cube 1: Measurement grid: dx=8mm, dy=8mm, dz=5mm

Reference Value = 16.5 V/m; Power Drift = -0.0130 dB

Peak SAR (extrapolated) = 1.14 W/kg

SAR(1 g) = 0.448 mW/g; SAR(10 g) = 0.214 mW/g

[Info: Interpolated medium parameters used for SAR evaluation.](#)

Maximum value of SAR (measured) = 0.509 mW/g

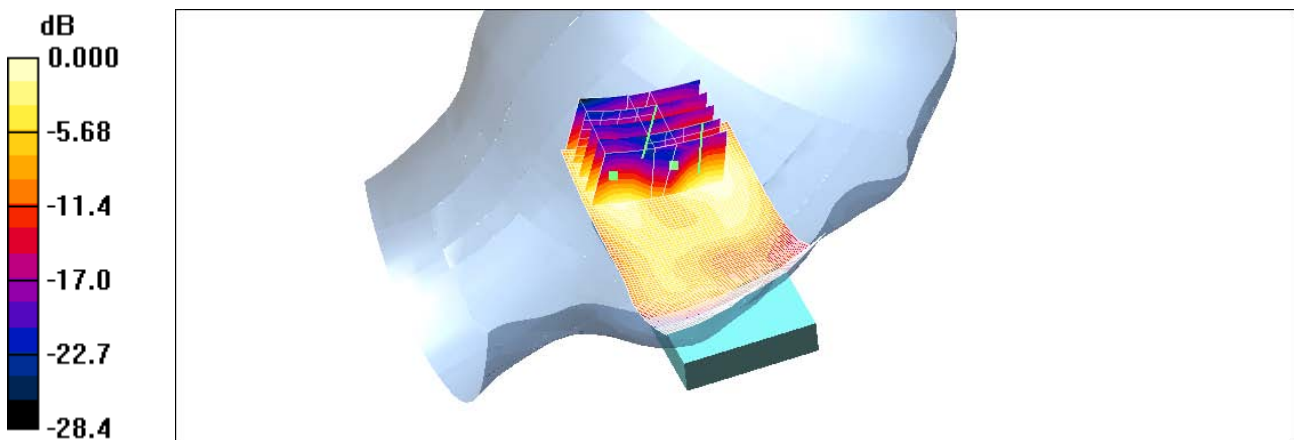

0 dB = 0.509mW/g

Test Laboratory: HCT CO., LTD
EUT Type: GSM/WCDMA Phone with Bluetooth & WLAN
GPRS Class10 and GPRS mode class B(GPRS and GSM, but not simultaneously)
Liquid Temperature: 21.1 °C
Ambient Temperature: 21.3 °C
Test Date: Dec. 7, 2010

DUT: P8000; Type: Bar; Serial: #1

Communication System: 2450MHz FCC; Frequency: 2437 MHz;Duty Cycle: 1:1
Medium parameters used (interpolated): $f = 2437$ MHz; $\sigma = 1.84$ mho/m; $\epsilon_r = 38.3$; $\rho = 1000$ kg/m³
Phantom section: Right Section ; Measurement SW: DASY4, V4.7 Build 80; Postprocessing SW: SEMCAD, V1.8 Build 184

DASY4 Configuration:

- Probe: ES3DV3 - SN3161; ConvF(4.26, 4.26, 4.26); Calibrated: 2010-03-22
- Sensor-Surface: 4mm (Mechanical Surface Detection)
- Electronics: DAE3 Sn446; Calibrated: 2010-09-21
- Phantom: 1800/1900 Phantom; Type: SAM

Right touch 6/Area Scan (51x91x1): Measurement grid: dx=15mm, dy=15mm

[Info: Interpolated medium parameters used for SAR evaluation.](#)

Maximum value of SAR (interpolated) = 0.631 mW/g

Right touch 6/Zoom Scan (5x5x7)/Cube 0: Measurement grid: dx=8mm, dy=8mm, dz=5mm

Reference Value = 14.0 V/m; Power Drift = -0.103 dB

Peak SAR (extrapolated) = 1.71 W/kg

SAR(1 g) = 0.671 mW/g; SAR(10 g) = 0.283 mW/g

[Info: Interpolated medium parameters used for SAR evaluation.](#)

Maximum value of SAR (measured) = 0.740 mW/g

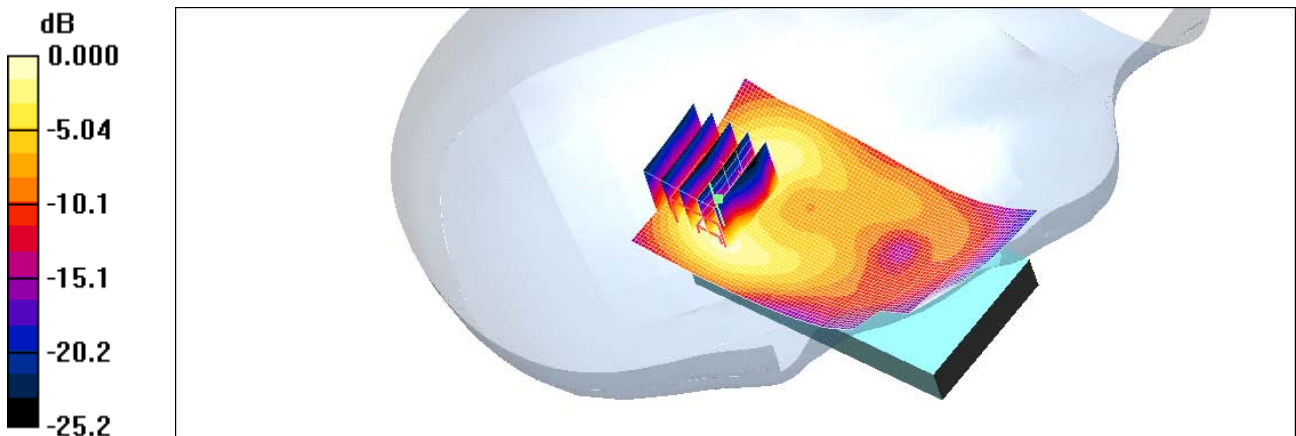

Test Laboratory: HCT CO., LTD
EUT Type: GSM/WCDMA Phone with Bluetooth & WLAN
GPRS Class10 and GPRS mode class B(GPRS and GSM, but not simultaneously)
Liquid Temperature: 21.1 °C
Ambient Temperature: 21.3 °C
Test Date: Dec. 7, 2010

DUT: P8000; Type: Bar; Serial: #1

Communication System: 2450MHz FCC; Frequency: 2437 MHz;Duty Cycle: 1:1
Medium parameters used (interpolated): $f = 2437$ MHz; $\sigma = 1.84$ mho/m; $\epsilon_r = 38.3$; $\rho = 1000$ kg/m³
Phantom section: Left Section ; Measurement SW: DASY4, V4.7 Build 80; Postprocessing SW: SEMCAD, V1.8 Build 184

DASY4 Configuration:

- Probe: ES3DV3 - SN3161; ConvF(4.26, 4.26, 4.26); Calibrated: 2010-03-22
- Sensor-Surface: 4mm (Mechanical Surface Detection)
- Electronics: DAE3 Sn446; Calibrated: 2010-09-21
- Phantom: 1800/1900 Phantom; Type: SAM

Left tilt 6/Area Scan (51x91x1): Measurement grid: dx=15mm, dy=15mm

[Info: Interpolated medium parameters used for SAR evaluation.](#)

Maximum value of SAR (interpolated) = 0.753 mW/g

Left tilt 6/Zoom Scan (5x5x7)/Cube 0: Measurement grid: dx=8mm, dy=8mm, dz=5mm

Reference Value = 17.2 V/m; Power Drift = 0.038 dB

Peak SAR (extrapolated) = 1.56 W/kg

SAR(1 g) = 0.691 mW/g; SAR(10 g) = 0.328 mW/g

[Info: Interpolated medium parameters used for SAR evaluation.](#)

Maximum value of SAR (measured) = 0.773 mW/g

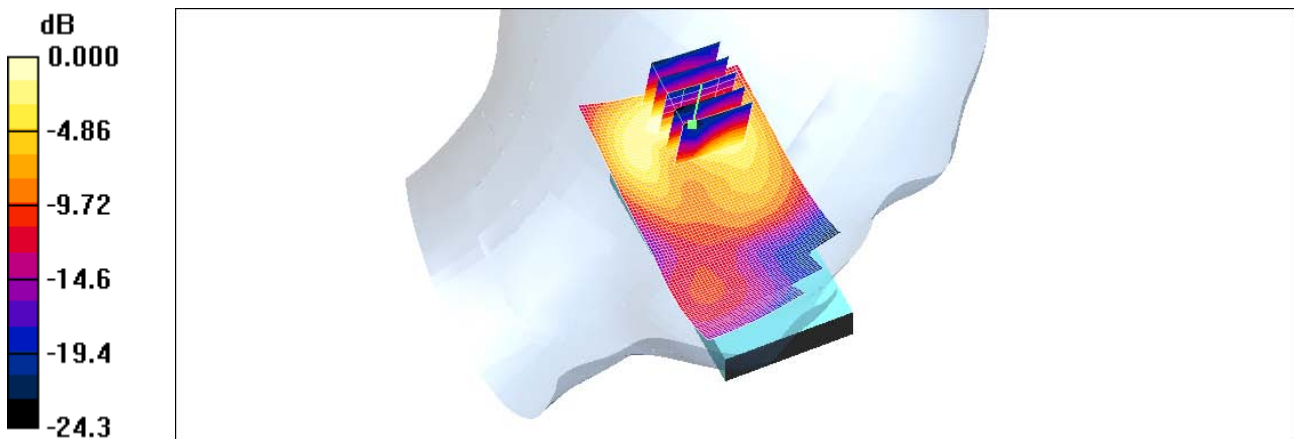

0 dB = 0.773mW/g

Test Laboratory: HCT CO., LTD
EUT Type: GSM/WCDMA Phone with Bluetooth & WLAN
GPRS Class10 and GPRS mode class B(GPRS and GSM, but not simultaneously)
Liquid Temperature: 21.1 °C
Ambient Temperature: 21.3 °C
Test Date: Dec. 7, 2010

DUT: P8000; Type: Bar; Serial: #1

Communication System: 2450MHz FCC; Frequency: 2437 MHz;Duty Cycle: 1:1
Medium parameters used (interpolated): $f = 2437$ MHz; $\sigma = 1.84$ mho/m; $\epsilon_r = 38.3$; $\rho = 1000$ kg/m³
Phantom section: Right Section ; Measurement SW: DASY4, V4.7 Build 80; Postprocessing SW: SEMCAD, V1.8 Build 184

DASY4 Configuration:

- Probe: ES3DV3 - SN3161; ConvF(4.26, 4.26, 4.26); Calibrated: 2010-03-22
- Sensor-Surface: 4mm (Mechanical Surface Detection)
- Electronics: DAE3 Sn446; Calibrated: 2010-09-21
- Phantom: 1800/1900 Phantom; Type: SAM

Right tilt 6/Area Scan (51x91x1): Measurement grid: dx=15mm, dy=15mm

[Info: Interpolated medium parameters used for SAR evaluation.](#)

Maximum value of SAR (interpolated) = 0.804 mW/g

Right tilt 6/Zoom Scan (5x5x7)/Cube 0: Measurement grid: dx=8mm, dy=8mm, dz=5mm

Reference Value = 19.1 V/m; Power Drift = 0.023 dB

Peak SAR (extrapolated) = 1.93 W/kg

SAR(1 g) = 0.768 mW/g; SAR(10 g) = 0.356 mW/g

[Info: Interpolated medium parameters used for SAR evaluation.](#)

Maximum value of SAR (measured) = 0.833 mW/g

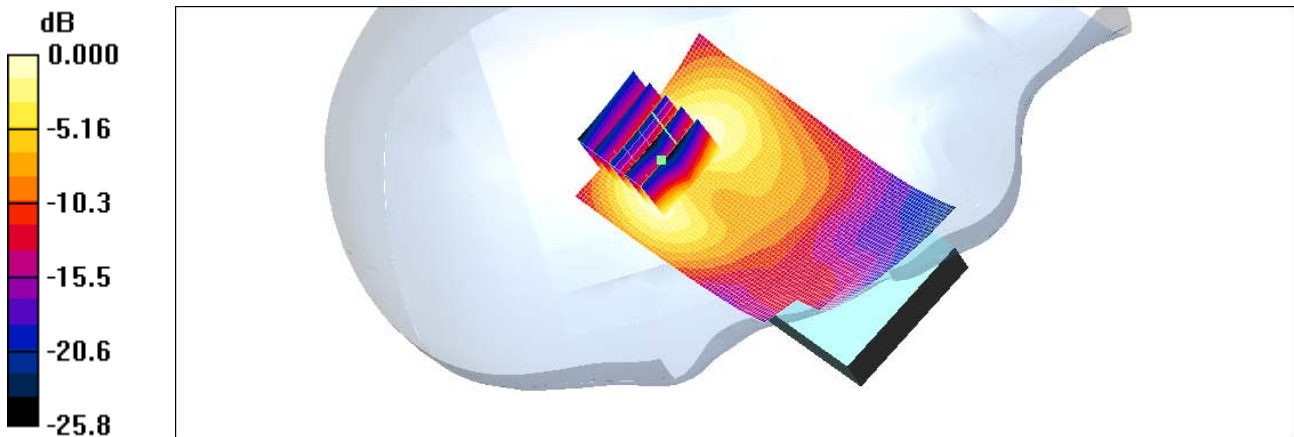

0 dB = 0.833mW/g

Test Laboratory: HCT CO., LTD
EUT Type: GSM/WCDMA Phone with Bluetooth & WLAN
GPRS Class10 and GPRS mode class B(GPRS and GSM, but not simultaneously)
Liquid Temperature: 21.4 °C
Ambient Temperature: 21.6 °C
Test Date: Nov.15, 2010

DUT: P8000; Type: Bar; Serial: #1

Communication System: GSM 850; Frequency: 824.2 MHz; Duty Cycle: 1:4.15
Medium parameters used: $f = 825$ MHz; $\sigma = 0.974$ mho/m; $\epsilon_r = 56.9$; $\rho = 1000$ kg/m³
Phantom section: Flat Section ; Measurement SW: DASY4, V4.7 Build 80; Postprocessing SW: SEMCAD, V1.8 Build 184

DASY4 Configuration:

- Probe: ES3DV3 - SN3161; ConvF(5.84, 5.84, 5.84); Calibrated: 2010-03-22
- Sensor-Surface: 4mm (Mechanical Surface Detection)
- Electronics: DAE3 Sn446; Calibrated: 2010-09-21
- Phantom: 835/900 Phantom ; Type: SAM

GSM Body 128/Area Scan (51x91x1): Measurement grid: dx=15mm, dy=15mm
Maximum value of SAR (interpolated) = 1.09 mW/g

GSM Body 128/Zoom Scan (5x5x7)/Cube 0: Measurement grid: dx=8mm, dy=8mm, dz=5mm
Reference Value = 19.0 V/m; Power Drift = 0.003 dB
Peak SAR (extrapolated) = 1.34 W/kg
SAR(1 g) = 1.02 mW/g; SAR(10 g) = 0.740 mW/g
Maximum value of SAR (measured) = 1.09 mW/g

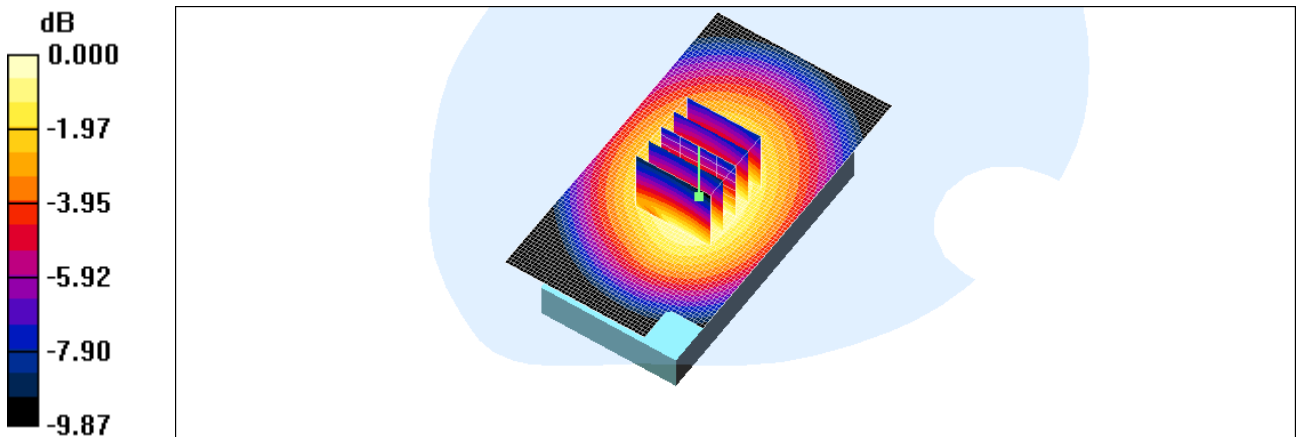

0 dB = 1.09mW/g

Test Laboratory: HCT CO., LTD
EUT Type: GSM/WCDMA Phone with Bluetooth & WLAN
GPRS Class10 and GPRS mode class B(GPRS and GSM, but not simultaneously)
Liquid Temperature: 21.4 °C
Ambient Temperature: 21.6 °C
Test Date: Nov.15, 2010

DUT: P8000; Type: Bar; Serial: #1

Communication System: GSM 850; Frequency: 836.6 MHz; Duty Cycle: 1:4.15
Medium parameters used (interpolated): $f = 836.6$ MHz; $\sigma = 0.983$ mho/m; $\epsilon_r = 56.9$; $\rho = 1000$ kg/m³
Phantom section: Flat Section ; Measurement SW: DASY4, V4.7 Build 80; Postprocessing SW: SEMCAD, V1.8 Build 184

DASY4 Configuration:

- Probe: ES3DV3 - SN3161; ConvF(5.84, 5.84, 5.84); Calibrated: 2010-03-22
- Sensor-Surface: 4mm (Mechanical Surface Detection)
- Electronics: DAE3 Sn446; Calibrated: 2010-09-21
- Phantom: 835/900 Phantom ; Type: SAM

GSM Body 190/Area Scan (51x91x1): Measurement grid: dx=15mm, dy=15mm

[Info: Interpolated medium parameters used for SAR evaluation.](#)

Maximum value of SAR (interpolated) = 1.03 mW/g

GSM Body 190/Zoom Scan (5x5x7)/Cube 0: Measurement grid: dx=8mm, dy=8mm, dz=5mm

Reference Value = 18.4 V/m; Power Drift = -0.007 dB

Peak SAR (extrapolated) = 1.24 W/kg

SAR(1 g) = 0.941 mW/g; SAR(10 g) = 0.684 mW/g

[Info: Interpolated medium parameters used for SAR evaluation.](#)

Maximum value of SAR (measured) = 0.989 mW/g

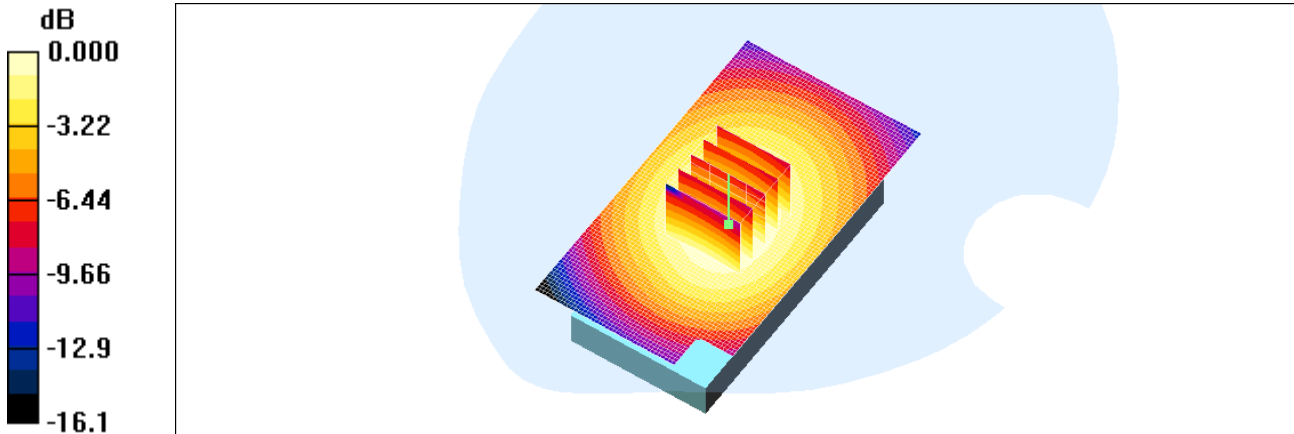

0 dB = 0.989mW/g

Test Laboratory: HCT CO., LTD
EUT Type: GSM/WCDMA Phone with Bluetooth & WLAN
GPRS Class10 and GPRS mode class B(GPRS and GSM, but not simultaneously)
Liquid Temperature: 21.4 °C
Ambient Temperature: 21.6 °C
Test Date: Nov.15, 2010

DUT: P8000; Type: Bar; Serial: #1

Communication System: GSM 850; Frequency: 848.8 MHz; Duty Cycle: 1:4.15
Medium parameters used (interpolated): $f = 848.8$ MHz; $\sigma = 0.993$ mho/m; $\epsilon_r = 56.7$; $\rho = 1000$ kg/m³
Phantom section: Flat Section ; Measurement SW: DASY4, V4.7 Build 80; Postprocessing SW: SEMCAD, V1.8 Build 184

DASY4 Configuration:

- Probe: ES3DV3 - SN3161; ConvF(5.84, 5.84, 5.84); Calibrated: 2010-03-22
- Sensor-Surface: 4mm (Mechanical Surface Detection)
- Electronics: DAE3 Sn446; Calibrated: 2010-09-21
- Phantom: 835/900 Phantom ; Type: SAM

GSM Body 251/Area Scan (51x91x1): Measurement grid: dx=15mm, dy=15mm

[Info: Interpolated medium parameters used for SAR evaluation.](#)

Maximum value of SAR (interpolated) = 0.940 mW/g

GSM Body 251/Zoom Scan (5x5x7)/Cube 0: Measurement grid: dx=8mm, dy=8mm, dz=5mm

Reference Value = 15.6 V/m; Power Drift = -0.017 dB

Peak SAR (extrapolated) = 1.11 W/kg

SAR(1 g) = 0.851 mW/g; SAR(10 g) = 0.617 mW/g

[Info: Interpolated medium parameters used for SAR evaluation.](#)

Maximum value of SAR (measured) = 0.902 mW/g

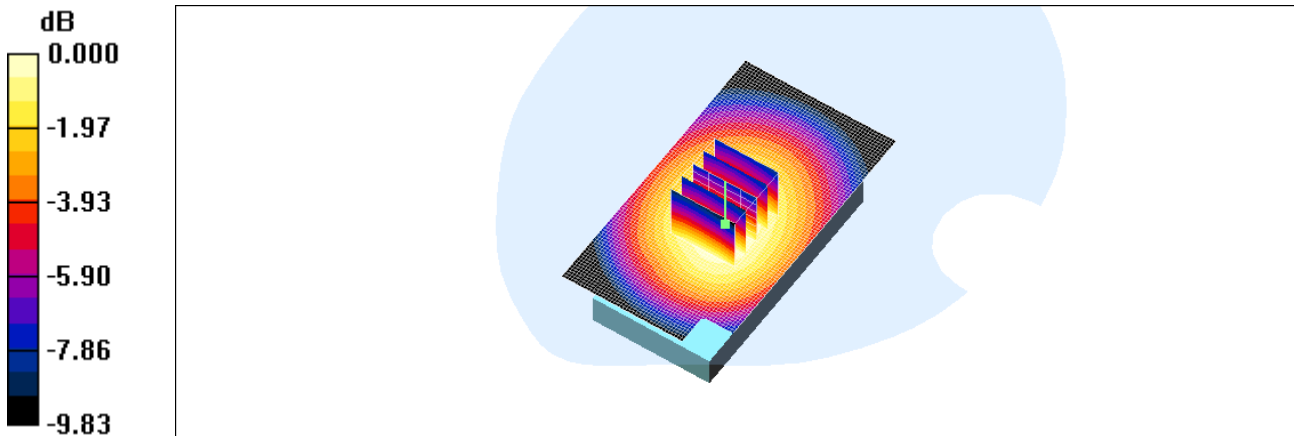

Test Laboratory: HCT CO., LTD
EUT Type: GSM/WCDMA Phone with Bluetooth & WLAN
GPRS Class10 and GPRS mode class B(GPRS and GSM, but not simultaneously)
Liquid Temperature: 21.4 °C
Ambient Temperature: 21.6 °C
Test Date: Nov.15, 2010

DUT: P8000; Type: Bar; Serial: #1

Communication System: GSM 850; Frequency: 836.6 MHz; Duty Cycle: 1:8.3
Medium parameters used (interpolated): $f = 836.6$ MHz; $\sigma = 0.983$ mho/m; $\epsilon_r = 56.9$; $\rho = 1000$ kg/m³
Phantom section: Flat Section ; Measurement SW: DASY4, V4.7 Build 80; Postprocessing SW: SEMCAD, V1.8 Build 184

DASY4 Configuration:

- Probe: ES3DV3 - SN3161; ConvF(5.84, 5.84, 5.84); Calibrated: 2010-03-22
- Sensor-Surface: 4mm (Mechanical Surface Detection)
- Electronics: DAE3 Sn446; Calibrated: 2010-09-21
- Phantom: 835/900 Phantom ; Type: SAM

GSM Body 190/Area Scan (51x91x1): Measurement grid: dx=15mm, dy=15mm

[Info: Interpolated medium parameters used for SAR evaluation.](#)

Maximum value of SAR (interpolated) = 0.502 mW/g

GSM Body 190/Zoom Scan (5x5x7)/Cube 0: Measurement grid: dx=8mm, dy=8mm, dz=5mm

Reference Value = 13.3 V/m; Power Drift = -0.059 dB

Peak SAR (extrapolated) = 0.623 W/kg

SAR(1 g) = 0.473 mW/g; SAR(10 g) = 0.343 mW/g

[Info: Interpolated medium parameters used for SAR evaluation.](#)

Maximum value of SAR (measured) = 0.501 mW/g

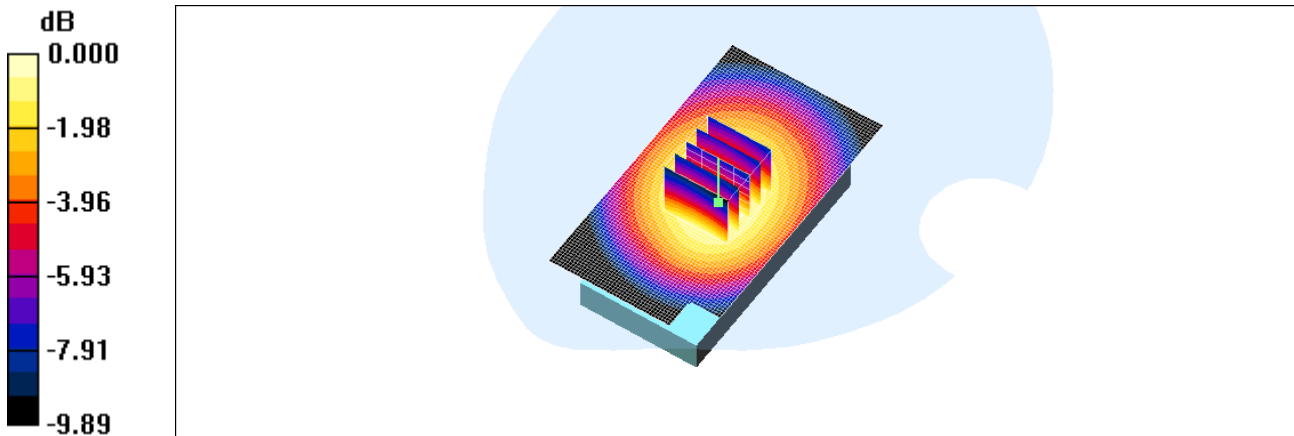

Test Laboratory: HCT CO., LTD
EUT Type: GSM/WCDMA Phone with Bluetooth & WLAN
GPRS Class10 and GPRS mode class B(GPRS and GSM, but not simultaneously)
Liquid Temperature: 21.4 °C
Ambient Temperature: 21.6 °C
Test Date: Nov.15, 2010

DUT: P8000; Type: Bar; Serial: #1

Communication System: GSM 850; Frequency: 836.6 MHz; Duty Cycle: 1:8.3
Medium parameters used (interpolated): $f = 836.6$ MHz; $\sigma = 0.983$ mho/m; $\epsilon_r = 56.9$; $\rho = 1000$ kg/m³
Phantom section: Flat Section ; Measurement SW: DASY4, V4.7 Build 80; Postprocessing SW: SEMCAD, V1.8 Build 184

DASY4 Configuration:

- Probe: ES3DV3 - SN3161; ConvF(5.84, 5.84, 5.84); Calibrated: 2010-03-22
- Sensor-Surface: 4mm (Mechanical Surface Detection)
- Electronics: DAE3 Sn446; Calibrated: 2010-09-21
- Phantom: 835/900 Phantom ; Type: SAM

GSM Body 190/Area Scan (51x91x1): Measurement grid: dx=15mm, dy=15mm

[Info: Interpolated medium parameters used for SAR evaluation.](#)

Maximum value of SAR (interpolated) = 0.497 mW/g

GSM Body 190/Zoom Scan (5x5x7)/Cube 0: Measurement grid: dx=8mm, dy=8mm, dz=5mm

Reference Value = 13.3 V/m; Power Drift = -0.145 dB

Peak SAR (extrapolated) = 0.602 W/kg

SAR(1 g) = 0.462 mW/g; SAR(10 g) = 0.337 mW/g

[Info: Interpolated medium parameters used for SAR evaluation.](#)

Maximum value of SAR (measured) = 0.486 mW/g

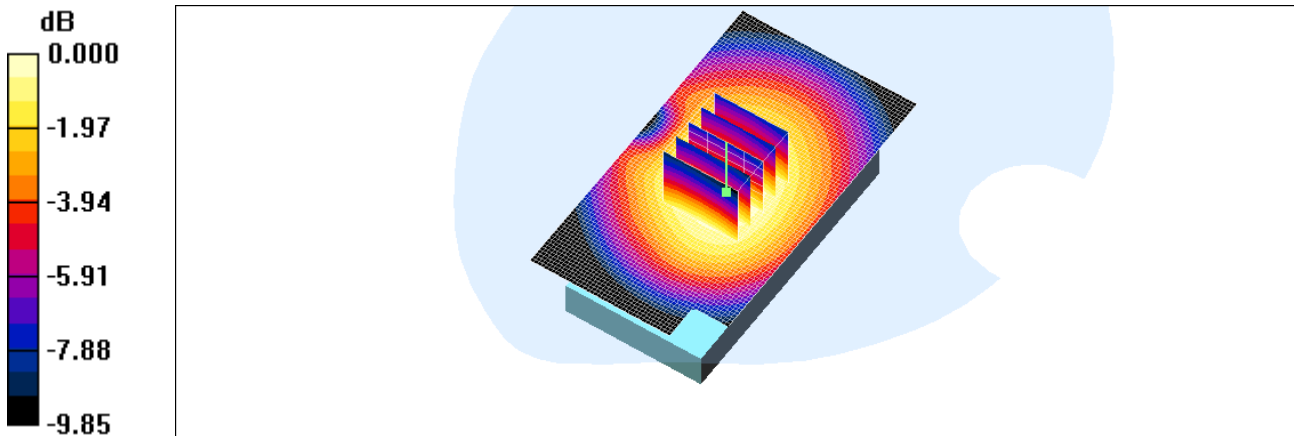

0 dB = 0.486mW/g

Test Laboratory: HCT CO., LTD
EUT Type: GSM/WCDMA Phone with Bluetooth & WLAN
GPRS Class10 and GPRS mode class B(GPRS and GSM, but not simultaneously)
Liquid Temperature: 21.1 °C
Ambient Temperature: 21.3 °C
Test Date: Nov.16, 2010

DUT: P8000; Type: Bar; Serial: #1

Communication System: GSM 1900; Frequency: 1880 MHz; Duty Cycle: 1:4.15
Medium parameters used: $f = 1880 \text{ MHz}$; $\sigma = 1.47 \text{ mho/m}$; $\epsilon_r = 53.7$; $\rho = 1000 \text{ kg/m}^3$
Phantom section: Flat Section ; Measurement SW: DASY4, V4.7 Build 80; Postprocessing SW: SEMCAD, V1.8 Build 184

DASY4 Configuration:

- Probe: ES3DV3 - SN3161; ConvF(4.52, 4.52, 4.52); Calibrated: 2010-03-22
- Sensor-Surface: 4mm (Mechanical Surface Detection)
- Electronics: DAE3 Sn446; Calibrated: 2010-09-21
- Phantom: 1800/1900 Phantom; Type: SAM

GSM Body 661/Area Scan (51x91x1): Measurement grid: dx=15mm, dy=15mm
Maximum value of SAR (interpolated) = 0.627 mW/g

GSM Body 661/Zoom Scan (5x5x7)/Cube 0: Measurement grid: dx=8mm, dy=8mm, dz=5mm
Reference Value = 10.5 V/m; Power Drift = -0.036 dB
Peak SAR (extrapolated) = 0.995 W/kg
SAR(1 g) = 0.585 mW/g; SAR(10 g) = 0.320 mW/g
Maximum value of SAR (measured) = 0.617 mW/g

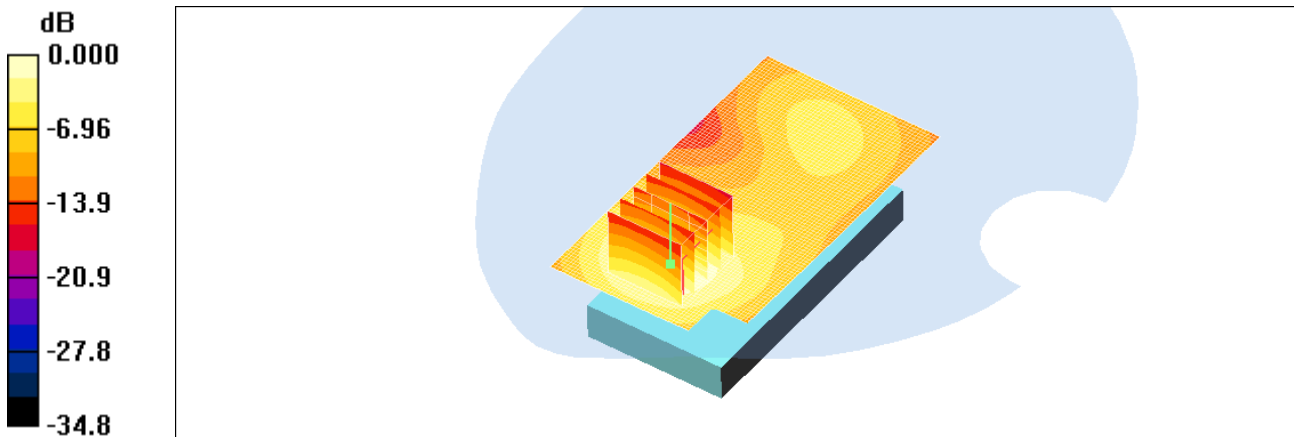

0 dB = 0.617mW/g

Test Laboratory: HCT CO., LTD
 EUT Type: GSM/WCDMA Phone with Bluetooth & WLAN
 GPRS Class10 and GPRS mode class B(GPRS and GSM, but not simultaneously)
 Liquid Temperature: 21.1 °C
 Ambient Temperature: 21.3 °C
 Test Date: Nov.16, 2010

DUT: P8000; Type: Bar; Serial: #1

Communication System: GSM 1900; Frequency: 1880 MHz; Duty Cycle: 1:8.3
 Medium parameters used: $f = 1880 \text{ MHz}$; $\sigma = 1.47 \text{ mho/m}$; $\epsilon_r = 53.7$; $\rho = 1000 \text{ kg/m}^3$
 Phantom section: Flat Section ; Measurement SW: DASY4, V4.7 Build 80; Postprocessing SW: SEMCAD, V1.8 Build 184

DASY4 Configuration:
 - Probe: ES3DV3 - SN3161; ConvF(4.52, 4.52, 4.52); Calibrated: 2010-03-22
 - Sensor-Surface: 4mm (Mechanical Surface Detection)
 - Electronics: DAE3 Sn446; Calibrated: 2010-09-21
 - Phantom: 1800/1900 Phantom; Type: SAM

GSM Body 661/Area Scan (51x91x1): Measurement grid: dx=15mm, dy=15mm
 Maximum value of SAR (interpolated) = 0.318 mW/g

GSM Body 661/Zoom Scan (5x5x7)/Cube 0: Measurement grid: dx=8mm, dy=8mm, dz=5mm
 Reference Value = 7.45 V/m; Power Drift = 0.088 dB
 Peak SAR (extrapolated) = 0.463 W/kg
SAR(1 g) = 0.285 mW/g; SAR(10 g) = 0.162 mW/g
 Maximum value of SAR (measured) = 0.315 mW/g

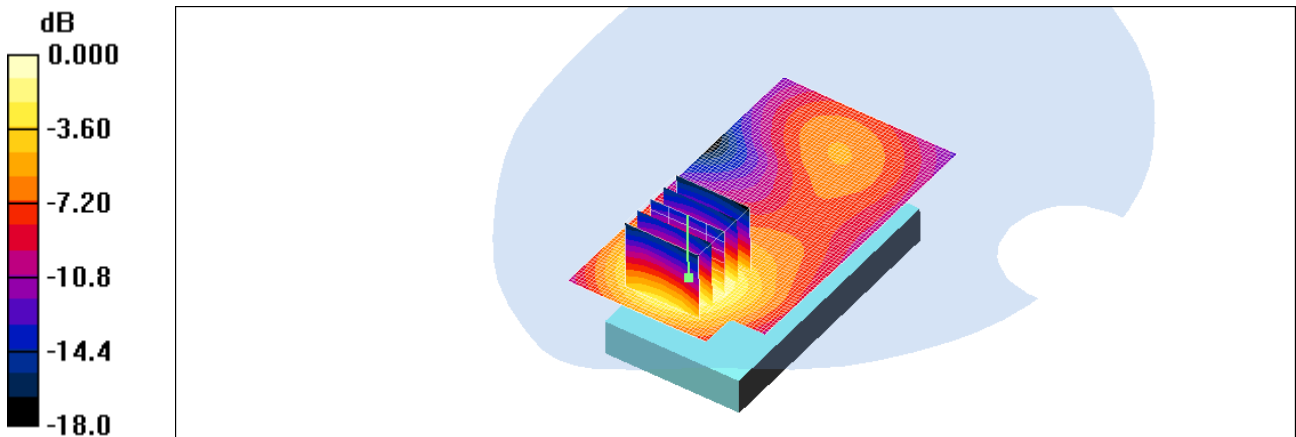

0 dB = 0.315mW/g

Test Laboratory: HCT CO., LTD
EUT Type: GSM/WCDMA Phone with Bluetooth & WLAN
GPRS Class10 and GPRS mode class B(GPRS and GSM, but not simultaneously)
Liquid Temperature: 21.1 °C
Ambient Temperature: 21.3 °C
Test Date: Nov.16, 2010

DUT: P8000; Type: Bar; Serial: #1

Communication System: GSM 1900; Frequency: 1880 MHz; Duty Cycle: 1:8.3
Medium parameters used: $f = 1880$ MHz; $\sigma = 1.47$ mho/m; $\epsilon_r = 53.7$; $\rho = 1000$ kg/m³
Phantom section: Flat Section ; Measurement SW: DASY4, V4.7 Build 80; Postprocessing SW: SEMCAD, V1.8 Build 184

DASY4 Configuration:

- Probe: ES3DV3 - SN3161; ConvF(4.52, 4.52, 4.52); Calibrated: 2010-03-22
- Sensor-Surface: 4mm (Mechanical Surface Detection)
- Electronics: DAE3 Sn446; Calibrated: 2010-09-21
- Phantom: 1800/1900 Phantom; Type: SAM

GSM Body 661/Area Scan (51x91x1): Measurement grid: dx=15mm, dy=15mm
Maximum value of SAR (interpolated) = 0.324 mW/g

GSM Body 661/Zoom Scan (5x5x7)/Cube 0: Measurement grid: dx=8mm, dy=8mm, dz=5mm
Reference Value = 7.50 V/m; Power Drift = -0.002 dB
Peak SAR (extrapolated) = 0.468 W/kg
SAR(1 g) = 0.287 mW/g; SAR(10 g) = 0.163 mW/g
Maximum value of SAR (measured) = 0.318 mW/g

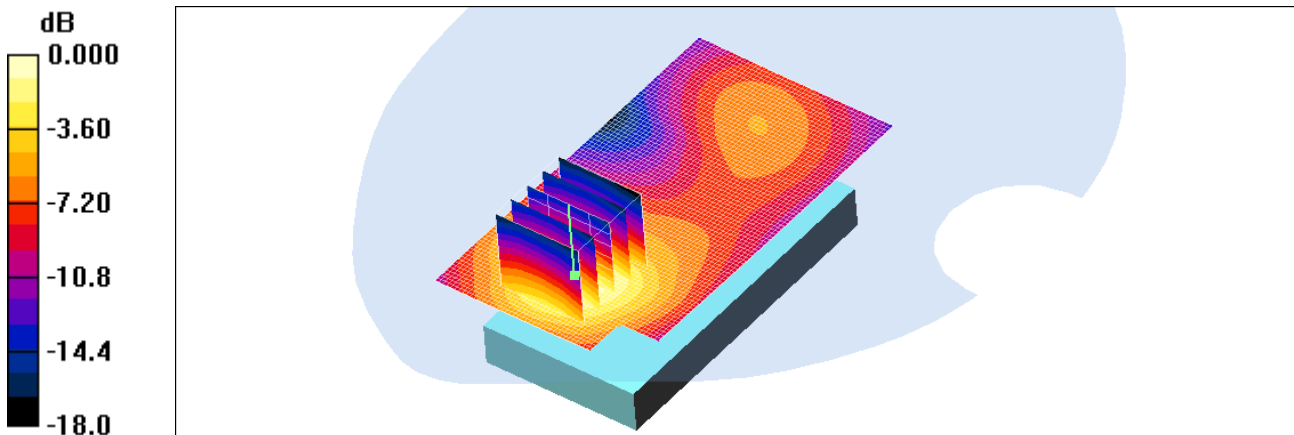

0 dB = 0.318mW/g

Test Laboratory: HCT CO., LTD
EUT Type: GSM/WCDMA Phone with Bluetooth & WLAN
GPRS Class10 and GPRS mode class B(GPRS and GSM, but not simultaneously)
Liquid Temperature: 21.4 °C
Ambient Temperature: 21.6 °C
Test Date: Nov.15, 2010

DUT: P8000; Type: Bar; Serial: #1

Communication System: WCDMA850; Frequency: 836.6 MHz; Duty Cycle: 1:1
Medium parameters used (interpolated): $f = 836.6 \text{ MHz}$; $\sigma = 0.983 \text{ mho/m}$; $\epsilon_r = 56.9$; $\rho = 1000 \text{ kg/m}^3$
Phantom section: Flat Section ; Measurement SW: DASY4, V4.7 Build 80; Postprocessing SW: SEMCAD, V1.8 Build 184

DASY4 Configuration:
- Probe: ES3DV3 - SN3161; ConvF(5.84, 5.84, 5.84); Calibrated: 2010-03-22
- Sensor-Surface: 4mm (Mechanical Surface Detection)
- Electronics: DAE3 Sn446; Calibrated: 2010-09-21
- Phantom: 835/900 Phantom ; Type: SAM

WCDMA Body 4183/Area Scan (51x91x1): Measurement grid: dx=15mm, dy=15mm

[Info: Interpolated medium parameters used for SAR evaluation.](#)
Maximum value of SAR (interpolated) = 0.618 mW/g

WCDMA Body 4183/Zoom Scan (5x5x7)/Cube 0: Measurement grid: dx=8mm, dy=8mm, dz=5mm
Reference Value = 12.6 V/m; Power Drift = 0.105 dB
Peak SAR (extrapolated) = 0.771 W/kg
SAR(1 g) = 0.583 mW/g; SAR(10 g) = 0.421 mW/g

[Info: Interpolated medium parameters used for SAR evaluation.](#)
Maximum value of SAR (measured) = 0.618 mW/g

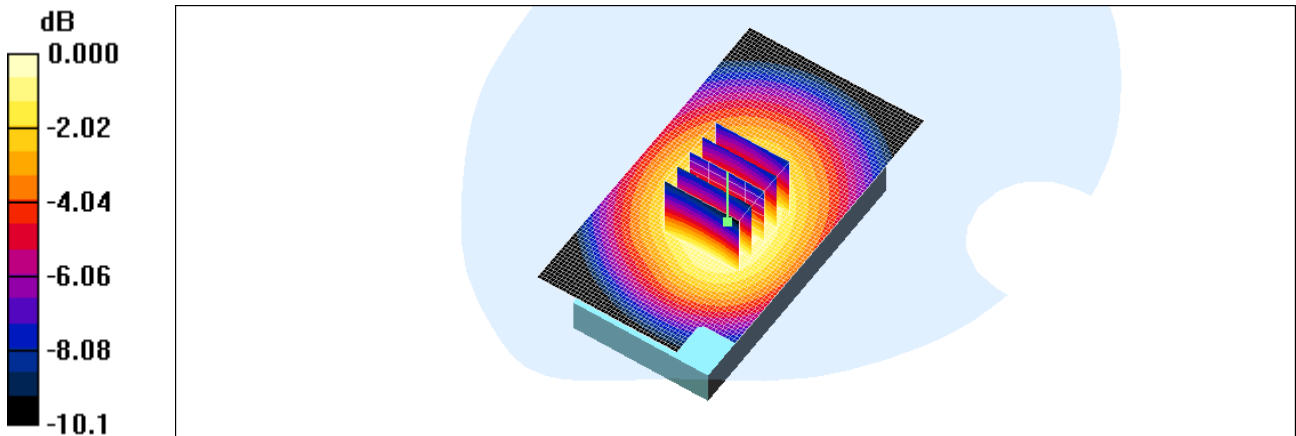

0 dB = 0.618mW/g

Test Laboratory: HCT CO., LTD
EUT Type: GSM/WCDMA Phone with Bluetooth & WLAN
GPRS Class10 and GPRS mode class B(GPRS and GSM, but not simultaneously)
Liquid Temperature: 21.1 °C
Ambient Temperature: 21.3 °C
Test Date: Nov.16, 2010

DUT: P8000; Type: Bar; Serial: #1

Communication System: WCDMA1900(FCC); Frequency: 1880 MHz;Duty Cycle: 1:1
Medium parameters used: $f = 1880$ MHz; $\sigma = 1.47$ mho/m; $\epsilon_r = 53.7$; $\rho = 1000$ kg/m³
Phantom section: Flat Section ; Measurement SW: DASY4, V4.7 Build 80; Postprocessing SW: SEMCAD, V1.8 Build 184

DASY4 Configuration:

- Probe: ES3DV3 - SN3161; ConvF(4.52, 4.52, 4.52); Calibrated: 2010-03-22
- Sensor-Surface: 4mm (Mechanical Surface Detection)
- Electronics: DAE3 Sn446; Calibrated: 2010-09-21
- Phantom: 1800/1900 Phantom; Type: SAM

WCDMA Body 9400/Area Scan (51x91x1): Measurement grid: dx=15mm, dy=15mm
Maximum value of SAR (interpolated) = 0.637 mW/g

WCDMA Body 9400/Zoom Scan (5x5x7)/Cube 0: Measurement grid: dx=8mm, dy=8mm, dz=5mm
Reference Value = 10.4 V/m; Power Drift = 0.127 dB
Peak SAR (extrapolated) = 0.940 W/kg
SAR(1 g) = 0.580 mW/g; SAR(10 g) = 0.331 mW/g
Maximum value of SAR (measured) = 0.643 mW/g

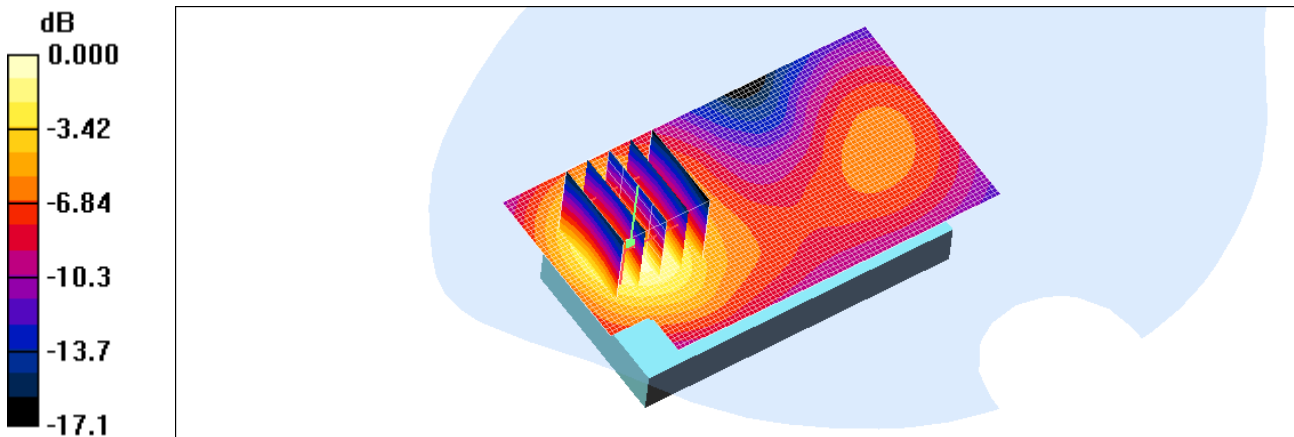

0 dB = 0.643mW/g

Test Laboratory: HCT CO., LTD
EUT Type: GSM/WCDMA Phone with Bluetooth & WLAN
GPRS Class10 and GPRS mode class B(GPRS and GSM, but not simultaneously)
Liquid Temperature: 21.1 °C
Ambient Temperature: 21.3 °C
Test Date: Nov.16, 2010

DUT: P8000; Type: Bar; Serial: #1

Communication System: 2450MHz FCC; Frequency: 2412 MHz;Duty Cycle: 1:1
Medium parameters used (interpolated): $f = 2412$ MHz; $\sigma = 1.89$ mho/m; $\epsilon_r = 52$; $\rho = 1000$ kg/m³
Phantom section: Flat Section ; Measurement SW: DASY4, V4.7 Build 71; Postprocessing SW: SEMCAD, V1.8 Build 184

DASY4 Configuration:

- Probe: ES3DV3 - SN3161; ConvF(4.17, 4.17, 4.17); Calibrated: 2010-03-22
- Sensor-Surface: 4mm (Mechanical Surface Detection)
- Electronics: DAE3 Sn446; Calibrated: 2010-09-21
- Phantom: 1800/1900 Phantom; Type: SAM

802.11b 1ch/Area Scan (51x91x1): Measurement grid: dx=15mm, dy=15mm

[Info: Interpolated medium parameters used for SAR evaluation.](#)

Maximum value of SAR (interpolated) = 0.313 mW/g

802.11b 1ch/Zoom Scan (5x5x7)/Cube 0: Measurement grid: dx=8mm, dy=8mm, dz=5mm

Reference Value = 11.8 V/m; Power Drift = -0.01 dB

Peak SAR (extrapolated) = 0.590 W/kg

SAR(1 g) = 0.290 mW/g; SAR(10 g) = 0.152 mW/g

[Info: Interpolated medium parameters used for SAR evaluation.](#)

Maximum value of SAR (measured) = 0.315 mW/g

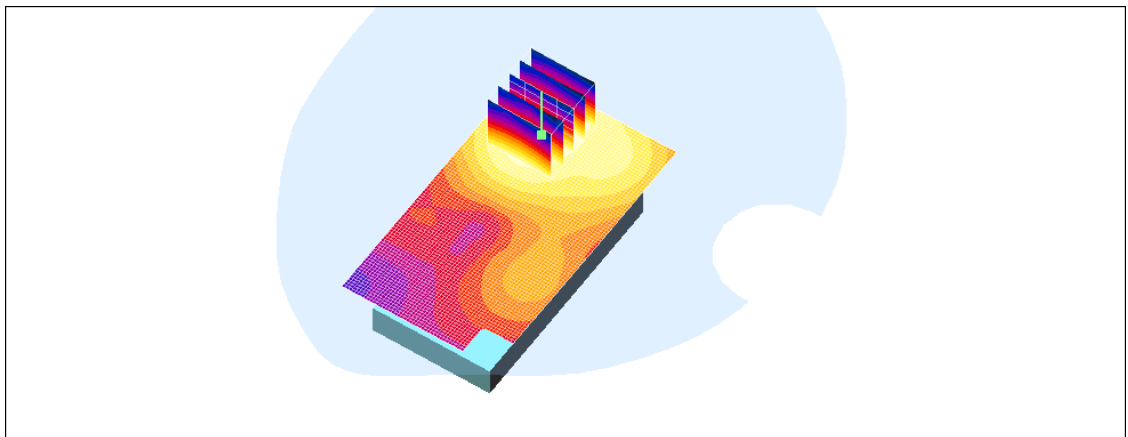
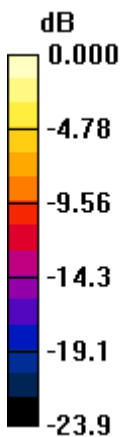

0 dB = 0.315mW/g

Test Laboratory: HCT CO., LTD
EUT Type: GSM/WCDMA Phone with Bluetooth & WLAN
GPRS Class10 and GPRS mode class B(GPRS and GSM, but not simultaneously)
Liquid Temperature: 21.1 °C
Ambient Temperature: 21.3 °C
Test Date: Nov.16, 2010

DUT: P8000; Type: Bar; Serial: #1

Communication System: 2450MHz FCC; Frequency: 2437 MHz;Duty Cycle: 1:1
Medium parameters used (interpolated): $f = 2437$ MHz; $\sigma = 1.95$ mho/m; $\epsilon_r = 51.8$; $\rho = 1000$ kg/m³
Phantom section: Flat Section ; Measurement SW: DASY4, V4.7 Build 71; Postprocessing SW: SEMCAD, V1.8 Build 184

DASY4 Configuration:

- Probe: ES3DV3 - SN3161; ConvF(4.17, 4.17, 4.17); Calibrated: 2010-03-22
- Sensor-Surface: 4mm (Mechanical Surface Detection)
- Electronics: DAE3 Sn446; Calibrated: 2010-09-21
- Phantom: 1800/1900 Phantom; Type: SAM

802.11b 6ch/Area Scan (51x91x1): Measurement grid: dx=15mm, dy=15mm

[Info: Interpolated medium parameters used for SAR evaluation.](#)

Maximum value of SAR (interpolated) = 0.247 mW/g

802.11b 6ch/Zoom Scan (5x5x7)/Cube 0: Measurement grid: dx=8mm, dy=8mm, dz=5mm

Reference Value = 10.2 V/m; Power Drift = 0.03 dB

Peak SAR (extrapolated) = 0.477 W/kg

SAR(1 g) = 0.235 mW/g; SAR(10 g) = 0.125 mW/g

[Info: Interpolated medium parameters used for SAR evaluation.](#)

Maximum value of SAR (measured) = 0.253 mW/g

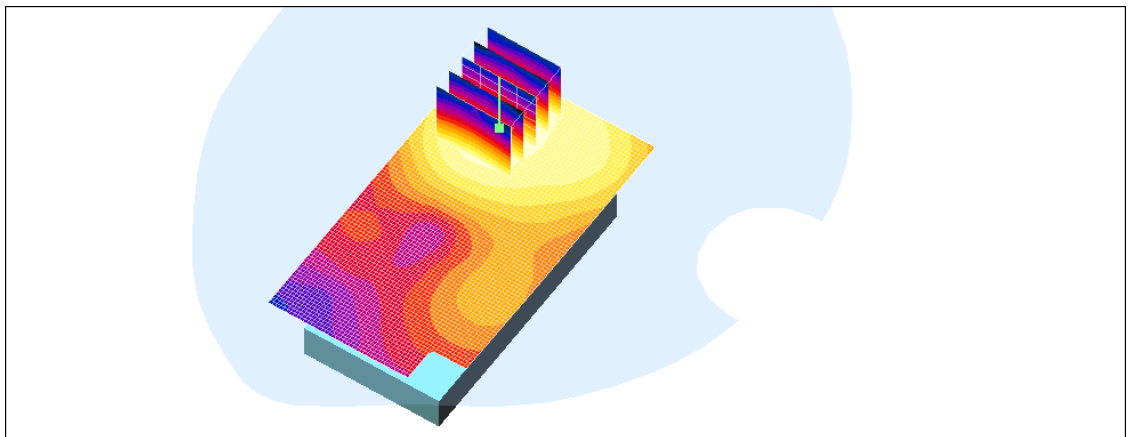
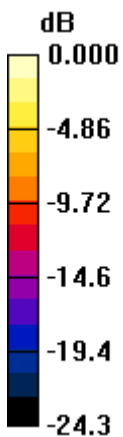

0 dB = 0.253mW/g

Test Laboratory: HCT CO., LTD
EUT Type: GSM/WCDMA Phone with Bluetooth & WLAN
GPRS Class10 and GPRS mode class B(GPRS and GSM, but not simultaneously)
Liquid Temperature: 21.1 °C
Ambient Temperature: 21.3 °C
Test Date: Nov.16, 2010

DUT: P8000; Type: Bar; Serial: #1

Communication System: 2450MHz FCC; Frequency: 2462 MHz;Duty Cycle: 1:1
Medium parameters used (interpolated): $f = 2462$ MHz; $\sigma = 1.98$ mho/m; $\epsilon_r = 51.7$; $\rho = 1000$ kg/m³
Phantom section: Flat Section ; Measurement SW: DASY4, V4.7 Build 71; Postprocessing SW: SEMCAD, V1.8 Build 184

DASY4 Configuration:

- Probe: ES3DV3 - SN3161; ConvF(4.17, 4.17, 4.17); Calibrated: 2010-03-22
- Sensor-Surface: 4mm (Mechanical Surface Detection)
- Electronics: DAE3 Sn446; Calibrated: 2010-09-21
- Phantom: 1800/1900 Phantom; Type: SAM

802.11b 11ch/Area Scan (51x91x1): Measurement grid: dx=15mm, dy=15mm

[Info: Interpolated medium parameters used for SAR evaluation.](#)

Maximum value of SAR (interpolated) = 0.223 mW/g

802.11b 11ch/Zoom Scan (5x5x7)/Cube 0: Measurement grid: dx=8mm, dy=8mm, dz=5mm

Reference Value = 9.60 V/m; Power Drift = 0.020 dB

Peak SAR (extrapolated) = 0.444 W/kg

SAR(1 g) = 0.216 mW/g; SAR(10 g) = 0.115 mW/g

[Info: Interpolated medium parameters used for SAR evaluation.](#)

Maximum value of SAR (measured) = 0.231 mW/g

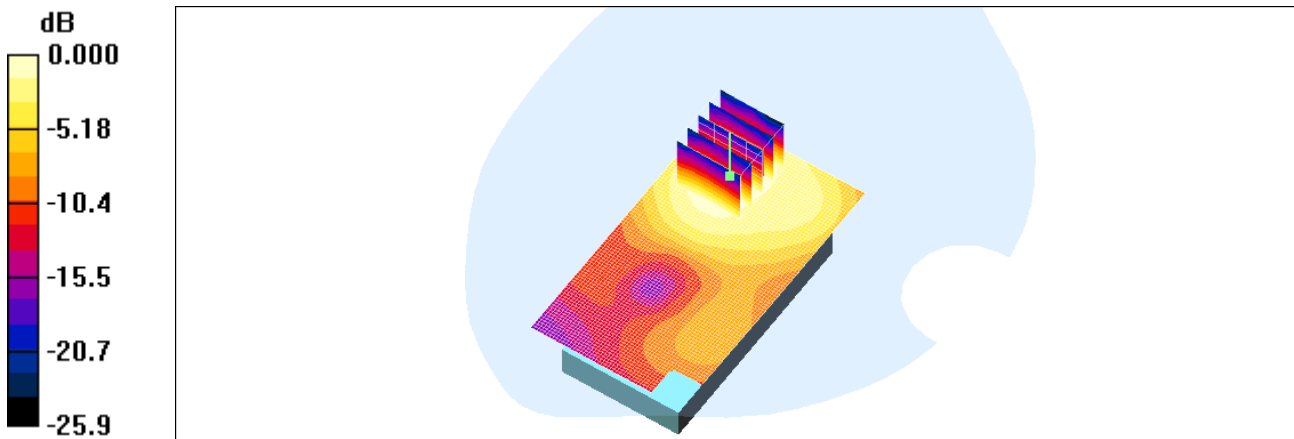

0 dB = 0.231mW/g

Test Laboratory: HCT CO., LTD
 EUT Type: GSM/WCDMA Phone with Bluetooth & WLAN
 GPRS Class10 and GPRS mode class B(GPRS and GSM, but not simultaneously)
 Liquid Temperature: 21.4 °C
 Ambient Temperature: 21.6 °C
 Test Date: Nov.15, 2010

DUT: P8000; Type: Bar; Serial: #1

Communication System: GSM 850; Frequency: 836.6 MHz; Duty Cycle: 1:8.3
 Medium parameters used (interpolated): $f = 836.6$ MHz; $\sigma = 0.891$ mho/m; $\epsilon_r = 42.1$; $\rho = 1000$ kg/m³
 Phantom section: Left Section ; Measurement SW: DASY4, V4.7 Build 80; Postprocessing SW: SEMCAD, V1.8
 Build 184

DASY4 Configuration:
 - Probe: ES3DV3 - SN3161; ConvF(5.96, 5.96, 5.96); Calibrated: 2010-03-22
 - Sensor-Surface: 4mm (Mechanical Surface Detection)
 - Electronics: DAE3 Sn446; Calibrated: 2010-09-21
 - Phantom: 835/900 Phantom ; Type: SAM

Left touch 190/Area Scan (51x91x1): Measurement grid: dx=15mm, dy=15mm

[Info: Interpolated medium parameters used for SAR evaluation.](#)

Maximum value of SAR (interpolated) = 0.426 mW/g

Left touch 190/Zoom Scan (5x5x7)/Cube 0: Measurement grid: dx=8mm, dy=8mm, dz=5mm

Reference Value = 8.99 V/m; Power Drift = -0.139 dB

Peak SAR (extrapolated) = 0.509 W/kg

SAR(1 g) = 0.381 mW/g; SAR(10 g) = 0.276 mW/g

Maximum value of SAR (measured) = 0.404 mW/g

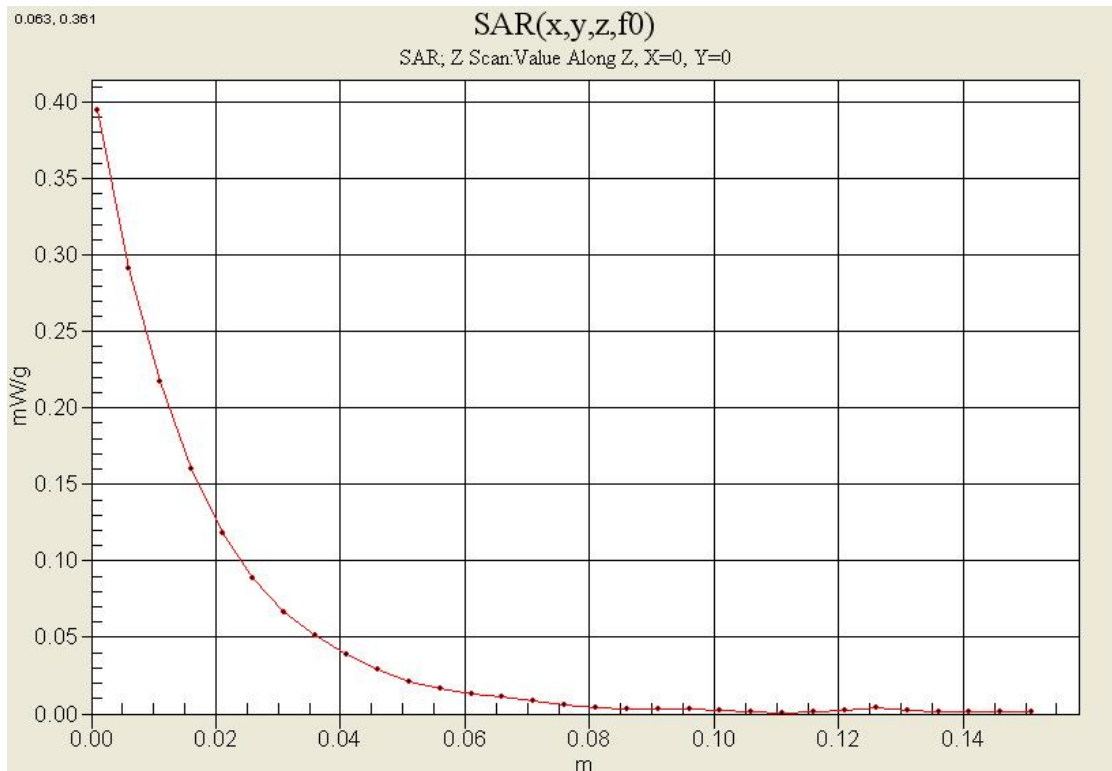

Test Laboratory: HCT CO., LTD
 EUT Type: GSM/WCDMA Phone with Bluetooth & WLAN
 GPRS Class10 and GPRS mode class B(GPRS and GSM, but not simultaneously)
 Liquid Temperature: 21.4 °C
 Ambient Temperature: 21.6 °C
 Test Date: Nov.15, 2010

DUT: P8000; Type: Bar; Serial: #1

Communication System: GSM 850; Frequency: 824.2 MHz; Duty Cycle: 1:4.15
 Medium parameters used: $f = 825$ MHz; $\sigma = 0.974$ mho/m; $\epsilon_r = 56.9$; $\rho = 1000$ kg/m³
 Phantom section: Flat Section ; Measurement SW: DASY4, V4.7 Build 80; Postprocessing SW: SEMCAD, V1.8 Build 184

DASY4 Configuration:
 - Probe: ES3DV3 - SN3161; ConvF(5.84, 5.84, 5.84); Calibrated: 2010-03-22
 - Sensor-Surface: 4mm (Mechanical Surface Detection)
 - Electronics: DAE3 Sn446; Calibrated: 2010-09-21
 - Phantom: 835/900 Phantom ; Type: SAM

GSM Body 128/Area Scan (51x91x1): Measurement grid: dx=15mm, dy=15mm
 Maximum value of SAR (interpolated) = 1.09 mW/g

GSM Body 128/Zoom Scan (5x5x7)/Cube 0: Measurement grid: dx=8mm, dy=8mm, dz=5mm
 Reference Value = 19.0 V/m; Power Drift = 0.003 dB
 Peak SAR (extrapolated) = 1.34 W/kg
SAR(1 g) = 1.02 mW/g; SAR(10 g) = 0.740 mW/g
 Maximum value of SAR (measured) = 1.09 mW/g

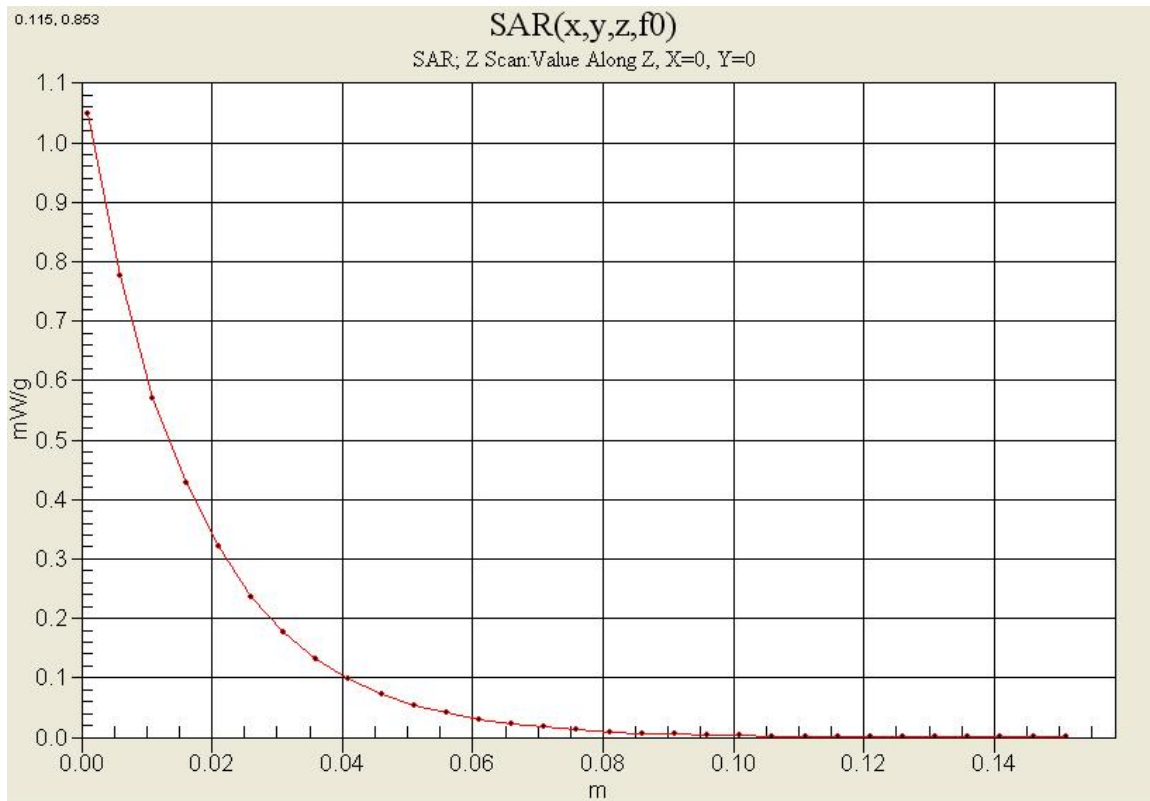

Test Laboratory: HCT CO., LTD
 EUT Type: GSM/WCDMA Phone with Bluetooth & WLAN
 GPRS Class10 and GPRS mode class B(GPRS and GSM, but not simultaneously)
 Liquid Temperature: 21.1 °C
 Ambient Temperature: 21.3 °C
 Test Date: Nov.16, 2010

DUT: P8000; Type: Bar; Serial: #1

Communication System: GSM 1900; Frequency: 1880 MHz; Duty Cycle: 1:8.3
 Medium parameters used: $f = 1880$ MHz; $\sigma = 1.38$ mho/m; $\epsilon_r = 41$; $\rho = 1000$ kg/m³
 Phantom section: Left Section ; Measurement SW: DASY4, V4.7 Build 80; Postprocessing SW: SEMCAD, V1.8 Build 184

DASY4 Configuration:
 - Probe: ES3DV3 - SN3161; ConvF(4.79, 4.79, 4.79); Calibrated: 2010-03-22
 - Sensor-Surface: 4mm (Mechanical Surface Detection)
 - Electronics: DAE3 Sn446; Calibrated: 2010-09-21
 - Phantom: 1800/1900 Phantom; Type: SAM

Left touch 661/Area Scan (51x91x1): Measurement grid: dx=15mm, dy=15mm
 Maximum value of SAR (interpolated) = 0.646 mW/g

Left touch 661/Zoom Scan (5x5x7)/Cube 0: Measurement grid: dx=8mm, dy=8mm, dz=5mm
 Reference Value = 11.0 V/m; Power Drift = -0.068 dB
 Peak SAR (extrapolated) = 0.880 W/kg
SAR(1 g) = 0.567 mW/g; SAR(10 g) = 0.327 mW/g
 Maximum value of SAR (measured) = 0.618 mW/g

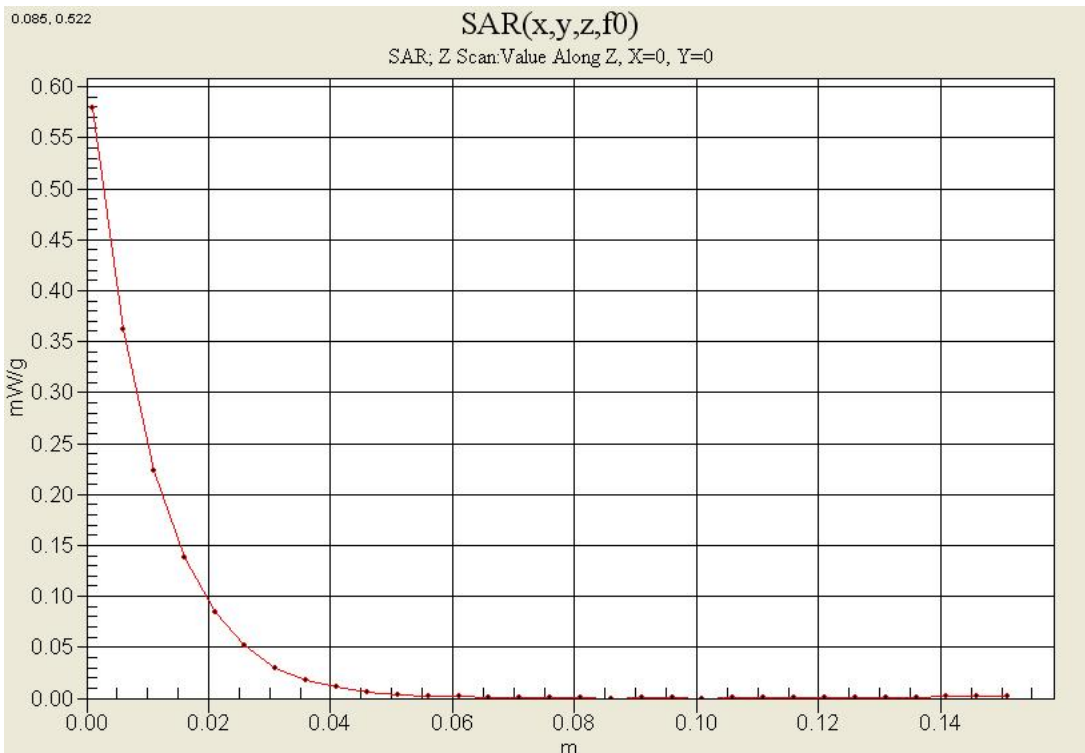

Test Laboratory: HCT CO., LTD
 EUT Type: GSM/WCDMA Phone with Bluetooth & WLAN
 GPRS Class10 and GPRS mode class B(GPRS and GSM, but not simultaneously)
 Liquid Temperature: 21.1 °C
 Ambient Temperature: 21.3 °C
 Test Date: Nov.16, 2010

DUT: P8000; Type: Bar; Serial: #1

Communication System: GSM 1900; Frequency: 1880 MHz; Duty Cycle: 1:4.15
 Medium parameters used: $f = 1880 \text{ MHz}$; $\sigma = 1.47 \text{ mho/m}$; $\epsilon_r = 53.7$; $\rho = 1000 \text{ kg/m}^3$
 Phantom section: Flat Section ; Measurement SW: DASY4, V4.7 Build 80; Postprocessing SW: SEMCAD, V1.8 Build 184

DASY4 Configuration:
 - Probe: ES3DV3 - SN3161; ConvF(4.52, 4.52, 4.52); Calibrated: 2010-03-22
 - Sensor-Surface: 4mm (Mechanical Surface Detection)
 - Electronics: DAE3 Sn446; Calibrated: 2010-09-21
 - Phantom: 1800/1900 Phantom; Type: SAM

GSM Body 661/Area Scan (51x91x1): Measurement grid: dx=15mm, dy=15mm
 Maximum value of SAR (interpolated) = 0.627 mW/g

GSM Body 661/Zoom Scan (5x5x7)/Cube 0: Measurement grid: dx=8mm, dy=8mm, dz=5mm
 Reference Value = 10.5 V/m; Power Drift = -0.036 dB
 Peak SAR (extrapolated) = 0.995 W/kg
SAR(1 g) = 0.585 mW/g; SAR(10 g) = 0.320 mW/g
 Maximum value of SAR (measured) = 0.617 mW/g

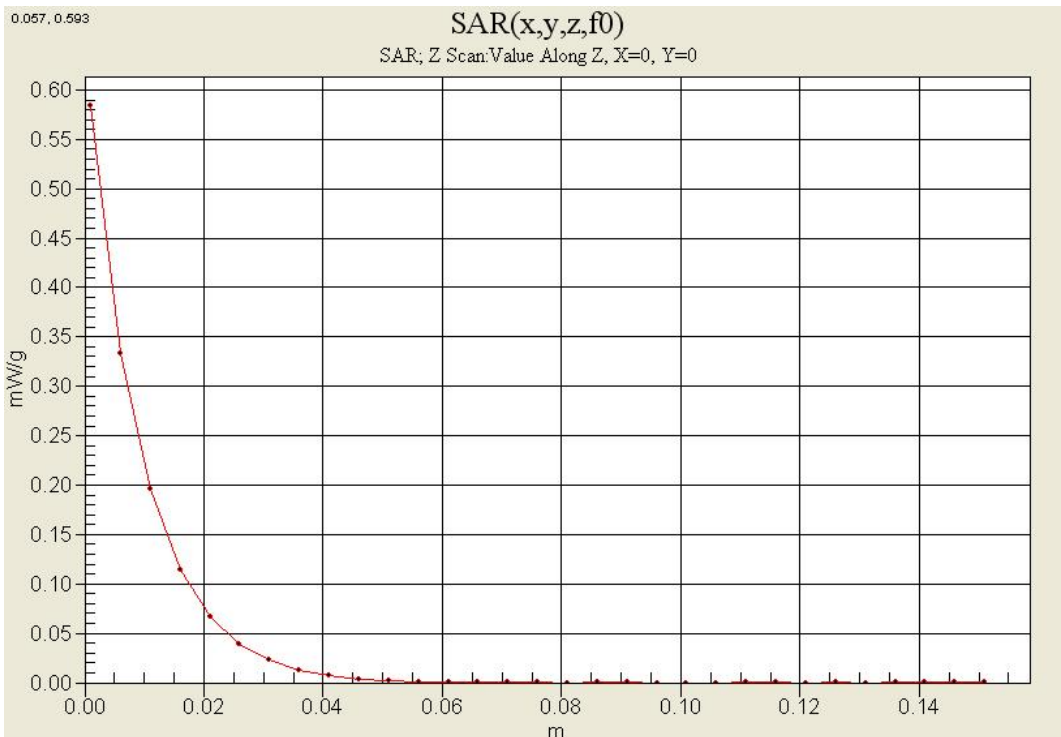

Test Laboratory: HCT CO., LTD
 EUT Type: GSM/WCDMA Phone with Bluetooth & WLAN
 GPRS Class10 and GPRS mode class B(GPRS and GSM, but not simultaneously)
 Liquid Temperature: 21.4 °C
 Ambient Temperature: 21.6 °C
 Test Date: Nov.15, 2010

DUT: P8000; Type: Bar; Serial: #1

Communication System: GSM 1900; Frequency: 1880 MHz; Duty Cycle: 1:8.3
 Medium parameters used: $f = 1880 \text{ MHz}$; $\sigma = 1.38 \text{ mho/m}$; $\epsilon_r = 41$; $\rho = 1000 \text{ kg/m}^3$
 Phantom section: Right Section ; Measurement SW: DASY4, V4.7 Build 80; Postprocessing SW: SEMCAD, V1.8 Build 184

DASY4 Configuration:
 - Probe: ES3DV3 - SN3161; ConvF(4.79, 4.79, 4.79); Calibrated: 2010-03-22
 - Sensor-Surface: 4mm (Mechanical Surface Detection)
 - Electronics: DAE3 Sn446; Calibrated: 2010-09-21
 - Phantom: 1800/1900 Phantom; Type: SAM

Right touch 661/Area Scan (51x91x1): Measurement grid: dx=15mm, dy=15mm
 Maximum value of SAR (interpolated) = 0.389 mW/g

Right touch 661/Zoom Scan (5x5x7)/Cube 0: Measurement grid: dx=8mm, dy=8mm, dz=5mm
 Reference Value = 6.89 V/m; Power Drift = -0.047 dB
 Peak SAR (extrapolated) = 0.521 W/kg
SAR(1 g) = 0.353 mW/g; SAR(10 g) = 0.213 mW/g
 Maximum value of SAR (measured) = 0.391 mW/g

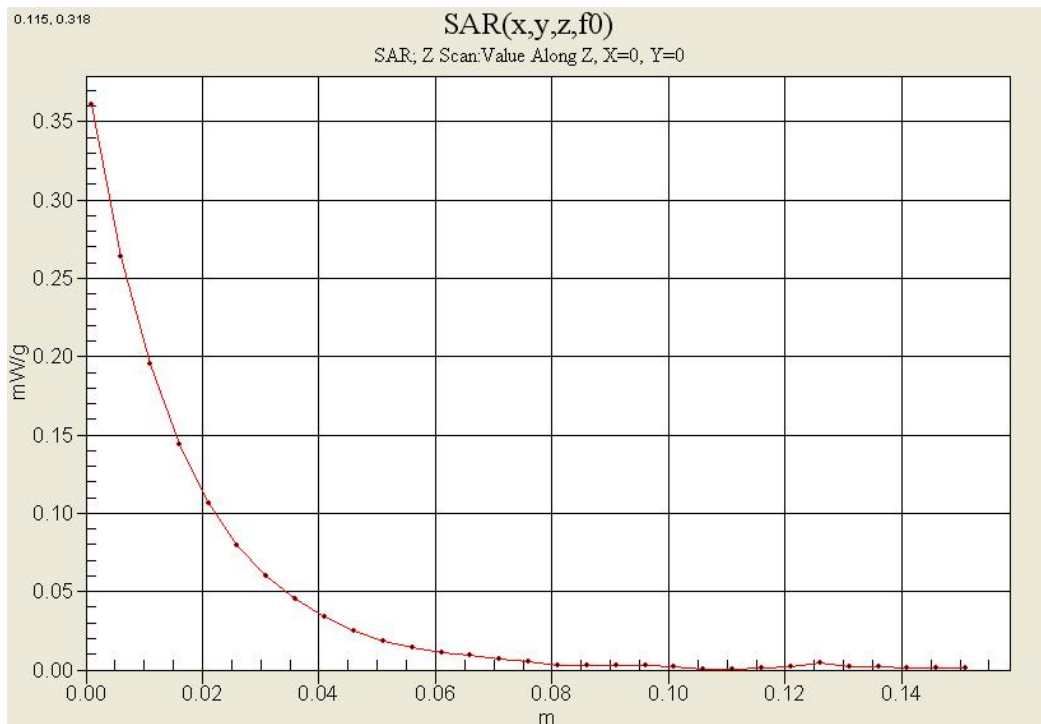

Test Laboratory: HCT CO., LTD
 EUT Type: GSM/WCDMA Phone with Bluetooth & WLAN
 GPRS Class10 and GPRS mode class B(GPRS and GSM, but not simultaneously)
 Liquid Temperature: 21.4 °C
 Ambient Temperature: 21.6 °C
 Test Date: Nov.15, 2010

DUT: P8000; Type: Bar; Serial: #1

Communication System: WCDMA850; Frequency: 836.6 MHz;Duty Cycle: 1:1
 Medium parameters used (interpolated): $f = 836.6$ MHz; $\sigma = 0.983$ mho/m; $\epsilon_r = 56.9$; $\rho = 1000$ kg/m³
 Phantom section: Flat Section ; Measurement SW: DASY4, V4.7 Build 80; Postprocessing SW: SEMCAD, V1.8 Build 184

DASY4 Configuration:
 - Probe: ES3DV3 - SN3161; ConvF(5.84, 5.84, 5.84); Calibrated: 2010-03-22
 - Sensor-Surface: 4mm (Mechanical Surface Detection)
 - Electronics: DAE3 Sn446; Calibrated: 2010-09-21
 - Phantom: 835/900 Phamtom ; Type: SAM

WCDMA Body 4183/Area Scan (51x91x1): Measurement grid: dx=15mm, dy=15mm

[Info: Interpolated medium parameters used for SAR evaluation.](#)
 Maximum value of SAR (interpolated) = 0.618 mW/g

WCDMA Body 4183/Zoom Scan (5x5x7)/Cube 0: Measurement grid: dx=8mm, dy=8mm, dz=5mm
 Reference Value = 12.6 V/m; Power Drift = 0.105 dB
 Peak SAR (extrapolated) = 0.771 W/kg
SAR(1 g) = 0.583 mW/g; SAR(10 g) = 0.421 mW/g

[Info: Interpolated medium parameters used for SAR evaluation.](#)
 Maximum value of SAR (measured) = 0.618 mW/g

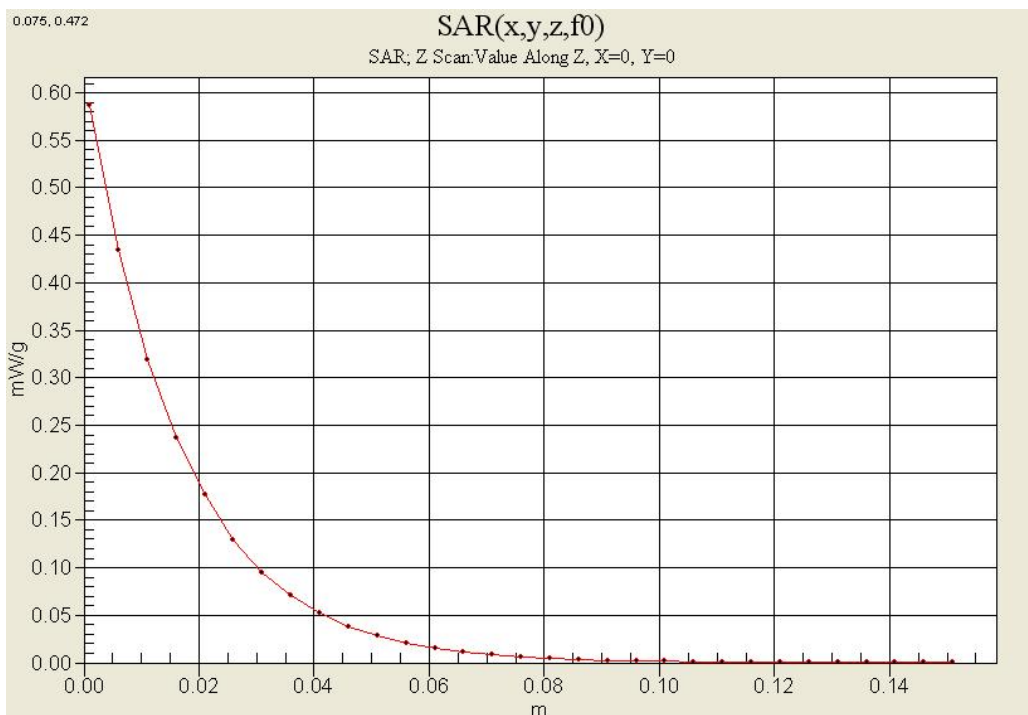

Test Laboratory: HCT CO., LTD
 EUT Type: GSM/WCDMA Phone with Bluetooth & WLAN
 GPRS Class10 and GPRS mode class B(GPRS and GSM, but not simultaneously)
 Liquid Temperature: 21.1 °C
 Ambient Temperature: 21.3 °C
 Test Date: Nov.16, 2010

DUT: P8000; Type: Bar; Serial: #1

Communication System: WCDMA1900(FCC); Frequency: 1907.6 MHz;Duty Cycle: 1:1
 Medium parameters used (interpolated): $f = 1907.6 \text{ MHz}$; $\sigma = 1.4 \text{ mho/m}$; $\epsilon_r = 40.8$; $\rho = 1000 \text{ kg/m}^3$
 Phantom section: Left Section ; Measurement SW: DASY4, V4.7 Build 80; Postprocessing SW: SEMCAD, V1.8 Build 184

DASY4 Configuration:
 - Probe: ES3DV3 - SN3161; ConvF(4.79, 4.79, 4.79); Calibrated: 2010-03-22
 - Sensor-Surface: 4mm (Mechanical Surface Detection)
 - Electronics: DAE3 Sn446; Calibrated: 2010-09-21
 - Phantom: 1800/1900 Phantom; Type: SAM

Left touch 9538/Area Scan (51x91x1): Measurement grid: dx=15mm, dy=15mm

[Info: Interpolated medium parameters used for SAR evaluation.](#)

Maximum value of SAR (interpolated) = 1.32 mW/g

Left touch 9538/Zoom Scan (5x5x7)/Cube 0: Measurement grid: dx=8mm, dy=8mm, dz=5mm

Reference Value = 13.2 V/m; Power Drift = -0.086 dB

Peak SAR (extrapolated) = 1.79 W/kg

SAR(1 g) = 1.16 mW/g; SAR(10 g) = 0.665 mW/g

[Info: Interpolated medium parameters used for SAR evaluation.](#)

Maximum value of SAR (measured) = 1.26 mW/g

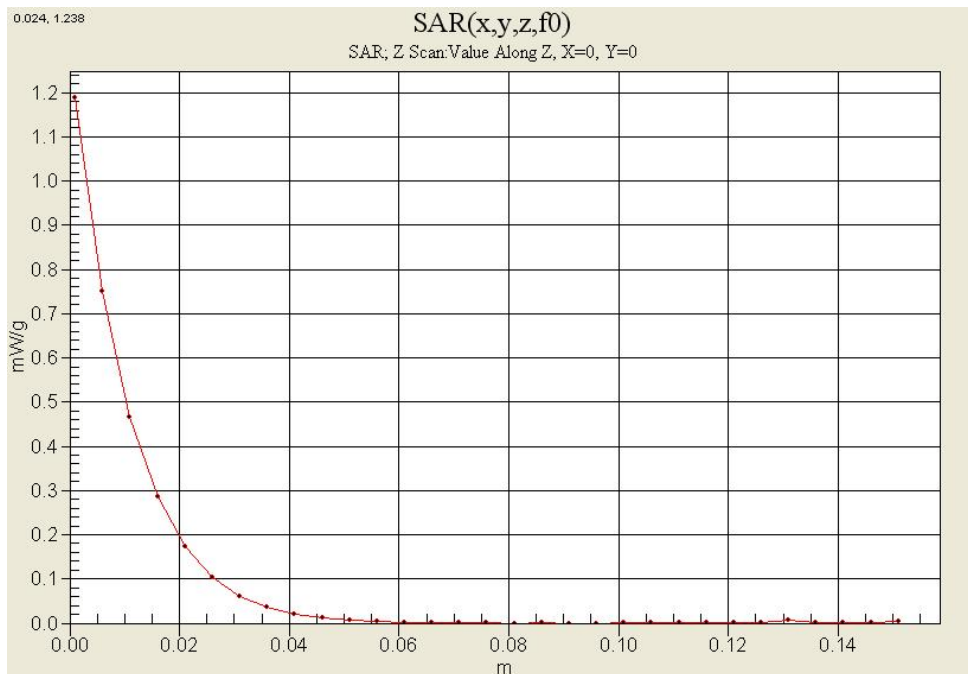

Test Laboratory: HCT CO., LTD
 EUT Type: GSM/WCDMA Phone with Bluetooth & WLAN
 GPRS Class10 and GPRS mode class B(GPRS and GSM, but not simultaneously)
 Liquid Temperature: 21.1 °C
 Ambient Temperature: 21.3 °C
 Test Date: Nov.16, 2010

DUT: P8000; Type: Bar; Serial: #1

Communication System: WCDMA1900(FCC); Frequency: 1880 MHz;Duty Cycle: 1:1
 Medium parameters used: $f = 1880 \text{ MHz}$; $\sigma = 1.47 \text{ mho/m}$; $\epsilon_r = 53.7$; $\rho = 1000 \text{ kg/m}^3$
 Phantom section: Flat Section ; Measurement SW: DASY4, V4.7 Build 80; Postprocessing SW: SEMCAD, V1.8 Build 184

DASY4 Configuration:
 - Probe: ES3DV3 - SN3161; ConvF(4.52, 4.52, 4.52); Calibrated: 2010-03-22
 - Sensor-Surface: 4mm (Mechanical Surface Detection)
 - Electronics: DAE3 Sn446; Calibrated: 2010-09-21
 - Phantom: 1800/1900 Phantom; Type: SAM

WCDMA Body 9400/Area Scan (51x91x1): Measurement grid: dx=15mm, dy=15mm
 Maximum value of SAR (interpolated) = 0.637 mW/g

WCDMA Body 9400/Zoom Scan (5x5x7)/Cube 0: Measurement grid: dx=8mm, dy=8mm, dz=5mm
 Reference Value = 10.4 V/m; Power Drift = 0.127 dB
 Peak SAR (extrapolated) = 0.940 W/kg
SAR(1 g) = 0.580 mW/g; SAR(10 g) = 0.331 mW/g
 Maximum value of SAR (measured) = 0.643 mW/g

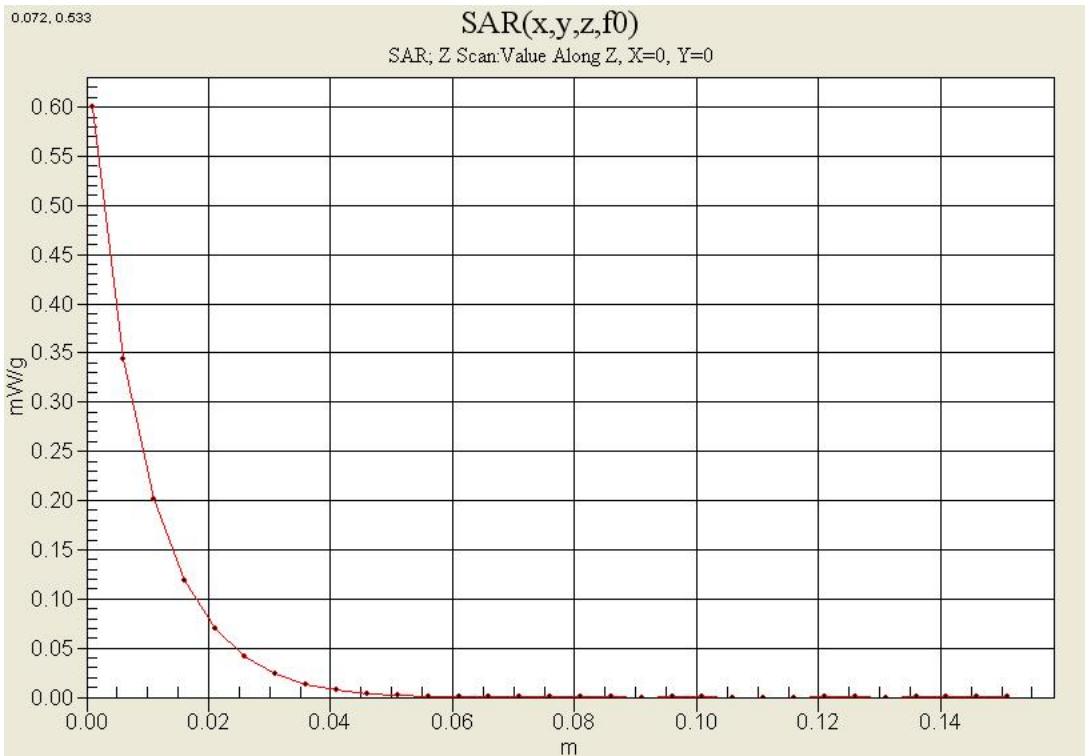

Test Laboratory: HCT CO., LTD
 EUT Type: GSM/WCDMA Phone with Bluetooth & WLAN
 GPRS Class10 and GPRS mode class B(GPRS and GSM, but not simultaneously)
 Liquid Temperature: 21.1 °C
 Ambient Temperature: 21.3 °C
 Test Date: Nov.16, 2010

DUT: P8000; Type: Bar; Serial: #1

Communication System: 2450MHz FCC; Frequency: 2437 MHz;Duty Cycle: 1:1
 Medium parameters used (interpolated): $f = 2437$ MHz; $\sigma = 1.84$ mho/m; $\epsilon_r = 38.3$; $\rho = 1000$ kg/m³
 Phantom section: Right Section ; Measurement SW: DASY4, V4.7 Build 80; Postprocessing SW: SEMCAD, V1.8 Build 184

- DASY4 Configuration:
- Probe: ES3DV3 - SN3161; ConvF(4.26, 4.26, 4.26); Calibrated: 2010-03-22
 - Sensor-Surface: 4mm (Mechanical Surface Detection)
 - Electronics: DAE3 Sn446; Calibrated: 2010-09-21
 - Phantom: 1800/1900 Phantom; Type: SAM

Right tilt 6/Area Scan (51x91x1): Measurement grid: dx=15mm, dy=15mm

[Info: Interpolated medium parameters used for SAR evaluation.](#)

Maximum value of SAR (interpolated) = 0.804 mW/g

Right tilt 6/Zoom Scan (5x5x7)/Cube 0: Measurement grid: dx=8mm, dy=8mm, dz=5mm

Reference Value = 19.1 V/m; Power Drift = 0.023 dB

Peak SAR (extrapolated) = 1.93 W/kg

SAR(1 g) = 0.768 mW/g; SAR(10 g) = 0.356 mW/g

[Info: Interpolated medium parameters used for SAR evaluation.](#)

Maximum value of SAR (measured) = 0.833 mW/g

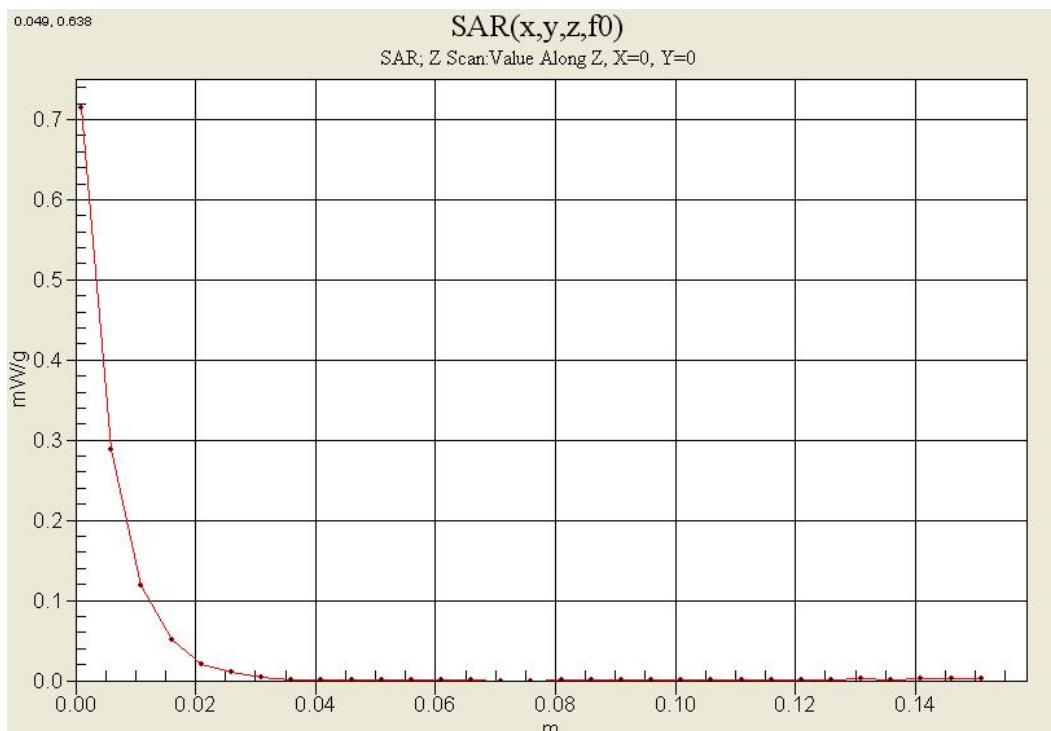

Test Laboratory: HCT CO., LTD
 EUT Type: GSM/WCDMA Phone with Bluetooth & WLAN
 GPRS Class10 and GPRS mode class B(GPRS and GSM, but not simultaneously)
 Liquid Temperature: 21.2 °C
 Ambient Temperature: 21.4 °C
 Test Date: Mar.20, 2011

DUT: P8000; Type: Bar; Serial: #1

Communication System: GSM 850; Frequency: 836.6 MHz;Duty Cycle: 1:4.15
 Medium parameters used (interpolated): $f = 836.6 \text{ MHz}$; $\sigma = 0.982 \text{ mho/m}$; $\epsilon_r = 56.8$; $\rho = 1000 \text{ kg/m}^3$
 Phantom section: Flat Section ; Measurement SW: DASY4, V4.7 Build 80; Postprocessing SW: SEMCAD, V1.8 Build 184

DASY4 Configuration:
 - Probe: ET3DV6 - SN1630; ConvF(6.17, 6.17, 6.17); Calibrated: 2010-05-25
 - Sensor-Surface: 4mm (Mechanical Surface Detection)
 - Electronics: DAE4 Sn869; Calibrated: 2010-09-21
 - Phantom: 835/900 Phamtom ; Type: SAM

GSM Body 190/Area Scan (61x91x1): Measurement grid: dx=15mm, dy=15mm

[Info: Interpolated medium parameters used for SAR evaluation.](#)
 Maximum value of SAR (interpolated) = 0.528 mW/g

GSM Body 190/Zoom Scan (5x5x7)/Cube 0: Measurement grid: dx=8mm, dy=8mm, dz=5mm
 Reference Value = 12.0 V/m; Power Drift = -0.124 dB
 Peak SAR (extrapolated) = 0.615 W/kg
SAR(1 g) = 0.491 mW/g; SAR(10 g) = 0.361 mW/g

[Info: Interpolated medium parameters used for SAR evaluation.](#)
 Maximum value of SAR (measured) = 0.520 mW/g

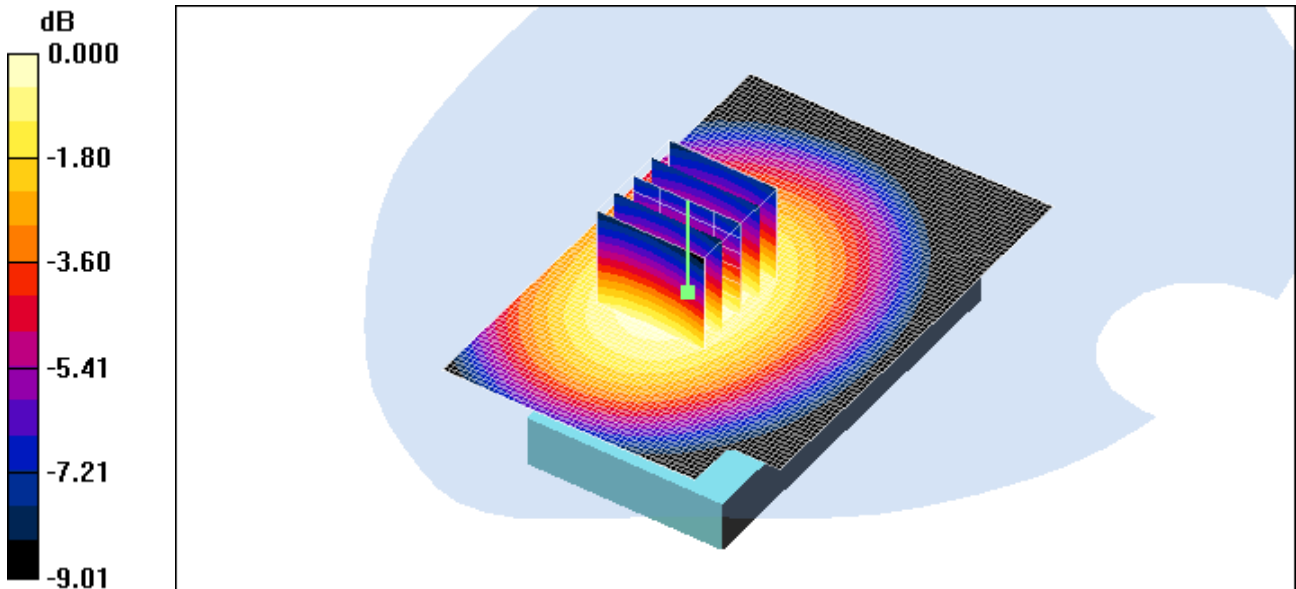

0 dB = 0.520mW/g

Test Laboratory: HCT CO., LTD
 EUT Type: GSM/WCDMA Phone with Bluetooth & WLAN
 GPRS Class10 and GPRS mode class B(GPRS and GSM, but not simultaneously)
 Liquid Temperature: 21.2 °C
 Ambient Temperature: 21.4 °C
 Test Date: Mar.20, 2011

DUT: P8000; Type: Bar; Serial: #1

Communication System: GSM 850; Frequency: 824.2 MHz; Duty Cycle: 1:4.15
 Medium parameters used: $f = 825 \text{ MHz}$; $\sigma = 0.971 \text{ mho/m}$; $\epsilon_r = 56.9$; $\rho = 1000 \text{ kg/m}^3$
 Phantom section: Flat Section ; Measurement SW: DASY4, V4.7 Build 80; Postprocessing SW: SEMCAD, V1.8 Build 184

DASY4 Configuration:
 - Probe: ET3DV6 - SN1630; ConvF(6.17, 6.17, 6.17); Calibrated: 2010-05-25
 - Sensor-Surface: 4mm (Mechanical Surface Detection)
 - Electronics: DAE4 Sn869; Calibrated: 2010-09-21
 - Phantom: 835/900 Phantom ; Type: SAM

GSM Body 128/Area Scan (61x91x1): Measurement grid: dx=15mm, dy=15mm
 Maximum value of SAR (interpolated) = 1.35 mW/g

GSM Body 128/Zoom Scan (5x5x7)/Cube 0: Measurement grid: dx=8mm, dy=8mm, dz=5mm
 Reference Value = 16.4 V/m; Power Drift = 0.005 dB
 Peak SAR (extrapolated) = 1.56 W/kg
SAR(1 g) = 1.24 mW/g; SAR(10 g) = 0.909 mW/g
 Maximum value of SAR (measured) = 1.31 mW/g

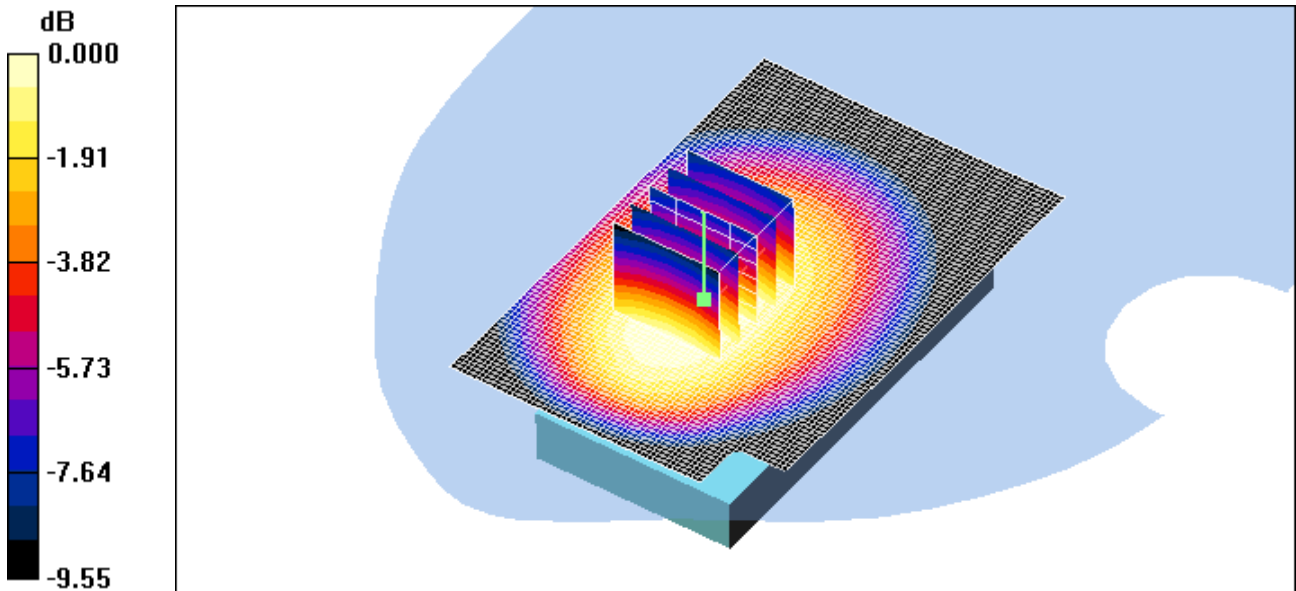

0 dB = 1.31mW/g

Test Laboratory: HCT CO., LTD
 EUT Type: GSM/WCDMA Phone with Bluetooth & WLAN
 GPRS Class10 and GPRS mode class B(GPRS and GSM, but not simultaneously)
 Liquid Temperature: 21.2 °C
 Ambient Temperature: 21.4 °C
 Test Date: Mar.20, 2011

DUT: P8000; Type: Bar; Serial: #1

Communication System: GSM 850; Frequency: 836.6 MHz;Duty Cycle: 1:4.15
 Medium parameters used (interpolated): $f = 836.6 \text{ MHz}$; $\sigma = 0.982 \text{ mho/m}$; $\epsilon_r = 56.8$; $\rho = 1000 \text{ kg/m}^3$
 Phantom section: Flat Section ; Measurement SW: DASY4, V4.7 Build 80; Postprocessing SW: SEMCAD, V1.8 Build 184

DASY4 Configuration:
 - Probe: ET3DV6 - SN1630; ConvF(6.17, 6.17, 6.17); Calibrated: 2010-05-25
 - Sensor-Surface: 4mm (Mechanical Surface Detection)
 - Electronics: DAE4 Sn869; Calibrated: 2010-09-21
 - Phantom: 835/900 Phantom ; Type: SAM

GSM Body 190/Area Scan (61x91x1): Measurement grid: dx=15mm, dy=15mm

[Info: Interpolated medium parameters used for SAR evaluation.](#)
 Maximum value of SAR (interpolated) = 1.19 mW/g

GSM Body 190/Zoom Scan (5x5x7)/Cube 0: Measurement grid: dx=8mm, dy=8mm, dz=5mm
 Reference Value = 15.5 V/m; Power Drift = -0.036 dB
 Peak SAR (extrapolated) = 1.38 W/kg
SAR(1 g) = 1.1 mW/g; SAR(10 g) = 0.801 mW/g

[Info: Interpolated medium parameters used for SAR evaluation.](#)
 Maximum value of SAR (measured) = 1.16 mW/g

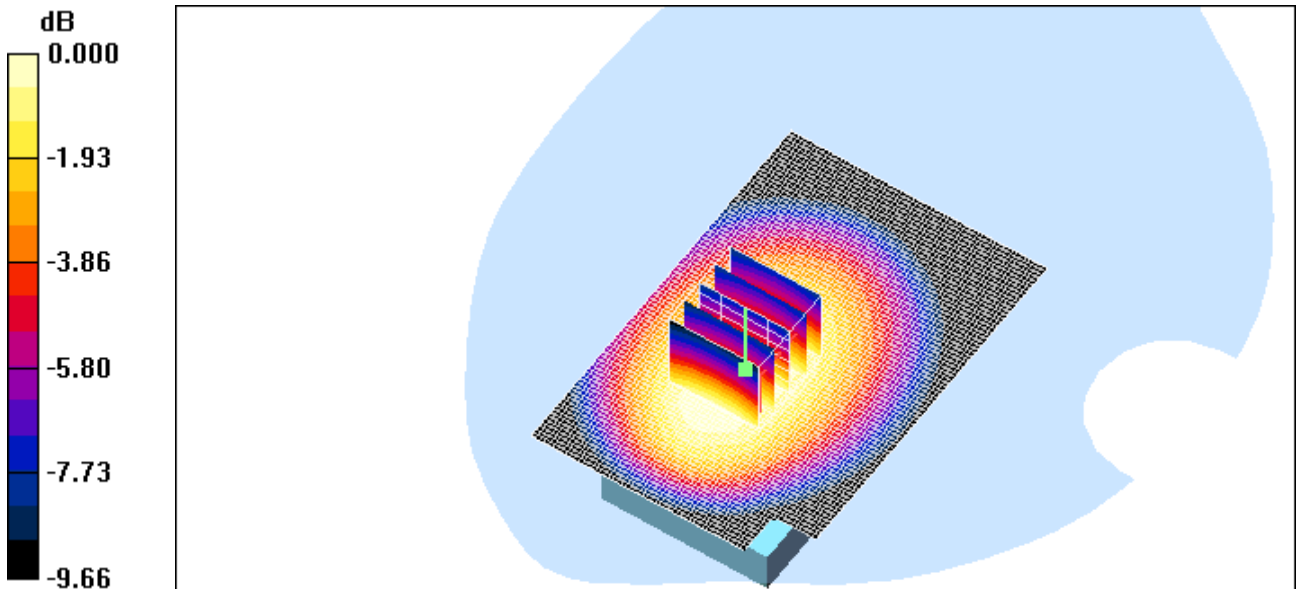

0 dB = 1.16mW/g

Test Laboratory: HCT CO., LTD
EUT Type: GSM/WCDMA Phone with Bluetooth & WLAN
GPRS Class10 and GPRS mode class B(GPRS and GSM, but not simultaneously)
Liquid Temperature: 21.2 °C
Ambient Temperature: 21.4 °C
Test Date: Mar.20, 2011

DUT: P8000; Type: Bar; Serial: #1

Communication System: GSM 850; Frequency: 848.8 MHz; Duty Cycle: 1:4.15
Medium parameters used (interpolated): $f = 848.8 \text{ MHz}$; $\sigma = 0.991 \text{ mho/m}$; $\epsilon_r = 56.7$; $\rho = 1000 \text{ kg/m}^3$
Phantom section: Flat Section ; Measurement SW: DASY4, V4.7 Build 80; Postprocessing SW: SEMCAD, V1.8 Build 184

DASY4 Configuration:

- Probe: ET3DV6 - SN1630; ConvF(6.17, 6.17, 6.17); Calibrated: 2010-05-25
- Sensor-Surface: 4mm (Mechanical Surface Detection)
- Electronics: DAE4 Sn869; Calibrated: 2010-09-21
- Phantom: 835/900 Phantom ; Type: SAM

GSM Body 251/Zoom Scan (5x5x7)/Cube 0: Measurement grid: $dx=8\text{mm}$, $dy=8\text{mm}$, $dz=5\text{mm}$
Reference Value = 14.9 V/m; Power Drift = 0.028 dB
Peak SAR (extrapolated) = 1.31 W/kg
SAR(1 g) = 1.03 mW/g; SAR(10 g) = 0.753 mW/g

[Info: Interpolated medium parameters used for SAR evaluation.](#)

Maximum value of SAR (measured) = 1.08 mW/g

GSM Body 251/Area Scan (61x91x1): Measurement grid: $dx=15\text{mm}$, $dy=15\text{mm}$

[Info: Interpolated medium parameters used for SAR evaluation.](#)

Maximum value of SAR (interpolated) = 1.11 mW/g

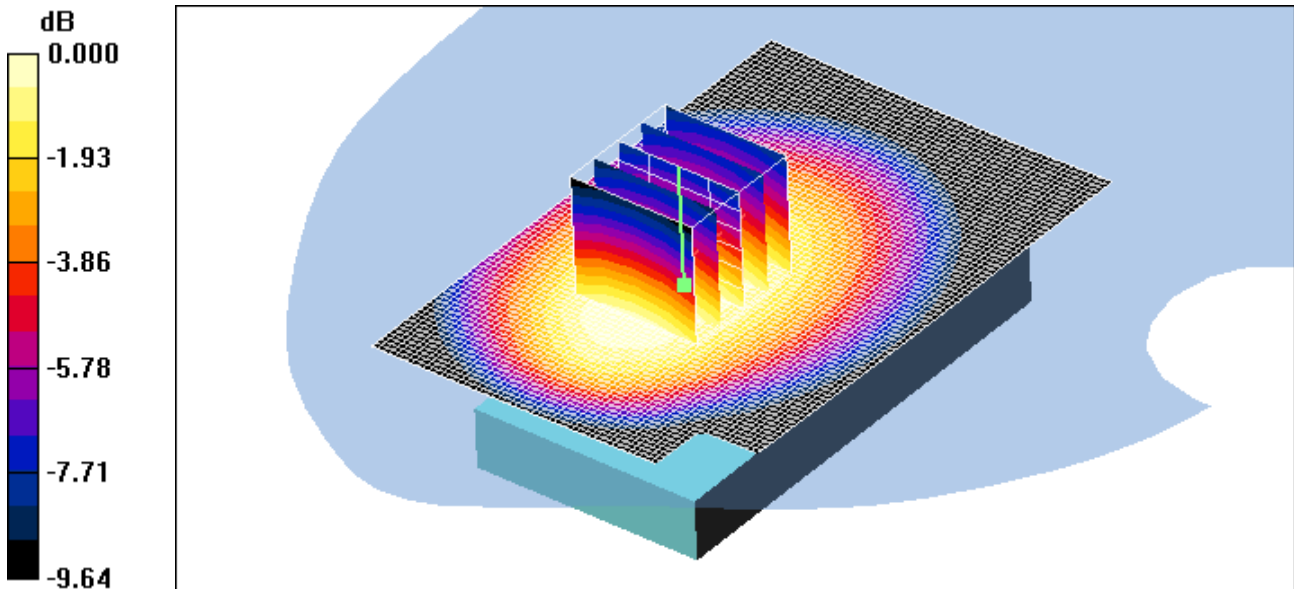

0 dB = 1.08mW/g

Test Laboratory: HCT CO., LTD
EUT Type: GSM/WCDMA Phone with Bluetooth & WLAN
GPRS Class10 and GPRS mode class B(GPRS and GSM, but not simultaneously)
Liquid Temperature: 21.2 °C
Ambient Temperature: 21.4 °C
Test Date: Mar.20, 2011

DUT: P8000; Type: Bar side; Serial: #1

Communication System: GSM 850; Frequency: 836.6 MHz; Duty Cycle: 1:4.15
Medium parameters used (interpolated): $f = 836.6$ MHz; $\sigma = 0.982$ mho/m; $\epsilon_r = 56.8$; $\rho = 1000$ kg/m³
Phantom section: Flat Section ; Measurement SW: DASY4, V4.7 Build 80; Postprocessing SW: SEMCAD, V1.8 Build 184

DASY4 Configuration:

- Probe: ET3DV6 - SN1630; ConvF(6.17, 6.17, 6.17); Calibrated: 2010-05-25
- Sensor-Surface: 4mm (Mechanical Surface Detection)
- Electronics: DAE4 Sn869; Calibrated: 2010-09-21
- Phantom: 835/900 Phantom ; Type: SAM

Body 190ch/Area Scan (31x101x1): Measurement grid: dx=15mm, dy=15mm

[Info: Interpolated medium parameters used for SAR evaluation.](#)

Maximum value of SAR (interpolated) = 0.692 mW/g

Body 190ch/Zoom Scan (5x5x7)/Cube 0: Measurement grid: dx=8mm, dy=8mm, dz=5mm

Reference Value = 13.3 V/m; Power Drift = 0.038 dB

Peak SAR (extrapolated) = 0.885 W/kg

SAR(1 g) = 0.646 mW/g; SAR(10 g) = 0.448 mW/g

[Info: Interpolated medium parameters used for SAR evaluation.](#)

Maximum value of SAR (measured) = 0.688 mW/g

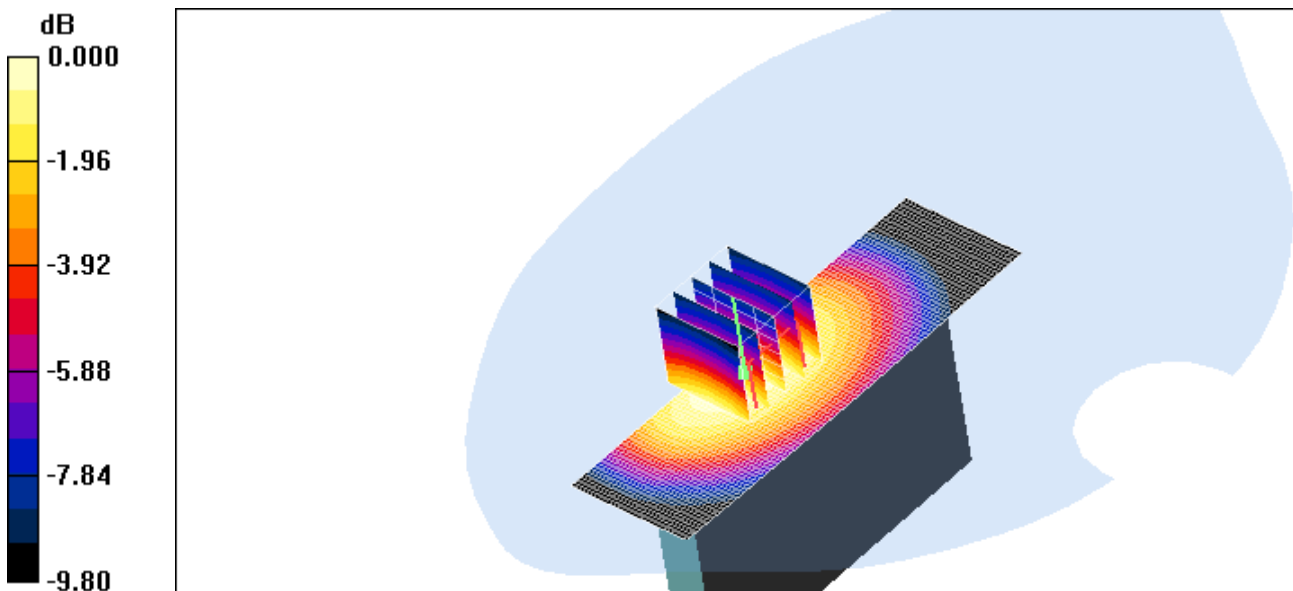

0 dB = 0.688mW/g

Test Laboratory: HCT CO., LTD
 EUT Type: GSM/WCDMA Phone with Bluetooth & WLAN
 GPRS Class10 and GPRS mode class B(GPRS and GSM, but not simultaneously)
 Liquid Temperature: 21.2 °C
 Ambient Temperature: 21.4 °C
 Test Date: Mar.20, 2011

DUT: P8000; Type: Bar side; Serial: #1

Communication System: GSM 850; Frequency: 836.6 MHz; Duty Cycle: 1:4.15
 Medium parameters used (interpolated): $f = 836.6 \text{ MHz}$; $\sigma = 0.982 \text{ mho/m}$; $\epsilon_r = 56.8$; $\rho = 1000 \text{ kg/m}^3$
 Phantom section: Flat Section ; Measurement SW: DASY4, V4.7 Build 80; Postprocessing SW: SEMCAD, V1.8 Build 184

DASY4 Configuration:
 - Probe: ET3DV6 - SN1630; ConvF(6.17, 6.17, 6.17); Calibrated: 2010-05-25
 - Sensor-Surface: 4mm (Mechanical Surface Detection)
 - Electronics: DAE4 Sn869; Calibrated: 2010-09-21
 - Phantom: 835/900 Phantom ; Type: SAM

Body 190ch/Area Scan (31x101x1): Measurement grid: dx=15mm, dy=15mm

[Info: Interpolated medium parameters used for SAR evaluation.](#)
 Maximum value of SAR (interpolated) = 0.467 mW/g

Body 190ch/Zoom Scan (5x5x7)/Cube 0: Measurement grid: dx=8mm, dy=8mm, dz=5mm
 Reference Value = 12.5 V/m; Power Drift = 0.025 dB
 Peak SAR (extrapolated) = 0.571 W/kg
SAR(1 g) = 0.431 mW/g; SAR(10 g) = 0.303 mW/g

[Info: Interpolated medium parameters used for SAR evaluation.](#)
 Maximum value of SAR (measured) = 0.460 mW/g

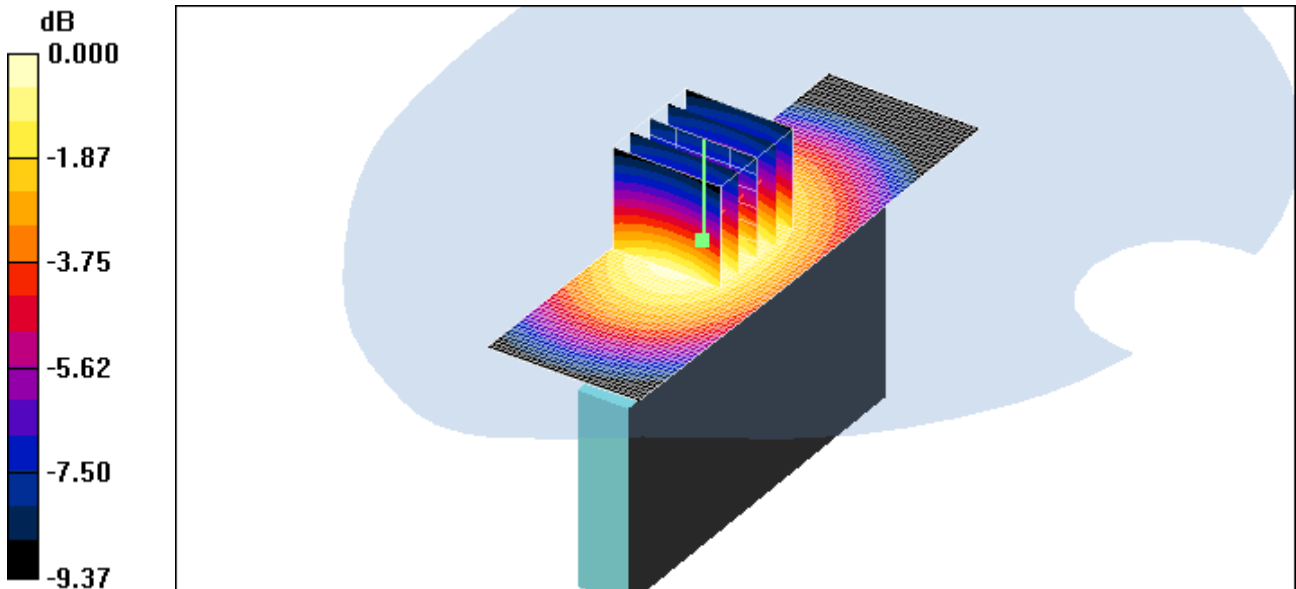

0 dB = 0.460mW/g

Test Laboratory: HCT CO., LTD
 EUT Type: GSM/WCDMA Phone with Bluetooth & WLAN
 GPRS Class10 and GPRS mode class B(GPRS and GSM, but not simultaneously)
 Liquid Temperature: 21.2 °C
 Ambient Temperature: 21.4 °C
 Test Date: Mar.20, 2011

DUT: P8000; Type: Bar top; Serial: #1

Communication System: GSM 850; Frequency: 836.6 MHz; Duty Cycle: 1:4.15
 Medium parameters used (interpolated): $f = 836.6 \text{ MHz}$; $\sigma = 0.982 \text{ mho/m}$; $\epsilon_r = 56.8$; $\rho = 1000 \text{ kg/m}^3$
 Phantom section: Flat Section ; Measurement SW: DASY4, V4.7 Build 80; Postprocessing SW: SEMCAD, V1.8 Build 184

DASY4 Configuration:
 - Probe: ET3DV6 - SN1630; ConvF(6.17, 6.17, 6.17); Calibrated: 2010-05-25
 - Sensor-Surface: 4mm (Mechanical Surface Detection)
 - Electronics: DAE4 Sn869; Calibrated: 2010-09-21
 - Phantom: 835/900 Phantom ; Type: SAM

Body 190/Area Scan (41x61x1): Measurement grid: dx=15mm, dy=15mm

[Info: Interpolated medium parameters used for SAR evaluation.](#)
 Maximum value of SAR (interpolated) = 0.663 mW/g

Body 190/Zoom Scan (5x5x7)/Cube 0: Measurement grid: dx=8mm, dy=8mm, dz=5mm
 Reference Value = 12.7 V/m; Power Drift = 0.189 dB
 Peak SAR (extrapolated) = 1.72 W/kg
SAR(1 g) = 0.620 mW/g; SAR(10 g) = 0.279 mW/g

[Info: Interpolated medium parameters used for SAR evaluation.](#)
 Maximum value of SAR (measured) = 0.691 mW/g

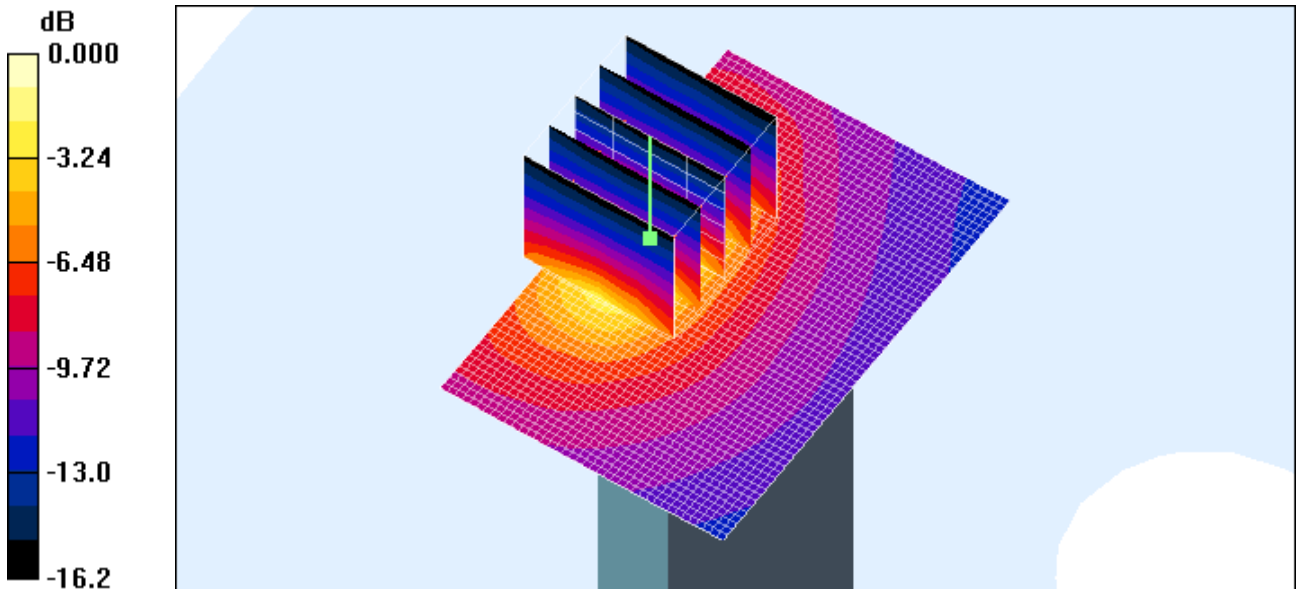

0 dB = 0.691mW/g

Test Laboratory: HCT CO., LTD
 EUT Type: GSM/WCDMA Phone with Bluetooth & WLAN
 GPRS Class10 and GPRS mode class B(GPRS and GSM, but not simultaneously)
 Liquid Temperature: 21.3 °C
 Ambient Temperature: 21.5 °C
 Test Date: Mar.21, 2011

DUT: P8000; Type: Bar; Serial: #1

Communication System: GSM 1900; Frequency: 1880 MHz; Duty Cycle: 1:4.15
 Medium parameters used: $f = 1880 \text{ MHz}$; $\sigma = 1.57 \text{ mho/m}$; $\epsilon_r = 53.5$; $\rho = 1000 \text{ kg/m}^3$
 Phantom section: Flat Section ; Measurement SW: DASY4, V4.7 Build 80; Postprocessing SW: SEMCAD, V1.8 Build 184

DASY4 Configuration:
 - Probe: ET3DV6 - SN1630; ConvF(4.55, 4.55, 4.55); Calibrated: 2010-05-25
 - Sensor-Surface: 4mm (Mechanical Surface Detection)
 - Electronics: DAE4 Sn869; Calibrated: 2010-09-21
 - Phantom: SAM 1800/1900 MHz; Type: SAM

GSM Body 661/Area Scan (61x91x1): Measurement grid: dx=15mm, dy=15mm
 Maximum value of SAR (interpolated) = 0.156 mW/g

GSM Body 661/Zoom Scan (5x5x7)/Cube 0: Measurement grid: dx=8mm, dy=8mm, dz=5mm
 Reference Value = 8.02 V/m; Power Drift = 0.193 dB
 Peak SAR (extrapolated) = 0.239 W/kg
SAR(1 g) = 0.151 mW/g; SAR(10 g) = 0.086 mW/g
 Maximum value of SAR (measured) = 0.166 mW/g

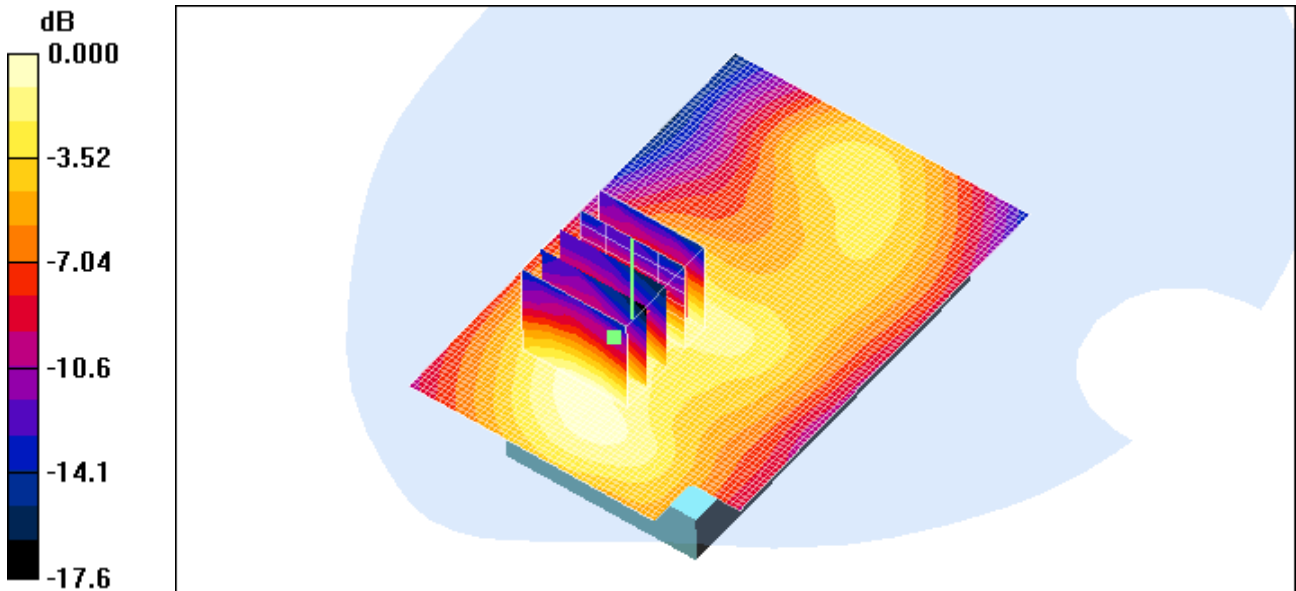

0 dB = 0.166mW/g

Test Laboratory: HCT CO., LTD
 EUT Type: GSM/WCDMA Phone with Bluetooth & WLAN
 GPRS Class10 and GPRS mode class B(GPRS and GSM, but not simultaneously)
 Liquid Temperature: 21.3 °C
 Ambient Temperature: 21.5 °C
 Test Date: Mar.21, 2011

DUT: P8000; Type: Bar; Serial: #1

Communication System: GSM 1900; Frequency: 1850.2 MHz; Duty Cycle: 1:4.15
 Medium parameters used (interpolated): $f = 1850.2 \text{ MHz}$; $\sigma = 1.54 \text{ mho/m}$; $\epsilon_r = 53.8$; $\rho = 1000 \text{ kg/m}^3$
 Phantom section: Flat Section ; Measurement SW: DASY4, V4.7 Build 80; Postprocessing SW: SEMCAD, V1.8 Build 184

DASY4 Configuration:
 - Probe: ET3DV6 - SN1630; ConvF(4.55, 4.55, 4.55); Calibrated: 2010-05-25
 - Sensor-Surface: 4mm (Mechanical Surface Detection)
 - Electronics: DAE4 Sn869; Calibrated: 2010-09-21
 - Phantom: SAM 1800/1900 MHz; Type: SAM

GSM Body 512/Area Scan (61x91x1): Measurement grid: dx=15mm, dy=15mm

[Info: Interpolated medium parameters used for SAR evaluation.](#)
 Maximum value of SAR (interpolated) = 0.811 mW/g

GSM Body 512/Zoom Scan (5x5x7)/Cube 0: Measurement grid: dx=8mm, dy=8mm, dz=5mm
 Reference Value = 9.96 V/m; Power Drift = -0.045 dB
 Peak SAR (extrapolated) = 0.989 W/kg
SAR(1 g) = 0.645 mW/g; SAR(10 g) = 0.347 mW/g
 Maximum value of SAR (measured) = 0.722 mW/g

GSM Body 512/Zoom Scan (5x5x7)/Cube 1: Measurement grid: dx=8mm, dy=8mm, dz=5mm
 Reference Value = 9.96 V/m; Power Drift = -0.045 dB
 Peak SAR (extrapolated) = 0.793 W/kg
SAR(1 g) = 0.514 mW/g; SAR(10 g) = 0.297 mW/g
 Maximum value of SAR (measured) = 0.569 mW/g

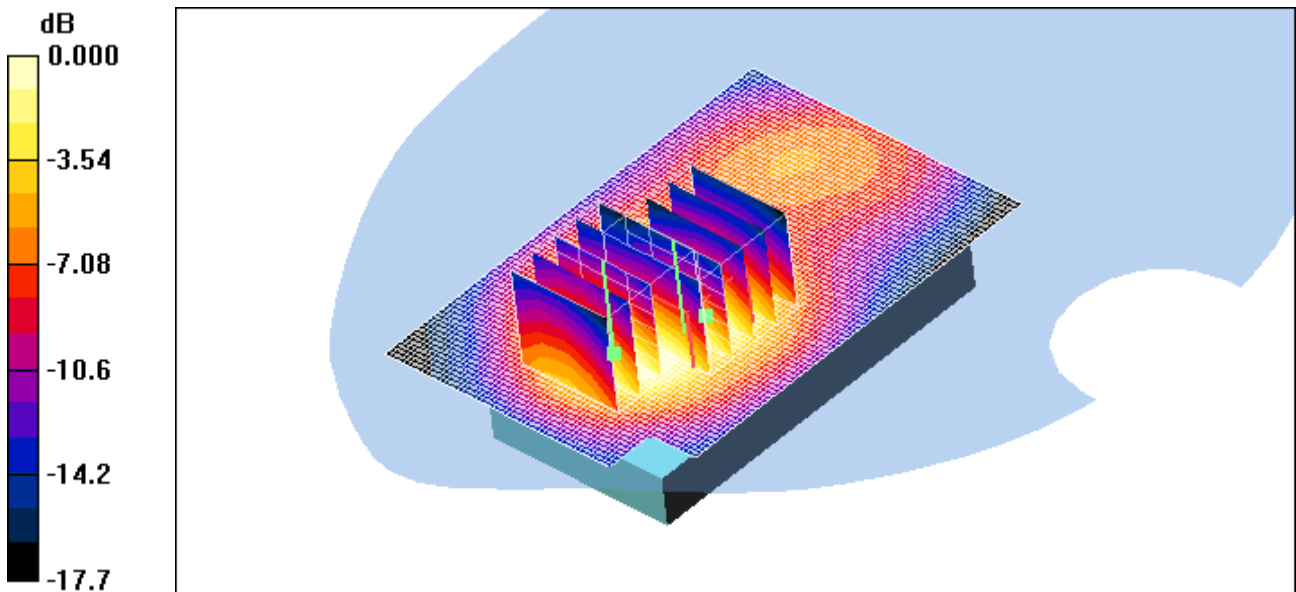

0 dB = 0.569mW/g

Test Laboratory: HCT CO., LTD
EUT Type: GSM/WCDMA Phone with Bluetooth & WLAN
GPRS Class10 and GPRS mode class B(GPRS and GSM, but not simultaneously)
Liquid Temperature: 21.3 °C
Ambient Temperature: 21.5 °C
Test Date: Mar.21, 2011

DUT: P8000; Type: Bar; Serial: #1

Communication System: GSM 1900; Frequency: 1880 MHz; Duty Cycle: 1:4.15
Medium parameters used: $f = 1880 \text{ MHz}$; $\sigma = 1.57 \text{ mho/m}$; $\epsilon_r = 53.5$; $\rho = 1000 \text{ kg/m}^3$
Phantom section: Flat Section ; Measurement SW: DASY4, V4.7 Build 80; Postprocessing SW: SEMCAD, V1.8 Build 184

DASY4 Configuration:

- Probe: ET3DV6 - SN1630; ConvF(4.55, 4.55, 4.55); Calibrated: 2010-05-25
- Sensor-Surface: 4mm (Mechanical Surface Detection)
- Electronics: DAE4 Sn869; Calibrated: 2010-09-21
- Phantom: SAM 1800/1900 MHz; Type: SAM

GSM Body 661/Area Scan (61x91x1): Measurement grid: dx=15mm, dy=15mm
Maximum value of SAR (interpolated) = 1.08 mW/g

GSM Body 661/Zoom Scan (5x5x7)/Cube 0: Measurement grid: dx=8mm, dy=8mm, dz=5mm
Reference Value = 10.1 V/m; Power Drift = -0.041 dB
Peak SAR (extrapolated) = 1.36 W/kg
SAR(1 g) = 0.878 mW/g; SAR(10 g) = 0.466 mW/g
Maximum value of SAR (measured) = 1.00 mW/g

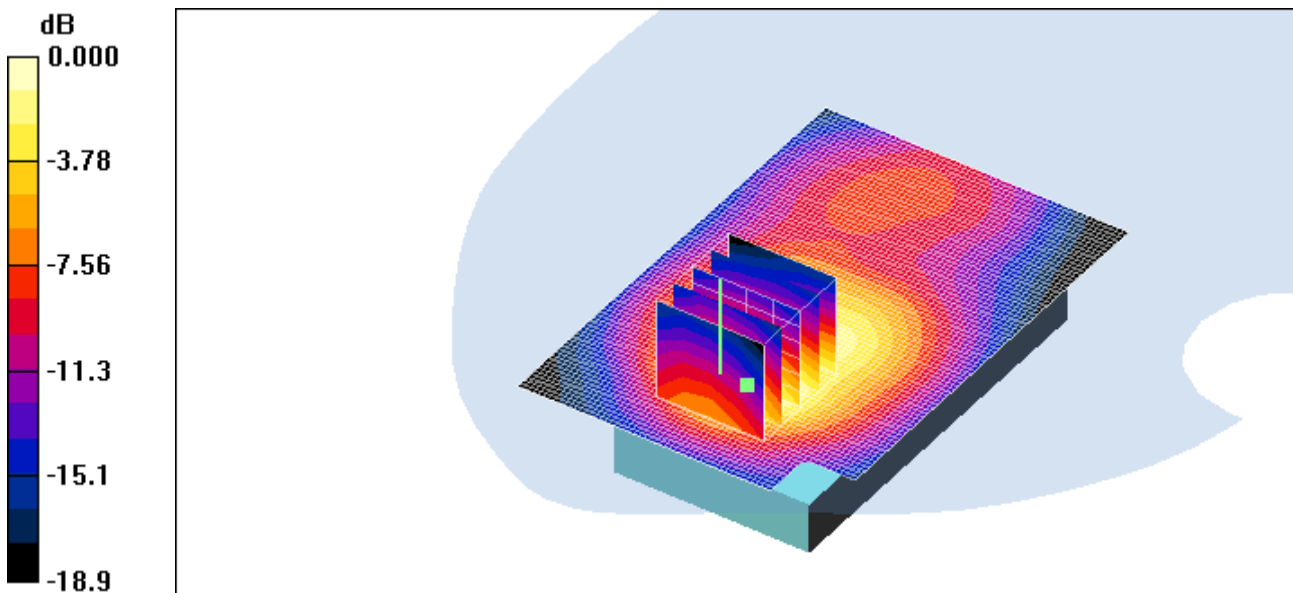

0 dB = 1.00mW/g

Test Laboratory: HCT CO., LTD
EUT Type: GSM/WCDMA Phone with Bluetooth & WLAN
GPRS Class10 and GPRS mode class B(GPRS and GSM, but not simultaneously)
Liquid Temperature: 21.3 °C
Ambient Temperature: 21.5 °C
Test Date: Mar.21, 2011

DUT: P8000; Type: Bar; Serial: #1

Communication System: GSM 1900; Frequency: 1909.8 MHz; Duty Cycle: 1:4.15
Medium parameters used: $f = 1910$ MHz; $\sigma = 1.59$ mho/m; $\epsilon_r = 53.2$; $\rho = 1000$ kg/m³
Phantom section: Flat Section ; Measurement SW: DASY4, V4.7 Build 80; Postprocessing SW: SEMCAD, V1.8 Build 184

DASY4 Configuration:

- Probe: ET3DV6 - SN1630; ConvF(4.55, 4.55, 4.55); Calibrated: 2010-05-25
- Sensor-Surface: 4mm (Mechanical Surface Detection)
- Electronics: DAE4 Sn869; Calibrated: 2010-09-21
- Phantom: SAM 1800/1900 MHz; Type: SAM

PCS Body 810/Area Scan (61x91x1): Measurement grid: dx=15mm, dy=15mm
Maximum value of SAR (interpolated) = 1.16 mW/g

PCS Body 810/Zoom Scan (5x5x7)/Cube 0: Measurement grid: dx=8mm, dy=8mm, dz=5mm
Reference Value = 10.7 V/m; Power Drift = -0.179 dB
Peak SAR (extrapolated) = 1.59 W/kg
SAR(1 g) = 0.996 mW/g; SAR(10 g) = 0.525 mW/g
Maximum value of SAR (measured) = 1.13 mW/g

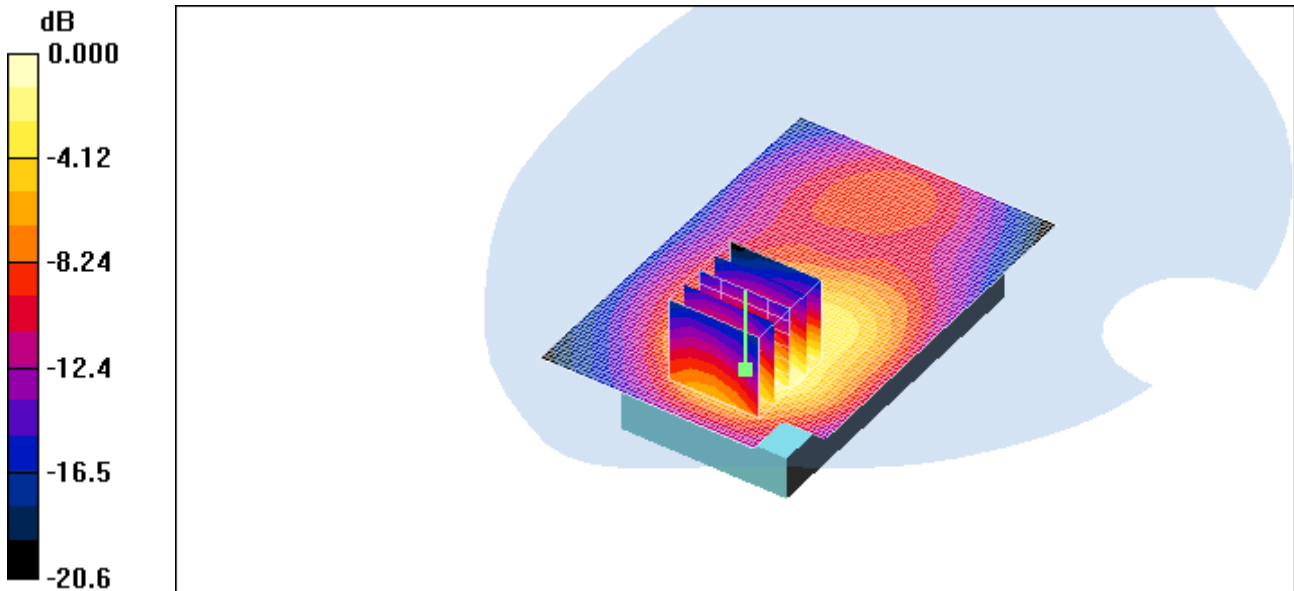

0 dB = 1.13mW/g

Test Laboratory: HCT CO., LTD
 EUT Type: GSM/WCDMA Phone with Bluetooth & WLAN
 GPRS Class10 and GPRS mode class B(GPRS and GSM, but not simultaneously)
 Liquid Temperature: 21.3 °C
 Ambient Temperature: 21.5 °C
 Test Date: Mar.21, 2011

DUT: P8000; Type: Bar side; Serial: #1

Communication System: GSM 1900; Frequency: 1880 MHz; Duty Cycle: 1:4,15
 Medium parameters used: $f = 1880 \text{ MHz}$; $\sigma = 1.57 \text{ mho/m}$; $\epsilon_r = 53.5$; $\rho = 1000 \text{ kg/m}^3$
 Phantom section: Flat Section ; Measurement SW: DASY4, V4.7 Build 80; Postprocessing SW: SEMCAD, V1.8 Build 184

DASY4 Configuration:
 - Probe: ET3DV6 - SN1630; ConvF(4.55, 4.55, 4.55); Calibrated: 2010-05-25
 - Sensor-Surface: 4mm (Mechanical Surface Detection)
 - Electronics: DAE4 Sn869; Calibrated: 2010-09-21
 - Phantom: SAM 1800/1900 MHz; Type: SAM

Body 661ch/Area Scan (31x101x1): Measurement grid: dx=15mm, dy=15mm
 Maximum value of SAR (interpolated) = 0.141 mW/g

Body 661ch/Zoom Scan (5x5x7)/Cube 0: Measurement grid: dx=8mm, dy=8mm, dz=5mm
 Reference Value = 5.64 V/m; Power Drift = -0.026 dB
 Peak SAR (extrapolated) = 0.180 W/kg
SAR(1 g) = 0.120 mW/g; SAR(10 g) = 0.076 mW/g
 Maximum value of SAR (measured) = 0.130 mW/g

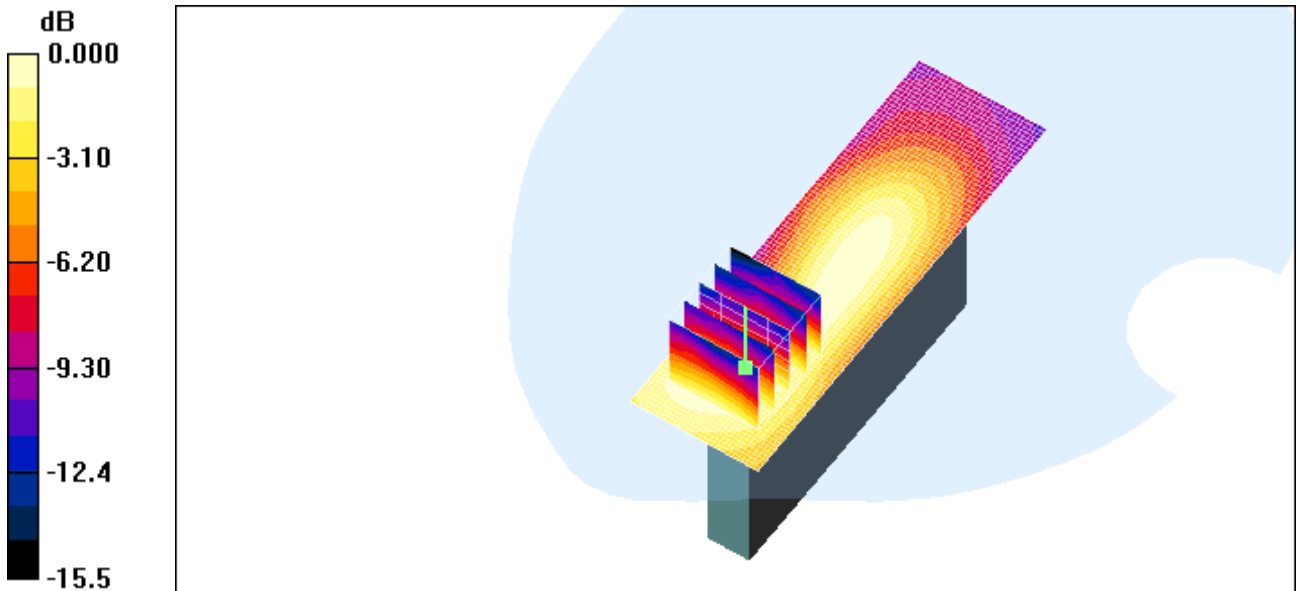

0 dB = 0.130mW/g

Test Laboratory: HCT CO., LTD
EUT Type: GSM/WCDMA Phone with Bluetooth & WLAN
GPRS Class10 and GPRS mode class B(GPRS and GSM, but not simultaneously)
Liquid Temperature: 21.3 °C
Ambient Temperature: 21.5 °C
Test Date: Mar.21, 2011

DUT: P8000; Type: Bar side; Serial: #1

Communication System: GSM 1900; Frequency: 1880 MHz; Duty Cycle: 1:4,15
Medium parameters used: $f = 1880 \text{ MHz}$; $\sigma = 1.57 \text{ mho/m}$; $\epsilon_r = 53.5$; $\rho = 1000 \text{ kg/m}^3$
Phantom section: Flat Section ; Measurement SW: DASY4, V4.7 Build 80; Postprocessing SW: SEMCAD, V1.8 Build 184

DASY4 Configuration:

- Probe: ET3DV6 - SN1630; ConvF(4.55, 4.55, 4.55); Calibrated: 2010-05-25
- Sensor-Surface: 4mm (Mechanical Surface Detection)
- Electronics: DAE4 Sn869; Calibrated: 2010-09-21
- Phantom: SAM 1800/1900 MHz; Type: SAM

Body 661ch/Area Scan (31x101x1): Measurement grid: dx=15mm, dy=15mm
Maximum value of SAR (interpolated) = 0.127 mW/g

Body 661ch/Zoom Scan (5x5x7)/Cube 0: Measurement grid: dx=8mm, dy=8mm, dz=5mm
Reference Value = 7.56 V/m; Power Drift = 0.192 dB
Peak SAR (extrapolated) = 0.163 W/kg
SAR(1 g) = 0.112 mW/g; SAR(10 g) = 0.068 mW/g
Maximum value of SAR (measured) = 0.122 mW/g

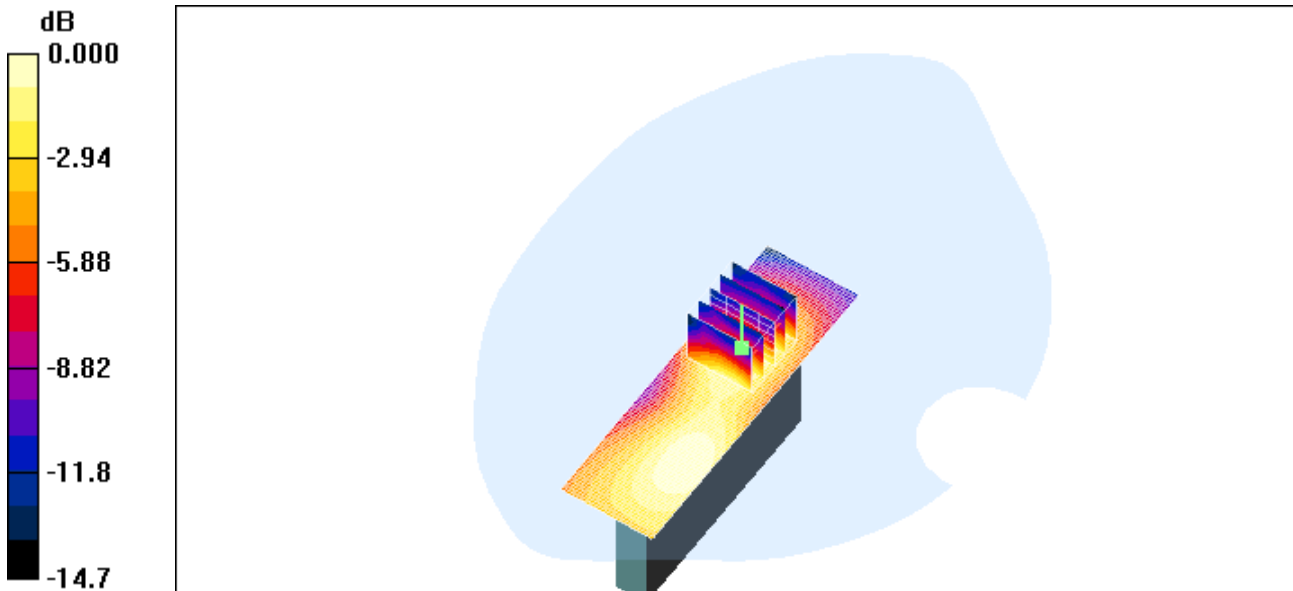

0 dB = 0.122mW/g

Test Laboratory: HCT CO., LTD
 EUT Type: GSM/WCDMA Phone with Bluetooth & WLAN
 GPRS Class10 and GPRS mode class B(GPRS and GSM, but not simultaneously)
 Liquid Temperature: 21.3 °C
 Ambient Temperature: 21.5 °C
 Test Date: Mar.21, 2011

DUT: P8000; Type: Bar top; Serial: #1

Communication System: GSM 1900; Frequency: 1850.2 MHz; Duty Cycle: 1:4.15
 Medium parameters used (interpolated): $f = 1850.2 \text{ MHz}$; $\sigma = 1.54 \text{ mho/m}$; $\epsilon_r = 53.8$; $\rho = 1000 \text{ kg/m}^3$
 Phantom section: Flat Section ; Measurement SW: DASY4, V4.7 Build 80; Postprocessing SW: SEMCAD, V1.8 Build 184

DASY4 Configuration:
 - Probe: ET3DV6 - SN1630; ConvF(4.55, 4.55, 4.55); Calibrated: 2010-05-25
 - Sensor-Surface: 4mm (Mechanical Surface Detection)
 - Electronics: DAE4 Sn869; Calibrated: 2010-09-21
 - Phantom: SAM 1800/1900 MHz; Type: SAM

Body 512/Area Scan (41x61x1): Measurement grid: dx=15mm, dy=15mm

[Info: Interpolated medium parameters used for SAR evaluation.](#)
 Maximum value of SAR (interpolated) = 0.836 mW/g

Body 512/Zoom Scan (5x5x7)/Cube 0: Measurement grid: dx=8mm, dy=8mm, dz=5mm
 Reference Value = 24.6 V/m; Power Drift = 0.033 dB
 Peak SAR (extrapolated) = 1.24 W/kg
SAR(1 g) = 0.748 mW/g; SAR(10 g) = 0.372 mW/g

[Info: Interpolated medium parameters used for SAR evaluation.](#)
 Maximum value of SAR (measured) = 0.870 mW/g

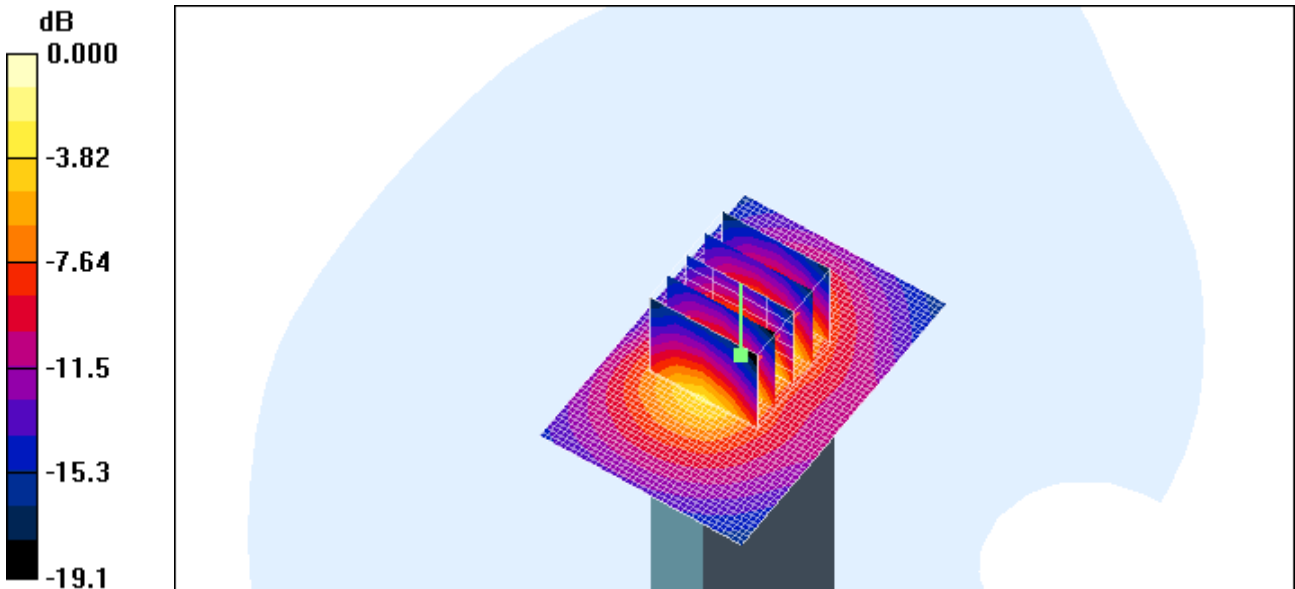

0 dB = 0.870mW/g

Test Laboratory: HCT CO., LTD
 EUT Type: GSM/WCDMA Phone with Bluetooth & WLAN
 GPRS Class10 and GPRS mode class B(GPRS and GSM, but not simultaneously)
 Liquid Temperature: 21.3 °C
 Ambient Temperature: 21.5 °C
 Test Date: Mar.21, 2011

DUT: P8000; Type: Bar top; Serial: #1

Communication System: GSM 1900; Frequency: 1880 MHz; Duty Cycle: 1:4,15
 Medium parameters used: $f = 1880 \text{ MHz}$; $\sigma = 1.57 \text{ mho/m}$; $\epsilon_r = 53.5$; $\rho = 1000 \text{ kg/m}^3$
 Phantom section: Flat Section ; Measurement SW: DASY4, V4.7 Build 80; Postprocessing SW: SEMCAD, V1.8 Build 184

DASY4 Configuration:
 - Probe: ET3DV6 - SN1630; ConvF(4.55, 4.55, 4.55); Calibrated: 2010-05-25
 - Sensor-Surface: 4mm (Mechanical Surface Detection)
 - Electronics: DAE4 Sn869; Calibrated: 2010-09-21
 - Phantom: SAM 1800/1900 MHz; Type: SAM

Body 661/Area Scan (41x61x1): Measurement grid: dx=15mm, dy=15mm
 Maximum value of SAR (interpolated) = 0.996 mW/g

Body 661/Zoom Scan (5x5x7)/Cube 0: Measurement grid: dx=8mm, dy=8mm, dz=5mm
 Reference Value = 26.8 V/m; Power Drift = 0.103 dB
 Peak SAR (extrapolated) = 1.47 W/kg
SAR(1 g) = 0.894 mW/g; SAR(10 g) = 0.450 mW/g
 Maximum value of SAR (measured) = 1.04 mW/g

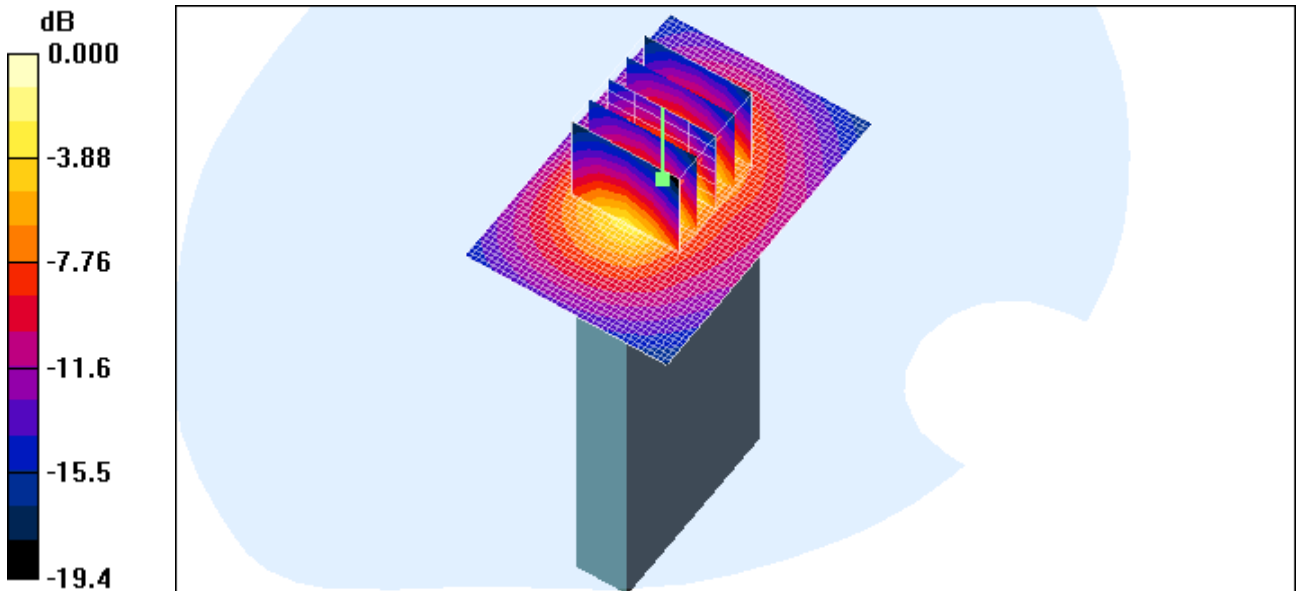

0 dB = 1.04mW/g

Test Laboratory: HCT CO., LTD
EUT Type: GSM/WCDMA Phone with Bluetooth & WLAN
GPRS Class10 and GPRS mode class B(GPRS and GSM, but not simultaneously)
Liquid Temperature: 21.3 °C
Ambient Temperature: 21.5 °C
Test Date: Mar.21, 2011

DUT: P8000; Type: Bar top; Serial: #1

Communication System: GSM 1900; Frequency: 1909.8 MHz; Duty Cycle: 1:4.15
Medium parameters used: $f = 1910$ MHz; $\sigma = 1.59$ mho/m; $\epsilon_r = 53.2$; $\rho = 1000$ kg/m³
Phantom section: Flat Section ; Measurement SW: DASY4, V4.7 Build 80; Postprocessing SW: SEMCAD, V1.8 Build 184

DASY4 Configuration:

- Probe: ET3DV6 - SN1630; ConvF(4.55, 4.55, 4.55); Calibrated: 2010-05-25
- Sensor-Surface: 4mm (Mechanical Surface Detection)
- Electronics: DAE4 Sn869; Calibrated: 2010-09-21
- Phantom: SAM 1800/1900 MHz; Type: SAM

Body 810/Area Scan (41x61x1): Measurement grid: dx=15mm, dy=15mm
Maximum value of SAR (interpolated) = 1.07 mW/g

Body 810/Zoom Scan (5x5x7)/Cube 0: Measurement grid: dx=8mm, dy=8mm, dz=5mm
Reference Value = 27.8 V/m; Power Drift = 0.010 dB
Peak SAR (extrapolated) = 1.49 W/kg
SAR(1 g) = 0.941 mW/g; SAR(10 g) = 0.498 mW/g
Maximum value of SAR (measured) = 1.07 mW/g

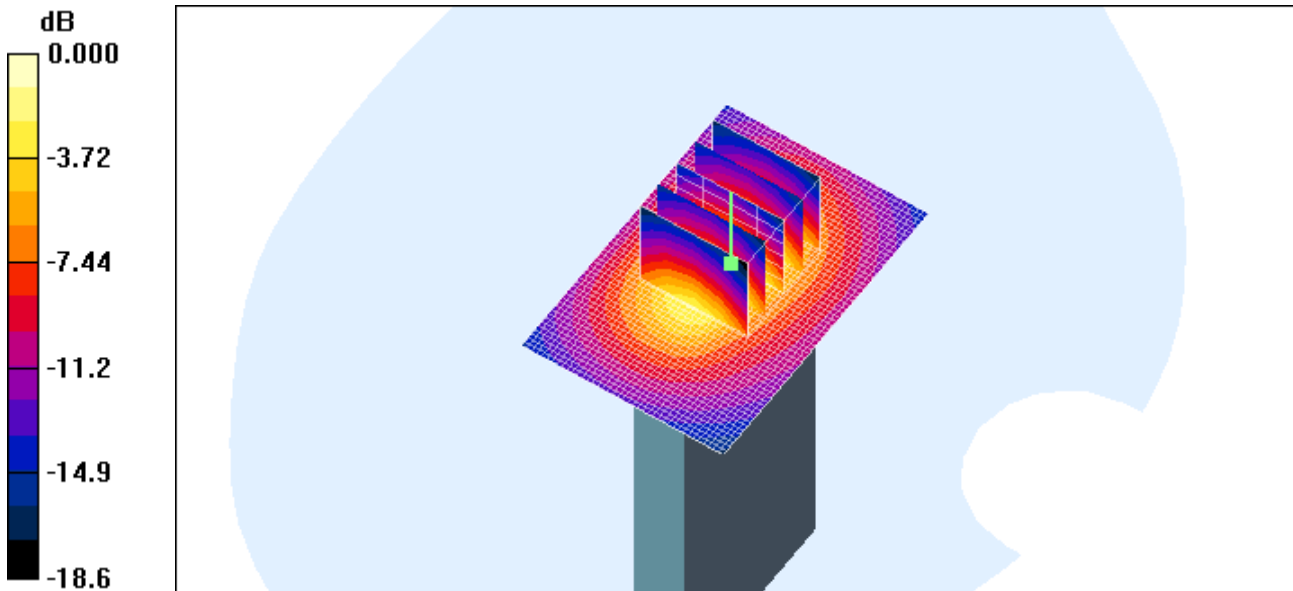

0 dB = 1.07mW/g

Test Laboratory: HCT CO., LTD
 EUT Type: GSM/WCDMA Phone with Bluetooth & WLAN
 GPRS Class10 and GPRS mode class B(GPRS and GSM, but not simultaneously)
 Liquid Temperature: 21.2 °C
 Ambient Temperature: 21.4 °C
 Test Date: Mar.20, 2011

DUT: P8000; Type: Bar; Serial: #1

Communication System: WCDMA850; Frequency: 836.6 MHz; Duty Cycle: 1:1
 Medium parameters used (interpolated): $f = 836.6 \text{ MHz}$; $\sigma = 0.982 \text{ mho/m}$; $\epsilon_r = 56.8$; $\rho = 1000 \text{ kg/m}^3$
 Phantom section: Flat Section ; Measurement SW: DASY4, V4.7 Build 80; Postprocessing SW: SEMCAD, V1.8 Build 184

DASY4 Configuration:
 - Probe: ET3DV6 - SN1630; ConvF(6.17, 6.17, 6.17); Calibrated: 2010-05-25
 - Sensor-Surface: 4mm (Mechanical Surface Detection)
 - Electronics: DAE4 Sn869; Calibrated: 2010-09-21
 - Phantom: 835/900 Phantom ; Type: SAM

Body 4183/Area Scan (61x91x1): Measurement grid: dx=15mm, dy=15mm

[Info: Interpolated medium parameters used for SAR evaluation.](#)
 Maximum value of SAR (interpolated) = 0.329 mW/g

Body 4183/Zoom Scan (5x5x7)/Cube 0: Measurement grid: dx=8mm, dy=8mm, dz=5mm
 Reference Value = 11.5 V/m; Power Drift = -0.15 dB
 Peak SAR (extrapolated) = 0.421 W/kg
SAR(1 g) = 0.333 mW/g; SAR(10 g) = 0.245 mW/g
 Maximum value of SAR (measured) = 0.352 mW/g

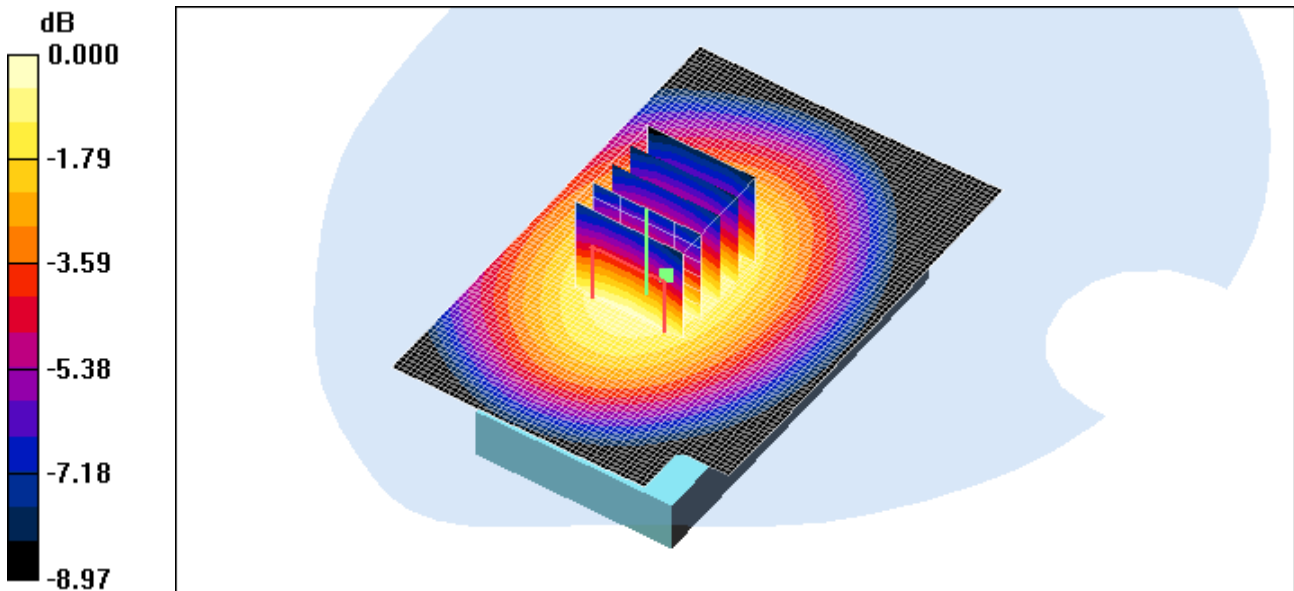

0 dB = 0.352mW/g

Test Laboratory: HCT CO., LTD
EUT Type: GSM/WCDMA Phone with Bluetooth & WLAN
GPRS Class10 and GPRS mode class B(GPRS and GSM, but not simultaneously)
Liquid Temperature: 21.2 °C
Ambient Temperature: 21.4 °C
Test Date: Mar.20, 2011

DUT: P8000; Type: Bar; Serial: #1

Communication System: WCDMA850; Frequency: 836.6 MHz; Duty Cycle: 1:1
Medium parameters used (interpolated): $f = 836.6$ MHz; $\sigma = 0.982$ mho/m; $\epsilon_r = 56.8$; $\rho = 1000$ kg/m³
Phantom section: Flat Section ; Measurement SW: DASY4, V4.7 Build 80; Postprocessing SW: SEMCAD, V1.8 Build 184

DASY4 Configuration:

- Probe: ET3DV6 - SN1630; ConvF(6.17, 6.17, 6.17); Calibrated: 2010-05-25
- Sensor-Surface: 4mm (Mechanical Surface Detection)
- Electronics: DAE4 Sn869; Calibrated: 2010-09-21
- Phantom: 835/900 Phantom ; Type: SAM

Body 4183/Area Scan (61x91x1): Measurement grid: dx=15mm, dy=15mm

[Info: Interpolated medium parameters used for SAR evaluation.](#)

Maximum value of SAR (interpolated) = 0.663 mW/g

Body 4183/Zoom Scan (5x5x7)/Cube 0: Measurement grid: dx=8mm, dy=8mm, dz=5mm

Reference Value = 15.9 V/m; Power Drift = -0.089 dB

Peak SAR (extrapolated) = 0.777 W/kg

SAR(1 g) = 0.617 mW/g; SAR(10 g) = 0.452 mW/g

[Info: Interpolated medium parameters used for SAR evaluation.](#)

Maximum value of SAR (measured) = 0.652 mW/g

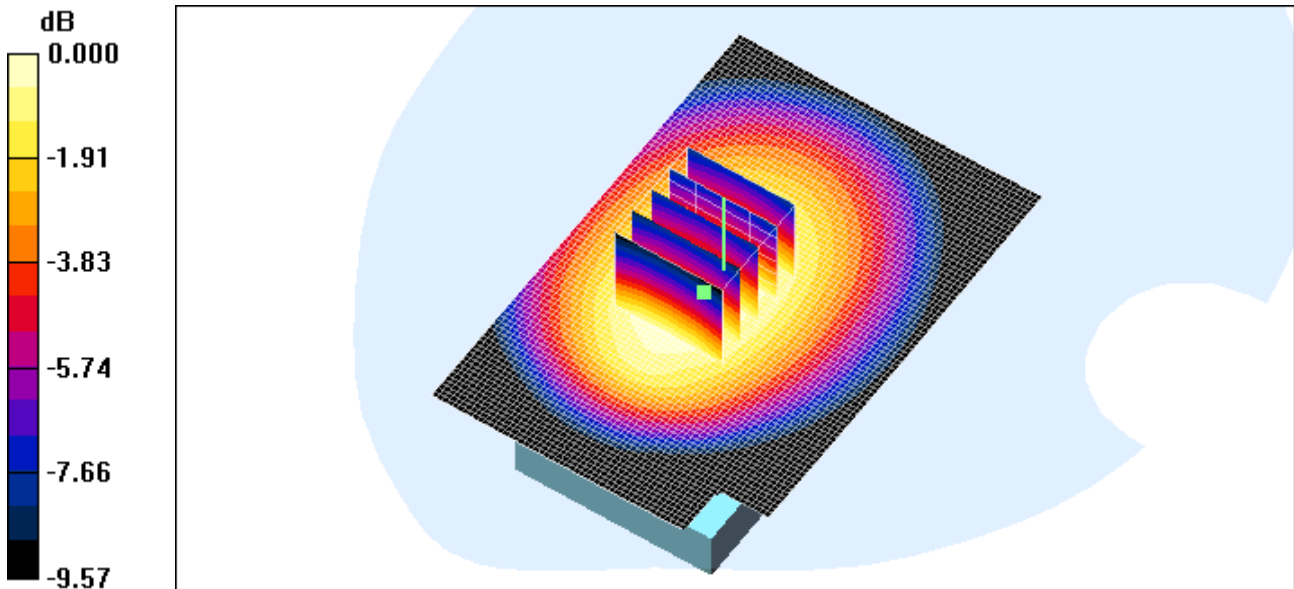

0 dB = 0.652mW/g

Test Laboratory: HCT CO., LTD
 EUT Type: GSM/WCDMA Phone with Bluetooth & WLAN
 GPRS Class10 and GPRS mode class B(GPRS and GSM, but not simultaneously)
 Liquid Temperature: 21.2 °C
 Ambient Temperature: 21.4 °C
 Test Date: Mar.20, 2011

DUT: P8000; Type: Bar side; Serial: #1

Communication System: WCDMA850; Frequency: 836.6 MHz; Duty Cycle: 1:1
 Medium parameters used (interpolated): $f = 836.6 \text{ MHz}$; $\sigma = 0.982 \text{ mho/m}$; $\epsilon_r = 56.8$; $\rho = 1000 \text{ kg/m}^3$
 Phantom section: Flat Section ; Measurement SW: DASY4, V4.7 Build 80; Postprocessing SW: SEMCAD, V1.8 Build 184

DASY4 Configuration:
 - Probe: ET3DV6 - SN1630; ConvF(6.17, 6.17, 6.17); Calibrated: 2010-05-25
 - Sensor-Surface: 4mm (Mechanical Surface Detection)
 - Electronics: DAE4 Sn869; Calibrated: 2010-09-21
 - Phantom: 835/900 Phantom ; Type: SAM

Body 4183/Area Scan (31x101x1): Measurement grid: dx=15mm, dy=15mm

[Info: Interpolated medium parameters used for SAR evaluation.](#)
 Maximum value of SAR (interpolated) = 0.462 mW/g

Body 4183/Zoom Scan (5x5x7)/Cube 0: Measurement grid: dx=8mm, dy=8mm, dz=5mm
 Reference Value = 11.9 V/m; Power Drift = 0.038 dB
 Peak SAR (extrapolated) = 0.574 W/kg
SAR(1 g) = 0.426 mW/g; SAR(10 g) = 0.297 mW/g

[Info: Interpolated medium parameters used for SAR evaluation.](#)
 Maximum value of SAR (measured) = 0.453 mW/g

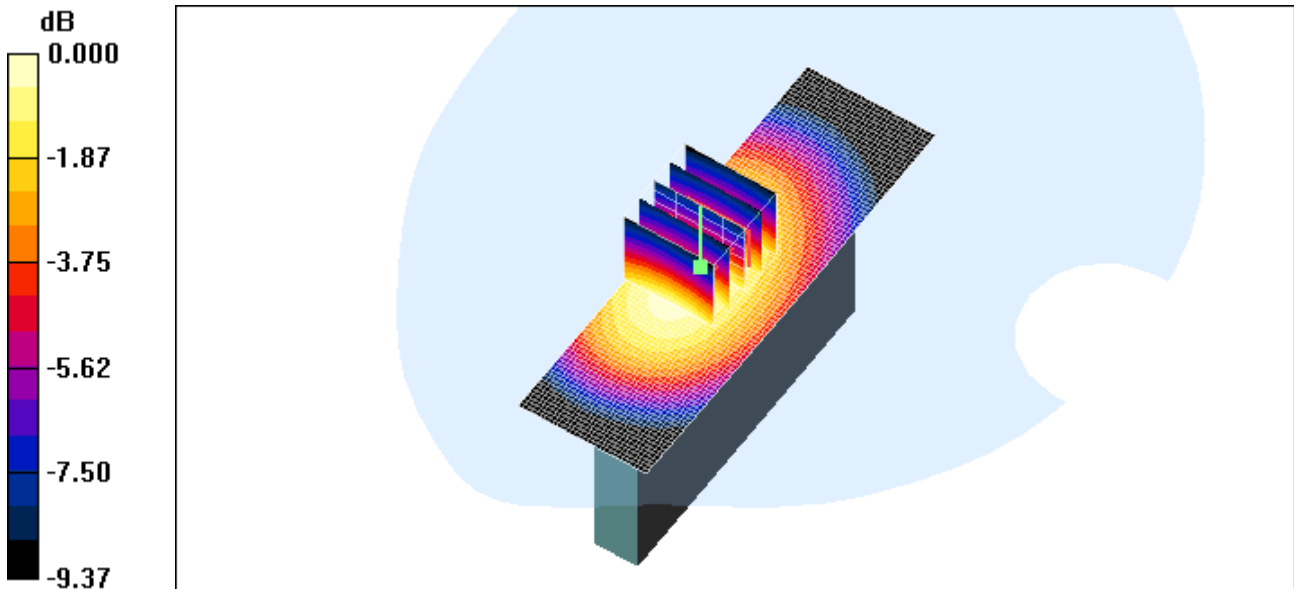

0 dB = 0.453mW/g

Test Laboratory: HCT CO., LTD
EUT Type: GSM/WCDMA Phone with Bluetooth & WLAN
GPRS Class10 and GPRS mode class B(GPRS and GSM, but not simultaneously)
Liquid Temperature: 21.2 °C
Ambient Temperature: 21.4 °C
Test Date: Mar.20, 2011

DUT: P8000; Type: Bar side; Serial: #1

Communication System: WCDMA850; Frequency: 836.6 MHz; Duty Cycle: 1:1
Medium parameters used (interpolated): $f = 836.6$ MHz; $\sigma = 0.982$ mho/m; $\epsilon_r = 56.8$; $\rho = 1000$ kg/m³
Phantom section: Flat Section ; Measurement SW: DASY4, V4.7 Build 80; Postprocessing SW: SEMCAD, V1.8 Build 184

DASY4 Configuration:

- Probe: ET3DV6 - SN1630; ConvF(6.17, 6.17, 6.17); Calibrated: 2010-05-25
- Sensor-Surface: 4mm (Mechanical Surface Detection)
- Electronics: DAE4 Sn869; Calibrated: 2010-09-21
- Phantom: 835/900 Phantom ; Type: SAM

Body 4183/Area Scan (31x101x1): Measurement grid: dx=15mm, dy=15mm

[Info: Interpolated medium parameters used for SAR evaluation.](#)

Maximum value of SAR (interpolated) = 0.345 mW/g

Body 4183/Zoom Scan (5x5x7)/Cube 0: Measurement grid: dx=8mm, dy=8mm, dz=5mm

Reference Value = 11.1 V/m; Power Drift = 0.115 dB

Peak SAR (extrapolated) = 0.426 W/kg

SAR(1 g) = 0.318 mW/g; SAR(10 g) = 0.223 mW/g

[Info: Interpolated medium parameters used for SAR evaluation.](#)

Maximum value of SAR (measured) = 0.338 mW/g

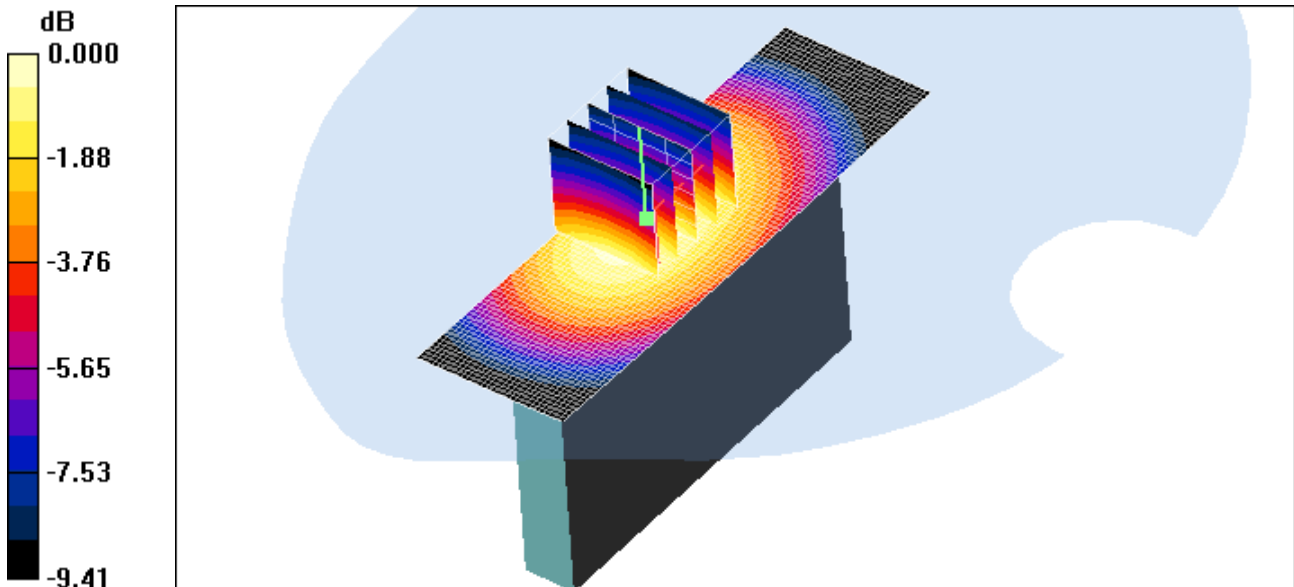

0 dB = 0.338mW/g

Test Laboratory: HCT CO., LTD
EUT Type: GSM/WCDMA Phone with Bluetooth & WLAN
GPRS Class10 and GPRS mode class B(GPRS and GSM, but not simultaneously)
Liquid Temperature: 21.2 °C
Ambient Temperature: 21.4 °C
Test Date: Mar.20, 2011

DUT: P8000; Type: Bar top; Serial: #1

Communication System: WCDMA850; Frequency: 836.6 MHz; Duty Cycle: 1:1
Medium parameters used (interpolated): $f = 836.6$ MHz; $\sigma = 0.982$ mho/m; $\epsilon_r = 56.8$; $\rho = 1000$ kg/m³
Phantom section: Flat Section ; Measurement SW: DASY4, V4.7 Build 80; Postprocessing SW: SEMCAD, V1.8 Build 184

DASY4 Configuration:

- Probe: ET3DV6 - SN1630; ConvF(6.17, 6.17, 6.17); Calibrated: 2010-05-25
- Sensor-Surface: 4mm (Mechanical Surface Detection)
- Electronics: DAE4 Sn869; Calibrated: 2010-09-21
- Phantom: 835/900 Phantom ; Type: SAM

Body 4183/Area Scan (41x61x1): Measurement grid: dx=15mm, dy=15mm

[Info: Interpolated medium parameters used for SAR evaluation.](#)

Maximum value of SAR (interpolated) = 0.273 mW/g

Body 4183/Zoom Scan (5x5x7)/Cube 0: Measurement grid: dx=8mm, dy=8mm, dz=5mm

Reference Value = 9.31 V/m; Power Drift = 0.140 dB

Peak SAR (extrapolated) = 0.659 W/kg

SAR(1 g) = 0.251 mW/g; SAR(10 g) = 0.117 mW/g

[Info: Interpolated medium parameters used for SAR evaluation.](#)

Maximum value of SAR (measured) = 0.280 mW/g

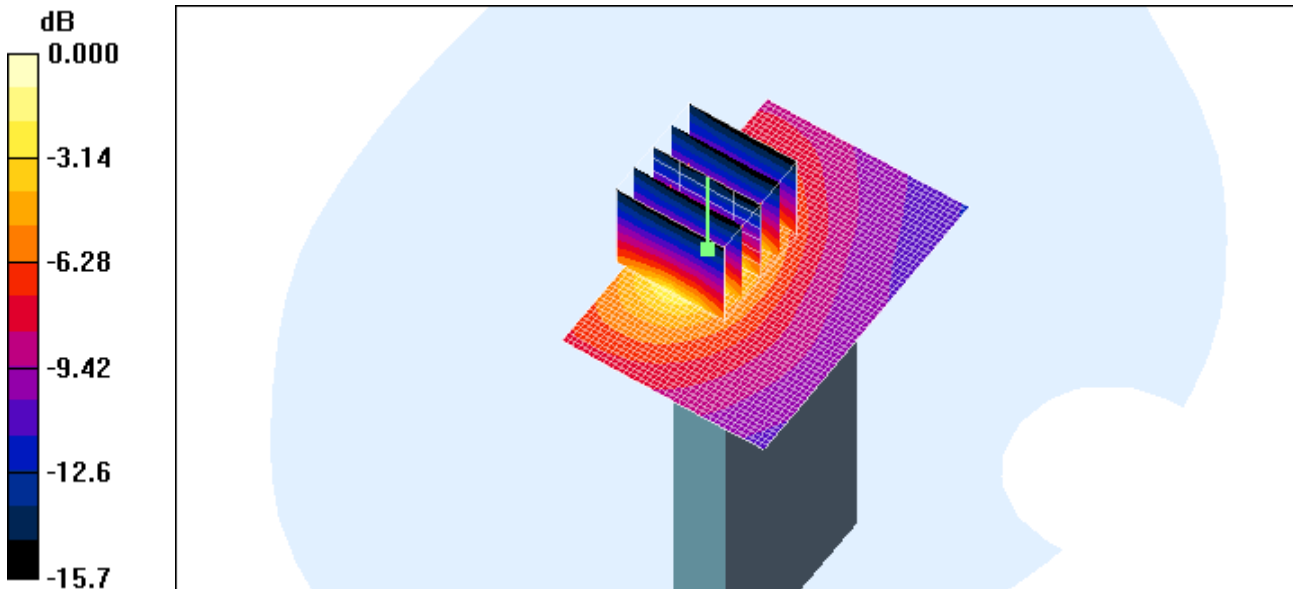

0 dB = 0.280mW/g

Test Laboratory: HCT CO., LTD
EUT Type: GSM/WCDMA Phone with Bluetooth & WLAN
GPRS Class10 and GPRS mode class B(GPRS and GSM, but not simultaneously)
Liquid Temperature: 21.3 °C
Ambient Temperature: 21.5 °C
Test Date: Mar.21, 2011

DUT: P8000; Type: Bar; Serial: #1

Communication System: WCDMA1900(FCC); Frequency: 1880 MHz;Duty Cycle: 1:1
Medium parameters used: $f = 1880 \text{ MHz}$; $\sigma = 1.57 \text{ mho/m}$; $\epsilon_r = 53.5$; $\rho = 1000 \text{ kg/m}^3$
Phantom section: Flat Section ; Measurement SW: DASY4, V4.7 Build 80; Postprocessing SW: SEMCAD, V1.8 Build 184

DASY4 Configuration:

- Probe: ET3DV6 - SN1630; ConvF(4.55, 4.55, 4.55); Calibrated: 2010-05-25
- Sensor-Surface: 4mm (Mechanical Surface Detection)
- Electronics: DAE4 Sn869; Calibrated: 2010-09-21
- Phantom: SAM 1800/1900 MHz; Type: SAM

WCDMA Body 9400/Area Scan (61x91x1): Measurement grid: $dx=15\text{mm}$, $dy=15\text{mm}$
Maximum value of SAR (interpolated) = 0.270 mW/g

WCDMA Body 9400/Zoom Scan (5x5x7)/Cube 0: Measurement grid: $dx=8\text{mm}$, $dy=8\text{mm}$, $dz=5\text{mm}$
Reference Value = 9.39 V/m; Power Drift = 0.142 dB
Peak SAR (extrapolated) = 0.452 W/kg
SAR(1 g) = 0.291 mW/g; SAR(10 g) = 0.162 mW/g
Maximum value of SAR (measured) = 0.323 mW/g

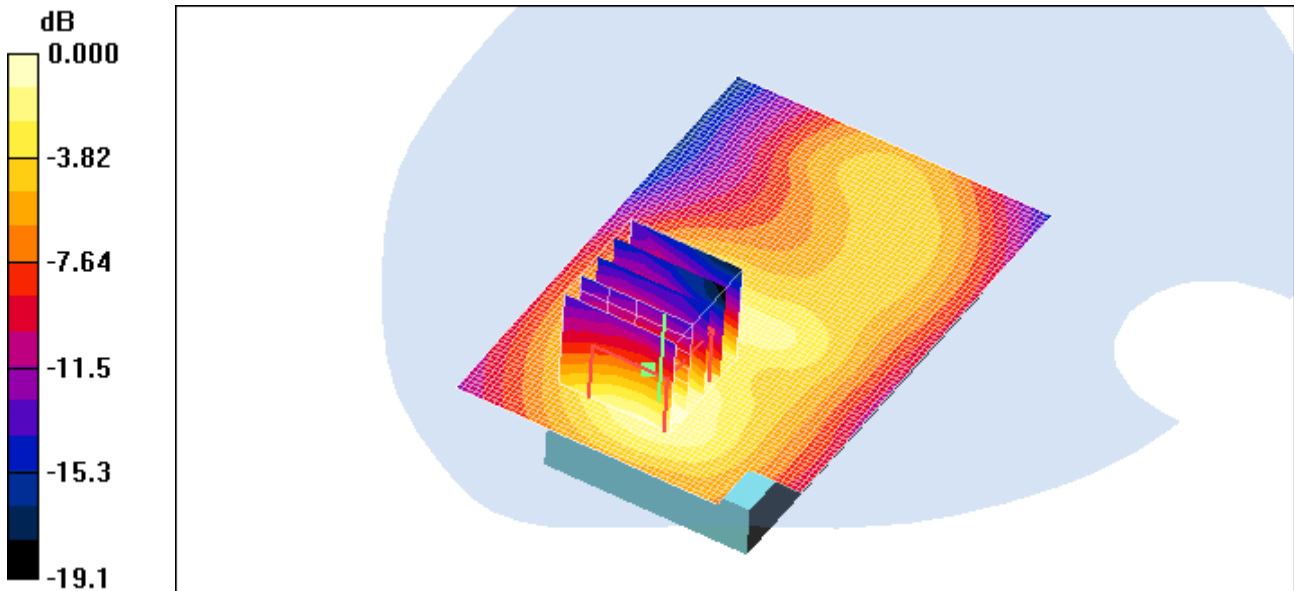

0 dB = 0.323mW/g

Test Laboratory: HCT CO., LTD
 EUT Type: GSM/WCDMA Phone with Bluetooth & WLAN
 GPRS Class10 and GPRS mode class B(GPRS and GSM, but not simultaneously)
 Liquid Temperature: 21.3 °C
 Ambient Temperature: 21.5 °C
 Test Date: Mar.21, 2011

DUT: P8000; Type: Bar; Serial: #1

Communication System: WCDMA1900(FCC); Frequency: 1852.4 MHz;Duty Cycle: 1:1
 Medium parameters used (interpolated): $f = 1852.4 \text{ MHz}$; $\sigma = 1.54 \text{ mho/m}$; $\epsilon_r = 53.7$; $\rho = 1000 \text{ kg/m}^3$
 Phantom section: Flat Section ; Measurement SW: DASY4, V4.7 Build 80; Postprocessing SW: SEMCAD, V1.8 Build 184

DASY4 Configuration:
 - Probe: ET3DV6 - SN1630; ConvF(4.55, 4.55, 4.55); Calibrated: 2010-05-25
 - Sensor-Surface: 4mm (Mechanical Surface Detection)
 - Electronics: DAE4 Sn869; Calibrated: 2010-09-21
 - Phantom: SAM 1800/1900 MHz; Type: SAM

PCS Body 9262/Area Scan (61x91x1): Measurement grid: dx=15mm, dy=15mm

[Info: Interpolated medium parameters used for SAR evaluation.](#)
 Maximum value of SAR (interpolated) = 1.14 mW/g

PCS Body 9262/Zoom Scan (5x5x7)/Cube 0: Measurement grid: dx=8mm, dy=8mm, dz=5mm
 Reference Value = 12.6 V/m; Power Drift = 0.037 dB
 Peak SAR (extrapolated) = 1.51 W/kg
SAR(1 g) = 0.967 mW/g; SAR(10 g) = 0.528 mW/g

[Info: Interpolated medium parameters used for SAR evaluation.](#)
 Maximum value of SAR (measured) = 1.12 mW/g

PCS Body 9262/Zoom Scan (5x5x7)/Cube 1: Measurement grid: dx=8mm, dy=8mm, dz=5mm
 Reference Value = 12.6 V/m; Power Drift = 0.037 dB
 Peak SAR (extrapolated) = 1.21 W/kg
SAR(1 g) = 0.793 mW/g; SAR(10 g) = 0.458 mW/g
 Maximum value of SAR (measured) = 0.878 mW/g

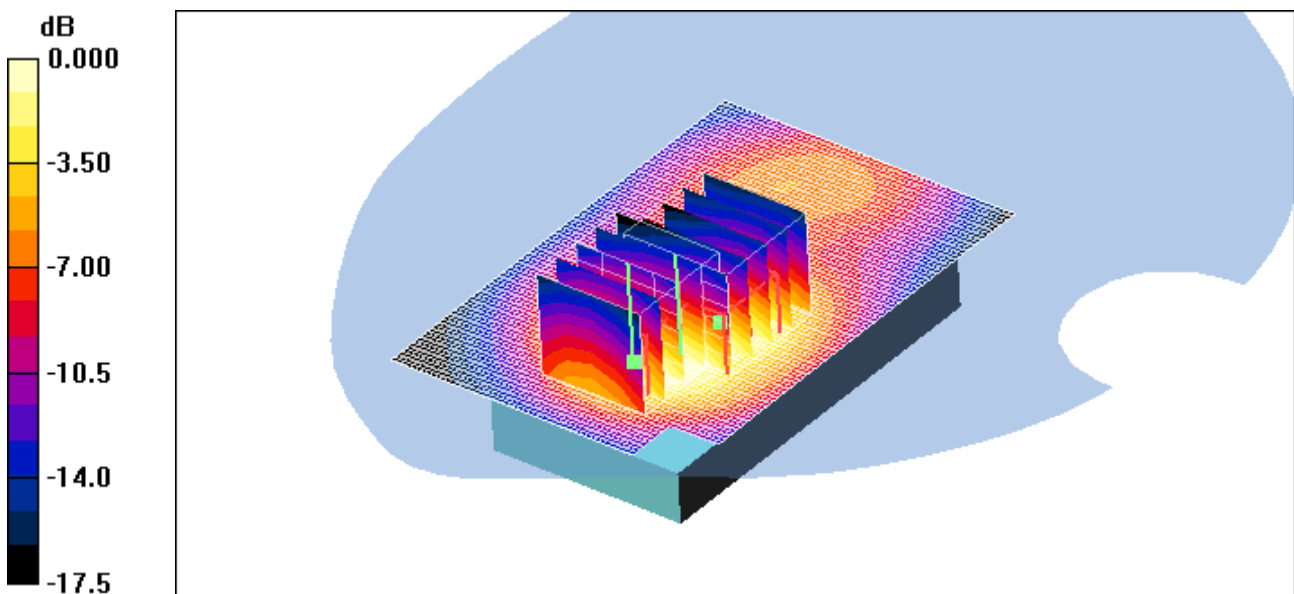

0 dB = 0.878mW/g

Test Laboratory: HCT CO., LTD
 EUT Type: GSM/WCDMA Phone with Bluetooth & WLAN
 GPRS Class10 and GPRS mode class B(GPRS and GSM, but not simultaneously)
 Liquid Temperature: 21.3 °C
 Ambient Temperature: 21.5 °C
 Test Date: Mar.21, 2011

DUT: P8000; Type: Bar; Serial: #1

Communication System: WCDMA1900(FCC); Frequency: 1880 MHz;Duty Cycle: 1:1
 Medium parameters used: $f = 1880 \text{ MHz}$; $\sigma = 1.57 \text{ mho/m}$; $\epsilon_r = 53.5$; $\rho = 1000 \text{ kg/m}^3$
 Phantom section: Flat Section ; Measurement SW: DASY4, V4.7 Build 80; Postprocessing SW: SEMCAD, V1.8 Build 184

DASY4 Configuration:
 - Probe: ET3DV6 - SN1630; ConvF(4.55, 4.55, 4.55); Calibrated: 2010-05-25
 - Sensor-Surface: 4mm (Mechanical Surface Detection)
 - Electronics: DAE4 Sn869; Calibrated: 2010-09-21
 - Phantom: SAM 1800/1900 MHz; Type: SAM

WCDMA Body 9400/Area Scan (61x91x1): Measurement grid: dx=15mm, dy=15mm
 Maximum value of SAR (interpolated) = 1.32 mW/g

WCDMA Body 9400/Zoom Scan (5x5x7)/Cube 0: Measurement grid: dx=8mm, dy=8mm, dz=5mm
 Reference Value = 12.0 V/m; Power Drift = 0.058 dB
 Peak SAR (extrapolated) = 1.84 W/kg
SAR(1 g) = 1.16 mW/g; SAR(10 g) = 0.615 mW/g
 Maximum value of SAR (measured) = 1.34 mW/g

WCDMA Body 9400/Zoom Scan (5x5x7)/Cube 1: Measurement grid: dx=8mm, dy=8mm, dz=5mm
 Reference Value = 12.0 V/m; Power Drift = 0.058 dB
 Peak SAR (extrapolated) = 1.34 W/kg
SAR(1 g) = 0.805 mW/g; SAR(10 g) = 0.459 mW/g
 Maximum value of SAR (measured) = 0.974 mW/g

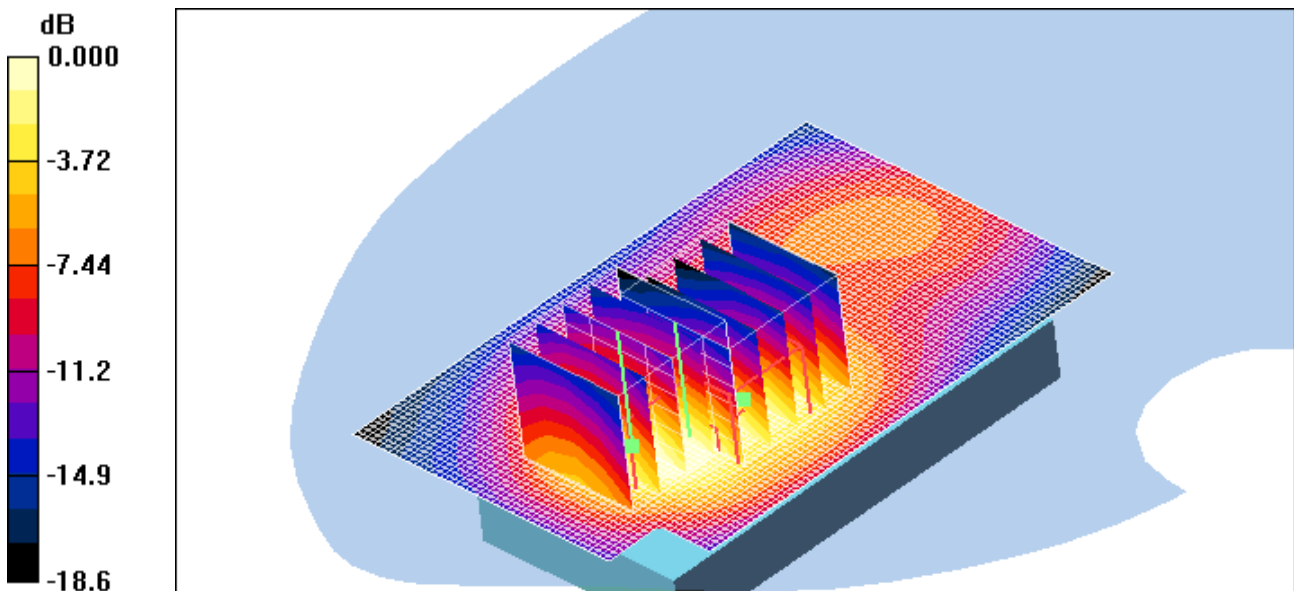

0 dB = 0.974mW/g

Test Laboratory: HCT CO., LTD
 EUT Type: GSM/WCDMA Phone with Bluetooth & WLAN
 GPRS Class10 and GPRS mode class B(GPRS and GSM, but not simultaneously)
 Liquid Temperature: 21.3 °C
 Ambient Temperature: 21.5 °C
 Test Date: Mar.21, 2011

DUT: P8000; Type: Bar; Serial: #1

Communication System: WCDMA1900(FCC); Frequency: 1907.6 MHz;Duty Cycle: 1:1
 Medium parameters used (interpolated): $f = 1907.6 \text{ MHz}$; $\sigma = 1.59 \text{ mho/m}$; $\epsilon_r = 53.2$; $\rho = 1000 \text{ kg/m}^3$
 Phantom section: Flat Section ; Measurement SW: DASY4, V4.7 Build 80; Postprocessing SW: SEMCAD, V1.8 Build 184

DASY4 Configuration:
 - Probe: ET3DV6 - SN1630; ConvF(4.55, 4.55, 4.55); Calibrated: 2010-05-25
 - Sensor-Surface: 4mm (Mechanical Surface Detection)
 - Electronics: DAE4 Sn869; Calibrated: 2010-09-21
 - Phantom: SAM 1800/1900 MHz; Type: SAM

WCDMA Body 9538/Area Scan (61x91x1): Measurement grid: dx=15mm, dy=15mm

[Info: Interpolated medium parameters used for SAR evaluation.](#)
 Maximum value of SAR (interpolated) = 1.21 mW/g

WCDMA Body 9538/Zoom Scan (5x5x7)/Cube 0: Measurement grid: dx=8mm, dy=8mm, dz=5mm
 Reference Value = 11.0 V/m; Power Drift = 0.038 dB
 Peak SAR (extrapolated) = 1.69 W/kg
SAR(1 g) = 1.07 mW/g; SAR(10 g) = 0.571 mW/g

[Info: Interpolated medium parameters used for SAR evaluation.](#)
 Maximum value of SAR (measured) = 1.21 mW/g

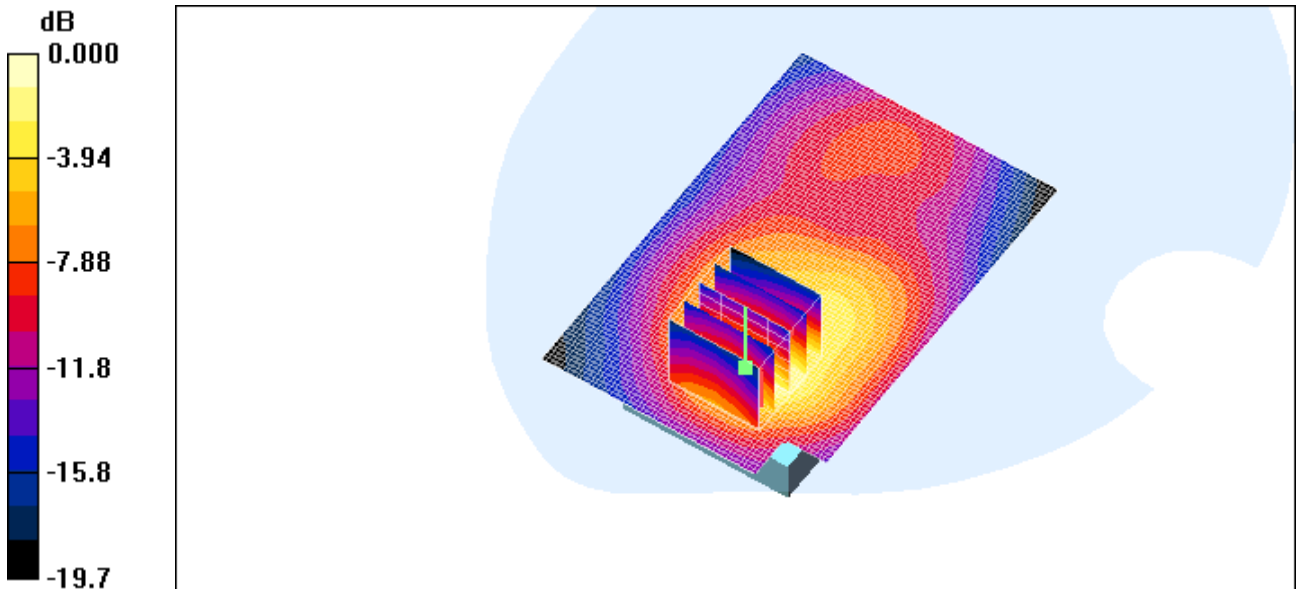

0 dB = 1.21mW/g

Test Laboratory: HCT CO., LTD
EUT Type: GSM/WCDMA Phone with Bluetooth & WLAN
GPRS Class10 and GPRS mode class B(GPRS and GSM, but not simultaneously)
Liquid Temperature: 21.3 °C
Ambient Temperature: 21.5 °C
Test Date: Mar.21, 2011

DUT: P8000; Type: Bar side; Serial: #1

Communication System: WCDMA1900(FCC); Frequency: 1880 MHz;Duty Cycle: 1:1
Medium parameters used: $f = 1880$ MHz; $\sigma = 1.57$ mho/m; $\epsilon_r = 53.5$; $\rho = 1000$ kg/m³
Phantom section: Flat Section ; Measurement SW: DASY4, V4.7 Build 80; Postprocessing SW: SEMCAD, V1.8 Build 184

DASY4 Configuration:

- Probe: ET3DV6 - SN1630; ConvF(4.55, 4.55, 4.55); Calibrated: 2010-05-25
- Sensor-Surface: 4mm (Mechanical Surface Detection)
- Electronics: DAE4 Sn869; Calibrated: 2010-09-21
- Phantom: SAM 1800/1900 MHz; Type: SAM

Body 9400/Area Scan (31x101x1): Measurement grid: dx=15mm, dy=15mm
Maximum value of SAR (interpolated) = 0.188 mW/g

Body 9400/Zoom Scan (5x5x7)/Cube 0: Measurement grid: dx=8mm, dy=8mm, dz=5mm
Reference Value = 7.01 V/m; Power Drift = 0.164 dB
Peak SAR (extrapolated) = 0.245 W/kg
SAR(1 g) = 0.166 mW/g; SAR(10 g) = 0.105 mW/g
Maximum value of SAR (measured) = 0.179 mW/g

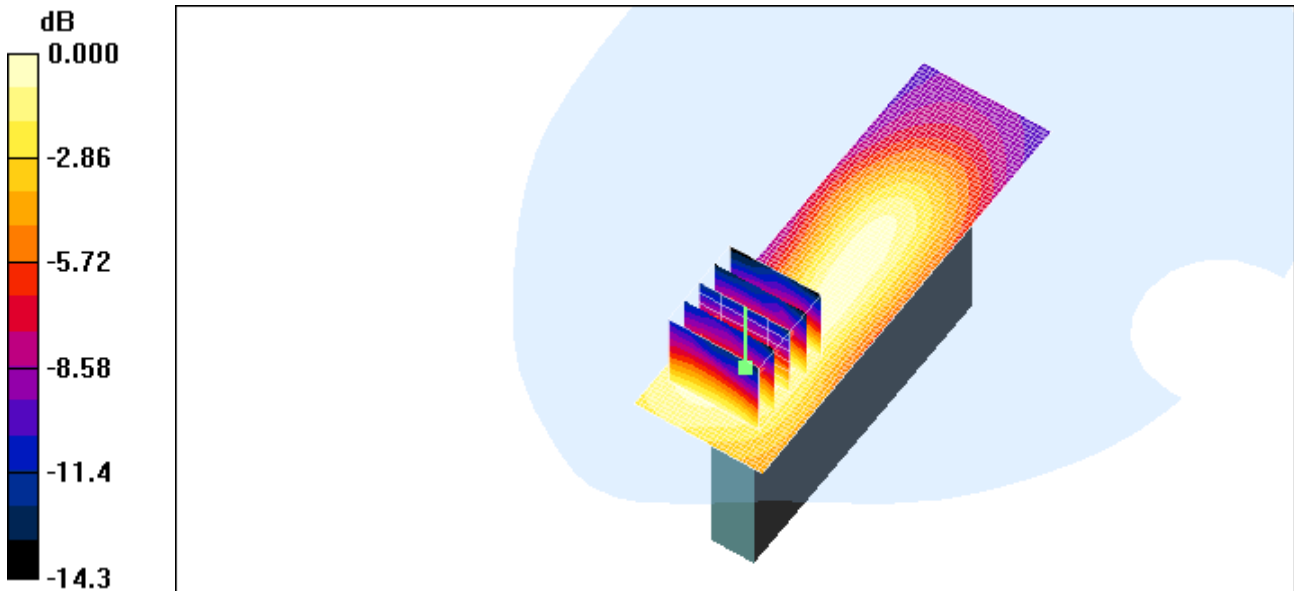

0 dB = 0.179mW/g

Test Laboratory: HCT CO., LTD
EUT Type: GSM/WCDMA Phone with Bluetooth & WLAN
GPRS Class10 and GPRS mode class B(GPRS and GSM, but not simultaneously)
Liquid Temperature: 21.3 °C
Ambient Temperature: 21.5 °C
Test Date: Mar.21, 2011

DUT: P8000; Type: Bar side; Serial: #1

Communication System: WCDMA1900(FCC); Frequency: 1880 MHz;Duty Cycle: 1:1
Medium parameters used: $f = 1880$ MHz; $\sigma = 1.57$ mho/m; $\epsilon_r = 53.5$; $\rho = 1000$ kg/m³
Phantom section: Flat Section ; Measurement SW: DASY4, V4.7 Build 80; Postprocessing SW: SEMCAD, V1.8 Build 184

DASY4 Configuration:

- Probe: ET3DV6 - SN1630; ConvF(4.55, 4.55, 4.55); Calibrated: 2010-05-25
- Sensor-Surface: 4mm (Mechanical Surface Detection)
- Electronics: DAE4 Sn869; Calibrated: 2010-09-21
- Phantom: SAM 1800/1900 MHz; Type: SAM

Body 9400/Area Scan (31x101x1): Measurement grid: dx=15mm, dy=15mm
Maximum value of SAR (interpolated) = 0.180 mW/g

Body 9400/Zoom Scan (5x5x7)/Cube 0: Measurement grid: dx=8mm, dy=8mm, dz=5mm
Reference Value = 10.6 V/m; Power Drift = 0.096 dB
Peak SAR (extrapolated) = 0.255 W/kg
SAR(1 g) = 0.168 mW/g; SAR(10 g) = 0.102 mW/g
Maximum value of SAR (measured) = 0.184 mW/g

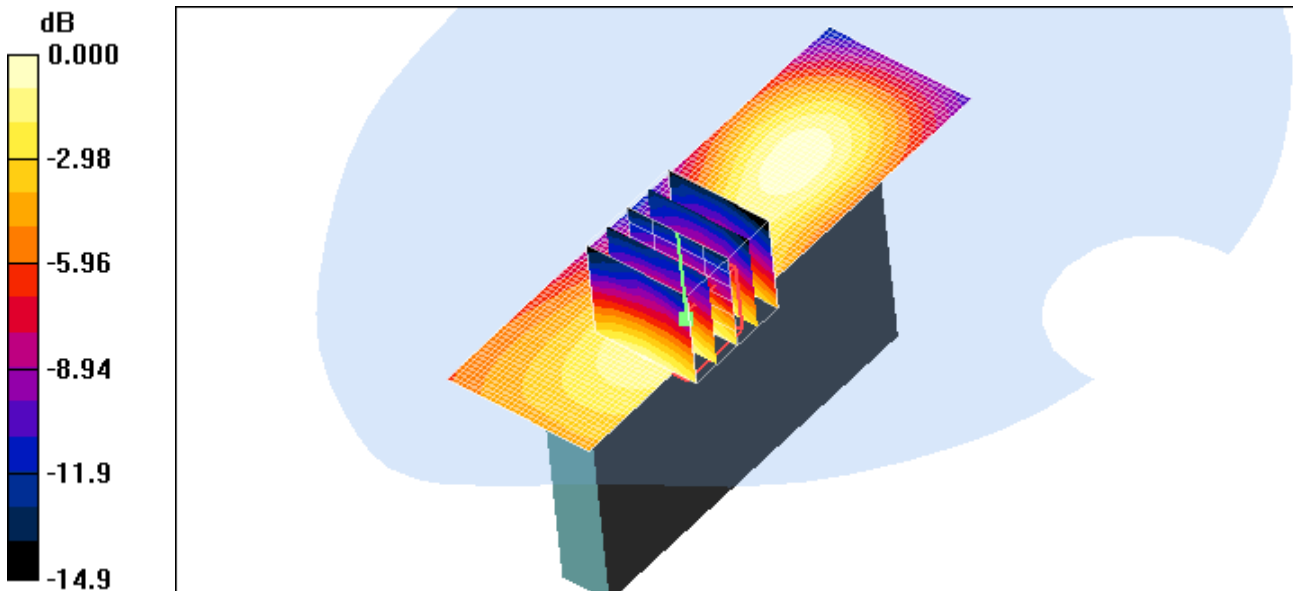

0 dB = 0.184mW/g

Test Laboratory: HCT CO., LTD
 EUT Type: GSM/WCDMA Phone with Bluetooth & WLAN
 GPRS Class10 and GPRS mode class B(GPRS and GSM, but not simultaneously)
 Liquid Temperature: 21.3 °C
 Ambient Temperature: 21.5 °C
 Test Date: Mar.21, 2011

DUT: P8000; Type: Bar top; Serial: #1

Communication System: WCDMA1900(FCC); Frequency: 1852.4 MHz; Duty Cycle: 1:1
 Medium parameters used (interpolated): $f = 1852.4 \text{ MHz}$; $\sigma = 1.54 \text{ mho/m}$; $\epsilon_r = 53.7$; $\rho = 1000 \text{ kg/m}^3$
 Phantom section: Flat Section ; Measurement SW: DASY4, V4.7 Build 80; Postprocessing SW: SEMCAD, V1.8 Build 184

DASY4 Configuration:
 - Probe: ET3DV6 - SN1630; ConvF(4.55, 4.55, 4.55); Calibrated: 2010-05-25
 - Sensor-Surface: 4mm (Mechanical Surface Detection)
 - Electronics: DAE4 Sn869; Calibrated: 2010-09-21
 - Phantom: SAM 1800/1900 MHz; Type: SAM

Body 9262/Area Scan (41x61x1): Measurement grid: dx=15mm, dy=15mm

[Info: Interpolated medium parameters used for SAR evaluation.](#)
 Maximum value of SAR (interpolated) = 1.14 mW/g

Body 9262/Zoom Scan (5x5x7)/Cube 0: Measurement grid: dx=8mm, dy=8mm, dz=5mm
 Reference Value = 24.6 V/m; Power Drift = 0.067 dB
 Peak SAR (extrapolated) = 1.78 W/kg
SAR(1 g) = 1.07 mW/g; SAR(10 g) = 0.530 mW/g

[Info: Interpolated medium parameters used for SAR evaluation.](#)
 Maximum value of SAR (measured) = 1.18 mW/g

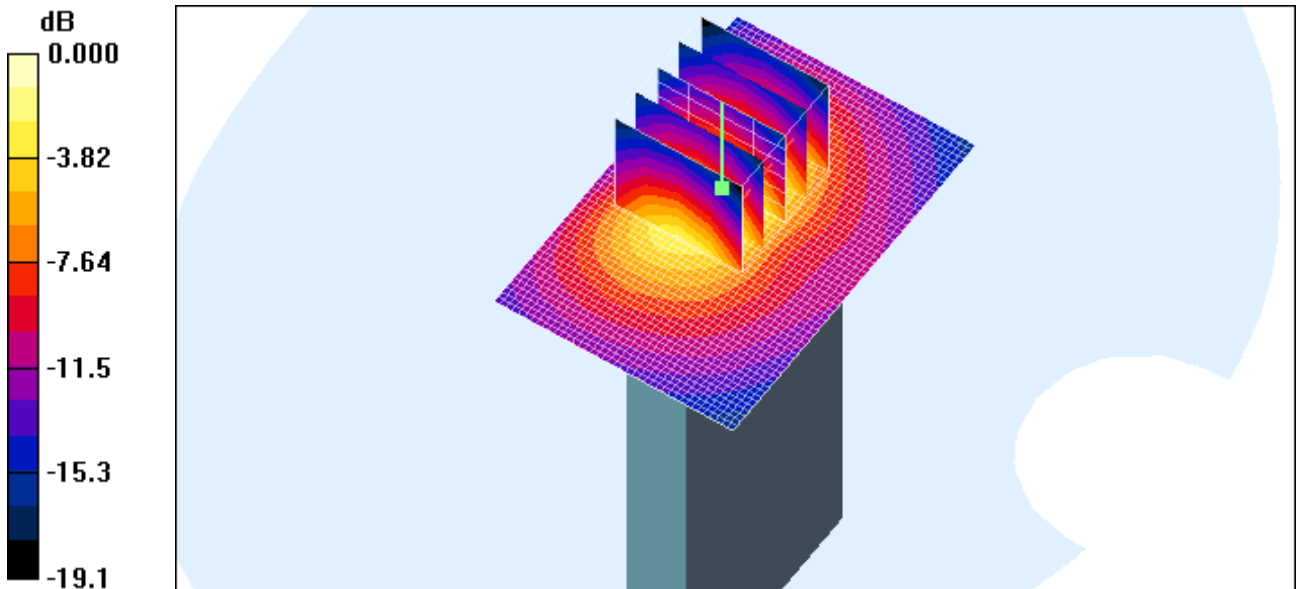

0 dB = 1.18mW/g

Test Laboratory: HCT CO., LTD
 EUT Type: GSM/WCDMA Phone with Bluetooth & WLAN
 GPRS Class10 and GPRS mode class B(GPRS and GSM, but not simultaneously)
 Liquid Temperature: 21.3 °C
 Ambient Temperature: 21.5 °C
 Test Date: Mar.21, 2011

DUT: P8000; Type: Bar top; Serial: #1

Communication System: WCDMA1900(FCC); Frequency: 1880 MHz;Duty Cycle: 1:1
 Medium parameters used: $f = 1880 \text{ MHz}$; $\sigma = 1.57 \text{ mho/m}$; $\epsilon_r = 53.5$; $\rho = 1000 \text{ kg/m}^3$
 Phantom section: Flat Section ; Measurement SW: DASY4, V4.7 Build 80; Postprocessing SW: SEMCAD, V1.8 Build 184

DASY4 Configuration:
 - Probe: ET3DV6 - SN1630; ConvF(4.55, 4.55, 4.55); Calibrated: 2010-05-25
 - Sensor-Surface: 4mm (Mechanical Surface Detection)
 - Electronics: DAE4 Sn869; Calibrated: 2010-09-21
 - Phantom: SAM 1800/1900 MHz; Type: SAM

Body 9400/Area Scan (41x61x1): Measurement grid: dx=15mm, dy=15mm
 Maximum value of SAR (interpolated) = 1.24 mW/g

Body 9400/Zoom Scan (5x5x7)/Cube 0: Measurement grid: dx=8mm, dy=8mm, dz=5mm
 Reference Value = 24.7 V/m; Power Drift = 0.056 dB
 Peak SAR (extrapolated) = 1.86 W/kg
SAR(1 g) = 1.14 mW/g; SAR(10 g) = 0.574 mW/g
 Maximum value of SAR (measured) = 1.28 mW/g

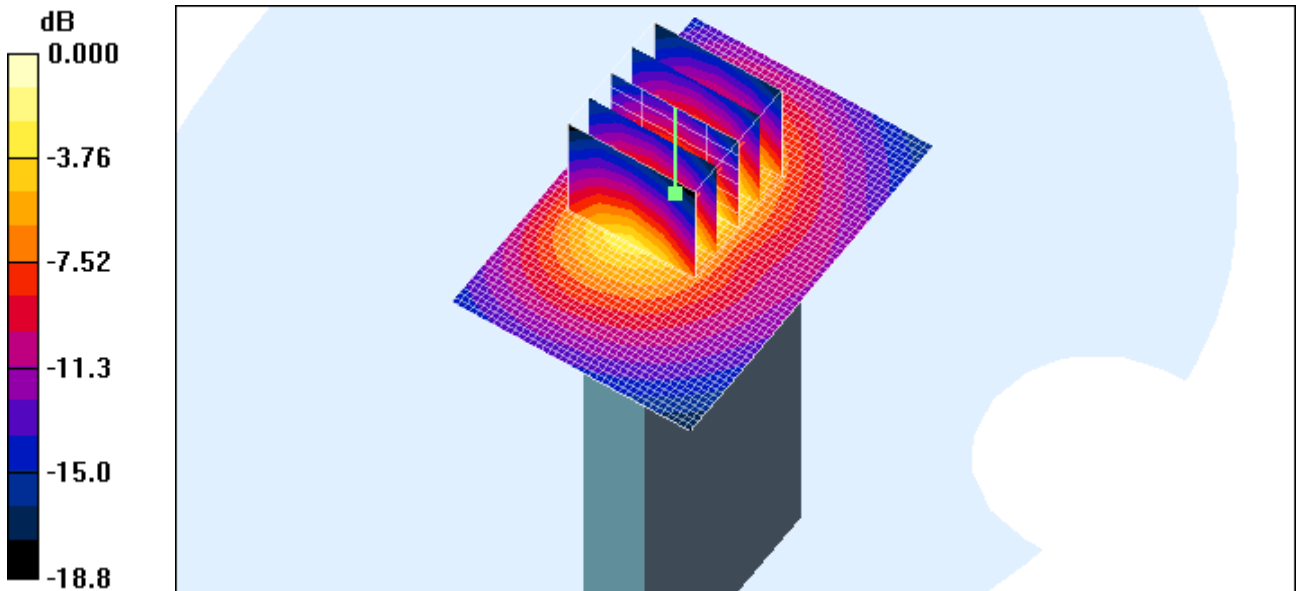

0 dB = 1.28mW/g

Test Laboratory: HCT CO., LTD
EUT Type: GSM/WCDMA Phone with Bluetooth & WLAN
GPRS Class10 and GPRS mode class B(GPRS and GSM, but not simultaneously)
Liquid Temperature: 21.3 °C
Ambient Temperature: 21.5 °C
Test Date: Mar.21, 2011

DUT: P8000; Type: Bar top; Serial: #1

Communication System: WCDMA1900(FCC); Frequency: 1907.6 MHz; Duty Cycle: 1:1
Medium parameters used (interpolated): $f = 1907.6$ MHz; $\sigma = 1.59$ mho/m; $\epsilon_r = 53.2$; $\rho = 1000$ kg/m³
Phantom section: Flat Section ; Measurement SW: DASY4, V4.7 Build 80; Postprocessing SW: SEMCAD, V1.8 Build 184

DASY4 Configuration:

- Probe: ET3DV6 - SN1630; ConvF(4.55, 4.55, 4.55); Calibrated: 2010-05-25
- Sensor-Surface: 4mm (Mechanical Surface Detection)
- Electronics: DAE4 Sn869; Calibrated: 2010-09-21
- Phantom: SAM 1800/1900 MHz; Type: SAM

Body 9538/Area Scan (41x61x1): Measurement grid: dx=15mm, dy=15mm

[Info: Interpolated medium parameters used for SAR evaluation.](#)

Maximum value of SAR (interpolated) = 1.15 mW/g

Body 9538/Zoom Scan (5x5x7)/Cube 0: Measurement grid: dx=8mm, dy=8mm, dz=5mm

Reference Value = 24.3 V/m; Power Drift = 0.077 dB

Peak SAR (extrapolated) = 1.63 W/kg

SAR(1 g) = 1.03 mW/g; SAR(10 g) = 0.544 mW/g

[Info: Interpolated medium parameters used for SAR evaluation.](#)

Maximum value of SAR (measured) = 1.13 mW/g

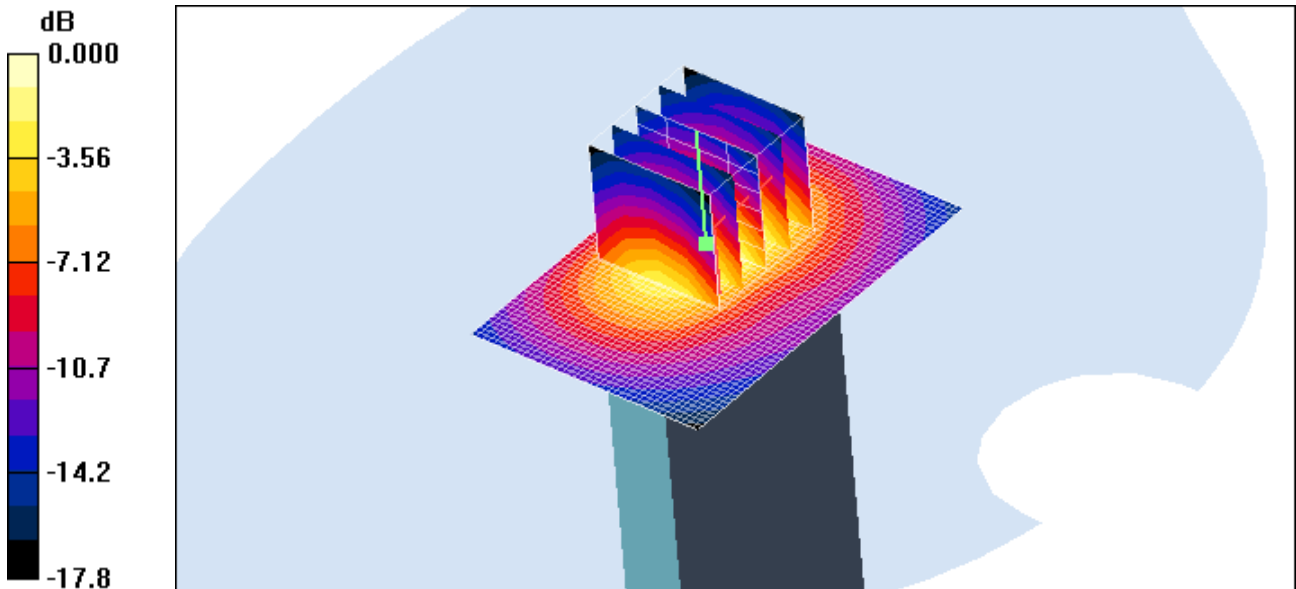

0 dB = 1.13mW/g

Test Laboratory: HCT CO., LTD
EUT Type: GSM/WCDMA Phone with Bluetooth & WLAN
GPRS Class10 and GPRS mode class B(GPRS and GSM, but not simultaneously)
Liquid Temperature: 21.3 °C
Ambient Temperature: 21.5 °C
Test Date: Mar.21, 2011

DUT: P8000; Type: Bar; Serial: #1

Communication System: 2450MHz FCC; Frequency: 2462 MHz;Duty Cycle: 1:1
Medium parameters used (interpolated): $f = 2462$ MHz; $\sigma = 1.97$ mho/m; $\epsilon_r = 51.6$; $\rho = 1000$ kg/m³
Phantom section: Flat Section ; Measurement SW: DASY4, V4.7 Build 80; Postprocessing SW: SEMCAD, V1.8 Build 184

DASY4 Configuration:

- Probe: ET3DV6 - SN1630; ConvF(4.15, 4.15, 4.15); Calibrated: 2010-05-25
- Sensor-Surface: 4mm (Mechanical Surface Detection)
- Electronics: DAE4 Sn869; Calibrated: 2010-09-21
- Phantom: SAM 1800/1900 MHz; Type: SAM

802.11b 11ch/Area Scan (61x91x1): Measurement grid: dx=15mm, dy=15mm

[Info: Interpolated medium parameters used for SAR evaluation.](#)

Maximum value of SAR (interpolated) = 0.076 mW/g

802.11b 11ch/Zoom Scan (5x5x7)/Cube 0: Measurement grid: dx=8mm, dy=8mm, dz=5mm

Reference Value = 6.06 V/m; Power Drift = 0.098 dB

Peak SAR (extrapolated) = 0.195 W/kg

SAR(1 g) = 0.074 mW/g; SAR(10 g) = 0.035 mW/g

Maximum value of SAR (measured) = 0.075 mW/g

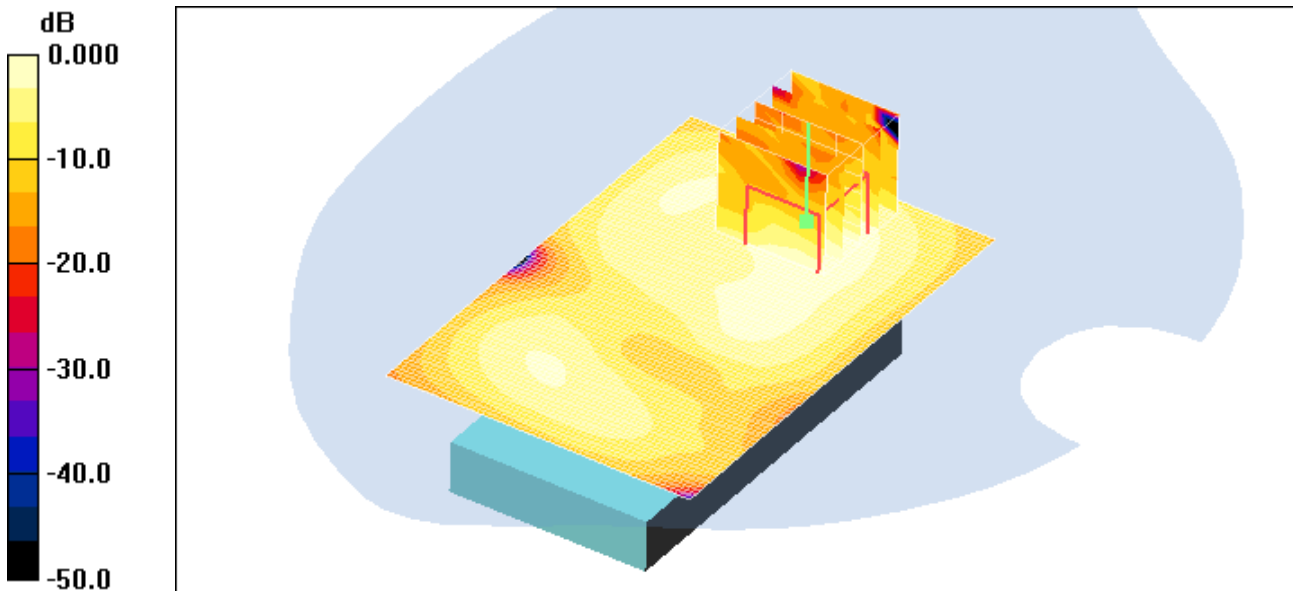

0 dB = 0.075mW/g

Test Laboratory: HCT CO., LTD
EUT Type: GSM/WCDMA Phone with Bluetooth & WLAN
GPRS Class10 and GPRS mode class B(GPRS and GSM, but not simultaneously)
Liquid Temperature: 21.3 °C
Ambient Temperature: 21.5 °C
Test Date: Mar.21, 2011

DUT: P8000; Type: Bar; Serial: #1

Communication System: 2450MHz FCC; Frequency: 2462 MHz;Duty Cycle: 1:1
Medium parameters used (interpolated): $f = 2462$ MHz; $\sigma = 1.97$ mho/m; $\epsilon_r = 51.6$; $\rho = 1000$ kg/m³
Phantom section: Flat Section ; Measurement SW: DASY4, V4.7 Build 80; Postprocessing SW: SEMCAD, V1.8 Build 184

DASY4 Configuration:

- Probe: ET3DV6 - SN1630; ConvF(4.15, 4.15, 4.15); Calibrated: 2010-05-25
- Sensor-Surface: 4mm (Mechanical Surface Detection)
- Electronics: DAE4 Sn869; Calibrated: 2010-09-21
- Phantom: SAM 1800/1900 MHz; Type: SAM

802.11b 11ch/Area Scan (61x91x1): Measurement grid: dx=15mm, dy=15mm

[Info: Interpolated medium parameters used for SAR evaluation.](#)

Maximum value of SAR (interpolated) = 0.354 mW/g

802.11b 11ch/Zoom Scan (5x5x7)/Cube 0: Measurement grid: dx=8mm, dy=8mm, dz=5mm

Reference Value = 8.87 V/m; Power Drift = 0.02 dB

Peak SAR (extrapolated) = 0.788 W/kg

SAR(1 g) = 0.343 mW/g; SAR(10 g) = 0.169 mW/g

[Info: Interpolated medium parameters used for SAR evaluation.](#)

Maximum value of SAR (measured) = 0.358 mW/g

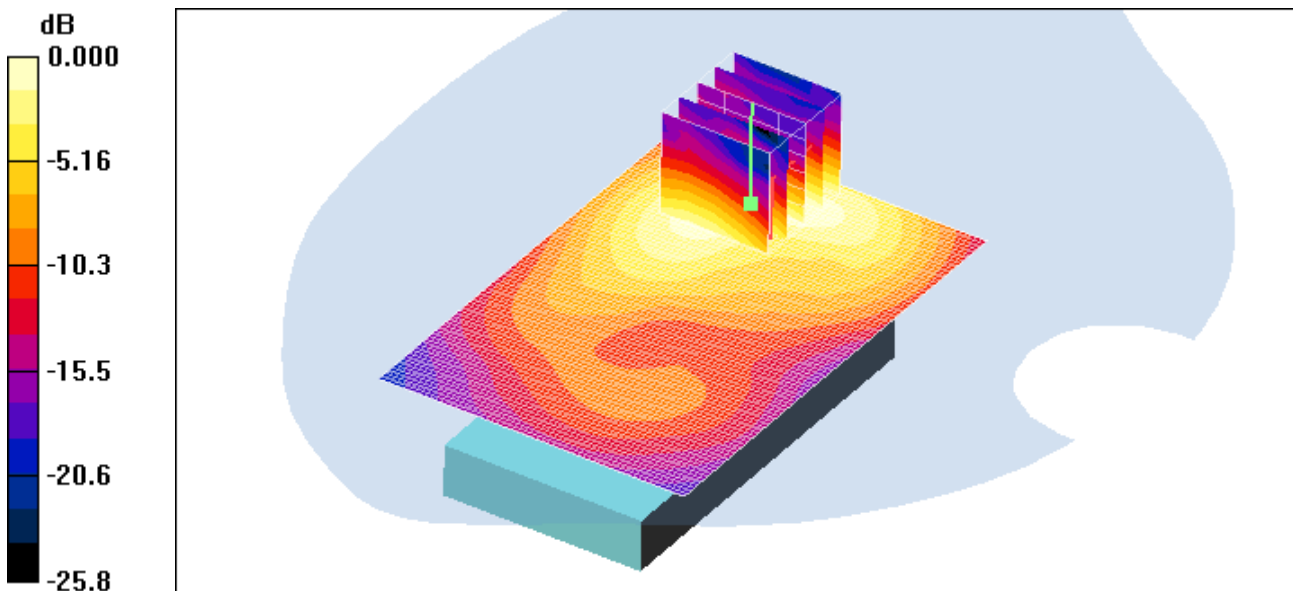

0 dB = 0.358mW/g

Test Laboratory: HCT CO., LTD
EUT Type: GSM/WCDMA Phone with Bluetooth & WLAN
GPRS Class10 and GPRS mode class B(GPRS and GSM, but not simultaneously)
Liquid Temperature: 21.3 °C
Ambient Temperature: 21.5 °C
Test Date: Mar.21, 2011

DUT: P8000; Type: Bar side; Serial: #1

Communication System: 2450MHz FCC; Frequency: 2462 MHz;Duty Cycle: 1:1
Medium parameters used (interpolated): $f = 2462$ MHz; $\sigma = 1.97$ mho/m; $\epsilon_r = 51.6$; $\rho = 1000$ kg/m³
Phantom section: Flat Section ; Measurement SW: DASY4, V4.7 Build 80; Postprocessing SW: SEMCAD, V1.8 Build 184

DASY4 Configuration:

- Probe: ET3DV6 - SN1630; ConvF(4.15, 4.15, 4.15); Calibrated: 2010-05-25
- Sensor-Surface: 4mm (Mechanical Surface Detection)
- Electronics: DAE4 Sn869; Calibrated: 2010-09-21
- Phantom: SAM 1800/1900 MHz; Type: SAM

Body 11/Area Scan (31x101x1): Measurement grid: dx=15mm, dy=15mm

[Info: Interpolated medium parameters used for SAR evaluation.](#)

Maximum value of SAR (interpolated) = 0.039 mW/g

Body 11/Zoom Scan (5x5x7)/Cube 0: Measurement grid: dx=8mm, dy=8mm, dz=5mm

Reference Value = 4.12 V/m; Power Drift = 0.020 dB

Peak SAR (extrapolated) = 0.105 W/kg

SAR(1 g) = 0.034 mW/g; SAR(10 g) = 0.016 mW/g

Maximum value of SAR (measured) = 0.037 mW/g

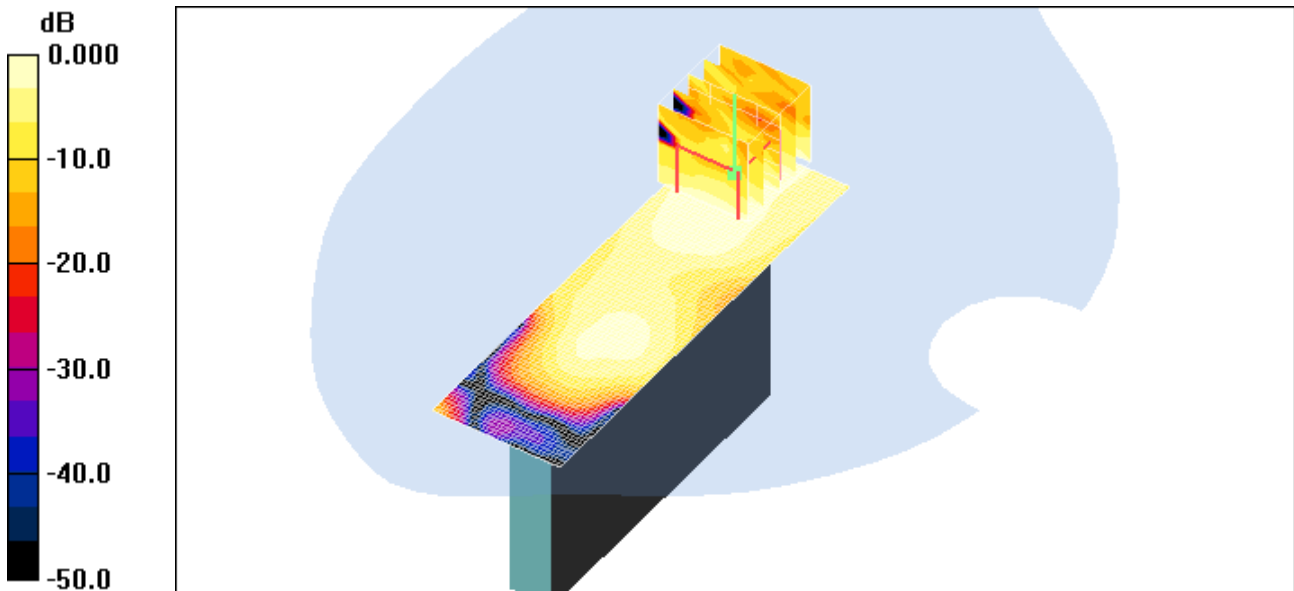

0 dB = 0.037mW/g

Test Laboratory: HCT CO., LTD
 EUT Type: GSM/WCDMA Phone with Bluetooth & WLAN
 GPRS Class10 and GPRS mode class B(GPRS and GSM, but not simultaneously)
 Liquid Temperature: 21.3 °C
 Ambient Temperature: 21.5 °C
 Test Date: Mar.21, 2011

DUT: P8000; Type: Bar top; Serial: #1

Communication System: 2450MHz FCC; Frequency: 2462 MHz;Duty Cycle: 1:1
 Medium parameters used: $\sigma = 1.96195$ mho/m, $\epsilon_r = 51.5987$; $\rho = 1000$ kg/m³ Medium parameters used
 (interpolated): $f = 2462$ MHz; $\sigma = 1.97$ mho/m; $\epsilon_r = 51.6$; $\rho = 1000$ kg/m³
 Phantom section: Flat Section ; Measurement SW: DASY4, V4.7 Build 80; Postprocessing SW: SEMCAD, V1.8
 Build 184

DASY4 Configuration:
 - Probe: ET3DV6 - SN1630; ConvF(4.15, 4.15, 4.15); Calibrated: 2010-05-25
 - Sensor-Surface: 4mm (Mechanical Surface Detection)
 - Electronics: DAE4 Sn869; Calibrated: 2010-09-21
 - Phantom: SAM 1800/1900 MHz; Type: SAM

Body 11/Area Scan (41x61x1): Measurement grid: dx=15mm, dy=15mm
 Maximum value of Total (interpolated) = 10.1 V/m

Body 11/Zoom Scan (5x5x7)/Cube 0: Measurement grid: dx=8mm, dy=8mm, dz=5mm
 Reference Value = 9.92 V/m; Power Drift = 0.158 dB
 Peak SAR (extrapolated) = 0.531 W/kg
SAR(1 g) = 0.187 mW/g; SAR(10 g) = 0.082 mW/g

[Info: Interpolated medium parameters used for SAR evaluation.](#)
 Maximum value of SAR (measured) = 0.199 mW/g

Body 11/Area Scan (41x61x1): Measurement grid: dx=15mm, dy=15mm

[Info: Interpolated medium parameters used for SAR evaluation.](#)
 Maximum value of SAR (interpolated) = 0.189 mW/g

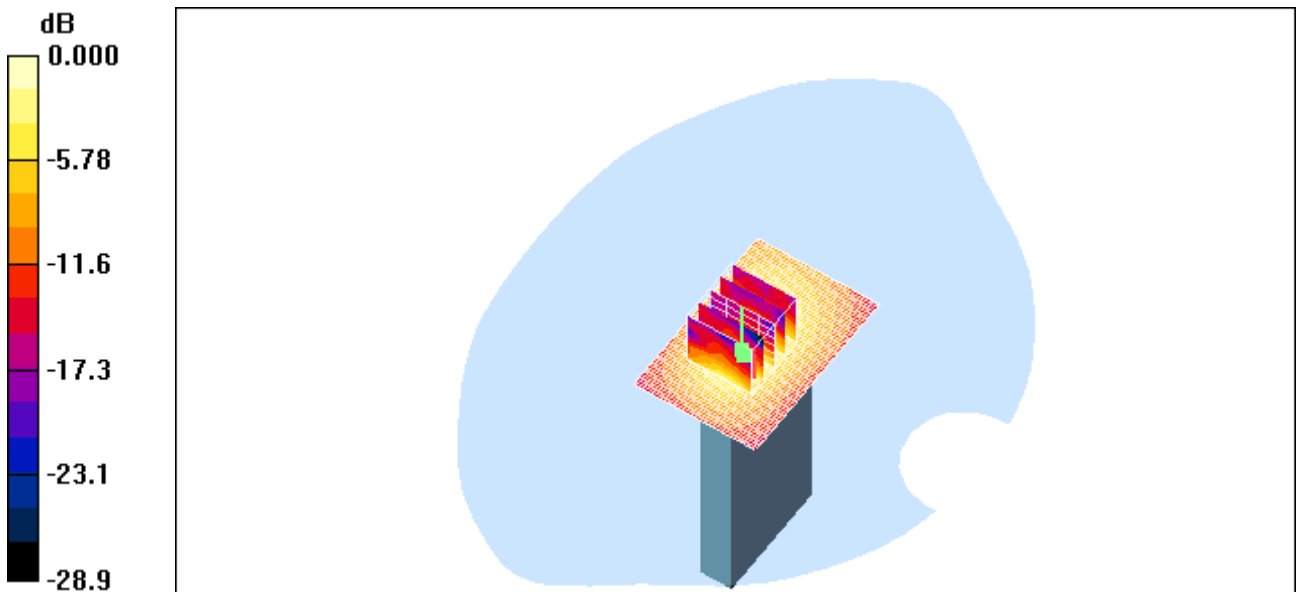

0 dB = 0.199V/m

Test Laboratory: HCT CO., LTD
 EUT Type: GSM/WCDMA Phone with Bluetooth & WLAN
 GPRS Class10 and GPRS mode class B(GPRS and GSM, but not simultaneously)
 Liquid Temperature: 21.2 °C
 Ambient Temperature: 21.4 °C
 Test Date: Mar.20, 2011

DUT: P8000; Type: Bar; Serial: #1

Communication System: GSM 850; Frequency: 824.2 MHz; Duty Cycle: 1:4.15
 Medium parameters used: $f = 825$ MHz; $\sigma = 0.971$ mho/m; $\epsilon_r = 56.9$; $\rho = 1000$ kg/m³
 Phantom section: Flat Section ; Measurement SW: DASY4, V4.7 Build 80; Postprocessing SW: SEMCAD, V1.8 Build 184

DASY4 Configuration:
 - Probe: ET3DV6 - SN1630; ConvF(6.17, 6.17, 6.17); Calibrated: 2010-05-25
 - Sensor-Surface: 4mm (Mechanical Surface Detection)
 - Electronics: DAE4 Sn869; Calibrated: 2010-09-21
 - Phantom: 835/900 Phantom ; Type: SAM

GSM Body 128/Area Scan (61x91x1): Measurement grid: dx=15mm, dy=15mm
 Maximum value of SAR (interpolated) = 1.35 mW/g

GSM Body 128/Zoom Scan (5x5x7)/Cube 0: Measurement grid: dx=8mm, dy=8mm, dz=5mm
 Reference Value = 16.4 V/m; Power Drift = 0.005 dB
 Peak SAR (extrapolated) = 1.56 W/kg
SAR(1 g) = 1.24 mW/g; SAR(10 g) = 0.909 mW/g
 Maximum value of SAR (measured) = 1.31 mW/g

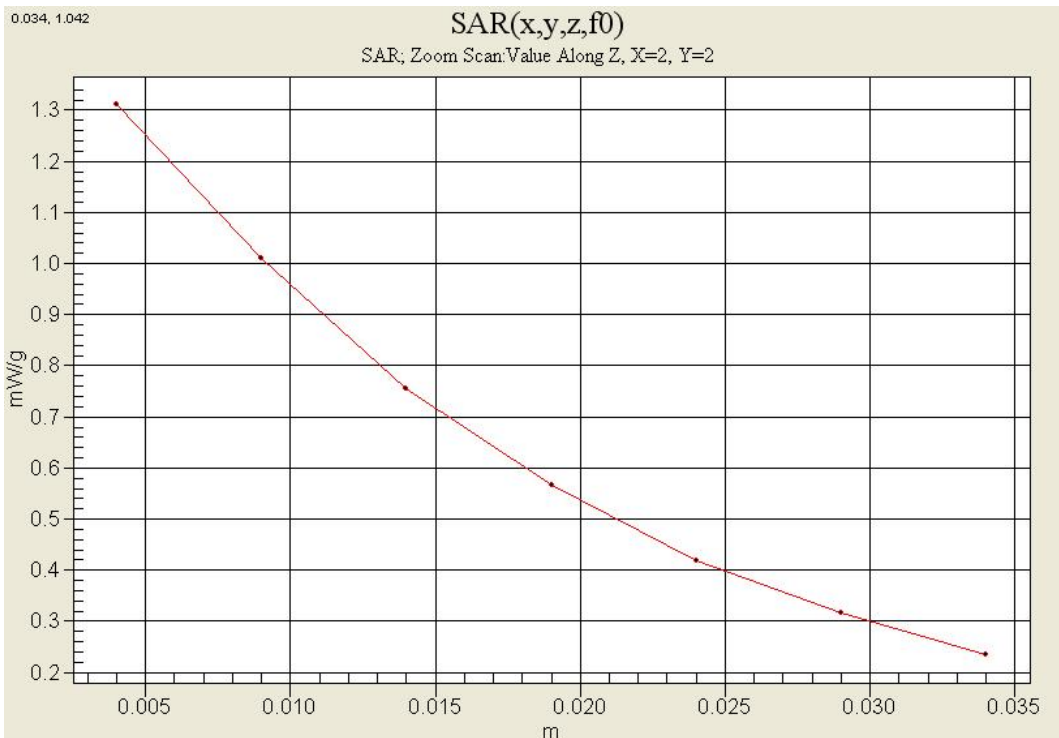

Test Laboratory: HCT CO., LTD
 EUT Type: GSM/WCDMA Phone with Bluetooth & WLAN
 GPRS Class10 and GPRS mode class B(GPRS and GSM, but not simultaneously)
 Liquid Temperature: 21.3 °C
 Ambient Temperature: 21.5 °C
 Test Date: Mar.21, 2011

DUT: P8000; Type: Bar; Serial: #1

Communication System: GSM 1900; Frequency: 1909.8 MHz; Duty Cycle: 1:4.15
 Medium parameters used: $f = 1910$ MHz; $\sigma = 1.59$ mho/m; $\epsilon_r = 53.2$; $\rho = 1000$ kg/m³
 Phantom section: Flat Section ; Measurement SW: DASY4, V4.7 Build 80; Postprocessing SW: SEMCAD, V1.8 Build 184

DASY4 Configuration:
 - Probe: ET3DV6 - SN1630; ConvF(4.55, 4.55, 4.55); Calibrated: 2010-05-25
 - Sensor-Surface: 4mm (Mechanical Surface Detection)
 - Electronics: DAE4 Sn869; Calibrated: 2010-09-21
 - Phantom: SAM 1800/1900 MHz; Type: SAM

PCS Body 810/Area Scan (61x91x1): Measurement grid: dx=15mm, dy=15mm
 Maximum value of SAR (interpolated) = 1.16 mW/g

PCS Body 810/Zoom Scan (5x5x7)/Cube 0: Measurement grid: dx=8mm, dy=8mm, dz=5mm
 Reference Value = 10.7 V/m; Power Drift = -0.179 dB
 Peak SAR (extrapolated) = 1.59 W/kg
SAR(1 g) = 0.996 mW/g; SAR(10 g) = 0.525 mW/g
 Maximum value of SAR (measured) = 1.13 mW/g

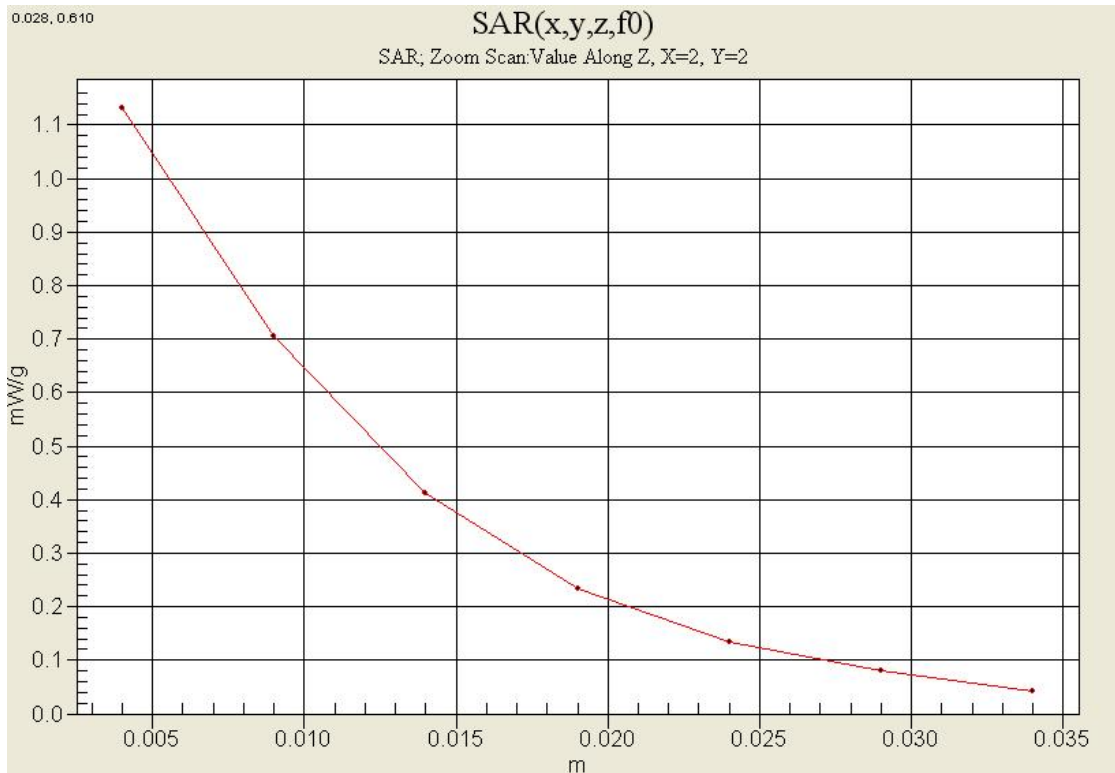

Test Laboratory: HCT CO., LTD
 EUT Type: GSM/WCDMA Phone with Bluetooth & WLAN
 GPRS Class10 and GPRS mode class B(GPRS and GSM, but not simultaneously)
 Liquid Temperature: 21.2 °C
 Ambient Temperature: 21.4 °C
 Test Date: Mar.20, 2011

DUT: P8000; Type: Bar; Serial: #1

Communication System: WCDMA850; Frequency: 836.6 MHz; Duty Cycle: 1:1
 Medium parameters used (interpolated): $f = 836.6 \text{ MHz}$; $\sigma = 0.982 \text{ mho/m}$; $\epsilon_r = 56.8$; $\rho = 1000 \text{ kg/m}^3$
 Phantom section: Flat Section ; Measurement SW: DASY4, V4.7 Build 80; Postprocessing SW: SEMCAD, V1.8 Build 184

DASY4 Configuration:
 - Probe: ET3DV6 - SN1630; ConvF(6.17, 6.17, 6.17); Calibrated: 2010-05-25
 - Sensor-Surface: 4mm (Mechanical Surface Detection)
 - Electronics: DAE4 Sn869; Calibrated: 2010-09-21
 - Phantom: 835/900 Phantom ; Type: SAM

Body 4183/Area Scan (61x91x1): Measurement grid: dx=15mm, dy=15mm

[Info: Interpolated medium parameters used for SAR evaluation.](#)
 Maximum value of SAR (interpolated) = 0.663 mW/g

Body 4183/Zoom Scan (5x5x7)/Cube 0: Measurement grid: dx=8mm, dy=8mm, dz=5mm
 Reference Value = 15.9 V/m; Power Drift = -0.089 dB
 Peak SAR (extrapolated) = 0.777 W/kg
SAR(1 g) = 0.617 mW/g; SAR(10 g) = 0.452 mW/g

[Info: Interpolated medium parameters used for SAR evaluation.](#)
 Maximum value of SAR (measured) = 0.652 mW/g

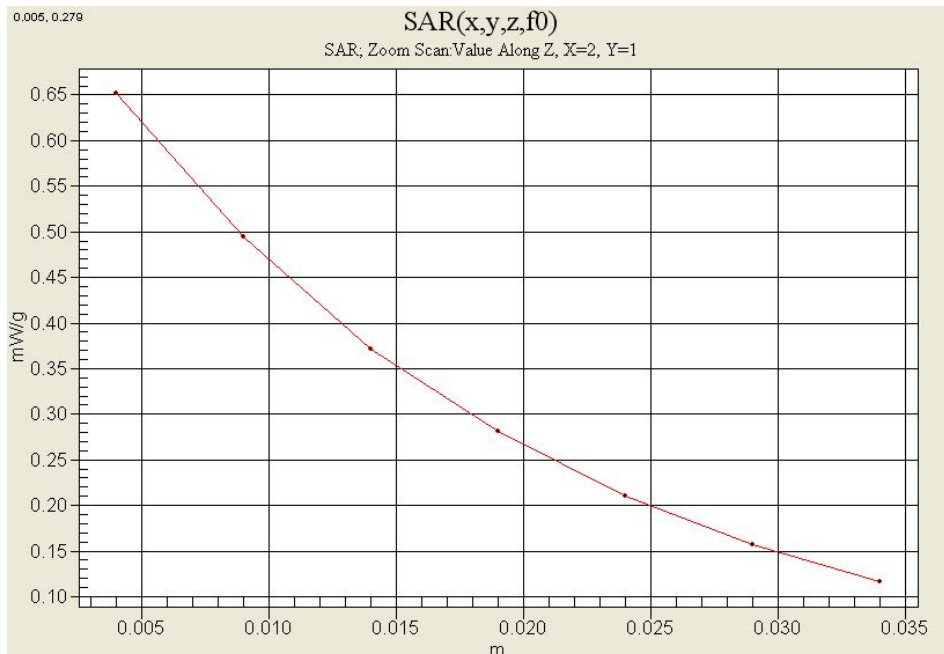

Test Laboratory: HCT CO., LTD
 EUT Type: GSM/WCDMA Phone with Bluetooth & WLAN
 GPRS Class10 and GPRS mode class B(GPRS and GSM, but not simultaneously)
 Liquid Temperature: 21.3 °C
 Ambient Temperature: 21.5 °C
 Test Date: Mar.21, 2011

DUT: P8000; Type: Bar; Serial: #1

Communication System: WCDMA1900(FCC); Frequency: 1880 MHz;Duty Cycle: 1:1
 Medium parameters used: $f = 1880 \text{ MHz}$; $\sigma = 1.57 \text{ mho/m}$; $\epsilon_r = 53.5$; $\rho = 1000 \text{ kg/m}^3$
 Phantom section: Flat Section ; Measurement SW: DASY4, V4.7 Build 80; Postprocessing SW: SEMCAD, V1.8 Build 184

DASY4 Configuration:

- Probe: ET3DV6 - SN1630; ConvF(4.55, 4.55, 4.55); Calibrated: 2010-05-25
- Sensor-Surface: 4mm (Mechanical Surface Detection)
- Electronics: DAE4 Sn869; Calibrated: 2010-09-21
- Phantom: SAM 1800/1900 MHz; Type: SAM

WCDMA Body 9400/Area Scan (61x91x1): Measurement grid: dx=15mm, dy=15mm
 Maximum value of SAR (interpolated) = 1.32 mW/g

WCDMA Body 9400/Zoom Scan (5x5x7)/Cube 0: Measurement grid: dx=8mm, dy=8mm, dz=5mm
 Reference Value = 12.0 V/m; Power Drift = 0.058 dB
 Peak SAR (extrapolated) = 1.84 W/kg
SAR(1 g) = 1.16 mW/g; SAR(10 g) = 0.615 mW/g
 Maximum value of SAR (measured) = 1.34 mW/g

WCDMA Body 9400/Zoom Scan (5x5x7)/Cube 1: Measurement grid: dx=8mm, dy=8mm, dz=5mm
 Reference Value = 12.0 V/m; Power Drift = 0.058 dB
 Peak SAR (extrapolated) = 1.34 W/kg
SAR(1 g) = 0.805 mW/g; SAR(10 g) = 0.459 mW/g
 Maximum value of SAR (measured) = 0.974 mW/g

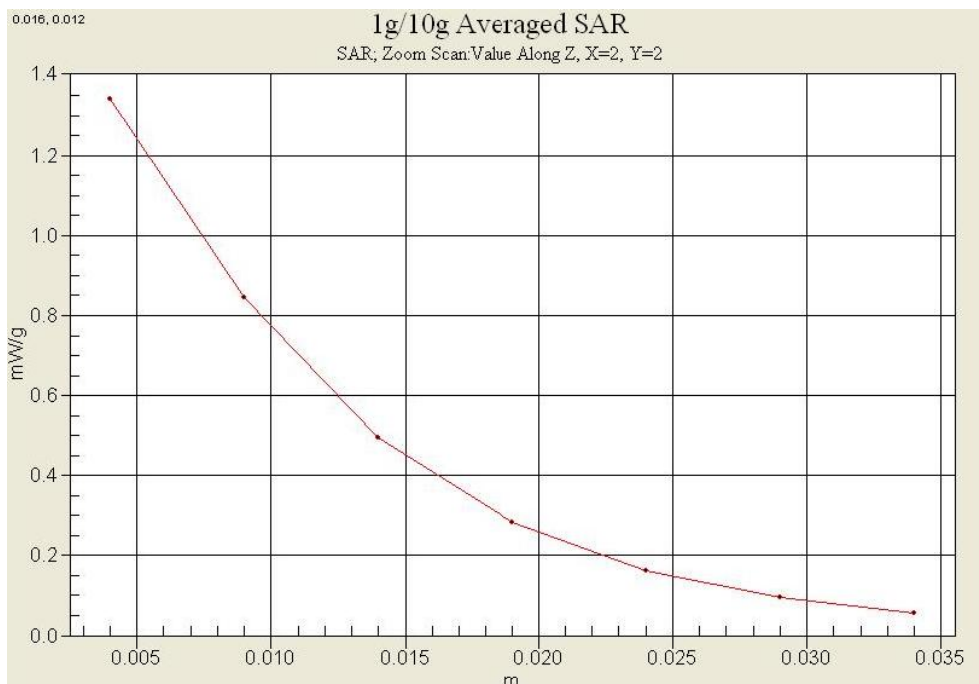

Test Laboratory: HCT CO., LTD
 EUT Type: GSM/WCDMA Phone with Bluetooth & WLAN
 GPRS Class10 and GPRS mode class B(GPRS and GSM, but not simultaneously)
 Liquid Temperature: 21.3 °C
 Ambient Temperature: 21.5 °C
 Test Date: Mar.21, 2011

DUT: P8000; Type: Bar; Serial: #1

Communication System: 2450MHz FCC; Frequency: 2462 MHz;Duty Cycle: 1:1
 Medium parameters used (interpolated): $f = 2462$ MHz; $\sigma = 1.97$ mho/m; $\epsilon_r = 51.6$; $\rho = 1000$ kg/m³
 Phantom section: Flat Section ; Measurement SW: DASY4, V4.7 Build 80; Postprocessing SW: SEMCAD, V1.8 Build 184

DASY4 Configuration:
 - Probe: ET3DV6 - SN1630; ConvF(4.15, 4.15, 4.15); Calibrated: 2010-05-25
 - Sensor-Surface: 4mm (Mechanical Surface Detection)
 - Electronics: DAE4 Sn869; Calibrated: 2010-09-21
 - Phantom: SAM 1800/1900 MHz; Type: SAM

802.11b 11ch/Area Scan (61x91x1): Measurement grid: dx=15mm, dy=15mm

[Info: Interpolated medium parameters used for SAR evaluation.](#)
 Maximum value of SAR (interpolated) = 0.354 mW/g

802.11b 11ch/Zoom Scan (5x5x7)/Cube 0: Measurement grid: dx=8mm, dy=8mm, dz=5mm
 Reference Value = 8.87 V/m; Power Drift = 0.02 dB
 Peak SAR (extrapolated) = 0.788 W/kg
SAR(1 g) = 0.343 mW/g; SAR(10 g) = 0.169 mW/g

[Info: Interpolated medium parameters used for SAR evaluation.](#)
 Maximum value of SAR (measured) = 0.358 mW/g

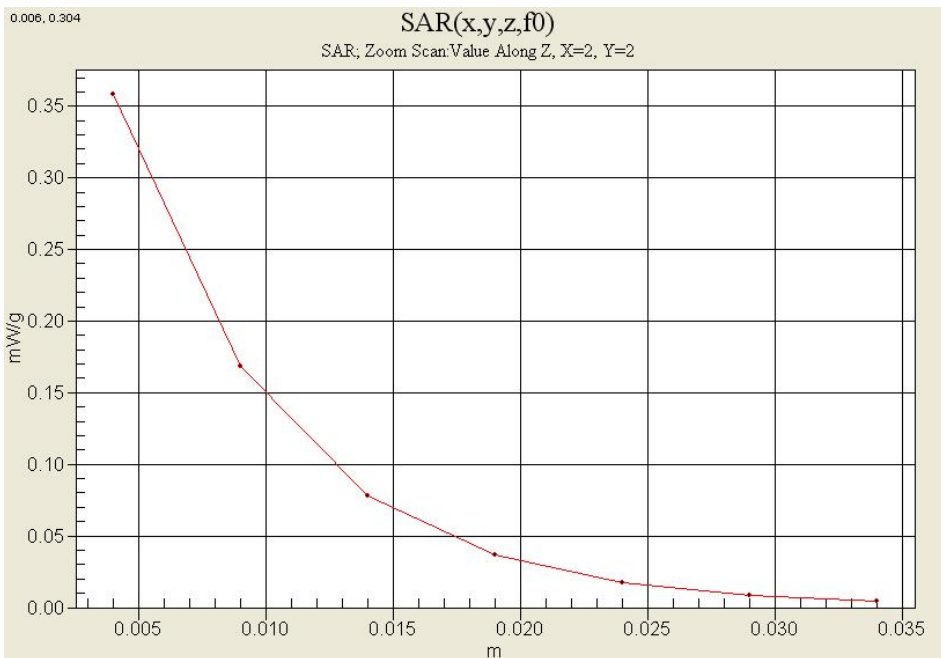

Attachment 2. – Dipole Validation Plots

■ Validation Data (835 MHz Head)

Test Laboratory: HCT CO., LTD
Input Power 100 mW (20 dBm)
Liquid Temp: 21.4 °C
Test Date: Nov.15, 2010

DUT: Dipole 835 MHz; Type: D835V2; Serial: D835V2 – SN:441

Communication System: CW; Frequency: 835 MHz; Duty Cycle: 1:1
Medium parameters used: $f = 835$ MHz; $\sigma = 0.889$ mho/m; $\epsilon_r = 42.1$; $\rho = 1000$ kg/m³
Phantom section: Flat Section ; Measurement SW: DASY4, V4.7 Build 80; Postprocessing SW: SEMCAD, V1.8 Build 184

DASY4 Configuration:

- Probe: ES3DV3 – SN3161; ConvF(5.96, 5.96, 5.96); Calibrated: 2010-03-22
- Sensor-Surface: 4mm (Mechanical Surface Detection)
- Electronics: DAE3 Sn446; Calibrated: 2010-09-21
- Phantom: SAM 835/900 MHz; Type: SAM

Validation 835 MHz/Area Scan (61x81x1): Measurement grid: dx=15mm, dy=15mm
Maximum value of SAR (interpolated) = 1.06 mW/g

Validation 835 MHz/Zoom Scan (5x5x7)/Cube 0: Measurement grid: dx=8mm, dy=8mm, dz=5mm
Reference Value = 34.7 V/m; Power Drift = -0.020 dB
Peak SAR (extrapolated) = 1.44 W/kg
SAR(1 g) = 0.975 mW/g; SAR(10 g) = 0.647 mW/g
Maximum value of SAR (measured) = 1.05 mW/g

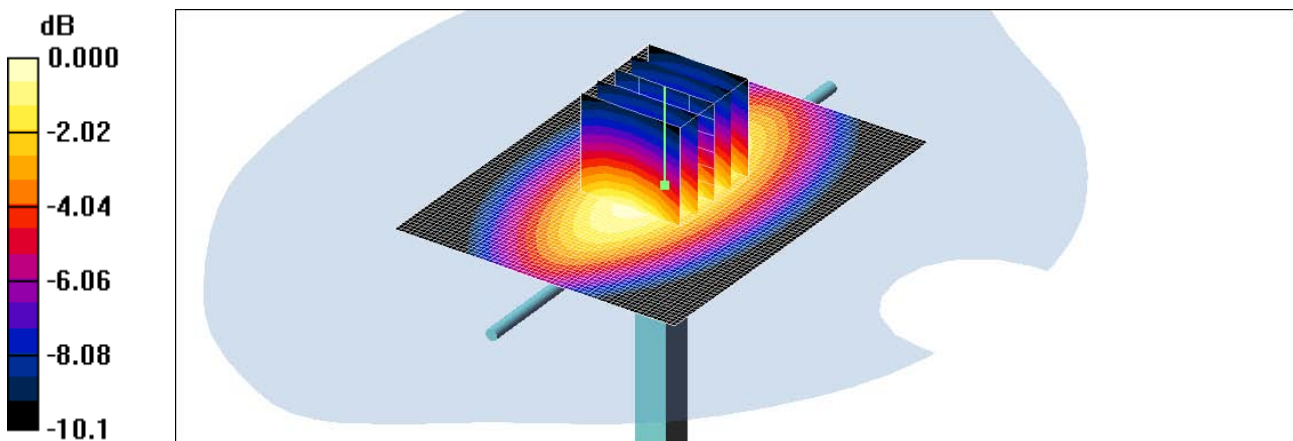

0 dB = 1.05mW/g

■ Validation Data (1900 MHz Head)

Test Laboratory: HCT CO., LTD
Input Power 100 mW (20 dBm)
Liquid Temp: 21.1 °C
Test Date: Nov.16, 2010

DUT: Dipole 1900 MHz; Type: D1900V2; Serial: D1900V2 – SN:5d032

Communication System: CW; Frequency: 1900 MHz; Duty Cycle: 1:1
Medium parameters used: $f = 1900$ MHz; $\sigma = 1.4$ mho/m; $\epsilon_r = 40.9$; $\rho = 1000$ kg/m³
Phantom section: Flat Section ; Measurement SW: DASY4, V4.7 Build 80; Postprocessing SW: SEMCAD, V1.8 Build 184

DASY4 Configuration:

- Probe: ES3DV3 – SN3161; ConvF(4.79, 4.79, 4.79); Calibrated: 2010-03-22
- Sensor-Surface: 4mm (Mechanical Surface Detection)
- Electronics: DAE3 Sn446; Calibrated: 2010-09-21
- Phantom: SAM 1800/1900 MHz; Type: SAM

Dipole 1900MHz Validation/Area Scan (61x61x1): Measurement grid: dx=15mm, dy=15mm
Maximum value of SAR (interpolated) = 4.58 mW/g

Dipole 1900MHz Validation/Zoom Scan (5x5x7)/Cube 0: Measurement grid: dx=8mm, dy=8mm, dz=5mm
Reference Value = 57.8 V/m; Power Drift = 0.009 dB
Peak SAR (extrapolated) = 7.18 W/kg
SAR(1 g) = 4.07 mW/g; SAR(10 g) = 2.22 mW/g
Maximum value of SAR (measured) = 4.39 mW/g

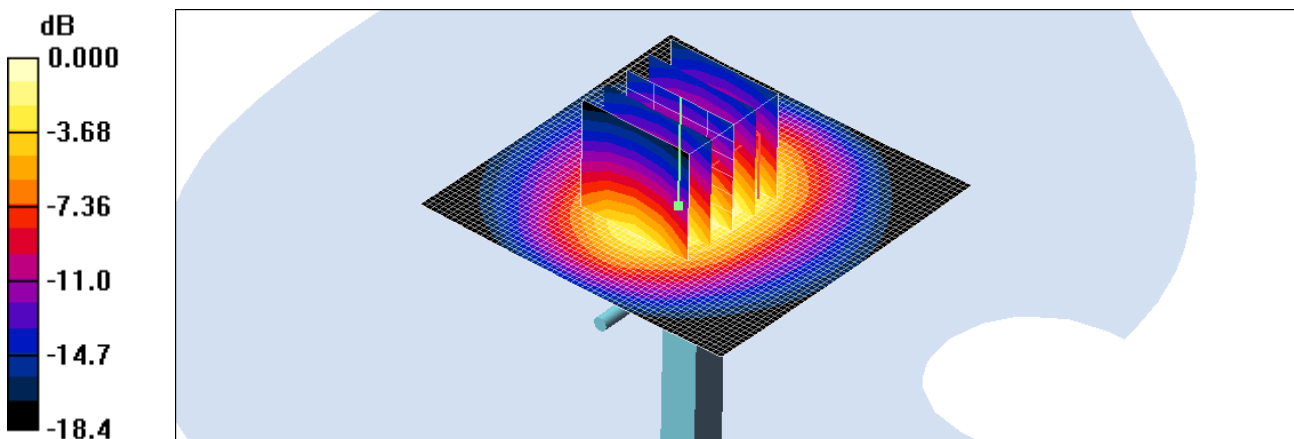

0 dB = 4.39mW/g

Validation Data (2450 MHz body)

Test Laboratory: HCT CO., LTD
 Input Power 100 mW (20 dBm)
 Liquid Temp: 21.1 °C
 Test Date: Nov.16, 2010

DUT: Dipole 2450 MHz; Type: D2450V2; Serial: D2450V2 – SN:743

Communication System: CW; Frequency: 2450 MHz; Duty Cycle: 1:1
 Medium parameters used: $f = 2450 \text{ MHz}$; $\sigma = 1.97 \text{ mho/m}$; $\epsilon_r = 51.7$; $\rho = 1000 \text{ kg/m}^3$
 Phantom section: Flat Section ; Measurement SW: DASY4, V4.7 Build 71; Postprocessing SW: SEMCAD, V1.8 Build 184

DASY4 Configuration:
 - Probe: ES3DV3 – SN3161; ConvF(4.17, 4.17, 4.17); Calibrated: 2010-03-22
 - Sensor-Surface: 4mm (Mechanical Surface Detection)
 - Electronics: DAE3 Sn446; Calibrated: 2010-09-21
 - Phantom: SAM 1800/1900 MHz; Type: SAM

Validation 2450MHz/Area Scan (61x61x1): Measurement grid: dx=15mm, dy=15mm
 Maximum value of SAR (interpolated) = 6.59 mW/g

Validation 2450MHz/Zoom Scan (5x5x7)/Cube 0: Measurement grid: dx=8mm, dy=8mm, dz=5mm
 Reference Value = 54.7 V/m; Power Drift = -0.017 dB
 Peak SAR (extrapolated) = 14.2 W/kg
SAR(1 g) = 5.52 mW/g; SAR(10 g) = 2.44 mW/g
 Maximum value of SAR (measured) = 5.90 mW/g

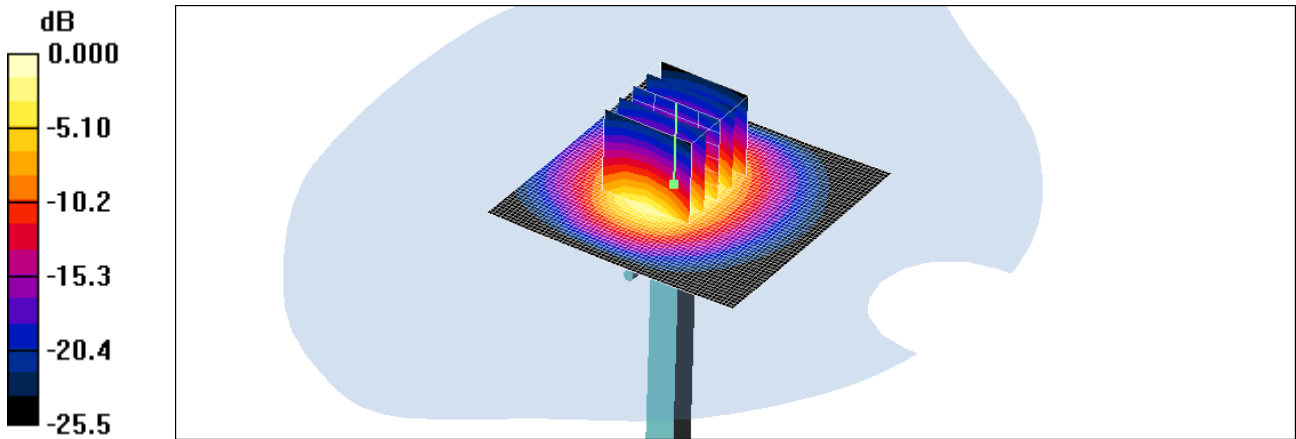

0 dB = 5.90mW/g

■ Validation Data (2450 MHz Head)

Test Laboratory: HCT CO., LTD
Input Power 100 mW (20 dBm)
Liquid Temp: 21.1 °C
Test Date: Dec. 7, 2010

DUT: Dipole 2450 MHz; Type: D2450V2; Serial: D2450V2 – SN:743

Communication System: CW; Frequency: 2450 MHz; Duty Cycle: 1:1
Medium parameters used: $f = 2450$ MHz; $\sigma = 1.88$ mho/m; $\epsilon_r = 38.2$; $\rho = 1000$ kg/m³
Phantom section: Flat Section ; Measurement SW: DASY4, V4.7 Build 80; Postprocessing SW: SEMCAD, V1.8 Build 184

DASY4 Configuration:

- Probe: ES3DV3 – SN3161; ConvF(4.26, 4.26, 4.26); Calibrated: 2010-03-22
- Sensor-Surface: 4mm (Mechanical Surface Detection)
- Electronics: DAE3 Sn446; Calibrated: 2010-09-21
- Phantom: SAM 1800/1900 MHz; Type: SAM

Validation 2450MHz/Area Scan (61x61x1): Measurement grid: dx=15mm, dy=15mm
Maximum value of SAR (interpolated) = 6.63 mW/g

Validation 2450MHz/Zoom Scan (5x5x7)/Cube 0: Measurement grid: dx=8mm, dy=8mm, dz=5mm
Reference Value = 57.0 V/m; Power Drift = 0.012 dB
Peak SAR (extrapolated) = 13.7 W/kg
SAR(1 g) = 5.55 mW/g; SAR(10 g) = 2.46 mW/g
Maximum value of SAR (measured) = 6.07 mW/g

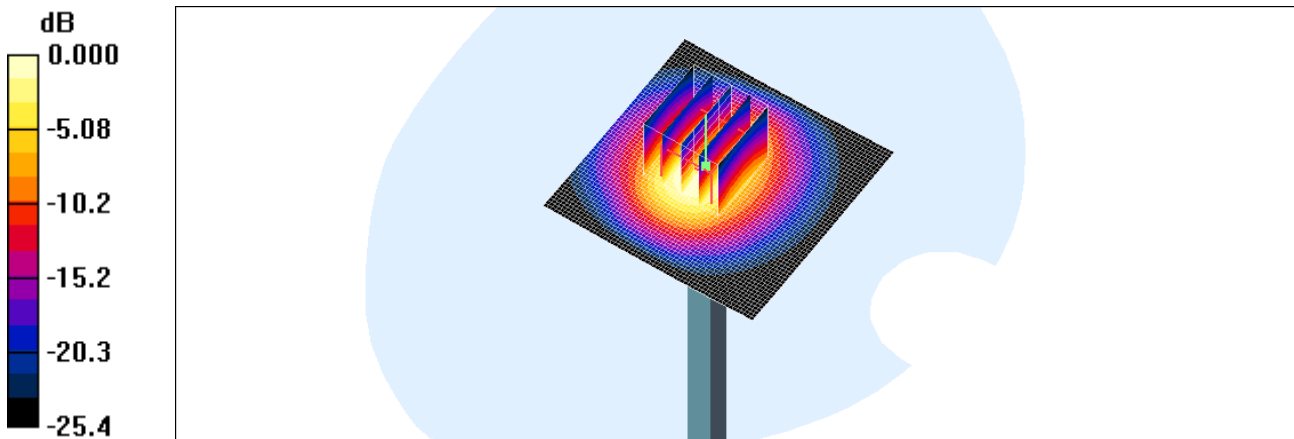

0 dB = 6.07mW/g

Validation Data (2450 MHz body)

Test Laboratory: HCT CO., LTD
 Input Power 100 mW (20 dBm)
 Liquid Temp: 21.1 °C
 Test Date: Nov.16, 2010

DUT: Dipole 2450 MHz; Type: D2450V2; Serial: D2450V2 – SN:743

Communication System: CW; Frequency: 2450 MHz; Duty Cycle: 1:1
 Medium parameters used: $f = 2450$ MHz; $\sigma = 1.97$ mho/m; $\epsilon_r = 51.7$; $\rho = 1000$ kg/m³
 Phantom section: Flat Section ; Measurement SW: DASY4, V4.7 Build 71; Postprocessing SW: SEMCAD, V1.8 Build 184

DASY4 Configuration:
 - Probe: ES3DV3 – SN3161; ConvF(4.17, 4.17, 4.17); Calibrated: 2010-03-22
 - Sensor-Surface: 4mm (Mechanical Surface Detection)
 - Electronics: DAE3 Sn446; Calibrated: 2010-09-21
 - Phantom: SAM 1800/1900 MHz; Type: SAM

Validation 2450MHz/Area Scan (61x61x1): Measurement grid: dx=15mm, dy=15mm
 Maximum value of SAR (interpolated) = 6.59 mW/g

Validation 2450MHz/Zoom Scan (5x5x7)/Cube 0: Measurement grid: dx=8mm, dy=8mm, dz=5mm
 Reference Value = 54.7 V/m; Power Drift = -0.017 dB
 Peak SAR (extrapolated) = 14.2 W/kg
SAR(1 g) = 5.52 mW/g; SAR(10 g) = 2.44 mW/g
 Maximum value of SAR (measured) = 5.90 mW/g

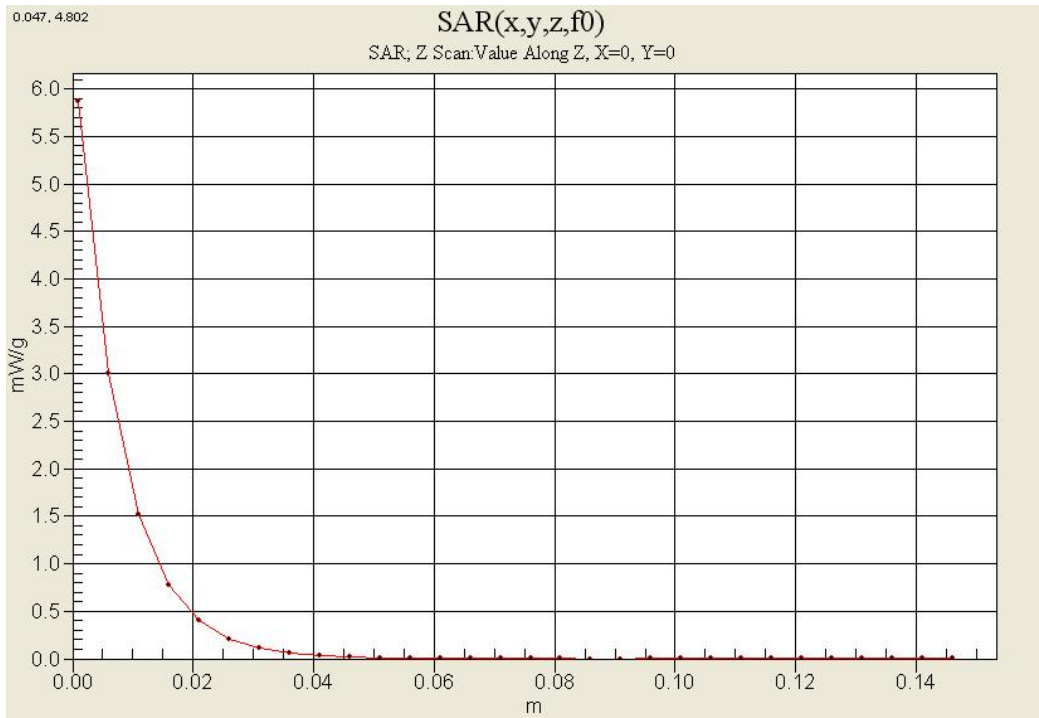

■ Dielectric Parameter (835 MHz Head)

Title P8000
SubTitle GSM850(Head)
Test Date Nov.15, 2010

Frequency	e'	e''
800000000.0000	42.5226	19.2549
805000000.0000	42.4448	19.2621
810000000.0000	42.3808	19.2171
815000000.0000	42.3497	19.1904
820000000.0000	42.3219	19.1736
825000000.0000	42.2159	19.2163
830000000.0000	42.1760	19.1873
835000000.0000	42.1341	19.1487
840000000.0000	42.1165	19.1193
845000000.0000	42.0491	19.1513
850000000.0000	42.0020	19.1410
855000000.0000	41.9686	19.1218
860000000.0000	41.8953	19.1042
865000000.0000	41.8371	19.0825
870000000.0000	41.7446	19.0966
875000000.0000	41.6953	19.0983
880000000.0000	41.6151	19.0436
885000000.0000	41.5948	19.0522
890000000.0000	41.5255	19.0454
895000000.0000	41.4335	19.0257
900000000.0000	41.3973	19.0393

■ Dielectric Parameter (835 MHz Body)

Title P8000
 SubTitle GSM850(Body)
 Test Date Nov.15, 2010

Frequency	e'	e''
800000000.0000	57.0284	21.3302
805000000.0000	57.0326	21.2815
810000000.0000	56.9893	21.3140
815000000.0000	56.9207	21.2542
820000000.0000	56.9556	21.2305
825000000.0000	56.9345	21.2281
830000000.0000	56.8828	21.1925
835000000.0000	56.8967	21.1255
840000000.0000	56.7984	21.1078
845000000.0000	56.7729	21.0319
850000000.0000	56.6993	21.0287
855000000.0000	56.6750	21.0070
860000000.0000	56.5758	20.9301
865000000.0000	56.4983	20.9353
870000000.0000	56.4038	20.8622
875000000.0000	56.3602	20.8138
880000000.0000	56.2926	20.8284
885000000.0000	56.2392	20.8044
890000000.0000	56.1576	20.8193
895000000.0000	56.0598	20.7744
900000000.0000	56.0646	20.7828

■ Dielectric Parameter (1900 MHz Head)

Title P8000
SubTitle WCDMA1900(Head)
Test Date Nov.16, 2010

Frequency	e'	e''
1800000000.0000	41.3173	12.9505
1810000000.0000	41.3068	12.9948
1820000000.0000	41.2803	13.0552
1830000000.0000	41.2672	13.1007
1840000000.0000	41.2399	13.1552
1850000000.0000	41.1946	13.1938
1860000000.0000	41.1255	13.1658
1870000000.0000	41.0878	13.2211
1880000000.0000	41.0128	13.2040
1890000000.0000	40.9536	13.2133
1900000000.0000	40.8737	13.2217
1910000000.0000	40.8304	13.2152
1920000000.0000	40.7840	13.2562
1930000000.0000	40.7861	13.3004
1940000000.0000	40.7468	13.3127
1950000000.0000	40.7633	13.3349
1960000000.0000	40.7958	13.3876
1970000000.0000	40.7952	13.4208
1980000000.0000	40.7573	13.4500
1990000000.0000	40.6949	13.5321
2000000000.0000	40.6595	13.5271

■ Dielectric Parameter (1900 MHz Body)

Title P8000
SubTitle WCDMA1900(Body)
Test Date Nov.16, 2010

Frequency	e'	e''
1850000000.0000	53.8651	14.0048
1855000000.0000	53.8672	14.0044
1860000000.0000	53.8556	14.0329
1865000000.0000	53.8615	14.0477
1870000000.0000	53.8374	14.0422
1875000000.0000	53.7727	14.0697
1880000000.0000	53.7401	14.0986
1885000000.0000	53.6886	14.0822
1890000000.0000	53.6154	14.0999
1895000000.0000	53.5627	14.1198
1900000000.0000	53.5340	14.1117
1905000000.0000	53.4861	14.1420
1910000000.0000	53.4362	14.1678
1915000000.0000	53.4032	14.2095
1920000000.0000	53.3826	14.2534
1925000000.0000	53.3761	14.2549
1930000000.0000	53.3427	14.2949
1935000000.0000	53.3766	14.3344
1940000000.0000	53.3743	14.3558
1945000000.0000	53.3908	14.4151
1950000000.0000	53.4241	14.3887

■ Dielectric Parameter (2450 MHz Head)

Title P8000
SubTitle WCDMA1900(Body)
Test Date Dec. 7, 2010

Frequency	e'	e''
2400000000.0000	38.7000	13.7427
2405000000.0000	38.6544	13.7016
2410000000.0000	38.6460	13.6457
2415000000.0000	38.5391	13.5841
2420000000.0000	38.4990	13.6133
2425000000.0000	38.4553	13.5712
2430000000.0000	38.3983	13.5642
2435000000.0000	38.3297	13.5753
2440000000.0000	38.2932	13.6476
2445000000.0000	38.2697	13.6480
2450000000.0000	38.2303	13.7744
2455000000.0000	38.2178	13.8489
2460000000.0000	38.2059	13.9463
2465000000.0000	38.2494	14.0316
2470000000.0000	38.2344	14.1193
2475000000.0000	38.2369	14.1609
2480000000.0000	38.2887	14.2217
2485000000.0000	38.2877	14.2508
2490000000.0000	38.3580	14.2908
2495000000.0000	38.3563	14.2643
2500000000.0000	38.3715	14.2366

■ Dielectric Parameter (2450 MHz Body)

Title P8000
 SubTitle WCDMA1900(Body)
 Test Date Nov.16, 2010

Frequency	e'	e''
2400000000.0000	52.0310	14.1128
2405000000.0000	52.0354	14.1254
2410000000.0000	51.9941	14.1131
2415000000.0000	51.9858	14.0969
2420000000.0000	51.9916	14.0857
2425000000.0000	51.9542	14.1591
2430000000.0000	51.8058	14.2899
2435000000.0000	51.7593	14.3523
2440000000.0000	51.7437	14.3764
2445000000.0000	51.7059	14.4063
2450000000.0000	51.7146	14.4340
2455000000.0000	51.7110	14.4399
2460000000.0000	51.7095	14.4619
2465000000.0000	51.6867	14.4964
2470000000.0000	51.6718	14.5132
2475000000.0000	51.6629	14.5225
2480000000.0000	51.6990	14.5724
2485000000.0000	51.6724	14.5558
2490000000.0000	51.6643	14.5910
2495000000.0000	51.6638	14.5824
2500000000.0000	51.6474	14.6136

Validation Data (835 MHz Body)

Test Laboratory: HCT CO., LTD
 Input Power 100 mW (20 dBm)
 Liquid Temp: 21.2 °C
 Test Date: Mar.20, 2011

DUT: Dipole 835 MHz; Type: D835V2; Serial: D835V2 – SN:441

Communication System: CW; Frequency: 835 MHz; Duty Cycle: 1:1
 Medium parameters used: $f = 835 \text{ MHz}$; $\sigma = 0.98 \text{ mho/m}$; $\epsilon_r = 56.9$; $\rho = 1000 \text{ kg/m}^3$
 Phantom section: Flat Section ; Measurement SW: DASY4, V4.7 Build 80; Postprocessing SW: SEMCAD, V1.8 Build 184

DASY4 Configuration:
 - Probe: ET3DV6 – SN1630; ConvF(6.17, 6.17, 6.17); Calibrated: 2010-05-25
 - Sensor-Surface: 4mm (Mechanical Surface Detection)
 - Electronics: DAE4 Sn869; Calibrated: 2010-09-21
 - Phantom: SAM 1800/1900 MHz; Type: SAM

Validation 835MHz/Area Scan (61x61x1): Measurement grid: dx=15mm, dy=15mm
 Maximum value of SAR (interpolated) = 1.09 mW/g

Validation 835MHz/Zoom Scan (5x5x7)/Cube 0: Measurement grid: dx=8mm, dy=8mm, dz=5mm
 Reference Value = 34.4 V/m; Power Drift = -0.025 dB
 Peak SAR (extrapolated) = 1.48 W/kg
SAR(1 g) = 1.000 mW/g; SAR(10 g) = 0.644 mW/g
 Maximum value of SAR (measured) = 1.09 mW/g

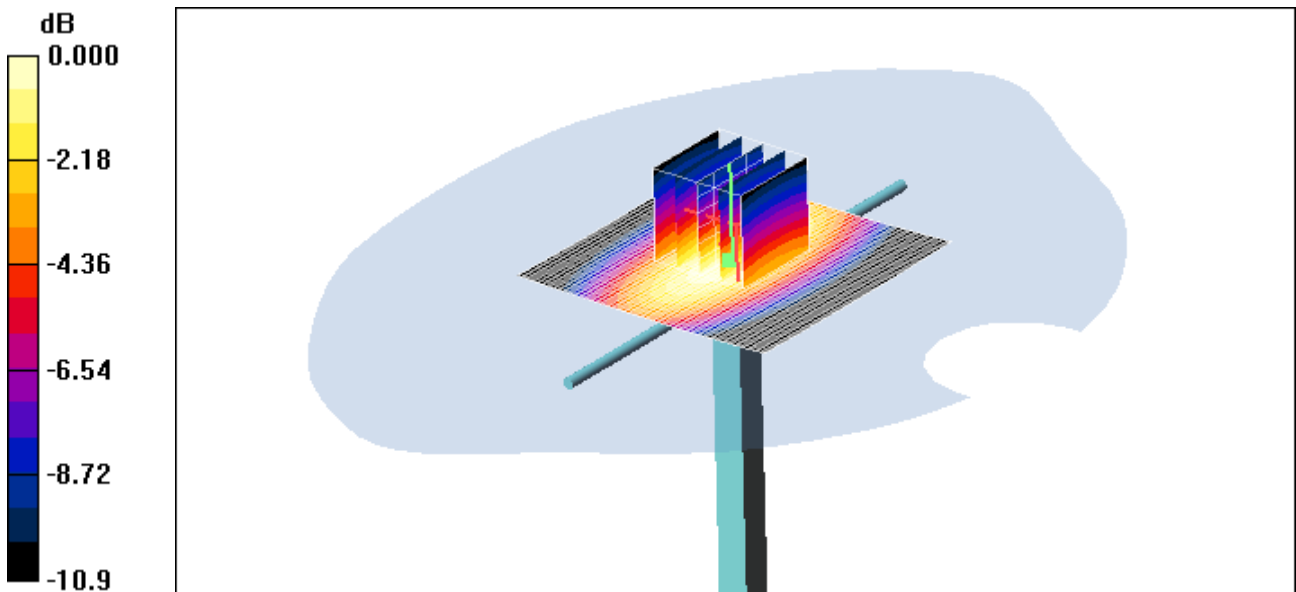

0 dB = 1.09mW/g

Validation Data (1900 MHz Body)

Test Laboratory: HCT CO., LTD
 Input Power 100 mW (20 dBm)
 Liquid Temp: 21.3 °C
 Test Date: Mar.21, 2011

DUT: Dipole 1900 MHz; Type: D1900V2; Serial: D1900V2 – SN:5d032

Communication System: CW; Frequency: 1900 MHz; Duty Cycle: 1:1
 Medium parameters used: $f = 1900 \text{ MHz}$; $\sigma = 1.58 \text{ mho/m}$; $\epsilon_r = 53.3$; $\rho = 1000 \text{ kg/m}^3$
 Phantom section: Flat Section ; Measurement SW: DASY4, V4.7 Build 80; Postprocessing SW: SEMCAD, V1.8 Build 184

DASY4 Configuration:
 - Probe: ET3DV6 – SN1630; ConvF(4.55, 4.55, 4.55); Calibrated: 2010-05-25
 - Sensor-Surface: 4mm (Mechanical Surface Detection)
 - Electronics: DAE4 Sn869; Calibrated: 2010-09-21
 - Phantom: SAM 1800/1900 MHz; Type: SAM

Dipole 1900MHz Validation/Area Scan (61x61x1): Measurement grid: dx=15mm, dy=15mm
 Maximum value of SAR (interpolated) = 5.01 mW/g

Dipole 1900MHz Validation/Zoom Scan (5x5x7)/Cube 0: Measurement grid: dx=8mm, dy=8mm, dz=5mm
 Reference Value = 58.9 V/m; Power Drift = -0.014 dB
 Peak SAR (extrapolated) = 6.85 W/kg
SAR(1 g) = 4.28 mW/g; SAR(10 g) = 2.25 mW/g
 Maximum value of SAR (measured) = 4.87 mW/g

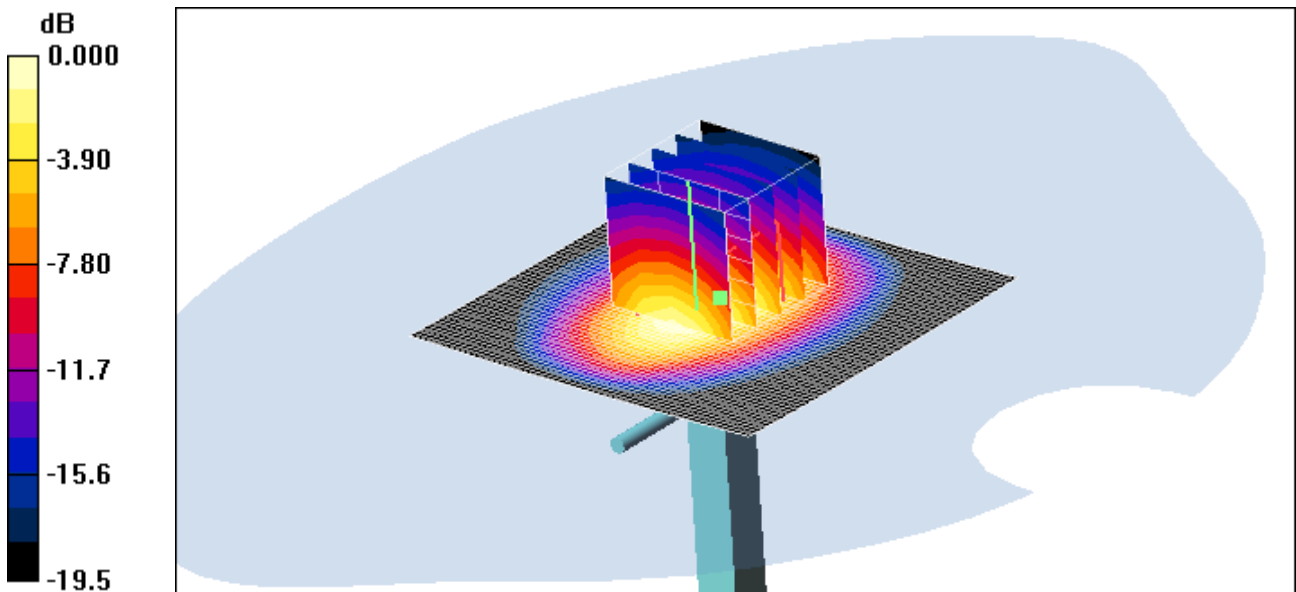

0 dB = 4.87mW/g

■ Validation Data (2450 MHz Body)

Test Laboratory: HCT CO., LTD
Input Power 100 mW (20 dBm)
Liquid Temp: 21.3 °C
Test Date: Mar.21, 2011

DUT: Dipole 2450 MHz; Type: D2450V2; Serial: D2450V2 – SN:743

Communication System: CW; Frequency: 2450 MHz; Duty Cycle: 1:1
Medium parameters used: $f = 2450$ MHz; $\sigma = 1.96$ mho/m; $\epsilon_r = 51.6$; $\rho = 1000$ kg/m³
Phantom section: Flat Section ; Measurement SW: DASY4, V4.7 Build 80; Postprocessing SW: SEMCAD, V1.8 Build 184

DASY4 Configuration:

- Probe: ET3DV6 – SN1630; ConvF(4.15, 4.15, 4.15); Calibrated: 2010-05-25
- Sensor-Surface: 4mm (Mechanical Surface Detection)
- Electronics: DAE4 Sn869; Calibrated: 2010-09-21
- Phantom: SAM 1800/1900 MHz; Type: SAM

Validation 2450MHz/Area Scan (61x61x1): Measurement grid: dx=15mm, dy=15mm
Maximum value of SAR (interpolated) = 6.44 mW/g

Validation 2450MHz/Zoom Scan (5x5x7)/Cube 0: Measurement grid: dx=8mm, dy=8mm, dz=5mm
Reference Value = 55.8 V/m; Power Drift = 0.004 dB
Peak SAR (extrapolated) = 13.0 W/kg
SAR(1 g) = 5.38 mW/g; SAR(10 g) = 2.39 mW/g
Maximum value of SAR (measured) = 5.93 mW/g

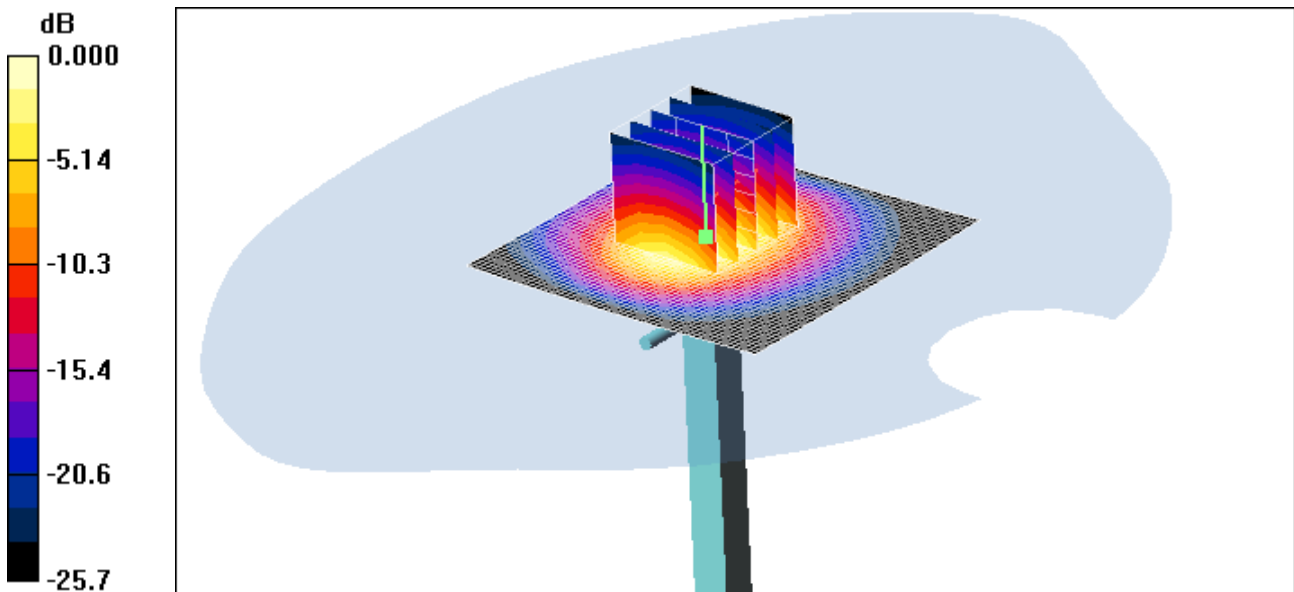

0 dB = 5.93mW/g

■ Dielectric Parameter (835 MHz Body)

Title P8000
SubTitle GSM850(Body)
Test Date Mar.20, 2011

Frequency	e'	e''
800000000.0000	57.0420	21.2859
805000000.0000	56.9841	21.2428
810000000.0000	56.9832	21.2342
815000000.0000	56.9196	21.2181
820000000.0000	56.9277	21.1542
825000000.0000	56.8925	21.1599
830000000.0000	56.8687	21.1093
835000000.0000	56.8567	21.1024
840000000.0000	56.7938	21.0832
845000000.0000	56.7209	21.0116
850000000.0000	56.7228	20.9749
855000000.0000	56.6181	20.9856
860000000.0000	56.5499	20.9002
865000000.0000	56.4590	20.9133
870000000.0000	56.3504	20.8309
875000000.0000	56.3136	20.7790
880000000.0000	56.2349	20.8047
885000000.0000	56.1830	20.7757
890000000.0000	56.1151	20.7917
895000000.0000	56.0960	20.7618
900000000.0000	56.0866	20.7611