



HCT CO., LTD.

Product Compliance Division

TEL : +82 31 639 8518 FAX : +82 31 639 8525

CERTIFICATE OF COMPLIANCE

FCC Part 24 & 22 Certification

Applicant Name:

Pantech Co., Ltd.

Date of Issue:

March 25, 2009

Test Site/Location:

HCT.CO., LTD., San 136-1 Ami-ri, Bubal-eup, Icheon-si, Kyoungki-do, Korea

Address:

PANTECH Building, I-2, DMC, Sangam-dong, Mapo-gu, Seoul, 121-792, Korea

Test Report No.: HCT-RF09-0313

HCT FRN: 0005866421

FCC ID : JYCC790

APPLICANT : Pantech Co., Ltd.

Application Type:

Certification

FCC Classification:

Licensed Portable Transmitter Held to Ear (PCE)

FCC Rule Part(s):

§22, §24, §2

EUT Type:

Dual-Band Dual-Mode GSM/WCDMA Phone with Bluetooth

Model(s):

C790

Tx Frequency:

824.20 - 848.80 MHz (GSM850)
826.4~846.6 MHz (WCDMA850)
1 850.20 - 1 909.80 MHz (GSM1900)
1 852.4 - 1 907.6 MHz (WCDMA1900)

Rx Frequency:

869.20 - 893.80 MHz (GSM850)
871.4 - 891.6 (WCDMA850)
1 930.20 - 1 989.80 MHz (GSM1900)
1 932.4 - 1 987.6 MHz (WCDMA1900)

Max. RF Output Power:

1.432 W ERP GSM850 (31.56 dBm) / 0.718 W EIRP GSM1900 (28.56 dBm)
0.733 W ERP EDGE850 (28.65 dBm) / 0.604 W EIRP EDGE1900 (27.81 dBm)
0.364 W ERP WCDMA850(25.61 dBm) / 0.441 W EIRP WCDMA1900(26.44 dBm)

Emission Designator(s):

248KGXW (GSM850) 249KGXW (GSM1900)
247KG7W (GSM850 EDGE) 244G7W (GSM1900 EDGE)
4M18F9W (WCDMA850) 4M18F9W (WCDMA1900)

The measurements shown in this report were made in accordance with the procedures specified in §2.947. I assume full responsibility for the accuracy and completeness of these measurements, and for the qualifications of all persons taking them.

HCT.CO., LTD. Certifies that no party to this application has been denied FCC benefits pursuant to section 5301 of the Anti-Drug Abuse Act of 1998,21 U.S. C.853(a)

Report prepared by

: Jong Seok Lee

Test engineer of RF Part

Approved by

: Sang Jun Lee

Manager of RF Part

This report only responds to the tested sample and may not be reproduced, except in full, without written approval of the HCT Co., Ltd.

FCC CERTIFICATION REPORT				www.hct.co.kr
Test Report No. HCT-RF09-0313	Date of Issue: March 25, 2009	EUT Type: Dual-Band Dual-Mode GSM/WCDMA Phone with Bluetooth	FCC ID: JYCC790	Page 1 of 53



Table of Contents

1. GENERAL INFORMATION	3
2. INTRODUCTION.....	4
2.1. EUT DESCRIPTION.....	4
2.2. MEASURING INSTRUMENT CALIBRATION	4
2.3. TEST FACILITY	4
3. DESCRIPTION OF TESTS.....	5
3.1 Effective Radiated Power/Equivalent Isotropic Radiated Power.....	5
3.2 Peak- to- Average Ratio	6
3.3 Occupied bandwidth.....	6
3.4 Spurious and Harmonic Emissions at Antenna Terminal.....	7
3.5 Radiated Spurious and Harmonic Emissions	8
3.6 Frequency stability / variation of ambient temperature.....	9
4. LIST OF TEST EQUIPMENT	10
5. SUMMARY OF TEST RESULTS	11
6. SAMPLE CALCULATION.....	12
7. TEST DATA	13
7.1 Conducted Output Power.....	13
7.2 Peak-to-Average Ratio	14
7.3 Effective Radiated Power Output (GSM / WCDMA)	15
7.4 Equivalent Isotropic Radiated Power (E.I.R.P.) (GSM).....	16
7.5 Radiated Spurious Emissions	17
7.5.1 Radiated Spurious Emissions (GSM850).....	17
7.5.2 Radiated Spurious Emissions (GSM1900).....	18
7.5.3 Radiated Spurious Emissions (WCDMA850).....	19
7.5.4 Radiated Spurious Emissions (WCDMA1900).....	20
7.6 Frequency stability / variation of ambient temperature.....	21
7.6.1 FREQUENCY STABILITY (GSM850)	21
7.6.2 FREQUENCY STABILITY (GSM1900)	22
7.6.3 FREQUENCY STABILITY (WCDMA850).....	23
7.6.4 FREQUENCY STABILITY (WCDMA1900).....	24
8. TEST PLOTS.....	25



MEASUREMENT REPORT

1. GENERAL INFORMATION

Applicant Name: Pantech Co., Ltd.

Address: PANTECH Building, I-2, DMC, Sangam-dong, Mapo-gu, Seoul, 121-792, Korea

FCC ID: JYCC790

Application Type: Certification

FCC Classification: Licensed Portable Transmitter Held to Ear (PCE)

FCC Rule Part(s): §22, §24, §2

EUT Type: Dual-Band Dual-Mode GSM/WCDMA Phone with Bluetooth

Model(s): C790

Tx Frequency: 824.20 - 848.80 MHz (GSM850)
826.4~846.6 MHz (WCDMA850)
1 850.20 – 1 909.80 MHz (GSM1900)
1 852.4 – 1 907.6 MHz (WCDMA1900)

Rx Frequency: 869.20 - 893.80 MHz (GSM850)
871.4 - 891.6 (WCDMA850)
1 930.20 – 1 989.80 MHz (GSM1900)
1 932.4 – 1 987.6 MHz (WCDMA1900)

Max. RF Output Power: 1.432 W ERP GSM850 (31.56 dBm) / 0.718 W EIRP GSM1900 (28.56 dBm)
0.733 W ERP EDGE850 (28.65 dBm) / 0.604 W EIRP EDGE1900 (27.81 dBm)
0.364 W EIRP WCDMA850(25.61 dBm) / 0.441 W EIRP WCDMA1900(26.44 dBm)

Emission Designator(s): 248KGXW (GSM850) 249KGXW (GSM1900)
247KG7W (GSM850 EDGE) 244G7W (GSM1900 EDGE)
4M18F9W (WCDMA850) 4M18F9W (WCDMA1900)

Antenna Specification Manufacturer: ACE ANTENNA
Antenna type: Internal Antenna
Peak Gain : -2.57 dBi

Date(s) of Tests: March 04, 2009 ~ March 20, 2009

Place of Tests: HCT.CO., LTD.
San 136-1 Ami-ri, Bubal-eup, Icheon-si,

Report Serial No HCT-RF09-0313

FCC CERTIFICATION REPORT				www.hct.co.kr
Test Report No. HCT-RF09-0313	Date of Issue: March 25, 2009	EUT Type: Dual-Band Dual-Mode GSM/WCDMA Phone with Bluetooth	FCC ID: JYCC790	Page 3 of 53



2. INTRODUCTION

2.1. EUT DESCRIPTION

The Pantech Co., Ltd. C790 Dual-Band Dual-Mode GSM/WCDMA Phone with Bluetooth consists of GSM850, GSM1900, GPRS Class12, EDGE and WCDMA850, WCDMA1900, HSDPA.

2.2. MEASURING INSTRUMENT CALIBRATION

The measuring equipment, which was utilized in performing the tests documented herein, has been calibrated in accordance with the manufacturer's recommendations for utilizing calibration equipment, which is traceable to recognized national standards.

2.3. TEST FACILITY

The open area test site and conducted measurement facility used to collect the radiated data are located at the 254-1, Maekok-Ri, Hobup-Myun, Ichon-Si, Kyoungki-Do, 467-701, KOREA. The site is constructed in conformance with the requirements of ANSI C63.4 and CISPR Publication 22. Detailed description of test facility was submitted to the Commission and accepted dated July 6, 2006(Registration Number: 90661)

FCC CERTIFICATION REPORT				www.hct.co.kr
Test Report No. HCT-RF09-0313	Date of Issue: March 25, 2009	EUT Type: Dual-Band Dual-Mode GSM/WCDMA Phone with Bluetooth	FCC ID: JYCC790	Page 4 of 53

3. DESCRIPTION OF TESTS

3.1 Effective Radiated Power/Equivalent Isotropic Radiated Power

Test Set-up

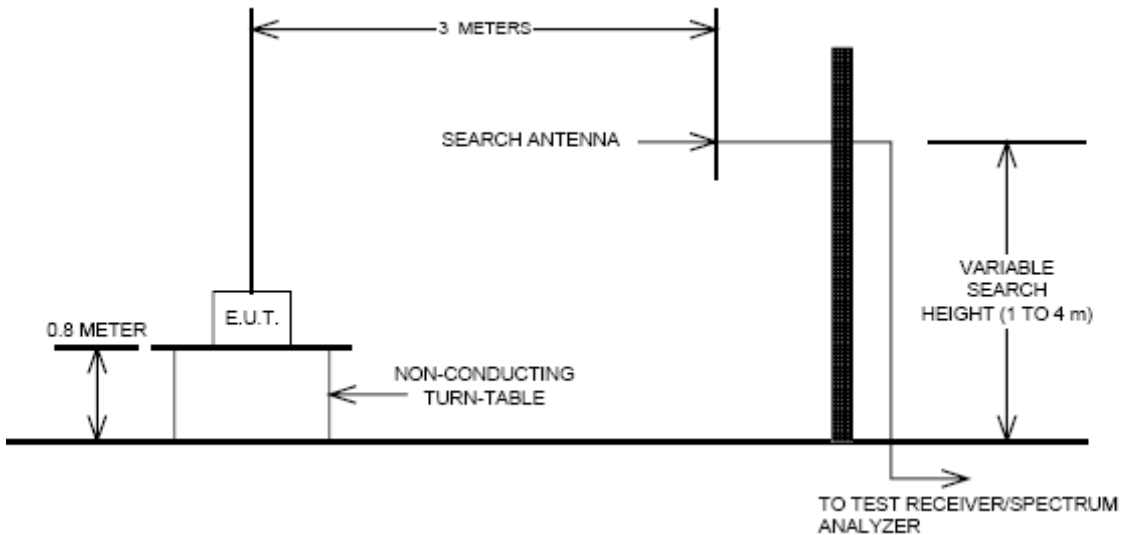

Test Procedure

Radiated emission measurements were performed at an open Site.

The equipment under test is placed on a wooden turntable 3-meters from the receive antenna.

A wooden turntable was rotated 360° and the receiving antenna scanned from 1-4m in order to capture the maximum emission. A half wave dipole was substituted in place of the EUT. This dipole antenna was driven by a signal generator and the previously recorded signal was duplicated.

The maximum EIRP was calculated by adding the forward power to the calibrated source plus its appropriate gain value. These steps were carried out with the receiving antenna in both vertical and horizontal polarization. For readings above 1GHz, the above procedure is repeated using horn antennas and the difference between the gain of the horn and an isotropic antenna are taken into consideration.

3.2 Peak- to- Average Ratio

A peak to average ratio measurement is performed at the conducted port of the EUT. For CDMA and WCDMA signals, the spectrum analyzers Complementary Cumulative Distribution Function (CCDF) measurement profile is used to determine the largest deviation between the average and the peak power of the EUT in a given bandwidth. The CCDF curve shows how much time the peak waveform spends at or above a given average power level. The percent of time the signal spends at or above the level defines the probability for that particular power level. For GSM signals, an average and a peak trace are used on a spectrum analyzer to determine the largest deviation between the average and the peak power of the EUT in a bandwidth greater than the emission bandwidth. Plots of the EUT’s Peak- to- Average Ratio are shown herein.

3.3 Occupied bandwidth.

Test set-up

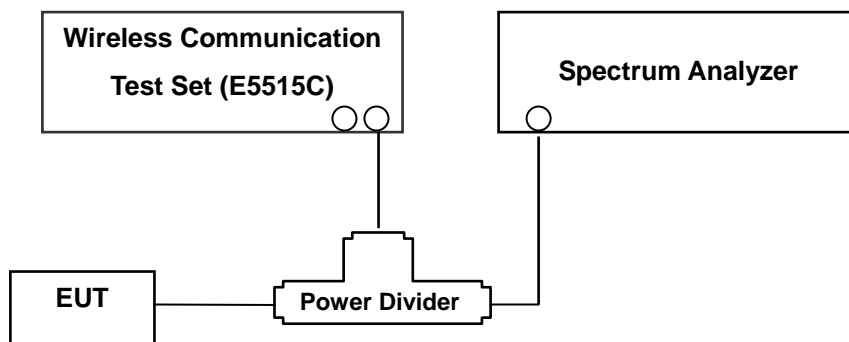

(Configuration of conducted Emission measurement)
Test Procedure

The EUT was setup to maximum output power at its lowest channel. The occupied bandwidth was measured using a spectrum analyzer. The measurements are repeated for the highest and a middle channel. The EUT’s occupied bandwidth is measured as the width of the signal between two points, one below the carrier center frequency and one above the carrier frequency, outside of which all emissions are attenuated at least 26 dB below the transmitter power. Plots of the EUT’s occupied bandwidth are shown herein.



3.4 Spurious and Harmonic Emissions at Antenna Terminal.

Test Procedure

The level of the carrier and the various conducted spurious and harmonic frequencies is measured by means of a calibrated spectrum analyzer.

The EUT was setup to maximum output power at its lowest channel. The Resolution BW of the analyzer is set to 1 % of the emission bandwidth to show compliance with the – 13 dBm limit, in the 1 MHz bands immediately outside and adjacent to the edge of the frequency block. The 1 MHz RBW was used to scan from 10 MHz to 10 GHz. (GSM1900 Mode: 10 MHz to 20 GHz). A display line was placed at – 13 dBm to show compliance. The high, lowest and a middle channel were tested for out of band measurements.

- Band Edge Requirement : In the 1MHz bands immediately outside and adjacent to the frequency block, a resolution bandwidth of at least 1 percent of the emission bandwidth of the fundamental emission of the transmitter may be employed to measure the out of band Emissions. Limit, -13dBm.

FCC CERTIFICATION REPORT				www.hct.co.kr
Test Report No. HCT-RF09-0313	Date of Issue: March 25, 2009	EUT Type: Dual-Band Dual-Mode GSM/WCDMA Phone with Bluetooth	FCC ID: JYCC790	Page 7 of 53

3.5 Radiated Spurious and Harmonic Emissions

Test Set-up

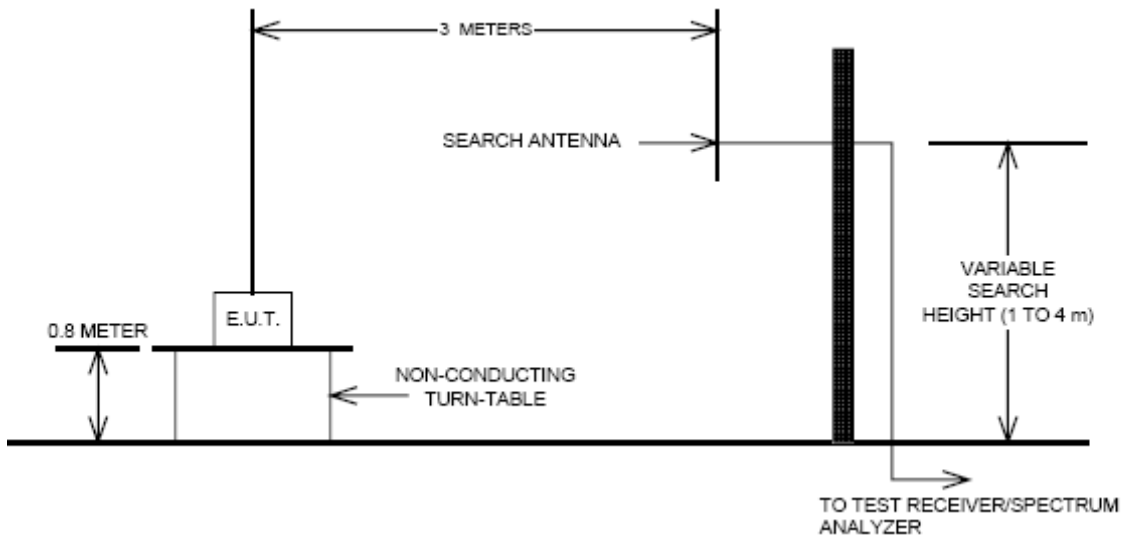

The measurement facilities used for this test have been documented in previous filings with the commission pursuant to section § 2.948. The open field test site is situated in open field with ground screen whose site attenuation characteristics meet ANSI C63.4 –2003. A mast capable of lifting the receiving antenna from a height of one to four meters is used together with a rotatable wooden platform mounted at three from the antenna mast.

- 1) The unit mounted on a wooden table 1.5 m × 1.0 m × 0.80 m is 0.8 meter above test site ground level.
- 2) During the emission test, the turntable is rotated and the EUT is manipulated to find the configuration resulting in maximum emission under normal condition of installation and operation.
- 3) The antenna height and polarization are also varied from 1 to 4 meters until the maximum signal is found.
- 4) The spectrum shall be scanned up to the 10th harmonic of the fundamental frequency.

Test Procedure

The equipment under test is placed on a wooden turntable 3-meters from the receive antenna. A wooden turntable was rotated 360° and the receiving antenna scanned from 1-4m in order to capture the maximum emission. A half wave dipole was substituted in place of the EUT. This dipole antenna was driven by a signal generator and the previously recorded signal was duplicated.

The maximum EIRP was calculated by adding the forward power to the calibrated source plus its appropriate gain value. These steps were carried out with the receiving antenna in both vertical and horizontal polarization. For readings above 1GHz, the above procedure is repeated using horn antennas and the difference between the gain of the horn and an isotropic antenna are taken into consideration.

3.6 Frequency stability / variation of ambient temperature

Test Set-up

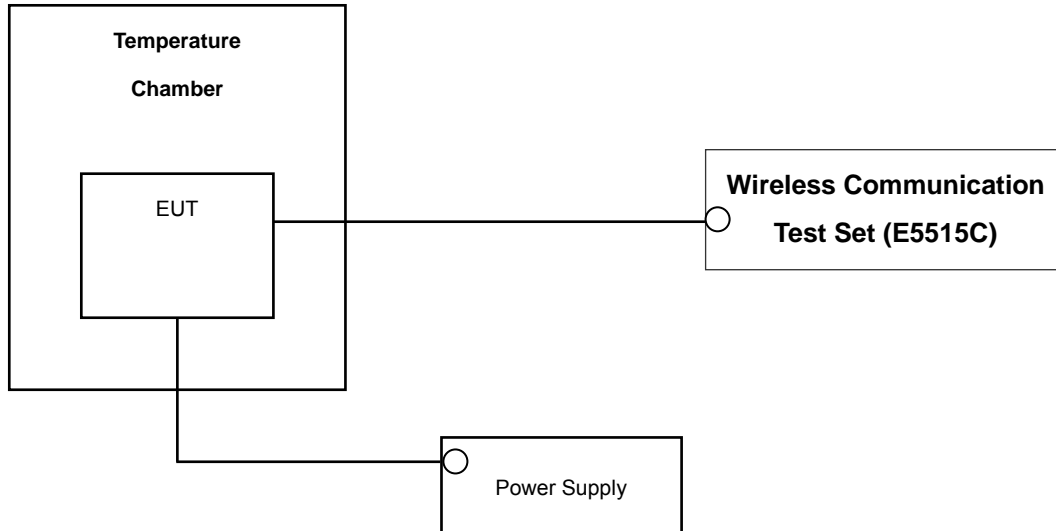

* Nominal Operating Voltage

Test Procedure

The frequency stability of the transmitter is measured by:

- a.) **Temperature:** The temperature is varied from - 30 °C to + 50 °C using an environmental chamber.
- b.) **Primary Supply Voltage:** The primary supply voltage is varied from battery end point to 115 % of the voltage normally at the input to the device or at the power supply terminals if cables are not normally supplied.

Specification — the frequency stability shall be sufficient to ensure that the fundamental emission stays within the authorized frequency block. The frequency stability of the transmitter shall be maintained within $\pm 0.00025\%$ (± 2.5 ppm) of the center frequency.

Time Period and Procedure:

The carrier frequency of the transmitter is measured at room temperature (20°C to provide a reference).

1. The equipment is turned on in a “standby” condition for one minute before applying power to the transmitter. Measurement of the carrier frequency of the transmitter is made within one minute after applying power to the transmitter.
2. Frequency measurements are made at 10°C intervals ranging from -30°C to +50°C. A period of at least one half-hour is provided to allow stabilization of the equipment at each temperature level.

NOTE: The EUT is tested down to the battery endpoint.



4. LIST OF TEST EQUIPMENT

Manufacture	Model/ Equipment	Serial Number	Calibration Interval	Calibration Due
R&S	ESI40/ Spectrum Analyzer	831564/003	Annual	10/31/2009
Agilent	E4416A/ Power Meter	GB41291412	Annual	01/21/2010
Agilent	E9327A/ Power Sensor	MY4442009	Annual	07/28/2009
Agilent	8960 (E5515C)/ Base Station	GB44400269	Annual	02/10/2010
MITEQ	AMF-60-0010 1800-35-20P / AMP	1200937	Annual	05/20/2009
Wainwright	WHK1.2/15G-10EF/H.P.F	2	Annual	06/28/2009
Wainwright	WHK3.3/18G-10EF/H.P.F	1	Annual	06/28/2009
Agilent	775D/ Dual Directional Coupler	12922	Annual	12/24/2009
Agilent	11636B/ Power Divider	11377	Annual	12/24/2009
Digital	EP-3010/ Power Supply	3110117	Annual	01/07/2010
Schwarzbeck	UHAP/ Dipole Antenna	585	Annual	02/13/2011
Schwarzbeck	UHAP/ Dipole Antenna	558	Annual	02/13/2011
Korea Engineering	KR-1005L / Chamber	KRAB07063-2CH	Annual	12/31/2009
Schwarzbeck	VULB9160/ TRILOG Antenna	3150	Biennial	12/18/2010
Schwarzbeck	VULB9160/ TRILOG Antenna	3125	Biennial	05/16/2009
Schwarzbeck	BBHA 9120D/ Horn Antenna	147	Biennial	03/26/2010
Schwarzbeck	BBHA 9120D/ Horn Antenna	1201	Biennial	05/02/2009
Agilent	E4440A/Spectrum Analyzer	US45303008	Annual	12/23/2009



5. SUMMARY OF TEST RESULTS

FCC Part Section(s)	Test Description	Test Limit	Test Condition	Test Result
2.1049, 22.917(a), 24.238(a)	Occupied Bandwidth	N/A	CONDUCTED	PASS
2.1051, 22.917(a), 24.238(a)	Band Edge / Spurious and Harmonic Emissions at Antenna Terminal.	$< 43 + \log_{10}(P[\text{Watts}])$ at Band Edge and for all out-of-band emissions		PASS
2.1046	Conducted Output Power	N/A		PASS
24.232(d)	Peak- to- Average Ratio	< 13 dB		PASS
2.1055, 22.355, 24.235	Frequency stability / variation of ambient temperature	< 2.5 ppm		PASS
22.913(a)(2) 24.232(c)	Effective Radiated Power	< 7 Watts max. ERP	RADIATED	PASS
	Equivalent Isotropic Radiated Power	< 2 Watts max. EIRP		PASS
2.1053, 22.917(a), 24.238(a)	Radiated Spurious and Harmonic Emissions	$< 43 + \log_{10}(P[\text{Watts}])$ for all out-of band emissions		PASS



6. SAMPLE CALCULATION

A. ERP Sample Calculation

Mode	Ch./ Freq.		Measured Level(dBm)	Substitute LEVEL(dBm)	Ant. Gain	C.L	Pol.	ERP	
	channel	Freq.(MHz)						W	dBm
GSM850	128	824.20	-11.56	34.28	-8.32	1.17	H	0.30	24.79

ERP = SubstituteLEVEL(dBm) + Ant. Gain – CL(Cable Loss)

- 1) The EUT mounted on a wooden tripod is 0.8 meter above test site ground level.
- 2) During the test , the turn table is rotated and the antenna height is also varied from 1 to 4 meters until the maximum signal is found.
- 3) Record the field strength meter's level.
- 4) Replace the EUT with dipole/Horn antenna that is connected to a calibrated signal generator.
- 5) Increase the signal generator output till the field strength meter's level is equal to the item (3).
- 6) The signal generator output level with Ant. Gain and cable loss are the rating of effective radiated power (ERP).

B. Emission Designator

GSM Emission Designator

Emission Designator = 249KGXW

GSM BW = 249 kHz

G = Phase Modulation

X = Cases not otherwise covered

W = Combination (Audio/Data)

WCDMA Emission Designator

Emission Designator = 4M17F9W

WCDMA BW = 4.17 MHz

F = Frequency Modulation

9 = Composite Digital Info

W = Combination (Audio/Data)

FCC CERTIFICATION REPORT				www.hct.co.kr
Test Report No. HCT-RF09-0313	Date of Issue: March 25, 2009	EUT Type: Dual-Band Dual-Mode GSM/WCDMA Phone with Bluetooth	FCC ID: JYCC790	Page 12 of 53

7. TEST DATA

7.1 Conducted Output Power

A base station simulator was used to establish communication with the EUT. The base station simulator parameters were set to produce the maximum power from the EUT. This device was tested under all configurations and the highest power is reported. Conducted Output Powers of EUT are reported below.

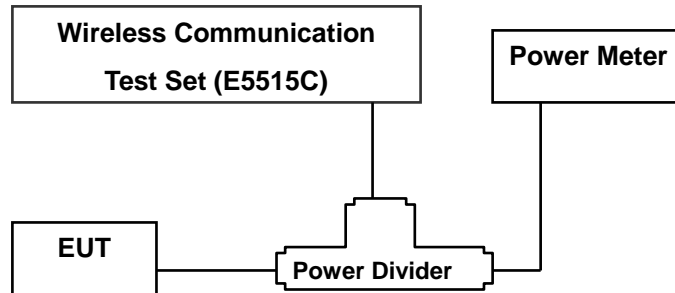

Test Result

Band	Channel	Voice	GPRS Data	
		GSM (dBm)	GPRS 1 TX Slot (dBm)	GPRS 2 TX Slot (dBm)
GSM 850	128	32.63	32.60	32.56
	190	32.73	32.70	32.65
	251	32.74	32.70	32.65
GSM 1900	512	29.64	29.63	29.54
	661	29.81	29.81	29.73
	810	29.72	29.72	29.66

(GSM Conducted Output Powers)

Band	Channel	EDGE Data	
		EDGE 1 TX Slot (dBm)	EDGE 2 TX Slot (dBm)
GSM 850	128	26.70	26.66
	190	26.79	26.76
	251	26.80	26.77
GSM 1900	512	25.67	25.62
	661	25.85	25.81
	810	25.77	25.74

(GSM EDGE Conducted Output Powers)

Band	Channel	HSDPA INACTIVE		HSDPA ACTIVE
		12.2kbps RMC (dBm)	12.2kbps AMR (dBm)	12.2kbps RMC (dBm)
WCDMA 850	4132	24.60	24.69	20.72
	4183	24.66	24.68	20.63
	4233	24.64	24.65	20.68
WCDMA 1900	9262	24.13	24.24	20.44
	9400	24.38	24.36	20.39
	9538	24.67	24.66	20.68

(WCDMA Conducted Output Powers)

7.2 Peak-to-Average Ratio

- Plots of the EUT's Peak- to- Average Ratio are shown Page 30, 33.



7.3 Effective Radiated Power Output (GSM / WCDMA)

(GSM850 Mode)

Ch./ Freq.		Measured Level(dBm)	Substitute LEVEL (dBm)	Ant. Gain (dBd)	C.L	Pol.	ERP	
channel	Freq.(MHz)						W	dBm
128	824.20	-9.80	36.04	-8.32	1.17	H	0.45	26.55
190	836.60	-7.78	38.71	-8.22	1.19	H	0.85	29.30
251	848.80	-6.24	40.88	-8.12	1.20	H	1.43	31.56
EDGE 251	848.80	-9.15	37.97	-8.12	1.20	H	0.73	28.65

(WCDMA850 Mode)

Ch./ Freq.		Measured Level(dBm)	Substitute LEVEL (dBm)	Ant. Gain (dBd)	C.L	Pol.	ERP	
channel	Freq.(MHz)						W	dBm
4132	826.40	-13.49	32.46	-8.30	1.17	V	0.20	22.99
4183	836.40	-12.24	34.25	-8.22	1.19	V	0.30	24.84
4233	846.60	-12.06	34.95	-8.14	1.20	V	0.36	25.61

Note: Standard batteries are the only options for this phone

NOTES:

Effective Radiated Power Output Measurements by Substitution Method
 according to ANSI/TIA/EIA-603-C-2004, Aug. 17, 2004:

The EUT was placed on a wooden turn table 3-meters from the receive antenna. The receive antenna height and turntable rotation was adjusted for the highest reading on the receive spectrum analyzer. For CDMA signals, a peak detector is used, with RBW = VBW = 3 MHz. For WCDMA signals, a peak detector is used, with RBW = VBW = 5MHz. For AMPS, GSM, and NADC TDMA signals, a peak detector is used, with RBW = VBW = 1 MHz. A half-wave dipole was substituted in place of the EUT. This dipole antenna was driven by a signal generator and the level of the signal generator was adjusted to obtain the same receive spectrum analyzer reading. The conducted power at the terminals of the dipole is measured. The ERP is recorded. This device was tested under all configurations and the highest power is reported in WCDMA mode with HSDPA Inactive at 12.2 kbps RMC and TPC bits all set to "1" and in GSM mode and using a Power Control Level of "0" in the PCS Band and "5" in the Cellular Band. This unit was tested with its standard battery.



7.4 Equivalent Isotropic Radiated Power (E.I.R.P.) (GSM)

(GSM1900 Mode)

Ch./ Freq.		Measured Level(dBm)	Substitute LEVEL (dBm)	Ant. Gain (dBi)	C.L	Pol.	EIRP	
channel	Freq.(MHz)						W	dBm
512	1,850.20	-12.14	19.47	10.05	1.91	H	0.58	27.60
661	1,880.00	-11.36	20.46	10.05	1.95	H	0.72	28.56
810	1,909.80	-11.60	20.30	10.06	1.97	H	0.69	28.39
EDGE 661	1,880.00	-12.11	19.71	10.05	1.95	H	0.60	27.81

(WCDMA1900 Mode)

Ch./ Freq.		Measured Level(dBm)	Substitute LEVEL (dBm)	Ant. Gain (dBi)	C.L	Pol.	EIRP	
channel	Freq.(MHz)						W	dBm
9262	1,852.40	-13.31	18.30	10.05	1.91	V	0.44	26.44
9400	1,880.00	-14.60	17.22	10.05	1.95	V	0.34	25.32
9538	1,907.60	-14.23	17.69	10.06	1.97	V	0.38	25.78

Note: Standard batteries are the only options for this phone

NOTES:

Equivalent Isotropic Radiated Power Measurements by Substitution Method according to ANSI/TIA/EIA-603-C-2004, Aug. 17, 2004:

The EUT was placed on a wooden turn table 3-meters from the receive antenna. The receive antenna height and turntable rotation was adjusted for the highest reading on the receive spectrum analyzer. For CDMA signals, a peak detector is used, with RBW = VBW = 3 MHz. For WCDMA signals, a peak detector is used, with RBW = VBW = 5MHz. For AMPS, GSM, and NADC TDMA signals, a peak detector is used, with RBW = VBW = 1 MHz. A Horn antenna was substituted in place of the EUT. This Horn antenna was driven by a signal generator and the level of the signal generator was adjusted to obtain the same receive spectrum analyzer reading. The conducted power at the terminals of the Horn antenna is measured. The difference between the gain of the horn and an isotropic antenna is taken into consideration and the EIRP is recorded.

This device was tested under all configurations and the highest power is reported in WCDMA mode with HSDPA Inactive at 12.2 kbps RMC and TPC bits all set to "1" and in GSM mode and using a Power Control Level of "0" in the PCS Band and "5" in the Cellular Band. This unit was tested with its standard battery.

FCC CERTIFICATION REPORT				www.hct.co.kr
Test Report No. HCT-RF09-0313	Date of Issue: March 25, 2009	EUT Type: Dual-Band Dual-Mode GSM/WCDMA Phone with Bluetooth	FCC ID: JYCC790	Page 16 of 53



7.5 Radiated Spurious Emissions

7.5.1 Radiated Spurious Emissions (GSM850)

- MEASURED OUTPUT POWER: 31.56 dBm = 1.432 W
- MODULATION SIGNAL: GSM850
- DISTANCE: 3 meters
- LIMIT: $-(43 + 10 \log_{10}(W)) =$ - 44.56 dBc

Ch.	Freq.(MHz)	Measured Level [dBm]	Ant. Gain (dBd)	Substitute Level [dBm]	C.L	Pol.	ERP (dBm)	dBc
128 (824.2)	1,648.40	-45.70	7.09	-56.23	1.73	V	-50.87	-82.43
	2,472.60	-44.75	8.12	-51.86	2.28	H	-46.02	-77.58
	3,296.80	-50.02	9.72	-57.60	2.57	V	-50.45	-82.01
190 (836.6)	1,673.20	-44.67	7.23	-55.43	1.79	V	-49.99	-81.55
	2,509.80	-44.69	8.14	-51.82	2.33	H	-46.01	-77.57
	3,346.40	-49.28	9.99	-57.31	2.66	V	-49.98	-81.54
251 (848.8)	1,697.60	-43.20	7.41	-53.81	1.83	V	-48.23	-79.79
	2,546.40	-41.02	8.21	-48.30	2.34	H	-42.43	-73.99
	3,395.20	-50.88	9.91	-58.51	2.85	V	-51.45	-83.01

NOTES: Radiated Spurious Emission Measurements at 3 meters by Substitution Method
according to ANSI/TIA/EIA-603-C-2004, Aug. 17, 2004:



7.5.2 Radiated Spurious Emissions (GSM1900)

- MEASURED OUTPUT POWER: 28.56 dBm = 0.718 W
- MODULATION SIGNAL: GSM1900
- DISTANCE: 3 meters
- LIMIT: $-(43 + 10 \log_{10}(W)) =$ - 41.56 dBc

Ch.	Freq.(MHz)	Measured Level [dBm]	Ant. Gain (dBi)	Substitute Level [dBm]	C.L	Pol.	EIRP (dBm)	dBc
512 (1850.2)	3,700.40	-52.15	12.46	-58.42	2.73	V	-48.69	-77.25
	5,550.60	-50.07	12.70	-51.65	3.60	V	-42.55	-71.11
	7,400.80	-56.07	11.36	-47.19	3.88	H	-39.71	-68.27
661 (1880.0)	3,760.00	-52.93	12.47	-58.90	2.73	V	-49.16	-77.72
	5,640.00	-48.57	10.60	-48.07	3.60	V	-41.07	-69.63
	7,520.00	-55.97	11.33	-46.87	3.88	V	-39.42	-67.98
810 (1909.8)	3,819.60	-52.35	12.49	-58.23	2.73	V	-48.47	-77.03
	5,729.40	-46.46	12.80	-47.77	3.60	H	-38.57	-67.13
	7,639.20	-56.11	11.30	-46.78	3.88	H	-39.36	-67.92

NOTES: Radiated Spurious Emission Measurements at 3 meters by Substitution Method
according to ANSI/TIA/EIA-603-C-2004, Aug. 17, 2004:



7.5.3 Radiated Spurious Emissions (WCDMA850)

- MEASURED OUTPUT POWER: 25.61 dBm = 0.364 W
- MODULATION SIGNAL: WCDMA850
- DISTANCE: 3 meters
- LIMIT: - (43 + 10 log₁₀ (W)) = - 38.61 dBc

Ch.	Freq.(MHz)	Measured Level [dBm]	Ant. Gain (dBd)	Substitute Level [dBm]	C.L	Pol.	ERP (dBm)	dBc
4,132 (826.4)	1,652.80	-53.54	7.09	-64.10	1.73	H	-58.74	-81.81
	2,479.20	-55.23	8.12	-62.35	2.28	H	-56.51	-79.58
	3,305.60	-53.67	9.72	-61.23	2.57	H	-54.08	-77.15
4,183 (836.6)	1,673.20	-53.18	7.23	-63.94	1.79	H	-58.50	-81.57
	2,509.80	-55.21	8.14	-62.34	2.33	V	-56.53	-79.60
	3,346.40	-53.66	9.99	-61.69	2.66	H	-54.36	-77.43
4,233 (846.6)	1,693.20	-55.03	7.41	-65.69	1.83	V	-60.11	-83.18
	2,539.80	-55.36	8.21	-62.62	2.34	V	-56.75	-79.82
	3,386.40	-54.78	9.91	-62.43	2.85	H	-55.37	-78.44

NOTES: Radiated Spurious Emission Measurements at 3 meters by Substitution Method
according to ANSI/TIA/EIA-603-C-2004, Aug. 17, 2004:



7.5.4 Radiated Spurious Emissions (WCDMA1900)

- MEASURED OUTPUT POWER: 26.44 dBm = 0.441 W
- MODULATION SIGNAL: WCDMA850
- DISTANCE: 3 meters
- LIMIT: $-(43 + 10 \log_{10}(W)) =$ - 39.44 dBc

Ch.	Freq.(MHz)	<u>Measured Level</u> [dBm]	Ant. Gain (dBi)	<u>Substitute</u> <u>Level</u> [dBm]	C.L	Pol.	EIRP (dBm)	dBc
9262 (1852.4)	3,704.80	-42.51	12.46	-48.75	2.73	V	-39.02	-64.17
	5,557.20	-55.79	12.71	-57.40	3.60	H	-48.29	-73.44
	7,409.60	-55.79	11.36	-46.90	3.88	H	-39.42	-64.57
9400 (1880.0)	3,760.00	-44.76	12.47	-50.73	2.73	V	-40.99	-66.14
	5,640.00	-56.01	12.75	-57.66	3.60	H	-48.51	-73.66
	7,520.00	-55.29	11.33	-46.19	3.88	V	-38.74	-63.89
9538 (1907.6)	3,815.20	-42.63	12.46	-48.50	2.73	V	-38.77	-63.92
	5,722.80	-55.54	12.79	-56.87	3.60	H	-47.68	-72.83
	7,630.40	-55.71	11.30	-46.39	3.88	V	-38.97	-64.12

NOTES: Radiated Spurious Emission Measurements at 3 meters by Substitution Method according to ANSI/TIA/EIA-603-C-2004, Aug. 17, 2004:



7.6 Frequency stability / variation of ambient temperature

7.6.1 FREQUENCY STABILITY (GSM850)

OPERATING FREQUENCY: 836,600,000 Hz
 CHANNEL: 190
 REFERENCE VOLTAGE: 3.7 VDC
 DEVIATION LIMIT: ± 0.000 25 % or 2.5 ppm

Voltage (%)	Power (VDC)	Temp. (°C)	Frequency (Hz)	Frequency Error (Hz)	Deviation (%)	ppm
100%	3.700	+20(Ref)	836 599 978	-21.56	-0.000 003	-0.026
100%		-30	836 600 001	1.42	0.000 000	0.002
100%		-20	836 599 990	-9.92	-0.000 001	-0.012
100%		-10	836 600 001	0.78	0.000 000	0.001
100%		0	836 599 985	-14.78	-0.000 002	-0.018
100%		+10	836 599 996	-3.76	0.000 000	-0.004
100%		+20	836 599 988	-12.34	-0.000 001	-0.015
100%		+30	836 600 005	5.44	0.000 001	0.007
100%		+40	836 599 986	-13.59	-0.000 002	-0.016
100%		+50	836 599 997	-2.69	0.000 000	-0.003
115%		4.255	+20	836 599 987	-13.05	-0.000 002
Batt. Endpoint	3.400	+20	836 599 996	-4.37	-0.000 001	-0.005

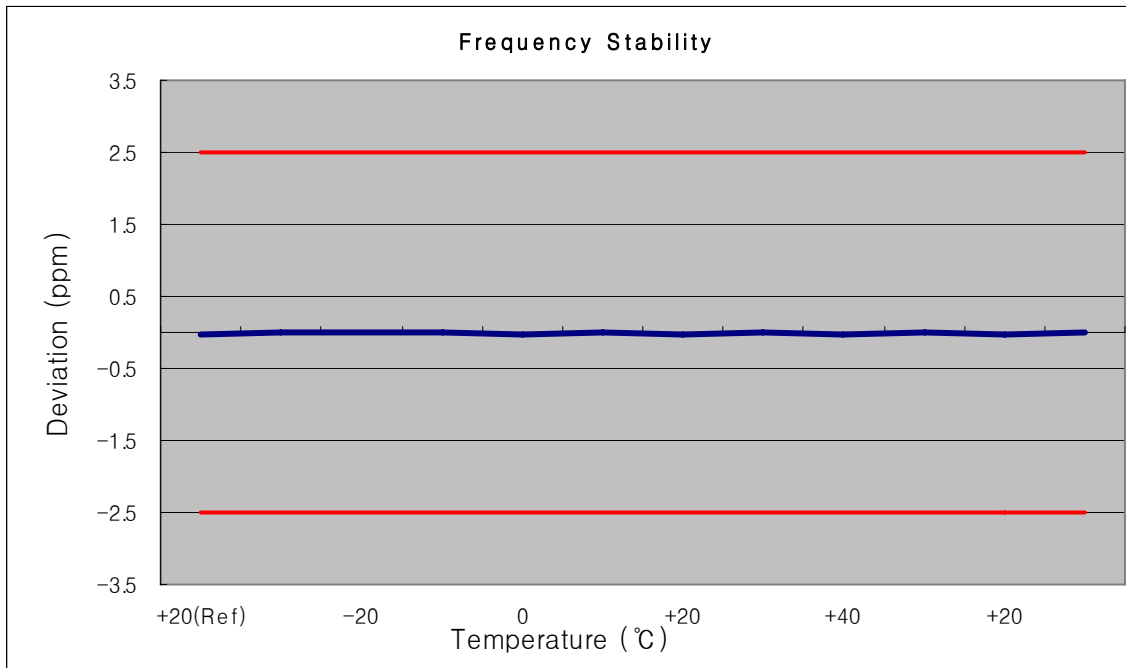



7.6.2 FREQUENCY STABILITY (GSM1900)

OPERATING FREQUENCY: 1880,000,000 Hz
 CHANNEL: 661
 REFERENCE VOLTAGE: 3.7 VDC
 DEVIATION LIM IT: ± 0.000 25 % or 2.5 ppm

Voltage (%)	Power (VDC)	Temp. (°C)	Frequency (Hz)	Frequency Error (Hz)	Deviation (%)	ppm
100%	3.700	+20(Ref)	1879 999 962	-38.16	-0.000 002	-0.020
100%		-30	1879 999 985	-14.55	-0.000 001	-0.008
100%		-20	1879 999 956	-43.87	-0.000 002	-0.023
100%		-10	1879 999 983	-16.73	-0.000 001	-0.009
100%		0	1879 999 944	-56.31	-0.000 003	-0.030
100%		+10	1879 999 991	-9.33	0.000 000	-0.005
100%		+20	1879 999 962	-38.46	-0.000 002	-0.020
100%		+30	1879 999 981	-18.69	-0.000 001	-0.010
100%		+40	1879 999 952	-47.73	-0.000 003	-0.025
100%		+50	1879 999 972	-27.54	-0.000 001	-0.015
115%	4.255	+20	1879 999 959	-40.84	-0.000 002	-0.022
Batt. Endpoint	3.400	+20	1879 999 985	-14.76	-0.000 001	-0.008

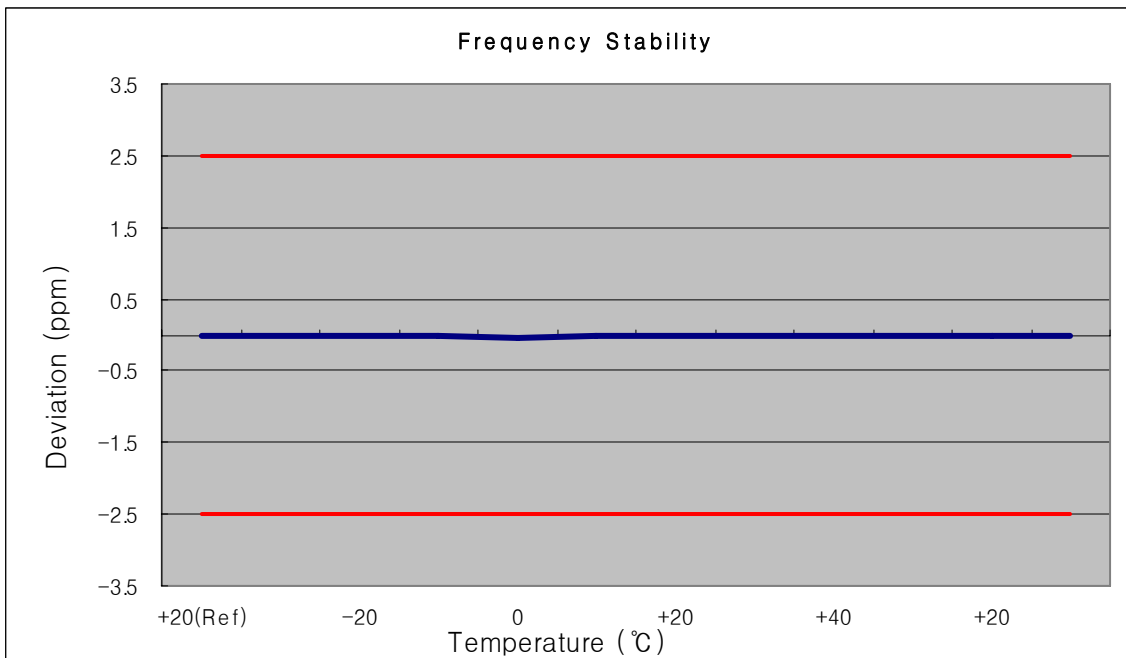



7.6.3 FREQUENCY STABILITY (WCDMA850)

OPERATING FREQUENCY: 836,600,000 Hz
 CHANNEL: 4183
 REFERENCE VOLTAGE: 3.7 VDC
 DEVIATION LIMIT: ± 0.000 25 % or 2.5 ppm

Voltage (%)	Power (VDC)	Temp. (°C)	Frequency (Hz)	Frequency Error (Hz)	Deviation (%)	ppm
100%	3.700	+20(Ref)	836 600 019	18.81	0.000 022	0.022
100%		-30	836 599 992	-7.93	-0.000 009	-0.009
100%		-20	836 600 004	4.35	0.000 005	0.005
100%		-10	836 600 017	17.00	0.000 020	0.020
100%		0	836 599 989	-10.98	-0.000 013	-0.013
100%		+10	836 600 011	11.16	0.000 013	0.013
100%		+20	836 600 007	7.36	0.000 009	0.009
100%		+30	836 600 023	22.77	0.000 027	0.027
100%		+40	836 599 989	-11.12	-0.000 013	-0.013
100%		+50	836 600 013	12.63	0.000 015	0.015
115%	4.255	+20	836 599 987	-13.17	-0.000 016	-0.016
Batt. Endpoint	3.400	+20	836 600 005	5.07	0.000 006	0.006

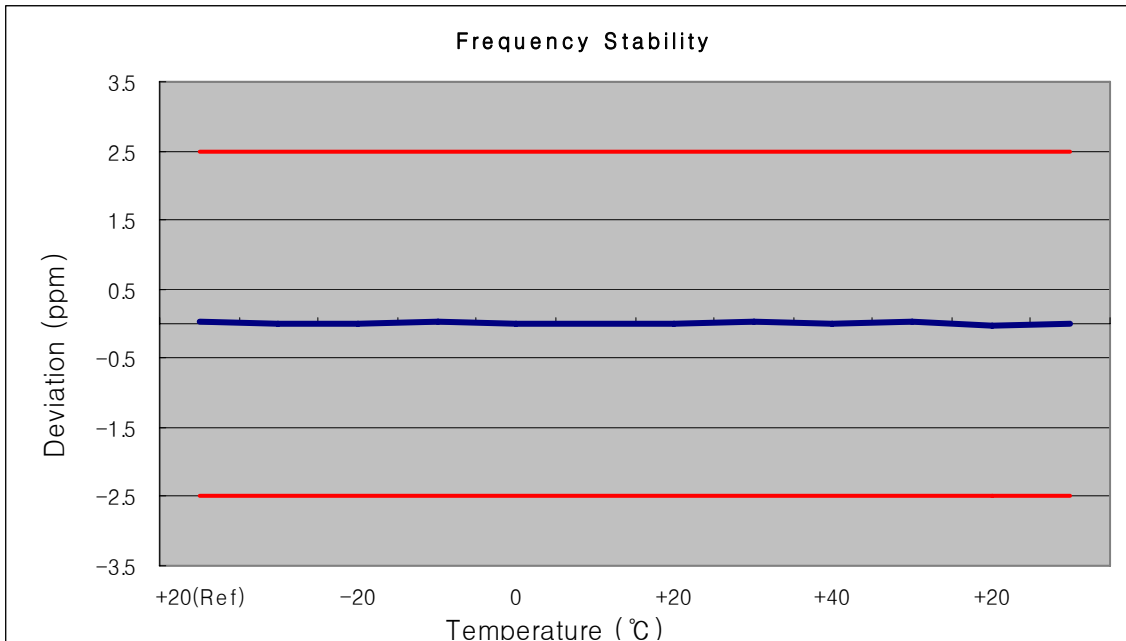



7.6.4 FREQUENCY STABILITY (WCDMA1900)

OPERATING FREQUENCY: 1,880,000,000 Hz
 CHANNEL: 9400
 REFERENCE VOLTAGE: 3.7 VDC
 DEVIATION LIM IT: ± 0.000 25 % or 2.5 ppm

Voltage (%)	Power (VDC)	Temp. (°C)	Frequency (Hz)	Frequency Error (Hz)	Deviation (%)	ppm
100%	3.700	+20(Ref)	1,879,999,941	-58.63	-0.000003	-0.031
100%		-30	1,880,000,020	20.39	0.000001	0.011
100%		-20	1,879,999,981	-19.39	-0.000001	-0.010
100%		-10	1,880,000,020	19.64	0.000001	0.010
100%		0	1,880,000,020	19.88	0.000001	0.011
100%		+10	1,879,999,972	-28.25	-0.000002	-0.015
100%		+20	1,880,000,016	16.11	0.000001	0.009
100%		+30	1,879,999,975	-25.42	-0.000001	-0.014
100%		+40	1,880,000,016	16.34	0.000001	0.009
100%		+50	1,879,999,981	-18.73	-0.000001	-0.010
115%	4.255	+20	1,879,999,979	-21.19	-0.000001	-0.011
Batt. Endpoint	3.400	+20	1,879,999,969	-30.72	-0.000002	-0.016

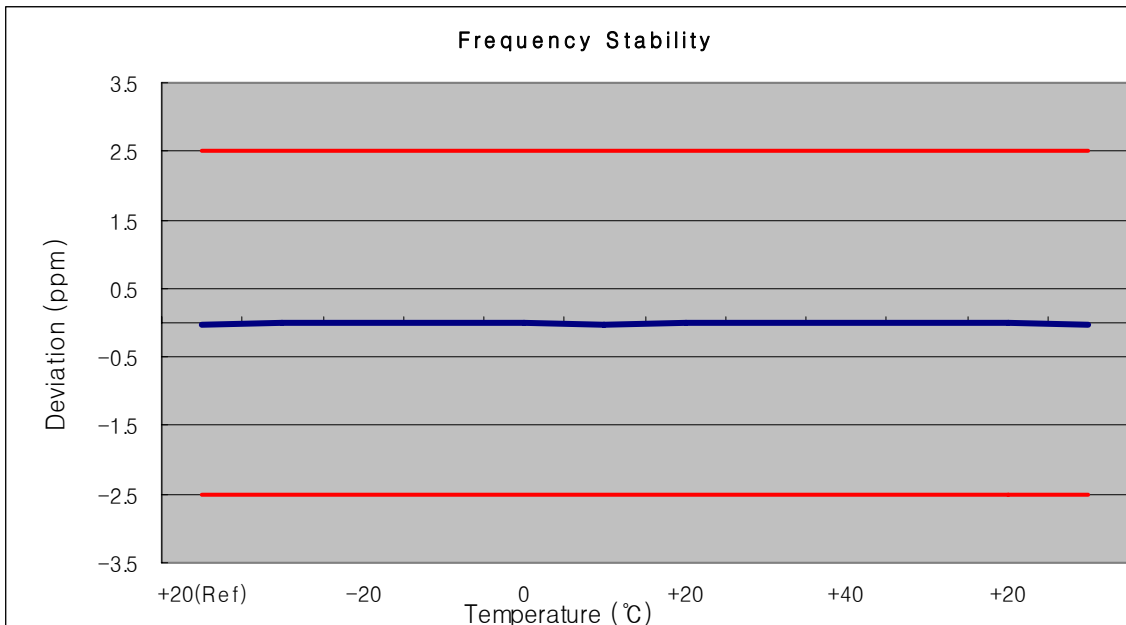



8. TEST PLOTS

FCC CERTIFICATION REPORT				www.hct.co.kr
Test Report No. HCT-RF09-0313	Date of Issue: March 25, 2009	EUT Type: Dual-Band Dual-Mode GSM/WCDMA Phone with Bluetooth	FCC ID: JYCC790	Page 25 of 53

■ GSM850 MODE (128 CH.) Occupied Bandwidth

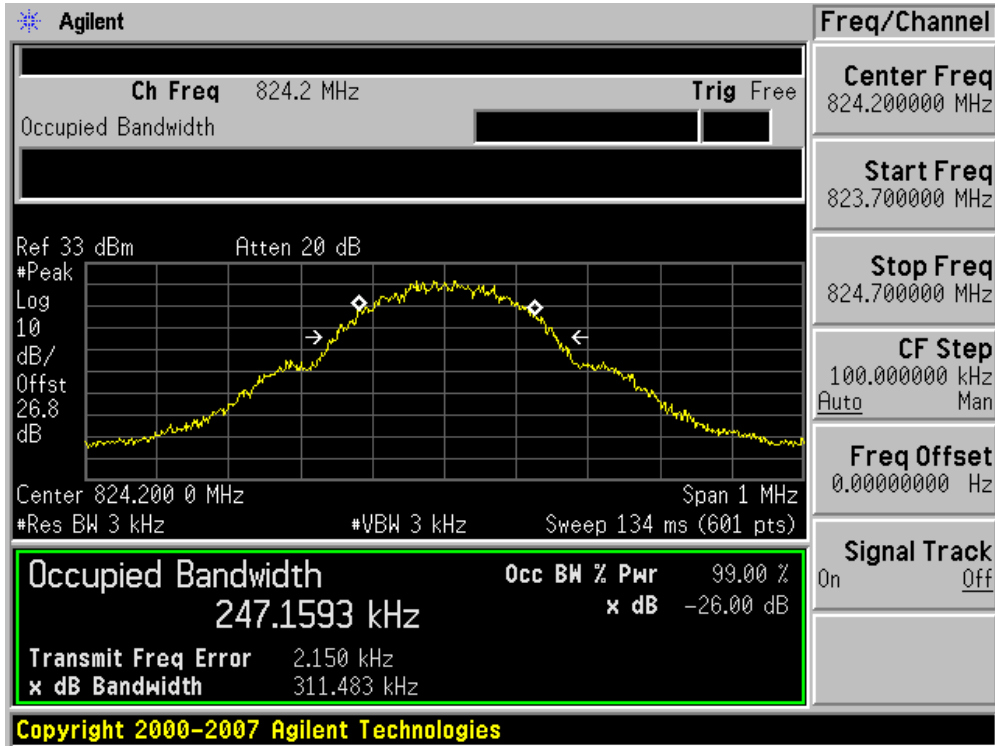

■ GSM850 MODE (190 CH.) Occupied Bandwidth

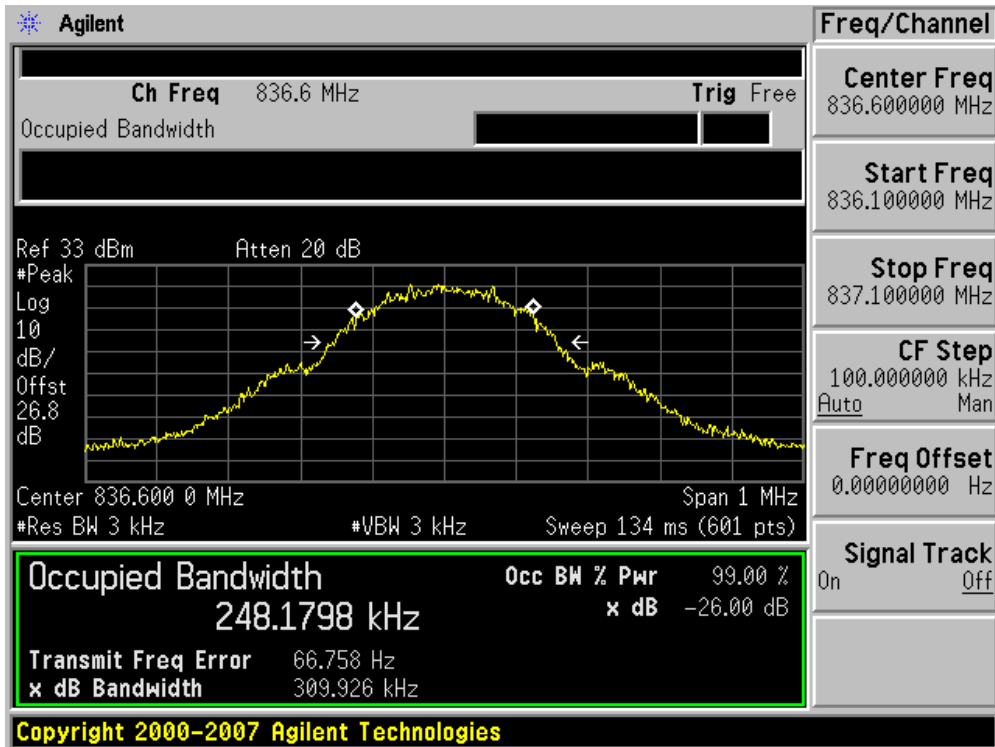

■ GSM850 MODE (251 CH.) Occupied Bandwidth

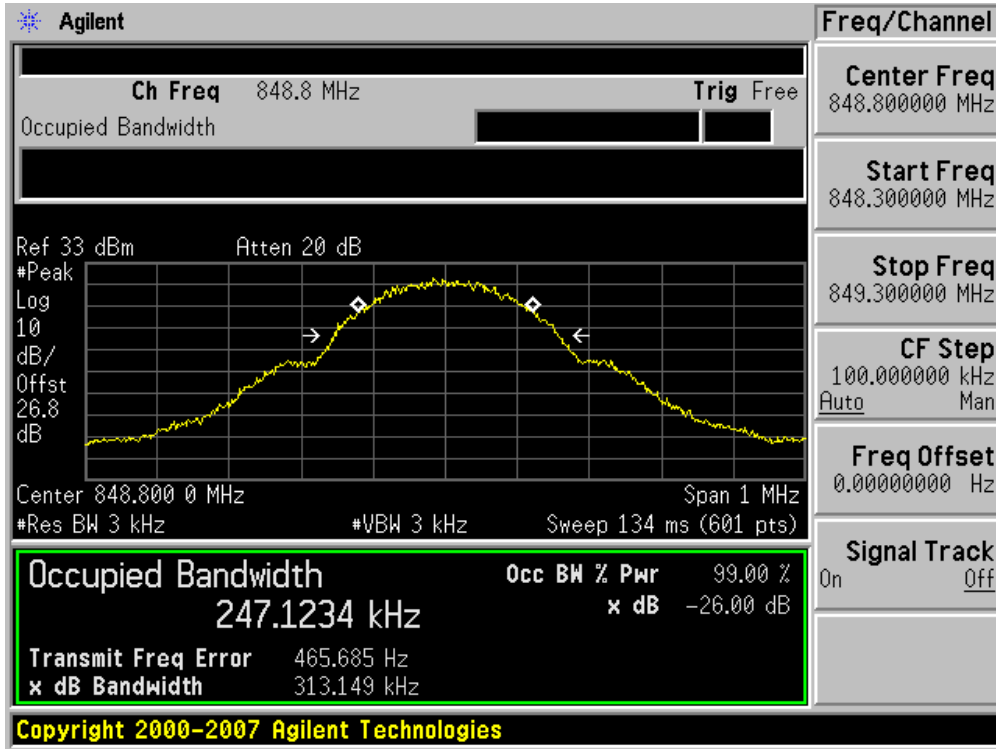

■ GSM850 EDGE (190 CH.) Occupied Bandwidth

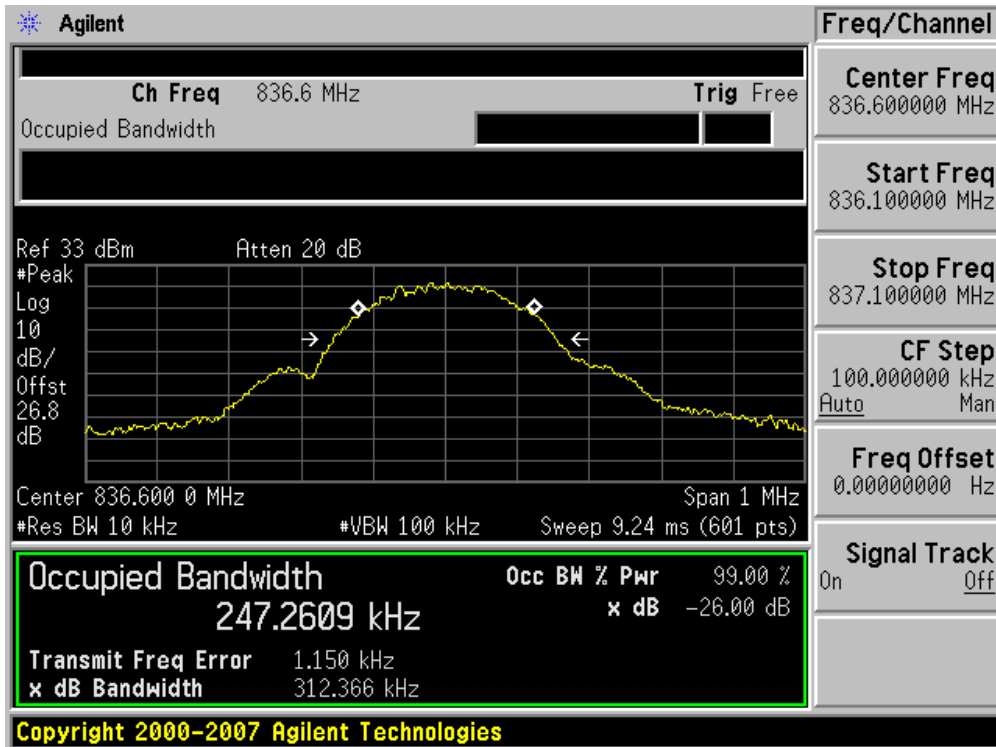

■ GSM1900 MODE (512 CH.) Occupied Bandwidth

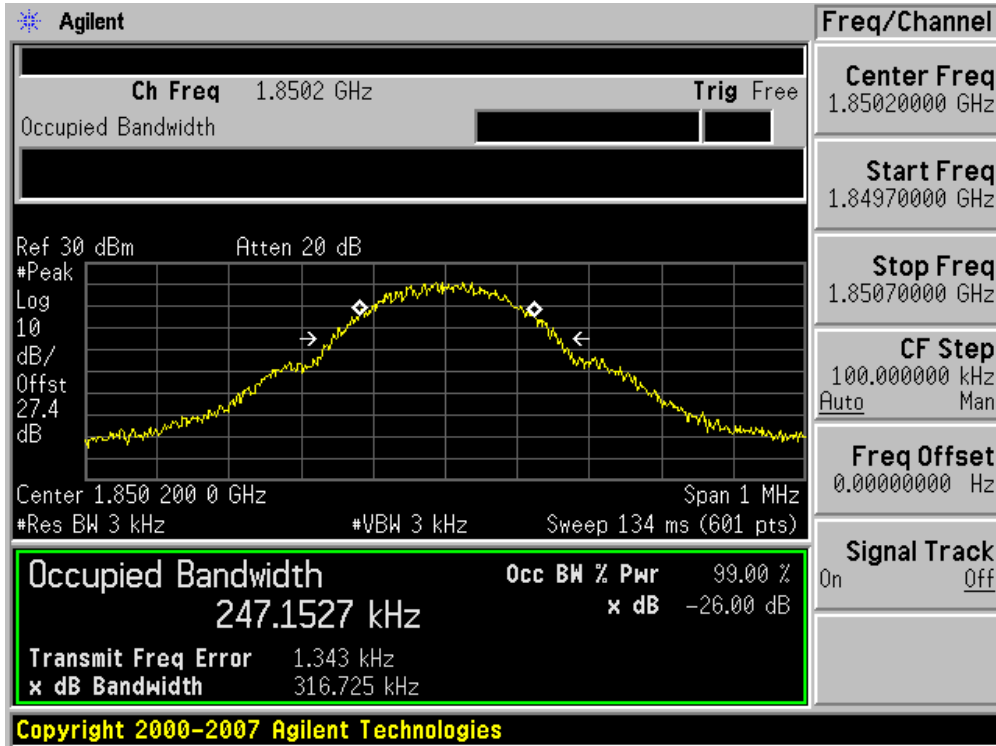

■ GSM1900 MODE (661 CH.) Occupied Bandwidth

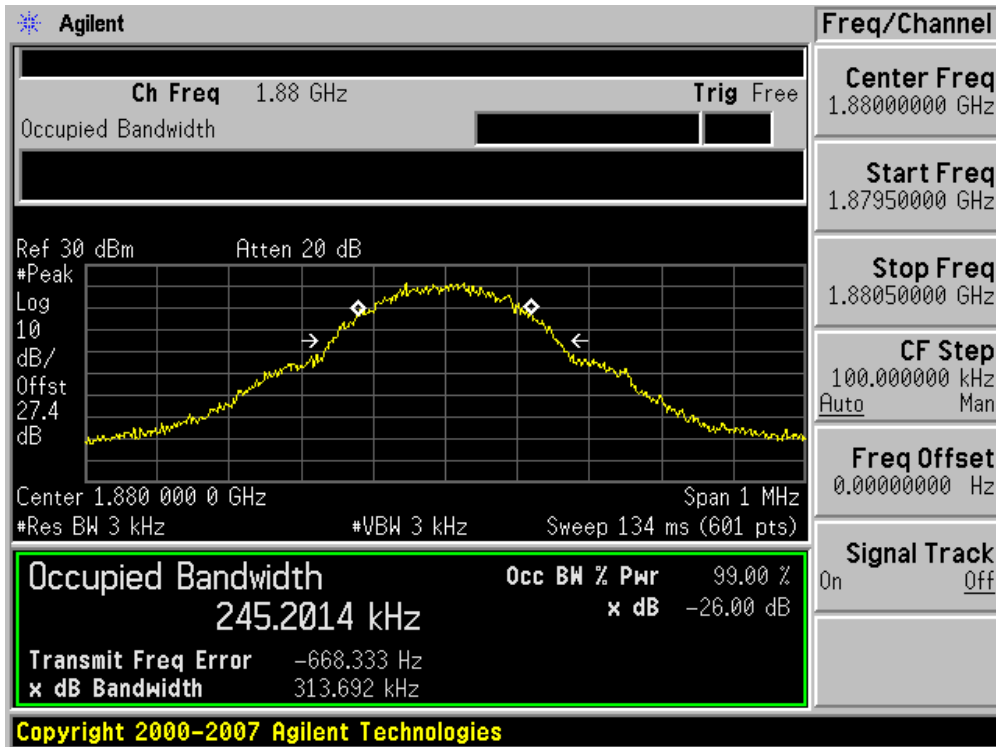



■ GSM1900 MODE (810 CH.) Occupied Bandwidth

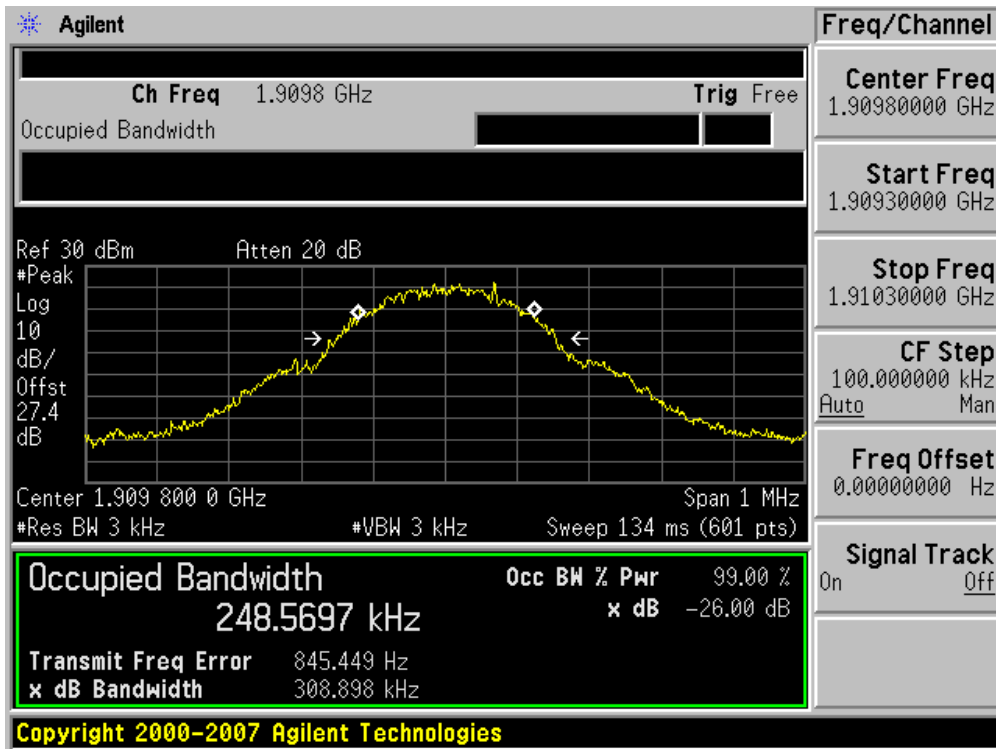

■ GSM1900 EDGE (810 CH.) Occupied Bandwidth

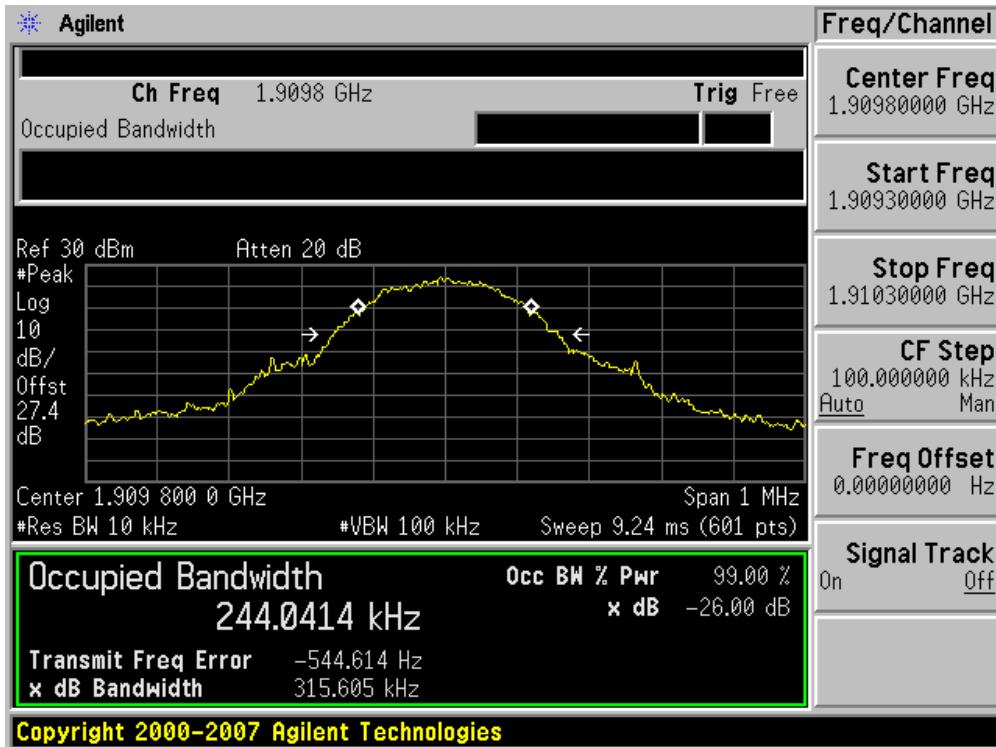

■ GSM1900 MODE (661 CH.) Peak-to-Average Ratio

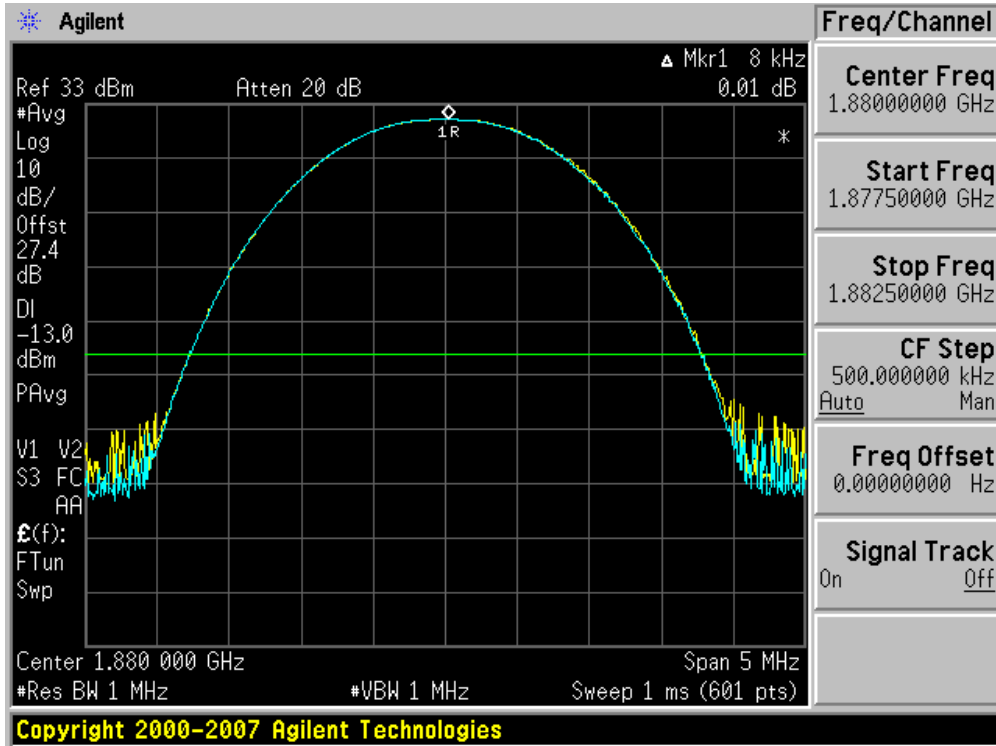

■ WCDMA850 MODE (4132 CH.) Occupied Bandwidth

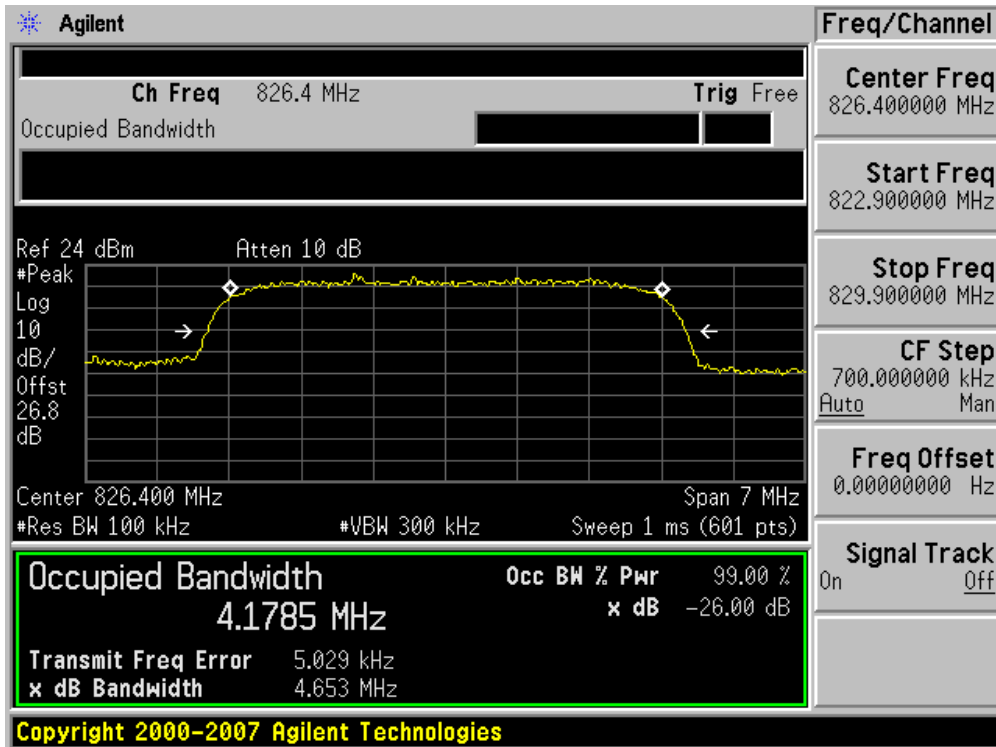



■ WCDMA850 MODE (4183 CH.) Occupied Bandwidth

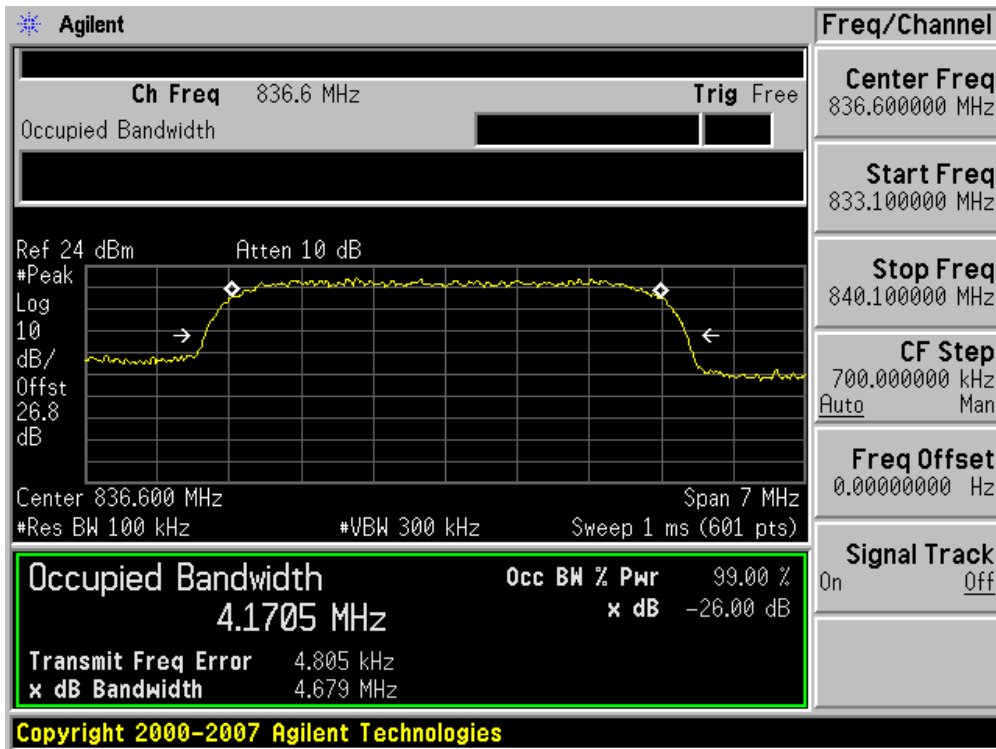

■ WCDMA850MODE (4233 CH.) Occupied Bandwidth

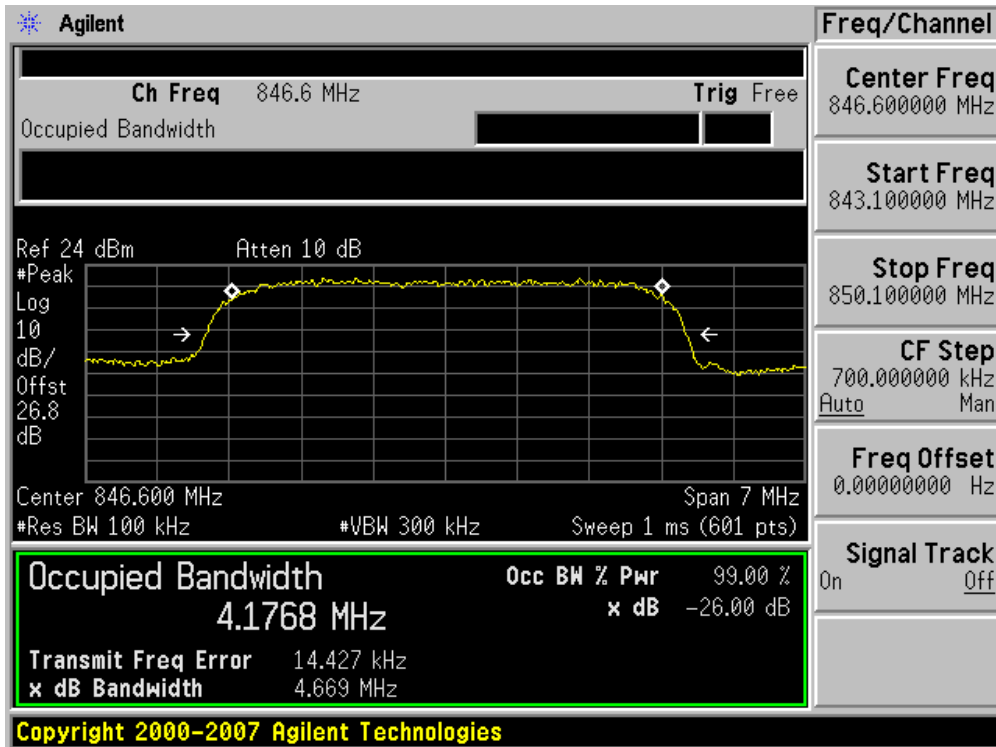



■ WCDMA1900 MODE (9262 CH.) Occupied Bandwidth

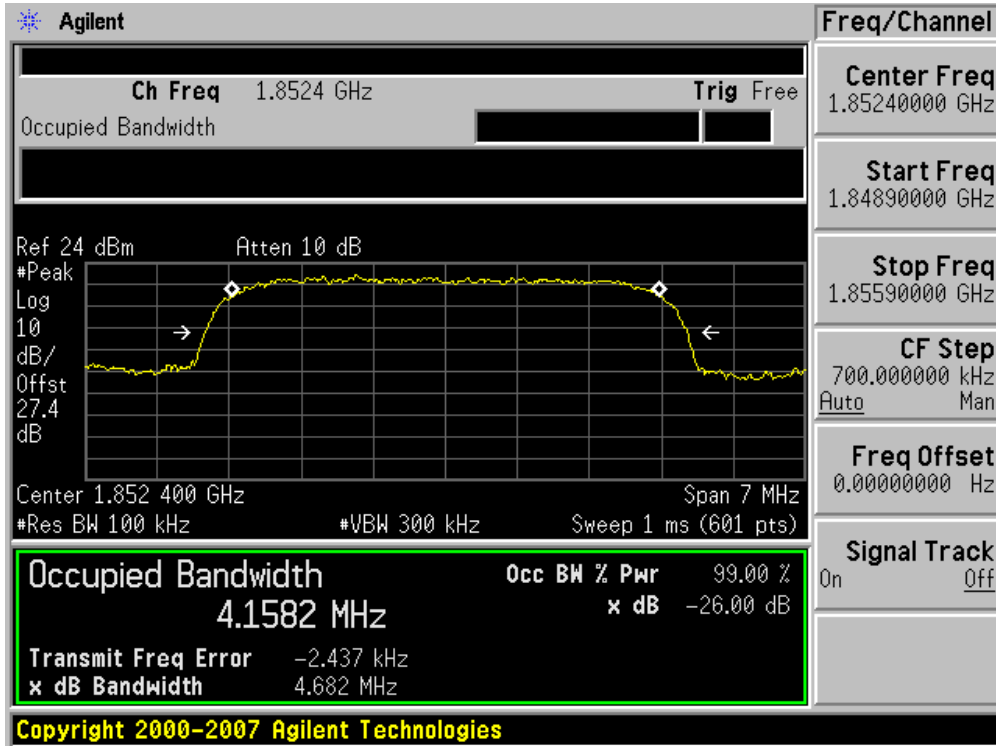

■ WCDMA1900 MODE (9400 CH.) Occupied Bandwidth

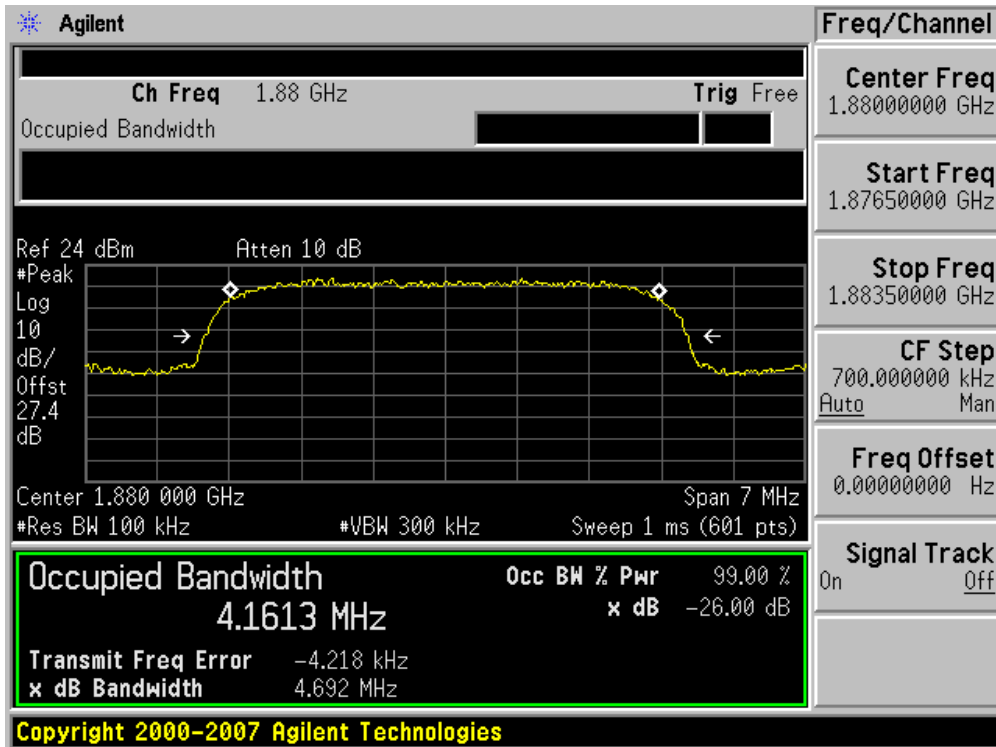

■ WCDMA1900 MODE (9538 CH.) Occupied Bandwidth

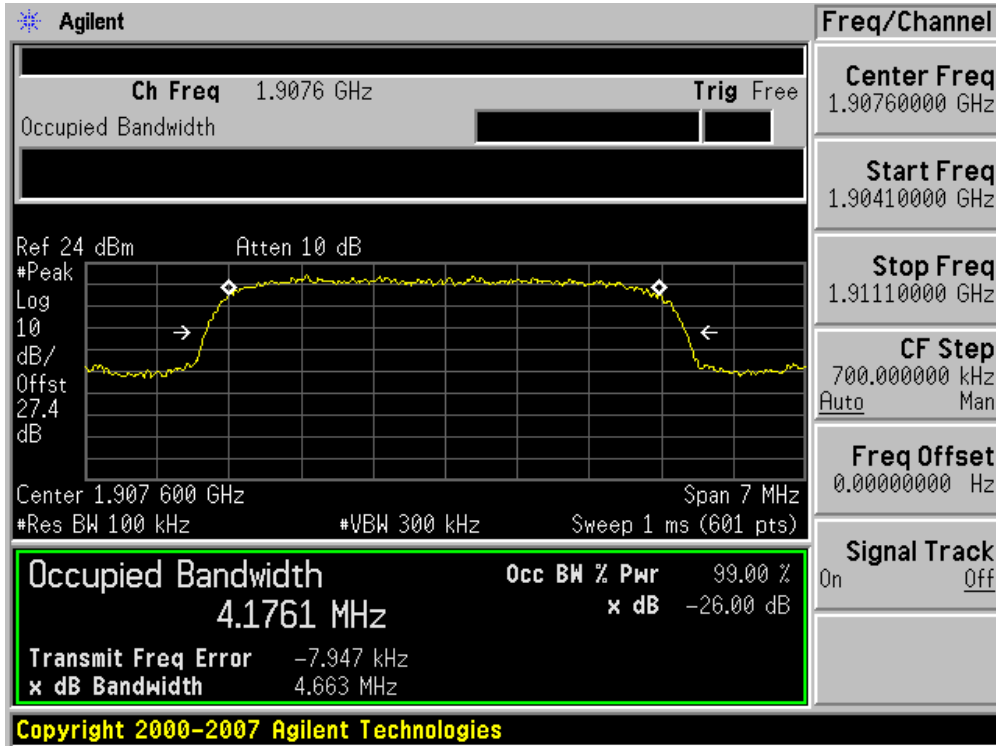

■ WCDMA1900 MODE (9400 CH.) Peak-to-Average Ratio

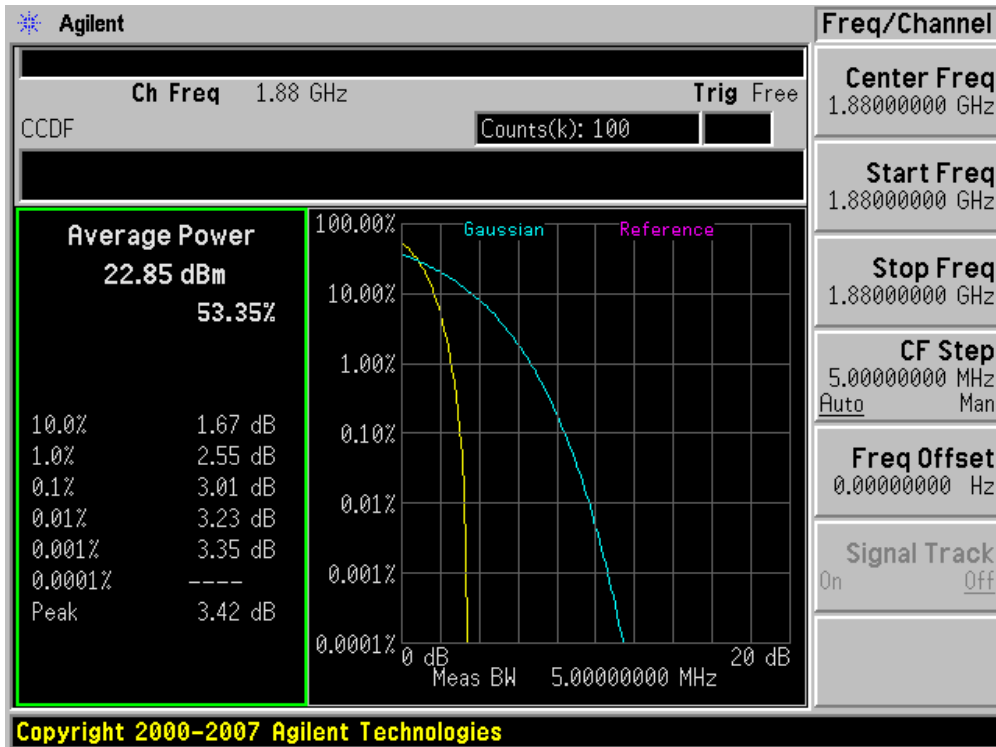

■ GSM850 MODE (128 CH.) Block Edge

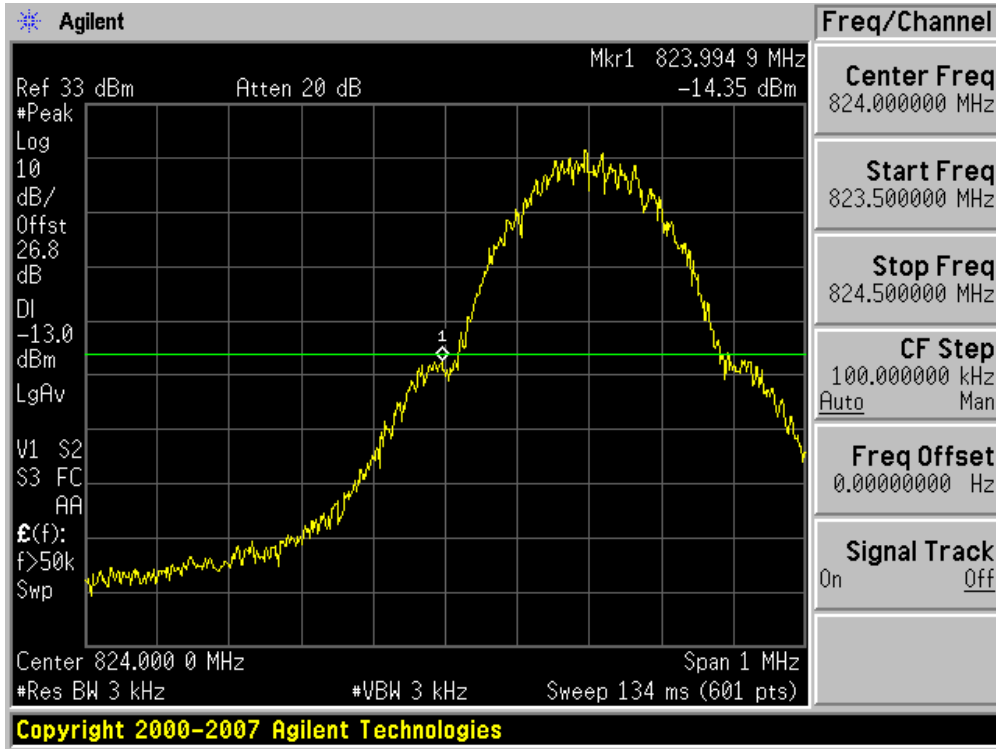

■ GSM850 MODE (251 CH.) Block Edge

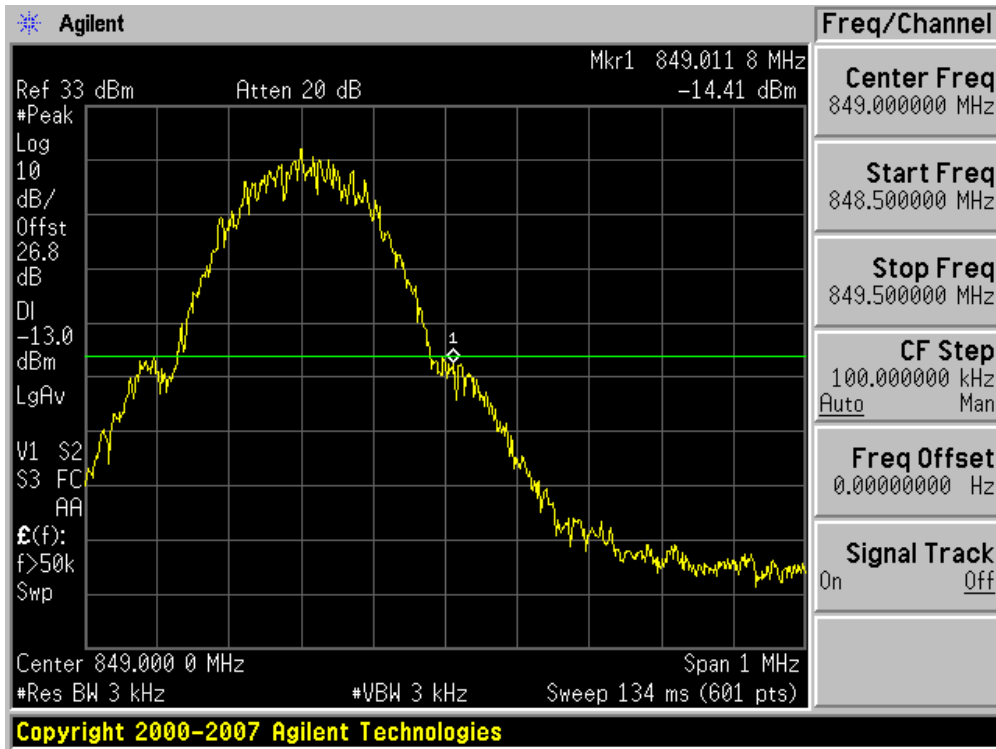

■ GSM850 EDGE MODE (128 CH.) Block Edge

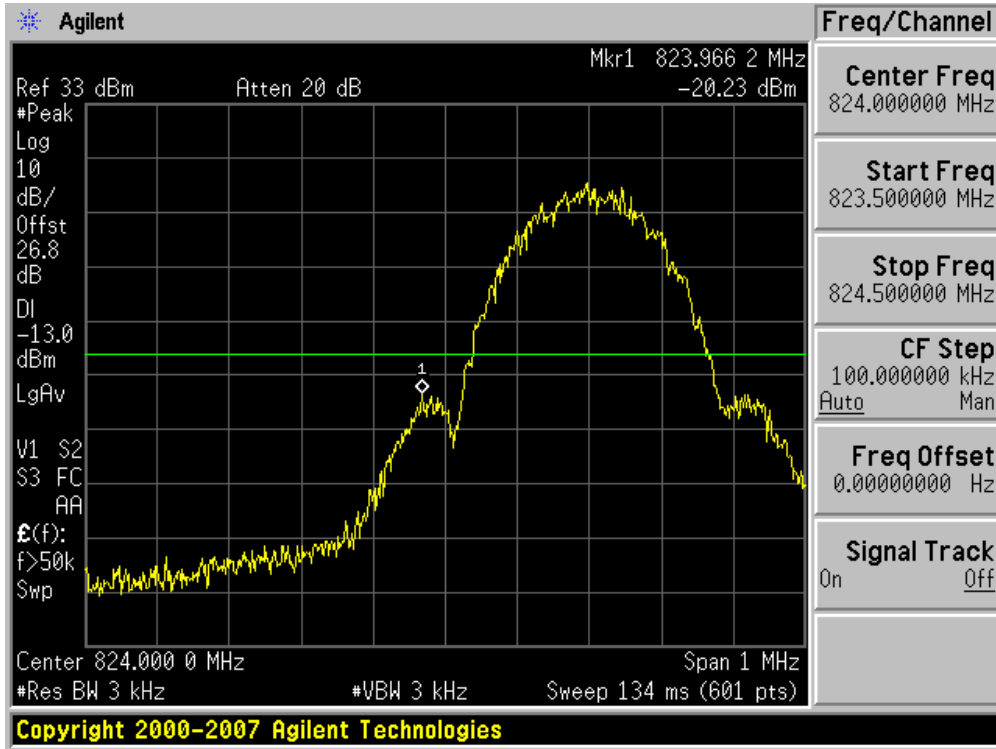

■ GSM850 EDGE MODE (251 CH.) Block Edge

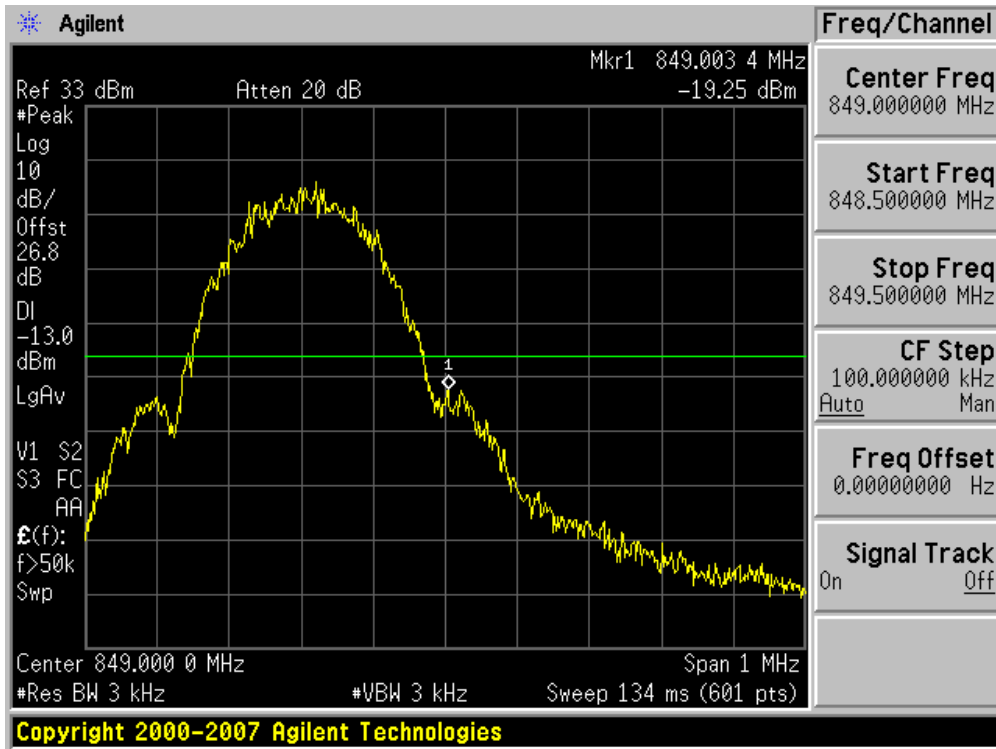

■ GSM1900 MODE (512 CH.) Block Edge

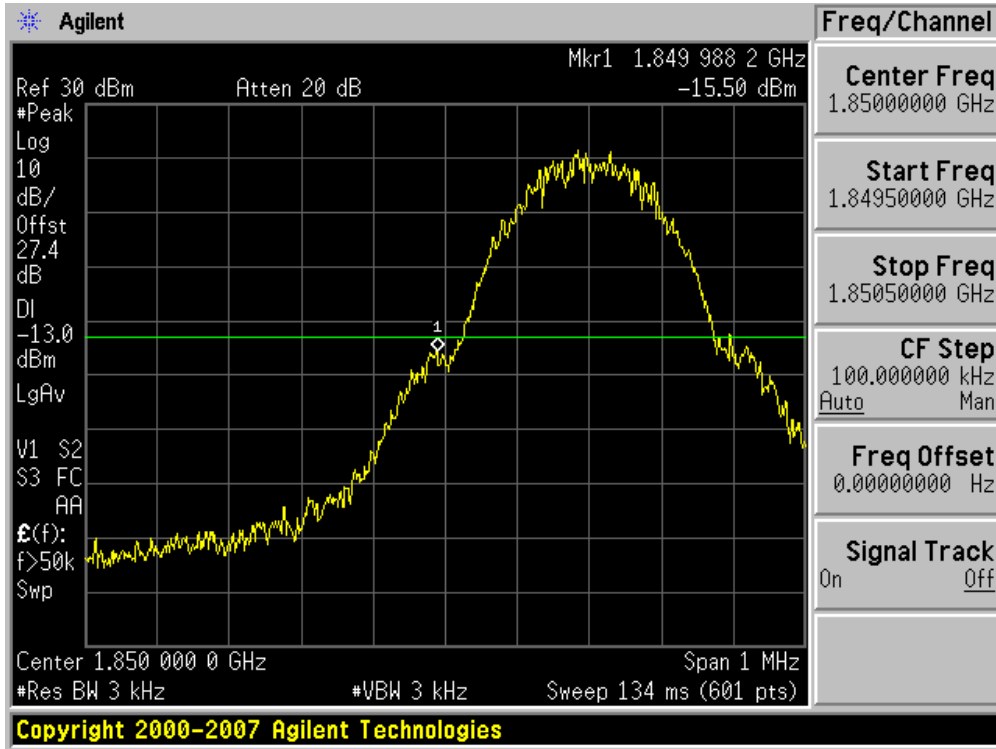

■ GSM1900 MODE (810 CH.) Block Edge

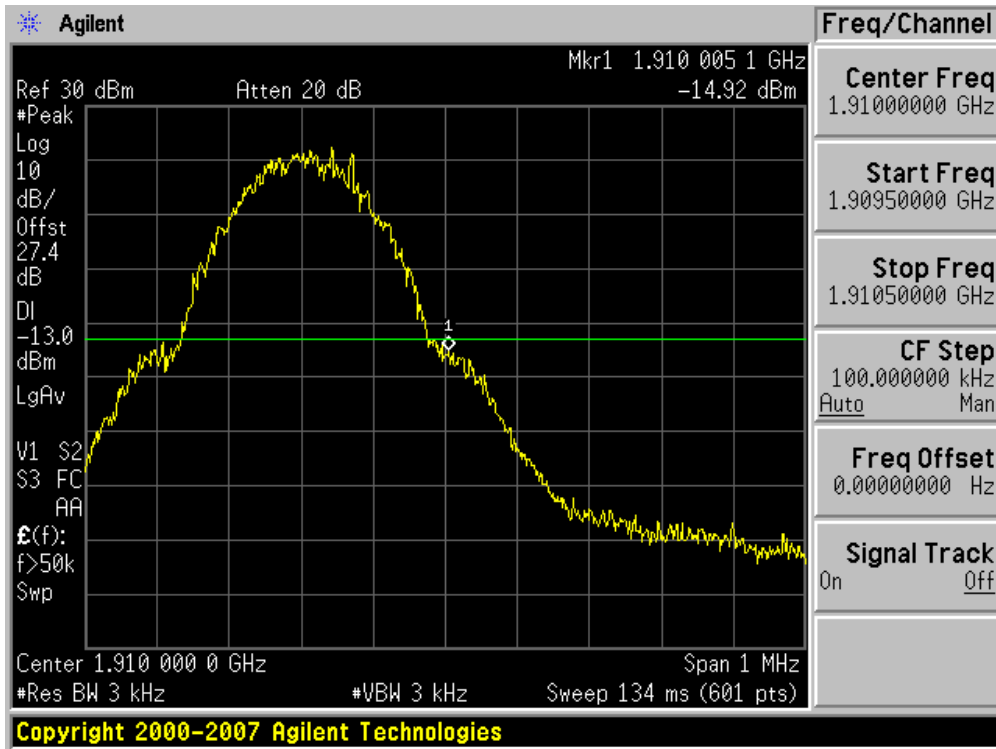

■ GSM1900 EDGE MODE (512 CH.) Block Edge

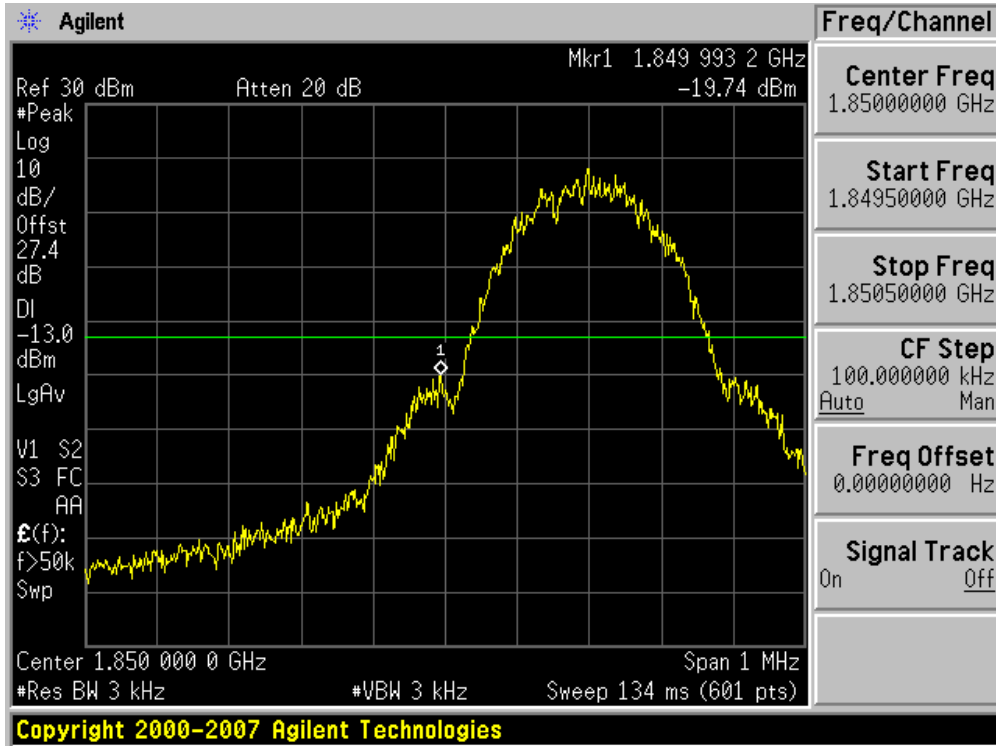

■ GSM1900 EDGE MODE (810 CH.) Block Edge

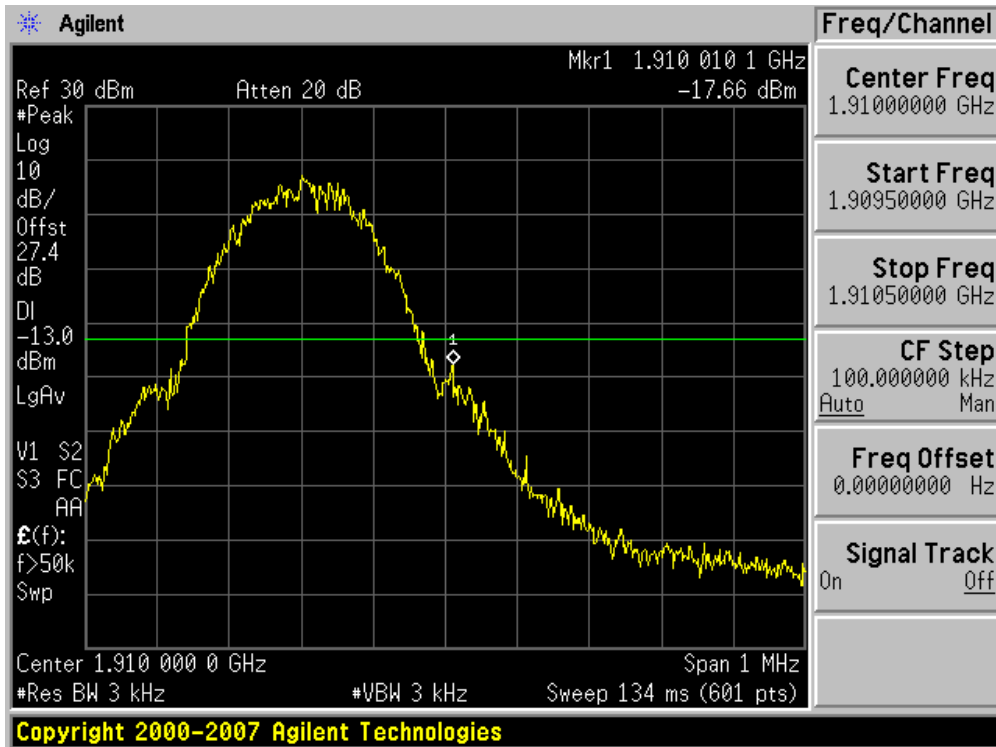

■ WCDMA850 MODE (4132 CH.) Block Edge

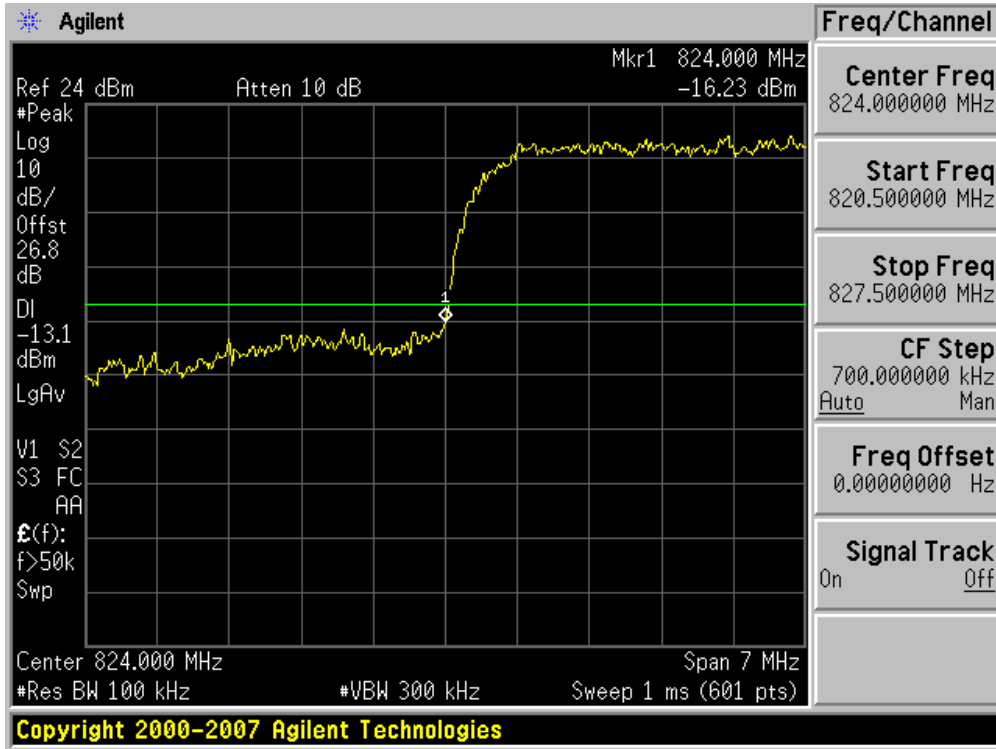

■ WCDMA850MODE (4233 CH.) Block Edge

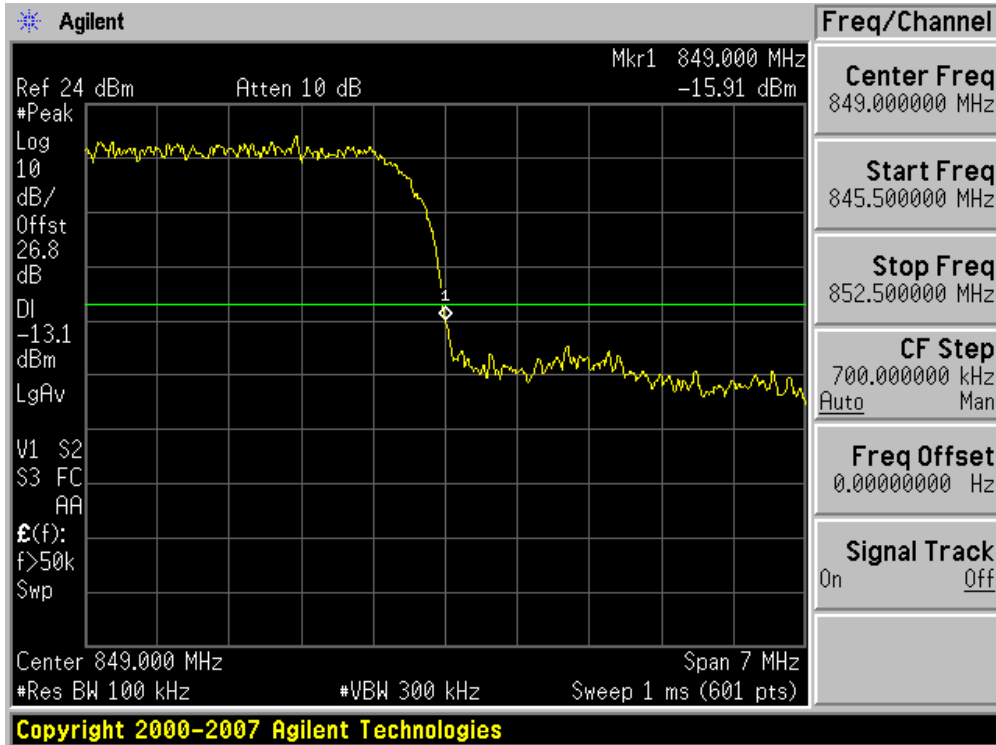

FCC CERTIFICATION REPORT

Test Report No. HCT-RF09-0313	Date of Issue: March 25, 2009	EUT Type: Dual-Band Dual-Mode GSM/WCDMA Phone with Bluetooth	FCC ID: JYCC790	Page 38 of 53
----------------------------------	----------------------------------	---	--------------------	---------------

■ WCDMA850 MODE (4132 CH.) – 4 MHz Span

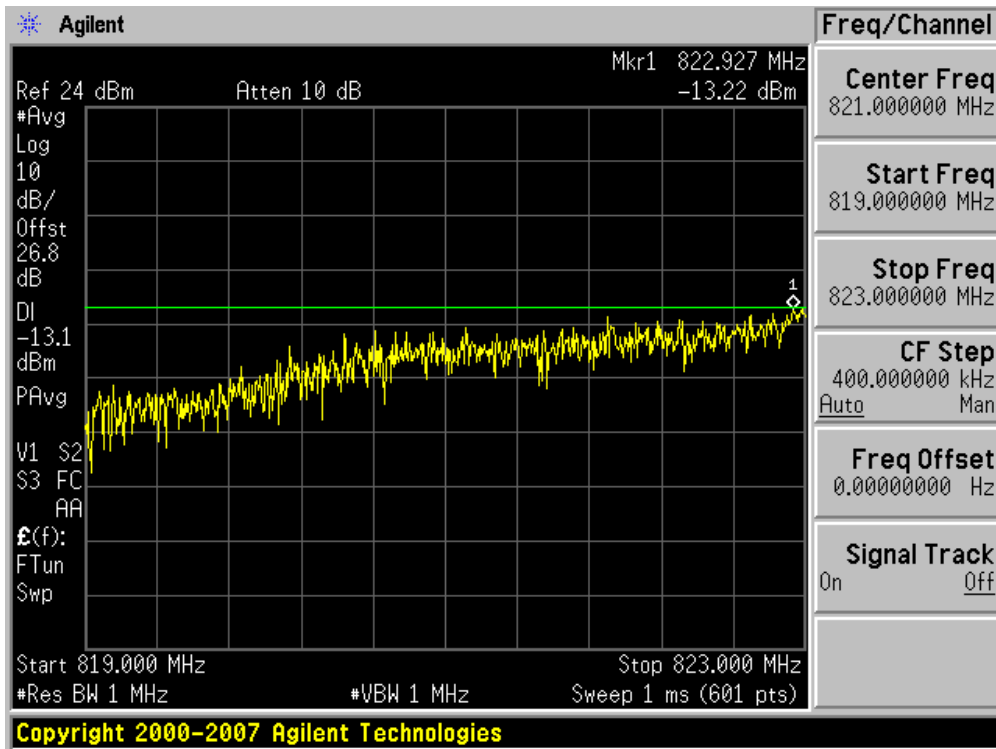

■ WCDMA850MODE (4233 CH.) – 4 MHz Span

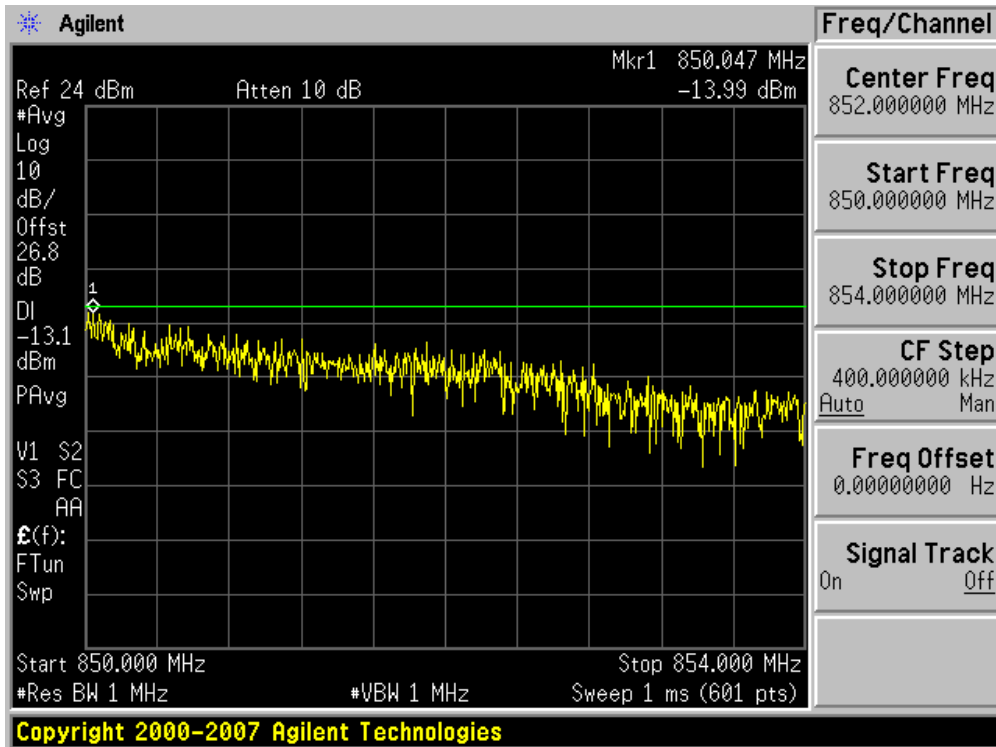

■ WCDMA1900 MODE (9262 CH.) Block Edge

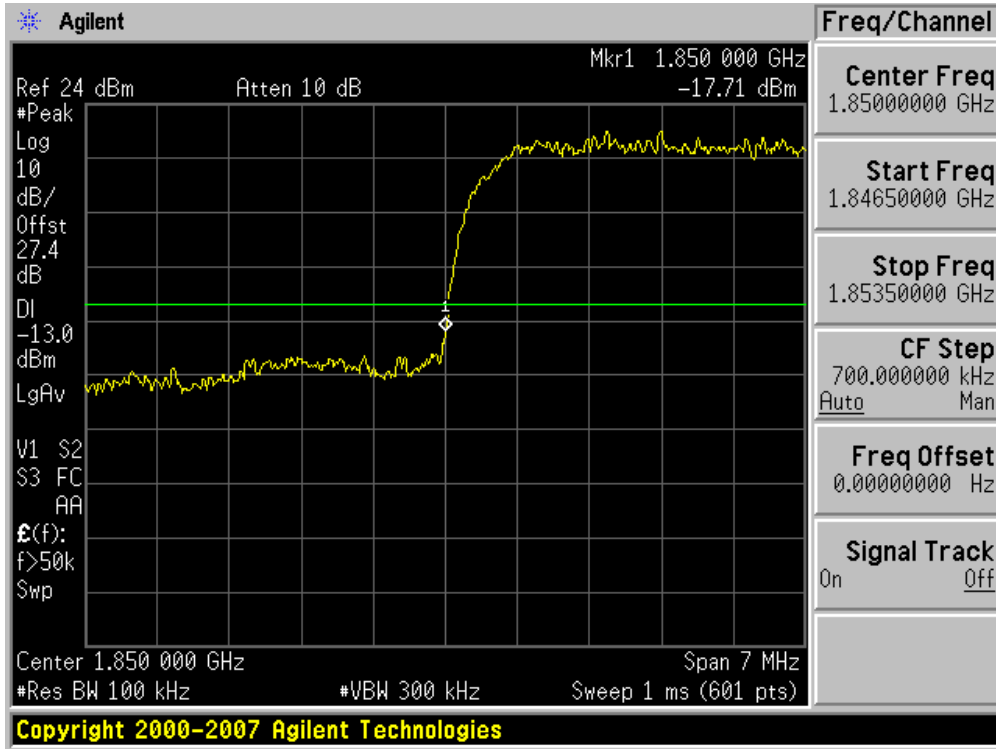

■ WCDMA1900 MODE (9538 CH.) Block Edge

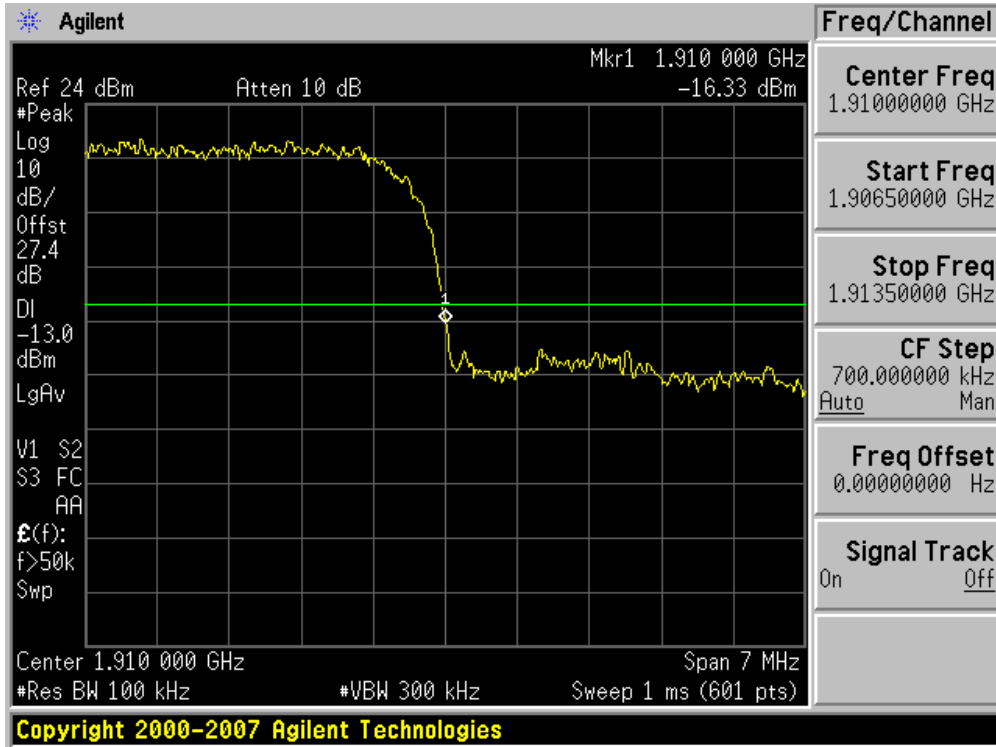

■ WCDMA1900 MODE (9262 CH.) – 4 MHz Span

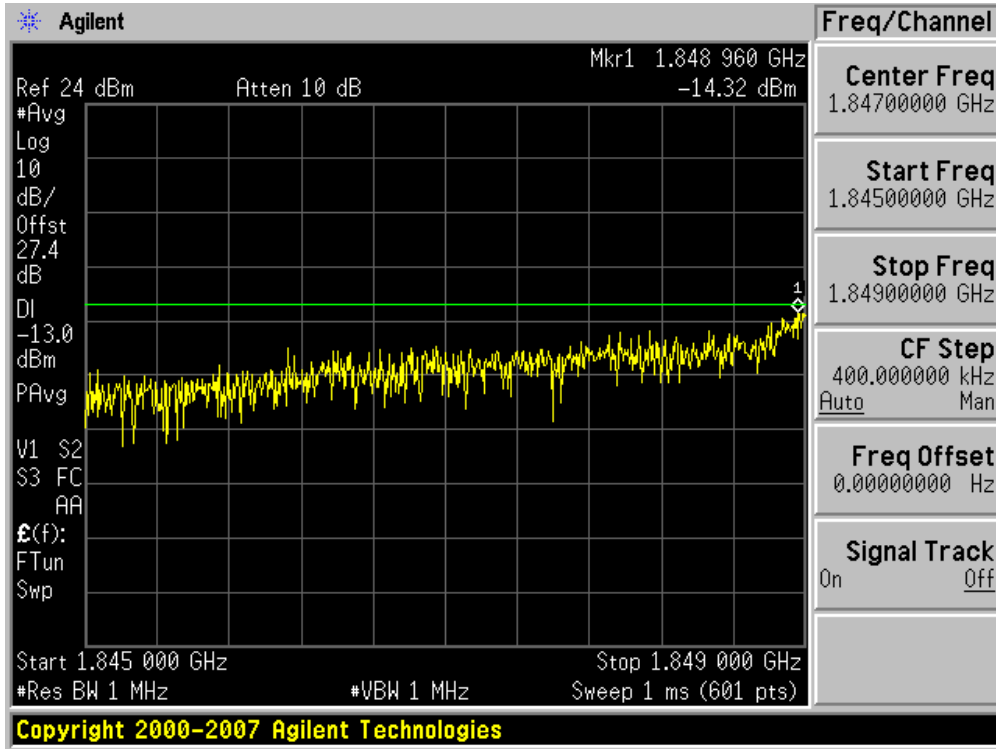

■ WCDMA1900 MODE (9538 CH.) – 4 MHz Span

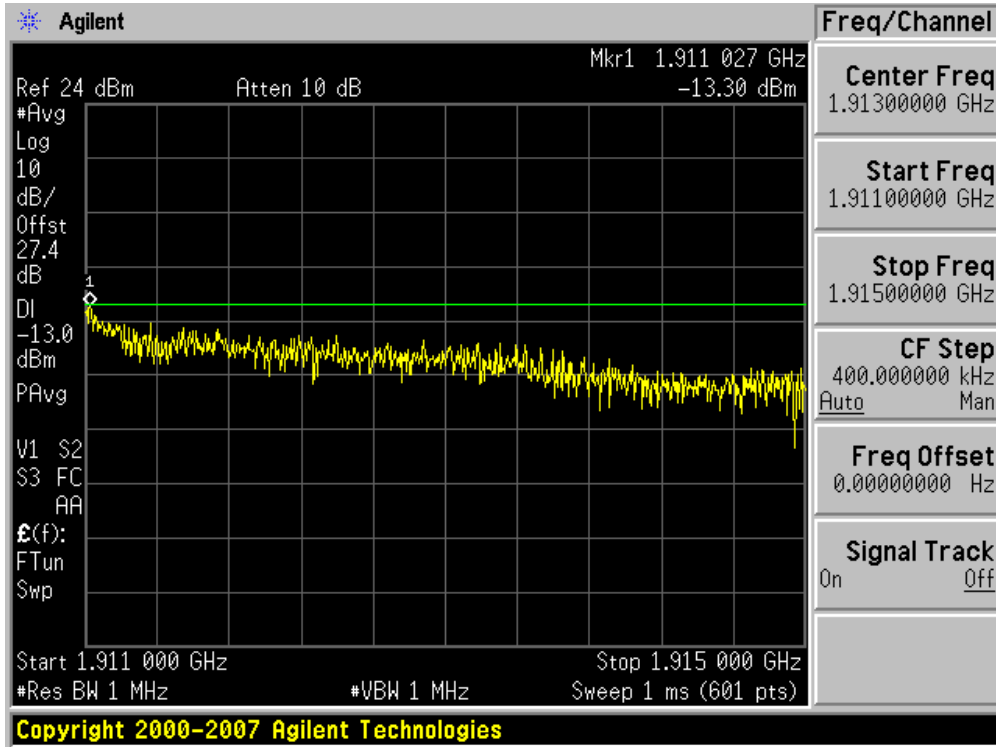

■ GSM850 MODE (128 CH.) Conducted Spurious Emissions1

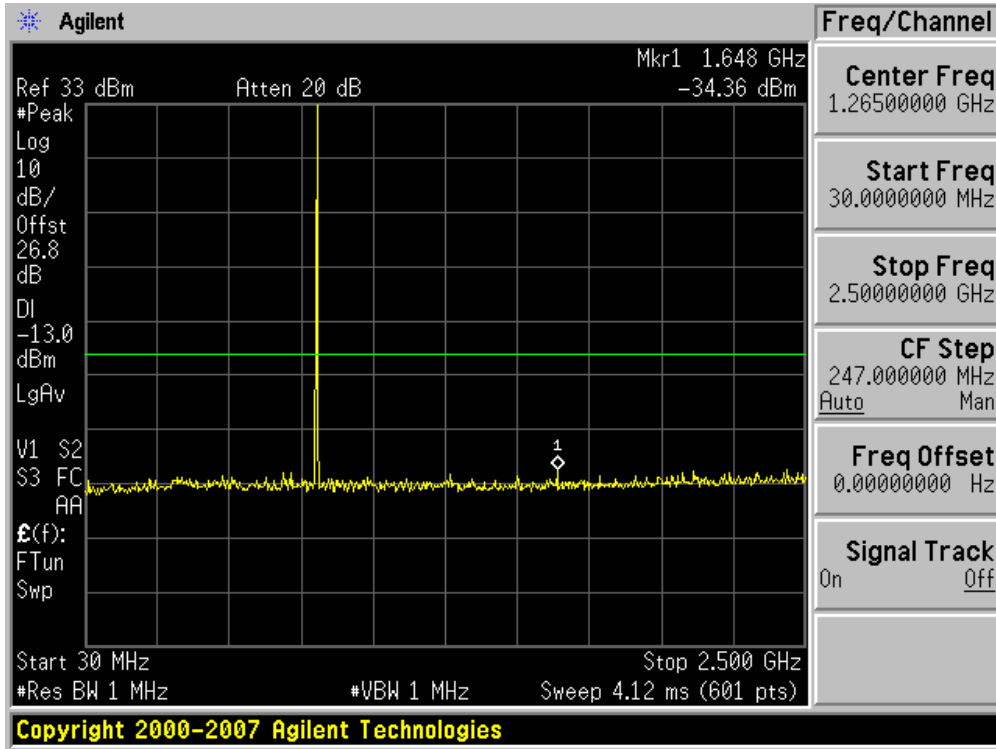

■ GSM850 MODE (128 CH.) Conducted Spurious Emissions2

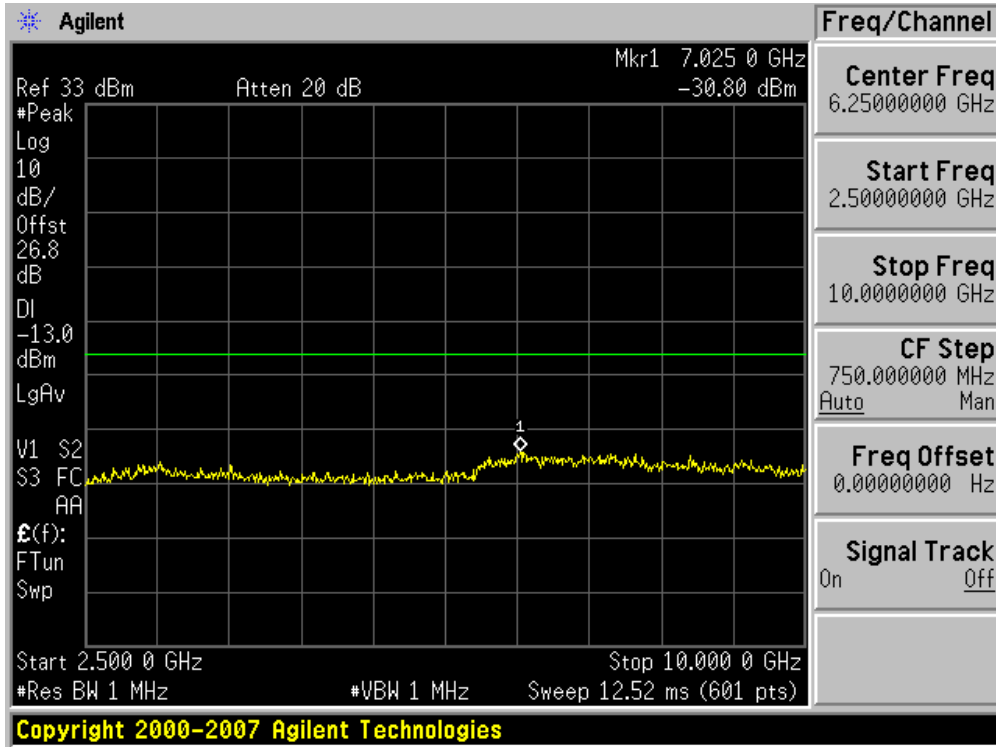



■ GSM850 MODE (190 CH.) Conducted Spurious Emissions1

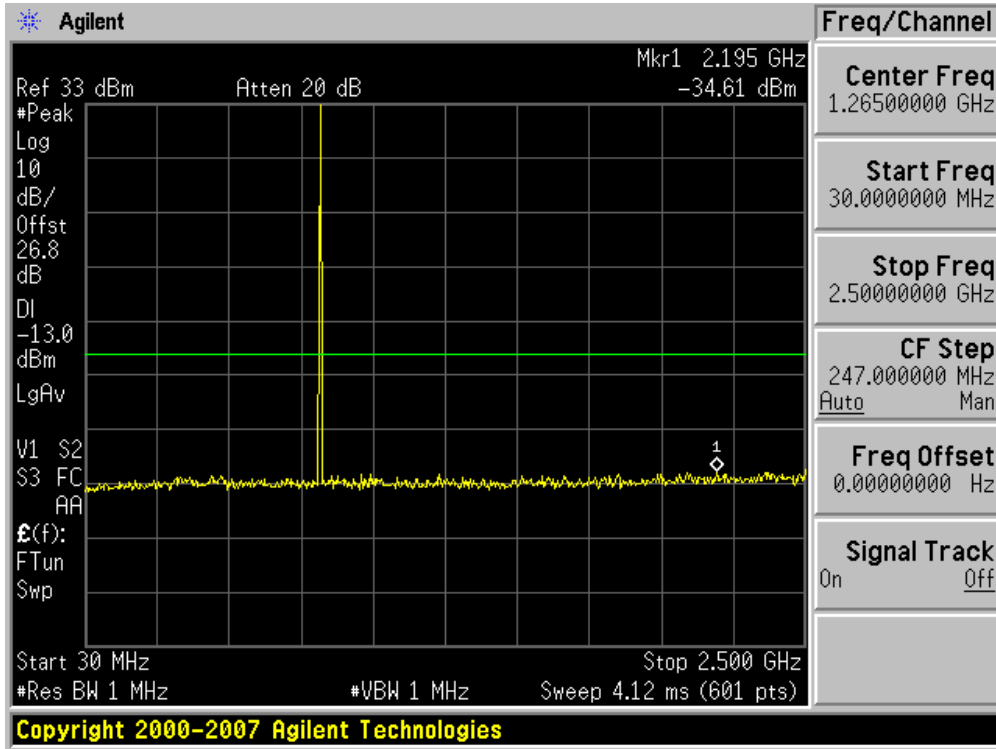

■ GSM850 MODE (190 CH.) Conducted Spurious Emissions2

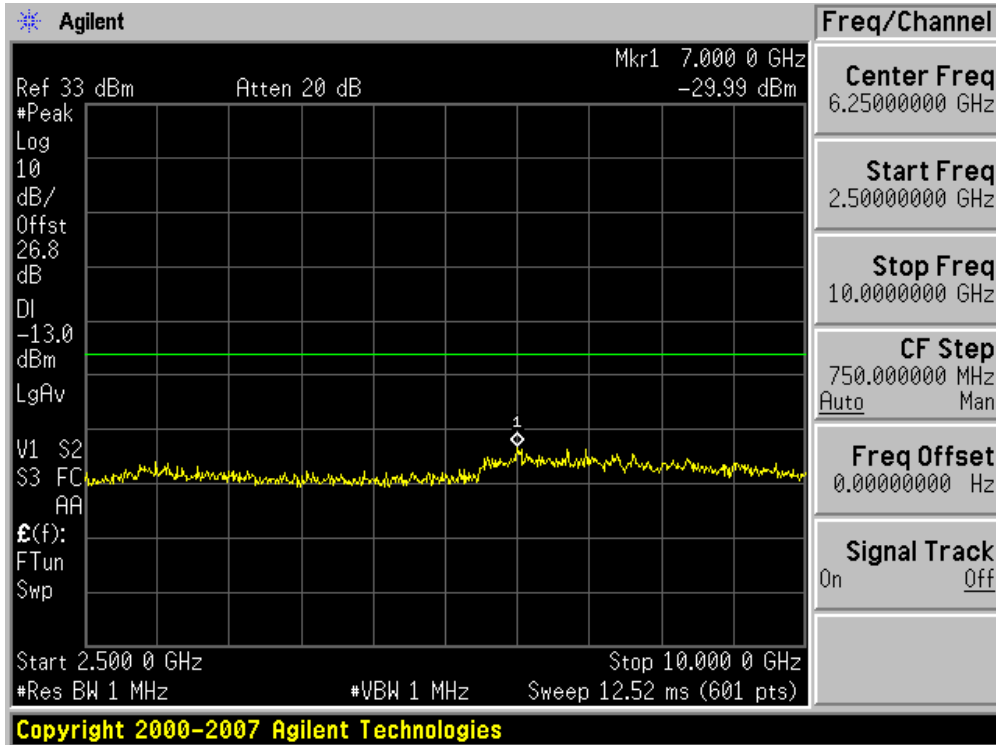

■ GSM850 MODE (251 CH.) Conducted Spurious Emissions1

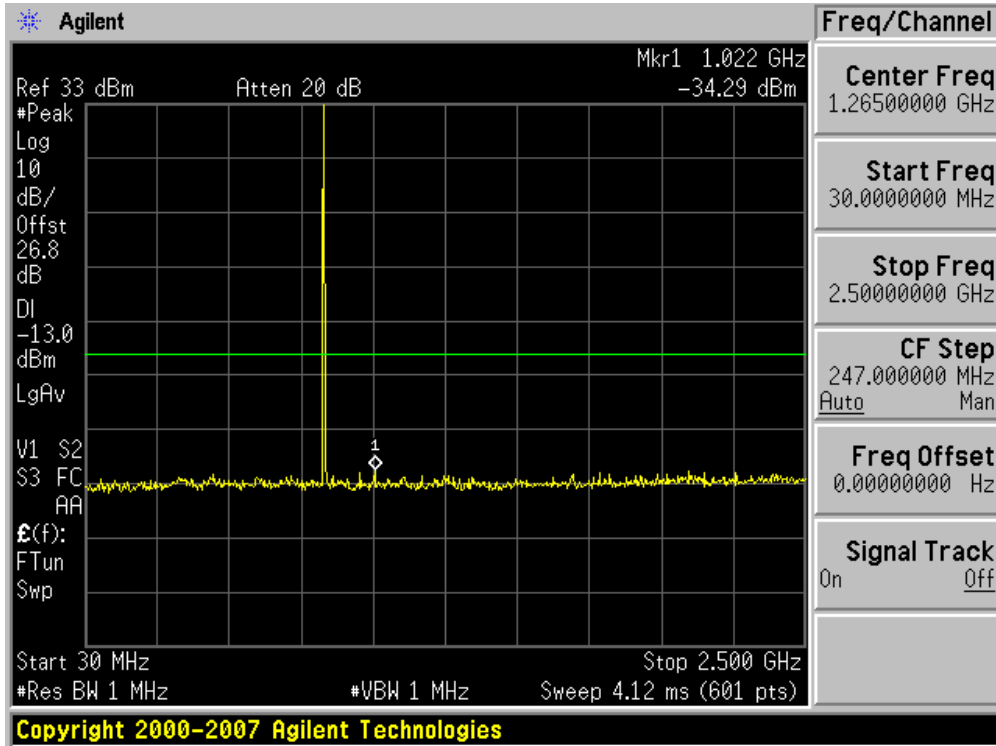

■ GSM850 MODE (251 CH.) Conducted Spurious Emissions2

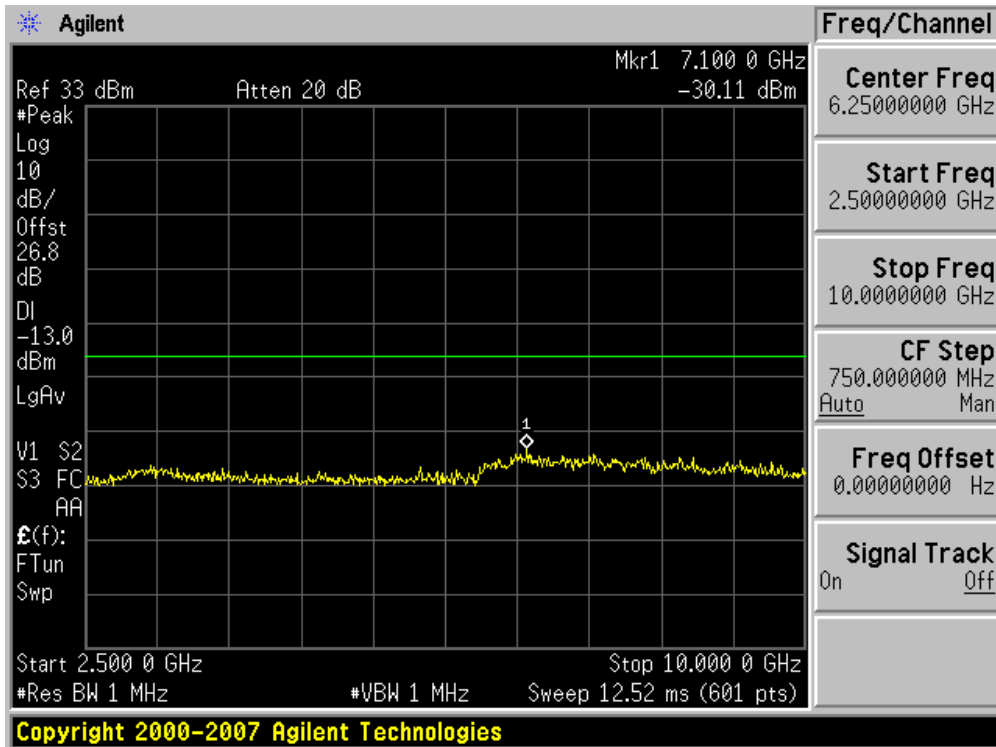

■ GSM1900 MODE (512 CH.) Conducted Spurious Emissions1

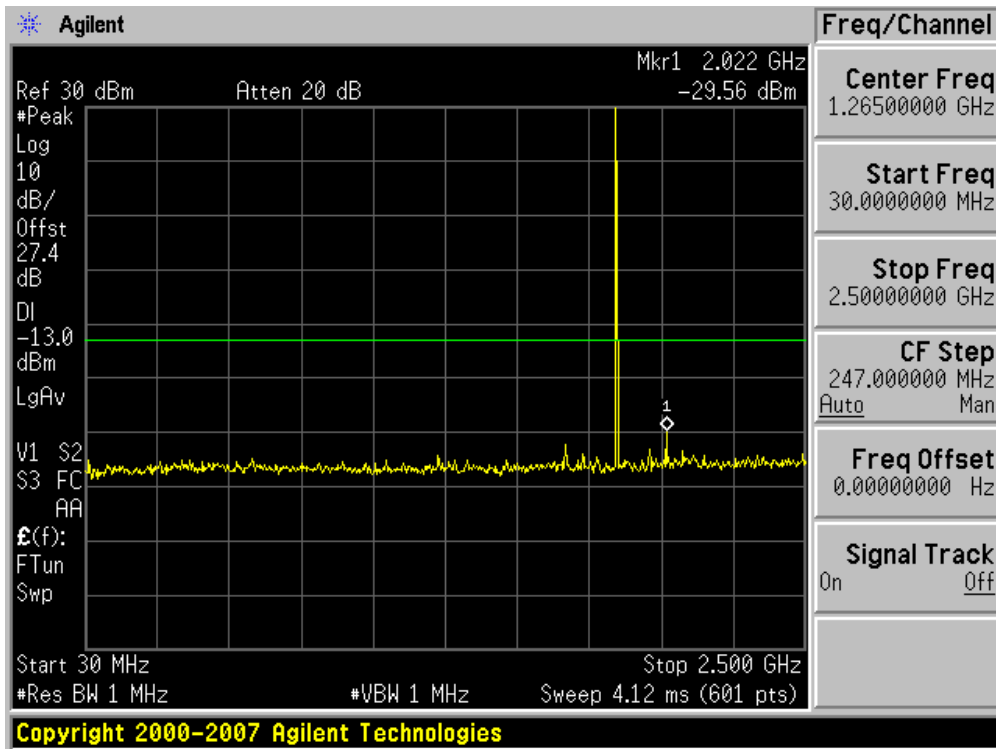

■ GSM1900 MODE (512 CH.) Conducted Spurious Emissions2

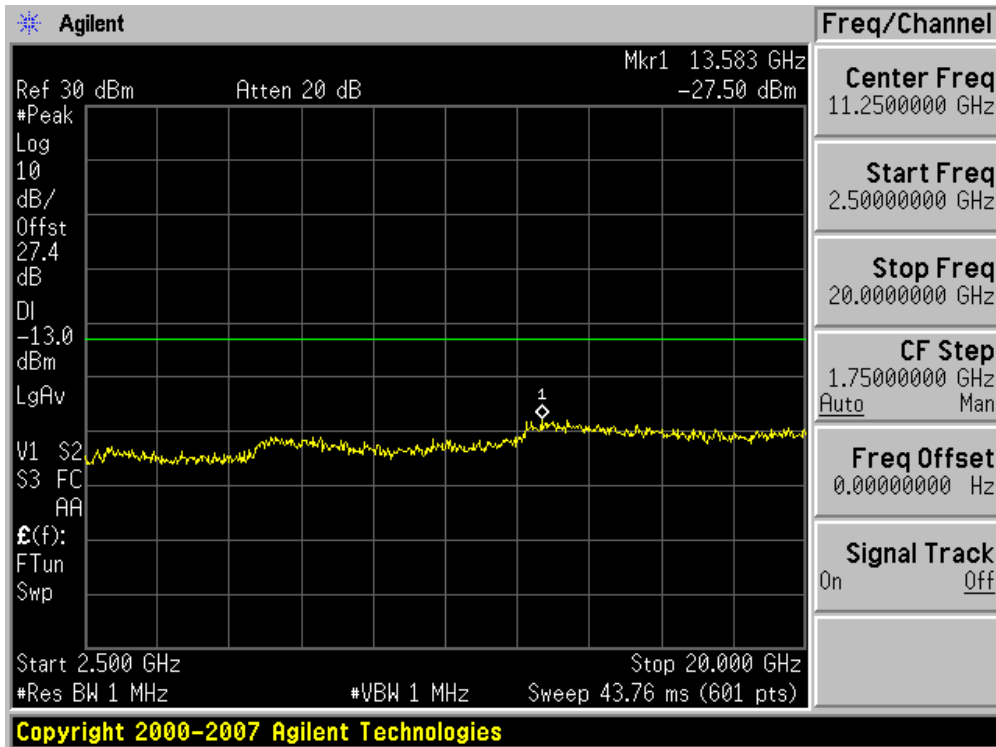

FCC CERTIFICATION REPORT

Test Report No. HCT-RF09-0313	Date of Issue: March 25, 2009	EUT Type: Dual-Band Dual-Mode GSM/WCDMA Phone with Bluetooth	FCC ID: JYCC790	Page 45 of 53
----------------------------------	----------------------------------	---	--------------------	---------------

■ GSM1900 MODE (661 CH.) Conducted Spurious Emissions1

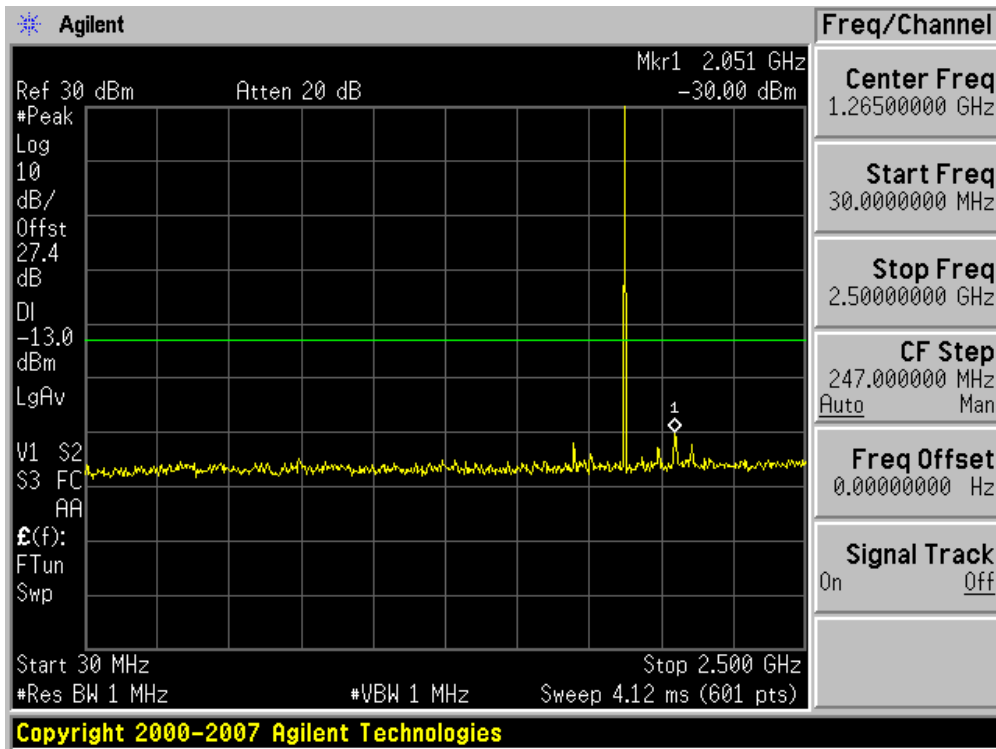

■ GSM1900 MODE (661 CH.) Conducted Spurious Emissions2

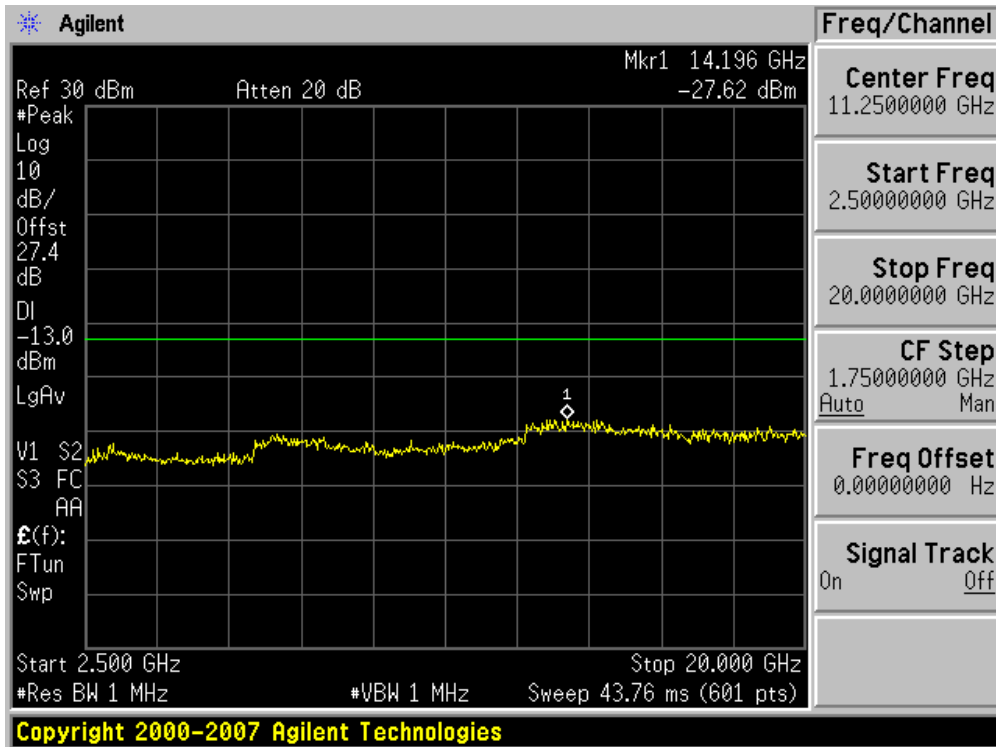

FCC CERTIFICATION REPORT

■ GSM1900 MODE (810 CH.) Conducted Spurious Emissions1

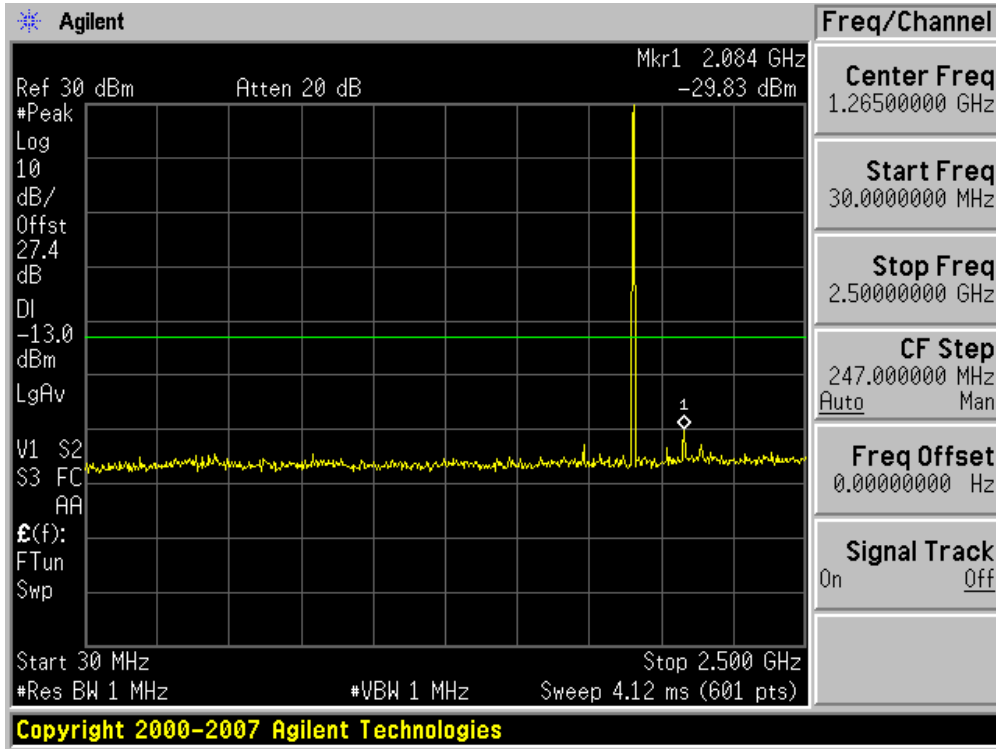

■ GSM1900 MODE (810 CH.) Conducted Spurious Emissions2

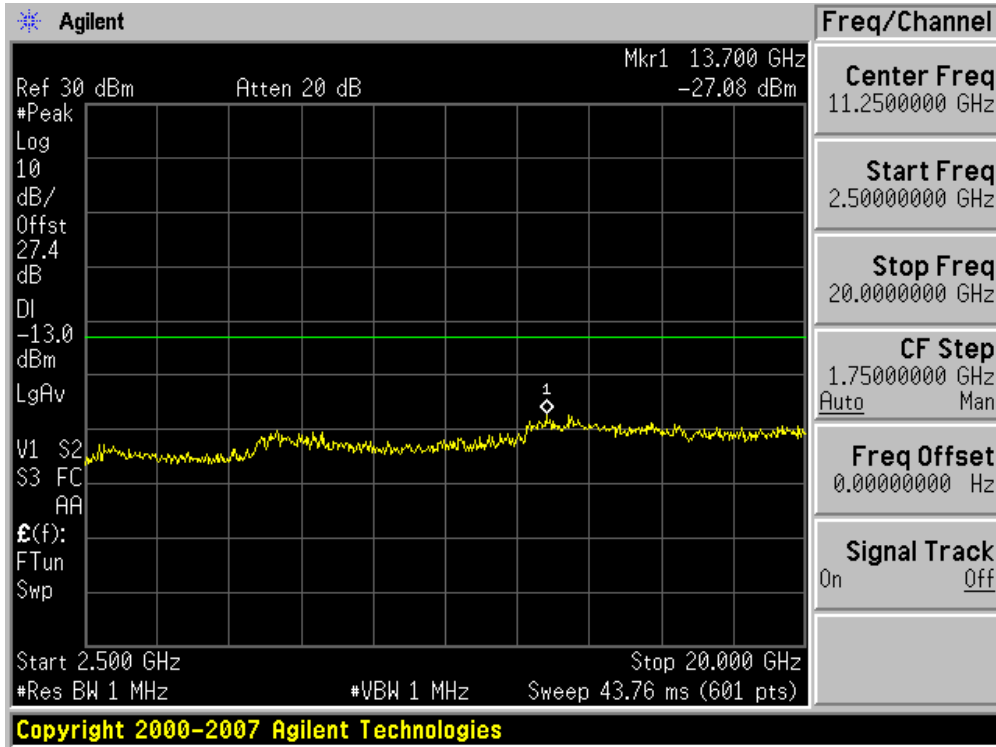

■ WCDMA850 MODE (4132 CH.) Conducted Spurious Emissions1

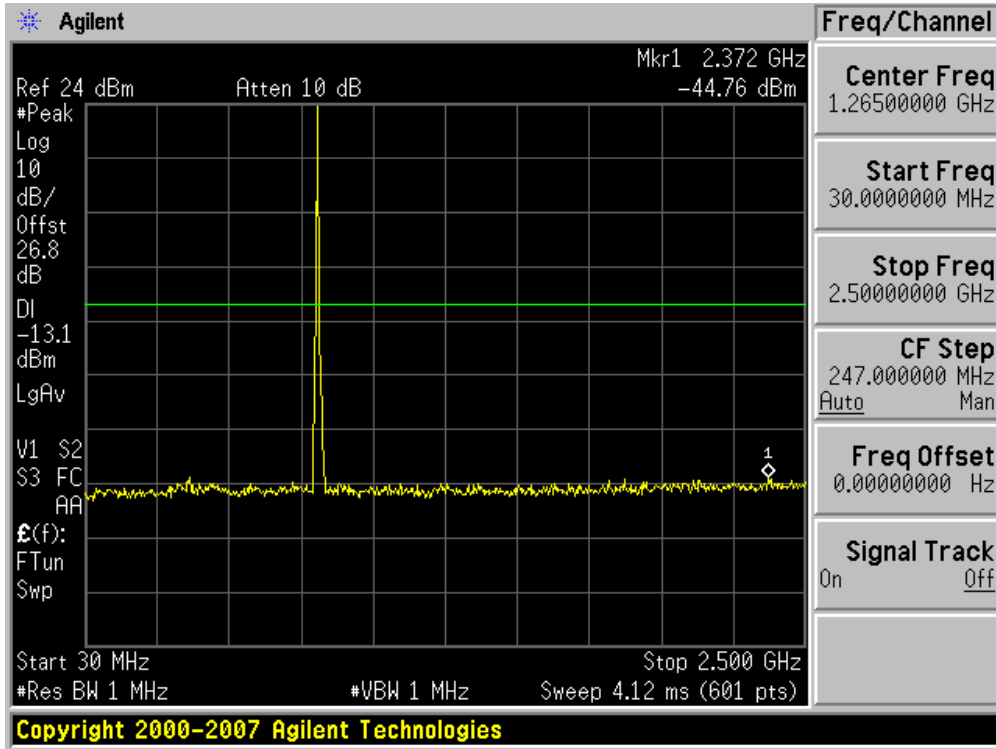

■ WCDMA850 MODE (4132 CH.) Conducted Spurious Emissions2

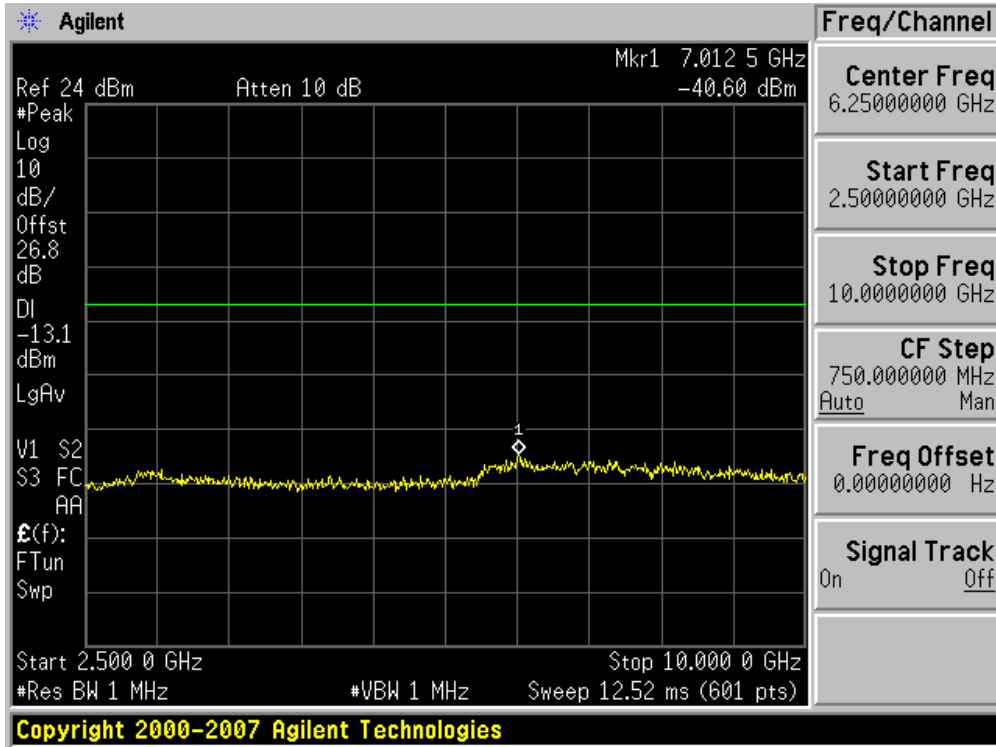

■ WCDMA850 MODE (4183 CH.) Conducted Spurious Emissions1

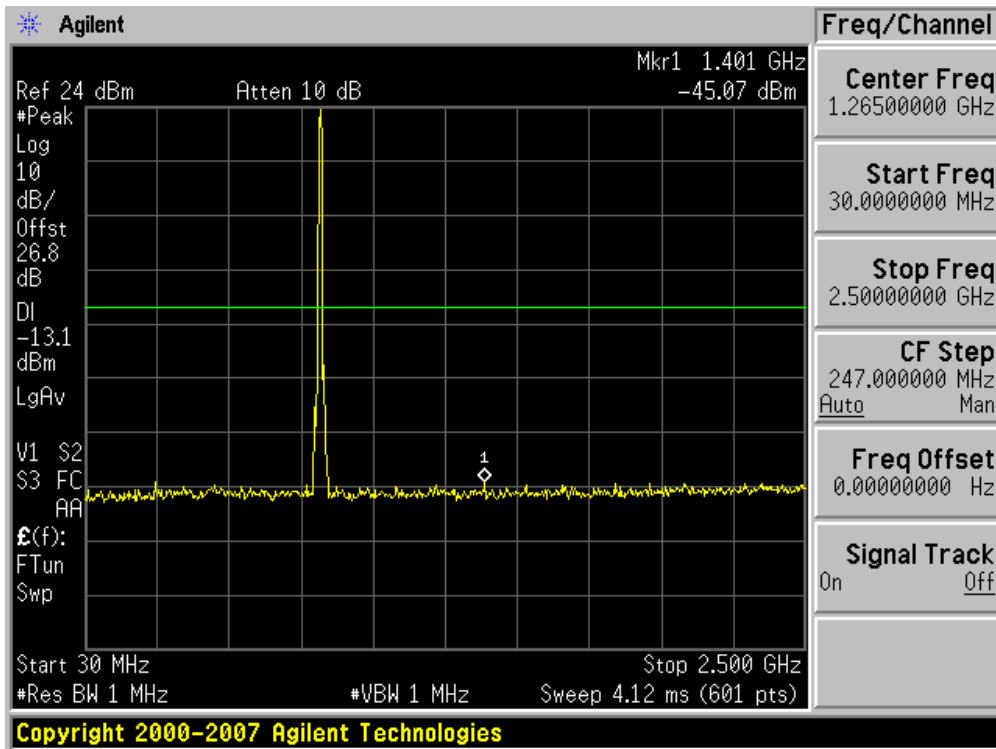

■ WCDMA850 MODE (4183 CH.) Conducted Spurious Emissions2

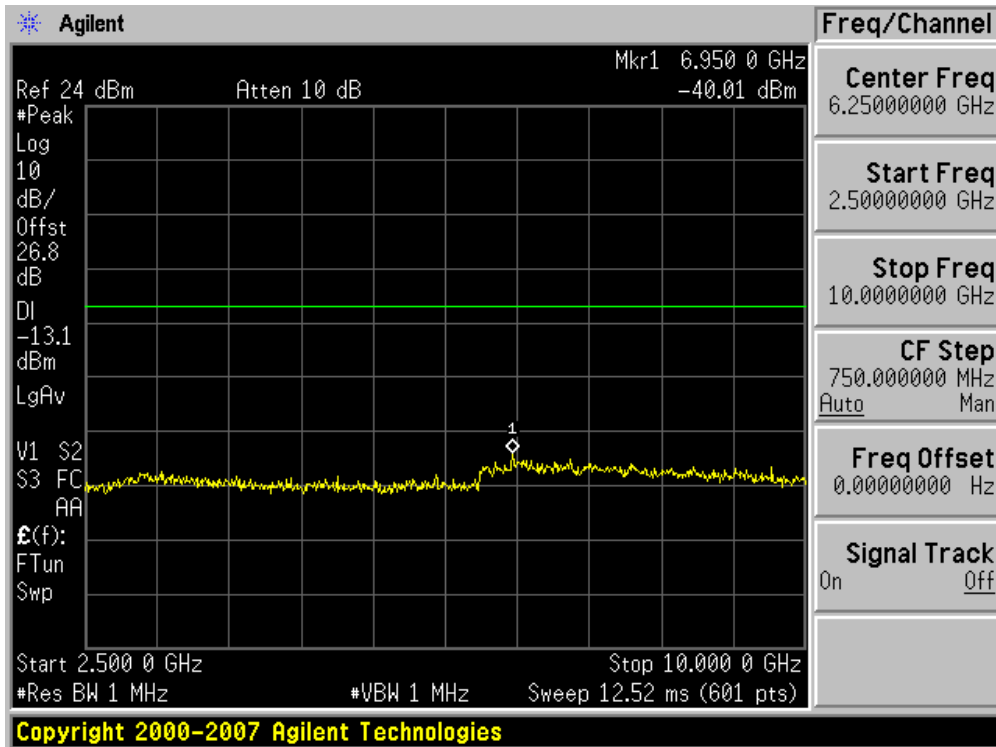

■ WCDMA850MODE (4233 CH.) Conducted Spurious Emissions1

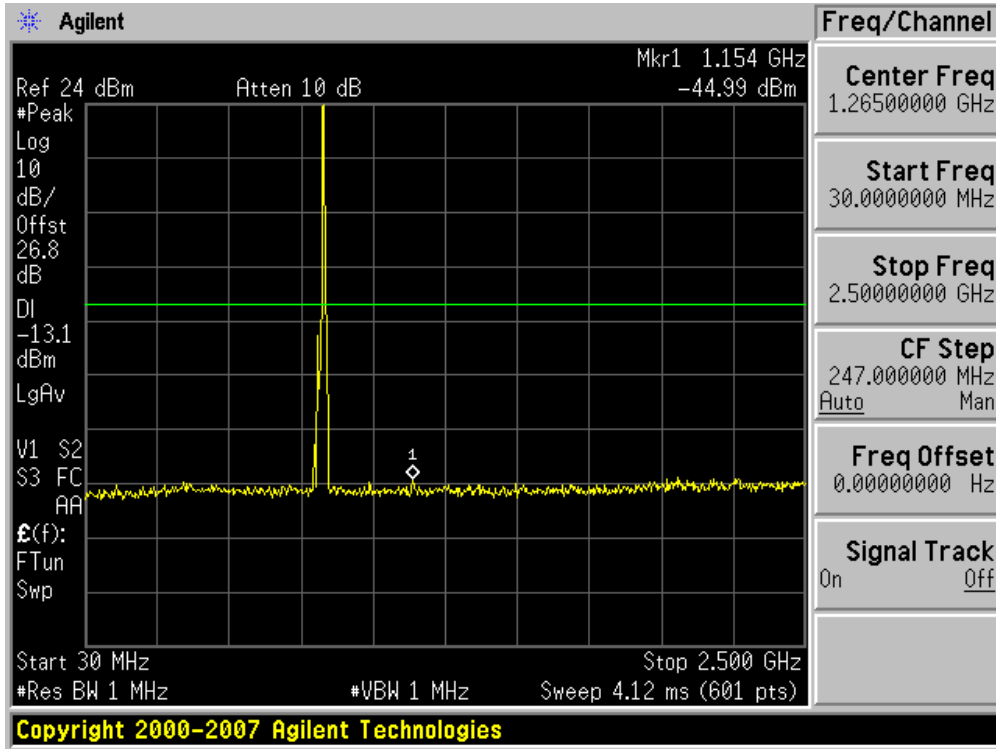

■ WCDMA850MODE (4233 CH.) Conducted Spurious Emissions2

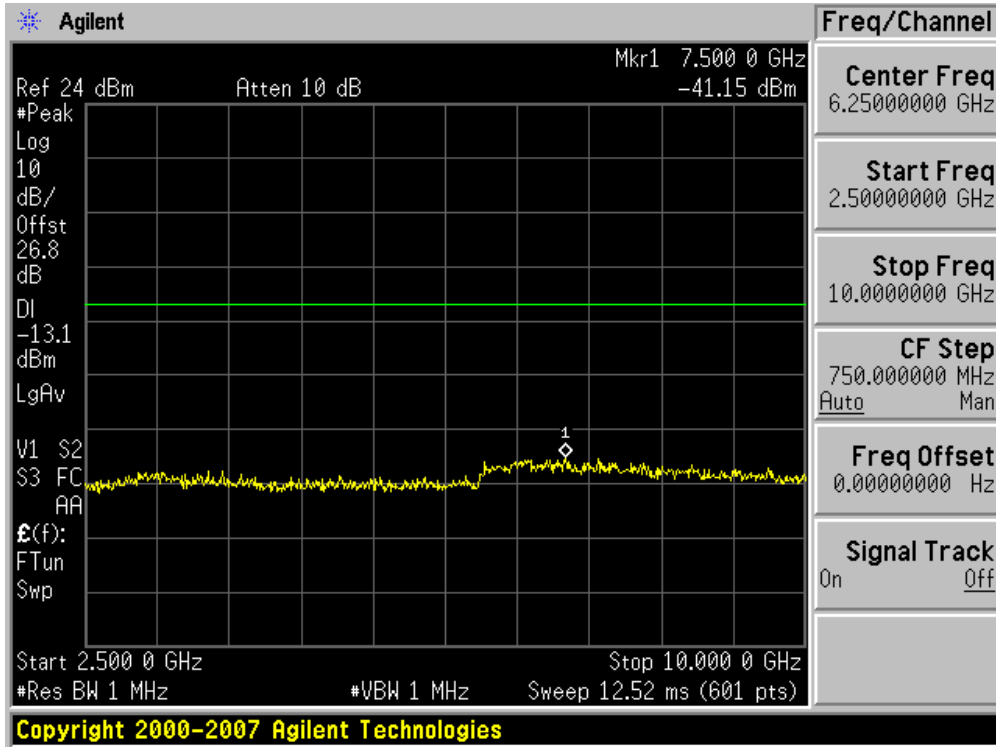

■ WCDMA1900 MODE (9262 CH.) Conducted Spurious Emissions1

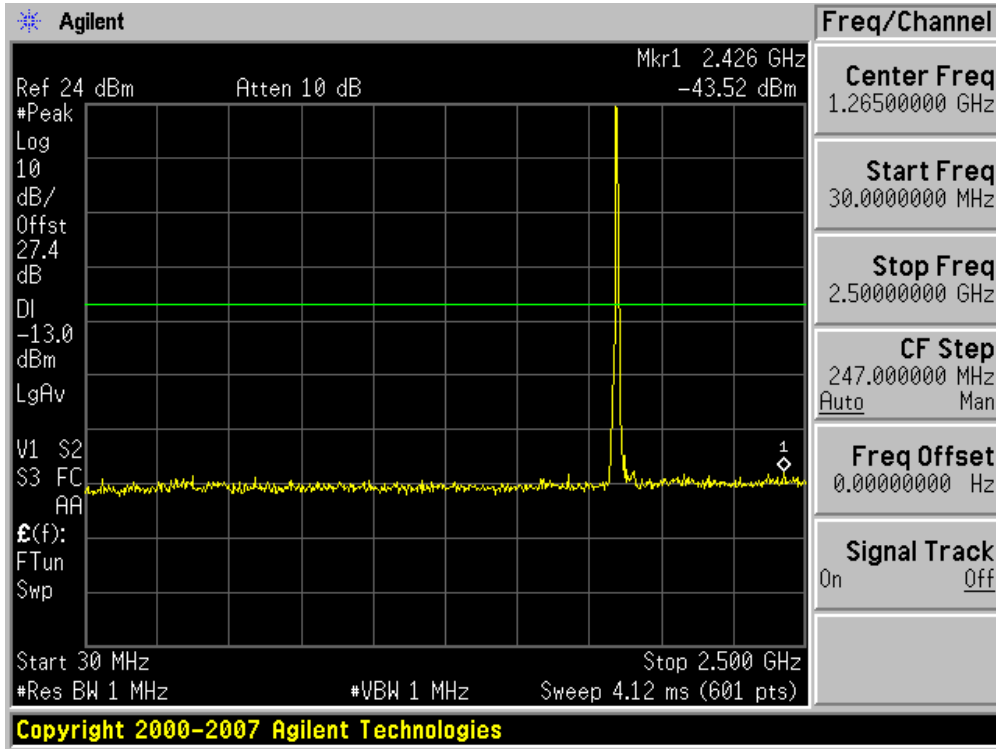

■ WCDMA1900 MODE (9262 CH.) Conducted Spurious Emissions2

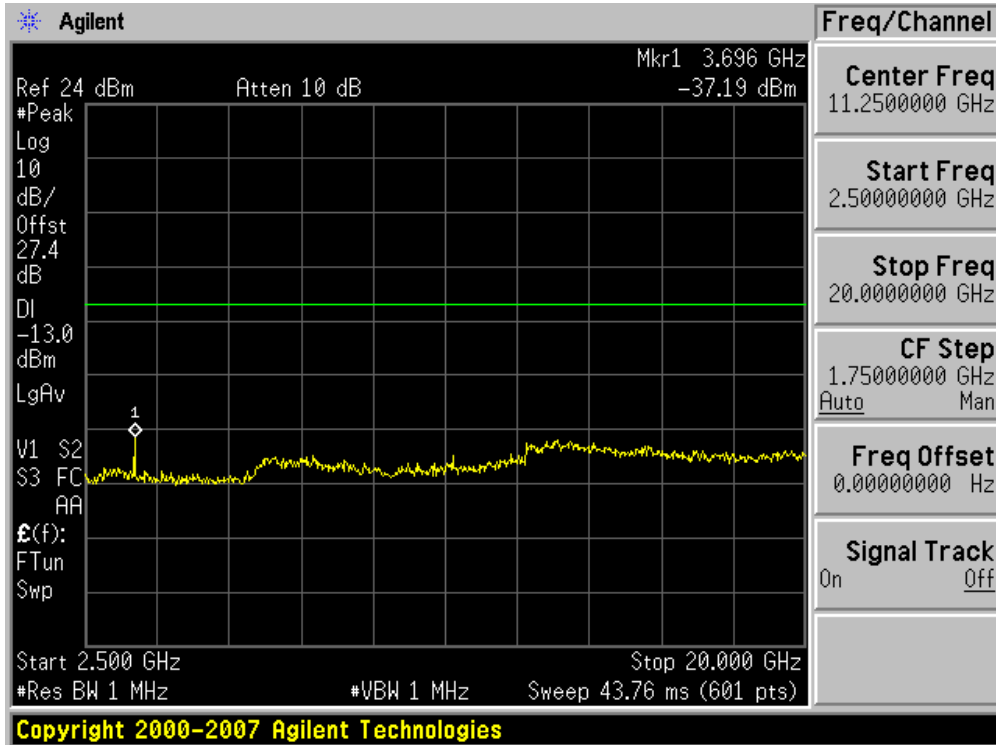

FCC CERTIFICATION REPORT

■ WCDMA1900 MODE (9400 CH.) Conducted Spurious Emissions1

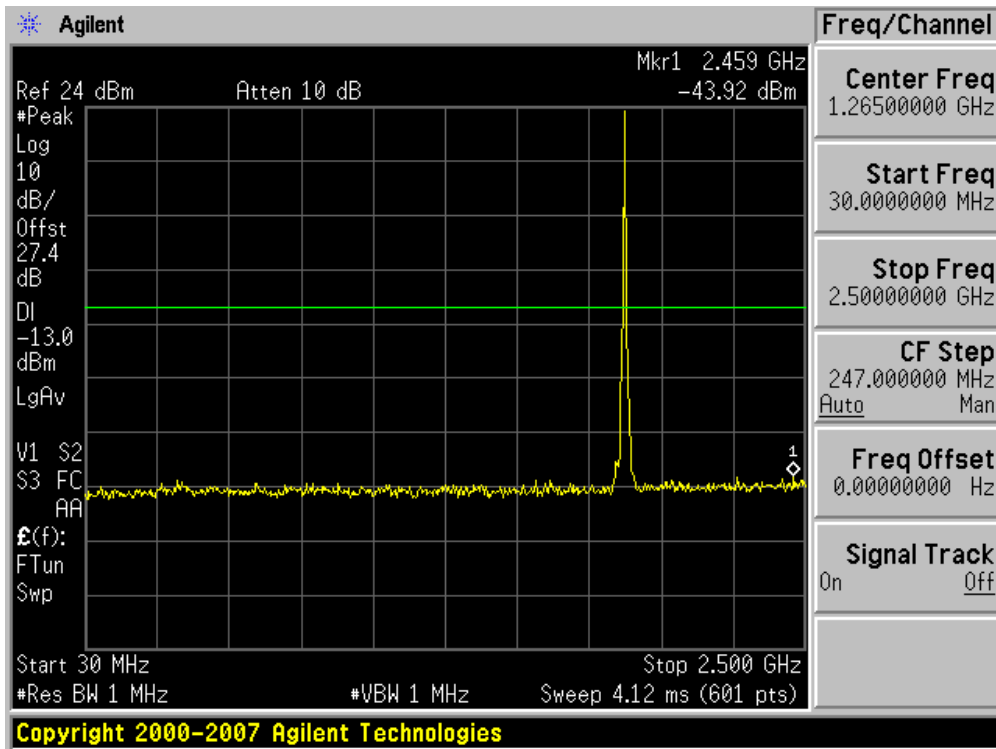

■ WCDMA1900 MODE (9400 CH.) Conducted Spurious Emissions2

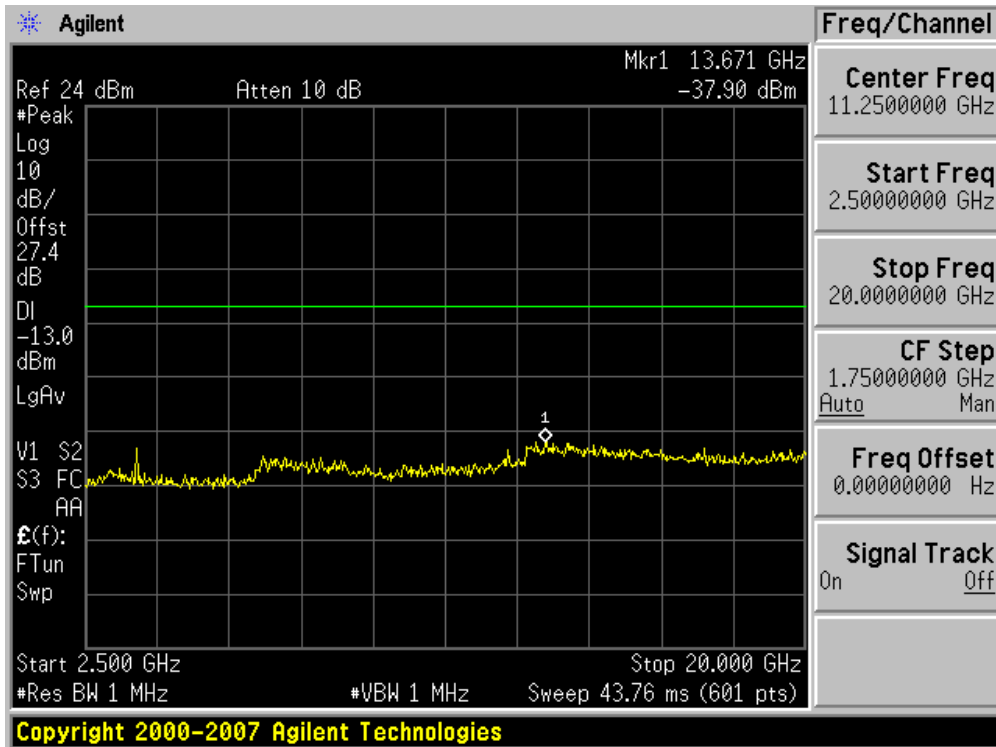

■ WCDMA1900 MODE (9538 CH.) Conducted Spurious Emissions1

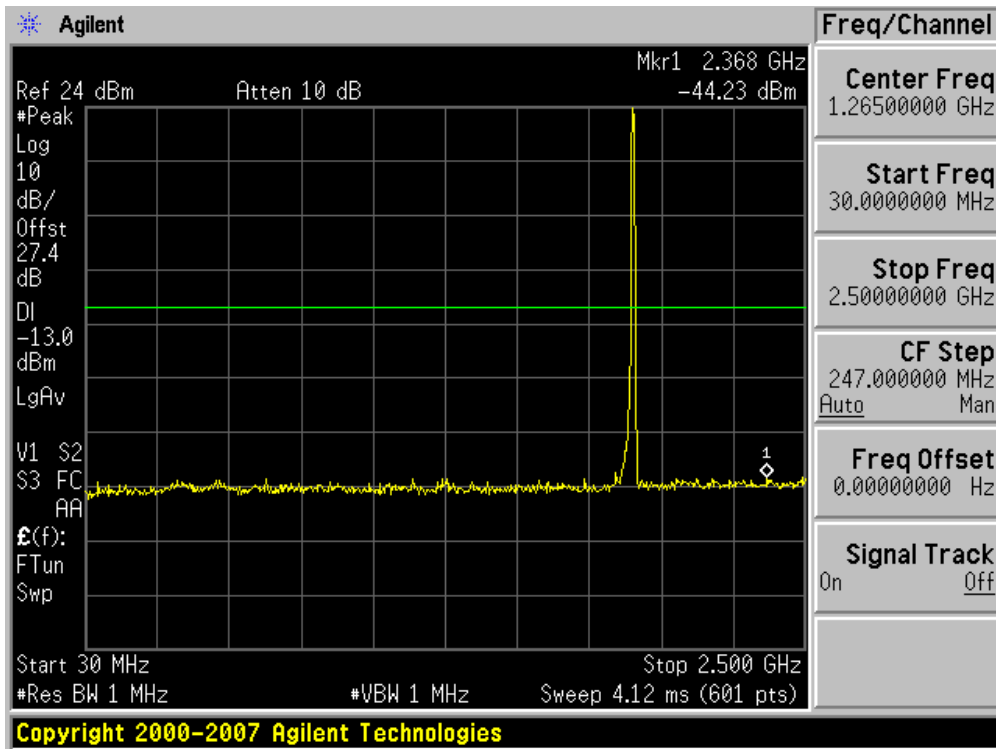

■ WCDMA1900 MODE (9538 CH.) Conducted Spurious Emissions2

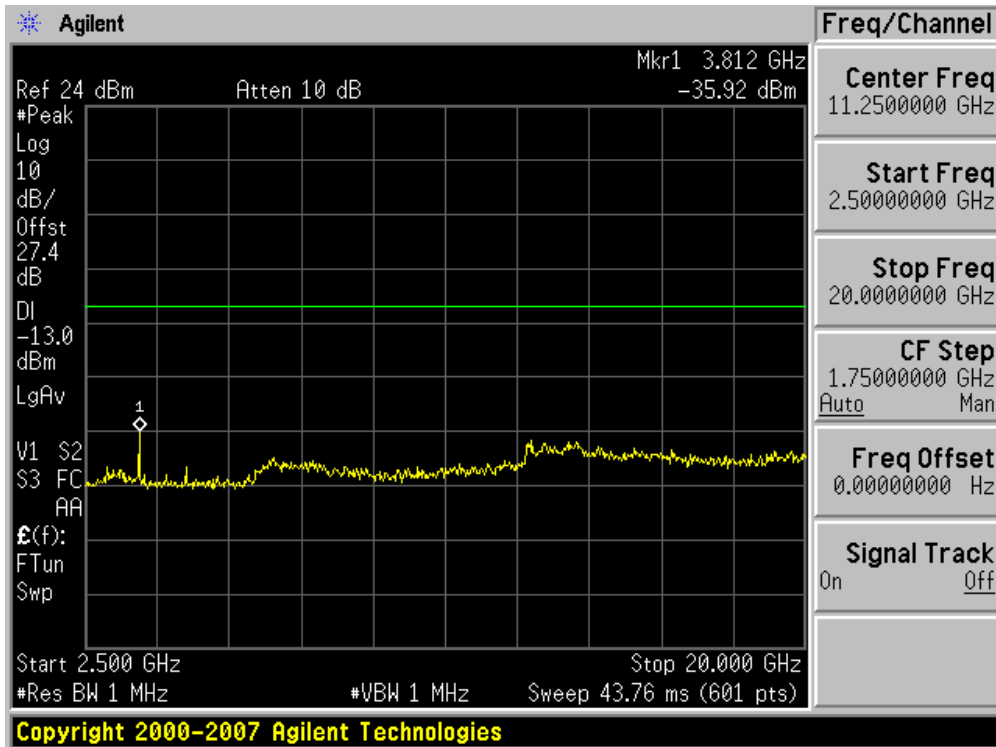

FCC CERTIFICATION REPORT