

## **APPENDIX C (DIPOLE VALIDATION)**

---

Test Laboratory: HCT CO., LTD.  
 Ambient Temperature: 21.5 °C  
 Test Date: June 5, 2011

**DUT: HAC-Dipole 835 MHz; Type: D835V3; Serial:1024**

Communication System: CW; Frequency: 835 MHz; Duty Cycle: 1:1  
 Medium parameters used:  $\sigma = 0$  mho/m,  $\epsilon_r = 1$ ;  $\rho = 1000$  kg/m<sup>3</sup>  
 Phantom section: E Dipole Section ; Measurement SW: DASY4, V4.7 Build 71; Postprocessing SW: SEMCAD, V1.8 Build 184

DASY4 Configuration:  
 - Probe: ER3DV6R - SN2242; ConvF(1, 1, 1); Calibrated: 2010-09-20  
 - Sensor-Surface: (Fix Surface)  
 - Electronics: DAE4 Sn869; Calibrated: 2010-09-21  
 - Phantom: HAC Test Arch; Type: SD HAC P01 BA

**E Scan 10mm above CD 835 MHz/Hearing Aid Compatibility Test (41x361x1):** Measurement grid: dx=5mm, dy=5mm  
 Maximum value of peak Total field = 171.0 V/m  
 Probe Modulation Factor = 1.00  
 Device Reference Point: 0.000, 0.000, 354.7 mm  
 Reference Value = 138.3 V/m; Power Drift = 0.002 dB  
**Hearing Aid Near-Field Category: M4 (AWF 0 dB)**

Peak E-field in V/m

Grid 1 169.7 M4	Grid 2 171.0 M4	Grid 3 164.4 M4
Grid 4 94.9 M4	Grid 5 95.2 M4	Grid 6 92.3 M4
Grid 7 162.9 M4	Grid 8 163.2 M4	Grid 9 157.5 M4

**Cursor:**  
 Total = 171.0 V/m  
 E Category: M4  
 Location: 1.5, -79.5, 365.8 mm

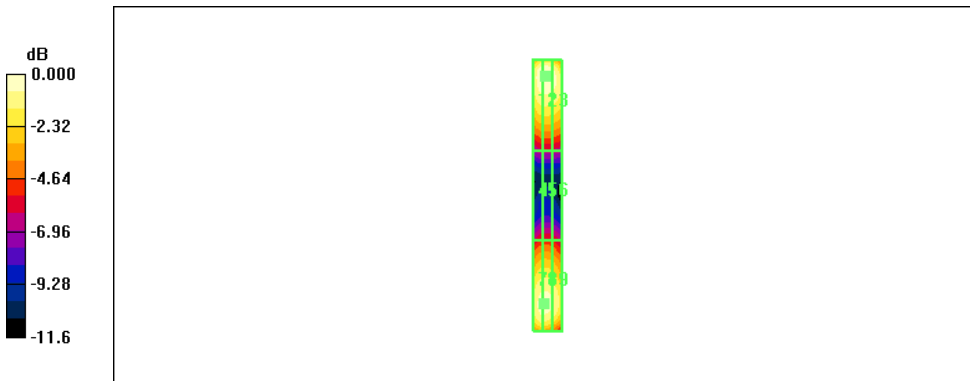

0 dB = 171.0V/m

Test Laboratory: HCT CO., LTD.  
 Ambient Temperature: 21.5 °C  
 Test Date: June 5, 2011

**DUT: HAC Dipole 1880 MHz; Type: CD1880V3; Serial:1019**

Communication System: CW; Frequency: 1880 MHz; Duty Cycle: 1:1  
 Medium parameters used:  $\sigma = 0$  mho/m,  $\epsilon_r = 1$ ;  $\rho = 1000$  kg/m<sup>3</sup>  
 Phantom section: E Dipole Section ; Measurement SW: DASY4, V4.7 Build 71; Postprocessing SW: SEMCAD, V1.8 Build 184

DASY4 Configuration:  
 - Probe: ER3DV6R - SN2242; ConvF(1, 1, 1); Calibrated: 2010-09-20  
 - Sensor-Surface: (Fix Surface)  
 - Electronics: DAE4 Sn869; Calibrated: 2010-09-21  
 - Phantom: HAC Test Arch; Type: SD HAC P01 BA

**E Scan 10mm above CD 1880 MHz/Hearing Aid Compatibility Test (41x181x1):** Measurement grid: dx=5mm, dy=5mm  
 Maximum value of peak Total field = 142.3 V/m  
 Probe Modulation Factor = 1.00  
 Device Reference Point: 0.000, 0.000, 354.7 mm  
 Reference Value = 156.4 V/m; Power Drift = 0.014 dB  
**Hearing Aid Near-Field Category: M2 (AWF 0 dB)**

Peak E-field in V/m

Grid 1	Grid 2	Grid 3
139.9 M2	140.6 M2	134.0 M2
Grid 4	Grid 5	Grid 6
103.2 M3	105.3 M3	103.2 M3
Grid 7	Grid 8	Grid 9
141.0 M2	142.3 M2	138.5 M2

**Cursor:**

Total = 142.3 V/m  
 E Category: M2  
 Location: 0.5, 31, 365.8 mm

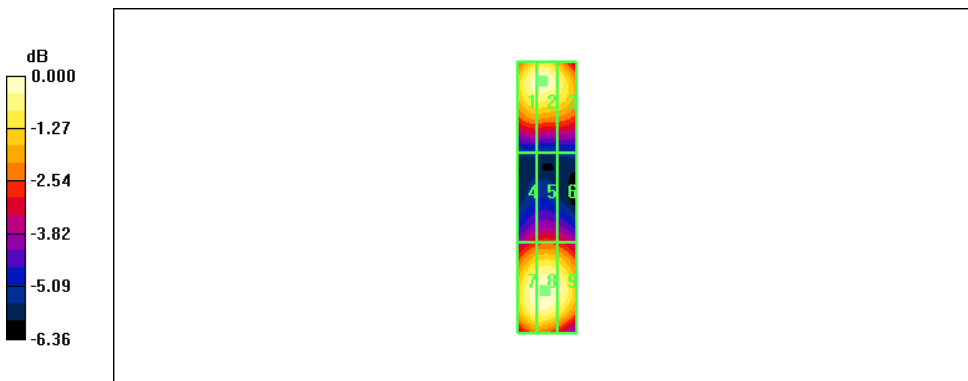

0 dB = 142.3V/m

Test Laboratory: HCT CO., LTD.  
 Ambient Temperature: 21.5 °C  
 Test Date: June 5, 2011

**DUT: HAC-Dipole 835 MHz; Type: D835V3; Serial:1024**

Communication System: CW; Frequency: 835 MHz; Duty Cycle: 1:1  
 Medium parameters used:  $\sigma = 0$  mho/m,  $\epsilon_r = 1$ ;  $\rho = 1$  kg/m<sup>3</sup>  
 Phantom section: H Dipole Section ; Measurement SW: DASY4, V4.7 Build 71; Postprocessing SW: SEMCAD, V1.8 Build 184

DASY4 Configuration:

- Probe: H3DV6 - SN6051; ; Calibrated: 2010-09-20
- Sensor-Surface: (Fix Surface)
- Electronics: DAE4 Sn869; Calibrated: 2010-09-21
- Phantom: HAC Test Arch; Type: SD HAC P01 BA

**H Scan 10mm above CD 835 MHz/Hearing Aid Compatibility Test (41x361x1):** Measurement grid: dx=5mm, dy=5mm

Maximum value of peak Total field = 0.458 A/m  
 Probe Modulation Factor = 1.00  
 Device Reference Point: 0.000, 0.000, 354.7 mm  
 Reference Value = 0.561 A/m; Power Drift = -0.078 dB  
**Hearing Aid Near-Field Category: M4 (AWF 0 dB)**

Peak H-field in A/m

Grid 1 0.364 M4	Grid 2 0.397 M4	Grid 3 0.391 M4
Grid 4 0.419 M4	Grid 5 0.458 M4	Grid 6 0.452 M4
Grid 7 0.370 M4	Grid 8 0.405 M4	Grid 9 0.399 M4

**Cursor:**

Total = 0.458 A/m  
 H Category: M4  
 Location: -1.5, 1, 366.6 mm

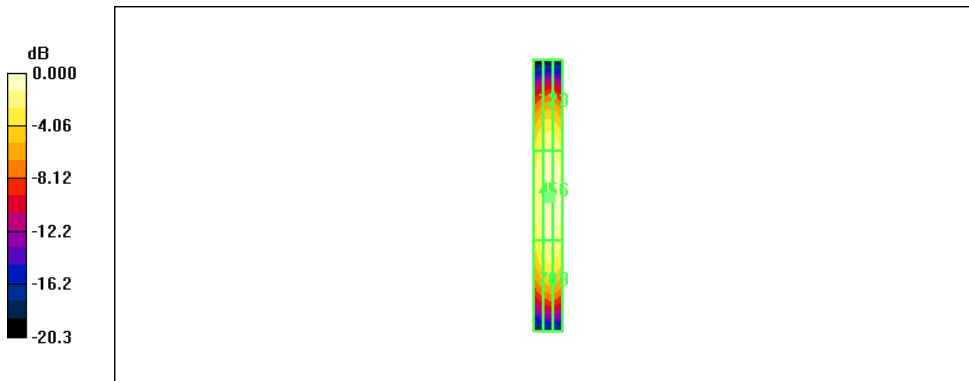

0 dB = 0.458A/m

Test Laboratory: HCT CO., LTD.  
 Ambient Temperature: 21.5 °C  
 Test Date: June 5, 2011

**DUT: HAC Dipole 1880 MHz; Type: CD1880V3; Serial:1019**

Communication System: CW; Frequency: 1880 MHz; Duty Cycle: 1:1  
 Medium parameters used:  $\sigma = 0$  mho/m,  $\epsilon_r = 1$ ;  $\rho = 1$  kg/m<sup>3</sup>  
 Phantom section: H Dipole Section ; Measurement SW: DASY4, V4.7 Build 71; Postprocessing SW: SEMCAD, V1.8 Build 184

- DASY4 Configuration:
- Probe: H3DV6 - SN6051; ; Calibrated: 2010-09-20
  - Sensor-Surface: (Fix Surface)
  - Electronics: DAE4 Sn869; Calibrated: 2010-09-21
  - Phantom: HAC Test Arch; Type: SD HAC P01 BA

**H Scan 10mm above CD 1880 MHz/Hearing Aid Compatibility Test (41x181x1):** Measurement grid: dx=5mm, dy=5mm

Maximum value of peak Total field = 0.459 A/m  
 Probe Modulation Factor = 1.00  
 Device Reference Point: 0.000, 0.000, 354.7 mm  
 Reference Value = 0.549 A/m; Power Drift = 0.003 dB  
**Hearing Aid Near-Field Category: M2 (AWF 0 dB)**

Peak H-field in A/m

Grid 1	Grid 2	Grid 3
0.377 M2	0.408 M2	0.402 M2
Grid 4	Grid 5	Grid 6
0.425 M2	0.459 M2	0.453 M2
Grid 7	Grid 8	Grid 9
0.393 M2	0.427 M2	0.422 M2

**Cursor:**

Total = 0.459 A/m  
 H Category: M2  
 Location: -1.5, 2, 366.6 mm

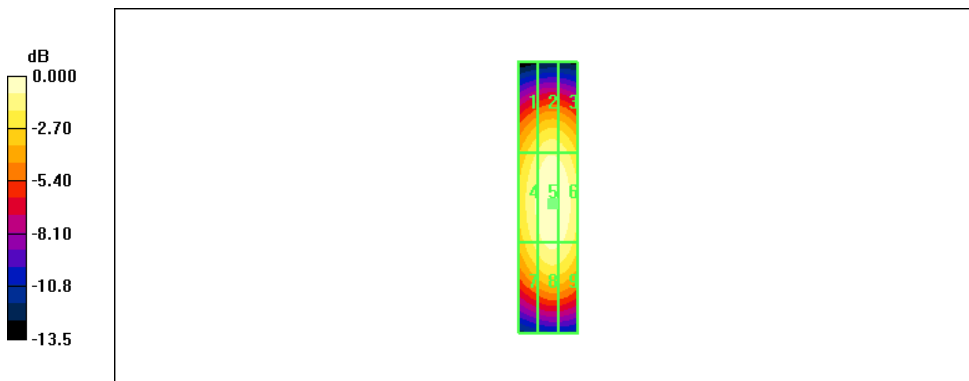

0 dB = 0.459A/m

Test Laboratory: HCT CO., LTD.  
 Ambient Temperature: 21.3 °C  
 Test Date: Aug. 22,2011

**DUT: HAC-Dipole 835 MHz; Type: D835V3; Serial: 1024**

Communication System: CW; Frequency: 835 MHz;Duty Cycle: 1:1  
 Medium parameters used:  $\sigma = 0$  mho/m,  $\epsilon_r = 1$ ;  $\rho = 1000$  kg/m<sup>3</sup>  
 Phantom section: E Dipole Section ; Measurement SW: DASY4, V4.7 Build 71; Postprocessing SW: SEMCAD, V1.8 Build 184

DASY4 Configuration:  
 - Probe: ER3DV6 - SN2343; ConvF(1, 1, 1); Calibrated: 2011-05-16  
 - Sensor-Surface: (Fix Surface)  
 - Electronics: DAE3 Sn466; Calibrated: 2011-03-01  
 - Phantom: HAC Test Arch; Type: SD HAC P01 BA

**E Scan 10mm above CD 835 MHz/Hearing Aid Compatibility Test (41x361x1):** Measurement grid: dx=5mm, dy=5mm  
 Maximum value of peak Total field = 167.7 V/m  
 Probe Modulation Factor = 1.00  
 Device Reference Point: 0.000, 0.000, 354.7 mm  
 Reference Value = 129.9 V/m; Power Drift = -0.013 dB  
**Hearing Aid Near-Field Category: M4 (AWF 0 dB)**

Peak E-field in V/m

Grid 1	Grid 2	Grid 3
157.3 M4	167.7 M4	165.4 M4
Grid 4	Grid 5	Grid 6
78.1 M4	85.2 M4	84.9 M4
Grid 7	Grid 8	Grid 9
148.8 M4	161.8 M4	160.7 M4

**Cursor:**  
 Total = 167.7 V/m  
 E Category: M4  
 Location: -1, -79, 365.8 mm

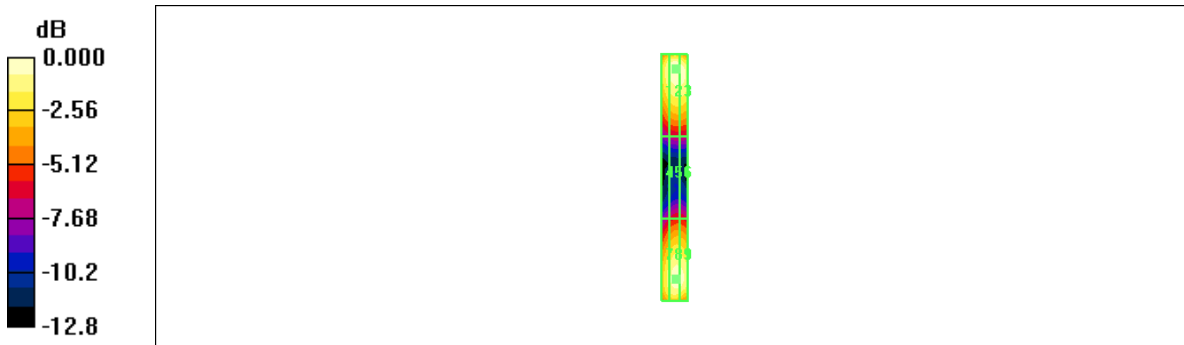

0 dB = 167.7V/m

Test Laboratory: HCT CO., LTD.  
 Ambient Temperature 21.3 °C  
 Test Date Aug. 22,2011

**DUT: HAC Dipole 1880 MHz; Type: CD1880V3; Serial: 1019**

Communication System: CW; Frequency: 1880 MHz; Duty Cycle: 1:1  
 Medium parameters used:  $\sigma = 0$  mho/m,  $\epsilon_r = 1$ ;  $\rho = 1000$  kg/m<sup>3</sup>  
 Phantom section: E Dipole Section ; Measurement SW: DASY4, V4.7 Build 71; Postprocessing SW: SEMCAD, V1.8 Build 184

**DASY4 Configuration:**

- Probe: ER3DV6 - SN2343; ConvF(1, 1, 1); Calibrated: 2011-05-16
- Sensor-Surface: (Fix Surface)
- Electronics: DAE3 Sn466; Calibrated: 2011-03-01
- Phantom: HAC Test Arch; Type: SD HAC P01 BA

**E Scan 10mm above CD 1880 MHz/Hearing Aid Compatibility Test (41x181x1):** Measurement grid: dx=5mm, dy=5mm

Maximum value of peak Total field = 141.8 V/m

Probe Modulation Factor = 1.00

Device Reference Point: 0.000, 0.000, 354.7 mm

Reference Value = 167.2 V/m; Power Drift = 0.005 dB

**Hearing Aid Near-Field Category: M2 (AWF 0 dB)**

Peak E-field in V/m

Grid 1 130.7 M2	Grid 2 138.8 M2	Grid 3 136.9 M2
Grid 4 87.7 M3	Grid 5 95.6 M3	Grid 6 95.5 M3
Grid 7 129.7 M2	Grid 8 141.8 M2	Grid 9 140.8 M2

**Cursor:**

Total = 141.8 V/m

E Category: M2

Location: -1.5, 33.5, 365.8 mm

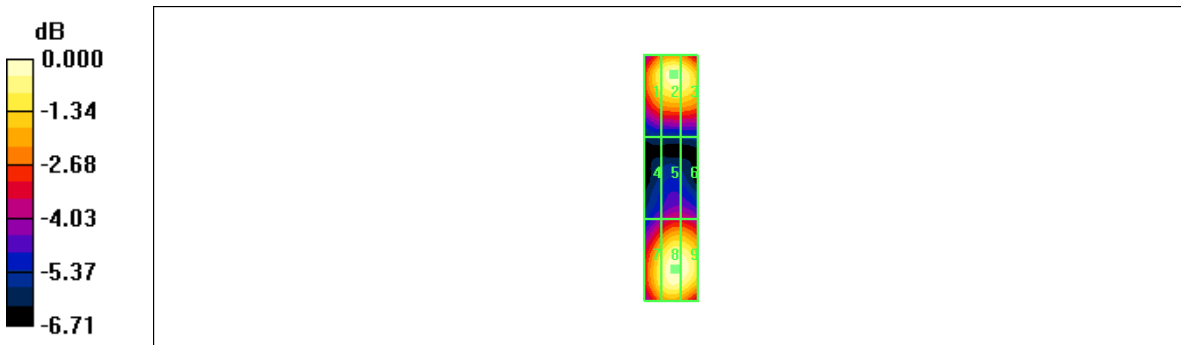

0 dB = 141.8V/m

Test Laboratory: HCT CO., LTD.

Ambient Temperature 21.3 °C

Test Date Aug. 22,2011

**DUT: HAC-Dipole 835 MHz; Type: D835V3; Serial: 1024**

Communication System: CW; Frequency: 835 MHz; Duty Cycle: 1:1

Medium parameters used:  $\sigma = 0$  mho/m,  $\epsilon_r = 1$ ;  $\rho = 1$  kg/m<sup>3</sup>

Phantom section: H Dipole Section ; Measurement SW: DASY4, V4.7 Build 71; Postprocessing SW: SEMCAD, V1.8 Build 184

DASY4 Configuration:

- Probe: H3DV6 - SN6101; ; Calibrated: 2011-05-18
- Sensor-Surface: (Fix Surface)
- Electronics: DAE3 Sn466; Calibrated: 2011-03-01
- Phantom: HAC Test Arch; Type: SD HAC P01 BA

**H Scan 10mm above CD 835 MHz/Hearing Aid Compatibility Test (41x361x1):** Measurement grid: dx=5mm, dy=5mm

Maximum value of peak Total field = 0.486 A/m

Probe Modulation Factor = 1.00

Device Reference Point: 0.000, 0.000, 354.7 mm

Reference Value = 0.589 A/m; Power Drift = -0.016 dB

**Hearing Aid Near-Field Category: M4 (AWF 0 dB)**

Peak H-field in A/m

Grid 1	Grid 2	Grid 3
0.388 M4	0.421 M4	0.415 M4
Grid 4	Grid 5	Grid 6
0.447 M4	0.486 M4	0.479 M4
Grid 7	Grid 8	Grid 9
0.393 M4	0.428 M4	0.422 M4

**Cursor:**

Total = 0.486 A/m

H Category: M4

Location: -1.5, 0, 366.6 mm

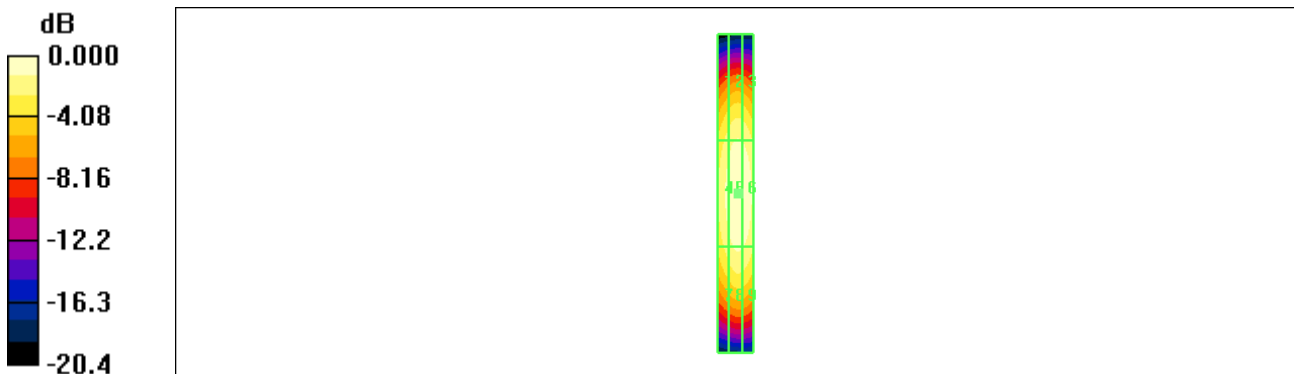

0 dB = 0.486A/m



Test Laboratory: HCT CO., LTD.  
 Ambient Temperature: 21.3 °C  
 Test Date: Aug. 22,2011

**DUT: HAC Dipole 1880 MHz; Type: CD1880V3; Serial: 1019**

Communication System: CW; Frequency: 1880 MHz; Duty Cycle: 1:1  
 Medium parameters used:  $\sigma = 0$  mho/m,  $\epsilon_r = 1$ ;  $\rho = 1$  kg/m<sup>3</sup>  
 Phantom section: H Dipole Section ; Measurement SW: DASY4, V4.7 Build 71; Postprocessing SW: SEMCAD, V1.8 Build 184

DASY4 Configuration:  
 - Probe: H3DV6 - SN6101; ; Calibrated: 2011-05-18  
 - Sensor-Surface: (Fix Surface)  
 - Electronics: DAE3 Sn466; Calibrated: 2011-03-01  
 - Phantom: HAC Test Arch; Type: SD HAC P01 BA

**H Scan 10mm above CD 1880 MHz/Hearing Aid Compatibility Test (41x181x1):** Measurement grid: dx=5mm, dy=5mm  
 Maximum value of peak Total field = 0.475 A/m  
 Probe Modulation Factor = 1.00  
 Device Reference Point: 0.000, 0.000, 354.7 mm  
 Reference Value = 0.565 A/m; Power Drift = 0.040 dB  
**Hearing Aid Near-Field Category: M2 (AWF 0 dB)**

Peak H-field in A/m

Grid 1	Grid 2	Grid 3
0.392 M2	0.423 M2	0.417 M2
Grid 4	Grid 5	Grid 6
0.441 M2	0.475 M2	0.469 M2
Grid 7	Grid 8	Grid 9
0.408 M2	0.442 M2	0.437 M2

Cursor:  
 Total = 0.475 A/m  
 H Category: M2  
 Location: -1.5, 1.5, 366.6 mm

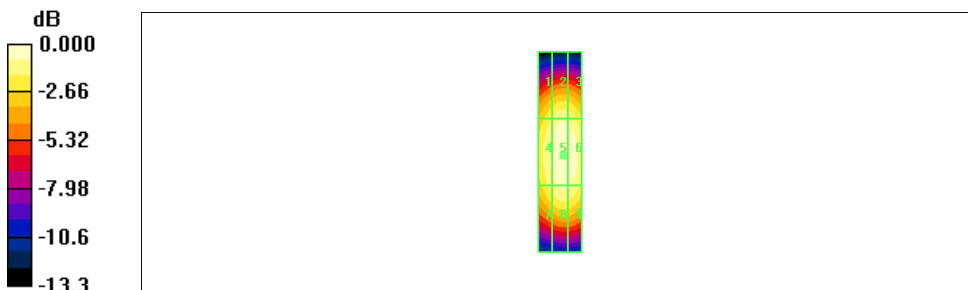

0 dB = 0.475A/m