



HCT CO., LTD.

CERTIFICATE OF COMPLIANCE FCC Certification

Applicant Name:

Pantech Co.,Ltd.

Date of Issue:

June 16, 2011

Location:HCT CO., LTD., 105-1, Jangam-ri, Majang-Myeon,
Icheon-si, Kyunggi-Do, Korea**Address:**DMC I-2, PANTECH R&D Center Sang Am dong, Mapogu,
121-792, Korea**Test Report No.:** HCTR1106FR25**HCT FRN:** 0005866421**FCC ID:** JYCAPACHE**APPLICANT:** PANTECH CO., LTD.**FCC Model(s):** ADR8995**EUT Type:** CDMA/LTE Phone with Bluetooth & WLAN**FCC Classification:** PCS Licensed Transmitter (PCB)**FCC Rule Part(s):** §2 , §27**Tx Frequency:** 782 MHz (LTE – Band 13)**Max. RF Output Power:** 0.109W (20.36 dBm) ERP (QPSK)
0.102W (20.09 dBm) ERP (16-QAM)**Emission Designator(s):** 8M90G7D (QPSK) / 8M92W7D (16-QAM)

The measurements shown in this report were made in accordance with the procedures specified in §2.947. I assume full responsibility for the accuracy and completeness of these measurements, and for the qualifications of all persons taking them.

HCT CO., LTD. Certifies that no party to this application has subject to a denial of Federal benefits that includes FCC benefits pursuant to section 5301 of the Anti-Drug Abuse Act of 1998, 21 U.S. C. 853(a)

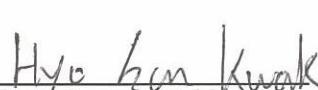
Report prepared by
: Hyo Sun Kwak

Test engineer of RF Team

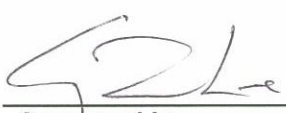
Approved by
: Sang Jun Lee

Manager of RF Team

This report only responds to the tested sample and may not be reproduced, except in full, without written approval of the HCT Co., Ltd.

FCC CERTIFICATION REPORT				www.hct.co.kr
Test Report No. HCTR1106FR25	Date of Issue: June 16, 2011	EUT Type: CDMA/LTE Phone with Bluetooth & WLAN	FCC ID: JYCAPACHE	Page 1 of 42

Version

TEST REPORT NO.	DATE	DESCRIPTION
HCTR1106FR25	June 16, 2011	First Approval Report

Table of Contents

1. GENERAL INFORMATION		4
2. INTRODUCTION		5
2.1. EUT DESCRIPTION.....		5
2.2. MEASURING INSTRUMENT CALIBRATION.....		5
2.3. TEST FACILITY		5
3. DESCRIPTION OF TESTS		6
3.1 EFFECTIVE RADIATED POWER/EQUIVALENT ISOTROPIC RADIATED POWER.....		6
3.2 OCCUPIED BANDWIDTH.		7
3.3 BLOCK FREQUENCY RANGE		8
3.4 SPURIOUS AND HARMONIC EMISSIONS AT ANTENNA TERMINAL.....		9
3.5 RADIATED SPURIOUS AND HARMONIC EMISSIONS		10
3.6 FREQUENCY STABILITY / VARIATION OF AMBIENT TEMPERATURE		11
4. LIST OF TEST EQUIPMENT		12
5. SUMMARY OF TEST RESULTS		13
6. SAMPLE CALCULATION		14
7. TEST DATA		15
7.1 CONDUCTED OUTPUT POWER		15
7.2 OCCUPIED BANDWIDTH		16
7.3 CONDUCTED SPURIOUS EMISSIONS		17
7.3.1 BAND EDGE.....		17
7.4 EFFECTIVE RADIATED POWER OUTPUT		18
7.5 RADIATED SPURIOUS EMISSIONS.....		19
7.5.1 RADIATED SPURIOUS EMISSIONS.....		19
7.5.2 RADIATED SPURIOUS EMISSIONS (1559 ~ 1610 MHz Band)		20
7.6 FREQUENCY STABILITY / VARIATION OF AMBIENT TEMPERATURE		21
7.6.1 FREQUENCY STABILITY (LTE).....		21
8. TEST PLOTS.....		22



MEASUREMENT REPORT

1. GENERAL INFORMATION

Applicant Name: Pantech Co., Ltd.

Address: DMC I-2, PANTECH R&D Center Sang Am dong, Mapogu,
121-792, Korea

FCC ID: JYCAPACHE

Application Type: Certification

FCC Classification: PCS Licensed Transmitter (PCB)

FCC Rule Part(s): §2 , §27

EUT Type: CDMA/LTE Phone with Bluetooth & WLAN

FCC Model(s): ADR8995

Tx Frequency: 782 MHz (LTE – Band 13)

Max. RF Output Power: 0.109W (20.36 dBm) ERP (QPSK)
0.102W (20.09 dBm) ERP (16-QAM)

Emission Designator(s): 8M90G7D (QPSK) / 8M92W7D (16-QAM)

Antenna Specification Manufacturer: KARAM Solution
Antenna type: PIFA Antenna
Peak Gain: -2.70 dBi

Date(s) of Tests: May 09, 2011 ~ May 13, 2011

FCC CERTIFICATION REPORT				www.hct.co.kr
Test Report No. HCTR1106FR25	Date of Issue: June 16, 2011	EUT Type: CDMA/LTE Phone with Bluetooth & WLAN	FCC ID: JYCAPACHE	Page 4 of 42



2. INTRODUCTION

2.1. EUT DESCRIPTION

The PANTECH CO., LTD. ADR8995 CDMA/LTE Phone with Bluetooth & WLAN consists of Cellular CDMA, PCS CDMA and 1xEVDO Rev.A, LTE Band 13.

2.2. MEASURING INSTRUMENT CALIBRATION

The measuring equipment, which was utilized in performing the tests documented herein, has been calibrated in accordance with the manufacturer's recommendations for utilizing calibration equipment, which is traceable to recognized national standards.

2.3. TEST FACILITY

The SAC(Semi-Anechoic Chamber) and conducted measurement facility used to collect the radiated data are located at the 105-1, Jangam-ri, Majang-Myeon, Icheon-si, Kyunggi-Do, 467-811, Korea. The site is constructed in conformance with the requirements of ANSI C63.4 and CISPR Publication 22. Detailed description of test facility was submitted to the Commission and accepted dated March 02, 2011 (Registration Number: 90661)

FCC CERTIFICATION REPORT				www.hct.co.kr
Test Report No. HCTR1106FR25	Date of Issue: June 16, 2011	EUT Type: CDMA/LTE Phone with Bluetooth & WLAN	FCC ID: JYCAPACHE	Page 5 of 42

3. DESCRIPTION OF TESTS

3.1 EFFECTIVE RADIATED POWER/EQUIVALENT ISOTROPIC RADIATED POWER

Test Set-up

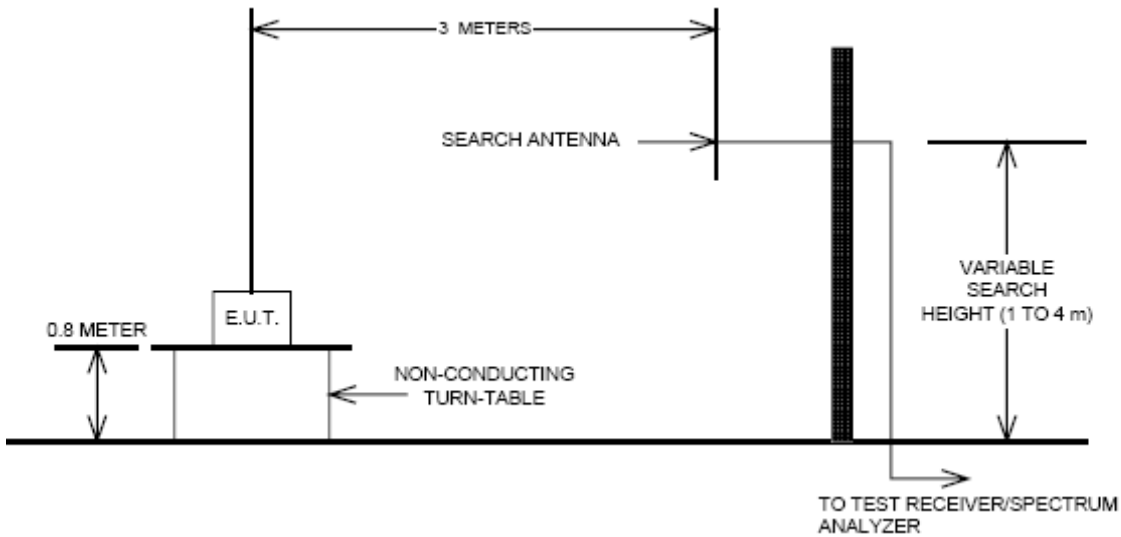

Test Procedure

Radiated emission measurements were performed at an SAC(Semi-Anechoic Chamber)

The equipment under test is placed on a non-conductive styrofoam resin table 3-meters from the receive antenna. A styrofoam turntable was rotated 360° and the receiving antenna scanned from 1-4m in order to capture the maximum emission. A half wave dipole was substituted in place of the EUT. This dipole antenna was driven by a signal generator and the previously recorded signal was duplicated.

The maximum EIRP was calculated by adding the forward power to the calibrated source plus its appropriate gain value. These steps were carried out with the receiving antenna in both vertical and horizontal polarization. For readings above 1GHz, the above procedure is repeated using horn antennas and the difference between the gain of the horn and an isotropic antenna are taken into consideration.

3.2 OCCUPIED BANDWIDTH.

Test set-up

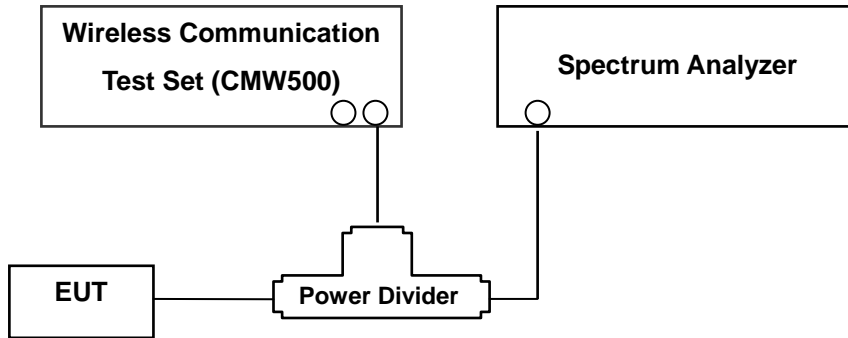

(Configuration of conducted Emission measurement)
 Test Procedure

The EUT was setup to maximum output power at its lowest channel. The occupied bandwidth was measured using a spectrum analyzer. The measurements are repeated for the highest and a middle channel. The EUT's occupied bandwidth is measured as the width of the signal between two points, one below the carrier center frequency and one above the carrier frequency, outside of which all emissions are attenuated at least 26 dB below the transmitter power. Plots of the EUT's occupied bandwidth are shown herein.



3.3 BLOCK FREQUENCY RANGE

Two paired channels of 11 megahertz each are available for assignment in Block C in the 746–757 MHz and 776 – 787 MHz bands. In the event that no licenses for two channels in this Block C are assigned based on the results of the first auction in which such licenses were offered because the auction results do not satisfy the applicable reserve price, the spectrum in the 746 – 757 MHz and 776 – 787 MHz bands will instead be made available for assignment at a subsequent auction as follows:

- (i) Two paired channels of 6 megahertz each available for assignment in Block C1 in the 746–752 MHz and 776–782 MHz bands.
- (ii) Two paired channels of 5 megahertz each available for assignment in Block C2 in the 752–757 MHz and 782–787 MHz bands

FCC CERTIFICATION REPORT				www.hct.co.kr
Test Report No. HCTR1106FR25	Date of Issue: June 16, 2011	EUT Type: CDMA/LTE Phone with Bluetooth & WLAN	FCC ID: JYCAPACHE	Page 8 of 42



3.4 SPURIOUS AND HARMONIC EMISSIONS AT ANTENNA TERMINAL.

Test Procedure

The level of the carrier and the various conducted spurious and harmonic frequencies is measured by means of a calibrated spectrum analyzer.

The EUT was setup to maximum output power at its lowest channel. The Resolution BW of the analyzer is set to 1 % of the emission bandwidth to show compliance with the – 13 dBm limit, in the 1 MHz bands immediately outside and adjacent to the edge of the frequency block. The 1 MHz RBW was used to scan from 30 MHz to 26.5 GHz. A display line was placed at – 13 dBm to show compliance. The high, lowest and a middle channel were tested for out of band measurements.

- Band Edge Requirement : In the 1MHz bands immediately outside and adjacent to the frequency block, a resolution bandwidth of at least 1 percent of the emission bandwidth of the fundamental emission of the transmitter may be employed to measure the out of band Emissions. Limit, -13dBm.

FCC CERTIFICATION REPORT				www.hct.co.kr
Test Report No. HCTR1106FR25	Date of Issue: June 16, 2011	EUT Type: CDMA/LTE Phone with Bluetooth & WLAN	FCC ID: JYCAPACHE	Page 9 of 42

3.5 RADIATED SPURIOUS AND HARMONIC EMISSIONS

Test Set-up

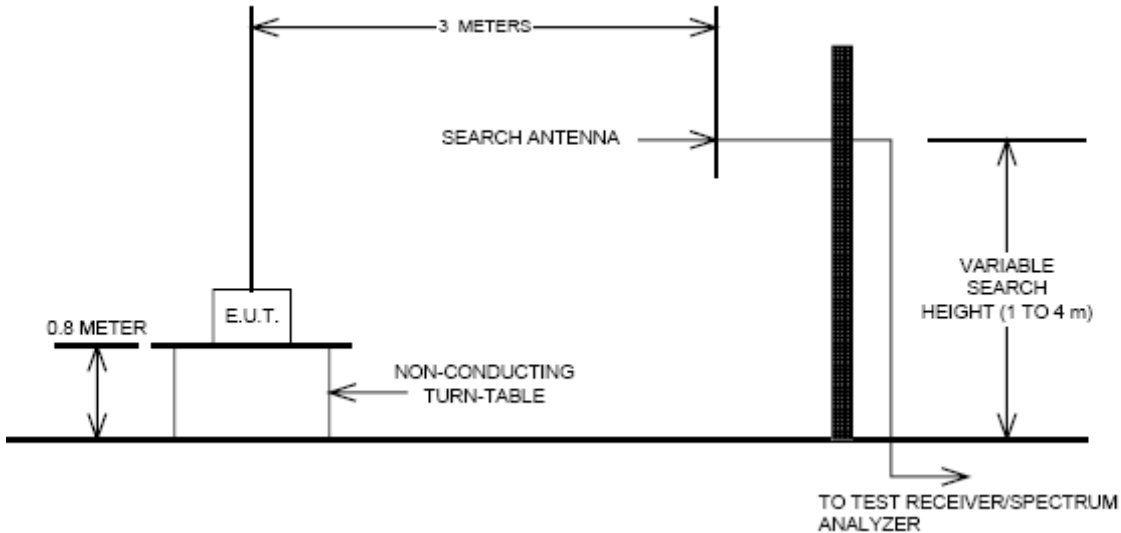

The measurement facilities used for this test have been documented in previous filings with the commission pursuant to section § 2.948. The SAC(Semi-Anechoic Chamber) meets requirements in ANSI C63.4 –2003. A mast capable of lifting the receiving antenna from a height of one to four meters is used together with a rotatable styrofoam platform mounted at three from the antenna mast.

- 1) The unit mounted on a styrofoam turntable 1.5 m × 1.0 m × 0.80 m is 0.8 meter above test site ground level.
- 2) During the emission test, the turntable is rotated and the EUT is manipulated to find the configuration resulting in maximum emission under normal condition of installation and operation.
- 3) The antenna height and polarization are also varied from 1 to 4 meters until the maximum signal is found.
- 4) The spectrum shall be scanned up to the 10th harmonic of the fundamental frequency.

Test Procedure

The equipment under test is placed on a non-conductive styrofoam resin table 3-meters from the receive antenna. A styrofoam turntable was rotated 360° and the receiving antenna scanned from 1-4m in order to capture the maximum emission. A half wave dipole was substituted in place of the EUT. This dipole antenna was driven by a signal generator and the previously recorded signal was duplicated.

The maximum EIRP was calculated by adding the forward power to the calibrated source plus its appropriate gain value. These steps were carried out with the receiving antenna in both vertical and horizontal polarization. For readings above 1GHz, the above procedure is repeated using horn antennas and the difference between the gain of the horn and an isotropic antenna are taken into consideration.

3.6 FREQUENCY STABILITY / VARIATION OF AMBIENT TEMPERATURE

Test Set-up

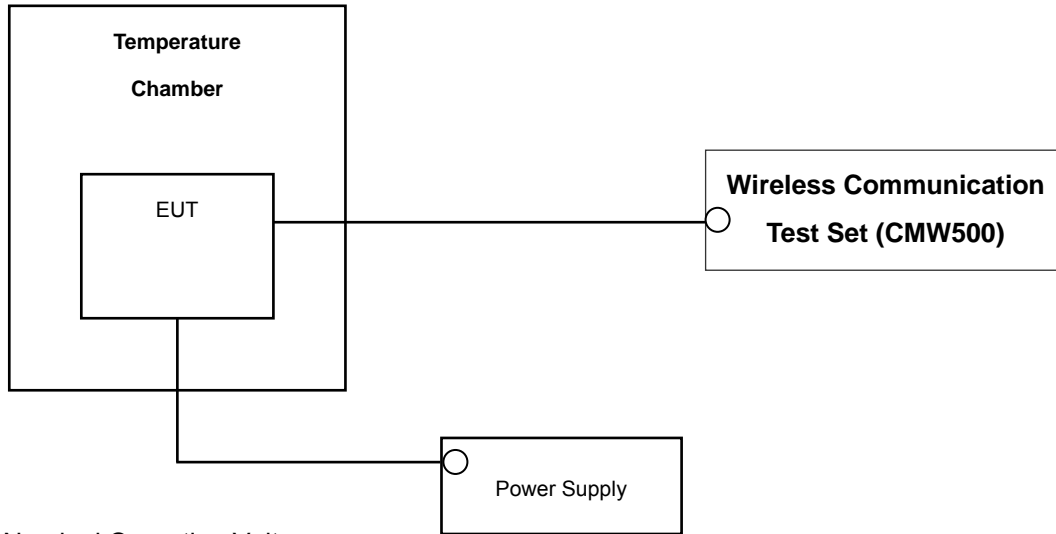

* Nominal Operating Voltage

Test Procedure

The frequency stability of the transmitter is measured by:

a.) **Temperature:** The temperature is varied from - 30 °C to + 50 °C using an environmental chamber.

b.) **Primary Supply Voltage:** The primary supply voltage is varied from battery end point to 115 % of the voltage normally at the input to the device or at the power supply terminals if cables are not normally supplied.

Specification — the frequency stability shall be sufficient to ensure that the fundamental emission stays within the authorized frequency block. The frequency stability of the transmitter shall be maintained within $\pm 0.00025\%$ (± 2.5 ppm) of the center frequency.

Time Period and Procedure:

The carrier frequency of the transmitter is measured at room temperature (20°C to provide a reference).

1. The equipment is turned on in a “standby” condition for one minute before applying power to the transmitter. Measurement of the carrier frequency of the transmitter is made within one minute after applying power to the transmitter.

2. Frequency measurements are made at 10°C intervals ranging from -30°C to +50°C. A period of at least one half-hour is provided to allow stabilization of the equipment at each temperature level.

NOTE: The EUT is tested down to the battery endpoint.

4. LIST OF TEST EQUIPMENT

Manufacture	Model/ Equipment	Serial Number	Calibration Interval	Calibration Due
R&S	N9020A	MY51110020	Annual	04/16/2012
Agilent	E4416A/ Power Meter	GB41291412	Annual	01/04/2012
Agilent	E9327A/ Power Sensor	MY4442009	Annual	07/23/2011
R&S	CMW500/ Base Station	101901	Annual	08/05/2011
MITEQ	AMF-6D-001180-35-20P/AMP	990893	Annual	05/02/2012
Wainwright	WHK1.2/15G-10EF/H.P.F	2	Annual	05/02/2012
Wainwright	WHK3.3/18G-10EF/H.P.F	1	Annual	05/02/2012
Agilent	775D/ Dual Directional Coupler	12922	Annual	12/29/2011
Agilent	11636B/ Power Divider	11377	Annual	12/29/2011
Digital	EP-3010/ Power Supply	3110117	Annual	01/04/2012
Schwarzbeck	UHAP/ Dipole Antenna	949	Biennial	03/18/2012
Schwarzbeck	UHAP/ Dipole Antenna	950	Biennial	03/18/2012
Korea Engineering	KR-1005L / Chamber	KRAB07063-2CH	Annual	12/28/2011
Schwarzbeck	BBHA 9120D/ Horn Antenna	296	Biennial	09/23/2011
Schwarzbeck	BBHA 9120D/ Horn Antenna	147	Biennial	04/13/2012
Agilent	E4440A/Spectrum Analyzer	US45303008	Annual	06/09/2011

5. SUMMARY OF TEST RESULTS

FCC Part Section(s)	Test Description	Test Limit	Test Condition	Test Result
2.1049	Occupied Bandwidth	N/A	CONDUCTED	PASS
2.1051, 27.53(c)(2)	Band Edge / Spurious and Harmonic Emissions at Antenna Terminal.	< 43 + 10 log ₁₀ (P[Watts]) < 65 + 10 log ₁₀ (P[Watts]) in a 6.25 KHz bandwidth for emissions in the 763 – 775 MHz and 793 – 805 MHz bands		PASS
2.1046	Conducted Output Power	N/A		PASS
2.1055, 27.54	Frequency stability / variation of ambient temperature	< 2.5 ppm		PASS
27.50(b)(10)	Effective Radiated Power	< 3 Watts max. ERP	RADIATED	PASS
2.1053, 27.53(c)(2) 27.53©(4)	Undesirable Out-of-Band Emissions	< 43 + 10 log ₁₀ (P[Watts]) for all out-of-band emissions		PASS
2.1053,27.53(f)	Undesirable Emissions in the 1559 – 1610 MHz band	< -40dBm/MHz EIRP (wideband) < -50dBm EIRP (narrowband)		PASS

6. SAMPLE CALCULATION

A. ERP Sample Calculation

Mode	Ch./ Freq.		Measured Level(dBm)	Substitute LEVEL(dBm)	Ant. Gain	C.L	Pol.	ERP	
	channel	Freq.(MHz)						W	dBm
LTE	23230	782	-11.56	34.28	-8.32	1.17	H	0.30	24.79

ERP = SubstituteLEVEL(dBm) + Ant. Gain – CL(Cable Loss)

- 1) The EUT mounted on a wooden tripod is 0.8 meter above test site ground level.
- 2) During the test , the turn table is rotated and the antenna height is also varied from 1 to 4 meters until the maximum signal is found.
- 3) Record the field strength meter's level.
- 4) Replace the EUT with dipole/Horn antenna that is connected to a calibrated signal generator.
- 5) Increase the signal generator output till the field strength meter's level is equal to the item (3).
- 6) The signal generator output level with Ant. Gain and cable loss are the rating of effective radiated power (ERP).

B. Emission Designator

QPSK Modulation

Emission Designator = 8M95G7D

LTE BW = 8.95 MHz

G = Phase Modulation

7 = Quantized/Digital Info

D = Amplitude/Angle Modulated

16QAM Modulation

Emission Designator = 8M94W7D

LTE BW = 8.94 MHz

D = Amplitude/Angle Modulated

7 = Quantized/Digital Info

W = Combination (Audio/Data)

7. TEST DATA

7.1 CONDUCTED OUTPUT POWER

A base station simulator was used to establish communication with the EUT. The base station simulator parameters were set to produce the maximum power from the EUT. This device was tested under all configurations and the highest power is reported. Conducted Output Powers of EUT are reported below.

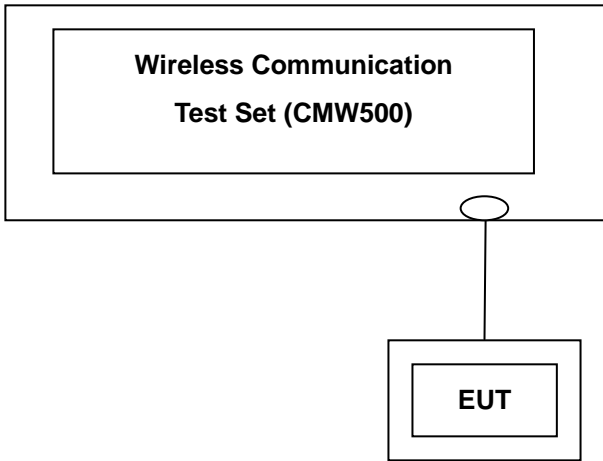

Test Result

Band	Frequency(Mhz)	Channel	Resource Block Size	Resource Block Offset	Average Power [dBm]	
					QPSK	16-QAM
LTE	782	23230	1	0	23.32	22.38
			1	49	23.23	22.25
			25	12	22.31	21.18
			50	0	22.23	21.14

(LTE Conducted Average Output Powers)

Note : Detecting mode is average.

7.2 OCCUPIED BANDWIDTH

Band	Frequency(Mhz)	Modulation	Resource Block Size	Resource Block Offset	Data (RB 1 : KHz / RB 25,50 : MHz)
LTE	782	QPSK	1	0	509.57
	782		1	49	506.25
	782		25	12	4.5466
	782		50	-	8.9033
	782	16-QAM	1	0	508.38
	782		1	49	533.76
	782		25	12	4.5390
	782		50	-	8.9221

- Plots of the EUT's Occupied Bandwidth are shown Page 27 ~ 30.

7.3 CONDUCTED SPURIOUS EMISSIONS

Band	Frequency (Mhz)	Modulation	Resource Block Size	Resource Block Offset	Frequency of Maximum Harmonic (GHz)	Maximum Data [dBm]
LTE	782	QPSK	1	0	5.1125	-36.362
	782		1	49	2.2654	-34.402
	782		25	12	2.4407	-35.662
	782		50	-	2.4037	-35.020
	782	16-QAM	1	0	5.3105	-36.100
	782		1	49	2.4358	-35.288
	782		25	12	5.5965	-35.957
	782		50	-	2.2234	-34.896

- Plots of the EUT's Conducted Spurious Emissions are shown Page 31 ~ 38.

7.3.1 BAND EDGE

Note : In the 763 – 775 MHz and 793 – 805 MHz band, the FCC limit is $65 + 10\log_{10}(P_{\text{Watts}}) = -35$ dBm in a 6.25 KHz bandwidth.

By using a 10KHz bandwidth, the limit was adjusted by $10\log_{10}(10\text{KHz}/6.25\text{KHz}) = 2.04$ dB.

LIMIT : - 35 dBm + 2.04 dB = - 32.96 dBm.

- Plots of the EUT's Band Edge are shown Page 23 ~ 26, 39 ~ 42.

7.4 EFFECTIVE RADIATED POWER OUTPUT

(10 MHz)

Ch / Freq		Modulation	Measured Level (dBm)	Substitute Level (dBm)	Ant. Gain(dBd)	C.L	Pol	ERP	
channel	Freq (MHz)							W	dBm
23230	782.00	QPSK	-15.77	32.25	-10.36	1.53	V	0.11	20.36
		16-QAM	-16.04	31.75	-10.36	1.30	V	0.10	20.09

Note: Worst case is 1 resource block. This unit was tested with a notebook computer.

NOTES:

Effective Radiated Power Output Measurements by Substitution Method
according to ANSI/TIA/EIA-603-C-2004, Aug. 17, 2004:

The EUT was placed on a non-conductive styrofoam resin table 3-meters from the receive antenna. The receive antenna height and turntable rotation was adjusted for the highest reading on the receive spectrum analyzer. For 1 MHz BW signals, a peak detector is used, with RBW = VBW = 1 MHz. For 10 MHz BW signals, a peak detector is used, with RBW = VBW = 10 MHz. A half-wave dipole was substituted in place of the EUT. This dipole antenna was driven by a signal generator and the level of the signal generator was adjusted to obtain the same receive spectrum analyzer reading. The conducted power at the terminals of the dipole is measured. The ERP is recorded.

Also, we have done x, y, z planes in EUT and horizontal and vertical polarization in detecting antenna. The worst case of the EUT is Y plane in LTE mode. Also worst case of detecting Antenna is vertical polarization in LTE mode.

7.5 RADIATED SPURIOUS EMISSIONS

7.5.1 RADIATED SPURIOUS EMISSIONS

- ▣ OPERATING FREQUENCY : 782.00 MHz
- ▣ MEASURED OUTPUT POWER: 20.36 dBm = 0.109W
- ▣ MODULATION SIGNAL: QPSK
- ▣ DISTANCE: 3 meters
- ▣ LIMIT: - (43 + 10 log₁₀ (W)) = - 33.36 dBc

Ch	Freq (MHz)	Measured Level (dBm)	Ant. Gain (dBd)	Substitute Level (dBm)	C.L	Pol	ERP (dBm)	dBc
23230 (782.00)	2346.00	-51.74	10.72	-56.25	3.32	V	-48.85	-69.21
	3128.00	-	-	-	-	-	-	-
	3910.00	-	-	-	-	-	-	-

- NOTES:**
1. Radiated Spurious Emission Measurements at 3 meters by Substitution Method according to ANSI/TIA/EIA-603-C-2004, Aug. 17, 2004:
 2. The magnitude of spurious emissions attenuated more than 20dB below the limit above 5th Harmonic for all channel.
 3. we have done x, y, z planes in EUT and horizontal and vertical polarization in detecting antenna.
 4. Worst case is 1 resource block.

7.5.2 RADIATED SPURIOUS EMISSIONS (1559 ~ 1610 MHz Band)

- ▣ OPERATING FREQUENCY : 782.00 MHz
- ▣ MODULATION SIGNAL: QPSK
- ▣ DISTANCE: 3 meters
- ▣ NARROWBAND EMISSION LIMIT: - 50 dBm
- ▣ WIDEBAND EMISSION LIMIT: - 40 dBm/MHz

FREQUENCY (MHz)	EMISSION TYPE	Measured Level (dBm)	Ant. Gain (dBd)	Substitute Level (dBm)	C.L	Pol	ERP (dBm)	MARGIN (dB)
1598.06	WIDEBAND	-52.79	8.95	-61.12	2.57	H	-54.74	-14.74

- NOTES:**
1. Radiated Spurious Emission Measurements at 3 meters by Substitution Method according to ANSI/TIA/EIA-603-C-2004, Aug. 17, 2004:
 2. The magnitude of spurious emissions attenuated more than 20dB below the limit above 5th Harmonic for all channel.
 3. we have done x, y, z planes in EUT and horizontal and vertical polarization in detecting antenna.
 4. Worst case is 1 resource block.

7.6 FREQUENCY STABILITY / VARIATION OF AMBIENT TEMPERATURE

7.6.1 FREQUENCY STABILITY (LTE)

OPERATING FREQUENCY: 782,000,000 Hz
 CHANNEL: 23230
 REFERENCE VOLTAGE: 5 VDC
 DEVIATION LIMIT: ± 0.000 25 % or 2.5 ppm

Voltage (%)	Power (VDC)	Temp. (°C)	Frequency (Hz)	Frequency Error (Hz)	Deviation (%)	ppm
100%	3.700	+20(Ref)	782 000 001	0	0.000 000	0.000
100%		-30	781 999 998	-2.45	0.000 000	-0.003
100%		-20	781 999 999	-0.66	0.000 000	-0.001
100%		-10	781 999 999	-1.10	0.000 000	-0.001
100%		0	781 999 999	-0.64	0.000 000	-0.001
100%		+10	782 000 002	1.57	0.000 000	0.002
100%		+30	781 999 998	-1.90	0.000 000	-0.002
100%		+40	781 999 999	-0.64	0.000 000	-0.001
100%		+50	782 000 001	0.62	0.000 000	0.001
115%		4.255	+20	781 999 999	-0.87	0.000 000
Batt. Endpoint	3.400	+20	782 000 001	0.54	0.000 000	0.001

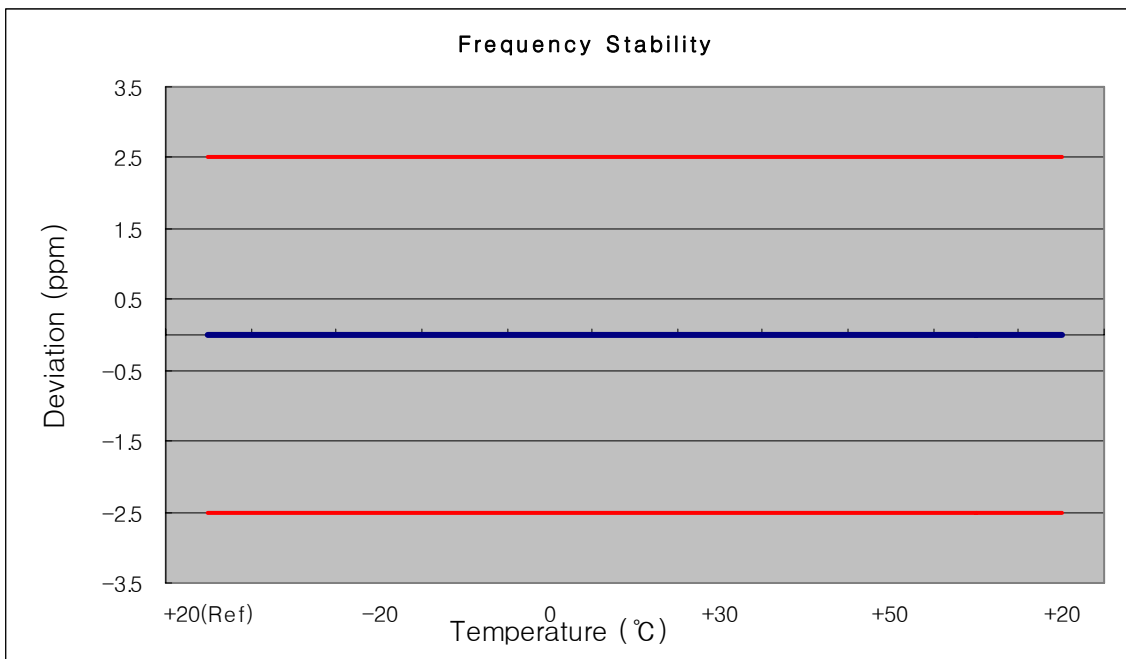



8. TEST PLOTS

FCC CERTIFICATION REPORT				www.hct.co.kr
Test Report No. HCTR1106FR25	Date of Issue: June 16, 2011	EUT Type: CDMA/LTE Phone with Bluetooth & WLAN	FCC ID: JYCAPACHE	Page 22 of 42

■ Occupied Bandwidth (QPSK – RB Size 1, RB Offset 0)

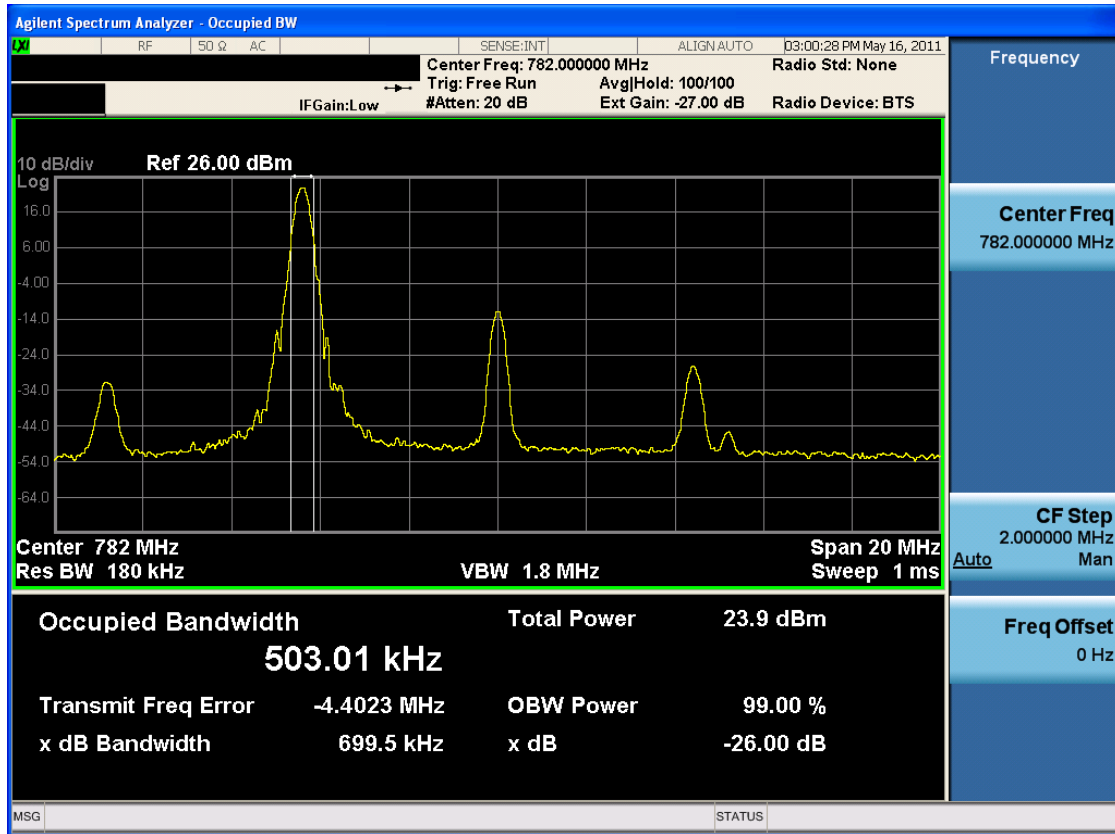

■ Occupied Bandwidth (QPSK – RB Size 1, RB Offset 49)

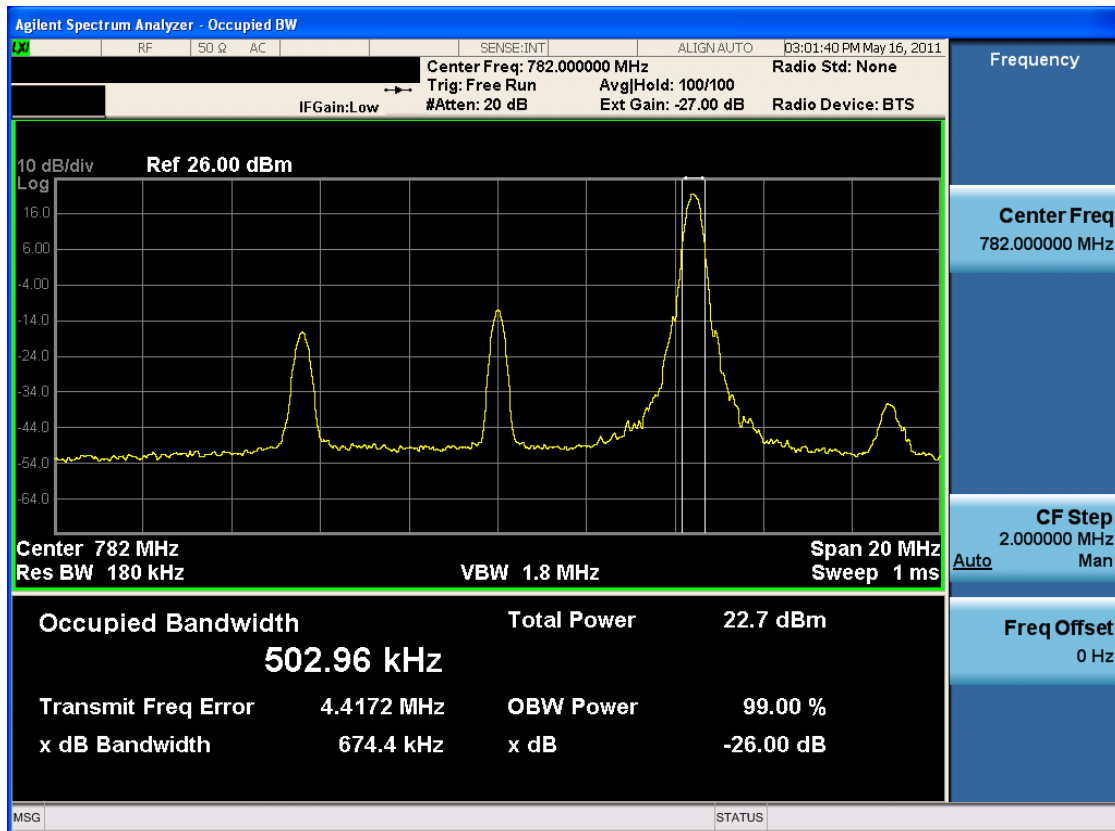

■ Occupied Bandwidth (QPSK – RB Size 25, RB Offset 12)

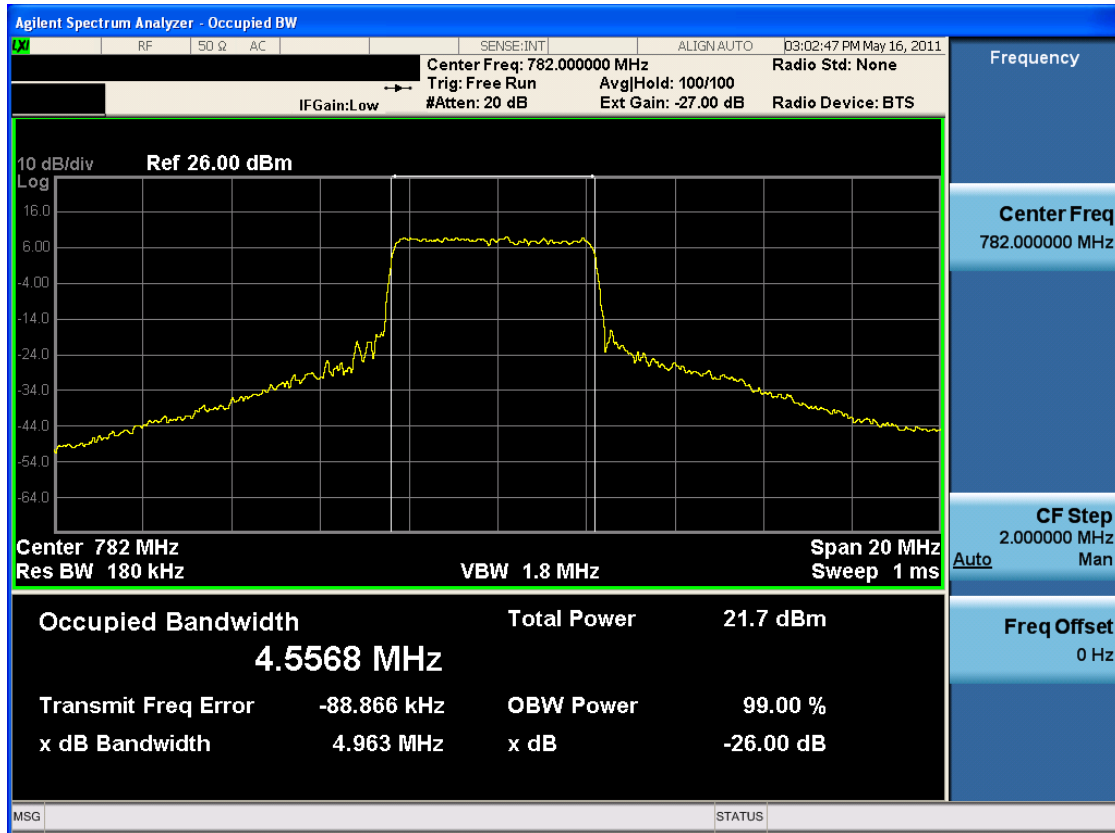

■ Occupied Bandwidth (QPSK – RB Size 50)

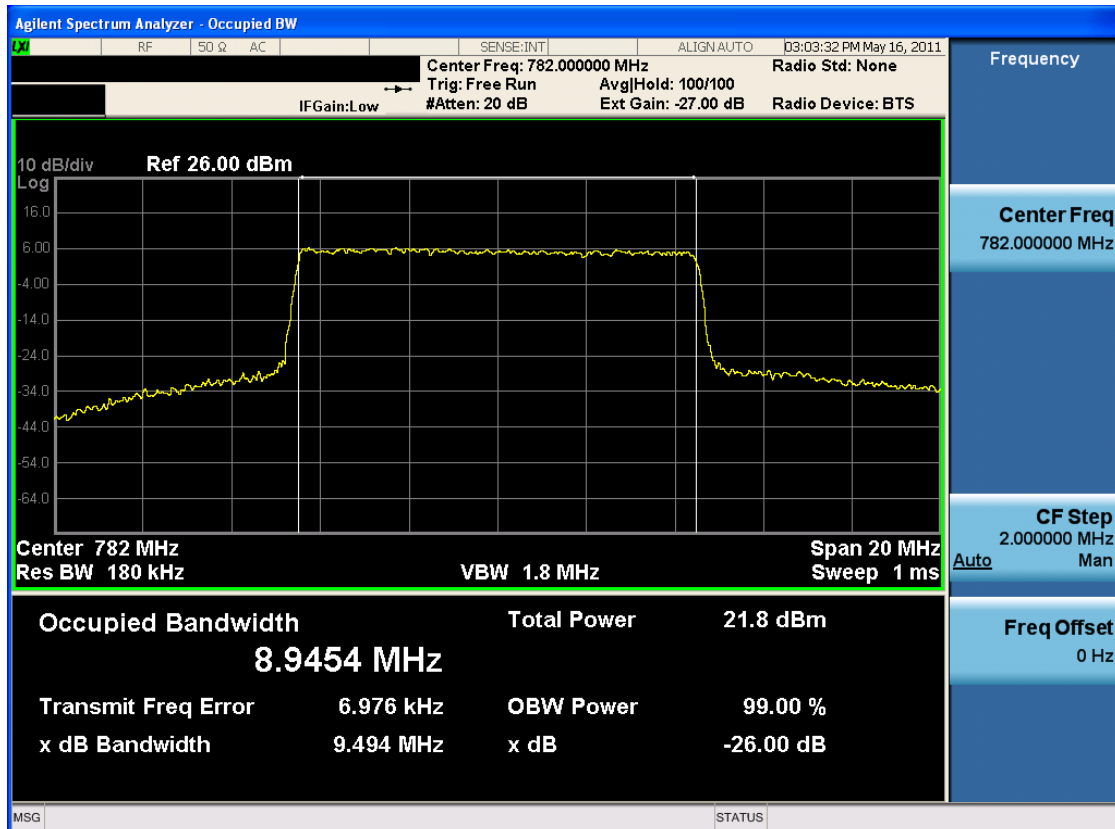

FCC CERTIFICATION REPORT

Test Report No. HCTR1106FR25	Date of Issue: June 16, 2011	EUT Type: CDMA/LTE Phone with Bluetooth & WLAN	FCC ID: JYCAPACHE	Page 24 of 42
---------------------------------	---------------------------------	--	----------------------	---------------

■ Occupied Bandwidth (16-QAM – RB Size 1, RB Offset 0)

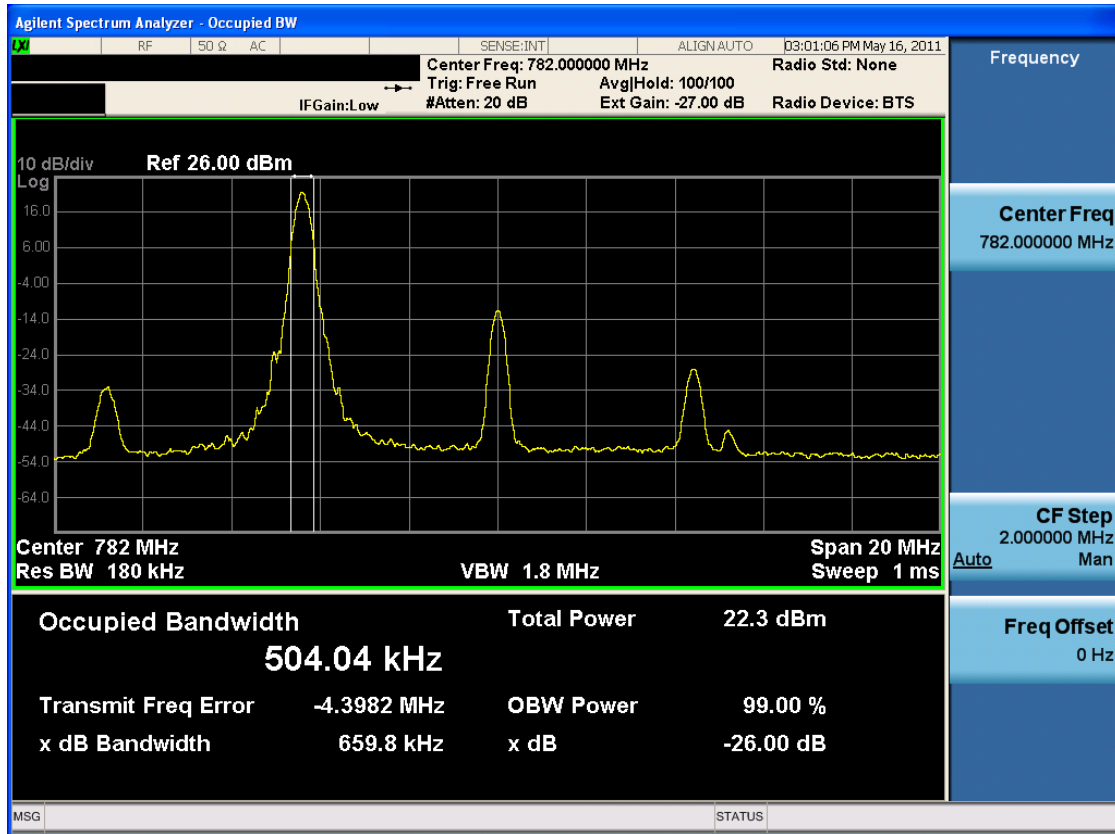

■ Occupied Bandwidth (16-QAM – RB Size 1, RB Offset 49)

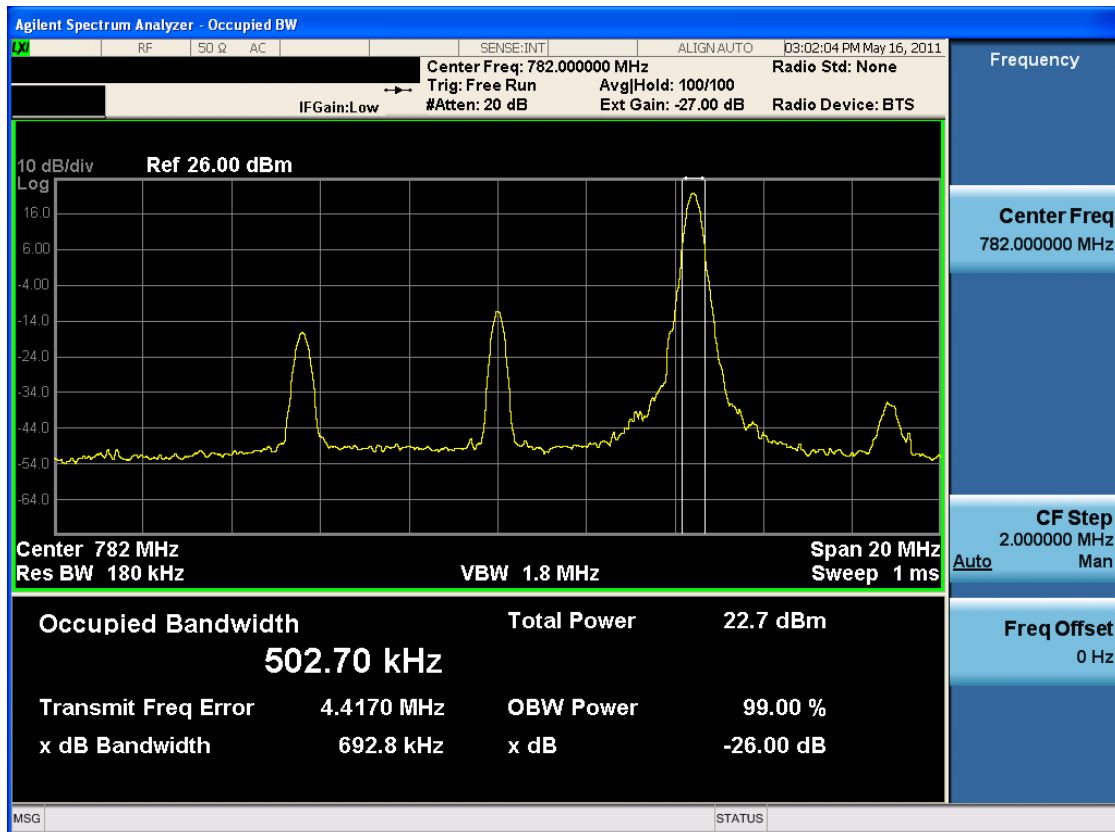

■ Occupied Bandwidth (16-QAM – RB Size 25, RB Offset 12)

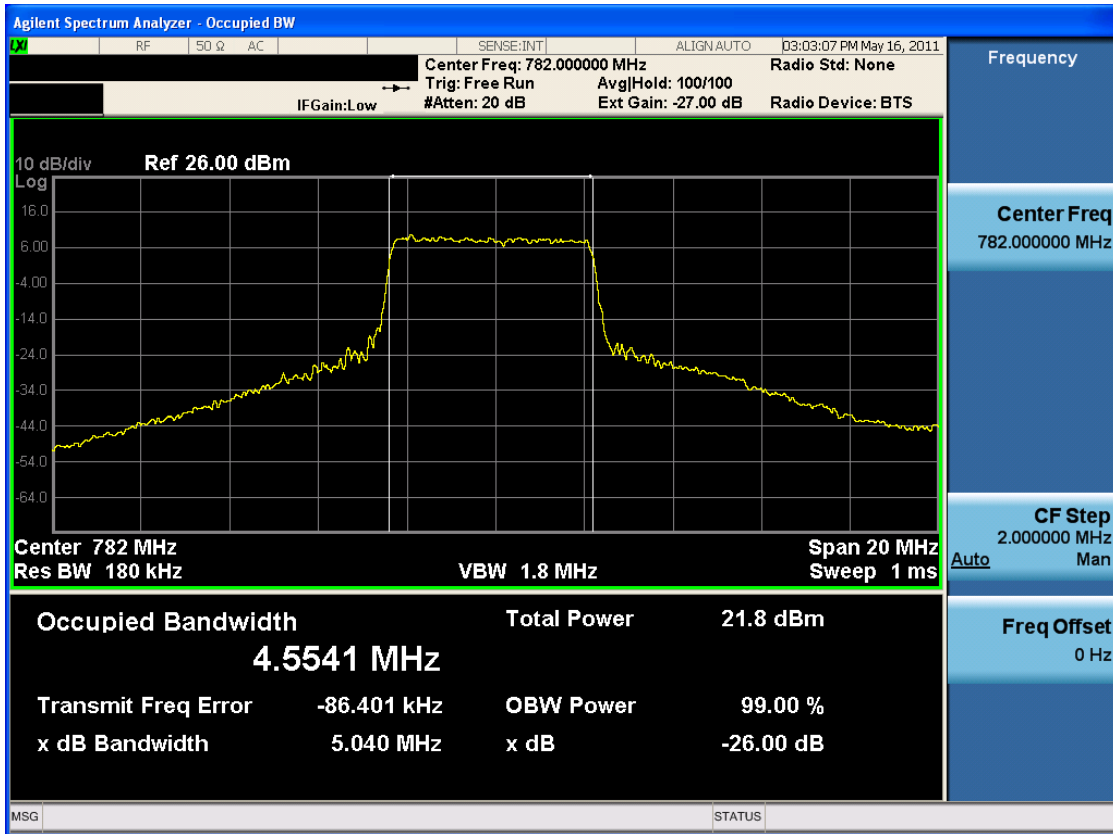

■ Occupied Bandwidth (16-QAM – RB Size 50)

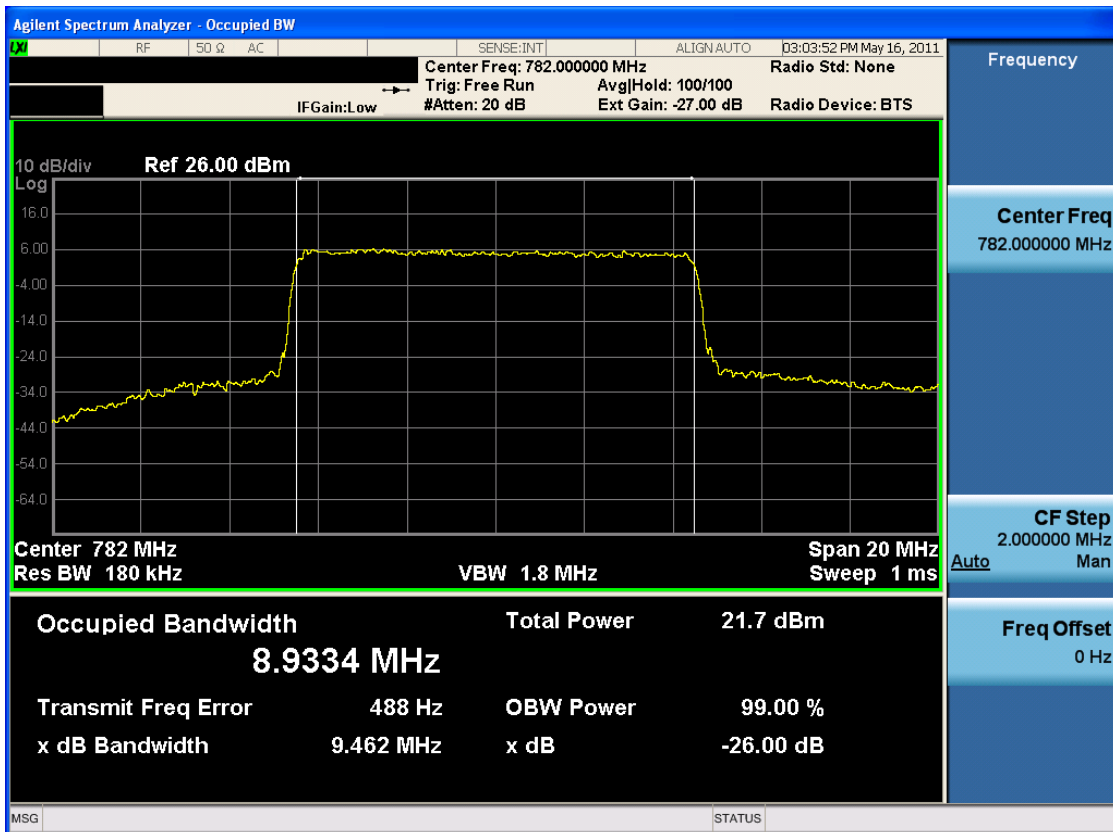

■ Low Band Edg (QPSK – RB Size 1, RB Offset 0)

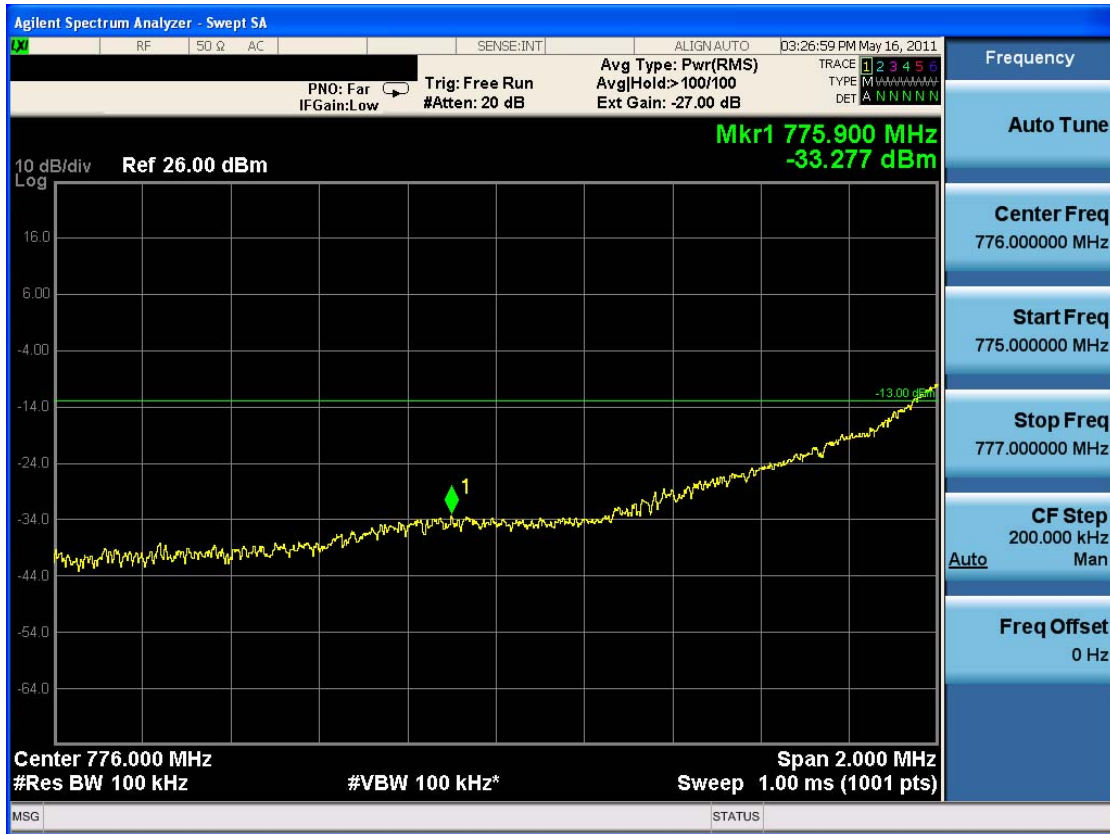

■ Low Band Edg (QPSK – RB Size 50)

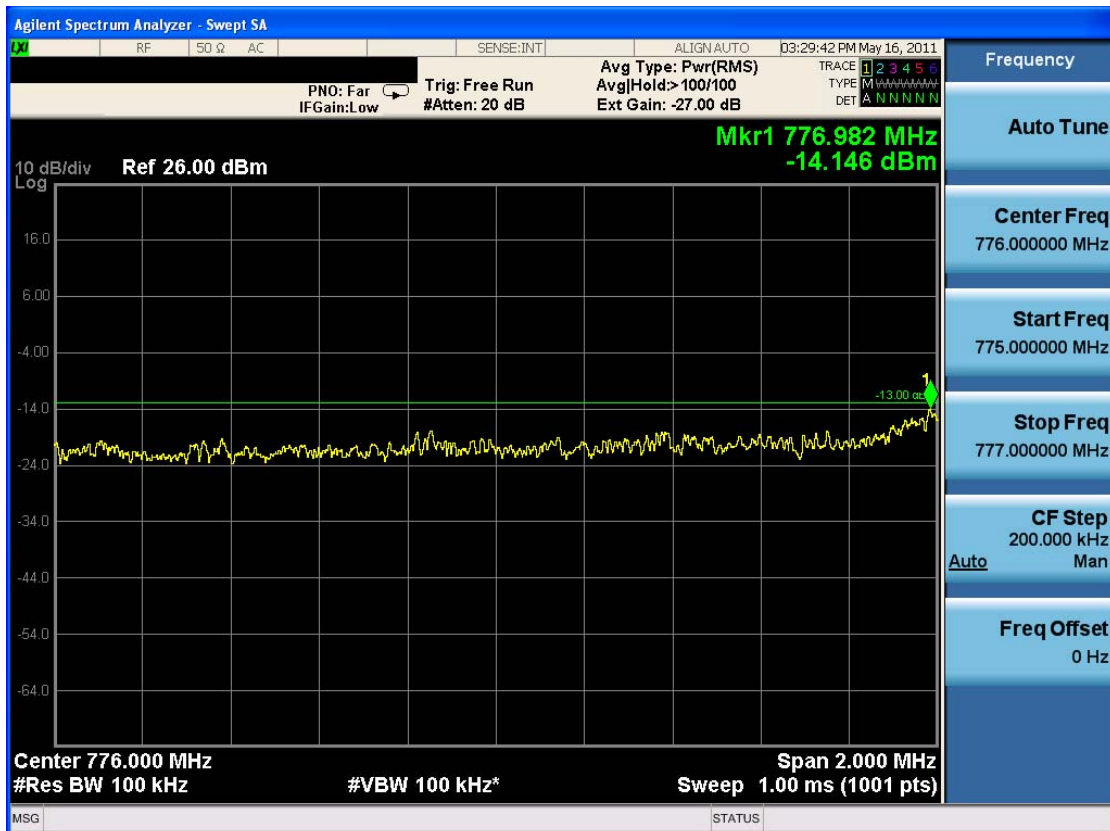

■ Upper Band Edg (QPSK – RB Size 1, RB Offset 49)

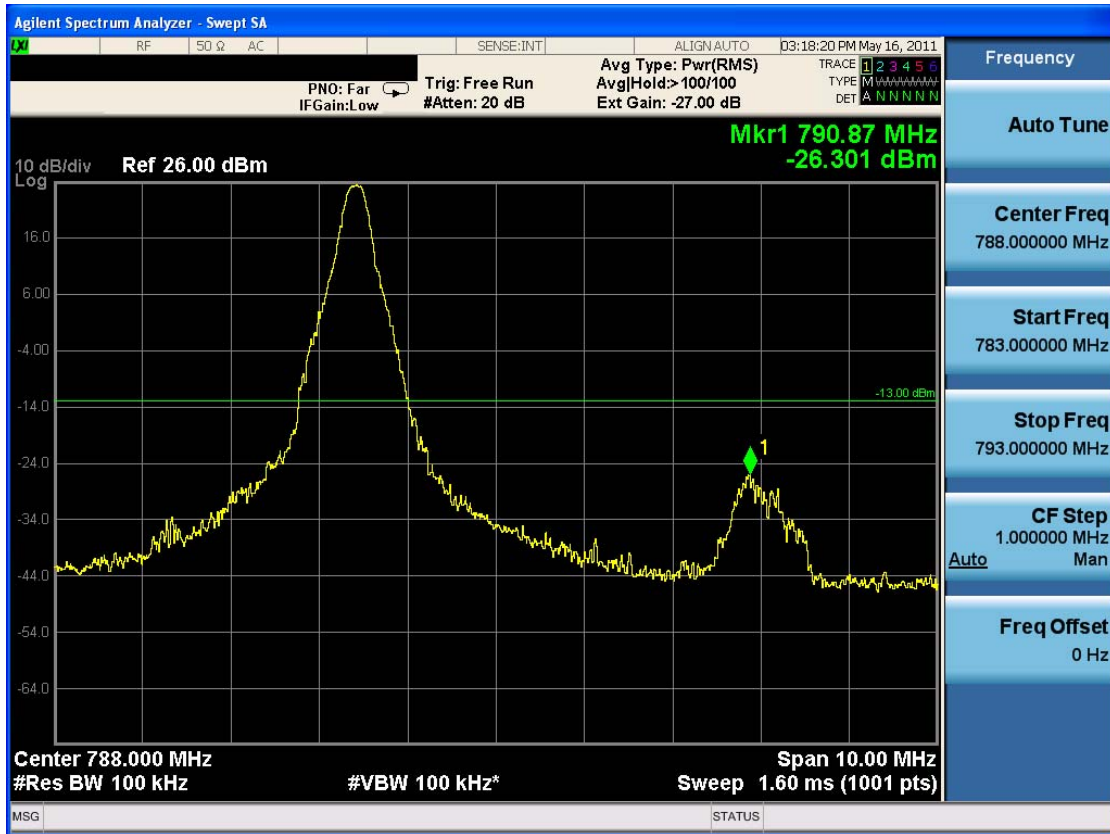

■ Upper Band Edg (QPSK – RB Size 50)

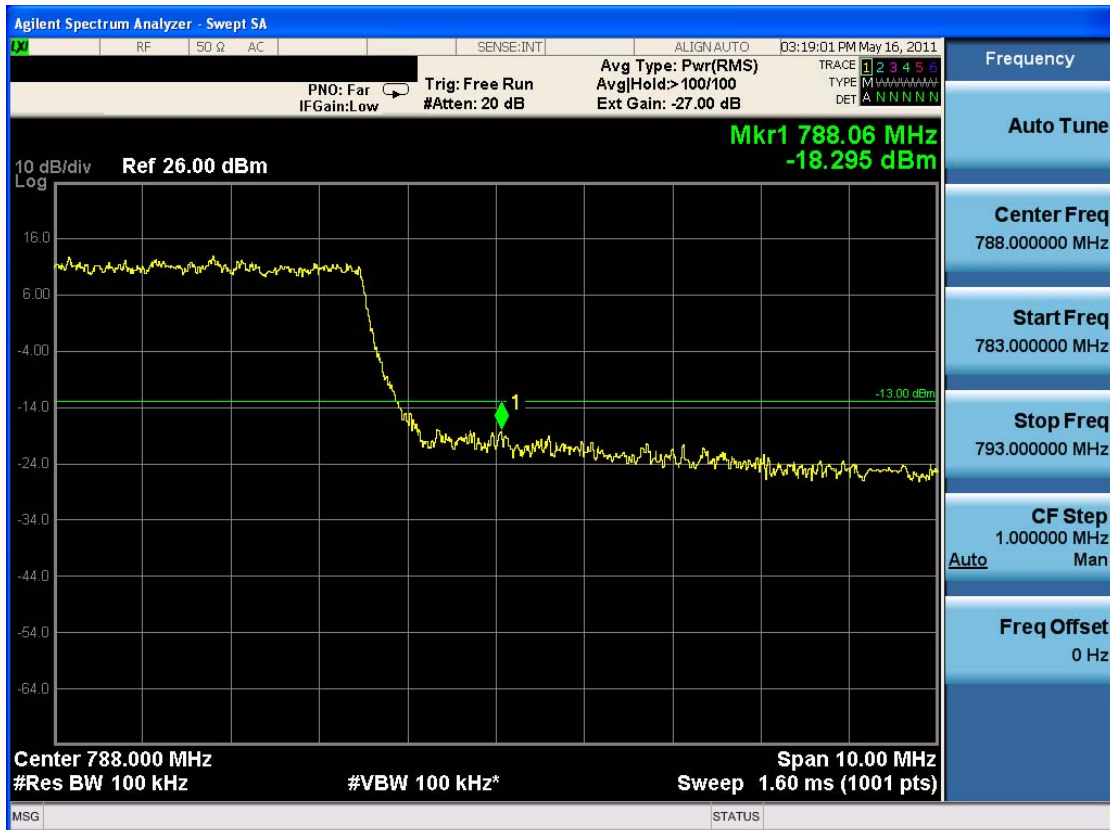

■ Low Band Edg (16-QAM – RB Size 1, RB Offset 0)

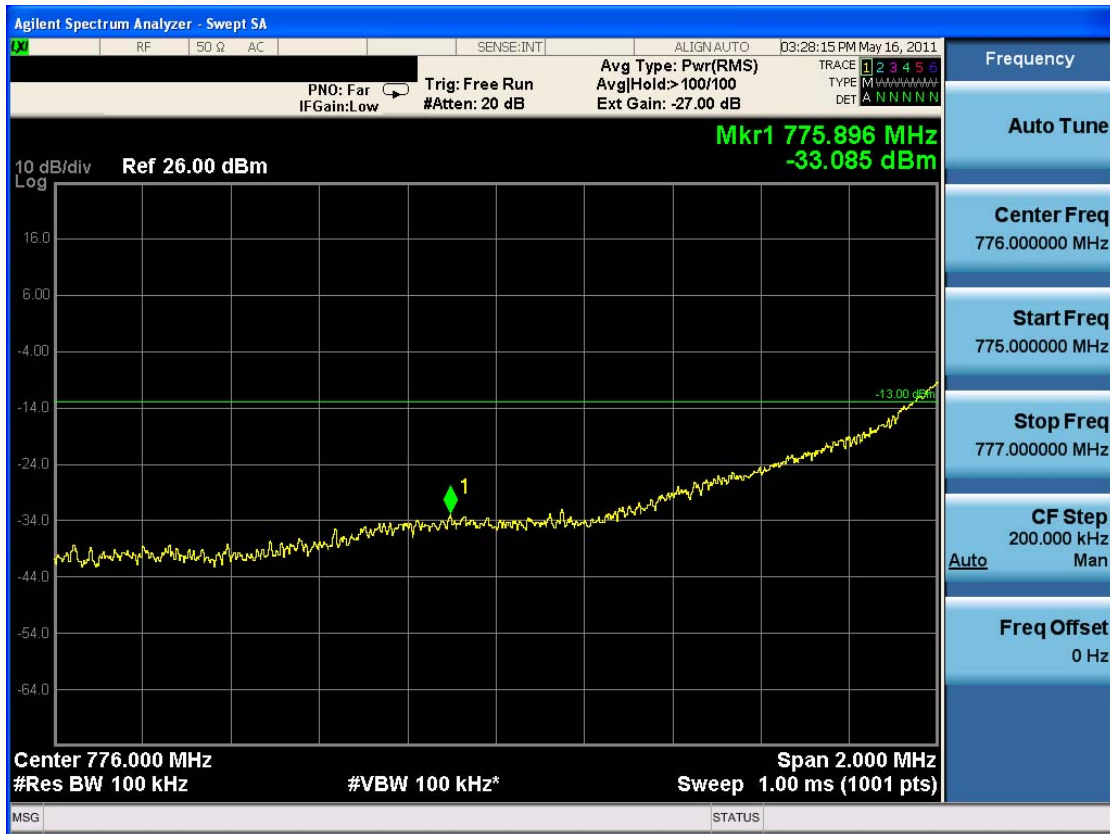

■ Low Band Edg (16-QAM – RB Size 50)

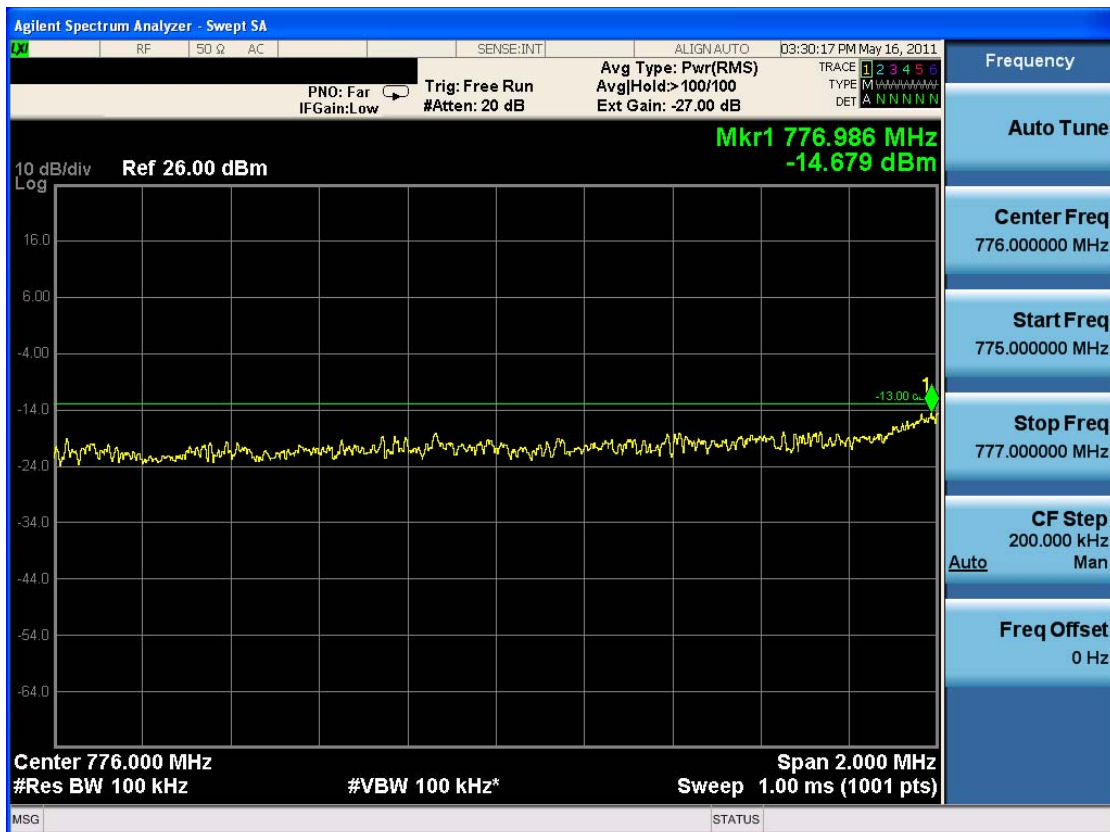

■ Upper Band Edg (16-QAM – RB Size 1, RB Offset 49)

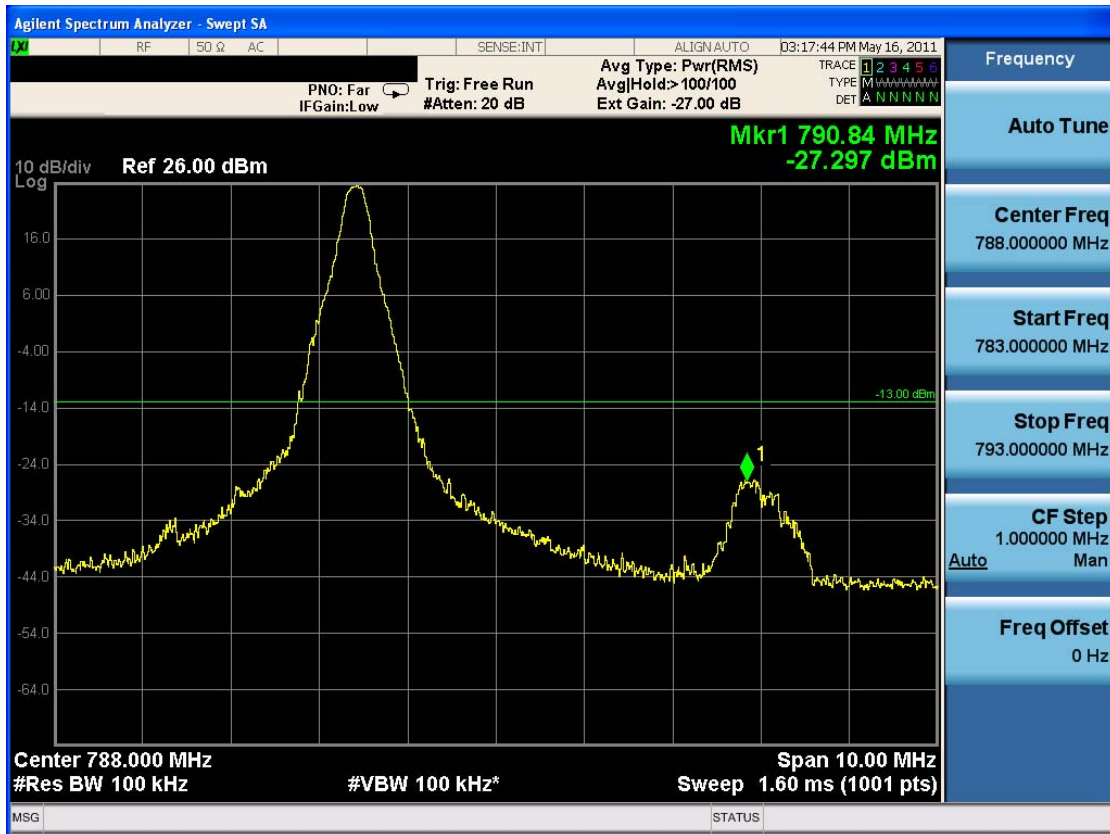

■ Upper Band Edg (16-QAM – RB Size 50)

