



SAR TEST REPORT

HCT CO., LTD



EUT Type:	CDMA/LTE Phone with Bluetooth & WLAN	
FCC ID:	JYCAPACHE	
Model:	ADR8995	
Date of Issue:	June 16, 2011	
Test report No.:	HCTA1106FS05	
Test Laboratory:	HCT CO., LTD. 105-1, Jangam-ri, Majang-myeon, Icheon-si, Gyeonggi-do, Korea 467-811 TEL: +82 31 645 6485 FAX: +82 31 645 6401	
Applicant :	Pantech Co., Ltd. Pantech Building, I-2, DMC, Sangam-dong, Mapo-gu, Seoul, Korea (ZIP :121-792) Tel: 82-2-2030-1319 Fax: 82-2-2030-2500	
Testing has been carried out in accordance with:	RSS-102 Issue 4; Health Canada Safety Code 6 47CFR §2.1093 FCC OET Bulletin 65 (Edition 97-01), Supplement C (Edition 01-01) ANSI/ IEEE C95.1 – 1992 IEEE 1528-2003	
Test result:	The tested device complies with the requirements in respect of all parameters subject to the test. The test results and statements relate only to the items tested. The test report shall not be reproduced except in full, without written approval of the laboratory.	
Signature	 _____ Report prepared by : Young-Soo Jang Test Engineer of SAR Part	 _____ Approved by : Jae-Sang So Manager of SAR Part

Table of Contents

1. INTRODUCTION	3
2. DESCRIPTION OF DEVICE	4
3. DESCRIPTION OF TEST EQUIPMENT	6
3.1 SAR MEASUREMENT SETUP	6
3.3 PROBE CALIBRATION PROCESS	8
3.4 SAM Phantom	1 0
3.5 Device Holder for Transmitters	1 0
3.6 Brain & Muscle Simulating Mixture Characterization	1 1
3.7 SAR TEST EQUIPMENT	1 2
4. SAR MEASUREMENT PROCEDURE	1 3
5. DESCRIPTION OF TEST POSITION	1 4
6. MEASUREMENT UNCERTAINTY	1 6
7. ANSI/ IEEE C95.1 - 1992 RF EXPOSURE LIMITS	1 7
8. SYSTEM VERIFICATION	1 8
9. SAR Testing with IEEE 802.11 a/b/g Transmitters	1 9
10. 3G MEASUREMENT PROCEDURES	2 0
11. SVLTE/SVDO RF Conducted Power	2 3
12. LTE PLOTS	3 4
13. Mobile Hotspot Side for SAR Testing	3 8
14. SAR Evaluation Considerations for Handsets with Multiple Transmitters and Antennas	3 9
15. SAR TEST DATA SUMMARY	4 2
15.1 Measurement Results (CDMA835 Head SAR)	4 2
15.2 Measurement Results (PCS1900 Head SAR)	4 3
15.3 Measurement Results (LTE Head SAR QPSK)	4 4
15.4 Measurement Results (LTE Head SAR 16QAM)	4 5
15.5 Measurement Results (802.11b/g/n Head)	4 6
15.6 Measurement Results (CDMA835 Hotspot SAR)	4 7
15.7 Measurement Results (PCS1900 Hotspot SAR)	4 8
15.8 Measurement Results (802.11b/g/n Hotspot SAR)	4 9
15.9 Measurement Results (LTE Body SAR QPSK)	5 0
15.10 Measurement Results (LTE Body SAR 16QAM)	5 1
16. CONCLUSION	5 2
17. REFERENCES	5 3
Attachment 1. – SAR Test Plots	5 4
Attachment 2. – Dipole Validation Plots	1 6 4
Attachment 3. – Probe Calibration Data	1 8 1
Attachment 4. – Dipole Calibration Data	1 9 3

1. INTRODUCTION

The FCC has adopted the guidelines for evaluating the environmental effects of radio frequency radiation in ET Docket 93-62 on Aug. 6, 1996 to protect the public and workers from the potential hazards of RF emissions due to FCC-regulated portable devices.

The safety limits used for the environmental evaluation measurements are based on the criteria published by the American National Standards Institute (ANSI) for localized specific absorption rate (SAR) in IEEE/ANSI C95.1-1992 Standard for Safety Levels with Respect to Human Exposure to Radio Frequency Electromagnetic Fields, 3 kHz to 300 GHz. 1992 by the Institute of Electrical and Electronics Engineers, Inc., New York, New York 10017. The measurement procedure described in IEEE/ANSI C95.3-1992 Recommended Practice for the Measurement of Potentially Hazardous Electromagnetic Fields - RF and Microwave is used for guidance in measuring SAR due to the RF radiation exposure from the Equipment Under Test (EUT). These criteria for SAR evaluation are similar to those recommended by the National Council on Radiation Protection and Measurements (NCRP) in Biological Effects and Exposure Criteria for Radio frequency Electromagnetic Fields," NCRP Report No. 86 NCRP, 1986, Bethesda, MD 20814. SAR is a measure of the rate of energy absorption due to exposure to an RF transmitting source. SAR values have been related to threshold levels for potential biological hazards.

SAR Definition

Specific Absorption Rate (SAR) is defined as the time derivative of the incremental electromagnetic energy (dW) absorbed by (dissipated in) an incremental mass (dm) contained in a volume element (dV) of a given density (ρ). It is also defined as the rate of RF energy absorption per unit mass at a point in an absorbing body.

$$SAR = \frac{d}{dt} \left(\frac{dU}{dm} \right) = \frac{d}{dt} \left(\frac{dU}{\rho dV} \right)$$

Figure 2. SAR Mathematical Equation

SAR is expressed in units of Watts per Kilogram (W/kg).

where:

$$SAR = \sigma E^2 / \rho$$

σ = conductivity of the tissue-simulant material (S/m)
 ρ = mass density of the tissue-simulant material (kg/m³)
 E = Total RMS electric field strength (V/m)

NOTE: The primary factors that control rate of energy absorption were found to be the wavelength of the incident field in relations to the dimensions and geometry of the irradiated organism, the orientation of the organism in relation to the polarity of field vectors, the presence of reflecting surfaces, and whether conductive contact is made by the organism with a ground plane.

2. DESCRIPTION OF DEVICE

Environmental evaluation measurements of specific absorption rate (SAR) distributions in emulated human head and body tissues exposed to radio frequency (RF) radiation from wireless portable devices for compliance with the rules and regulations of the U.S. Federal Communications Commission (FCC).

EUT Type	CDMA/LTE Phone with Bluetooth & WLAN		
FCC ID:	JYCAPACHE		
Model:	ADR8995		
Trade Name	Pantech	Serial Number(s)	#1
Application Type	Certification		
Mode(s) of Operation	CDMA835/PCS1900 /802.11b/g/n//LTE Band13		
Tx Frequency	824.70 - 848.31 MHz (CDMA835)/ 1 851.25 – 1 908.75 MHz (PCS CDMA) 2 412- 2 462 MHz (WLAN) /777 – 787 MHz (LTE)		
Rx Frequency	869.70 - 893.31 MHz (CDMA) /1 931.25 – 1 988.75 MHz (PCS CDMA) 2 412- 2 462 MHz (WLAN)/ 746 – 756 MHz (LTE)		
FCC Classification	Licensed Portable Transmitter Held to Ear (PCE)		
Production Unit or Identical Prototype	Prototype		
Max SAR	0.598 W/kg CDMA835 Head SAR / 0.670 W/kg CDMA835 Body SAR 1.05 W/kg PCS1900 Head SAR /0.797 W/kg PCS1900 Body SAR 0.261 W/kg Wi-Fi 802.11b Head SAR / 0.089 W/kg Wi-Fi 802.11b Body SAR 0.321 W/kg LTE Head SAR /0.442 W/kg LTE Body SAR		
Date(s) of Tests	May 6, 2011, May 9, 2011/June 8, 2011 ~ June 10, 2011		
Antenna Type	Intenna		

Characteristics and Capabilities for LTE

UE Category	3
Power Class	UE Power Class 3
Modulation	QPSK/16QAM
Channel Band width	10 MHz
Frequency Band	3GPP Band 13, UL(777MHz-787MHz), DL(746MHz-756MHz)
Voice & Data mode	Data Only
Reference	June 2010 Verizon Requirements, 3GPP TS 36.101 v9.4.0

Note;

WiFi Hotspot : There is no power back-off capability in this device.

Power tolerance: Maximum Output Power +/- 0.5 dB

- UE Category: The field UE Category defines a combined uplink and downlink capability.

UE Category	Peak Data Rate (Mbps)	
	DL	UL
1	10	5
2	50	25
3	100	50
4	150	50
5	300	75

3. DESCRIPTION OF TEST EQUIPMENT

3.1 SAR MEASUREMENT SETUP

These measurements are performed using the DASY4 automated dosimetric assessment system. It is made by Schmid & Partner Engineering AG (SPEAG) in Zurich, Switzerland. It consists of high precision robotics system (Staubli), robot controller, Pentium III computer, near-field probe, probe alignment sensor, and the generic twin phantom containing the brain equivalent material. The robot is a six-axis industrial robot performing precise movements to position the probe to the location (points) of mMaximum electromagnetic field (EMF) (see Figure.3.1).

A cell controller system contains the power supply, robot controller, teach pendant (Joystick), and remote control, is used to drive the robot motors. The PC consists of the HP Pentium IV 3.0 GHz computer with Windows XP system and SAR Measurement Software DASY4, A/D interface card, monitor, mouse, and keyboard. The Staubli Robot is connected to the cell controller to allow software manipulation of the robot. A data acquisition electronic (DAE) circuit performs the signal amplification, signal multiplexing, AD-conversion, offset measurements, mechanical surface detection, collision detection, etc. is connected to the Electro-optical coupler (EOC). The EOC performs the conversion from the optical into digital electric signal of the DAE and transfers data to the PC plug-in card.

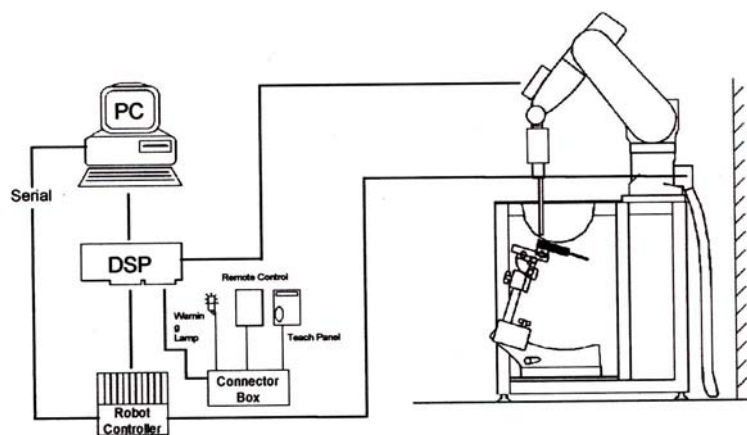

Figure 3.1 HCT SAR Lab. Test Measurement Set-up

The DAE4 consists of a highly sensitive electrometer-grade preamplifier with auto-zeroing, a channel and gain-switching multiplexer, a fast 16 bit AD-converter and a command decoder and control logic unit. Transmission to the PC-card is accomplished through an optical downlink for data and status information and an optical uplink for commands and clock lines. The mechanical probe mounting device includes two different sensor systems for frontal and sidewise probe contacts. They are also used for mechanical surface detection and probe collision detection. The robot uses its own controller with a built in VME-bus computer. The system is described in detail in.

3.2 DASYS4 E-FIELD PROBE SYSTEM

3.1 ES3DV3 Probe Specification

Construction	Symmetrical design with triangular core Interleaved sensors Built-in shielding against static charges PEEK enclosure material (resistant to organic solvents, e.g., DGBE)
Calibration	Basic Broad Band Calibration in air Conversion Factors (CF) for HSL 900 and HSL 1810 Additional CF for other liquids and frequencies upon request
Frequency	10 MHz to 4 GHz; Linearity: ± 0.2 dB (30 MHz to 4 GHz)
Directivity	± 0.2 dB in HSL (rotation around probe axis) ± 0.3 dB in tissue material (rotation normal to probe axis)
Dynamic Range	5 μ W/g to > 100 mW/g; Linearity: ± 0.2 dB
Dimensions	Overall length: 330 mm (Tip: 20 mm) Tip diameter: 3.9 mm (Body: 12 mm) Distance from probe tip to dipole centers: 2.0 mm
Application	General dosimetry up to 4 GHz Dosimetry in strong gradient fields Compliance tests of mobile phones

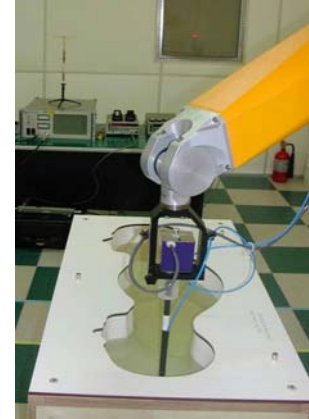

Figure 3.1 Photograph of the probe and the Phantom



Figure 3.2 ES3DV3 E-field Probe

The SAR measurements were conducted with the dosimetric probe ES3DV3, designed in the classical triangular configuration and optimized for dosimetric evaluation. The probe is constructed using the thick film technique; with printed resistive lines on ceramic substrates. The probe is equipped with an optical multifiber line ending at the front of the probe tip. It is connected to the EOC box on the robot arm and provides an automatic detection of the phantom surface. Half of the fibers are connected to a pulsed infrared transmitter, the other half to a synchronized receiver. As the probe approaches the surface, the reflection from the surface produces a coupling from the transmitting to the receiving fibers. This reflection increases first during the approach, reaches a mMaximum and then decreases. If the probe is flatly touching the surface, the coupling is zero. The distance of the coupling mMaximum to the surface is independent of the surface reflectivity and largely independent of the surface to probe angle. The DASYS4 software reads the reflection during a software approach and looks for the mMaximum using a 2nd order fitting. The approach is stopped at reaching the mMaximum.

3.3 PROBE CALIBRATION PROCESS

3.3.1 E-Probe Calibration

Each probe is calibrated according to a dosimetric assessment procedure with an accuracy better than $\pm 10\%$. The spherical isotropy was evaluated with the proper procedure and found to be better than ± 0.25 dB. The sensitivity parameters (NormX, NormY, NormZ), the diode compression parameter (DCP) and the conversion factor (ConvF) of the probe is tested.

The free space E-field from amplified probe outputs is determined in a test chamber. This is performed in a TEM cell for frequencies below 1 GHz, and in a waveguide above 1 GHz for free space. For the free space calibration, the probe is placed in the volumetric center of the cavity and at the proper orientation with the field. The probe is then rotated 360 degrees.

E-field temperature correlation calibration is performed in a flat phantom filled with the appropriate simulated brain tissue. The measured free space E-field in the medium correlates to temperature rise in a dielectric medium. For temperature correlation calibration a RF transparent thermistor-based temperature probe is used in conjunction with the E-field probe.

$$SAR = C \frac{\Delta T}{\Delta t}$$

where:

- Δt = exposure time (30 seconds),
- C = heat capacity of tissue (brain or muscle),
- ΔT = temperature increase due to RF exposure.

SAR is proportional to $\Delta T / \Delta t$, the initial rate of tissue heating, before thermal diffusion takes place. Now it's possible to quantify the electric field in the simulated tissue by equating the thermally derived SAR to the E- field;

$$SAR = \frac{|E|^2 \cdot \sigma}{\rho}$$

where:

- σ = simulated tissue conductivity,
- ρ = Tissue density (1.25 g/cm³ for brain tissue)

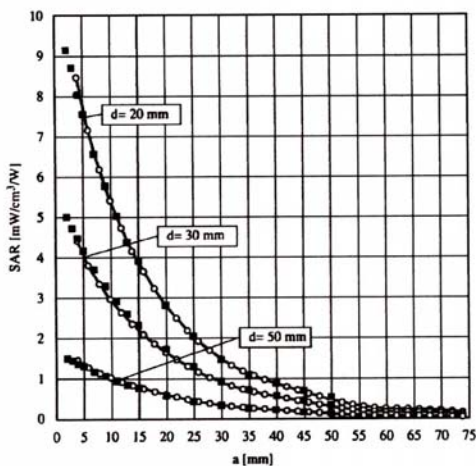

Figure 3.4 E-Field and Temperature measurements at 900 MHz

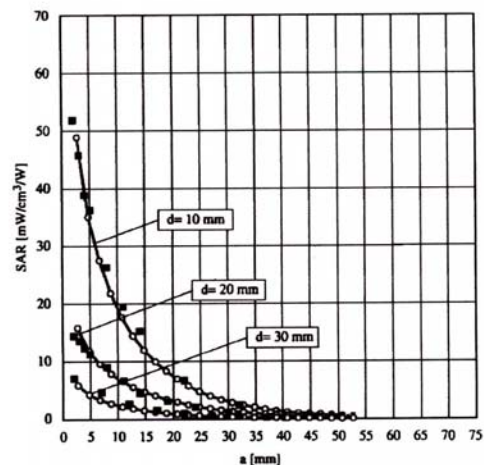

Figure 3.5 E-Field and temperature measurements at 1.8 GHz

3.3.2 Data Extrapolation

The DASY4 software automatically executes the following procedures to calculate the field units from the microvolt readings at the probe connector. The first step of the evaluation is a linearization of the filtered input signal to account for the compression characteristics of the detector diode. The compensation depends on the input signal, the diode type and the DC-transmission factor from the diode to the evaluation electronics. If the exciting field is pulsed, the crest factor of the signal must be known to correctly compensate for peak power. The formula for each channel can be given like below;

$$V_i = U_i + U_i^2 \cdot \frac{cf}{dcp_i}$$

with V_i = compensated signal of channel i (i=x,y,z)
 U_i = input signal of channel i (i=x,y,z)
 cf = crest factor of exciting field (DASY parameter)
 dcp_i = diode compression point (DASY parameter)

From the compensated input signals the primary field data for each channel can be evaluated:

E-field probes:

$$E_i = \sqrt{\frac{V_i}{Norm_i \cdot ConvF}}$$

with V_i = compensated signal of channel i (i = x,y,z)
 $Norm_i$ = sensor sensitivity of channel i (i = x,y,z)
 $\mu V/(V/m)^2$ for E-field probes
 $ConvF$ = sensitivity of enhancement in solution
 E_i = electric field strength of channel i in V/m

The RSS value of the field components gives the total field strength (Hermetian magnitude):

$$E_{tot} = \sqrt{E_x^2 + E_y^2 + E_z^2}$$

The primary field data are used to calculate the derived field units.

$$SAR = E_{tot}^2 \cdot \frac{\sigma}{\rho \cdot 1000}$$

with SAR = local specific absorption rate in W/g
 E_{tot} = total field strength in V/m
 σ = conductivity in [mho/m] or [Siemens/m]
 ρ = equivalent tissue density in g/cm³

The power flow density is calculated assuming the excitation field to be a free space field.

$$P_{pwe} = \frac{E_{tot}^2}{3770}$$

with P_{pwe} = equivalent power density of a plane wave in W/cm²
 E_{tot} = total electric field strength in V/m

3.4 SAM Phantom

The shell corresponds to the specifications of the Specific Anthropomorphic Mannequin (SAM) phantom defined in IEEE 1528 and IEC 62209-1. It enables the dosimetric evaluation of left and right hand phone usage as well as body mounted usage at the flat phantom region. A cover prevents evaporation of the liquid. Reference markings on the phantom allow the complete setup of all predefined phantom positions and measurement grids by teaching three points with the robot.



Figure 3.6 SAM Phantom

Shell Thickness	2.0 mm
Filling Volume	about 25 L
Dimensions	1 000 mm x 500 mm (L x W)

3.5 Device Holder for Transmitters

In combination with the SAM Phantom V 4.0, the Mounting Device (POM) enables the rotation of the mounted transmitter in spherical coordinates whereby the rotation points is the ear opening. The devices can be easily, accurately, and repeatably positioned according to the FCC and CENELEC specifications. The device holder can be locked at different phantom locations (left head, right head, flat phantom).

Note: A simulating human hand is not used due to the complex anatomical and geometrical structure of the hand that may produce an infinite number of configurations. To produce the Worst-case condition (the hand absorbs antenna output power), the hand is omitted during the tests.



Figure 3.7 Device Holder

3.6 Brain & Muscle Simulating Mixture Characterization

The brain and muscle mixtures consist of a viscous gel using hydrox-ethyl cellulose (HEC) gelling agent and saline solution (see Table 3.1). Preservation with a bactericide is added and visual inspection is made to make sure air bubbles are not trapped during the mixing process. The mixture is calibrated to obtain proper dielectric constant (permittivity) and conductivity of the desired tissue. The mixture characterizations used for the brain and muscle tissue simulating liquids are according to the data by C. Gabriel and G. Hartsgrove.

Ingredients (% by weight)	Frequency (MHz)											
	450		750		835		915		1 900		2 450	
Tissue Type	Head	Body	Head	Body	Head	Body	Head	Body	Head	Body	Head	Body
Water	38.56	51.16	41.2	51.7	41.45	52.4	41.05	56.0	54.9	40.4	62.7	73.2
Salt (NaCl)	3.95	1.49	1.4	1.0	1.45	1.4	1.35	0.76	0.18	0.5	0.5	0.04
Sugar	56.32	46.78	57	47.2	56.0	45.0	56.5	41.76	0.0	58.0	0.0	0.0
HEC	0.98	0.52	0.2	0.0	1.0	1.0	1.0	1.21	0.0	1.0	0.0	0.0
Bactericide	0.19	0.05	0.2	0.1	0.1	0.1	0.1	0.27	0.0	0.1	0.0	0.0
Triton X-100	0.0	0.0	0.00	0.0	0.0	0.0	0.0	0.0	0.0	0.0	36.8	0.0
DGBE	0.0	0.0	0.00	0.0	0.0	0.0	0.0	0.0	44.92	0.0	0.0	26.7

Salt:	99 % Pure Sodium Chloride	Sugar:	98 % Pure Sucrose
Water:	De-ionized, 16M resistivity	HEC:	Hydroxyethyl Cellulose
DGBE:	99 % Di(ethylene glycol) butyl ether,[2-(2-butoxyethoxy) ethanol]		
Triton X-100(ultra pure):	Polyethylene glycol mono[4-(1,1,3,3-tetramethylbutyl)phenyl] ether		

Table 3.1 Composition of the Tissue Equivalent Matter

3.7 SAR TEST EQUIPMENT

Manufacturer	Type / Model	S/N	Calib. Date	Calib.Interval	Calib.Due
SPEAG	SAM Phantom	-	N/A	N/A	N/A
Staubli	Robot RX90L	F01/5K09A1/A/01	N/A	N/A	N/A
Staubli	Robot ControllerCS7MB	F99/5A82A1/C/01	N/A	N/A	N/A
HP	Pavilion t000_puffer	KRJ51201TV	N/A	N/A	N/A
SPEAG	Light Alignment Sensor	265	N/A	N/A	N/A
Staubli	Teach Pendant (Joystick)	D221340.01	N/A	N/A	N/A
SPEAG	DAE3	466	Mar. 1, 2011	Annual	Mar. 1, 2012
SPEAG	E-Field Probe ES3DV3	3161	Mar. 17, 2011	Annual	Mar. 17, 2012
SPEAG	Validation Dipole D835V2	441	May 16, 2011	Annual	May 16, 2012
SPEAG	Validation Dipole D750V3	1014	July 21, 2010	Annual	July 21, 2011
SPEAG	Validation Dipole D1900V2	5d032	July 16, 2010	Annual	July 16, 2011
SPEAG	Validation Dipole D2450V2	743	Aug. 25, 2010	Annual	Aug. 25, 2011
Agilent	Power Meter(F) E4419B	MY41291386	Nov. 05, 2010	Annual	Nov. 05, 2011
Agilent	Power Sensor(G) 8481	MY41090870	Nov. 05, 2010	Annual	Nov. 05, 2011
HP	Dielectric Probe Kit 85070C	00721521	N/A	N/A	N/A
HP	Dual Directional Coupler	16072	Nov. 05, 2010	Annual	Nov. 05, 2011
R&S	Base Station CMU200	110740	July 26, 2010	Annual	July 26, 2011
Agilent	Base Station E5515C	GB44400269	Feb. 10, 2011	Annual	Feb. 10, 2012
HP	Signal Generator E4438C	MY42082646	Nov. 11, 2010	Annual	Nov. 11, 2011
HP	Network Analyzer 8753ES	JP39240221	Mar. 30, 2011	Annual	Mar. 30, 2012
R&S	Base Station CMW500	101901	Aug.5, 2010	Annual	Aug.5, 2011

NOTE:

The E-field probe was calibrated by SPEAG, by the waveguide technique procedure. Dipole Validation measurement is performed by HCT Lab. before each test. The brain simulating material is calibrated by HCT using the dielectric probe system and network analyzer to determine the conductivity and permittivity (dielectric constant) of the brain-equivalent material.

4. SAR MEASUREMENT PROCEDURE

The evaluation was performed with the following procedure:

1. The SAR value at a fixed location above the ear point was measured and was used as a reference value for assessing the power drop.
2. The SAR distribution at the exposed side of the head was measured at a distance of 3.9 mm from the inner surface of the shell. The area covered the entire dimension of the head and the horizontal grid spacing was 20 mm x 20 mm. Based on this data, the area of the mMaximum absorption was determined by spline interpolation.
3. Around this point, a volume of 32 mm x 32 mm x 30 mm was assessed by measuring 5 x 5 x 7 points. On this basis of this data set, the spatial peak SAR value was evaluated with the following procedure:
 - a. The data at the surface were extrapolated, since the center of the dipoles is 2.7 mm away from the tip of the probe and the distance between the surface and the lowest measuring point is 1.2 mm. The extrapolation was based on a least square algorithm. A polynomial of the fourth order was calculated through the points in z-axes. This polynomial was then used to evaluate the points between the surface and the probe tip.
 - b. The mMaximum interpolated value was searched with a straight-forward algorithm. Around this mMaximum the SAR values averaged over the spatial volumes (1 g or 10 g) were computed using the 3D-Spline interpolation algorithm. The 3D-spline is composed of three one-dimensional splines with the "Not a knot" condition (in x, y, and z directions. The volume was integrated with the trapezoidal algorithm. One thousand points (10 x 10 x 10) were interpolated to calculate the average.
 - c. All neighboring volumes were evaluated until no neighboring volume with a higher average value was found.
4. The SAR value, at the same location as procedure #1, was re-measured. If the value changed by more than 5 %, the evaluation is repeated.

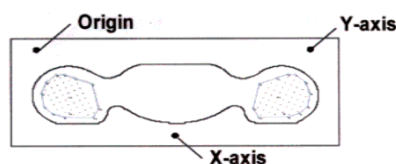

Figure 4.1 SAR Measurement Point in Area Scan

5. DESCRIPTION OF TEST POSITION

5.1 HEAD POSITION

The device was placed in a normal operating position with the Point A on the device, as illustrated in following drawing, aligned with the location of the RE(ERP) on the phantom. With the ear-piece pressed against the head, the vertical center line of the body of the handset was aligned with an imaginary plane consisting of the RE, LE and M. While maintaining these alignments, the body of the handset was gradually moved towards the cheek until any point on the mouth-piece or keypad contacted the cheek. This is a cheek/touch position. For ear/tilt position, while maintain the device aligned with the BM and FN lines, the device was pivot against ERP back for 15° or until the device antenna touch the phantom. Please refer to IEEE 1528-2003 illustration below.

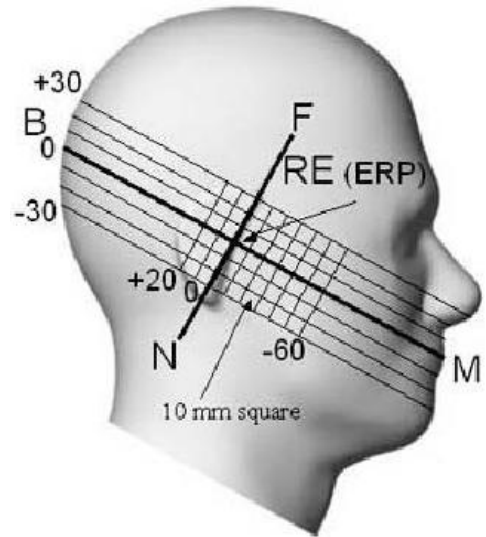

Figure 5.1 Side view of the phantom

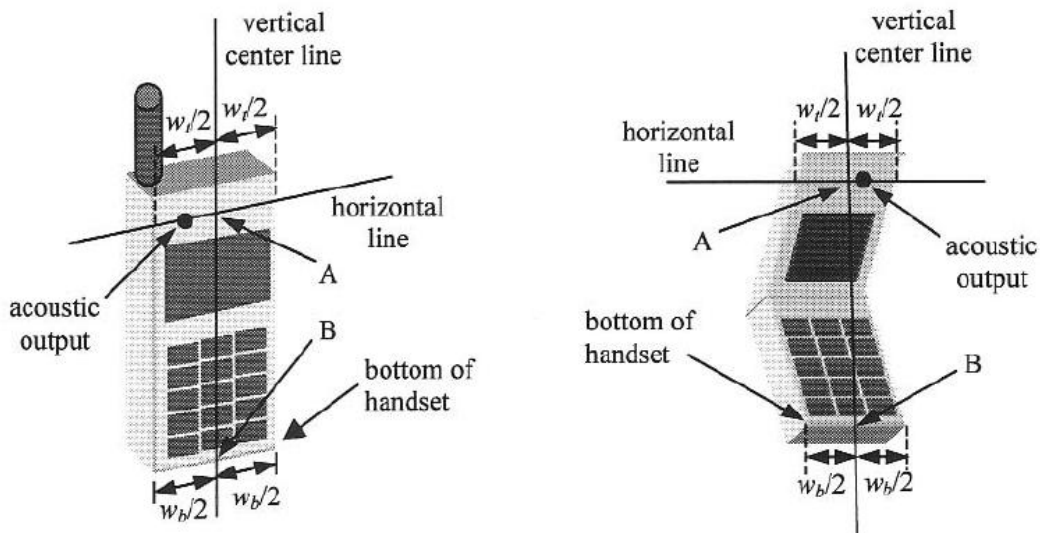

Figure 5.2 Handset vertical and horizontal reference lines

5.2 Body Holster/Belt Clip Configurations

Body-worn operating configurations are tested with the belt-clips and holsters attached to the device and positioned against a flat phantom in a normal use configuration. A device with a headset output is tested with a headset connected to the device. Body dielectric parameters are used.

Accessories for Body-worn operation configurations are divided into two categories: those that do not contain metallic components and those that contain metallic components. When multiple accessories that do not contain metallic components are supplied with the device, the device is tested with only the accessory that dictates the closest spacing to the body. Then multiple accessories that contain metallic components are tested with each accessory. If multiple accessory share an identical metallic component (i.e. the same metallic belt-clip used with different holsters with no other metallic components) only the accessory that dictates the closest spacing to the body is tested.

Body-worn accessories may not always be supplied or available as options for some Devices intended to be authorized for body-worn use. In this case, a test configuration with a separation distance between the back of the device and the flat phantom is used.

Since this EUT does not supply any body worn accessory to the end user a distance of 1.0 cm from the EUT back surface to the liquid interface is configured for the generic test.

"See the Test SET-UP Photo"

Transmitters that are designed to operate in front of a person's face, as in push-to-talk configurations, are tested for SAR compliance with the front of the device positioned to face the flat phantom. For devices that are carried next to the body such as a shoulder, waist or chest-worn transmitters, SAR compliance is tested with the accessory(ies), including headsets and microphones, attached to the device and positioned against a flat phantom in a normal use configuration.

In all cases SAR measurements are performed to investigate the worst-case positioning. Worstcase positioning is then documented and used to perform Body SAR testing.

6. MEASUREMENT UNCERTAINTY

Error Description	Tol (± %)	Prob. dist.	Div.	c_i	Standard Uncertainty (± %)	v_{eff}
1. Measurement System						
Probe Calibration	6.00	N	1	1	6.00	∞
Axial Isotropy	4.70	R	1.73	0.7	1.90	∞
Hemispherical Isotropy	9.60	R	1.73	0.7	3.88	∞
Boundary Effects	1.00	R	1.73	1	0.58	∞
Linearity	4.70	R	1.73	1	2.71	∞
System Detection Limits	1.00	R	1.73	1	0.58	∞
Readout Electronics	0.30	N	1.00	1	0.30	∞
Response Time	0.8	R	1.73	1	0.46	∞
Integration Time	2.6	R	1.73	1	1.50	∞
RF Ambient Conditions	3.00	R	1.73	1	1.73	∞
Probe Positioner	0.40	R	1.73	1	0.23	∞
Probe Positioning	2.90	R	1.73	1	1.67	∞
Max SAR Eval	1.00	R	1.73	1	0.58	∞
2. Test Sample Related						
Device Positioning	2.90	N	1.00	1	2.90	145
Device Holder	3.60	N	1.00	1	3.60	5
Power Drift	5.00	R	1.73	1	2.89	∞
3. Phantom and Setup						
Phantom Uncertainty	4.00	R	1.73	1	2.31	∞
Liquid Conductivity(target)	5.00	R	1.73	0.64	1.85	∞
Liquid Conductivity(meas.)	2.07	N	1	0.64	1.32	9
Liquid Permittivity(target)	5.00	R	1.73	0.6	1.73	∞
Liquid Permittivity(meas.)	5.02	N	1	0.6	3.01	9
Combine Standard Uncertainty					11.13	
Coverage Factor for 95 %					$k = 2$	
Expanded STD Uncertainty					22.25	

Table 6.1 Uncertainty (750 MHz- 2600 MHz)

7. ANSI/ IEEE C95.1 - 1992 RF EXPOSURE LIMITS

HUMAN EXPOSURE	UNCONTROLLED ENVIRONMENT General Population (W/kg) or (mW/g)	CONTROLLED ENVIRONMENT Occupational (W/kg) or (mW/g)
SPATIAL PEAK SAR * (Brain)	1.60	8.00
SPATIAL AVERAGE SAR ** (Whole Body)	0.08	0.40
SPATIAL PEAK SAR *** (Hands / Feet / Ankle / Wrist)	4.00	20.00

Table 7.1 Safety Limits for Partial Body Exposure

NOTES:

* The Spatial Peak value of the SAR averaged over any 1 g of tissue (defined as a tissue volume in the shape of a cube) and over the appropriate averaging time.

** The Spatial Average value of the SAR averaged over the whole-body.

*** The Spatial Peak value of the SAR averaged over any 10 g of tissue (defined as a tissue volume in the shape of a cube) and over the appropriate averaging time.

Uncontrolled Environments are defined as locations where there is the exposure of individuals who have no knowledge or control of their exposure.

Controlled Environments are defined as locations where there is exposure that may be incurred by persons who are aware of the potential for exposure, (i.e.as a result of employment or occupation).

8. SYSTEM VERIFICATION

8.1 Tissue Verification

Freq. [MHz]	Date	Liquid	Liquid Temp.[°C]	Parameters	Target Value	Measured Value	Deviation [%]	Limit [%]
835	June 8, 2011	Head	21.3	ϵr	41.5	41.4	- 0.24	± 5
				σ	0.90	0.887	- 1.44	± 5
835	June 8, 2011	Body	21.3	ϵr	55.2	56.9	+ 3.08	± 5
				σ	0.97	0.981	+ 1.13	± 5
1 900	June 9, 2011	Head	21.2	ϵr	40.0	41.5	+ 3.75	± 5
				σ	1.40	1.4	0.00	± 5
1 900	June 9, 2011	Body	21.2	ϵr	53.3	52	- 2.44	± 5
				σ	1.52	1.56	+ 2.63	± 5
2 450	June 10, 2011	Head	21.4	ϵr	39.2	39.7	+ 1.28	± 5
				σ	1.80	1.84	+ 2.22	± 5
2 450	June 10, 2011	Body	21.4	ϵr	52.7	51.6	- 2.09	± 5
				σ	1.95	1.96	+ 0.51	± 5
750	May 6,2011	Head	21.2	ϵr	41.9	42.2	+ 0.72	± 5
				σ	0.89	0.866	- 2.70	± 5
750	May 9,2011	Body	21.3	ϵr	55.5	54.7	- 1.44	± 5
				σ	0.96	0.973	+ 1.35	± 5

8.2 System Validation

Prior to assessment, the system is verified to the $\pm 10\%$ of the specifications at 835 MHz / 750 MHz / 1 900 MHz/ 2 450 MHz by using the system validation kit. (Graphic Plots Attached) ^{*} Input Power: 100 m W

Freq. [MHz]	Date	Liquid	Liquid Temp. [°C]	SAR Average	Target Value (SPEAG) (mW/g)	*Measured Value (mW/g)	Deviation [%]	Limit [%]
835	June 8, 2011	Head	21.3	1 g	9.34	0.961	+2.89	± 10
835	June 8, 2011	Body	21.3	1 g	9.45	1.01	+6.88	± 10
1 900	June 9, 2011	Head	21.2	1 g	39.9	4.09	+ 2.51	± 10
1 900	June 9, 2011	Body	21.2	1 g	41.5	4.1	- 1.20	± 10
2 450	June 10, 2011	Head	21.4	1 g	54	5.48	+ 1.48	± 10
2 450	June 10, 2011	Body	21.4	1 g	54	5.41	+ 0.19	± 10
750	May 6,2011	Head	21.2	1 g	8.29	0.832	+ 0.36	± 10
750	May 9,2011	Body	21.3	1 g	8.8	0.893	+ 1.48	± 10

9. SAR Testing with IEEE 802.11 a/b/g Transmitters

Normal Network operating configurations are not suitable for measuring the SAR of 802.11 a/b/g transmitters. Unpredictable fluctuations in network traffic and antenna diversity conditions can introduce undesirable variations in SAR results. The SAR for these devices should be measured using chipset based test mode software to ensure the results are consistent and reliable.

9.1 General Device Setup

Chipset based test mode software is hardware dependent and generally varies among manufacturers. The device operating parameters established in test mode for SAR measurements must be identical to those programmed in production units, including output power levels, amplifier gain settings and other RF performance tuning parameters. The test frequencies should correspond to actual channel frequencies defined for domestic use. SAR for devices with switched diversity should be measured with only one antenna transmitting at a time during each SAR measurement, according to a fixed modulation and data rate. The same data pattern should be used for all measurements.

9.2 Frequency Channel Configurations

80.11 a/b/g and 4.9 GHz operating modes are tested independently according to the service requirements in each frequency band. 80.211 b/g modes are tested on channels 1, 6 and 11. 802.11a is tested for UNII operations on channels 36 and 48 in the 5.15-5.25 GHz band; channels 52 and 64 in the 5.25-5.35 GHz band; Channels 104, 116, 124 and 136 in the 5.470-5.725 GHz band; and channels 149 and 161 in the 5.8 GHz band. When 5.8 GHz § 15.247 is also available, channels 149, 157 and 165 should be tested instead of the UNII channels. 4.9 GHz is tested on channels 1, 10 and 5 or 6, whichever has the higher output power, for 5 MHz channels; channels 11, 15 and 19 for 10 MHz channels; and channels 21 and 25 for 20 MHz channels.

These are referred to as the “default test channels”. 802.11g mode was evaluated only if the output power was 0.25 dB higher than the 802.11b mode.

Mode	GHz	Channel	Turbo Channel	“Default Test Channels”		UNII	
				§15.247 802.11b	802.11g		
802.11 b/g	2.412	1		√	∇		
	2.437	6	6	√	∇		
	2.462	11		√	∇		
802.11a	5.18	36				√	
	5.20	40	42 (5.21 GHz)			*	
	5.22	44				*	
	5.24	48	50 (5.25 GHz)			√	
	5.26	52				√	
	5.28	56	58 (5.29 GHz)			*	
	5.30	60				*	
	5.32	64				√	
	UNII	5.500	100	Unknown			*
		5.520	104				√
		5.540	108				*
		5.560	112				*
		5.580	116				√
		5.600	120				*
		5.620	124				√
		5.640	128				*
	5.660	132			*		
	5.680	136			√		
	5.700	140				*	
	UNII or §15.247	5.745	149		√		√
5.765		153	152 (5.76 GHz)		*	*	
§15.247	5.785	157		√		*	
	5.805	161	160 (5.80 GHz)		*	√	
§15.247	5.825	165		√			

802.11 Test Channels per FCC Requirements

10. 3G MEASUREMENT PROCEDURES

10.1 Procedures Used To Establish Test Signal

The handset was placed into a simulated call using a base station simulator in a shielded chamber. Such test signals offer a consistent means for testing SAR and are recommended for evaluating SAR. SAR measurements were taken with a fully charged battery. In order to verify that the device was tested and maintained at full power, this was configured with the base station simulator. The SAR measurement software calculates a reference point at the start and end of the test to check for power drifts. If conducted power deviations of more than 5% occurred, the tests were repeated.

9.2 SAR Measurement Conditions for CDMA2000 1x

These procedures were followed according to FCC "SAR Measurement Procedures for 3G Devices", May 2006.

10.1.1 Output Power Verification

See 3GPP2 C.S0011/TIA-98-E as recommended by "SAR Measurement Procedures for 3G Devices", May 2006. MMaximum output power is verified on the High, Middle and Low channels according to procedures defined in section 4.4.5.2 of 3GPP2 C.S0011/TIA-98-E. SO55 tests were measured with power control bits in "All Up" condition.

1. If the mobile station supports Reverse TCH RC 1 and Forward TCH RC 1, set up a call using Fundamental Channel Test Mode 1 (RC=1/1) with 9 600 bps data rate only.
2. Under RC1, C.S0011 Table 4.4.5.2-1 (Table 9.1) parameters were applied.
3. If the MS supports the RC 3 Reverse FCH, RC3 Reverse SCH0 and demodulation of RC 3, 4, or 5, set up a call using Supplemental Channel Test Mode 3 (RC 3/3) with 9 600 bps Fundamental Channel and 9 600 bps SCH0 data rate Channel and 9 600 bps SCH0 data rate.
4. Under RC3, C.S0011 Table 4.4.5.2-2(Table 9.2) was applied.
5. FCHs were configured at full rate for mMaximum SAR with "All Up" power control bits.

Parameters for Max. Power for RC1

Parameter	Units	Value
\bar{I}_{or}	dBm/1.23 MHz	-104
$\frac{Pilot E_c}{I_{or}}$	dB	-7
$\frac{Traffic E_c}{I_{or}}$	dB	-7.4

Table. 9.1

Parameters for Max. Power for RC3

Parameter	Units	Value
\bar{I}_{or}	dBm/1.23 MHz	-86
$\frac{Pilot E_c}{I_{or}}$	dB	-7
$\frac{Traffic E_c}{I_{or}}$	dB	-7.4

Table. 9.2

10.1.2 Head SAR Measurement

SAR for head exposure configurations is measured in RC3 with the DUT configured to transmit at full rate using Loopback Service Option SO55. SAR for RC1 is not required when the mMaximum average output of each channel is less than ¼ dB higher than that measured in RC3. Otherwise, SAR is measured on the mMaximum output channel in RC1 using the exposure configuration that results in the highest SAR for that channel in RC3.

10.1.3 Body SAR Measurement

SAR for body exposure configurations is measured in RC3 with the DUT configured to transmit at full rate on FCH with all other code channels disabled using TDSO / SO32. SAR for multiple code channels (FCH + SCHn) is not required when the mMaximum average output of each RF channel is less than ¼ dB higher than that measured with FCH only. Otherwise, SAR is measured on the mMaximum output channel (FCH + SCHn) with FCH at full rate and SCH0 enabled at 9 600 bps using the exposure configuration that results in the highest SAR for that channel with FCH only. When multiple code channels are enabled, the DUT output may shift by more than 0.5 dB and lead to higher SAR drifts and SCH dropouts.

Body SAR in RC1 is not required when the mMaximum average output of each channel is less than ¼ dB higher than that measured in RC3. Otherwise, SAR is measured on the mMaximum output channel in RC1; with Loopback Service Option SO55, at full rate, using the body exposure configuration that results in the highest SAR for that channel in RC3.

10.1.4 Handsets with EV-DO

For handsets with Ev-Do capabilities, when the mMaximum average output of each channel in Rev. 0 is less than ¼ dB higher than that measured in RC3 (1x RTT), body SAR for Ev-Do is not required. Otherwise, SAR for Rev. 0 is measured on the mMaximum output channel at 153.6 kbps using the body exposure configuration that results in the highest SAR for that channel in RC3. SAR for Rev. A is not required when the mMaximum average output of each channel is less than that measured in Rev. 0 or less than ¼ dB higher than that measured in RC3. Otherwise, SAR is measured on the mMaximum output channel for Rev. A using a Reverse Data Channel payload size of 4 096 bits and a Termination Target of 16 slots defined for Subtype 2 Physical Layer configurations. A Forward Traffic Channel data rate corresponding to the 2-slot version of 307.2 kbps with the ACK Channel transmitting in all slots should be configured in the downlink for both Rev. 0 and Rev. A.

Average Output Power Measurement without for FCC ID: JYCAPACHE

Band	Channel	SO2	SO2	SO55	SO55	TDSO SO32	1xEvDO Rev.0	1xEvDO Rev.0	1xEvDO Rev.A	1xEvDO Rev.A
		RC1/1 (dBm)	RC3/3 (dBm)	RC1/1 (dBm)	RC3/3 (dBm)	RC3/3 (dBm)	(FTAP)	(RTAP)	(FETAP)	(RETAP)
CDMA	1013	24.17	24.12	24.13	24.14	24.21	24.34	24.12	24.34	24.24
	384	24.18	24.19	24.20	24.23	24.19	24.46	24.32	24.38	24.32
	777	24.22	24.38	24.36	24.33	24.32	24.45	24.44	24.45	24.46
PCS	25	24.25	24.17	24.22	24.26	24.24	24.27	24.28	24.10	24.15
	600	24.37	24.31	24.30	24.42	24.37	24.11	24.32	24.24	24.25
	1175	24.42	24.41	24.34	24.41	24.35	24.48	24.31	24.40	24.43

Table 10.1 CDMA Conducted output powers

UL Freq.(MHz)	UL Channel	Modulation	Bandwidth	RB Size	Resource Block Offset	Maximum Average Power [dBm]	MPR	Power reduction (dB)
782	23230	QPSK	10MHz	1	0	23.32	0	-0.32
782	23230	16QAM	10MHz	1	0	22.38	1	0.62
782	23230	QPSK	10MHz	1	49	23.23	0	-0.23
782	23230	16QAM	10MHz	1	49	22.25	1	0.75
782	23230	QPSK	10MHz	25	13	22.31	1	0.69
782	23230	16QAM	10MHz	25	13	21.18	2	1.82
782	23230	QPSK	10MHz	50	0	22.23	1	0.77
782	23230	16QAM	10MHz	50	0	21.14	2	1.86

Table 10.2 LTE Conducted output powers

Note;

The JYCAPACHE developed base on MPR. The MPR is mandatory.

The device will not operate with any other MPR setting than that stated in the table as indicated.

SAR Testing was performed using a CMW500. UE transmits with Maximum output power during SAR testing.

Band	Channel	Mbps (dBm)			
		1	2	5.5	11
IEEE 802.11b	1	16.08	15.60	14.92	13.74
	6	16.58	16.05	15.17	14.20
	11	16.01	15.64	14.65	13.78

Table 10 3. Average IEEE 802.11b Conducted output power

Band	Channel	Mbps (dBm)							
		6	9	12	18	24	36	48	54
IEEE 802.11g	1	11.86	11.34	10.73	1.012	9.25	7.99	7.18	6.84
	6	12.51	11.61	11.21	10.12	9.45	8.44	7.66	7.32
	11	12.55	12.05	11.22	10.24	9.56	8.31	7.72	7.42

Table 10 4. Average IEEE 802.11g Conducted output power

Band	Channel	Mbps (dBm)							
		6.5	13	20	26	39	52	58	65
IEEE 802.11n (HT-20)	1	9.80	8.46	7.90	6.99	6.00	5.08	4.81	4.52
	6	10.31	9.05	7.91	7.24	6.23	5.35	5.05	4.78
	11	10.45	9.16	8.28	7.37	6.62	5.59	5.32	4.90

Table 10 5. Average IEEE 802.11n Conducted output power

11. SVLTE/SVDO RF Conducted Power

The EUT is dual transmitter Simultaneous Voice and Data device that contains two independent WWAN transmitters with the capabilities listed in Table 11.1. The primary transmitter supports a CDMA2000 1x call(e.g. voice, SMS) and the secondary transmitter supports a CDMA2000 EVDO or LTE data call. A simultaneous CDMA 1x voice and CDMA EVDO data connection is referred to as “SVDO” while a simultaneous CDMA 1x voice and LTE data connection is referred to as “SVLTE”. The transmitters are independent in respect to the RF chains as each transmitter has dedicated RF circuitry(PA, RF filtering) and a unique transmit antenna. The device also contains an additional antenna associated with receiver diversity. The LTE UL MIMO configuration is 1x2(1 UL antenna and 2 DL RX antennas)

Mode	Band	Frequency	Channel Bandwidth(MHz)
Voice	CDMA2000 1x	Band Class 0 : 824-849 MHz Band Class 1 : 1850-1910 MHz	1.23MHz 1.25MHz
Data	CDMA2000 1x EvDO Rev A	Band Class 0 : 824-849 MHz Band Class 1 : 1850-1910 MHz	1.23MHz 1.25MHz
Data	LTE	Band 13(Upper 700MHz) 777-787 MHz	Max of 10MHz
Data	802.11b/g/n	2.45GHz	20MHz

Table 11.1 EUT Technology Support

Antenna	Antenna Use	Technologies	TX Bands
1	Voice1x Tx + DO Rx + LTE diversity	1x Tx	850/1900
2	DO<E Data Tx + 1x Rx	EvDo Tx + LTE Tx	850/1900/700
3	WLAN/BT	802.11 + Bluetooth	2400MHz

Table 11.2 Definition of Antennas

Mode	Voice Average Power 1x(dBm)	Maximum EVDO Average Power (dBm)
SVDO	P<15	24
	P≥ 15	18
Mode	Voice Average Power 1x (dBm)	Maximum LTE Average Power (dBm)
SVLTE	P<18	23
	P≥ 18	19

Table 11.3 Power reduction Settings

A-MPR was disabled by setting NS=01 on the R&S CMW500.

The WLAN and Bluetooth cannot transmit simultaneously, so there is no co-location test requirement for WLAN and Bluetooth.

11.1 LTE/SVLTE/SVDO Conducted Power measurement Test Setup

11.1.1 Conducted Output Power Measurement for LTE

11.1.1.1 Description of the Conducted Output Power Measurement

A base station simulator was used to establish communication with the EUT. Its parameters were set to transmit the mMaximum power on the EUT. The measured power in the radio frequency on the transmitter output terminals shall be reported.

11.1.1.2 Test Procedures

1. The transmitter output port was connected to base station.
2. Set EUT at mMaximum power through base station.
3. Select RB for each case and different modulation.

11.1.1.3 Test Setup

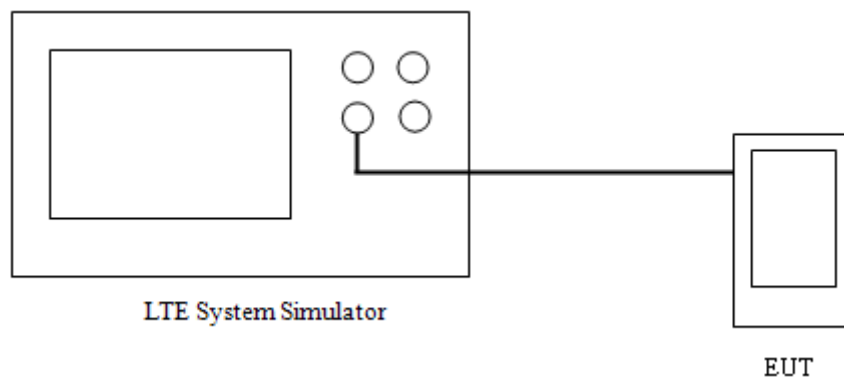

11.1.2 Conducted Output Power Measurement for SVLTE

11.1.2.1 Description of the Conducted Output Power Measurement

Two base station simulator were used to establish communication with the EUT. Its parameters were set to transmit the mMaximum power on the EUT. The measured power in the radio frequency on the transmitter output terminals shall be reported.

11.1.2.2 Test Procedures

1. Primary transmitter output port was connected to base station.
2. Secondary transmitter output port was connected to base station.
3. Set EUT at mMaximum power through base station.
4. Select RB for each case and different modulation.
5. Select lowest, middle, and highest channels for each band.

11.1.2.3 Test Setup

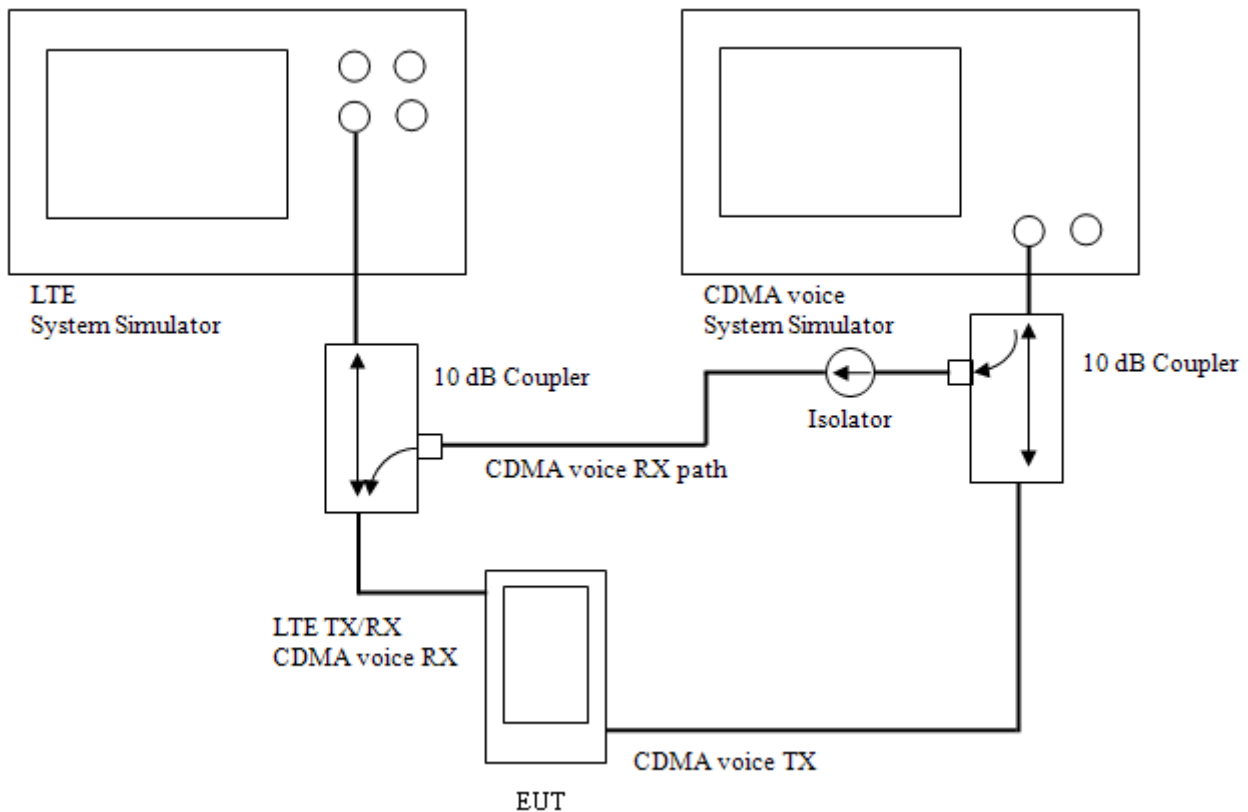

11.1.3 Conducted Output Power Measurement for SVDO

11.1.3.1 Description of the Conducted Output Power Measurement

Two base station simulator were used to establish communication with the EUT. Its parameters were set to transmit the mMaximum power on the EUT. The measured power in the radio frequency on the transmitter output terminals shall be reported.

11.1.3.2 Test Procedures

1. Primary transmitter output port was connected to base station of CDMA voice.
2. Secondary transmitter output port was connected to base station of EvDO.
3. Set EUT at mMaximum power through base station.
4. Select lowest, middle, and highest channels for each band.

11.1.3.3 Test Setup

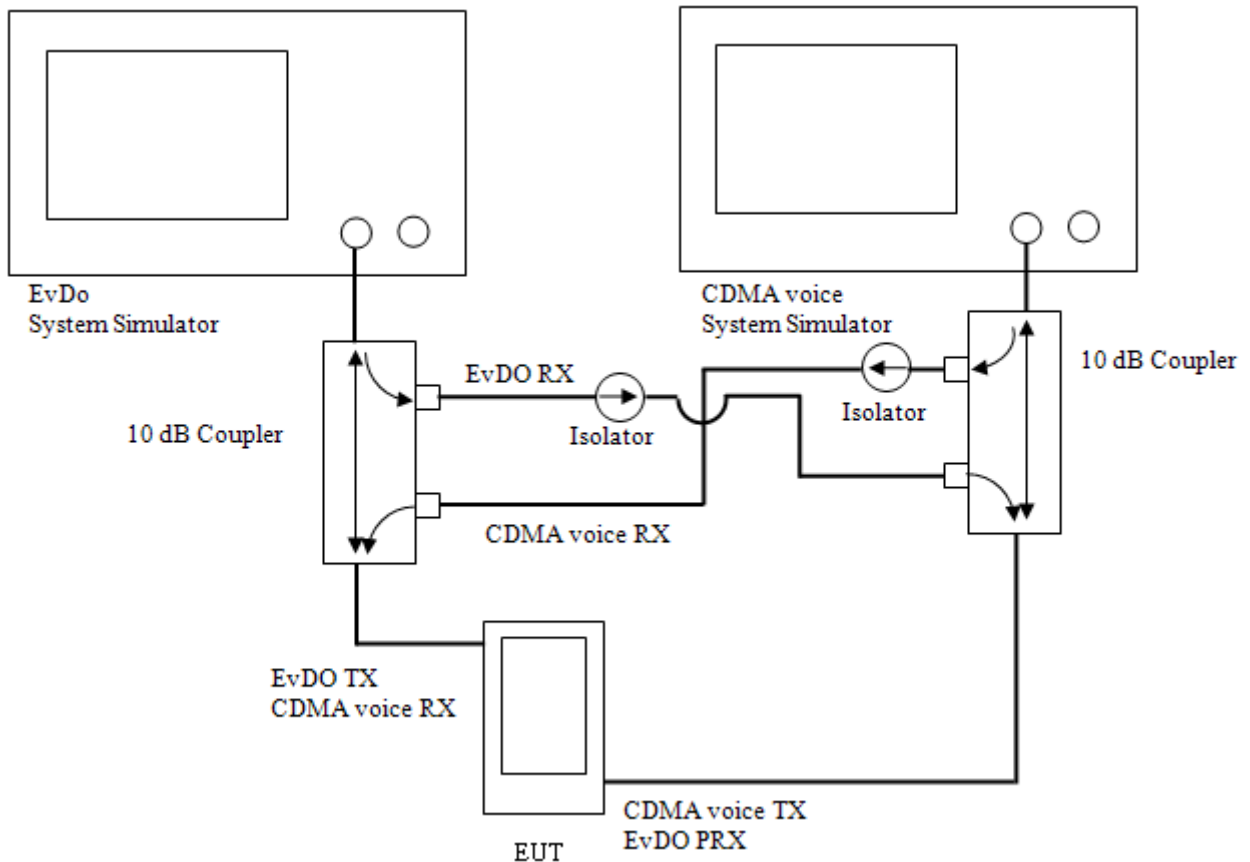

Table 11.4 SVLTE Power reduction Table

Voice Band	Voice Channel	Voice Power (dBm)	Expected Measured Data Transmit Power							
			LTE 700MHz (RB allocation / RB#)							
			RB=25 RB#13 QPSK	RB=1 RB#49 QPSK	RB=1 RB#0 QPSK	RB=50 RB#0 QPSK	RB=25 RB#13 16QAM	RB=1 RB#49 16QAM	RB=1 RB#0 16QAM	RB=50 RB#0 16QAM
850MHz	Low	24	19.4	19.2	19.2	19.3	19.2	19.2	19.2	19.1
	Low	23	19.4	19.2	19.2	19.3	19.2	19.2	19.2	19.1
	Low	22	19.4	19.2	19.2	19.3	19.2	19.2	19.2	19.1
	Low	21	19.4	19.2	19.2	19.3	19.2	19.2	19.2	19.1
	Low	20	19.4	19.2	19.2	19.3	19.2	19.2	19.2	19.1
	Low	19	19.4	19.2	19.2	19.3	19.2	19.2	19.2	19.1
	Low	18	19.4	19.2	19.2	19.3	19.2	19.2	19.2	19.1
	Low	17	22.3	23.2	23.3	22.2	21.2	22.3	22.4	21.1
	Low	16	22.3	23.2	23.3	22.2	21.2	22.3	22.4	21.1
	Low	15	22.3	23.2	23.3	22.2	21.2	22.3	22.4	21.1
	Low	14	22.3	23.2	23.3	22.2	21.2	22.3	22.4	21.1
	Low	13	22.3	23.2	23.3	22.2	21.2	22.3	22.4	21.1
	Low	12	22.3	23.2	23.3	22.2	21.2	22.3	22.4	21.1
Low	11	22.3	23.2	23.3	22.2	21.2	22.3	22.4	21.1	

Voice Band	Voice Channel	Voice Power (dBm)	Expected Measured Data Transmit Power							
			LTE 700MHz (RB allocation / RB#)							
			RB=25 RB#13 QPSK	RB=1 RB#49 QPSK	RB=1 RB#0 QPSK	RB=50 RB#0 QPSK	RB=25 RB#13 16QAM	RB=1 RB#49 16QAM	RB=1 RB#0 16QAM	RB=50 RB#0 16QAM
850MHz	Mid	24	19.4	19.2	19.2	19.3	19.2	19.2	19.2	19.1
	Mid	23	19.4	19.2	19.2	19.3	19.2	19.2	19.2	19.1
	Mid	22	19.4	19.2	19.2	19.3	19.2	19.2	19.2	19.1
	Mid	21	19.4	19.2	19.2	19.3	19.2	19.2	19.2	19.1
	Mid	20	19.4	19.2	19.2	19.3	19.2	19.2	19.2	19.1
	Mid	19	19.4	19.2	19.2	19.3	19.2	19.2	19.2	19.1
	Mid	18	19.4	19.2	19.2	19.3	19.2	19.2	19.2	19.1
	Mid	17	22.3	23.2	23.3	22.2	21.2	22.3	22.4	21.1
	Mid	16	22.3	23.2	23.3	22.2	21.2	22.3	22.4	21.1
	Mid	15	22.3	23.2	23.3	22.2	21.2	22.3	22.4	21.1
	Mid	14	22.3	23.2	23.3	22.2	21.2	22.3	22.4	21.1
	Mid	13	22.3	23.2	23.3	22.2	21.2	22.3	22.4	21.1
	Mid	12	22.3	23.2	23.3	22.2	21.2	22.3	22.4	21.1
Mid	11	22.3	23.2	23.3	22.2	21.2	22.3	22.4	21.1	

Voice Band	Voice Channel	Voice Power (dBm)	Expected Measured Data Transmit Power							
			LTE 700MHz (RB allocation / RB#)							
			RB=25 RB#13 QPSK	RB=1 RB#49 QPSK	RB=1 RB#0 QPSK	RB=50 RB#0 QPSK	RB=25 RB#13 16QAM	RB=1 RB#49 16QAM	RB=1 RB#0 16QAM	RB=50 RB#0 16QAM
850MHz	High	24	19.4	19.2	19.2	19.3	19.2	19.2	19.2	19.1
	High	23	19.4	19.2	19.2	19.3	19.2	19.2	19.2	19.1
	High	22	19.4	19.2	19.2	19.3	19.2	19.2	19.2	19.1
	High	21	19.4	19.2	19.2	19.3	19.2	19.2	19.2	19.1
	High	20	19.4	19.2	19.2	19.3	19.2	19.2	19.2	19.1
	High	19	19.4	19.2	19.2	19.3	19.2	19.2	19.2	19.1
	High	18	19.4	19.2	19.2	19.3	19.2	19.2	19.2	19.1
	High	17	22.3	23.2	23.3	22.2	21.2	22.3	22.4	21.1
	High	16	22.3	23.2	23.3	22.2	21.2	22.3	22.4	21.1
	High	15	22.3	23.2	23.3	22.2	21.2	22.3	22.4	21.1
	High	14	22.3	23.2	23.3	22.2	21.2	22.3	22.4	21.1
	High	13	22.3	23.2	23.3	22.2	21.2	22.3	22.4	21.1
	High	12	22.3	23.2	23.3	22.2	21.2	22.3	22.4	21.1
High	11	22.3	23.2	23.3	22.2	21.2	22.3	22.4	21.1	

Voice Band	Voice Channel	Voice Power (dBm)	Expected Measured Data Transmit Power							
			LTE 700MHz (RB allocation / RB#)							
			RB=25 RB#13 QPSK	RB=1 RB#49 QPSK	RB=1 RB#0 QPSK	RB=50 RB#0 QPSK	RB=25 RB#13 16QAM	RB=1 RB#49 16QAM	RB=1 RB#0 16QAM	RB=50 RB#0 16QAM
1900 MHz	Low	24	19.4	19.2	19.2	19.3	19.2	19.2	19.2	19.1
	Low	23	19.4	19.2	19.2	19.3	19.2	19.2	19.2	19.1
	Low	22	19.4	19.2	19.2	19.3	19.2	19.2	19.2	19.1
	Low	21	19.4	19.2	19.2	19.3	19.2	19.2	19.2	19.1
	Low	20	19.4	19.2	19.2	19.3	19.2	19.2	19.2	19.1
	Low	19	19.4	19.2	19.2	19.3	19.2	19.2	19.2	19.1
	Low	18	19.4	19.2	19.2	19.3	19.2	19.2	19.2	19.1
	Low	17	22.3	23.2	23.3	22.2	21.2	22.3	22.4	21.1
	Low	16	22.3	23.2	23.3	22.2	21.2	22.3	22.4	21.1
	Low	15	22.3	23.2	23.3	22.2	21.2	22.3	22.4	21.1
	Low	14	22.3	23.2	23.3	22.2	21.2	22.3	22.4	21.1
	Low	13	22.3	23.2	23.3	22.2	21.2	22.3	22.4	21.1
	Low	12	22.3	23.2	23.3	22.2	21.2	22.3	22.4	21.1
Low	11	22.3	23.2	23.3	22.2	21.2	22.3	22.4	21.1	

Voice Band	Voice Channel	Voice Power (dBm)	Expected Measured Data Transmit Power							
			LTE 700MHz (RB allocation / RB#)							
			RB=25 RB#13 QPSK	RB=1 RB#49 QPSK	RB=1 RB#0 QPSK	RB=50 RB#0 QPSK	RB=25 RB#13 16QAM	RB=1 RB#49 16QAM	RB=1 RB#0 16QAM	RB=50 RB#0 16QAM
1900 MHz	Mid	24	19.4	19.2	19.2	19.3	19.2	19.2	19.2	19.1
	Mid	23	19.4	19.2	19.2	19.3	19.2	19.2	19.2	19.1
	Mid	22	19.4	19.2	19.2	19.3	19.2	19.2	19.2	19.1
	Mid	21	19.4	19.2	19.2	19.3	19.2	19.2	19.2	19.1
	Mid	20	19.4	19.2	19.2	19.3	19.2	19.2	19.2	19.1
	Mid	19	19.4	19.2	19.2	19.3	19.2	19.2	19.2	19.1
	Mid	18	19.4	19.2	19.2	19.3	19.2	19.2	19.2	19.1
	Mid	17	22.3	23.2	23.3	22.2	21.2	22.3	22.4	21.1
	Mid	16	22.3	23.2	23.3	22.2	21.2	22.3	22.4	21.1
	Mid	15	22.3	23.2	23.3	22.2	21.2	22.3	22.4	21.1
	Mid	14	22.3	23.2	23.3	22.2	21.2	22.3	22.4	21.1
	Mid	13	22.3	23.2	23.3	22.2	21.2	22.3	22.4	21.1
	Mid	12	22.3	23.2	23.3	22.2	21.2	22.3	22.4	21.1
	Mid	11	22.3	23.2	23.3	22.2	21.2	22.3	22.4	21.1

Voice Band	Voice Channel	Voice Power (dBm)	Expected Measured Data Transmit Power							
			LTE 700MHz (RB allocation / RB#)							
			RB=25 RB#13 QPSK	RB=1 RB#49 QPSK	RB=1 RB#0 QPSK	RB=50 RB#0 QPSK	RB=25 RB#13 16QAM	RB=1 RB#49 16QAM	RB=1 RB#0 16QAM	RB=50 RB#0 16QAM
1900 MHz	High	24	19.4	19.2	19.2	19.3	19.2	19.2	19.2	19.1
	High	23	19.4	19.2	19.2	19.3	19.2	19.2	19.2	19.1
	High	22	19.4	19.2	19.2	19.3	19.2	19.2	19.2	19.1
	High	21	19.4	19.2	19.2	19.3	19.2	19.2	19.2	19.1
	High	20	19.4	19.2	19.2	19.3	19.2	19.2	19.2	19.1
	High	19	19.4	19.2	19.2	19.3	19.2	19.2	19.2	19.1
	High	18	19.4	19.2	19.2	19.3	19.2	19.2	19.2	19.1
	High	17	22.3	23.2	23.3	22.2	21.2	22.3	22.4	21.1
	High	16	22.3	23.2	23.3	22.2	21.2	22.3	22.4	21.1
	High	15	22.3	23.2	23.3	22.2	21.2	22.3	22.4	21.1
	High	14	22.3	23.2	23.3	22.2	21.2	22.3	22.4	21.1
	High	13	22.3	23.2	23.3	22.2	21.2	22.3	22.4	21.1
	High	12	22.3	23.2	23.3	22.2	21.2	22.3	22.4	21.1
	High	11	22.3	23.2	23.3	22.2	21.2	22.3	22.4	21.1

Table 11.5 SVDO Power reduction Table

Voice Band	Voice Channel	Voice Power (dBm)	Expected Measured Data Transmit Power					
			DO 850MHz			DO 1900MHz		
			Low	Mid	High	Low	Mid	High
850MHz	Low	24	18.1	18.1	18.3	18.2	18.4	18.4
	Low	23	18.1	18.1	18.3	18.2	18.4	18.4
	Low	22	18.1	18.1	18.3	18.2	18.4	18.4
	Low	21	18.1	18.1	18.3	18.2	18.4	18.4
	Low	20	18.1	18.1	18.3	18.2	18.4	18.4
	Low	19	18.1	18.1	18.3	18.2	18.4	18.4
	Low	18	18.1	18.1	18.3	18.2	18.4	18.4
	Low	17	18.1	18.1	18.3	18.2	18.4	18.4
	Low	16	18.1	18.1	18.3	18.2	18.4	18.4
	Low	15	18.1	18.1	18.3	18.2	18.4	18.4
	Low	14	24.2	24.3	24.4	24.1	24.2	24.4
	Low	13	24.2	24.3	24.4	24.1	24.2	24.4
	Low	12	24.2	24.3	24.4	24.1	24.2	24.4
	Low	11	24.2	24.3	24.4	24.1	24.2	24.4

Voice Band	Voice Channel	Voice Power (dBm)	Expected Measured Data Transmit Power					
			DO 850MHz			DO 1900MHz		
			Low	Mid	High	Low	Mid	High
850MHz	Mid	24	18.1	18.1	18.3	18.2	18.4	18.4
	Mid	23	18.1	18.1	18.3	18.2	18.4	18.4
	Mid	22	18.1	18.1	18.3	18.2	18.4	18.4
	Mid	21	18.1	18.1	18.3	18.2	18.4	18.4
	Mid	20	18.1	18.1	18.3	18.2	18.4	18.4
	Mid	19	18.1	18.1	18.3	18.2	18.4	18.4
	Mid	18	18.1	18.1	18.3	18.2	18.4	18.4
	Mid	17	18.1	18.1	18.3	18.2	18.4	18.4
	Mid	16	18.1	18.1	18.3	18.2	18.4	18.4
	Mid	15	18.1	18.1	18.3	18.2	18.4	18.4
	Mid	14	24.2	24.3	24.4	24.1	24.2	24.4
	Mid	13	24.2	24.3	24.4	24.1	24.2	24.4
	Mid	12	24.2	24.3	24.4	24.1	24.2	24.4
	Mid	11	24.2	24.3	24.4	24.1	24.2	24.4
Voice Band	Voice Channel	Voice Power (dBm)	Expected Measured Data Transmit Power					
			DO 850MHz			DO 1900MHz		
			Low	Mid	High	Low	Mid	High
850MHz	High	24	18.1	18.1	18.3	18.2	18.4	18.4
	High	23	18.1	18.1	18.3	18.2	18.4	18.4
	High	22	18.1	18.1	18.3	18.2	18.4	18.4
	High	21	18.1	18.1	18.3	18.2	18.4	18.4
	High	20	18.1	18.1	18.3	18.2	18.4	18.4
	High	19	18.1	18.1	18.3	18.2	18.4	18.4
	High	18	18.1	18.1	18.3	18.2	18.4	18.4
	High	17	18.1	18.1	18.3	18.2	18.4	18.4
	High	16	18.1	18.1	18.3	18.2	18.4	18.4
	High	15	18.1	18.1	18.3	18.2	18.4	18.4
	High	14	24.2	24.3	24.4	24.1	24.2	24.4
	High	13	24.2	24.3	24.4	24.1	24.2	24.4
	High	12	24.2	24.3	24.4	24.1	24.2	24.4
	High	11	24.2	24.3	24.4	24.1	24.2	24.4

Voice Band	Voice Channel	Voice Power (dBm)	Expected Measured Data Transmit Power					
			DO 850MHz			DO 1900MHz		
			Low	Mid	High	Low	Mid	High
1900MHz	Low	24	18.1	18.1	18.3	18.2	18.4	18.4
	Low	23	18.1	18.1	18.3	18.2	18.4	18.4
	Low	22	18.1	18.1	18.3	18.2	18.4	18.4
	Low	21	18.1	18.1	18.3	18.2	18.4	18.4
	Low	20	18.1	18.1	18.3	18.2	18.4	18.4
	Low	19	18.1	18.1	18.3	18.2	18.4	18.4
	Low	18	18.1	18.1	18.3	18.2	18.4	18.4
	Low	17	18.1	18.1	18.3	18.2	18.4	18.4
	Low	16	18.1	18.1	18.3	18.2	18.4	18.4
	Low	15	18.1	18.1	18.3	18.2	18.4	18.4
	Low	14	24.2	24.3	24.4	24.1	24.2	24.4
	Low	13	24.2	24.3	24.4	24.1	24.2	24.4
	Low	12	24.2	24.3	24.4	24.1	24.2	24.4
Low	11	24.2	24.3	24.4	24.1	24.2	24.4	

Voice Band	Voice Channel	Voice Power (dBm)	Expected Measured Data Transmit Power					
			DO 850MHz			DO 1900MHz		
			Low	Mid	High	Low	Mid	High
1900MHz	Mid	24	18.1	18.1	18.3	18.2	18.4	18.4
	Mid	23	18.1	18.1	18.3	18.2	18.4	18.4
	Mid	22	18.1	18.1	18.3	18.2	18.4	18.4
	Mid	21	18.1	18.1	18.3	18.2	18.4	18.4
	Mid	20	18.1	18.1	18.3	18.2	18.4	18.4
	Mid	19	18.1	18.1	18.3	18.2	18.4	18.4
	Mid	18	18.1	18.1	18.3	18.2	18.4	18.4
	Mid	17	18.1	18.1	18.3	18.2	18.4	18.4
	Mid	16	18.1	18.1	18.3	18.2	18.4	18.4
	Mid	15	18.1	18.1	18.3	18.2	18.4	18.4
	Mid	14	24.2	24.3	24.4	24.1	24.2	24.4
	Mid	13	24.2	24.3	24.4	24.1	24.2	24.4
	Mid	12	24.2	24.3	24.4	24.1	24.2	24.4
Mid	11	24.2	24.3	24.4	24.1	24.2	24.4	

Voice Band	Voice Channel	Voice Power (dBm)	Expected Measured Data Transmit Power					
			DO 850MHz			DO 1900MHz		
			Low	Mid	High	Low	Mid	High
1900MHz	High	24	18.1	18.1	18.3	18.2	18.4	18.4
	High	23	18.1	18.1	18.3	18.2	18.4	18.4
	High	22	18.1	18.1	18.3	18.2	18.4	18.4
	High	21	18.1	18.1	18.3	18.2	18.4	18.4
	High	20	18.1	18.1	18.3	18.2	18.4	18.4
	High	19	18.1	18.1	18.3	18.2	18.4	18.4
	High	18	18.1	18.1	18.3	18.2	18.4	18.4
	High	17	18.1	18.1	18.3	18.2	18.4	18.4
	High	16	18.1	18.1	18.3	18.2	18.4	18.4
	High	15	18.1	18.1	18.3	18.2	18.4	18.4
	High	14	24.2	24.3	24.4	24.1	24.2	24.4
	High	13	24.2	24.3	24.4	24.1	24.2	24.4
	High	12	24.2	24.3	24.4	24.1	24.2	24.4
High	11	24.2	24.3	24.4	24.1	24.2	24.4	

12. LTE PLOTS

The following plots show LTE Maximum transmit power results at voice transmit power levels more than 18dBm and following plots represent for each modulation.

RB1, Offset0, QPSK Plot

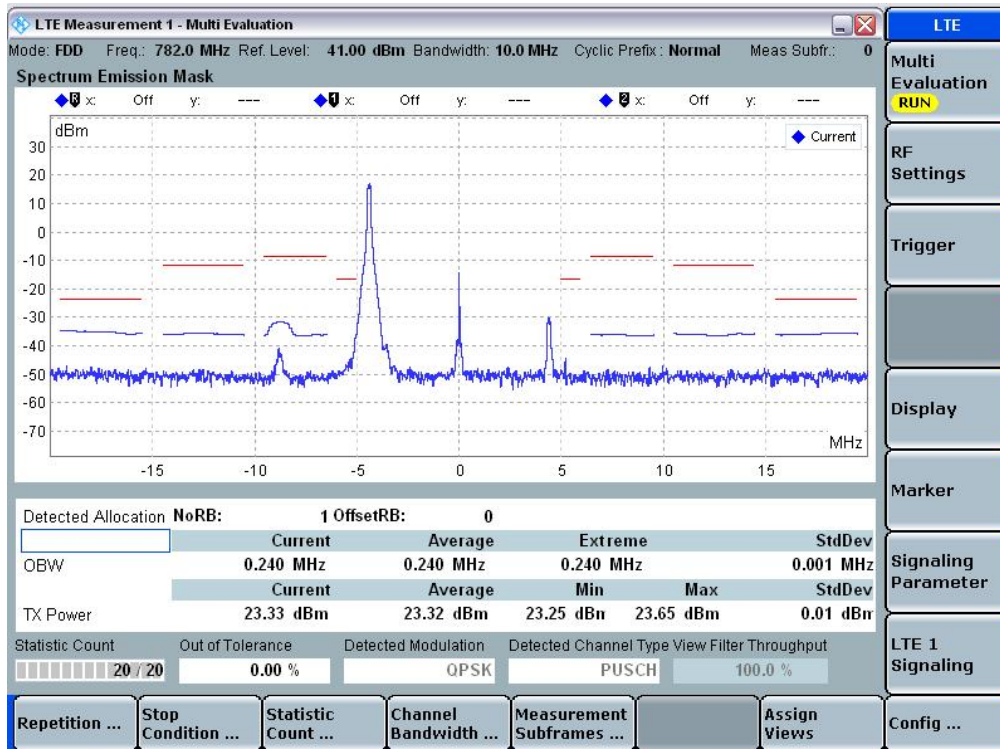

RB1, Offset0, 16QAM Plot

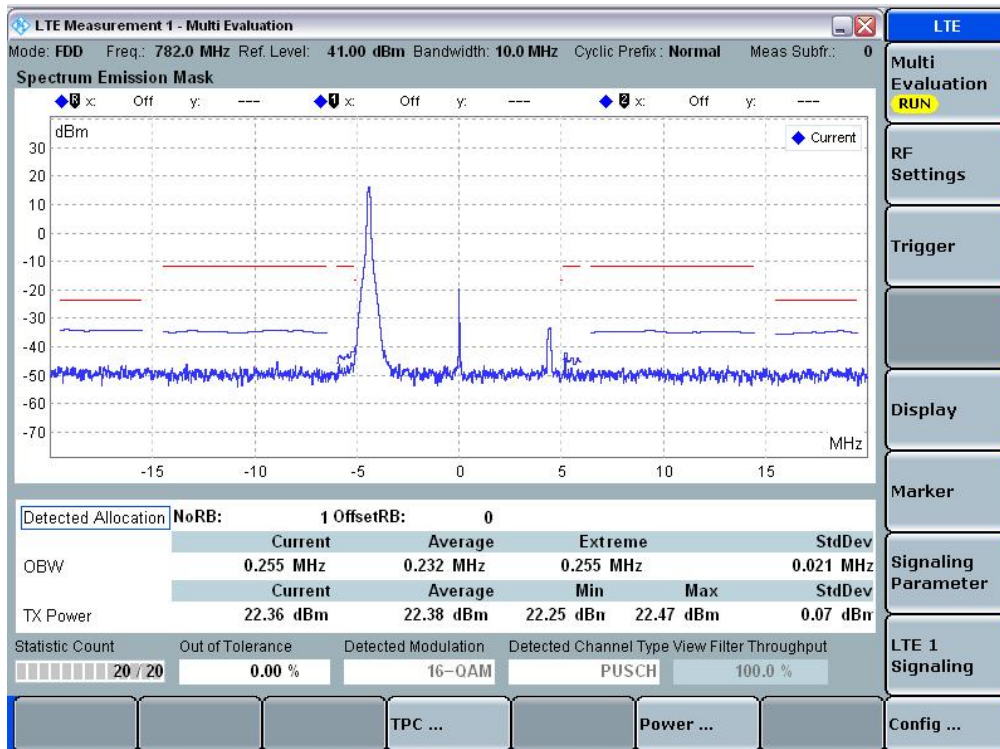

RB1, Offset49, QPSK Plot

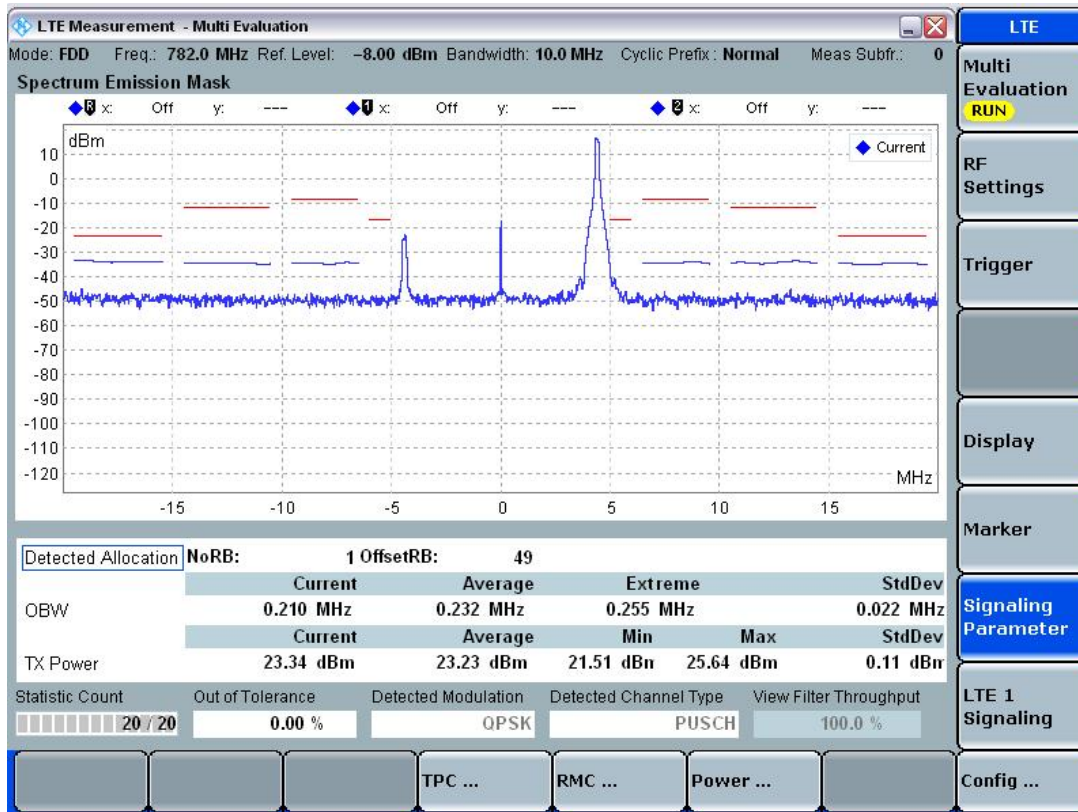

RB1, Offset49, 16QAM Plot

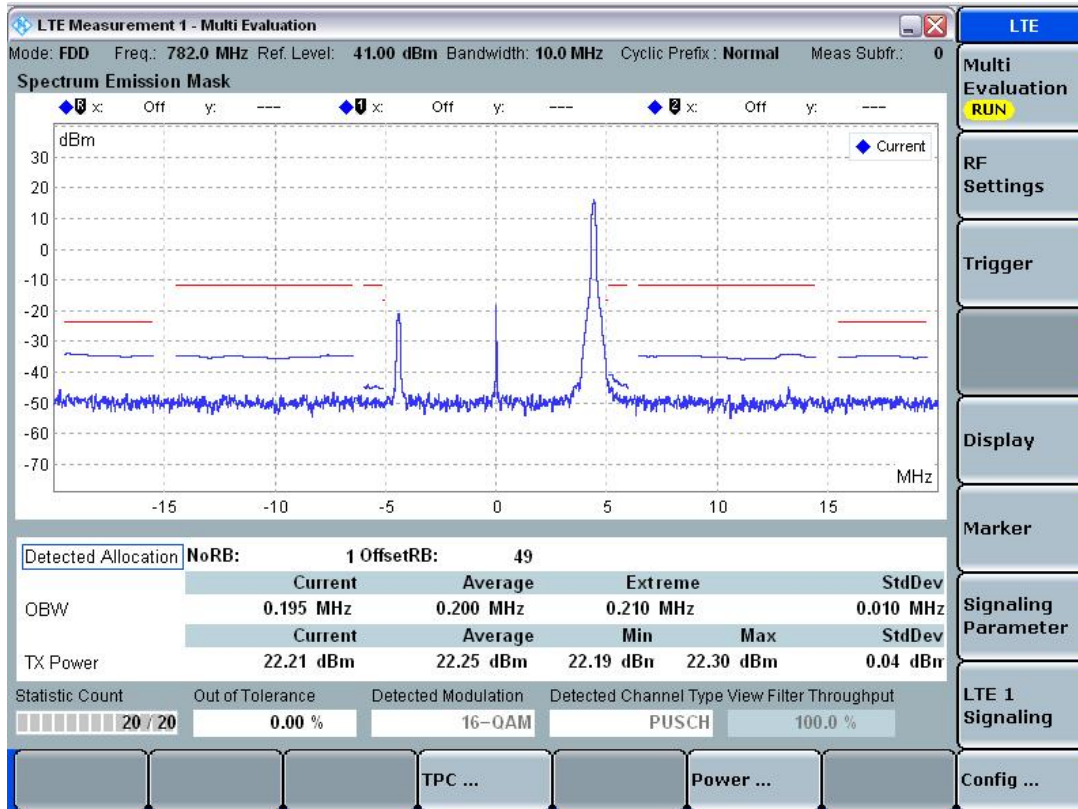

RB25, Offset13, QPSK Plot

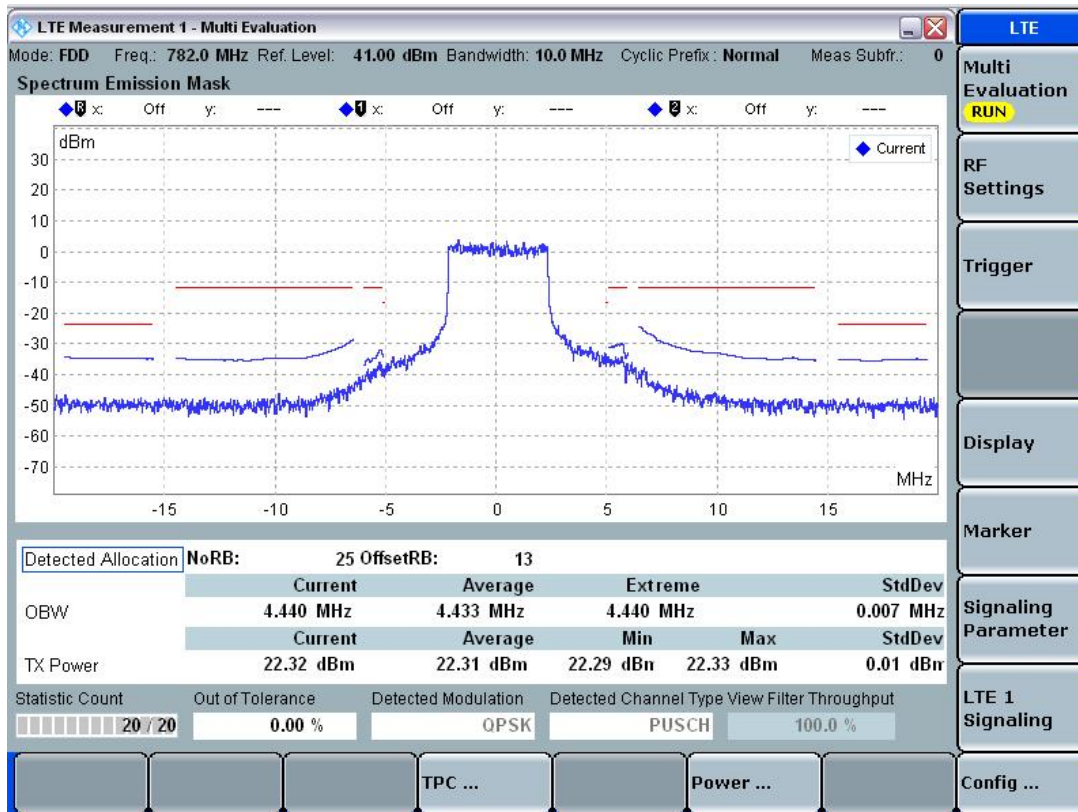

RB25, Offset13, 16QAM Plot

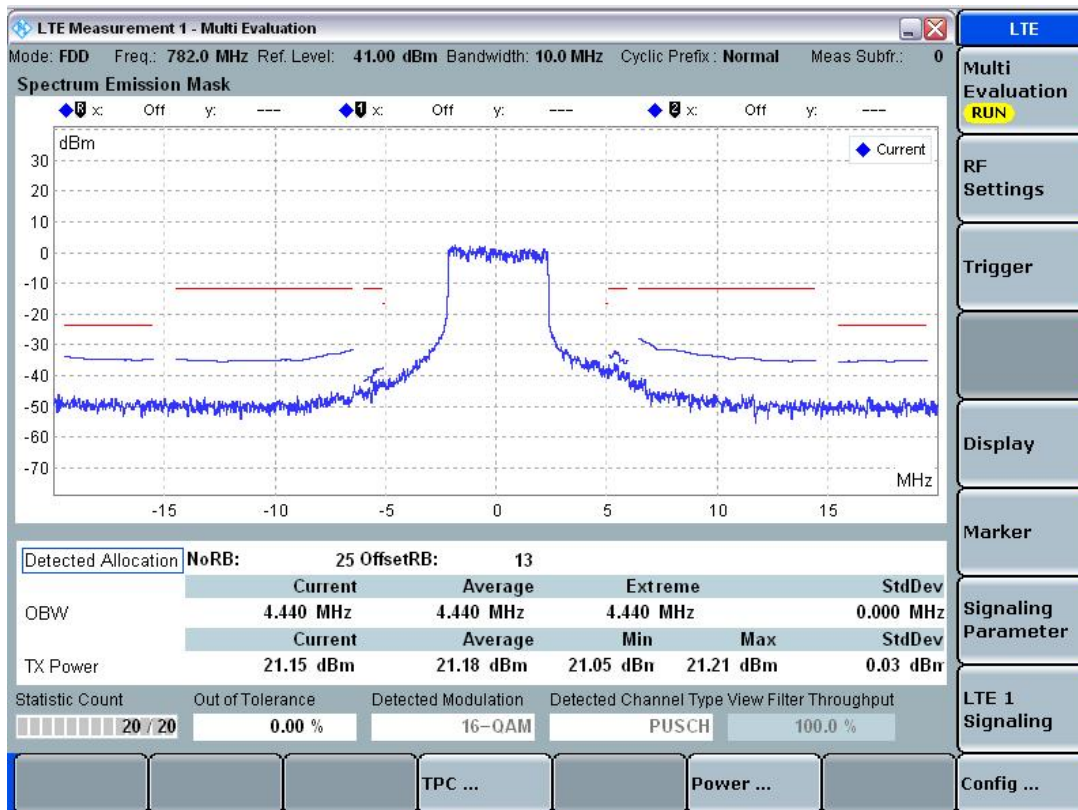

RB50, Offset0, QPSK Plot

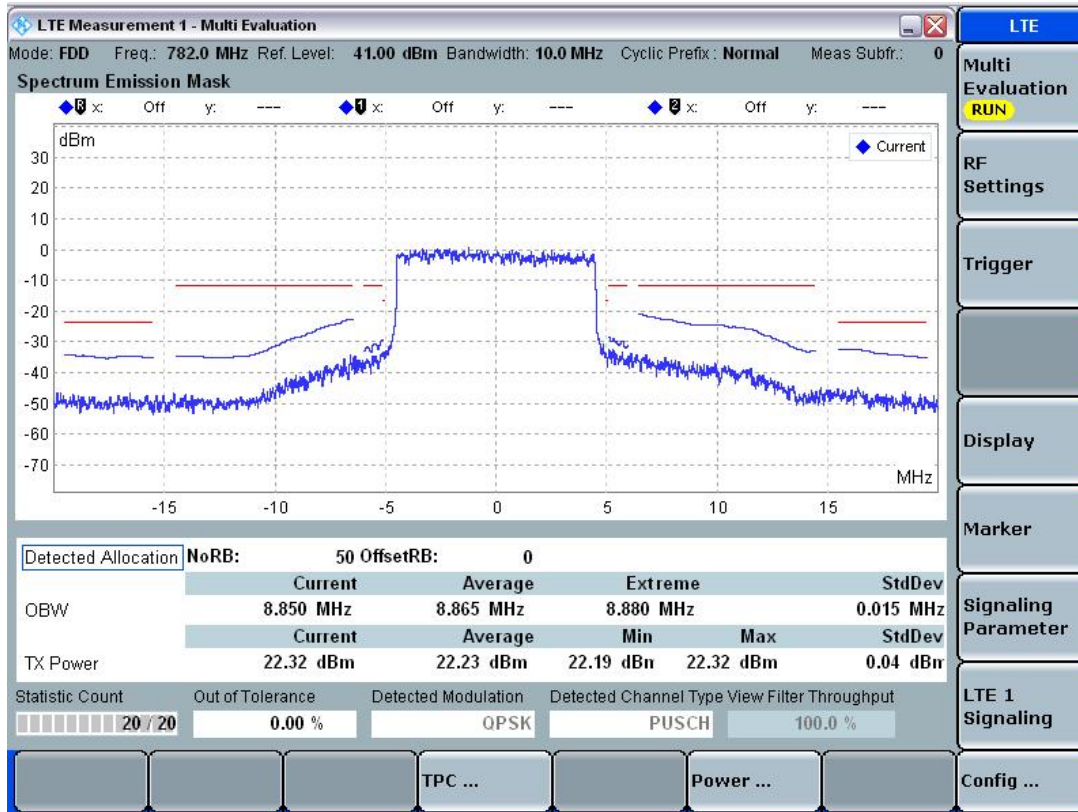

RB50, Offset0, 16QAM Plot

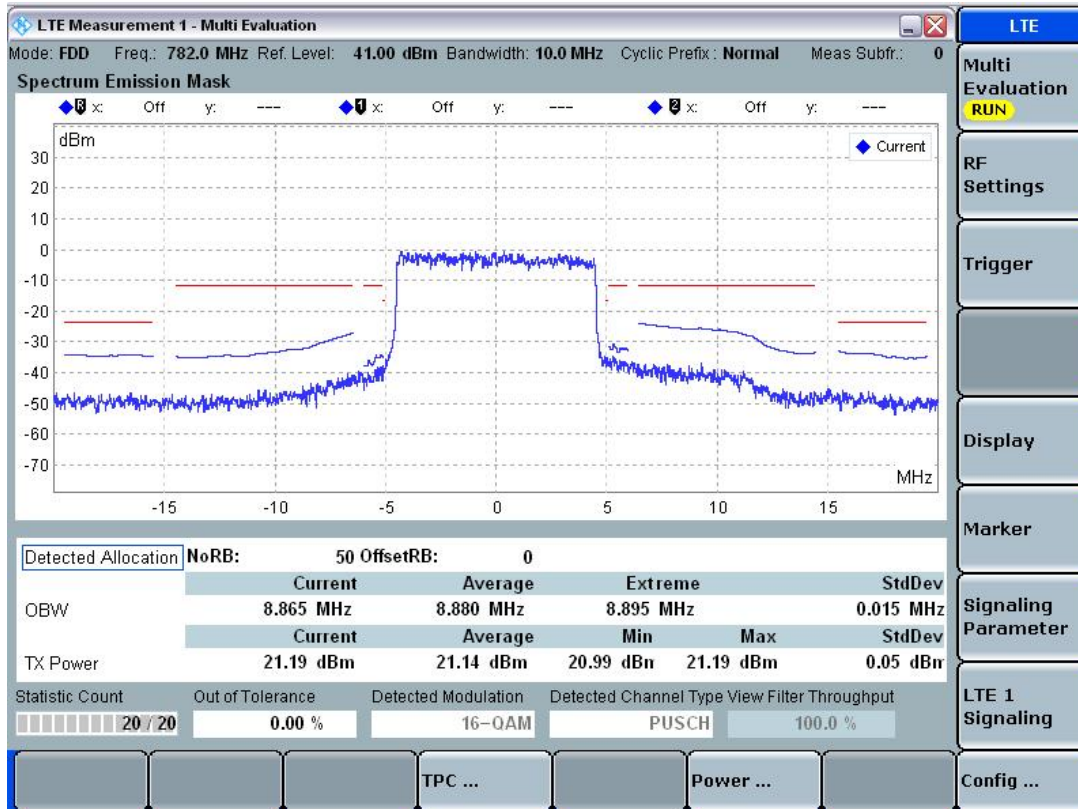

13. Mobile Hotspot Side for SAR Testing

13.1 SAR Test configurations

Mode	Back	Front	Left	Right	Bottom	Top
CDMA835/PCS1900	Yes	Yes	Yes	Yes	Yes	No
EVDO835/1900	Yes	Yes	Yes	Yes	No	Yes
LTE	Yes	Yes	Yes	Yes	No	Yes
WLAN	Yes	Yes	Yes	No	No	No

13.2 Antenna and Device Information

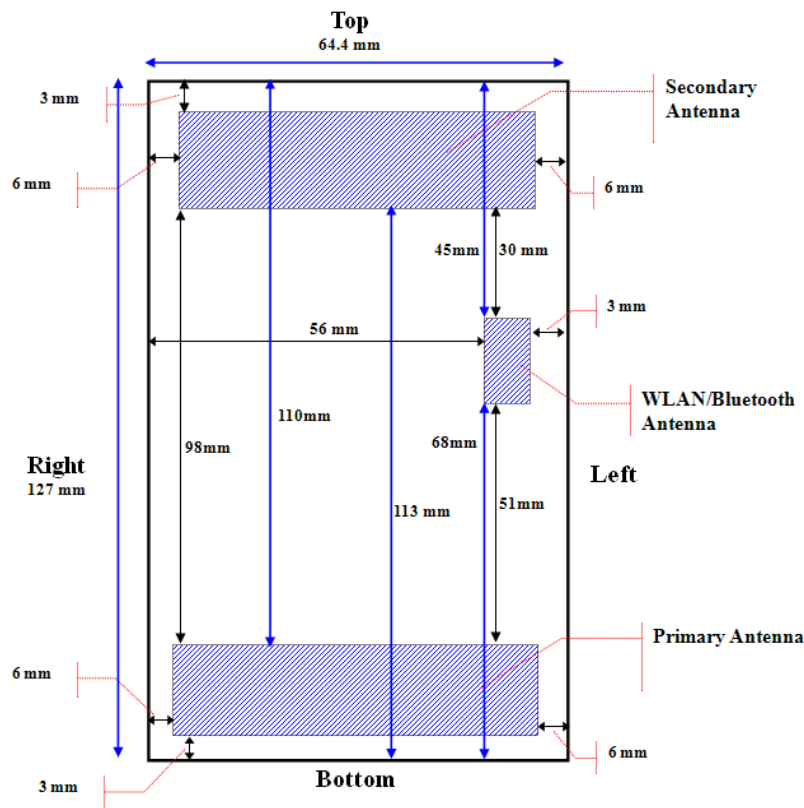

[Rear side View]

Note;

Per KDB 941225 D06 hotspot procedures, we performed the SAR testing at 1 cm from the top & bottom surfaces and also from side edges with a transmitting antenna ≤ 2.5 cm from an edge.

Primary antenna	Secondary/MIMO antenna
13.3mm x 46.7mm x 4.85mm	11.7mm x 51.6mm x 5.15mm
LTE band 13 (MIMO RX)	LTE band 13 (TX and RX)
CDMA 800/1900 : 1x (TX)	CDMA 800/1900 : 1x (RX)
CDMA 800/1900 : EVDO Rev. A (RX)	CDMA 800/1900 : EVDO Rev. A (TX, Diversity RX)

14. SAR Evaluation Considerations for Handsets with Multiple Transmitters and Antennas

14.1 SAR Evaluation Considerations

These procedures were followed according to FCC "SAR Evaluation Considerations for Handsets with Multiple Transmitters and Antennas", May 2008. The procedures are applicable to phones with built-in unlicensed transmitters, such as 802.11 a/b/g and Bluetooth devices.

	2.45	5.15 - 5.35	5.47 - 5.85	GHz
P_{Ref}	12	6	5	mW

Device output power should be rounded to the nearest mW to compare with values specified in this

Table. 14.1 Output Power Thresholds for Unlicensed Transmitters

	Individual Transmitter	Simultaneous Transmission
Licensed Transmitters	<u>Routine evaluation required</u>	SAR not required: <u>Unlicensed only</u>
Unlicensed Transmitters	<p><u>When there is no simultaneous transmission –</u></p> <ul style="list-style-type: none"> output ≤ 60/f: SAR not required output > 60/f: stand-alone SAR required <p><u>When there is simultaneous transmission – Stand-alone SAR not required when</u></p> <ul style="list-style-type: none"> output $\leq 2 \cdot P_{Ref}$ and antenna is ≥ 5.0 cm from other antennas output $\leq P_{Ref}$ and antenna is ≥ 2.5 cm from other antennas output $\leq P_{Ref}$ and antenna is < 2.5 cm from other antennas, each with either output power $\leq P_{Ref}$ or 1-g SAR < 1.2 W/kg <p><u>Otherwise stand-alone SAR is required</u></p> <p><u>When stand-alone SAR is required</u></p> <ul style="list-style-type: none"> test SAR on highest output channel for each wireless mode and exposure condition if SAR for highest output channel is $> 50\%$ of SAR limit, evaluate all channels according to normal procedures 	<ul style="list-style-type: none"> when stand-alone 1-g SAR is not required and antenna is ≥ 5 cm from other antennas <p><u>Licensed & Unlicensed</u></p> <ul style="list-style-type: none"> when the sum of the 1-g SAR is < 1.6 W/kg for all simultaneous transmitting antennas when SAR to peak location separation ratio of simultaneous transmitting antenna pair is < 0.3 <p>SAR required: <u>Licensed & Unlicensed</u></p> <p>antenna pairs with SAR to peak location separation ratio ≥ 0.3; test is only required for the configuration that results in the highest SAR in stand-alone configuration for each wireless mode and exposure condition</p> <p>Note: simultaneous transmission exposure conditions for head and body can be different for different style phones; therefore, different test requirements may apply</p>
Jaw, Mouth and Nose	<p><u>Flat phantom SAR required</u></p> <ul style="list-style-type: none"> when measurement is required in tight regions of SAM and it is not feasible or the results can be questionable due to probe tilt, calibration, positioning and orientation issues position rectangular and clam-shell phones according to flat phantom procedures and conduct SAR measurements for these specific locations 	When simultaneous transmission SAR testing is required, contact the FCC Laboratory for interim guidance.

Table. 14.2 SAR Evaluation Requirements for Cellphones with Multiple Transmitters

FCC ID: JYCAPACHE / BT Max. RF output power: 8.44 dBm (6.98 mW)

Antenna separation distance between Main and BT/ WLAN: 51 mm

Antenna separation distance between EVDO/LTE and BT/ WLAN: 30 mm

WLAN Max. RF output power: Wi-Fi 802.11b(16.58 dBm)/ Wi-Fi 802.11g (12.55 dBm) / Wi-Fi 802.11n (10.45 dBm)

Because the conducted output power level of the BT transmitter is less than $2 \cdot P_{ref}$, and the BT antenna is more than 5 cm from the Main antenna, neither simultaneous SAR nor stand-alone BT SAR are required for the EUT.

14.2 Simultaneous Transmission Possibilities

Simultaneous Tx Combination	Configuration	Head	Body-Worn	Hotspot
1	CDMA Voice	O	O	-
2	CDMA Voice + BT	-	O	-
3	EVDO Data	-	O	-
4	EVDO Data + BT	-	O	-
5	EVDO VoIP	O	-	-
6	EVDO VoIP + WLAN	O		-
7	EVDO VoIP + BT	-	O	-
8	LTE Data	-	O	-
9	LTE Data + BT	-	O	
10	LTE VoIP	O	-	-
11	LTE VoIP + BT	-	O	-
12	LTE VoIP + WLAN	O		-
13	WLAN/BT Data	-	O	-
14	WLAN/BT VoIP	O	-	-
15	CDMA Voice+ EVDO Data	O	-	-
16	CDMA Voice+ EVDO Data + BT	-	O	-
17	CDMA Voice+ EVDO Data + WLAN	O		O
18	CDMA Voice + LTE Data	O	-	-
19	CDMA Voice + LTE Data + BT	-	O	-
20	CDMA Voice + LTE Data + WLAN	O	-	O
21	CDMA Voice + WLAN	O	-	-
22	EVDO Data + WLAN	-	-	O
23	LTE Data + WLAN	-	-	O

Table 14.3 Simultaneous Transmission Possibilities

Note;

This device doesn't support simultaneous transmission for EVDO and LTE since they share the antenna.

14.3 SAR Summation Scenario

Below table represents CDMA + EVDO + WLAN, CDMA + LTE + WLAN for Head and Hotspot configurations. Other combinations for Head, Hotspot and Body-Worn configuration such as CDMA Voice+EVDO Data, CDMA Voice+LTE Data are also can be addressed in the same table.

CDMA + EVDO + WLAN (Held to Ear)

Simultaneous TX	configuration	CDMA835 SAR(W/kg)	EVDO835 SAR (W/kg)	WIFI SAR (W/kg)	ΣSAR (W/kg)	Simultaneous TX	configuration	PCS1900 SAR(W/kg)	EVDO835 SAR (W/kg)	WIFI SAR (W/kg)	ΣSAR (W/kg)
Head SAR	Right Cheek	0.371	0.48	0.084	0.935	Head SAR	Right Cheek	0.358	0.48	0.084	0.922
	Right Tilt	0.253	0.342	0.036	0.631		Right Tilt	0.176	0.342	0.036	0.554
	Left Cheek	0.319	0.598	0.261	1.178		Left Cheek	0.354	0.598	0.261	1.213
	Left Tilt	0.252	0.497	0.085	0.834		Left Tilt	0.151	0.497	0.085	0.733
Simultaneous TX	configuration	CDMA835 SAR(W/kg)	EVDO1900 SAR (W/kg)	WIFI SAR (W/kg)	ΣSAR (W/kg)	Simultaneous TX	configuration	PCS1900 SAR(W/kg)	EVD O1900 SAR (W/kg)	WIFI SAR (W/kg)	ΣSAR (W/kg)
Head SAR	Right Cheek	0.371	0.665	0.084	1.12	Head SAR	Right Cheek	0.358	0.665	0.084	1.107
	Right Tilt	0.253	0.765	0.036	1.054		Right Tilt	0.176	0.765	0.036	0.977
	Left Cheek	0.319	0.927	0.261	1.507		Left Cheek	0.354	0.927	0.261	1.542
	Left Tilt	0.252	1.05	0.085	1.387		Left Tilt	0.151	1.05	0.085	1.286

CDMA + LTE + WLAN (Held to Ear)

Simultaneous TX	configuration	CDMA835 SAR(W/kg)	LTE SAR (W/kg)	WIFI SAR (W/kg)	ΣSAR (W/kg)	Simultaneous TX	configuration	PCS1900 SAR(W/kg)	LTE SAR (W/kg)	WIFI SAR (W/kg)	ΣSAR (W/kg)
Head SAR	Right Cheek	0.371	0.265	0.084	0.72	Head SAR	Right Cheek	0.358	0.265	0.084	0.707
	Right Tilt	0.253	0.219	0.036	0.508		Right Tilt	0.176	0.219	0.036	0.431
	Left Cheek	0.319	0.321	0.261	0.901		Left Cheek	0.354	0.321	0.261	0.936
	Left Tilt	0.252	0.243	0.085	0.58		Left Tilt	0.151	0.243	0.085	0.479

CDMA + EVDO + WLAN (Hotspot 1.0 cm)

Simultaneous TX	configuration	CDMA835 SAR(W/kg)	EVDO835 SAR (W/kg)	WIFI SAR (W/kg)	ΣSAR (W/kg)	Simultaneous TX	configuration	PCS1900 SAR(W/kg)	EVDO835 SAR (W/kg)	WIFI SAR (W/kg)	ΣSAR (W/kg)
Body SAR	Back	0.654	0.67	0.088	1.412	Body SAR	Back	0.505	0.67	0.088	1.263
	Front	0.379	0.271	0.00145	0.65145		Front	0.45	0.271	0.00145	0.72245
	Right Edge	0.438	0.309	0.089	0.836		Right Edge	0.159	0.309	0.089	0.557
	Left Edge	0.352	0.25	-	0.602		Left Edge	0.185	0.25	-	0.435
	Top Edge	-	0.108	-	0.108		Top Edge	-	0.108	-	0.108
	Bottom Edge	0.116	-	-	0.116		Bottom Edge	0.55	-	-	0.55
Simultaneous TX	configuration	CDMA835 SAR(W/kg)	EVDO1900 SAR (W/kg)	WIFI SAR (W/kg)	ΣSAR (W/kg)	Simultaneous TX	configuration	PCS1900 SAR(W/kg)	EVD O1900 SAR (W/kg)	WIFI SAR (W/kg)	ΣSAR (W/kg)
Body SAR	Back	0.654	0.797	0.088	1.539	Body SAR	Back	0.505	0.797	0.088	1.39
	Front	0.379	0.295	0.002	0.676		Front	0.45	0.295	0.002	0.747
	Right Edge	0.438	0.172	0.089	0.699		Right Edge	0.159	0.172	0.089	0.42
	Left Edge	0.352	0.111	-	0.463		Left Edge	0.185	0.111	-	0.296
	Top Edge	-	0.526	-	0.526		Top Edge	-	0.526	-	0.526
	Bottom Edge	0.116	-	-	0.116		Bottom Edge	0.55	-	-	0.55

CDMA +LTE + WLAN (Hotspot 1.0 cm)

Simultaneous TX	configuration	CDMA835 SAR(W/kg)	LTE SAR (W/kg)	WIFI SAR (W/kg)	ΣSAR (W/kg)	Simultaneous TX	configuration	PCS1900 SAR(W/kg)	LTE SAR (W/kg)	WIFI SAR (W/kg)	ΣSAR (W/kg)
Body SAR	Back	0.654	0.442	0.088	1.184	Body SAR	Back	0.505	0.442	0.088	1.035
	Front	0.379	0.166	0.00145	0.54645		Front	0.45	0.166	0.00145	0.61745
	Right Edge	0.438	0.218	0.089	0.745		Right Edge	0.159	0.218	0.089	0.466
	Left Edge	0.352	0.161	-	0.513		Left Edge	0.185	0.161	-	0.346
	Top Edge	-	0.064	-	0.064		Top Edge	-	0.064	-	0.064
	Bottom Edge	0.116	-	-	0.116		Bottom Edge	0.55	-	-	0.55

15. SAR TEST DATA SUMMARY

15.1 Measurement Results (CDMA835 Head SAR)

Frequency		Modulation	Conducted Power (dBm)		Battery	Phantom Position	Antenna Type	SAR(mW/g)
MHz	Channel		Begin	End				
836.52	384 (Mid)	CDMA835	24.23	24.09	Standard	Left Ear	Intenna	0.319
836.52	384 (Mid)	CDMA835	24.23	24.22	Standard	Left Tilt 15°	Intenna	0.252
836.52	384 (Mid)	CDMA835	24.23	24.13	Standard	Right Ear	Intenna	0.371
836.52	384 (Mid)	CDMA835	24.23	24.23	Standard	Right Tilt 15°	Intenna	0.253
836.52	384 (Mid)	EVDO	24.32	24.19	Standard	Left Ear	Intenna	0.598
836.52	384 (Mid)	EVDO	24.32	24.41	Standard	Left Tilt 15°	Intenna	0.497
836.52	384 (Mid)	EVDO	24.32	24.30	Standard	Right Ear	Intenna	0.480
836.52	384 (Mid)	EVDO	24.32	24.32	Standard	Right Tilt 15°	Intenna	0.342
ANSI/ IEEE C95.1 - 1992– Safety Limit						Head		
Spatial Peak						1.6 W/kg (mW/g)		
Uncontrolled Exposure/ General Population						<small>Averaged over 1 gram</small>		

NOTES:

- The test data reported are the worst-case SAR value with the antenna-head position set in a typical configuration. Test procedures used are according to FCC/OET Bulletin 65, Supplement C [July 2001].
- All modes of operation were investigated and the worst-case are reported.
- Measured Depth of Simulating Tissue is 15.0 cm ± 0.2 cm.
- Tissue parameters and temperatures are listed on the SAR plot.
- Battery Type Standard Extended Slim
Batteries are fully charged for all readings.
- Test Signal Call Mode Manual Test cord Base Station Simulator
- Justification for reduced test configurations: per FCC/OET Supplement C (July, 2001), if the SAR measured at the middle channel for each test configuration (Left, right, cheek/touch, tilt/ear, extended and retracted) is at least 3.0 dB lower than the SAR limit, testing at the high and low channels is optional for such test configuration(s).
- EVDO SAR was tested under EVDO Rev.0 RTAP.

15.2 Measurement Results (PCS1900 Head SAR)

Frequency		Modulation	Conducted Power (dBm)		Battery	Phantom Position	Antenna Type	SAR(mW/g)
MHz	Channel		Begin	End				
1 880.00	600 (Mid)	PCS1900	24.42	24.23	Standard	Left Ear	Intenna	0.354
1 880.00	600 (Mid)	PCS1900	24.42	24.42	Standard	Left Tilt 15°	Intenna	0.151
1 880.00	600 (Mid)	PCS1900	24.42	24.41	Standard	Right Ear	Intenna	0.358
1 880.00	600 (Mid)	PCS1900	24.42	24.40	Standard	Right Tilt 15°	Intenna	0.176
1 851.25	25 (Low)	EVDO	24.28	24.36	Standard	Left Ear	Intenna	0.844
1 880.00	600 (Mid)	EVDO	24.32	24.18	Standard	Left Ear	Intenna	0.885
1 908.75	1175 (High)	EVDO	24.31	24.40	Standard	Left Ear	Intenna	0.927
1 851.25	25 (Low)	EVDO	24.28	24.39	Standard	Left Tilt 15°	Intenna	0.856
1 880.00	600 (Mid)	EVDO	24.32	24.33	Standard	Left Tilt 15°	Intenna	1.05
1 908.75	1175 (High)	EVDO	24.31	24.44	Standard	Left Tilt 15°	Intenna	0.910
1 880.00	600 (Mid)	EVDO	24.32	24.34	Standard	Right Ear	Intenna	0.665
1 880.00	600 (Mid)	EVDO	24.32	24.33	Standard	Right Tilt 15°	Intenna	0.765
ANSI/ IEEE C95.1 - 1992– Safety Limit Spatial Peak Uncontrolled Exposure/ General Population						Head 1.6 W/kg (mW/g) Averaged over 1 gram		

NOTES:

- The test data reported are the worst-case SAR value with the antenna-head position set in a typical configuration. Test procedures used are according to FCC/OET Bulletin 65, Supplement C [July 2001].
- All modes of operation were investigated and the worst-case are reported.
- Measured Depth of Simulating Tissue is 15.0 cm ± 0.2 cm.
- Tissue parameters and temperatures are listed on the SAR plot.
- Battery Type Standard Extended Slim
Batteries are fully charged for all readings.
- Test Signal Call Mode Manual Test cord Base Station Simulator
- Justification for reduced test configurations: per FCC/OET Supplement C (July, 2001), if the SAR measured at the middle channel for each test configuration (Left, right, cheek/touch, tilt/ear, extended and retracted) is at least 3.0 dB lower than the SAR limit, testing at the high and low channels is optional for such test configuration(s).
- EVDO SAR was tested under EVDO Rev.0 RTAP.

15.3 Measurement Results (LTE Head SAR QPSK)

Frequency		Modulation	Conducted Power (dBm)		RB Size	RB Offset	Phantom Position	Antenna Type	SAR(m W/g)	MPR
MHz	Channe		Begin	End						
782	23230	QPSK	23.32	23.25	1	0	Left Ear	Intenna	0.271	0
782	23230	QPSK	23.32	23.37	1	0	Left Tilt 15°	Intenna	0.243	0
782	23230	QPSK	23.23	23.31	1	49	Left Ear	Intenna	0.321	0
782	23230	QPSK	23.23	23.17	1	49	Left Tilt 15°	Intenna	0.280	0
782	23230	QPSK	22.31	22.20	25	13	Left Ear	Intenna	0.229	1
782	23230	QPSK	22.31	22.28	25	13	Left Tilt 15°	Intenna	0.193	1
782	23230	QPSK	23.32	23.37	1	0	Right Ear	Intenna	0.221	0
782	23230	QPSK	23.32	23.39	1	0	Right Tilt 15°	Intenna	0.190	0
782	23230	QPSK	23.23	23.23	1	49	Right Ear	Intenna	0.265	0
782	23230	QPSK	23.23	23.33	1	49	Right Tilt 15°	Intenna	0.219	0
782	23230	QPSK	22.31	22.31	25	13	Right Ear	Intenna	0.189	1
782	23230	QPSK	22.31	22.19	25	13	Right Tilt 15°	Intenna	0.150	1
ANSI/ IEEE C95.1 - 1992– Safety Limit Spatial Peak Uncontrolled Exposure/ General Population						Head 1.6 W/kg (mW/g) Averaged over 1 gram				

NOTES:

- The test data reported are the worst-case SAR value with the antenna-head position set in a typical configuration. Test procedures used are according to FCC/OET Bulletin 65, Supplement C [July 2001].
- All modes of operation were investigated and the worst-case are reported.
- Measured Depth of Simulating Tissue is 15.0 cm ± 0.2 cm.
- Tissue parameters and temperatures are listed on the SAR plot.
- Battery Type Standard Extended Slim
Batteries are fully charged for all readings.
- Test Signal Call Mode Manual Test cord Base Station Simulator
- Justification for reduced test configurations: per FCC/OET Supplement C (July, 2001), if the SAR measured at the middle channel for each test configuration (Left, right, cheek/touch, tilt/ear, extended and retracted) is at least 3.0 dB lower than the SAR limit, testing at the high and low channels is optional for such test configuration(s).
- KDB 941225 D05 SAR for LTE Devices v01 was followed.

15.4 Measurement Results (LTE Head SAR 16QAM)

Frequency		Modulation	Conducted Power (dBm)		RB Size	RB Offset	Phantom Position	Antenna Type	SAR(m W/g)	MPR
MHz	Channe		Begin	End						
782	23230	16QAM	22.38	22.40	1	0	Left Ear	Intenna	0.209	1
782	23230	16QAM	22.38	22.43	1	0	Left Tilt 15°	Intenna	0.184	1
782	23230	16QAM	22.25	22.36	1	49	Left Ear	Intenna	0.264	1
782	23230	16QAM	22.25	22.30	1	49	Left Tilt 15°	Intenna	0.227	1
782	23230	16QAM	21.18	21.26	25	13	Left Ear	Intenna	0.194	2
782	23230	16QAM	21.18	21.18	25	13	Left Tilt 15°	Intenna	0.166	2
782	23230	16QAM	22.38	22.35	1	0	Right Ear	Intenna	0.172	1
782	23230	16QAM	22.38	22.40	1	0	Right Tilt 15°	Intenna	0.146	1
782	23230	16QAM	22.25	22.23	1	49	Right Ear	Intenna	0.219	1
782	23230	16QAM	22.25	22.09	1	49	Right Tilt 15°	Intenna	0.175	1
782	23230	16QAM	21.18	21.26	25	13	Right Ear	Intenna	0.160	2
782	23230	16QAM	21.18	21.18	25	13	Right Tilt 15°	Intenna	0.128	2
ANSI/ IEEE C95.1 - 1992– Safety Limit Spatial Peak Uncontrolled Exposure/ General Population						Head 1.6 W/kg (mW/g) Averaged over 1 gram				

NOTES:

- 1 The test data reported are the worst-case SAR value with the antenna-head position set in a typical configuration. Test procedures used are according to FCC/OET Bulletin 65, Supplement C [July 2001].
- 2 All modes of operation were investigated and the worst-case are reported.
- 3 Measured Depth of Simulating Tissue is 15.0 cm ± 0.2 cm.
- 4 Tissue parameters and temperatures are listed on the SAR plot.
- 5 Battery Type Standard Extended Slim
Batteries are fully charged for all readings.
- 6 Test Signal Call Mode Manual Test cord Base Station Simulator
- 7 Justification for reduced test configurations: per FCC/OET Supplement C (July, 2001), if the SAR measured at the middle channel for each test configuration (Left, right, cheek/touch, tilt/ear, extended and retracted) is at least 3.0 dB lower than the SAR limit, testing at the high and low channels is optional for such test configuration(s).
- 8 KDB 941225 D05 SAR for LTE Devices v01 was followed.

15.5 Measurement Results (802.11b/g/n Head)

Frequency		Modulation	Conducted Power (dBm)		Battery	Phantom Position	Antenna Type	SAR(mW/g)
MHz	Channel		Begin	End				
2 437	6 (Mid)	802.11b	16.58	16.60	Standard	Left Ear	Intenna	0.261
2 437	6 (Mid)	802.11b	16.58	16.51	Standard	Left Tilt 15°	Intenna	0.085
2 437	6 (Mid)	802.11b	16.58	16.59	Standard	Right Ear	Intenna	0.084
2 437	6 (Mid)	802.11b	16.58	16.60	Standard	Right Tilt 15	Intenna	0.036
ANSI/ IEEE C95.1 - 1992– Safety Limit						Head		
Spatial Peak						1.6 W/kg (mW/g)		
Uncontrolled Exposure/ General Population						<small>Averaged over 1 gram</small>		

NOTES:

- The test data reported are the worst-case SAR value with the antenna-head position set in a typical configuration. Test procedures used are according to FCC/OET Bulletin 65, Supplement C [July 2001].
- All modes of operation were investigated and the worst-case are reported.
- Measured Depth of Simulating Tissue is 15.0 cm ± 0.2 cm.
- Tissue parameters and temperatures are listed on the SAR plot.
- Battery Type Standard Extended Slim
Batteries are fully charged for all readings.
- Test Signal Call Mode Manual Test cord Base Station Simulator
- IEEE 802.11g(including 802.11n) SAR testing is required when the conducted powers are equal to or greater than 0.25 dB Than the conducted powers in IEEE 802.11b.

15.6 Measurement Results (CDMA835 Hotspot SAR)

Frequency		Modulation	Conducted Power (dBm)		Configuration	Separation Distance	SAR(mW/g)
MHz	Channel		Begin	End			
836.52	384 (Mid)	CDMA835	24.19	24.15	Front	1.0 cm	0.379
836.52	384 (Mid)	CDMA835	24.19	24.18	Rear	1.0 cm	0.654
836.52	384 (Mid)	CDMA835	24.19	24.13	Left	1.0 cm	0.352
836.52	384 (Mid)	CDMA835	24.19	24.11	Right	1.0 cm	0.438
836.52	384 (Mid)	CDMA835	24.19	24.06	Bottom	1.0 cm	0.116
836.52	384 (Mid)	EVDO	24.32	24.35	Front	1.0 cm	0.271
836.52	384 (Mid)	EVDO	24.32	24.32	Rear	1.0 cm	0.670
836.52	384 (Mid)	EVDO	24.32	24.27	Left	1.0 cm	0.250
836.52	384 (Mid)	EVDO	24.32	24.39	Right	1.0 cm	0.309
836.52	384 (Mid)	EVDO	24.32	24.40	Top	1.0 cm	0.108
ANSI/ IEEE C95.1 - 1992– Safety Limit Spatial Peak Uncontrolled Exposure/ General Population						Body 1.6 W/kg (mW/g) Averaged over 1 gram	

NOTES:

- The test data reported are the worst-case SAR value with the antenna-head position set in a typical configuration. Test procedures used are according to FCC/OET Bulletin 65, Supplement C [July 2001].
- All modes of operation were investigated and the worst-case are reported.
- Measured Depth of Simulating Tissue is 15.0 cm ± 0.2 cm.
- Tissue parameters and temperatures are listed on the SAR plot.
- Battery Type Standard Extended Slim
Batteries are fully charged for all readings.
- Test Signal Call Mode Manual Test cord Base Station Simulator
- EVDO SAR was tested under EVDO Rev.0 RTAP.
- Test Configuration With Holster Without Holster
- Justification for reduced test configurations: per FCC/OET Supplement C (July, 2001), if the SAR measured at the middle channel for each test configuration (Left, right, cheek/touch, tilt/ear, extended and retracted) is at least 3.0 dB lower than the SAR limit, testing at the high and low channels is optional for such test configuration(s).

15.7 Measurement Results (PCS1900 Hotspot SAR)

Frequency		Modulation	Conducted Power (dBm)		Configuration	Separation Distance	SAR(mW/g)
MHz	Channel		Begin	End			
1 880.00	600 (Mid)	PCS1900	24.37	24.30	Front	1.0 cm	0.450
1 880.00	600 (Mid)	PCS1900	24.37	24.34	Rear	1.0 cm	0.505
1 880.00	600 (Mid)	PCS1900	24.37	24.32	Left	1.0 cm	0.185
1 880.00	600 (Mid)	PCS1900	24.37	24.47	Right	1.0 cm	0.159
1 880.00	600 (Mid)	PCS1900	24.37	24.36	Bottom	1.0 cm	0.550
1 880.00	600 (Mid)	EVDO	24.32	24.35	Front	1.0 cm	0.295
1 880.00	600 (Mid)	EVDO	24.32	24.25	Rear	1.0 cm	0.797
1 880.00	600 (Mid)	EVDO	24.32	24.34	Left	1.0 cm	0.111
1 880.00	600 (Mid)	EVDO	24.32	24.40	Right	1.0 cm	0.172
1 880.00	600 (Mid)	EVDO	24.32	24.22	Top	1.0 cm	0.526
ANSI/ IEEE C95.1 - 1992– Safety Limit Spatial Peak Uncontrolled Exposure/ General Population						Body 1.6 W/kg (mW/g) Averaged over 1 gram	

NOTES:

- 1 The test data reported are the worst-case SAR value with the antenna-head position set in a typical configuration. Test procedures used are according to FCC/OET Bulletin 65, Supplement C [July 2001].
- 2 All modes of operation were investigated and the worst-case are reported.
- 3 Measured Depth of Simulating Tissue is 15.0 cm ± 0.2 cm.
- 4 Tissue parameters and temperatures are listed on the SAR plot.
- 5 Battery Type Standard Extended Slim
Batteries are fully charged for all readings.
- 6 Test Signal Call Mode Manual Test cord Base Station Simulator
- 7 EVDO SAR was tested under EVDO Rev.0 RTAP.
- 8 Test Configuration With Holster Without Holster
- 9 Justification for reduced test configurations: per FCC/OET Supplement C (July, 2001), if the SAR measured at the middle channel for each test configuration (Left, right, cheek/touch, tilt/ear, extended and retracted) is at least 3.0 dB lower than the SAR limit, testing at the high and low channels is optional for such test configuration(s).

15.8 Measurement Results (802.11b/g/n Hotspot SAR)

Frequency		Modulation	Conducted Power (dBm)		Configuration	Separation Distance	Data Rate	SAR(mW/g)
MHz	Channel		Begin	End				
2 437	6 (Mid)	802.11b	16.58	16.65	Front	1.0 cm	1 Mbps	0.00145
2 437	6 (Mid)	802.11b	16.58	16.69	Rear	1.0 cm	1 Mbps	0.088
2 437	6 (Mid)	802.11b	16.58	16.55	Left	1.0 cm	1 Mbps	0.089
ANSI/ IEEE C95.1 1992 – Safety Limit						Body		
Spatial Peak						1.6 W/kg (mW/g)		
Uncontrolled Exposure/ General Population						<small>Averaged over 1 gram</small>		

NOTES:

- 1 The test data reported are the worst-case SAR value with the antenna-head position set in a typical configuration. Test procedures used are according to FCC/OET Bulletin 65, Supplement C [July 2001].
- 2 All modes of operation were investigated and the worst-case are reported.
- 3 Measured Depth of Simulating Tissue is 15.0 cm ± 0.2 cm.
- 4 Tissue parameters and temperatures are listed on the SAR plot.
- 5 Battery Type Standard Extended Slim
Batteries are fully charged for all readings.
- 6 Test Signal Call Mode Manual Test code Base Station Simulator
- 7 IEEE 802.11g(including 802.11n) SAR testing is required when the conducted powers are equal to or greater than 0.25 dB Than the conducted powers in IEEE 802.11b.

15.9 Measurement Results (LTE Body SAR QPSK)

Frequency		Modulation	Conducted Power (dBm)		Configuration	RB Size	RB Offset	Separation Distance	Antenna Type	SAR(mW/g)	MPR
MHz	Chann		Begin	End							
782	23230	QPSK	23.23	23.25	Front	1	0	1.0 cm	Intenna	0.147	0
782	23230	QPSK	23.32	23.34	Front	1	49	1.0 cm	Intenna	0.166	0
782	23230	QPSK	22.31	22.32	Front	25	13	1.0 cm	Intenna	0.119	1
782	23230	QPSK	23.23	23.20	Rear	1	0	1.0 cm	Intenna	0.428	0
782	23230	QPSK	23.32	23.27	Rear	1	49	1.0 cm	Intenna	0.442	0
782	23230	QPSK	22.31	22.32	Rear	25	13	1.0 cm	Intenna	0.335	1
782	23230	QPSK	23.23	0.056	Left	1	0	1.0 cm	Intenna	0.139	0
782	23230	QPSK	23.32	0.009	Left	1	49	1.0 cm	Intenna	0.161	0
782	23230	QPSK	22.31	22.26	Left	25	13	1.0 cm	Intenna	0.116	1
782	23230	QPSK	23.23	23.16	Right	1	0	1.0 cm	Intenna	0.192	0
782	23230	QPSK	23.32	23.30	Right	1	49	1.0 cm	Intenna	0.218	0
782	23230	QPSK	22.31	22.34	Right	25	13	1.0 cm	Intenna	0.150	1
782	23230	QPSK	23.23	23.27	Top	1	0	1.0 cm	Intenna	0.052	0
782	23230	QPSK	23.32	23.30	Top	1	49	1.0 cm	Intenna	0.058	0
782	23230	QPSK	22.31	22.43	Top	25	13	1.0 cm	Intenna	0.042	1
ANSI/IEEE C95.1 - 1992- Safety Limit Spatial Peak Uncontrolled Exposure/ General Population							Body 1.6 W/kg (mW/g) Averaged over 1 gram				

NOTES:

- The test data reported are the worst-case SAR value with the antenna-head position set in a typical configuration. Test procedures used are according to FCC/OET Bulletin 65, Supplement C [July 2001].
- All modes of operation were investigated and the worst-case are reported.
- Measured Depth of Simulating Tissue is 15.0 cm ± 0.2 cm.
- Tissue parameters and temperatures are listed on the SAR plot.
- Battery Type Standard Extended Slim
Batteries are fully charged for all readings.
- Test Signal Call Mode Manual Test cord Base Station Simulator
- Justification for reduced test configurations: per FCC/OET Supplement C (July, 2001), if the SAR measured at the middle channel for each test configuration (Left, right, cheek/touch, tilt/ear, extended and retracted) is at least 3.0 dB lower than the SAR limit, testing at the high and low channels is optional for such test configuration(s).
- KDB 941225 D05 SAR for LTE Devices v01 was followed.

15.10 Measurement Results (LTE Body SAR 16QAM)

Frequency		Modulation	Conducted Power (dBm)		Configuration	RB Size	RB Offset	Separation Distance	Antenna Type	SAR(mW/g)	MPR
MHz	Chann		Begin	End							
782	23230	16QAM	22.38	22.36	Front	1	0	1.0 cm	Intenna	0.116	1
782	23230	16QAM	22.25	22.26	Front	1	49	1.0 cm	Intenna	0.141	1
782	23230	16QAM	21.18	21.25	Front	25	13	1.0 cm	Intenna	0.101	2
782	23230	16QAM	22.38	22.37	Rear	1	0	1.0 cm	Intenna	0.428	1
782	23230	16QAM	22.25	22.27	Rear	1	49	1.0 cm	Intenna	0.387	1
782	23230	16QAM	21.18	21.19	Rear	25	13	1.0 cm	Intenna	0.283	2
782	23230	16QAM	22.38	22.40	Left	1	0	1.0 cm	Intenna	0.118	1
782	23230	16QAM	22.25	22.21	Left	1	49	1.0 cm	Intenna	0.139	1
782	23230	16QAM	21.18	21.19	Left	25	13	1.0 cm	Intenna	0.098	2
782	23230	16QAM	22.38	22.40	Right	1	0	1.0 cm	Intenna	0.152	1
782	23230	16QAM	22.25	22.29	Right	1	49	1.0 cm	Intenna	0.191	1
782	23230	16QAM	21.18	21.25	Right	25	13	1.0 cm	Intenna	0.138	2
782	23230	16QAM	22.38	22.44	Top	1	0	1.0 cm	Intenna	0.04	1
782	23230	16QAM	22.25	22.18	Top	1	49	1.0 cm	Intenna	0.064	1
782	23230	16QAM	21.18	21.20	Top	25	13	1.0 cm	Intenna	0.035	2
ANSI/ IEEE C95.1 - 1992– Safety Limit Spatial Peak Uncontrolled Exposure/ General Population						Body 1.6 W/kg (mW/g) Averaged over 1 gram					

NOTES:

- The test data reported are the worst-case SAR value with the antenna-head position set in a typical configuration. Test procedures used are according to FCC/OET Bulletin 65, Supplement C [July 2001].
- All modes of operation were investigated and the worst-case are reported.
- Measured Depth of Simulating Tissue is 15.0 cm ± 0.2 cm.
- Tissue parameters and temperatures are listed on the SAR plot.
- Battery Type Standard Extended Slim
Batteries are fully charged for all readings.
- Test Signal Call Mode Manual Test cord Base Station Simulator
- Justification for reduced test configurations: per FCC/OET Supplement C (July, 2001), if the SAR measured at the middle channel for each test configuration (Left, right, cheek/touch, tilt/ear, extended and retracted) is at least 3.0 dB lower than the SAR limit, testing at the high and low channels is optional for such test configuration(s).
- KDB 941225 D05 SAR for LTE Devices v01 was followed.

16. CONCLUSION

The SAR measurement indicates that the EUT complies with the RF radiation exposure limits of the ANSI/IEEE C95.1 1992.

These measurements are taken to simulate the RF effects exposure under worst-case conditions. Precise laboratory measures were taken to assure repeatability of the tests.

17. REFERENCES

- [1] Federal Communications Commission, OET Bulletin 65 (Edition 97-01), Supplement C (Edition 01-01), Evaluating Compliance with FCC Guidelines for Human Exposure to Radio frequency Electromagnetic Fields, July 2001.
- [2] IEEE Standards Coordinating Committee 34 – IEEE Std. 1528-2003, IEE Recommended Practice or Determining the Peak Spatial-Average Specific Absorption Rate (SAR) in the Human Body from Wireless Communications Devices.
- [3] Federal Communications Commission, ET Docket 93-62, Guidelines for Evaluating the Environmental Effects of Radio frequency Radiation, Aug. 1996.
- [4] ANSI/IEEE C95.1 - 1991, American National Standard safety levels with respect to human exposure to radio frequency electromagnetic fields, 300 kHz to 100 GHz, New York: IEEE, Aug. 1992
- [5] ANSI/IEEE C95.3 - 1991, IEEE Recommended Practice for the Measurement of Potentially Hazardous Electromagnetic Fields - RF and Microwave, New York: IEEE, 1992.
- [6] NCRP, National Council on Radiation Protection and Measurements, Biological Effects and Exposure Criteria for Radio Frequency Electromagnetic Fields, NCRP Report No. 86, 1986. Reprinted Feb. 1995.
- [7] T. Schmid, O. Egger, N. Kuster, Automated E-field scanning system for dosimetric assessments, IEEE Transaction on Microwave Theory and Techniques, vol. 44, Jan. 1996, pp. 105-113.
- [8] K. Pokovic, T. Schmid, N. Kuster, Robust setup for precise calibration of E-field probes in tissue simulating liquids at mobile communications frequencies, ICECOM97, Oct. 1997, pp. 120-124.
- [9] K. Pokovic, T. Schmid, and N. Kuster, E-field Probe with improved isotropy in brain simulating liquids, Proceedings of the ELMAR, Zadar, Croatia, June 23-25, 1996, pp. 172-175.
- [10] Schmid & Partner Engineering AG, Application Note: Data Storage and Evaluation, June 1998, p2.
- [11] V. Hombach, K. Meier, M. Burkhardt, E. Kuhn, N. Kuster, The Dependence of EM Energy Absorption upon Human Head Modeling at 900 MHz, IEEE Transaction on Microwave Theory and Techniques, vol. 44 no. 10, Oct. 1996, pp. 1865-1873.
- [12] N. Kuster and Q. Balzano, Energy absorption mechanism by biological bodies in the near field of dipole antennas above 300 MHz, IEEE Transaction on Vehicular Technology, vol. 41, no. 1, Feb. 1992, pp. 17-23.
- [13] G. Hartsgrove, A. Kraszewski, A. Surowiec, Simulated Biological Materials for Electromagnetic Radiation Absorption Studies, University of Ottawa, Bioelectro magnetics, Canada: 1987, pp. 29-36.
- [14] Q. Balzano, O. Garay, T. Manning Jr., Electromagnetic Energy Exposure of Simulated Users of Portable Cellular Telephones, IEEE Transactions on Vehicular Technology, vol. 44, no.3, Aug. 1995.
- [15] W. Gander, Computer mathematick, Birkhaeuser, Basel, 1992.
- [16] W.H. Press, S.A. Teukolsky, W.T. Vetterling, and B.P. Flannery, Numerical Receptions in C, The Art of Scientific Computing, Second edition, Cambridge University Press, 1992.
- [17] Federal Communications Commission, OET Bulletin 65, Evaluating Compliance with FCC Guidelines for Human Exposure to Radiofrequency Electromagnetic Fields. Supplement C, Dec. 1997.
- [18] N. Kuster, R. Kastle, T. Schmid, Dosimetric evaluation of mobile communications equipment with known precision, IEEE Transaction on Communications, vol. E80-B, no. 5, May 1997, pp. 645-652.
- [19] CENELEC CLC/SC111B, European Prestandard (prENV 50166-2), Human Exposure to Electromagnetic Fields High-frequency: 10 kHz-300 GHz, Jan. 1995.
- [20] Prof. Dr. Niels Kuster, ETH, Eidgenössische Technische Hochschule Zürich, Dosimetric Evaluation of the Cellular Phone.
- [21] SAR Evaluation of Handsets with Multiple Transmitters and Antennas #648474.
- [22] SAR Measurement Procedure for 802.11 a/b/g Transmitters #KDB 248227.

Attachment 1. – SAR Test Plots

Test Laboratory: HCT CO., LTD
EUT Type: CDMA/LTE Phone with Bluetooth & WLAN
Liquid Temperature: 21.3 °C
Ambient Temperature: 21.5 °C
Test Date: Jun.08, 2011

DUT: ADR8995; Type: Bar; Serial: #1

Communication System: CDMA 835MHz FCC; Frequency: 836.52 MHz; Duty Cycle: 1:1
Medium parameters used (interpolated): $f = 836.52$ MHz; $\sigma = 0.889$ mho/m; $\epsilon_r = 41.4$; $\rho = 1000$ kg/m³
Phantom section: Left Section ; Measurement SW: DASY4, V4.7 Build 71; Postprocessing SW: SEMCAD, V1.8 Build 184

DASY4 Configuration:

- Probe: ES3DV3 - SN3161; ConvF(5.84, 5.84, 5.84); Calibrated: 2011-03-17
- Sensor-Surface: 4mm (Mechanical Surface Detection)
- Electronics: DAE3 Sn466; Calibrated: 2011-03-01
- Phantom: 835/900 Phantom ; Type: SAM

Left touch 384/Area Scan (51x91x1): Measurement grid: dx=15mm, dy=15mm

[Info: Interpolated medium parameters used for SAR evaluation.](#)

MMaximum value of SAR (interpolated) = 0.337 mW/g

Left touch 384/Zoom Scan (5x5x7)/Cube 0: Measurement grid: dx=8mm, dy=8mm, dz=5mm

Reference Value = 6.71 V/m; Power Drift = -0.141 dB

Peak SAR (extrapolated) = 0.395 W/kg

SAR(1 g) = 0.319 mW/g; SAR(10 g) = 0.241 mW/g

[Info: Interpolated medium parameters used for SAR evaluation.](#)

MMaximum value of SAR (measured) = 0.334 mW/g

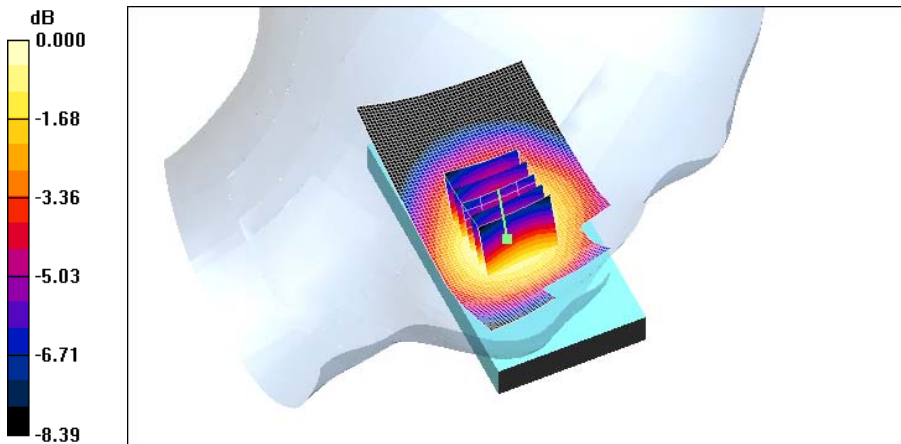

Test Laboratory: HCT CO., LTD
EUT Type: CDMA/LTE Phone with Bluetooth & WLAN
Liquid Temperature: 21.3 °C
Ambient Temperature: 21.5 °C
Test Date: Jun.08, 2011

DUT: ADR8995; Type: Bar; Serial: #1

Communication System: CDMA 835MHz FCC; Frequency: 836.52 MHz; Duty Cycle: 1:1
Medium parameters used (interpolated): $f = 836.52$ MHz; $\sigma = 0.889$ mho/m; $\epsilon_r = 41.4$; $\rho = 1000$ kg/m³
Phantom section: Left Section ; Measurement SW: DASY4, V4.7 Build 71; Postprocessing SW: SEMCAD, V1.8 Build 184

DASY4 Configuration:

- Probe: ES3DV3 - SN3161; ConvF(5.84, 5.84, 5.84); Calibrated: 2011-03-17
- Sensor-Surface: 4mm (Mechanical Surface Detection)
- Electronics: DAE3 Sn466; Calibrated: 2011-03-01
- Phantom: 835/900 Phantom ; Type: SAM

Left tilt 384/Area Scan (51x91x1): Measurement grid: dx=15mm, dy=15mm

[Info: Interpolated medium parameters used for SAR evaluation.](#)

MMaximum value of SAR (interpolated) = 0.261 mW/g

Left tilt 384/Zoom Scan (5x5x7)/Cube 0: Measurement grid: dx=8mm, dy=8mm, dz=5mm

Reference Value = 11.7 V/m; Power Drift = -0.008 dB

Peak SAR (extrapolated) = 0.306 W/kg

SAR(1 g) = 0.252 mW/g; SAR(10 g) = 0.196 mW/g

[Info: Interpolated medium parameters used for SAR evaluation.](#)

MMaximum value of SAR (measured) = 0.264 mW/g

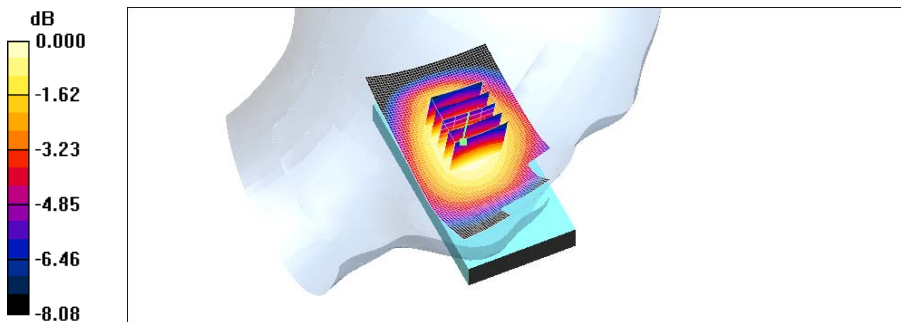

Test Laboratory: HCT CO., LTD
EUT Type: CDMA/LTE Phone with Bluetooth & WLAN
Liquid Temperature: 21.3 °C
Ambient Temperature: 21.5 °C
Test Date: Jun.08, 2011

DUT: ADR8995; Type: Bar; Serial: #1

Communication System: CDMA 835MHz FCC; Frequency: 836.52 MHz; Duty Cycle: 1:1
Medium parameters used (interpolated): $f = 836.52$ MHz; $\sigma = 0.889$ mho/m; $\epsilon_r = 41.4$; $\rho = 1000$ kg/m³
Phantom section: Right Section ; Measurement SW: DASY4, V4.7 Build 71; Postprocessing SW: SEMCAD, V1.8 Build 184

DASY4 Configuration:

- Probe: ES3DV3 - SN3161; ConvF(5.84, 5.84, 5.84); Calibrated: 2011-03-17
- Sensor-Surface: 4mm (Mechanical Surface Detection)
- Electronics: DAE3 Sn466; Calibrated: 2011-03-01
- Phantom: 835/900 Phantom ; Type: SAM

Right touch 384/Area Scan (51x91x1): Measurement grid: dx=15mm, dy=15mm

[Info: Interpolated medium parameters used for SAR evaluation.](#)

MMaximum value of SAR (interpolated) = 0.393 mW/g

Right touch 384/Zoom Scan (5x5x7)/Cube 0: Measurement grid: dx=8mm, dy=8mm, dz=5mm

Reference Value = 7.59 V/m; Power Drift = -0.102 dB

Peak SAR (extrapolated) = 0.476 W/kg

SAR(1 g) = 0.371 mW/g; SAR(10 g) = 0.280 mW/g

[Info: Interpolated medium parameters used for SAR evaluation.](#)

MMaximum value of SAR (measured) = 0.391 mW/g

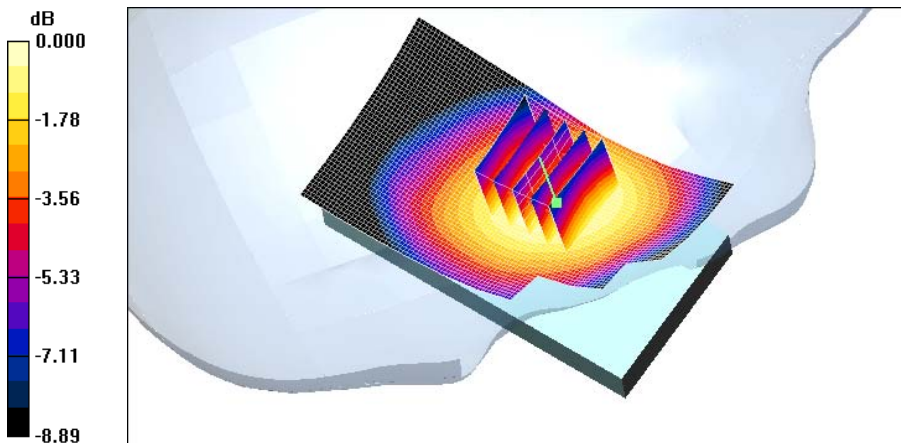

Test Laboratory: HCT CO., LTD
EUT Type: CDMA/LTE Phone with Bluetooth & WLAN
Liquid Temperature: 21.3 °C
Ambient Temperature: 21.5 °C
Test Date: Jun.08, 2011

DUT: ADR8995; Type: Bar; Serial: #1

Communication System: CDMA 835MHz FCC; Frequency: 836.52 MHz; Duty Cycle: 1:1
Medium parameters used (interpolated): $f = 836.52$ MHz; $\sigma = 0.889$ mho/m; $\epsilon_r = 41.4$; $\rho = 1000$ kg/m³
Phantom section: Right Section ; Measurement SW: DASY4, V4.7 Build 71; Postprocessing SW: SEMCAD, V1.8 Build 184

DASY4 Configuration:

- Probe: ES3DV3 - SN3161; ConvF(5.84, 5.84, 5.84); Calibrated: 2011-03-17
- Sensor-Surface: 4mm (Mechanical Surface Detection)
- Electronics: DAE3 Sn466; Calibrated: 2011-03-01
- Phantom: 835/900 Phantom ; Type: SAM

Right tilt 384/Area Scan (51x91x1): Measurement grid: dx=15mm, dy=15mm

[Info: Interpolated medium parameters used for SAR evaluation.](#)

MMaximum value of SAR (interpolated) = 0.262 mW/g

Right tilt 384/Zoom Scan (5x5x7)/Cube 0: Measurement grid: dx=8mm, dy=8mm, dz=5mm

Reference Value = 12.1 V/m; Power Drift = -0.005 dB

Peak SAR (extrapolated) = 0.311 W/kg

SAR(1 g) = 0.253 mW/g; SAR(10 g) = 0.195 mW/g

[Info: Interpolated medium parameters used for SAR evaluation.](#)

MMaximum value of SAR (measured) = 0.264 mW/g

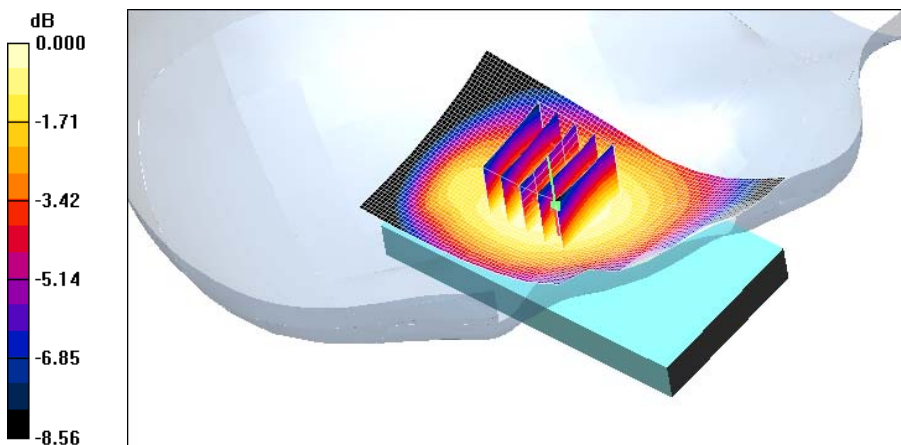

0 dB = 0.264mW/g

Test Laboratory: HCT CO., LTD
EUT Type: CDMA/LTE Phone with Bluetooth & WLAN
Liquid Temperature: 21.3 °C
Ambient Temperature: 21.5 °C
Test Date: Jun.08, 2011

DUT: ADR8995; Type: Bar; Serial: #1

Communication System: CDMA 835MHz FCC; Frequency: 836.52 MHz; Duty Cycle: 1:1
Medium parameters used (interpolated): $f = 836.52$ MHz; $\sigma = 0.889$ mho/m; $\epsilon_r = 41.4$; $\rho = 1000$ kg/m³
Phantom section: Left Section ; Measurement SW: DASY4, V4.7 Build 71; Postprocessing SW: SEMCAD, V1.8 Build 184

DASY4 Configuration:

- Probe: ES3DV3 - SN3161; ConvF(5.84, 5.84, 5.84); Calibrated: 2011-03-17
- Sensor-Surface: 4mm (Mechanical Surface Detection)
- Electronics: DAE3 Sn466; Calibrated: 2011-03-01
- Phantom: 800/900 Phantom; Type: SAM

Left touch 384/Area Scan (51x91x1): Measurement grid: dx=15mm, dy=15mm

[Info: Interpolated medium parameters used for SAR evaluation.](#)

MMaximum value of SAR (interpolated) = 0.691 mW/g

Left touch 384/Zoom Scan (5x5x7)/Cube 0: Measurement grid: dx=8mm, dy=8mm, dz=5mm

Reference Value = 24.4 V/m; Power Drift = -0.133 dB

Peak SAR (extrapolated) = 0.944 W/kg

SAR(1 g) = 0.598 mW/g; SAR(10 g) = 0.407 mW/g

[Info: Interpolated medium parameters used for SAR evaluation.](#)

Maximum value of SAR (measured) = 0.631 mW/g

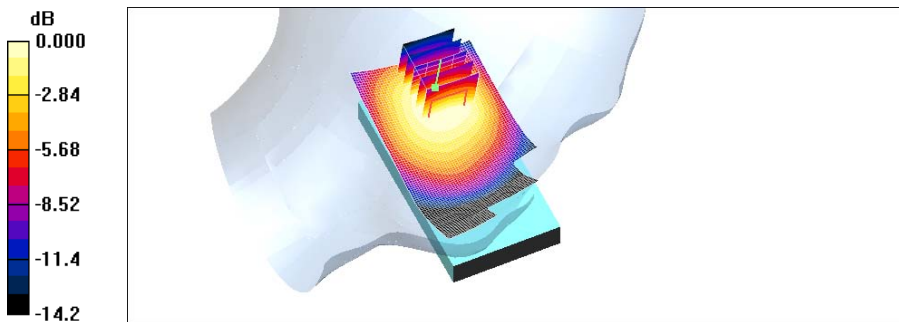

0 dB = 0.631mW/g

Test Laboratory: HCT CO., LTD
EUT Type: CDMA/LTE Phone with Bluetooth & WLAN
Liquid Temperature: 21.3 °C
Ambient Temperature: 21.5 °C
Test Date: Jun.08, 2011

DUT: ADR8995; Type: Bar; Serial: #1

Communication System: CDMA 835MHz FCC; Frequency: 836.52 MHz; Duty Cycle: 1:1
Medium parameters used (interpolated): $f = 836.52$ MHz; $\sigma = 0.889$ mho/m; $\epsilon_r = 41.4$; $\rho = 1000$ kg/m³
Phantom section: Left Section ; Measurement SW: DASY4, V4.7 Build 71; Postprocessing SW: SEMCAD, V1.8 Build 184

DASY4 Configuration:

- Probe: ES3DV3 - SN3161; ConvF(5.84, 5.84, 5.84); Calibrated: 2011-03-17
- Sensor-Surface: 4mm (Mechanical Surface Detection)
- Electronics: DAE3 Sn466; Calibrated: 2011-03-01
- Phantom: 800/900 Phantom; Type: SAM

Left tilt 384 EVDO/Area Scan (51x91x1): Measurement grid: dx=15mm, dy=15mm

[Info: Interpolated medium parameters used for SAR evaluation.](#)

MMaximum value of SAR (interpolated) = 0.606 mW/g

Left tilt 384 EVDO/Zoom Scan (5x5x7)/Cube 0: Measurement grid: dx=8mm, dy=8mm, dz=5mm

Reference Value = 22.5 V/m; Power Drift = 0.091 dB

Peak SAR (extrapolated) = 0.937 W/kg

SAR(1 g) = 0.497 mW/g; SAR(10 g) = 0.309 mW/g

[Info: Interpolated medium parameters used for SAR evaluation.](#)

Maximum value of SAR (measured) = 0.537 mW/g

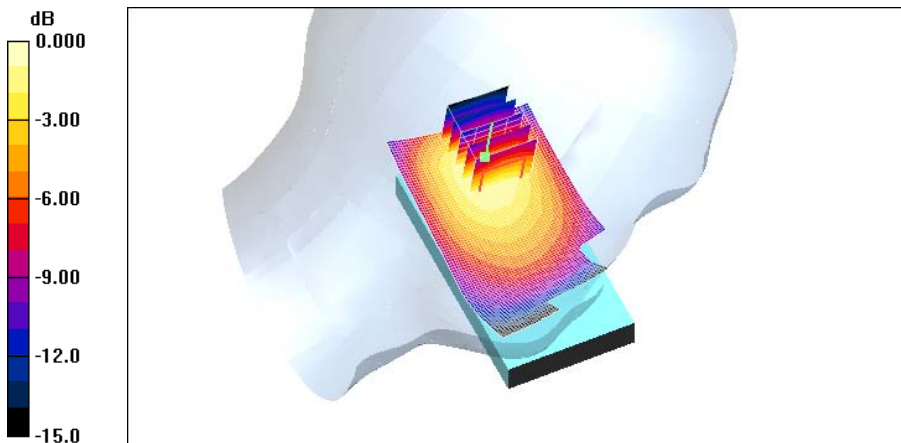

0 dB = 0.537mW/g

Test Laboratory: HCT CO., LTD
EUT Type: CDMA/LTE Phone with Bluetooth & WLAN
Liquid Temperature: 21.3 °C
Ambient Temperature: 21.5 °C
Test Date: Jun.08, 2011

DUT: ADR8995; Type: Bar; Serial: #1

Communication System: CDMA 835MHz FCC; Frequency: 836.52 MHz; Duty Cycle: 1:1
Medium parameters used (interpolated): $f = 836.52$ MHz; $\sigma = 0.889$ mho/m; $\epsilon_r = 41.4$; $\rho = 1000$ kg/m³
Phantom section: Right Section ; Measurement SW: DASY4, V4.7 Build 71; Postprocessing SW: SEMCAD, V1.8 Build 184

DASY4 Configuration:

- Probe: ES3DV3 - SN3161; ConvF(5.84, 5.84, 5.84); Calibrated: 2011-03-17
- Sensor-Surface: 4mm (Mechanical Surface Detection)
- Electronics: DAE3 Sn466; Calibrated: 2011-03-01
- Phantom: 800/900 Phantom; Type: SAM

Right touch EVDO 384/Area Scan (51x91x1): Measurement grid: dx=15mm, dy=15mm

[Info: Interpolated medium parameters used for SAR evaluation.](#)

MMaximum value of SAR (interpolated) = 0.512 mW/g

Right touch EVDO 384/Zoom Scan (5x5x7)/Cube 0: Measurement grid: dx=8mm, dy=8mm, dz=5mm

Reference Value = 21.8 V/m; Power Drift = -0.018 dB

Peak SAR (extrapolated) = 0.656 W/kg

SAR(1 g) = 0.480 mW/g; SAR(10 g) = 0.346 mW/g

[Info: Interpolated medium parameters used for SAR evaluation.](#)

MMaximum value of SAR (measured) = 0.508 mW/g

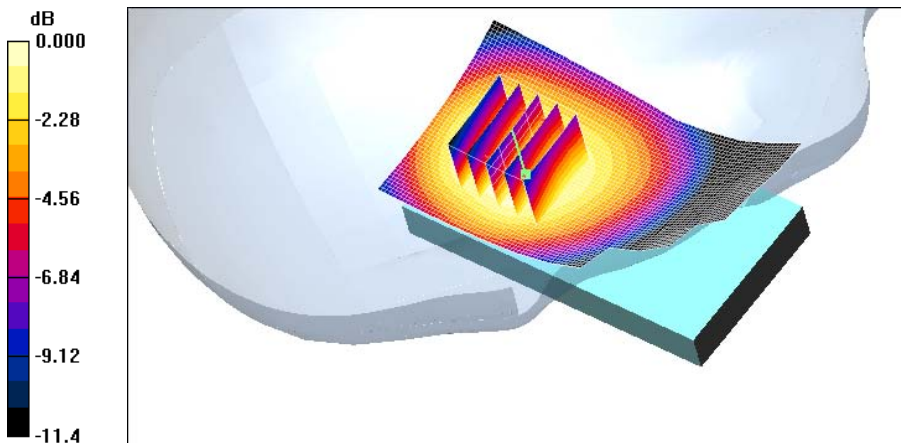

0 dB = 0.508mW/g

Test Laboratory: HCT CO., LTD
EUT Type: CDMA/LTE Phone with Bluetooth & WLAN
Liquid Temperature: 21.3 °C
Ambient Temperature: 21.5 °C
Test Date: Jun.08, 2011

DUT: ADR8995; Type: Bar; Serial: #1

Communication System: CDMA 835MHz FCC; Frequency: 836.52 MHz; Duty Cycle: 1:1
Medium parameters used (interpolated): $f = 836.52$ MHz; $\sigma = 0.889$ mho/m; $\epsilon_r = 41.4$; $\rho = 1000$ kg/m³
Phantom section: Right Section ; Measurement SW: DASY4, V4.7 Build 71; Postprocessing SW: SEMCAD, V1.8 Build 184

DASY4 Configuration:

- Probe: ES3DV3 - SN3161; ConvF(5.84, 5.84, 5.84); Calibrated: 2011-03-17
- Sensor-Surface: 4mm (Mechanical Surface Detection)
- Electronics: DAE3 Sn466; Calibrated: 2011-03-01
- Phantom: 800/900 Phantom; Type: SAM

Right tilt EVDO 384/Area Scan (51x91x1): Measurement grid: dx=15mm, dy=15mm

[Info: Interpolated medium parameters used for SAR evaluation.](#)

MMaximum value of SAR (interpolated) = 0.371 mW/g

Right tilt EVDO 384/Zoom Scan (5x5x7)/Cube 0: Measurement grid: dx=8mm, dy=8mm, dz=5mm

Reference Value = 19.7 V/m; Power Drift = 0.001 dB

Peak SAR (extrapolated) = 0.507 W/kg

SAR(1 g) = 0.342 mW/g; SAR(10 g) = 0.235 mW/g

[Info: Interpolated medium parameters used for SAR evaluation.](#)

Maximum value of SAR (measured) = 0.363 mW/g

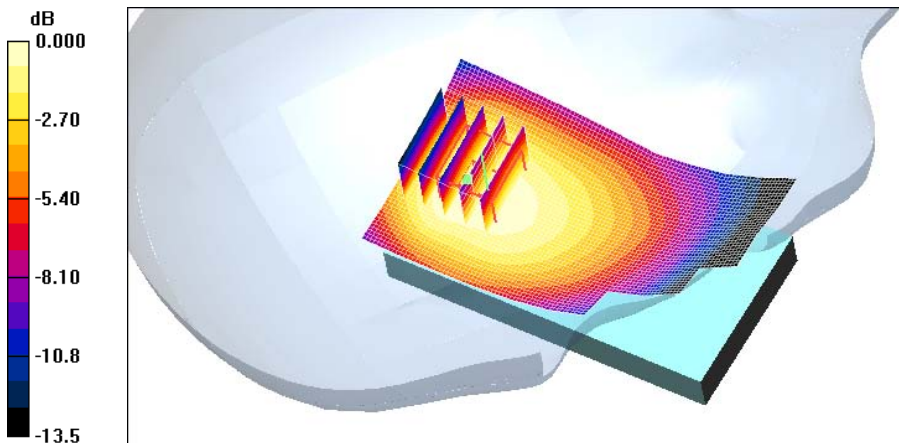

0 dB = 0.363mW/g

Test Laboratory: HCT CO., LTD
EUT Type: CDMA/LTE Phone with Bluetooth & WLAN
Liquid Temperature: 21.2 °C
Ambient Temperature: 21.4 °C
Test Date: Jun.09, 2011

DUT: ADR8995; Type: Bar; Serial: #1

Communication System: PCS 1900; Frequency: 1880 MHz; Duty Cycle: 1:1
Medium parameters used: $f = 1880$ MHz; $\sigma = 1.38$ mho/m; $\epsilon_r = 41.7$; $\rho = 1000$ kg/m³
Phantom section: Left Section ; Measurement SW: DASY4, V4.7 Build 71; Postprocessing SW: SEMCAD, V1.8 Build 184

DASY4 Configuration:

- Probe: ES3DV3 - SN3161; ConvF(4.91, 4.91, 4.91); Calibrated: 2011-03-17
- Sensor-Surface: 4mm (Mechanical Surface Detection)
- Electronics: DAE3 Sn466; Calibrated: 2011-03-01
- Phantom: 1800/1900 Phantom; Type: SAM

Left Touch 600/Area Scan (51x101x1): Measurement grid: dx=15mm, dy=15mm
MMaximum value of SAR (interpolated) = 0.404 mW/g

Left Touch 600/Zoom Scan (5x5x7)/Cube 0: Measurement grid: dx=8mm, dy=8mm, dz=5mm
Reference Value = 7.06 V/m; Power Drift = -0.192 dB
Peak SAR (extrapolated) = 0.567 W/kg
SAR(1 g) = 0.354 mW/g; SAR(10 g) = 0.216 mW/g
MMaximum value of SAR (measured) = 0.387 mW/g

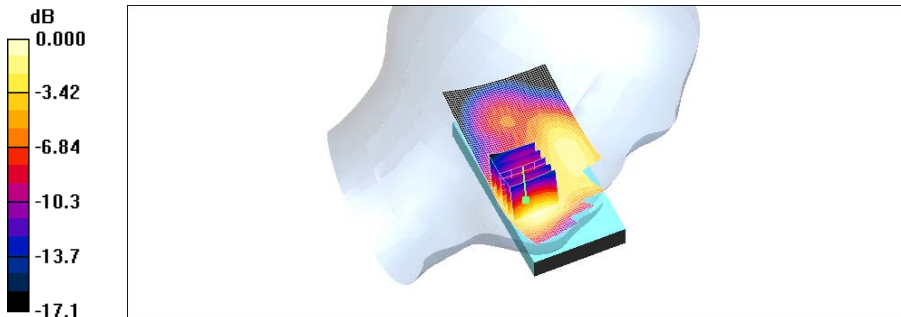

0 dB = 0.387mW/g

Test Laboratory: HCT CO., LTD
EUT Type: CDMA/LTE Phone with Bluetooth & WLAN
Liquid Temperature: 21.2 °C
Ambient Temperature: 21.4 °C
Test Date: Jun.09, 2011

DUT: ADR8995; Type: Bar; Serial: #1

Communication System: PCS 1900; Frequency: 1880 MHz; Duty Cycle: 1:1
Medium parameters used: $f = 1880$ MHz; $\sigma = 1.38$ mho/m; $\epsilon_r = 41.7$; $\rho = 1000$ kg/m³
Phantom section: Left Section ; Measurement SW: DASY4, V4.7 Build 71; Postprocessing SW: SEMCAD, V1.8 Build 184

DASY4 Configuration:

- Probe: ES3DV3 - SN3161; ConvF(4.91, 4.91, 4.91); Calibrated: 2011-03-17
- Sensor-Surface: 4mm (Mechanical Surface Detection)
- Electronics: DAE3 Sn466; Calibrated: 2011-03-01
- Phantom: 1800/1900 Phantom; Type: SAM

Left Tilt 600/Area Scan (51x101x1): Measurement grid: dx=15mm, dy=15mm
MMaximum value of SAR (interpolated) = 0.169 mW/g

Left Tilt 600/Zoom Scan (5x5x7)/Cube 0: Measurement grid: dx=8mm, dy=8mm, dz=5mm
Reference Value = 10.3 V/m; Power Drift = -0.004 dB
Peak SAR (extrapolated) = 0.251 W/kg
SAR(1 g) = 0.151 mW/g; SAR(10 g) = 0.089 mW/g
MMaximum value of SAR (measured) = 0.167 mW/g

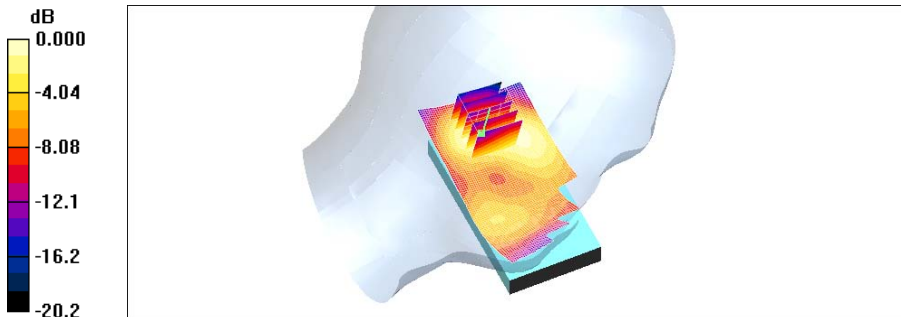

0 dB = 0.167mW/g

Test Laboratory: HCT CO., LTD
EUT Type: CDMA/LTE Phone with Bluetooth & WLAN
Liquid Temperature: 21.2 °C
Ambient Temperature: 21.4 °C
Test Date: Jun.09, 2011

DUT: ADR8995; Type: Bar; Serial: #1

Communication System: PCS 1900; Frequency: 1880 MHz; Duty Cycle: 1:1
Medium parameters used: $f = 1880$ MHz; $\sigma = 1.38$ mho/m; $\epsilon_r = 41.7$; $\rho = 1000$ kg/m³
Phantom section: Right Section ; Measurement SW: DASY4, V4.7 Build 71; Postprocessing SW: SEMCAD, V1.8 Build 184

DASY4 Configuration:

- Probe: ES3DV3 - SN3161; ConvF(4.91, 4.91, 4.91); Calibrated: 2011-03-17
- Sensor-Surface: 4mm (Mechanical Surface Detection)
- Electronics: DAE3 Sn466; Calibrated: 2011-03-01
- Phantom: 1800/1900 Phantom; Type: SAM

Right touch 600/Area Scan (51x101x1): Measurement grid: dx=15mm, dy=15mm
MMaximum value of SAR (interpolated) = 0.397 mW/g

Right touch 600/Zoom Scan (5x5x7)/Cube 0: Measurement grid: dx=8mm, dy=8mm, dz=5mm
Reference Value = 7.36 V/m; Power Drift = -0.013 dB
Peak SAR (extrapolated) = 0.568 W/kg
SAR(1 g) = 0.358 mW/g; SAR(10 g) = 0.218 mW/g
MMaximum value of SAR (measured) = 0.391 mW/g

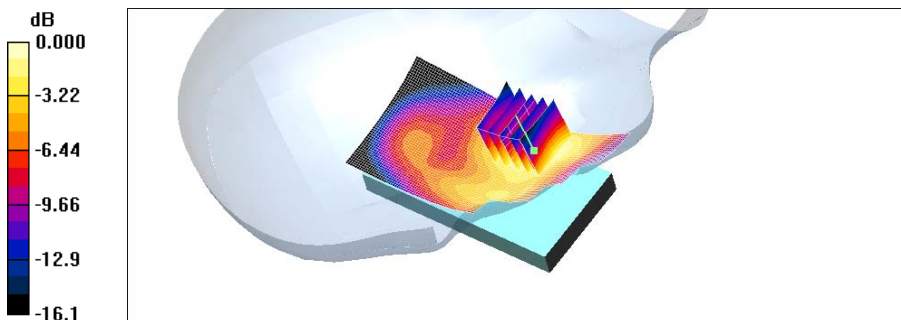

0 dB = 0.391mW/g

Test Laboratory: HCT CO., LTD
EUT Type: CDMA/LTE Phone with Bluetooth & WLAN
Liquid Temperature: 21.2 °C
Ambient Temperature: 21.4 °C
Test Date: Jun.09, 2011

DUT: ADR8995; Type: Bar; Serial: #1

Communication System: PCS 1900; Frequency: 1880 MHz; Duty Cycle: 1:1
Medium parameters used: $f = 1880$ MHz; $\sigma = 1.38$ mho/m; $\epsilon_r = 41.7$; $\rho = 1000$ kg/m³
Phantom section: Right Section ; Measurement SW: DASY4, V4.7 Build 71; Postprocessing SW: SEMCAD, V1.8 Build 184

DASY4 Configuration:

- Probe: ES3DV3 - SN3161; ConvF(4.91, 4.91, 4.91); Calibrated: 2011-03-17
- Sensor-Surface: 4mm (Mechanical Surface Detection)
- Electronics: DAE3 Sn466; Calibrated: 2011-03-01
- Phantom: 1800/1900 Phantom; Type: SAM

Right tilt 600/Area Scan (51x91x1): Measurement grid: dx=15mm, dy=15mm
MMaximum value of SAR (interpolated) = 0.197 mW/g

Right tilt 600/Zoom Scan (5x5x7)/Cube 0: Measurement grid: dx=8mm, dy=8mm, dz=5mm
Reference Value = 10.6 V/m; Power Drift = -0.020 dB
Peak SAR (extrapolated) = 0.301 W/kg
SAR(1 g) = 0.176 mW/g; SAR(10 g) = 0.098 mW/g
MMaximum value of SAR (measured) = 0.195 mW/g

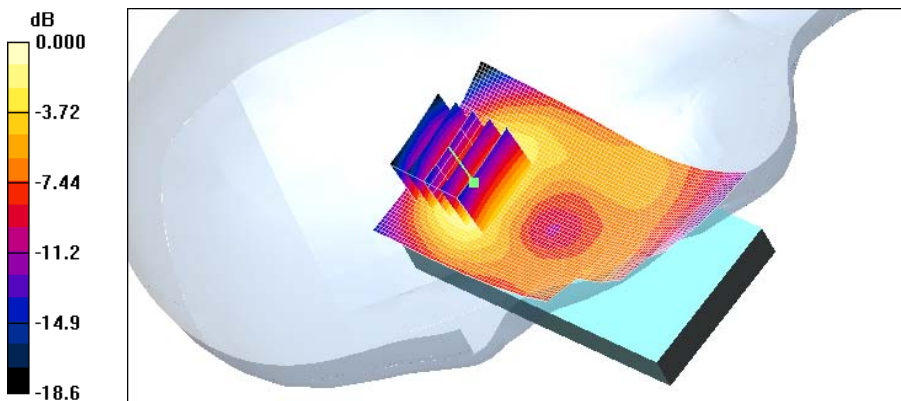

0 dB = 0.195mW/g

Test Laboratory: HCT CO., LTD
EUT Type: CDMA/LTE Phone with Bluetooth & WLAN
Liquid Temperature: 21.2 °C
Ambient Temperature: 21.4 °C
Test Date: Jun.09, 2011

DUT: ADR8995; Type: Bar; Serial: #1

Communication System: PCS 1900; Frequency: 1851.25 MHz; Duty Cycle: 1:1
Medium parameters used (interpolated): $f = 1851.25$ MHz; $\sigma = 1.35$ mho/m; $\epsilon_r = 41.8$; $\rho = 1000$ kg/m³
Phantom section: Left Section ; Measurement SW: DASY4, V4.7 Build 71; Postprocessing SW: SEMCAD, V1.8 Build 184

DASY4 Configuration:

- Probe: ES3DV3 - SN3161; ConvF(4.91, 4.91, 4.91); Calibrated: 2011-03-17
- Sensor-Surface: 4mm (Mechanical Surface Detection)
- Electronics: DAE3 Sn466; Calibrated: 2011-03-01
- Phantom: 1800/1900 Phantom; Type: SAM

Left Touch EVDO 25/Area Scan (51x91x1): Measurement grid: dx=15mm, dy=15mm

[Info: Interpolated medium parameters used for SAR evaluation.](#)

MMaximum value of SAR (interpolated) = 0.869 mW/g

Left Touch EVDO 25/Zoom Scan (5x5x7)/Cube 0: Measurement grid: dx=8mm, dy=8mm, dz=5mm

Reference Value = 22.1 V/m; Power Drift = 0.081 dB

Peak SAR (extrapolated) = 1.80 W/kg

SAR(1 g) = 0.844 mW/g; SAR(10 g) = 0.410 mW/g

[Info: Interpolated medium parameters used for SAR evaluation.](#)

MMaximum value of SAR (measured) = 0.900 mW/g

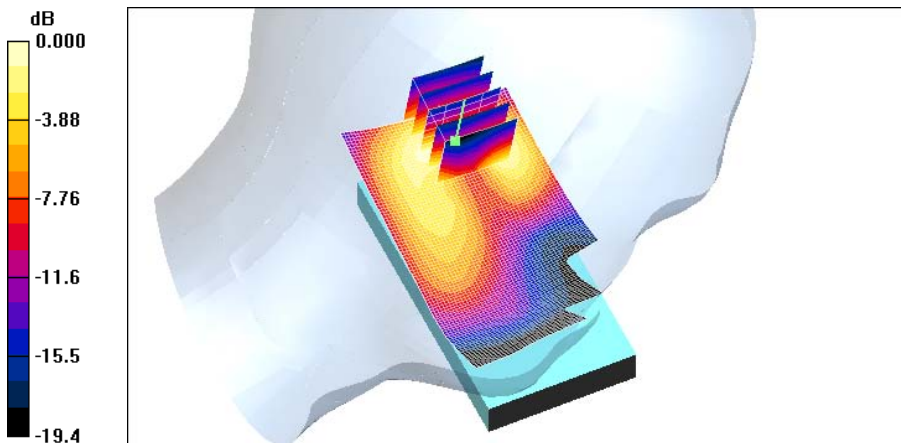

0 dB = 0.900mW/g

Test Laboratory: HCT CO., LTD
EUT Type: CDMA/LTE Phone with Bluetooth & WLAN
Liquid Temperature: 21.2 °C
Ambient Temperature: 21.4 °C
Test Date: Jun.09, 2011

DUT: ADR8995; Type: Bar; Serial: #1

Communication System: PCS 1900; Frequency: 1880 MHz; Duty Cycle: 1:1
Medium parameters used: $f = 1880$ MHz; $\sigma = 1.38$ mho/m; $\epsilon_r = 41.7$; $\rho = 1000$ kg/m³
Phantom section: Left Section ; Measurement SW: DASY4, V4.7 Build 71; Postprocessing SW: SEMCAD, V1.8 Build 184

DASY4 Configuration:

- Probe: ES3DV3 - SN3161; ConvF(4.91, 4.91, 4.91); Calibrated: 2011-03-17
- Sensor-Surface: 4mm (Mechanical Surface Detection)
- Electronics: DAE3 Sn466; Calibrated: 2011-03-01
- Phantom: 1800/1900 Phantom; Type: SAM

Left Touch EVDO 600/Area Scan (51x91x1): Measurement grid: dx=15mm, dy=15mm
MMaximum value of SAR (interpolated) = 1.01 mW/g

Left Touch EVDO 600/Zoom Scan (5x5x7)/Cube 0: Measurement grid: dx=8mm, dy=8mm, dz=5mm
Reference Value = 20.3 V/m; Power Drift = -0.145 dB
Peak SAR (extrapolated) = 1.83 W/kg
SAR(1 g) = 0.885 mW/g; SAR(10 g) = 0.435 mW/g
MMaximum value of SAR (measured) = 1.01 mW/g

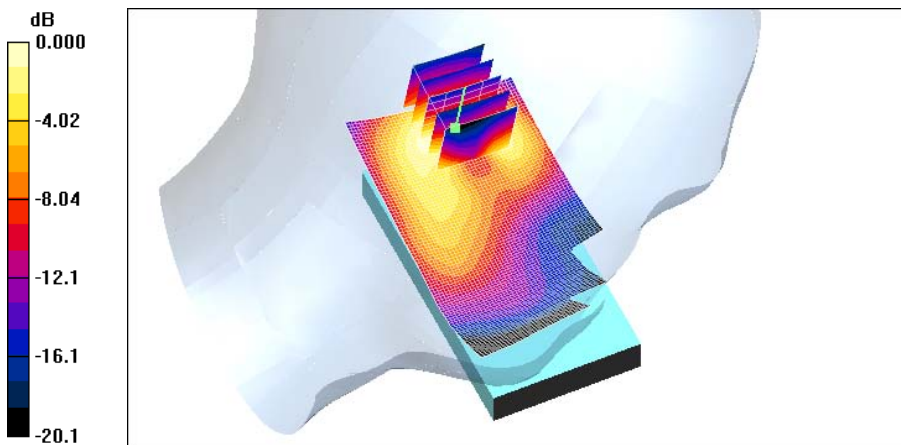

0 dB = 1.01mW/g

Test Laboratory: HCT CO., LTD
EUT Type: CDMA/LTE Phone with Bluetooth & WLAN
Liquid Temperature: 21.2 °C
Ambient Temperature: 21.4 °C
Test Date: Jun.09, 2011

DUT: ADR8995; Type: Bar; Serial: #1

Communication System: PCS 1900; Frequency: 1908.75 MHz; Duty Cycle: 1:1
Medium parameters used (interpolated): $f = 1908.75$ MHz; $\sigma = 1.41$ mho/m; $\epsilon_r = 41.5$; $\rho = 1000$ kg/m³
Phantom section: Left Section ; Measurement SW: DASY4, V4.7 Build 71; Postprocessing SW: SEMCAD, V1.8 Build 184

DASY4 Configuration:

- Probe: ES3DV3 - SN3161; ConvF(4.91, 4.91, 4.91); Calibrated: 2011-03-17
- Sensor-Surface: 4mm (Mechanical Surface Detection)
- Electronics: DAE3 Sn466; Calibrated: 2011-03-01
- Phantom: 1800/1900 Phantom; Type: SAM

Left Touch EVDO 1175/Area Scan (51x91x1): Measurement grid: dx=15mm, dy=15mm

[Info: Interpolated medium parameters used for SAR evaluation.](#)

MMaximum value of SAR (interpolated) = 1.06 mW/g

Left Touch EVDO 1175/Zoom Scan (5x5x7)/Cube 0: Measurement grid: dx=8mm, dy=8mm, dz=5mm

Reference Value = 22.3 V/m; Power Drift = 0.087 dB

Peak SAR (extrapolated) = 1.99 W/kg

SAR(1 g) = 0.927 mW/g; SAR(10 g) = 0.447 mW/g

[Info: Interpolated medium parameters used for SAR evaluation.](#)

MMaximum value of SAR (measured) = 1.05 mW/g

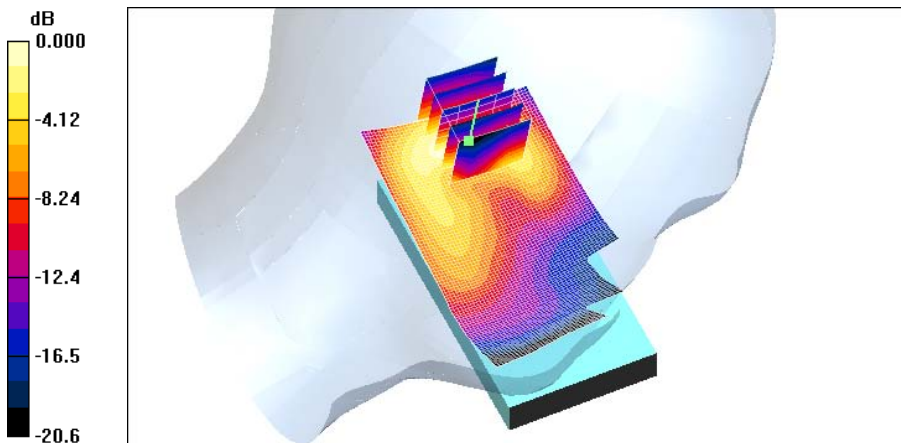

0 dB = 1.05mW/g

Test Laboratory: HCT CO., LTD
EUT Type: CDMA/LTE Phone with Bluetooth & WLAN
Liquid Temperature: 21.2 °C
Ambient Temperature: 21.4 °C
Test Date: Jun.09, 2011

DUT: ADR8995; Type: Bar; Serial: #1

Communication System: PCS 1900; Frequency: 1851.25 MHz; Duty Cycle: 1:1
Medium parameters used (interpolated): $f = 1851.25$ MHz; $\sigma = 1.35$ mho/m; $\epsilon_r = 41.8$; $\rho = 1000$ kg/m³
Phantom section: Left Section ; Measurement SW: DASY4, V4.7 Build 71; Postprocessing SW: SEMCAD, V1.8 Build 184

DASY4 Configuration:

- Probe: ES3DV3 - SN3161; ConvF(4.91, 4.91, 4.91); Calibrated: 2011-03-17
- Sensor-Surface: 4mm (Mechanical Surface Detection)
- Electronics: DAE3 Sn466; Calibrated: 2011-03-01
- Phantom: 1800/1900 Phantom; Type: SAM

Left Tilt EVDO 25/Area Scan (51x91x1): Measurement grid: dx=15mm, dy=15mm

[Info: Interpolated medium parameters used for SAR evaluation.](#)

MMaximum value of SAR (interpolated) = 0.968 mW/g

Left Tilt EVDO 25/Zoom Scan (5x5x7)/Cube 0: Measurement grid: dx=8mm, dy=8mm, dz=5mm

Reference Value = 22.1 V/m; Power Drift = 0.105 dB

Peak SAR (extrapolated) = 1.66 W/kg

SAR(1 g) = 0.856 mW/g; SAR(10 g) = 0.434 mW/g

[Info: Interpolated medium parameters used for SAR evaluation.](#)

MMaximum value of SAR (measured) = 0.962 mW/g

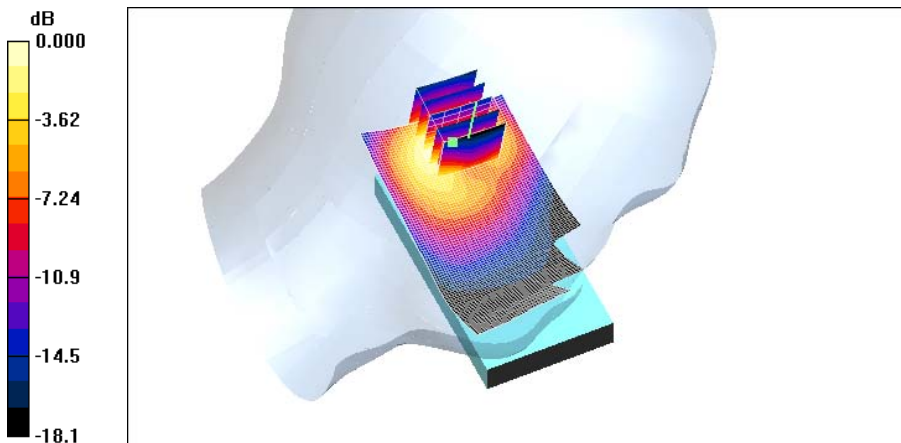

0 dB = 0.962mW/g

Test Laboratory: HCT CO., LTD
EUT Type: CDMA/LTE Phone with Bluetooth & WLAN
Liquid Temperature: 21.2 °C
Ambient Temperature: 21.4 °C
Test Date: Jun.09, 2011

DUT: ADR8995; Type: Bar; Serial: #1

Communication System: PCS 1900; Frequency: 1880 MHz; Duty Cycle: 1:1
Medium parameters used: $f = 1880$ MHz; $\sigma = 1.38$ mho/m; $\epsilon_r = 41.7$; $\rho = 1000$ kg/m³
Phantom section: Left Section ; Measurement SW: DASY4, V4.7 Build 71; Postprocessing SW: SEMCAD, V1.8 Build 184

DASY4 Configuration:

- Probe: ES3DV3 - SN3161; ConvF(4.91, 4.91, 4.91); Calibrated: 2011-03-17
- Sensor-Surface: 4mm (Mechanical Surface Detection)
- Electronics: DAE3 Sn466; Calibrated: 2011-03-01
- Phantom: 1800/1900 Phantom; Type: SAM

Left Tilt EVDO 600/Area Scan (51x91x1): Measurement grid: dx=15mm, dy=15mm
MMaximum value of SAR (interpolated) = 1.20 mW/g

Left Tilt EVDO 600/Zoom Scan (5x5x7)/Cube 0: Measurement grid: dx=8mm, dy=8mm, dz=5mm
Reference Value = 24.1 V/m; Power Drift = 0.009 dB
Peak SAR (extrapolated) = 2.05 W/kg
SAR(1 g) = 1.05 mW/g; SAR(10 g) = 0.523 mW/g
MMaximum value of SAR (measured) = 1.16 mW/g

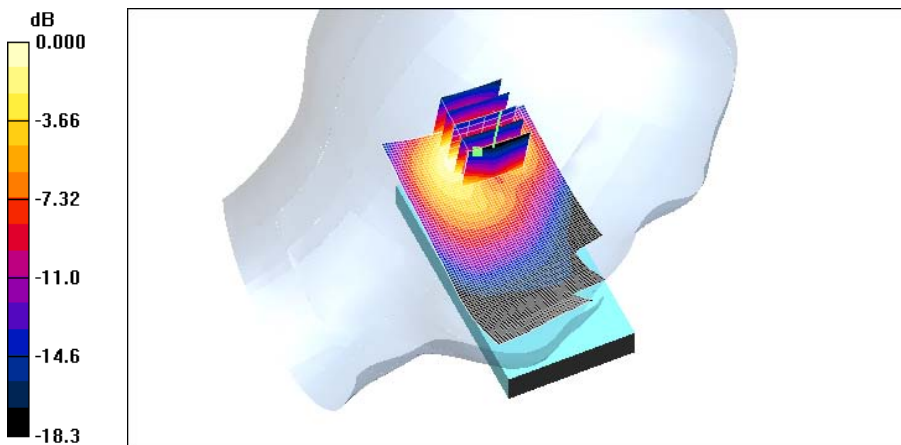

0 dB = 1.16mW/g

Test Laboratory: HCT CO., LTD
EUT Type: CDMA/LTE Phone with Bluetooth & WLAN
Liquid Temperature: 21.2 °C
Ambient Temperature: 21.4 °C
Test Date: Jun.09, 2011

DUT: ADR8995; Type: Bar; Serial: #1

Communication System: PCS 1900; Frequency: 1908.75 MHz; Duty Cycle: 1:1
Medium parameters used (interpolated): $f = 1908.75$ MHz; $\sigma = 1.41$ mho/m; $\epsilon_r = 41.5$; $\rho = 1000$ kg/m³
Phantom section: Left Section ; Measurement SW: DASY4, V4.7 Build 71; Postprocessing SW: SEMCAD, V1.8 Build 184

DASY4 Configuration:

- Probe: ES3DV3 - SN3161; ConvF(4.91, 4.91, 4.91); Calibrated: 2011-03-17
- Sensor-Surface: 4mm (Mechanical Surface Detection)
- Electronics: DAE3 Sn466; Calibrated: 2011-03-01
- Phantom: 1800/1900 Phantom; Type: SAM

Left Tilt EVDO 1175/Area Scan (51x91x1): Measurement grid: dx=15mm, dy=15mm

[Info: Interpolated medium parameters used for SAR evaluation.](#)

MMaximum value of SAR (interpolated) = 1.03 mW/g

Left Tilt EVDO 1175/Zoom Scan (5x5x7)/Cube 0: Measurement grid: dx=8mm, dy=8mm, dz=5mm

Reference Value = 21.6 V/m; Power Drift = 0.127 dB

Peak SAR (extrapolated) = 1.81 W/kg

SAR(1 g) = 0.910 mW/g; SAR(10 g) = 0.450 mW/g

[Info: Interpolated medium parameters used for SAR evaluation.](#)

MMaximum value of SAR (measured) = 1.04 mW/g

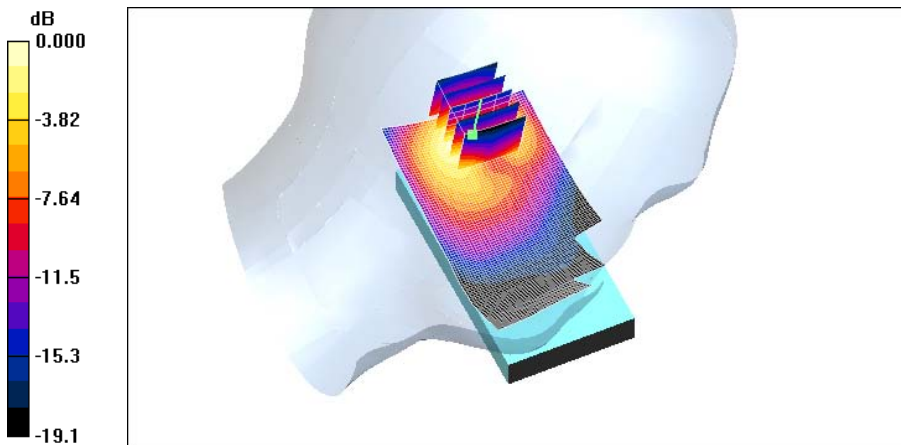

0 dB = 1.04mW/g

Test Laboratory: HCT CO., LTD
EUT Type: CDMA/LTE Phone with Bluetooth & WLAN
Liquid Temperature: 21.2 °C
Ambient Temperature: 21.4 °C
Test Date: Jun.09, 2011

DUT: ADR8995; Type: Bar; Serial: #1

Communication System: PCS 1900; Frequency: 1880 MHz; Duty Cycle: 1:1
Medium parameters used: $f = 1880$ MHz; $\sigma = 1.38$ mho/m; $\epsilon_r = 41.7$; $\rho = 1000$ kg/m³
Phantom section: Right Section ; Measurement SW: DASY4, V4.7 Build 71; Postprocessing SW: SEMCAD, V1.8 Build 184

DASY4 Configuration:

- Probe: ES3DV3 - SN3161; ConvF(4.91, 4.91, 4.91); Calibrated: 2011-03-17
- Sensor-Surface: 4mm (Mechanical Surface Detection)
- Electronics: DAE3 Sn466; Calibrated: 2011-03-01
- Phantom: 1800/1900 Phantom; Type: SAM

Right touch EVDO 600/Area Scan (51x91x1): Measurement grid: dx=15mm, dy=15mm
MMaximum value of SAR (interpolated) = 0.702 mW/g

Right touch EVDO 600/Zoom Scan (5x5x7)/Cube 0: Measurement grid: dx=8mm, dy=8mm, dz=5mm
Reference Value = 18.7 V/m; Power Drift = 0.02 dB
Peak SAR (extrapolated) = 1.24 W/kg
SAR(1 g) = 0.665 mW/g; SAR(10 g) = 0.355 mW/g
MMaximum value of SAR (measured) = 0.714 mW/g

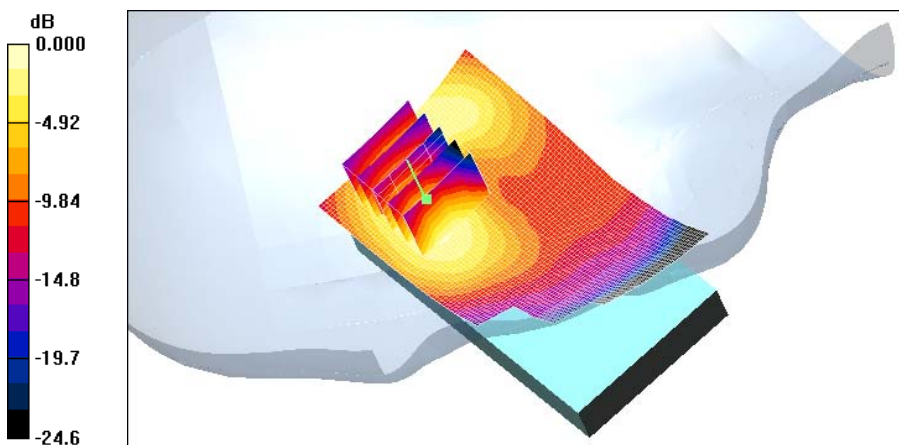

0 dB = 0.714mW/g

Test Laboratory: HCT CO., LTD
EUT Type: CDMA/LTE Phone with Bluetooth & WLAN
Liquid Temperature: 21.2 °C
Ambient Temperature: 21.4 °C
Test Date: Jun.09, 2011

DUT: ADR8995; Type: Bar; Serial: #1

Communication System: PCS 1900; Frequency: 1880 MHz; Duty Cycle: 1:1
Medium parameters used: $f = 1880$ MHz; $\sigma = 1.38$ mho/m; $\epsilon_r = 41.7$; $\rho = 1000$ kg/m³
Phantom section: Right Section ; Measurement SW: DASY4, V4.7 Build 71; Postprocessing SW: SEMCAD, V1.8 Build 184

DASY4 Configuration:

- Probe: ES3DV3 - SN3161; ConvF(4.91, 4.91, 4.91); Calibrated: 2011-03-17
- Sensor-Surface: 4mm (Mechanical Surface Detection)
- Electronics: DAE3 Sn466; Calibrated: 2011-03-01
- Phantom: 1800/1900 Phantom; Type: SAM

Right tilt EVDO 600/Area Scan (51x91x1): Measurement grid: dx=15mm, dy=15mm
MMaximum value of SAR (interpolated) = 0.786 mW/g

Right tilt EVDO 600/Zoom Scan (5x5x7)/Cube 0: Measurement grid: dx=8mm, dy=8mm, dz=5mm
Reference Value = 22.9 V/m; Power Drift = 0.014 dB
Peak SAR (extrapolated) = 1.41 W/kg
SAR(1 g) = 0.765 mW/g; SAR(10 g) = 0.403 mW/g
Maximum value of SAR (measured) = 0.846 mW/g

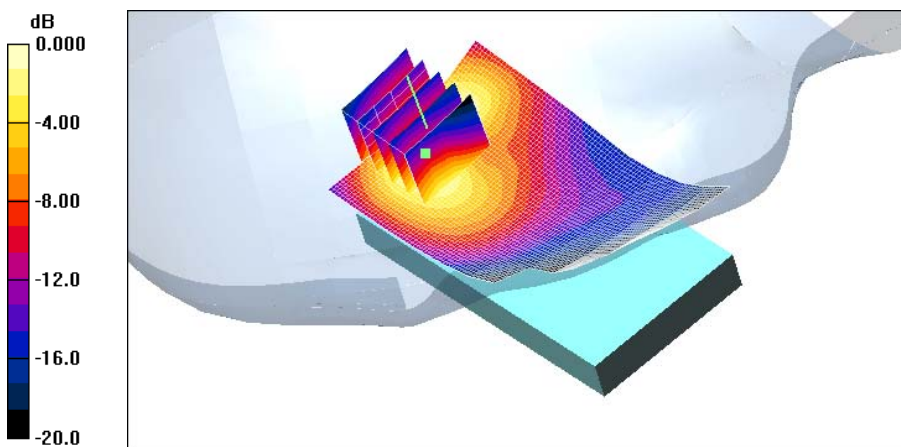

0 dB = 0.846mW/g

Test Laboratory: HCT CO., LTD
EUT Type: CDMA/LTE Phone with Bluetooth & WLAN
Liquid Temperature: 21.2 °C
Ambient Temperature: 21.4 °C
Test Date: May.06, 2011

DUT: ADR8995; Type: Bar; Serial: #1

Communication System: LTE; Frequency: 782 MHz; Duty Cycle: 1:1
Medium parameters used: $f = 782.5$ MHz; $\sigma = 0.893$ mho/m; $\epsilon_r = 41.7$; $\rho = 1000$ kg/m³
Phantom section: Left Section ; Measurement SW: DASY4, V4.7 Build 71; Postprocessing SW: SEMCAD, V1.8 Build 184

DASY4 Configuration:

- Probe: ES3DV3 - SN3161; ConvF(6.1, 6.1, 6.1); Calibrated: 2011-03-17
- Sensor-Surface: 4mm (Mechanical Surface Detection)
- Electronics: DAE3 Sn466; Calibrated: 2011-03-01
- Phantom: 835/900 Phantom ; Type: SAM

Left Touch 23230 QPSK 1 0/Area Scan (51x91x1): Measurement grid: dx=15mm, dy=15mm
MMaximum value of SAR (interpolated) = 0.304 mW/g

Left Touch 23230 QPSK 1 0/Zoom Scan (5x5x7)/Cube 0: Measurement grid: dx=8mm, dy=8mm, dz=5mm
Reference Value = 17.3 V/m; Power Drift = -0.069 dB
Peak SAR (extrapolated) = 0.393 W/kg
SAR(1 g) = 0.271 mW/g; SAR(10 g) = 0.191 mW/g
Maximum value of SAR (measured) = 0.286 mW/g

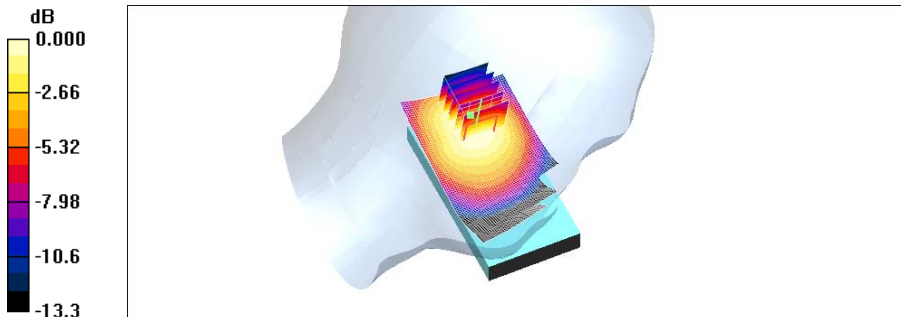

0 dB = 0.286mW/g

Test Laboratory: HCT CO., LTD
EUT Type: CDMA/LTE Phone with Bluetooth & WLAN
Liquid Temperature: 21.2 °C
Ambient Temperature: 21.4 °C
Test Date: May.06, 2011

DUT: ADR8995; Type: Bar; Serial: #1

Communication System: LTE; Frequency: 782 MHz; Duty Cycle: 1:1
Medium parameters used: $f = 782.5$ MHz; $\sigma = 0.893$ mho/m; $\epsilon_r = 41.7$; $\rho = 1000$ kg/m³
Phantom section: Left Section ; Measurement SW: DASY4, V4.7 Build 71; Postprocessing SW: SEMCAD, V1.8 Build 184

DASY4 Configuration:

- Probe: ES3DV3 - SN3161; ConvF(6.1, 6.1, 6.1); Calibrated: 2011-03-17
- Sensor-Surface: 4mm (Mechanical Surface Detection)
- Electronics: DAE3 Sn466; Calibrated: 2011-03-01
- Phantom: 835/900 Phantom ; Type: SAM

Left Tilt 23230 QPSK 1 0/Area Scan (51x91x1): Measurement grid: dx=15mm, dy=15mm
MMaximum value of SAR (interpolated) = 0.281 mW/g

Left Tilt 23230 QPSK 1 0/Zoom Scan (5x5x7)/Cube 0: Measurement grid: dx=8mm, dy=8mm, dz=5mm
Reference Value = 16.2 V/m; Power Drift = 0.052 dB
Peak SAR (extrapolated) = 0.438 W/kg
SAR(1 g) = 0.243 mW/g; SAR(10 g) = 0.158 mW/g
Maximum value of SAR (measured) = 0.269 mW/g

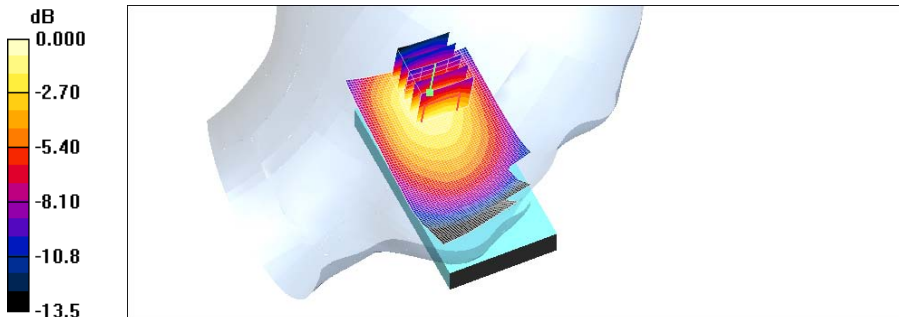

0 dB = 0.269mW/g

Test Laboratory: HCT CO., LTD
EUT Type: CDMA/LTE Phone with Bluetooth & WLAN
Liquid Temperature: 21.2 °C
Ambient Temperature: 21.4 °C
Test Date: May.06, 2011

DUT: ADR8995; Type: Bar; Serial: #1

Communication System: LTE; Frequency: 782 MHz; Duty Cycle: 1:1
Medium parameters used: $f = 782.5$ MHz; $\sigma = 0.893$ mho/m; $\epsilon_r = 41.7$; $\rho = 1000$ kg/m³
Phantom section: Left Section ; Measurement SW: DASY4, V4.7 Build 71; Postprocessing SW: SEMCAD, V1.8 Build 184

DASY4 Configuration:

- Probe: ES3DV3 - SN3161; ConvF(6.1, 6.1, 6.1); Calibrated: 2011-03-17
- Sensor-Surface: 4mm (Mechanical Surface Detection)
- Electronics: DAE3 Sn466; Calibrated: 2011-03-01
- Phantom: 835/900 Phantom ; Type: SAM

Left Touch 23230 QPSK 1 49/Area Scan (51x91x1): Measurement grid: dx=15mm, dy=15mm
MMaximum value of SAR (interpolated) = 0.373 mW/g

Left Touch 23230 QPSK 1 49/Zoom Scan (5x5x7)/Cube 0: Measurement grid: dx=8mm, dy=8mm, dz=5mm
Reference Value = 18.7 V/m; Power Drift = 0.080 dB
Peak SAR (extrapolated) = 0.495 W/kg
SAR(1 g) = 0.321 mW/g; SAR(10 g) = 0.225 mW/g
Maximum value of SAR (measured) = 0.336 mW/g

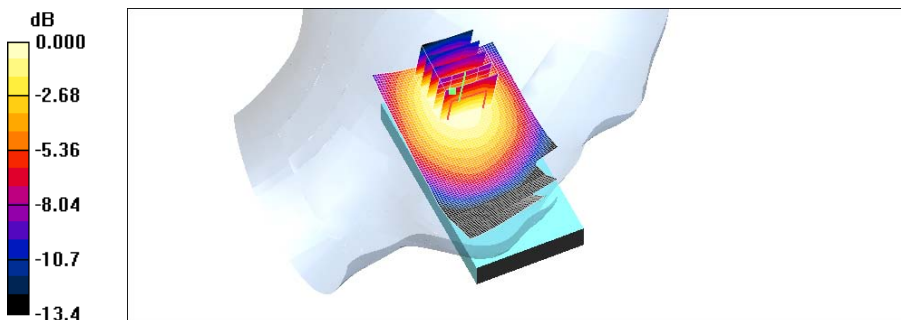

0 dB = 0.336mW/g

Test Laboratory: HCT CO., LTD
EUT Type: CDMA/LTE Phone with Bluetooth & WLAN
Liquid Temperature: 21.2 °C
Ambient Temperature: 21.4 °C
Test Date: May.06, 2011

DUT: ADR8995; Type: Bar; Serial: #1

Communication System: LTE; Frequency: 782 MHz; Duty Cycle: 1:1
Medium parameters used: $f = 782.5$ MHz; $\sigma = 0.893$ mho/m; $\epsilon_r = 41.7$; $\rho = 1000$ kg/m³
Phantom section: Left Section ; Measurement SW: DASY4, V4.7 Build 71; Postprocessing SW: SEMCAD, V1.8 Build 184

DASY4 Configuration:

- Probe: ES3DV3 - SN3161; ConvF(6.1, 6.1, 6.1); Calibrated: 2011-03-17
- Sensor-Surface: 4mm (Mechanical Surface Detection)
- Electronics: DAE3 Sn466; Calibrated: 2011-03-01
- Phantom: 835/900 Phantom ; Type: SAM

Left Tilt 23230 QPSK 1 49/Area Scan (51x91x1): Measurement grid: dx=15mm, dy=15mm
MMaximum value of SAR (interpolated) = 0.323 mW/g

Left Tilt 23230 QPSK 1 49/Zoom Scan (5x5x7)/Cube 0: Measurement grid: dx=8mm, dy=8mm, dz=5mm
Reference Value = 17.7 V/m; Power Drift = -0.065 dB
Peak SAR (extrapolated) = 0.483 W/kg
SAR(1 g) = 0.280 mW/g; SAR(10 g) = 0.183 mW/g
MMaximum value of SAR (measured) = 0.301 mW/g

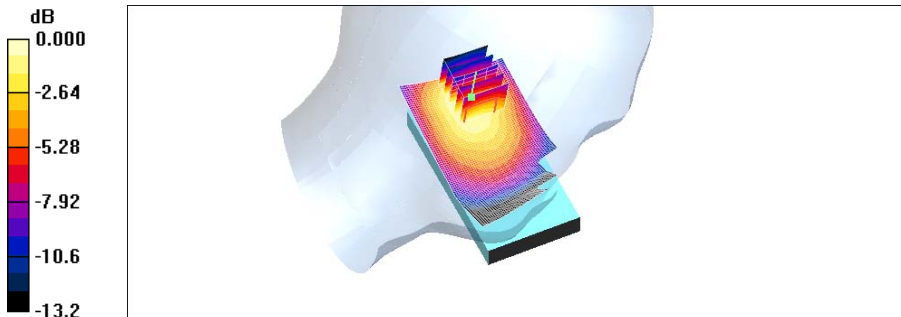

0 dB = 0.301mW/g

Test Laboratory: HCT CO., LTD
EUT Type: CDMA/LTE Phone with Bluetooth & WLAN
Liquid Temperature: 21.2 °C
Ambient Temperature: 21.4 °C
Test Date: May.06, 2011

DUT: ADR8995; Type: Bar; Serial: #1

Communication System: LTE; Frequency: 782 MHz; Duty Cycle: 1:1
Medium parameters used: $f = 782.5$ MHz; $\sigma = 0.893$ mho/m; $\epsilon_r = 41.7$; $\rho = 1000$ kg/m³
Phantom section: Left Section ; Measurement SW: DASY4, V4.7 Build 71; Postprocessing SW: SEMCAD, V1.8 Build 184

DASY4 Configuration:

- Probe: ES3DV3 - SN3161; ConvF(6.1, 6.1, 6.1); Calibrated: 2011-03-17
- Sensor-Surface: 4mm (Mechanical Surface Detection)
- Electronics: DAE3 Sn466; Calibrated: 2011-03-01
- Phantom: 835/900 Phantom ; Type: SAM

Left Touch 23230 QPSK 25 13/Area Scan (51x91x1): Measurement grid: dx=15mm, dy=15mm
MMaximum value of SAR (interpolated) = 0.257 mW/g

Left Touch 23230 QPSK 25 13/Zoom Scan (5x5x7)/Cube 0: Measurement grid: dx=8mm, dy=8mm, dz=5mm
Reference Value = 15.8 V/m; Power Drift = -0.109 dB
Peak SAR (extrapolated) = 0.344 W/kg
SAR(1 g) = 0.229 mW/g; SAR(10 g) = 0.161 mW/g
Maximum value of SAR (measured) = 0.240 mW/g

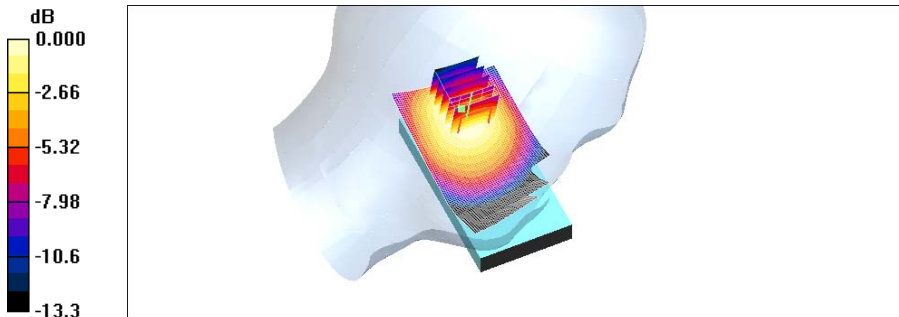

0 dB = 0.240mW/g

Test Laboratory: HCT CO., LTD
EUT Type: CDMA/LTE Phone with Bluetooth & WLAN
Liquid Temperature: 21.2 °C
Ambient Temperature: 21.4 °C
Test Date: May.06, 2011

DUT: ADR8995; Type: Bar; Serial: #1

Communication System: LTE; Frequency: 782 MHz; Duty Cycle: 1:1
Medium parameters used: $f = 782.5$ MHz; $\sigma = 0.893$ mho/m; $\epsilon_r = 41.7$; $\rho = 1000$ kg/m³
Phantom section: Left Section ; Measurement SW: DASY4, V4.7 Build 71; Postprocessing SW: SEMCAD, V1.8 Build 184

DASY4 Configuration:

- Probe: ES3DV3 - SN3161; ConvF(6.1, 6.1, 6.1); Calibrated: 2011-03-17
- Sensor-Surface: 4mm (Mechanical Surface Detection)
- Electronics: DAE3 Sn466; Calibrated: 2011-03-01
- Phantom: 835/900 Phantom ; Type: SAM

Left Tilt 23230 QPSK 25 13/Area Scan (51x91x1): Measurement grid: dx=15mm, dy=15mm
MMaximum value of SAR (interpolated) = 0.228 mW/g

Left Tilt 23230 QPSK 25 13/Zoom Scan (5x5x7)/Cube 0: Measurement grid: dx=8mm, dy=8mm, dz=5mm
Reference Value = 14.8 V/m; Power Drift = -0.02 dB
Peak SAR (extrapolated) = 0.332 W/kg
SAR(1 g) = 0.193 mW/g; SAR(10 g) = 0.128 mW/g
Maximum value of SAR (measured) = 0.207 mW/g

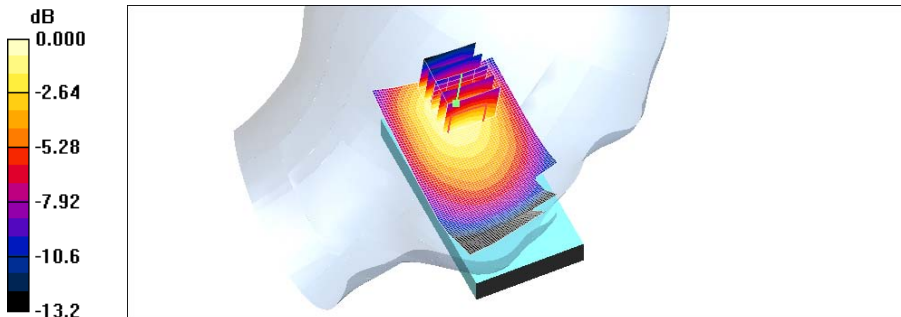

0 dB = 0.207mW/g

Test Laboratory: HCT CO., LTD
EUT Type: CDMA/LTE Phone with Bluetooth & WLAN
Liquid Temperature: 21.2 °C
Ambient Temperature: 21.4 °C
Test Date: May.06, 2011

DUT: ADR8995; Type: Bar; Serial: #1

Communication System: LTE; Frequency: 782 MHz; Duty Cycle: 1:1
Medium parameters used: $f = 782.5$ MHz; $\sigma = 0.893$ mho/m; $\epsilon_r = 41.7$; $\rho = 1000$ kg/m³
Phantom section: Right Section ; Measurement SW: DASY4, V4.7 Build 71; Postprocessing SW: SEMCAD, V1.8 Build 184

DASY4 Configuration:

- Probe: ES3DV3 - SN3161; ConvF(6.1, 6.1, 6.1); Calibrated: 2011-03-17
- Sensor-Surface: 4mm (Mechanical Surface Detection)
- Electronics: DAE3 Sn466; Calibrated: 2011-03-01
- Phantom: 835/900 Phantom ; Type: SAM

Right Touch 23230 QPSK 1 0/Area Scan (51x91x1): Measurement grid: dx=15mm, dy=15mm
MMaximum value of SAR (interpolated) = 0.233 mW/g

Right Touch 23230 QPSK 1 0/Zoom Scan (5x5x7)/Cube 0: Measurement grid: dx=8mm, dy=8mm, dz=5mm
Reference Value = 16.0 V/m; Power Drift = 0.047 dB
Peak SAR (extrapolated) = 0.322 W/kg
SAR(1 g) = 0.221 mW/g; SAR(10 g) = 0.157 mW/g
Maximum value of SAR (measured) = 0.239 mW/g

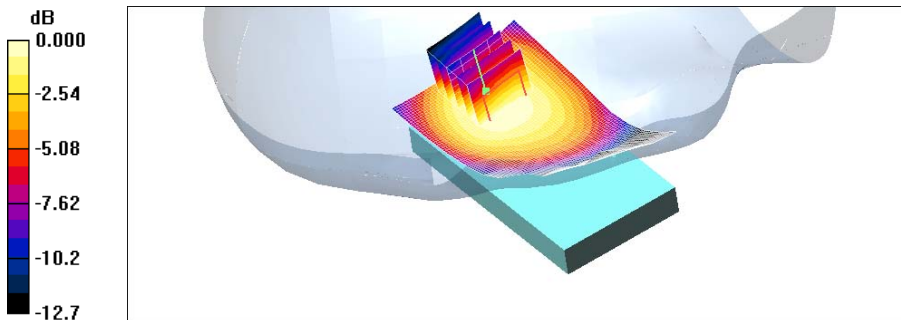

0 dB = 0.239mW/g

Test Laboratory: HCT CO., LTD
EUT Type: CDMA/LTE Phone with Bluetooth & WLAN
Liquid Temperature: 21.2 °C
Ambient Temperature: 21.4 °C
Test Date: May.06, 2011

DUT: ADR8995; Type: Bar; Serial: #1

Communication System: LTE; Frequency: 782 MHz; Duty Cycle: 1:1
Medium parameters used: $f = 782.5$ MHz; $\sigma = 0.893$ mho/m; $\epsilon_r = 41.7$; $\rho = 1000$ kg/m³
Phantom section: Right Section ; Measurement SW: DASY4, V4.7 Build 71; Postprocessing SW: SEMCAD, V1.8 Build 184

DASY4 Configuration:

- Probe: ES3DV3 - SN3161; ConvF(6.1, 6.1, 6.1); Calibrated: 2011-03-17
- Sensor-Surface: 4mm (Mechanical Surface Detection)
- Electronics: DAE3 Sn466; Calibrated: 2011-03-01
- Phantom: 835/900 Phantom ; Type: SAM

Right Tilt 23230 QPSK 1 0/Area Scan (51x91x1): Measurement grid: dx=15mm, dy=15mm
MMaximum value of SAR (interpolated) = 0.204 mW/g

Right Tilt 23230 QPSK 1 0/Zoom Scan (5x5x7)/Cube 0: Measurement grid: dx=8mm, dy=8mm, dz=5mm
Reference Value = 15.0 V/m; Power Drift = 0.067 dB
Peak SAR (extrapolated) = 0.284 W/kg
SAR(1 g) = 0.190 mW/g; SAR(10 g) = 0.132 mW/g
Maximum value of SAR (measured) = 0.203 mW/g

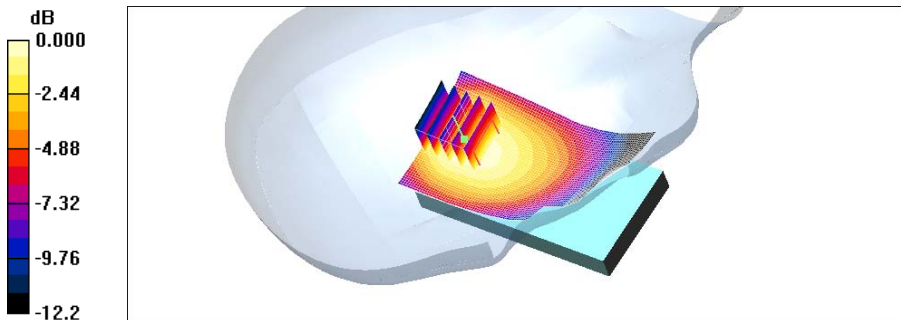

0 dB = 0.203mW/g

Test Laboratory: HCT CO., LTD
EUT Type: CDMA/LTE Phone with Bluetooth & WLAN
Liquid Temperature: 21.2 °C
Ambient Temperature: 21.4 °C
Test Date: May.06, 2011

DUT: ADR8995; Type: Bar; Serial: #1

Communication System: LTE; Frequency: 782 MHz; Duty Cycle: 1:1
Medium parameters used: $f = 782.5$ MHz; $\sigma = 0.893$ mho/m; $\epsilon_r = 41.7$; $\rho = 1000$ kg/m³
Phantom section: Right Section ; Measurement SW: DASY4, V4.7 Build 71; Postprocessing SW: SEMCAD, V1.8 Build 184

DASY4 Configuration:

- Probe: ES3DV3 - SN3161; ConvF(6.1, 6.1, 6.1); Calibrated: 2011-03-17
- Sensor-Surface: 4mm (Mechanical Surface Detection)
- Electronics: DAE3 Sn466; Calibrated: 2011-03-01
- Phantom: 835/900 Phantom ; Type: SAM

Right Touch 23230 QPSK 1 49/Area Scan (51x91x1): Measurement grid: dx=15mm, dy=15mm
MMaximum value of SAR (interpolated) = 0.281 mW/g

Right Touch 23230 QPSK 1 49/Zoom Scan (5x5x7)/Cube 0: Measurement grid: dx=8mm, dy=8mm, dz=5mm
Reference Value = 17.4 V/m; Power Drift = 0.002 dB
Peak SAR (extrapolated) = 0.395 W/kg
SAR(1 g) = 0.265 mW/g; SAR(10 g) = 0.186 mW/g
Maximum value of SAR (measured) = 0.281 mW/g

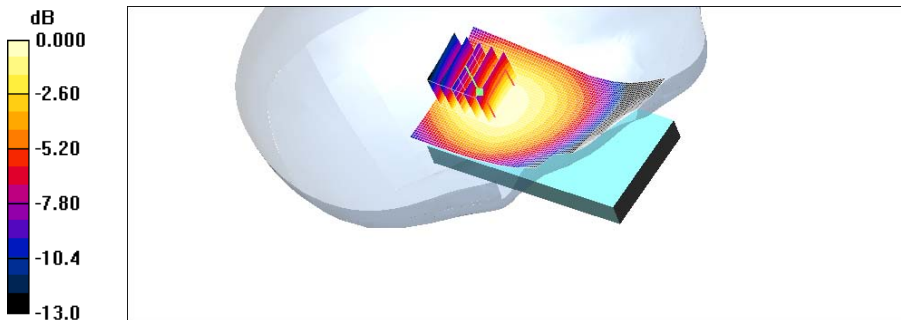

0 dB = 0.281mW/g

Test Laboratory: HCT CO., LTD
EUT Type: CDMA/LTE Phone with Bluetooth & WLAN
Liquid Temperature: 21.2 °C
Ambient Temperature: 21.4 °C
Test Date: May.06, 2011

DUT: ADR8995; Type: Bar; Serial: #1

Communication System: LTE; Frequency: 782 MHz; Duty Cycle: 1:1
Medium parameters used: $f = 782.5$ MHz; $\sigma = 0.893$ mho/m; $\epsilon_r = 41.7$; $\rho = 1000$ kg/m³
Phantom section: Right Section ; Measurement SW: DASY4, V4.7 Build 71; Postprocessing SW: SEMCAD, V1.8 Build 184

DASY4 Configuration:

- Probe: ES3DV3 - SN3161; ConvF(6.1, 6.1, 6.1); Calibrated: 2011-03-17
- Sensor-Surface: 4mm (Mechanical Surface Detection)
- Electronics: DAE3 Sn466; Calibrated: 2011-03-01
- Phantom: 835/900 Phantom ; Type: SAM

Right Tilt 23230 QPSK 1 49/Area Scan (51x91x1): Measurement grid: dx=15mm, dy=15mm
MMaximum value of SAR (interpolated) = 0.238 mW/g

Right Tilt 23230 QPSK 1 49/Zoom Scan (5x5x7)/Cube 0: Measurement grid: dx=8mm, dy=8mm, dz=5mm
Reference Value = 16.1 V/m; Power Drift = 0.002 dB
Peak SAR (extrapolated) = 0.328 W/kg
SAR(1 g) = 0.219 mW/g; SAR(10 g) = 0.151 mW/g
Maximum value of SAR (measured) = 0.233 mW/g

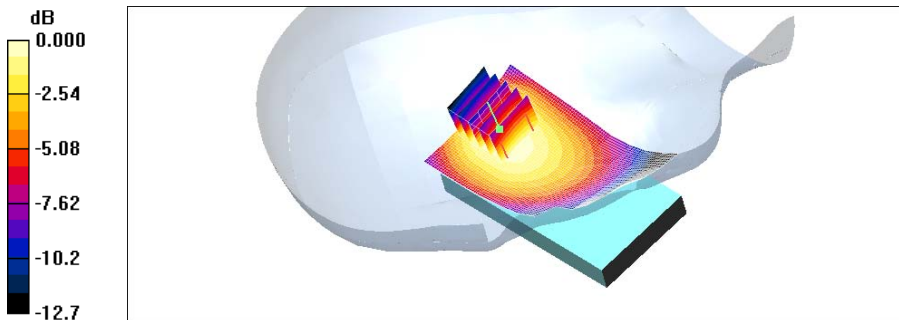

0 dB = 0.233mW/g

Test Laboratory: HCT CO., LTD
EUT Type: CDMA/LTE Phone with Bluetooth & WLAN
Liquid Temperature: 21.2 °C
Ambient Temperature: 21.4 °C
Test Date: May.06, 2011

DUT: ADR8995; Type: Bar; Serial: #1

Communication System: LTE; Frequency: 782 MHz; Duty Cycle: 1:1
Medium parameters used: $f = 782.5$ MHz; $\sigma = 0.893$ mho/m; $\epsilon_r = 41.7$; $\rho = 1000$ kg/m³
Phantom section: Right Section ; Measurement SW: DASY4, V4.7 Build 71; Postprocessing SW: SEMCAD, V1.8 Build 184

DASY4 Configuration:

- Probe: ES3DV3 - SN3161; ConvF(6.1, 6.1, 6.1); Calibrated: 2011-03-17
- Sensor-Surface: 4mm (Mechanical Surface Detection)
- Electronics: DAE3 Sn466; Calibrated: 2011-03-01
- Phantom: 835/900 Phantom ; Type: SAM

Right Touch 23230 QPSK 25 13/Area Scan (51x91x1): Measurement grid: dx=15mm, dy=15mm
MMaximum value of SAR (interpolated) = 0.201 mW/g

Right Touch 23230 QPSK 25 13/Zoom Scan (5x5x7)/Cube 0: Measurement grid: dx=8mm, dy=8mm, dz=5mm
Reference Value = 14.7 V/m; Power Drift = -0.004 dB
Peak SAR (extrapolated) = 0.280 W/kg
SAR(1 g) = 0.189 mW/g; SAR(10 g) = 0.133 mW/g
Maximum value of SAR (measured) = 0.200 mW/g

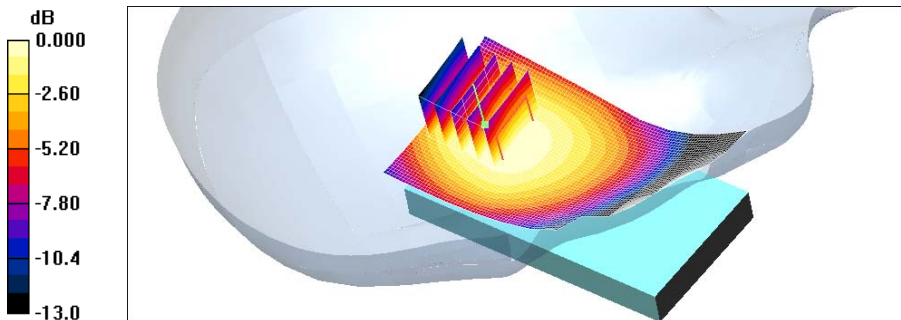

0 dB = 0.200mW/g

Test Laboratory: HCT CO., LTD
EUT Type: CDMA/LTE Phone with Bluetooth & WLAN
Liquid Temperature: 21.2 °C
Ambient Temperature: 21.4 °C
Test Date: May.06, 2011

DUT: ADR8995; Type: Bar; Serial: #1

Communication System: LTE; Frequency: 782 MHz; Duty Cycle: 1:1
Medium parameters used: $f = 782.5$ MHz; $\sigma = 0.893$ mho/m; $\epsilon_r = 41.7$; $\rho = 1000$ kg/m³
Phantom section: Right Section ; Measurement SW: DASY4, V4.7 Build 71; Postprocessing SW: SEMCAD, V1.8 Build 184

DASY4 Configuration:

- Probe: ES3DV3 - SN3161; ConvF(6.1, 6.1, 6.1); Calibrated: 2011-03-17
- Sensor-Surface: 4mm (Mechanical Surface Detection)
- Electronics: DAE3 Sn466; Calibrated: 2011-03-01
- Phantom: 835/900 Phantom ; Type: SAM

Right Tilt 23230 QPSK 25 13/Area Scan (51x91x1): Measurement grid: dx=15mm, dy=15mm
MMaximum value of SAR (interpolated) = 0.161 mW/g

Right Tilt 23230 QPSK 25 13/Zoom Scan (5x5x7)/Cube 0: Measurement grid: dx=8mm, dy=8mm, dz=5mm
Reference Value = 13.4 V/m; Power Drift = -0.124 dB
Peak SAR (extrapolated) = 0.224 W/kg
SAR(1 g) = 0.150 mW/g; SAR(10 g) = 0.104 mW/g
Maximum value of SAR (measured) = 0.159 mW/g

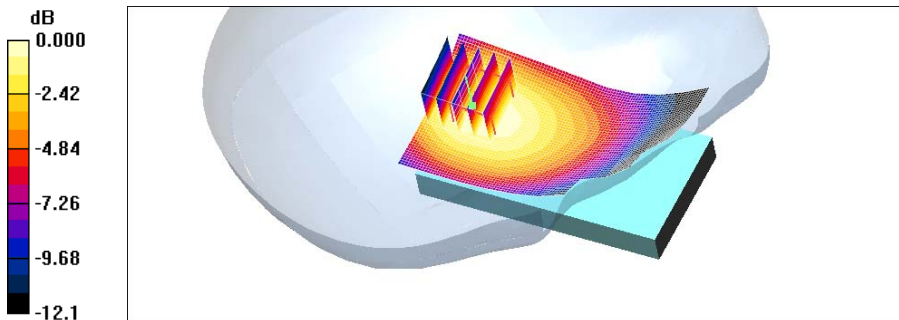

0 dB = 0.159mW/g

Test Laboratory: HCT CO., LTD
EUT Type: CDMA/LTE Phone with Bluetooth & WLAN
Liquid Temperature: 21.2 °C
Ambient Temperature: 21.4 °C
Test Date: May.06, 2011

DUT: ADR8995; Type: Bar; Serial: #1

Communication System: LTE; Frequency: 782 MHz; Duty Cycle: 1:1
Medium parameters used: $f = 782.5$ MHz; $\sigma = 0.893$ mho/m; $\epsilon_r = 41.7$; $\rho = 1000$ kg/m³
Phantom section: Left Section ; Measurement SW: DASY4, V4.7 Build 71; Postprocessing SW: SEMCAD, V1.8 Build 184

DASY4 Configuration:

- Probe: ES3DV3 - SN3161; ConvF(6.1, 6.1, 6.1); Calibrated: 2011-03-17
- Sensor-Surface: 4mm (Mechanical Surface Detection)
- Electronics: DAE3 Sn466; Calibrated: 2011-03-01
- Phantom: 835/900 Phantom ; Type: SAM

Left Touch 23230 16QAM 1 0/Area Scan (51x91x1): Measurement grid: dx=15mm, dy=15mm
MMaximum value of SAR (interpolated) = 0.239 mW/g

Left Touch 23230 16QAM 1 0/Zoom Scan (5x5x7)/Cube 0: Measurement grid: dx=8mm, dy=8mm, dz=5mm
Reference Value = 15.1 V/m; Power Drift = 0.018 dB
Peak SAR (extrapolated) = 0.302 W/kg
SAR(1 g) = 0.209 mW/g; SAR(10 g) = 0.148 mW/g
Maximum value of SAR (measured) = 0.220 mW/g

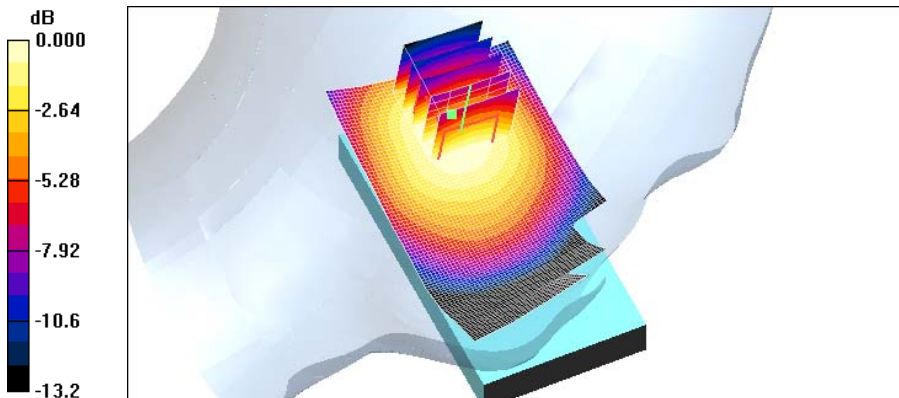

0 dB = 0.220mW/g

Test Laboratory: HCT CO., LTD
EUT Type: CDMA/LTE Phone with Bluetooth & WLAN
Liquid Temperature: 21.2 °C
Ambient Temperature: 21.4 °C
Test Date: May.06, 2011

DUT: ADR8995; Type: Bar; Serial: #1

Communication System: LTE; Frequency: 782 MHz; Duty Cycle: 1:1
Medium parameters used: $f = 782.5$ MHz; $\sigma = 0.893$ mho/m; $\epsilon_r = 41.7$; $\rho = 1000$ kg/m³
Phantom section: Left Section ; Measurement SW: DASY4, V4.7 Build 71; Postprocessing SW: SEMCAD, V1.8 Build 184

DASY4 Configuration:

- Probe: ES3DV3 - SN3161; ConvF(6.1, 6.1, 6.1); Calibrated: 2011-03-17
- Sensor-Surface: 4mm (Mechanical Surface Detection)
- Electronics: DAE3 Sn466; Calibrated: 2011-03-01
- Phantom: 835/900 Phantom ; Type: SAM

Left Tilt 23230 16QAM 1 0/Area Scan (51x91x1): Measurement grid: dx=15mm, dy=15mm
MMaximum value of SAR (interpolated) = 0.219 mW/g

Left Tilt 23230 16QAM 1 0/Zoom Scan (5x5x7)/Cube 0: Measurement grid: dx=8mm, dy=8mm, dz=5mm
Reference Value = 14.2 V/m; Power Drift = 0.052 dB
Peak SAR (extrapolated) = 0.303 W/kg
SAR(1 g) = 0.184 mW/g; SAR(10 g) = 0.123 mW/g
Maximum value of SAR (measured) = 0.196 mW/g

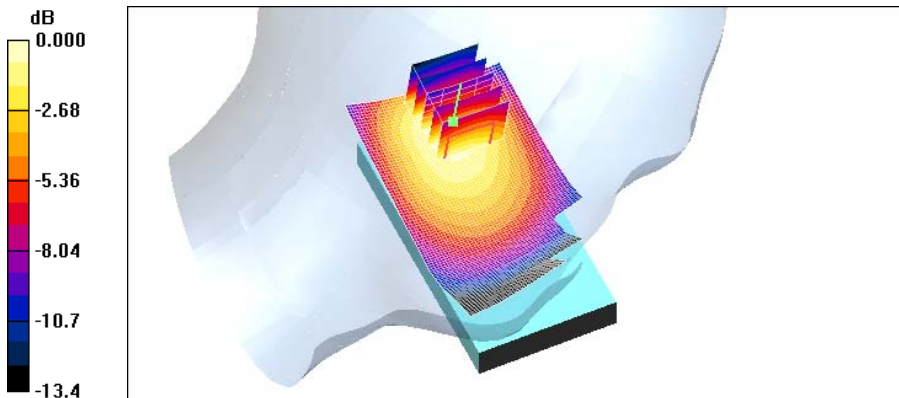

0 dB = 0.196mW/g

Test Laboratory: HCT CO., LTD
EUT Type: CDMA/LTE Phone with Bluetooth & WLAN
Liquid Temperature: 21.2 °C
Ambient Temperature: 21.4 °C
Test Date: May.06, 2011

DUT: ADR8995; Type: Bar; Serial: #1

Communication System: LTE; Frequency: 782 MHz; Duty Cycle: 1:1
Medium parameters used: $f = 782.5$ MHz; $\sigma = 0.893$ mho/m; $\epsilon_r = 41.7$; $\rho = 1000$ kg/m³
Phantom section: Left Section ; Measurement SW: DASY4, V4.7 Build 71; Postprocessing SW: SEMCAD, V1.8 Build 184

DASY4 Configuration:

- Probe: ES3DV3 - SN3161; ConvF(6.1, 6.1, 6.1); Calibrated: 2011-03-17
- Sensor-Surface: 4mm (Mechanical Surface Detection)
- Electronics: DAE3 Sn466; Calibrated: 2011-03-01
- Phantom: 835/900 Phantom ; Type: SAM

Left Touch 23230 16QAM 1 49/Area Scan (51x91x1): Measurement grid: dx=15mm, dy=15mm
MMaximum value of SAR (interpolated) = 0.299 mW/g

Left Touch 23230 16QAM 1 49/Zoom Scan (5x5x7)/Cube 0: Measurement grid: dx=8mm, dy=8mm, dz=5mm
Reference Value = 16.9 V/m; Power Drift = 0.111 dB
Peak SAR (extrapolated) = 0.381 W/kg
SAR(1 g) = 0.264 mW/g; SAR(10 g) = 0.187 mW/g
Maximum value of SAR (measured) = 0.277 mW/g

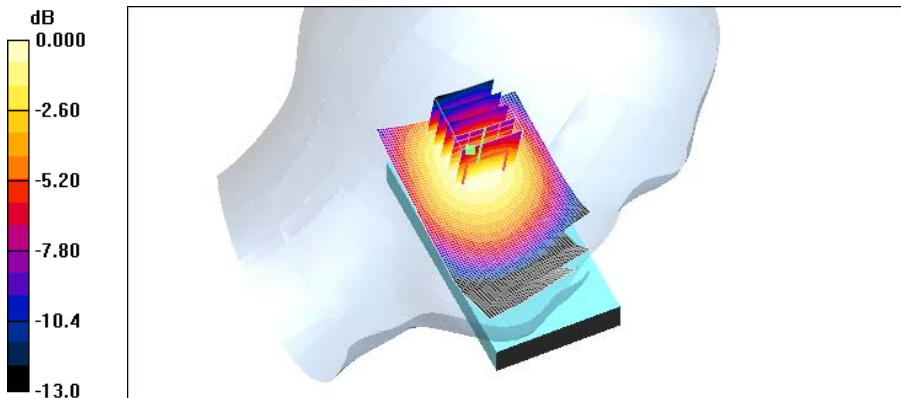

0 dB = 0.277mW/g

Test Laboratory: HCT CO., LTD
EUT Type: CDMA/LTE Phone with Bluetooth & WLAN
Liquid Temperature: 21.2 °C
Ambient Temperature: 21.4 °C
Test Date: May.06, 2011

DUT: ADR8995; Type: Bar; Serial: #1

Communication System: LTE; Frequency: 782 MHz; Duty Cycle: 1:1
Medium parameters used: $f = 782.5$ MHz; $\sigma = 0.893$ mho/m; $\epsilon_r = 41.7$; $\rho = 1000$ kg/m³
Phantom section: Left Section ; Measurement SW: DASY4, V4.7 Build 71; Postprocessing SW: SEMCAD, V1.8 Build 184

DASY4 Configuration:

- Probe: ES3DV3 - SN3161; ConvF(6.1, 6.1, 6.1); Calibrated: 2011-03-17
- Sensor-Surface: 4mm (Mechanical Surface Detection)
- Electronics: DAE3 Sn466; Calibrated: 2011-03-01
- Phantom: 835/900 Phantom ; Type: SAM

Left Tilt 230 16QAM 1 49/Area Scan (51x91x1): Measurement grid: dx=15mm, dy=15mm
MMaximum value of SAR (interpolated) = 0.266 mW/g

Left Tilt 230 16QAM 1 49/Zoom Scan (5x5x7)/Cube 0: Measurement grid: dx=8mm, dy=8mm, dz=5mm
Reference Value = 15.8 V/m; Power Drift = 0.049 dB
Peak SAR (extrapolated) = 0.404 W/kg
SAR(1 g) = 0.227 mW/g; SAR(10 g) = 0.150 mW/g
MMaximum value of SAR (measured) = 0.239 mW/g

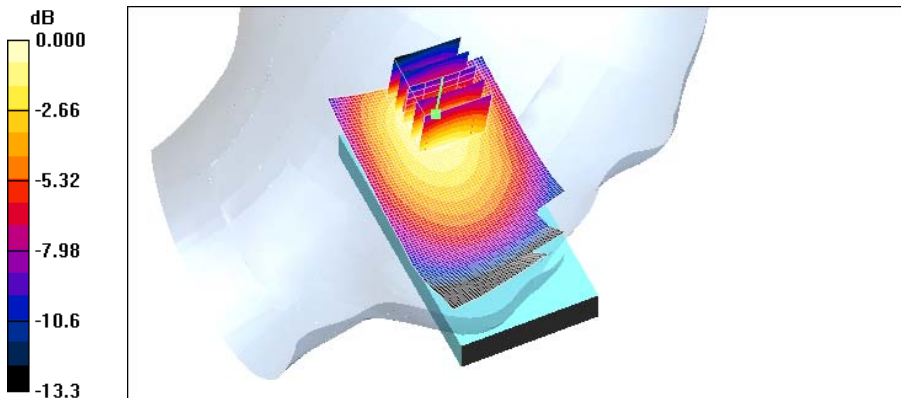

0 dB = 0.239mW/g

Test Laboratory: HCT CO., LTD
EUT Type: CDMA/LTE Phone with Bluetooth & WLAN
Liquid Temperature: 21.2 °C
Ambient Temperature: 21.4 °C
Test Date: May.06, 2011

DUT: ADR8995; Type: Bar; Serial: #1

Communication System: LTE; Frequency: 782 MHz; Duty Cycle: 1:1
Medium parameters used: $f = 782.5$ MHz; $\sigma = 0.893$ mho/m; $\epsilon_r = 41.7$; $\rho = 1000$ kg/m³
Phantom section: Left Section ; Measurement SW: DASY4, V4.7 Build 71; Postprocessing SW: SEMCAD, V1.8 Build 184

DASY4 Configuration:

- Probe: ES3DV3 - SN3161; ConvF(6.1, 6.1, 6.1); Calibrated: 2011-03-17
- Sensor-Surface: 4mm (Mechanical Surface Detection)
- Electronics: DAE3 Sn466; Calibrated: 2011-03-01
- Phantom: 835/900 Phantom ; Type: SAM

Left Touch 23230 16QAM 25 13/Area Scan (51x91x1): Measurement grid: dx=15mm, dy=15mm
MMaximum value of SAR (interpolated) = 0.219 mW/g

Left Touch 23230 16QAM 25 13/Zoom Scan (5x5x7)/Cube 0: Measurement grid: dx=8mm, dy=8mm, dz=5mm
Reference Value = 14.2 V/m; Power Drift = 0.084 dB
Peak SAR (extrapolated) = 0.282 W/kg
SAR(1 g) = 0.194 mW/g; SAR(10 g) = 0.136 mW/g
Maximum value of SAR (measured) = 0.204 mW/g

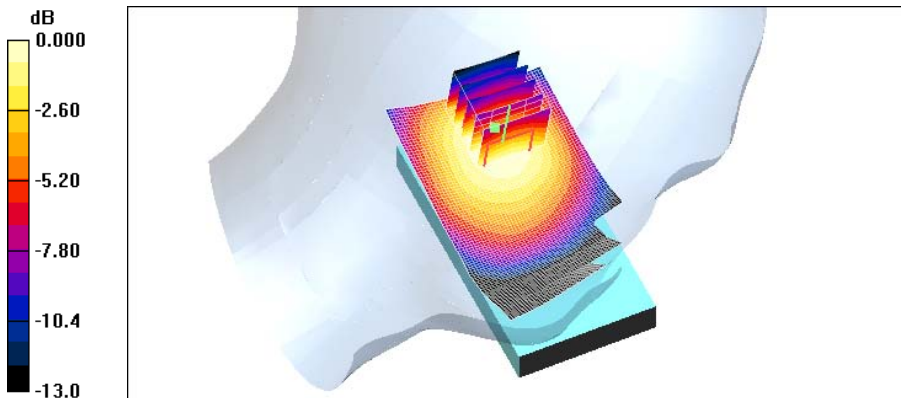

0 dB = 0.204mW/g

Test Laboratory: HCT CO., LTD
EUT Type: CDMA/LTE Phone with Bluetooth & WLAN
Liquid Temperature: 21.2 °C
Ambient Temperature: 21.4 °C
Test Date: May.06, 2011

DUT: ADR8995; Type: Bar; Serial: #1

Communication System: LTE; Frequency: 782 MHz; Duty Cycle: 1:1
Medium parameters used: $f = 782.5$ MHz; $\sigma = 0.893$ mho/m; $\epsilon_r = 41.7$; $\rho = 1000$ kg/m³
Phantom section: Left Section ; Measurement SW: DASY4, V4.7 Build 71; Postprocessing SW: SEMCAD, V1.8 Build 184

DASY4 Configuration:

- Probe: ES3DV3 - SN3161; ConvF(6.1, 6.1, 6.1); Calibrated: 2011-03-17
- Sensor-Surface: 4mm (Mechanical Surface Detection)
- Electronics: DAE3 Sn466; Calibrated: 2011-03-01
- Phantom: 835/900 Phantom ; Type: SAM

Left Tilt 23230 16QAM 25 13/Area Scan (51x91x1): Measurement grid: dx=15mm, dy=15mm
MMaximum value of SAR (interpolated) = 0.198 mW/g

Left Tilt 23230 16QAM 25 13/Zoom Scan (5x5x7)/Cube 0: Measurement grid: dx=8mm, dy=8mm, dz=5mm
Reference Value = 13.7 V/m; Power Drift = -0.004 dB
Peak SAR (extrapolated) = 0.290 W/kg
SAR(1 g) = 0.166 mW/g; SAR(10 g) = 0.110 mW/g
Maximum value of SAR (measured) = 0.177 mW/g

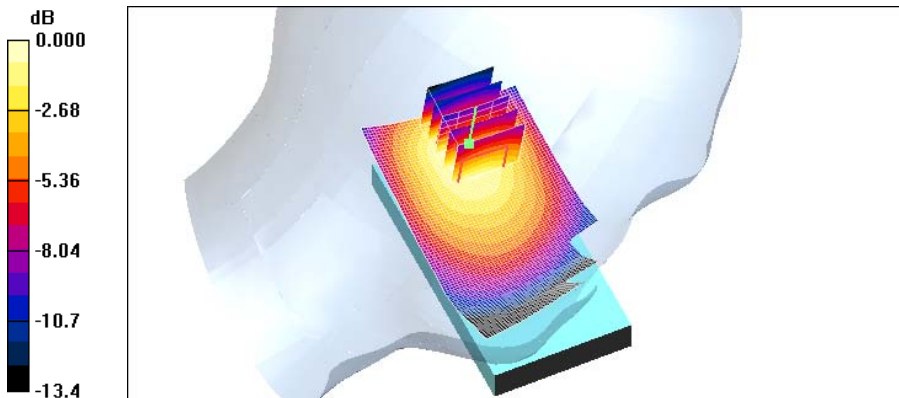

0 dB = 0.177mW/g

Test Laboratory: HCT CO., LTD
EUT Type: CDMA/LTE Phone with Bluetooth & WLAN
Liquid Temperature: 21.2 °C
Ambient Temperature: 21.4 °C
Test Date: May.06, 2011

DUT: ADR8995; Type: Bar; Serial: #1

Communication System: LTE; Frequency: 782 MHz; Duty Cycle: 1:1
Medium parameters used: $f = 782.5$ MHz; $\sigma = 0.893$ mho/m; $\epsilon_r = 41.7$; $\rho = 1000$ kg/m³
Phantom section: Right Section ; Measurement SW: DASY4, V4.7 Build 71; Postprocessing SW: SEMCAD, V1.8 Build 184

DASY4 Configuration:

- Probe: ES3DV3 - SN3161; ConvF(6.1, 6.1, 6.1); Calibrated: 2011-03-17
- Sensor-Surface: 4mm (Mechanical Surface Detection)
- Electronics: DAE3 Sn466; Calibrated: 2011-03-01
- Phantom: 835/900 Phantom ; Type: SAM

Right Touch 23230 16QAM 1 0/Area Scan (51x91x1): Measurement grid: dx=15mm, dy=15mm
MMaximum value of SAR (interpolated) = 0.182 mW/g

Right Touch 23230 16QAM 1 0/Zoom Scan (5x5x7)/Cube 0: Measurement grid: dx=8mm, dy=8mm, dz=5mm
Reference Value = 14.2 V/m; Power Drift = -0.035 dB
Peak SAR (extrapolated) = 0.253 W/kg
SAR(1 g) = 0.172 mW/g; SAR(10 g) = 0.122 mW/g
Maximum value of SAR (measured) = 0.180 mW/g

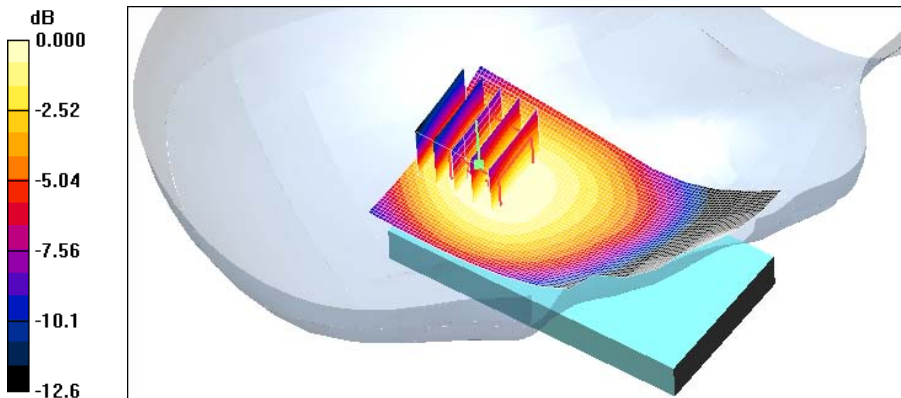

0 dB = 0.180mW/g

Test Laboratory: HCT CO., LTD
EUT Type: CDMA/LTE Phone with Bluetooth & WLAN
Liquid Temperature: 21.2 °C
Ambient Temperature: 21.4 °C
Test Date: May.06, 2011

DUT: ADR8995; Type: Bar; Serial: #1

Communication System: LTE; Frequency: 782 MHz; Duty Cycle: 1:1
Medium parameters used: $f = 782.5$ MHz; $\sigma = 0.893$ mho/m; $\epsilon_r = 41.7$; $\rho = 1000$ kg/m³
Phantom section: Right Section ; Measurement SW: DASY4, V4.7 Build 71; Postprocessing SW: SEMCAD, V1.8 Build 184

DASY4 Configuration:

- Probe: ES3DV3 - SN3161; ConvF(6.1, 6.1, 6.1); Calibrated: 2011-03-17
- Sensor-Surface: 4mm (Mechanical Surface Detection)
- Electronics: DAE3 Sn466; Calibrated: 2011-03-01
- Phantom: 835/900 Phantom ; Type: SAM

Right Tilt 23230 16QAM 1 0/Area Scan (51x91x1): Measurement grid: dx=15mm, dy=15mm
MMaximum value of SAR (interpolated) = 0.161 mW/g

Right Tilt 23230 16QAM 1 0/Zoom Scan (5x5x7)/Cube 0: Measurement grid: dx=8mm, dy=8mm, dz=5mm
Reference Value = 13.1 V/m; Power Drift = 0.023 dB
Peak SAR (extrapolated) = 0.220 W/kg
SAR(1 g) = 0.146 mW/g; SAR(10 g) = 0.102 mW/g
Maximum value of SAR (measured) = 0.156 mW/g

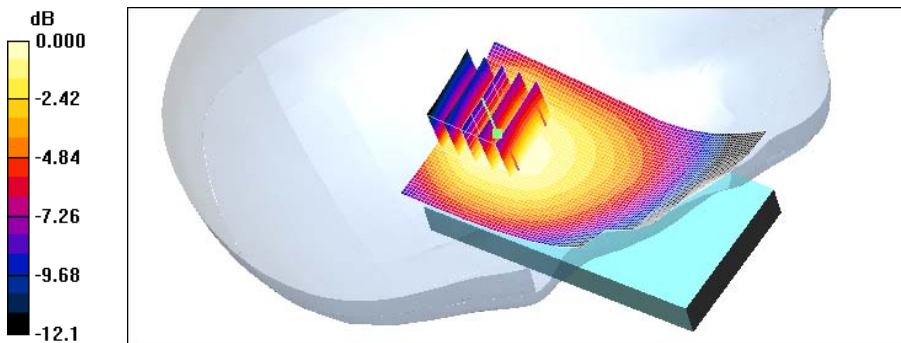

0 dB = 0.156mW/g

Test Laboratory: HCT CO., LTD
EUT Type: CDMA/LTE Phone with Bluetooth & WLAN
Liquid Temperature: 21.2 °C
Ambient Temperature: 21.4 °C
Test Date: May.06, 2011

DUT: ADR8995; Type: Bar; Serial: #1

Communication System: LTE; Frequency: 782 MHz; Duty Cycle: 1:1
Medium parameters used: $f = 782.5$ MHz; $\sigma = 0.893$ mho/m; $\epsilon_r = 41.7$; $\rho = 1000$ kg/m³
Phantom section: Right Section ; Measurement SW: DASY4, V4.7 Build 71; Postprocessing SW: SEMCAD, V1.8 Build 184

DASY4 Configuration:

- Probe: ES3DV3 - SN3161; ConvF(6.1, 6.1, 6.1); Calibrated: 2011-03-17
- Sensor-Surface: 4mm (Mechanical Surface Detection)
- Electronics: DAE3 Sn466; Calibrated: 2011-03-01
- Phantom: 835/900 Phantom ; Type: SAM

Right Touch 23230 16QAM 1 49/Area Scan (51x91x1): Measurement grid: dx=15mm, dy=15mm
MMaximum value of SAR (interpolated) = 0.232 mW/g

Right Touch 23230 16QAM 1 49/Zoom Scan (5x5x7)/Cube 0: Measurement grid: dx=8mm, dy=8mm, dz=5mm
Reference Value = 15.8 V/m; Power Drift = -0.012 dB
Peak SAR (extrapolated) = 0.333 W/kg
SAR(1 g) = 0.219 mW/g; SAR(10 g) = 0.153 mW/g
Maximum value of SAR (measured) = 0.232 mW/g

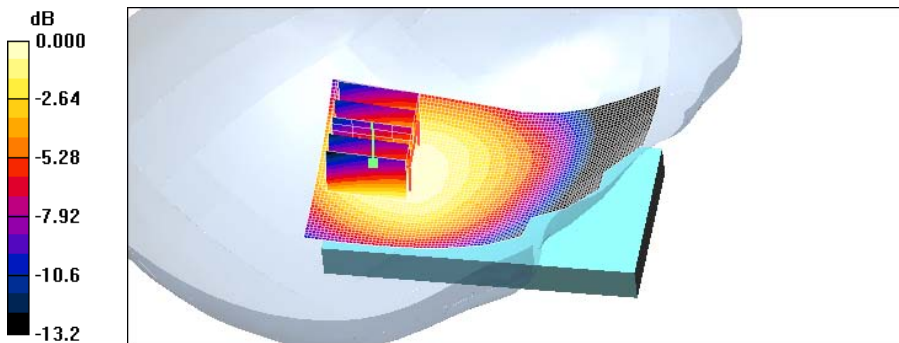

0 dB = 0.232mW/g

Test Laboratory: HCT CO., LTD
EUT Type: CDMA/LTE Phone with Bluetooth & WLAN
Liquid Temperature: 21.2 °C
Ambient Temperature: 21.4 °C
Test Date: May.06, 2011

DUT: ADR8995; Type: Bar; Serial: #1

Communication System: LTE; Frequency: 782 MHz; Duty Cycle: 1:1
Medium parameters used: $f = 782.5$ MHz; $\sigma = 0.893$ mho/m; $\epsilon_r = 41.7$; $\rho = 1000$ kg/m³
Phantom section: Right Section ; Measurement SW: DASY4, V4.7 Build 71; Postprocessing SW: SEMCAD, V1.8 Build 184

DASY4 Configuration:

- Probe: ES3DV3 - SN3161; ConvF(6.1, 6.1, 6.1); Calibrated: 2011-03-17
- Sensor-Surface: 4mm (Mechanical Surface Detection)
- Electronics: DAE3 Sn466; Calibrated: 2011-03-01
- Phantom: 835/900 Phantom ; Type: SAM

Right Tilt 23230 16QAM 1 49/Area Scan (51x91x1): Measurement grid: dx=15mm, dy=15mm
MMaximum value of SAR (interpolated) = 0.193 mW/g

Right Tilt 23230 16QAM 1 49/Zoom Scan (5x5x7)/Cube 0: Measurement grid: dx=8mm, dy=8mm, dz=5mm
Reference Value = 14.4 V/m; Power Drift = -0.162 dB
Peak SAR (extrapolated) = 0.245 W/kg
SAR(1 g) = 0.175 mW/g; SAR(10 g) = 0.121 mW/g
Maximum value of SAR (measured) = 0.187 mW/g

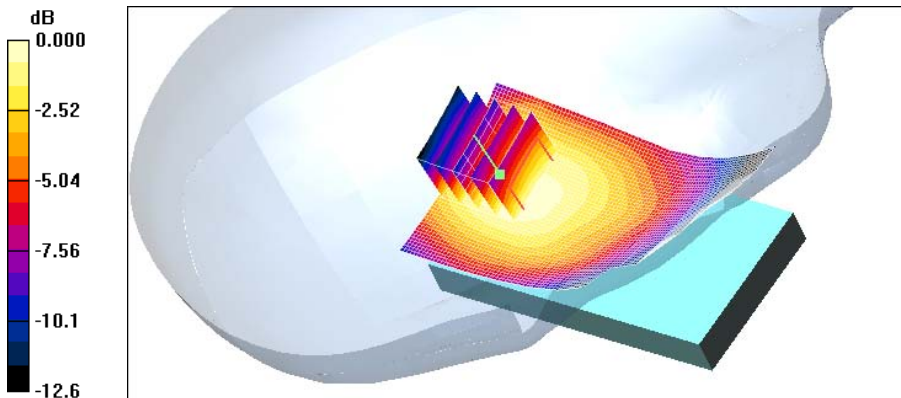

0 dB = 0.187mW/g

Test Laboratory: HCT CO., LTD
EUT Type: CDMA/LTE Phone with Bluetooth & WLAN
Liquid Temperature: 21.2 °C
Ambient Temperature: 21.4 °C
Test Date: May.06, 2011

DUT: ADR8995; Type: Bar; Serial: #1

Communication System: LTE; Frequency: 782 MHz; Duty Cycle: 1:1
Medium parameters used: $f = 782.5$ MHz; $\sigma = 0.893$ mho/m; $\epsilon_r = 41.7$; $\rho = 1000$ kg/m³
Phantom section: Right Section ; Measurement SW: DASY4, V4.7 Build 71; Postprocessing SW: SEMCAD, V1.8 Build 184

DASY4 Configuration:

- Probe: ES3DV3 - SN3161; ConvF(6.1, 6.1, 6.1); Calibrated: 2011-03-17
- Sensor-Surface: 4mm (Mechanical Surface Detection)
- Electronics: DAE3 Sn466; Calibrated: 2011-03-01
- Phantom: 835/900 Phantom ; Type: SAM

Right Touch 23230 16QAM 25 13/Area Scan (51x91x1): Measurement grid: dx=15mm, dy=15mm
MMaximum value of SAR (interpolated) = 0.170 mW/g

Right Touch 23230 16QAM 25 13/Zoom Scan (5x5x7)/Cube 0: Measurement grid: dx=8mm, dy=8mm, dz=5mm
Reference Value = 13.4 V/m; Power Drift = 0.083 dB
Peak SAR (extrapolated) = 0.237 W/kg
SAR(1 g) = 0.160 mW/g; SAR(10 g) = 0.113 mW/g
Maximum value of SAR (measured) = 0.169 mW/g

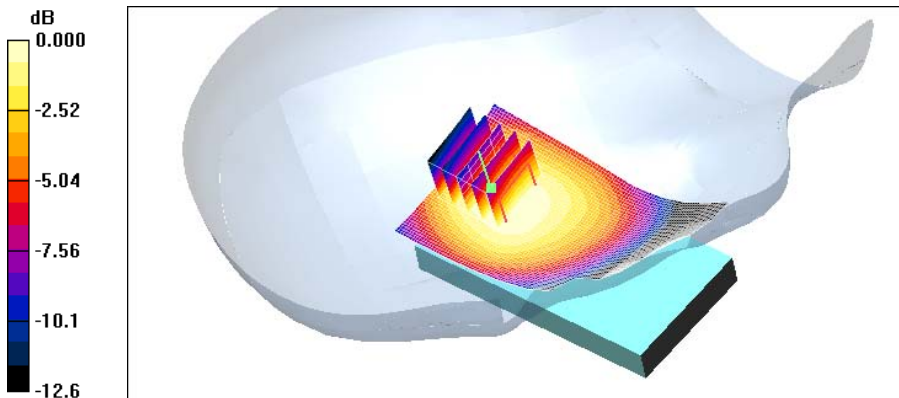

0 dB = 0.169mW/g

Test Laboratory: HCT CO., LTD
EUT Type: CDMA/LTE Phone with Bluetooth & WLAN
Liquid Temperature: 21.2 °C
Ambient Temperature: 21.4 °C
Test Date: May.06, 2011

DUT: ADR8995; Type: Bar; Serial: #1

Communication System: LTE; Frequency: 782 MHz; Duty Cycle: 1:1
Medium parameters used: $f = 782.5$ MHz; $\sigma = 0.893$ mho/m; $\epsilon_r = 41.7$; $\rho = 1000$ kg/m³
Phantom section: Right Section ; Measurement SW: DASY4, V4.7 Build 71; Postprocessing SW: SEMCAD, V1.8 Build 184

DASY4 Configuration:

- Probe: ES3DV3 - SN3161; ConvF(6.1, 6.1, 6.1); Calibrated: 2011-03-17
- Sensor-Surface: 4mm (Mechanical Surface Detection)
- Electronics: DAE3 Sn466; Calibrated: 2011-03-01
- Phantom: 835/900 Phantom ; Type: SAM

Right Touch 23230 16QAM 25 13/Area Scan (51x91x1): Measurement grid: dx=15mm, dy=15mm
MMaximum value of SAR (interpolated) = 0.138 mW/g

Right Touch 23230 16QAM 25 13/Zoom Scan (5x5x7)/Cube 0: Measurement grid: dx=8mm, dy=8mm, dz=5mm
Reference Value = 12.2 V/m; Power Drift = 0.000 dB
Peak SAR (extrapolated) = 0.192 W/kg
SAR(1 g) = 0.128 mW/g; SAR(10 g) = 0.089 mW/g
Maximum value of SAR (measured) = 0.136 mW/g

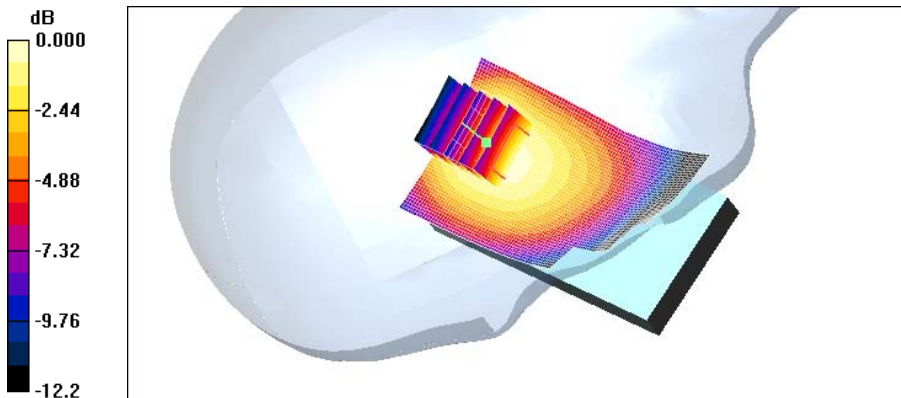

0 dB = 0.136mW/g

Test Laboratory: HCT CO., LTD
EUT Type: CDMA/LTE Phone with Bluetooth & WLAN
Liquid Temperature: 21.2 °C
Ambient Temperature: 21.4 °C
Test Date: Jun.10, 2011

DUT: ADR8995; Type: Bar; Serial: #1

Communication System: 2450MHz FCC; Frequency: 2437 MHz;Duty Cycle: 1:1
Medium parameters used (interpolated): $f = 2437$ MHz; $\sigma = 1.85$ mho/m; $\epsilon_r = 38.4$; $\rho = 1000$ kg/m³
Phantom section: Left Section ; Measurement SW: DASY4, V4.7 Build 71; Postprocessing SW: SEMCAD, V1.8 Build 184

DASY4 Configuration:

- Probe: ES3DV3 - SN3161; ConvF(4.26, 4.26, 4.26); Calibrated: 2011-03-17
- Sensor-Surface: 4mm (Mechanical Surface Detection)
- Electronics: DAE3 Sn466; Calibrated: 2011-03-01
- Phantom: 1800/1900 Phantom; Type: SAM

Left Touch 6ch/Area Scan (61x91x1): Measurement grid: dx=15mm, dy=15mm

[Info: Interpolated medium parameters used for SAR evaluation.](#)

Maximum value of SAR (interpolated) = 0.294 mW/g

Left Touch 6ch/Zoom Scan (5x5x7)/Cube 0: Measurement grid: dx=8mm, dy=8mm, dz=5mm

Reference Value = 6.20 V/m; Power Drift = -0.02 dB

Peak SAR (extrapolated) = 0.660 W/kg

SAR(1 g) = 0.261 mW/g; SAR(10 g) = 0.113 mW/g

[Info: Interpolated medium parameters used for SAR evaluation.](#)

Maximum value of SAR (measured) = 0.293 mW/g

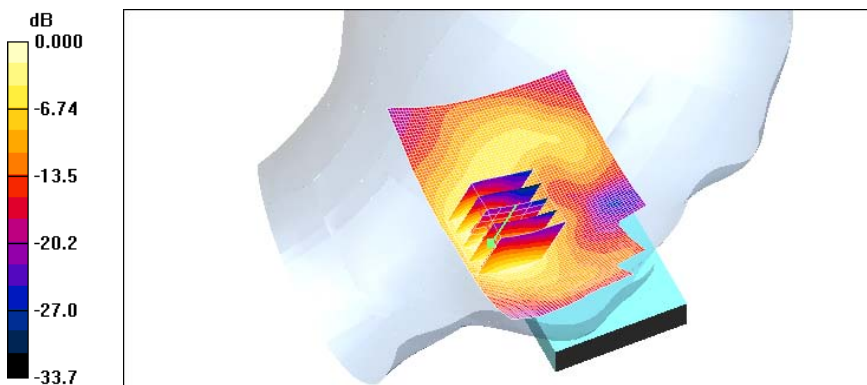

0 dB = 0.293mW/g

Test Laboratory: HCT CO., LTD
EUT Type: CDMA/LTE Phone with Bluetooth & WLAN
Liquid Temperature: 21.2 °C
Ambient Temperature: 21.4 °C
Test Date: Jun.10, 2011

DUT: ADR8995; Type: Bar; Serial: #1

Communication System: 2450MHz FCC; Frequency: 2437 MHz; Duty Cycle: 1:1
Medium parameters used (interpolated): $f = 2437$ MHz; $\sigma = 1.85$ mho/m; $\epsilon_r = 38.4$; $\rho = 1000$ kg/m³
Phantom section: Left Section ; Measurement SW: DASY4, V4.7 Build 71; Postprocessing SW: SEMCAD, V1.8 Build 184

DASY4 Configuration:

- Probe: ES3DV3 - SN3161; ConvF(4.26, 4.26, 4.26); Calibrated: 2011-03-17
- Sensor-Surface: 4mm (Mechanical Surface Detection)
- Electronics: DAE3 Sn466; Calibrated: 2011-03-01
- Phantom: 1800/1900 Phantom; Type: SAM

Left Tilt 6ch/Area Scan (61x91x1): Measurement grid: dx=15mm, dy=15mm

[Info: Interpolated medium parameters used for SAR evaluation.](#)

Maximum value of SAR (interpolated) = 0.098 mW/g

Left Tilt 6ch/Zoom Scan (5x5x7)/Cube 0: Measurement grid: dx=8mm, dy=8mm, dz=5mm

Reference Value = 7.07 V/m; Power Drift = -0.071 dB

Peak SAR (extrapolated) = 0.177 W/kg

SAR(1 g) = 0.085 mW/g; SAR(10 g) = 0.042 mW/g

[Info: Interpolated medium parameters used for SAR evaluation.](#)

Maximum value of SAR (measured) = 0.095 mW/g

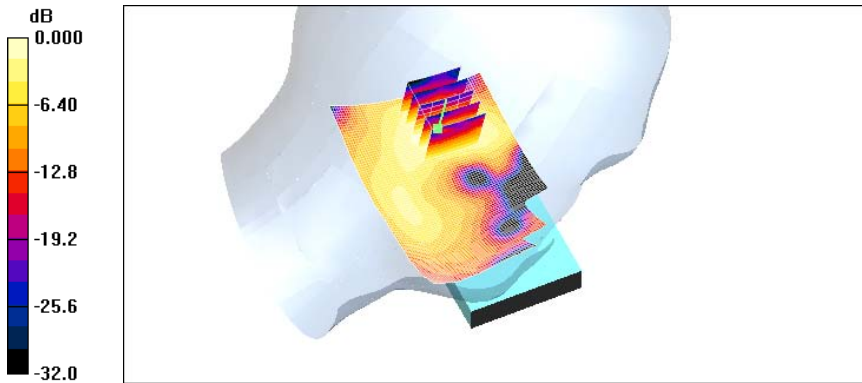

0 dB = 0.095mW/g

Test Laboratory: HCT CO., LTD
EUT Type: CDMA/LTE Phone with Bluetooth & WLAN
Liquid Temperature: 21.2 °C
Ambient Temperature: 21.4 °C
Test Date: Jun.10, 2011

DUT: ADR8995; Type: Bar; Serial: #1

Communication System: 2450MHz FCC; Frequency: 2437 MHz; Duty Cycle: 1:1
Medium parameters used (interpolated): $f = 2437$ MHz; $\sigma = 1.82$ mho/m; $\epsilon_r = 39.8$; $\rho = 1000$ kg/m³
Phantom section: Right Section ; Measurement SW: DASY4, V4.7 Build 71; Postprocessing SW: SEMCAD, V1.8 Build 184

DASY4 Configuration:

- Probe: ES3DV3 - SN3161; ConvF(4.26, 4.26, 4.26); Calibrated: 2011-03-17
- Sensor-Surface: 4mm (Mechanical Surface Detection)
- Electronics: DAE3 Sn466; Calibrated: 2011-03-01
- Phantom: 1800/1900 Phantom; Type: SAM

Right touch 6ch/Area Scan (71x91x1): Measurement grid: dx=15mm, dy=15mm

[Info: Interpolated medium parameters used for SAR evaluation.](#)

Maximum value of SAR (interpolated) = 0.097 mW/g

Right touch 6ch/Zoom Scan (5x5x7)/Cube 0: Measurement grid: dx=8mm, dy=8mm, dz=5mm

Reference Value = 2.84 V/m; Power Drift = 0.013 dB

Peak SAR (extrapolated) = 0.170 W/kg

SAR(1 g) = 0.084 mW/g; SAR(10 g) = 0.038 mW/g

[Info: Interpolated medium parameters used for SAR evaluation.](#)

Maximum value of SAR (measured) = 0.098 mW/g

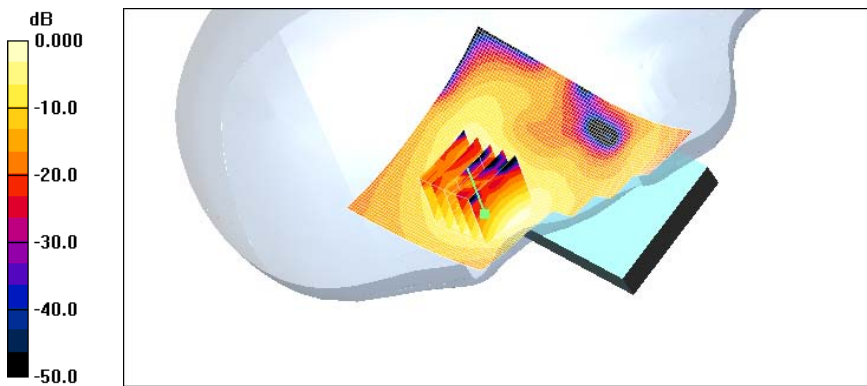

0 dB = 0.098mW/g

Test Laboratory: HCT CO., LTD
EUT Type: CDMA/LTE Phone with Bluetooth & WLAN
Liquid Temperature: 21.2 °C
Ambient Temperature: 21.4 °C
Test Date: Jun.10, 2011

DUT: ADR8995; Type: Bar; Serial: #1

Communication System: 2450MHz FCC; Frequency: 2437 MHz; Duty Cycle: 1:1
Medium parameters used (interpolated): $f = 2437$ MHz; $\sigma = 1.82$ mho/m; $\epsilon_r = 39.8$; $\rho = 1000$ kg/m³
Phantom section: Right Section ; Measurement SW: DASY4, V4.7 Build 71; Postprocessing SW: SEMCAD, V1.8 Build 184

DASY4 Configuration:

- Probe: ES3DV3 - SN3161; ConvF(4.26, 4.26, 4.26); Calibrated: 2011-03-17
- Sensor-Surface: 4mm (Mechanical Surface Detection)
- Electronics: DAE3 Sn466; Calibrated: 2011-03-01
- Phantom: 1800/1900 Phantom; Type: SAM

Right tilt 6ch/Area Scan (61x91x1): Measurement grid: dx=15mm, dy=15mm

[Info: Interpolated medium parameters used for SAR evaluation.](#)

Maximum value of SAR (interpolated) = 0.041 mW/g

Right tilt 6ch/Zoom Scan (5x5x7)/Cube 0: Measurement grid: dx=8mm, dy=8mm, dz=5mm

Reference Value = 4.55 V/m; Power Drift = -0.02 dB

Peak SAR (extrapolated) = 0.061 W/kg

SAR(1 g) = 0.036 mW/g; SAR(10 g) = 0.017 mW/g

[Info: Interpolated medium parameters used for SAR evaluation.](#)

Maximum value of SAR (measured) = 0.043 mW/g

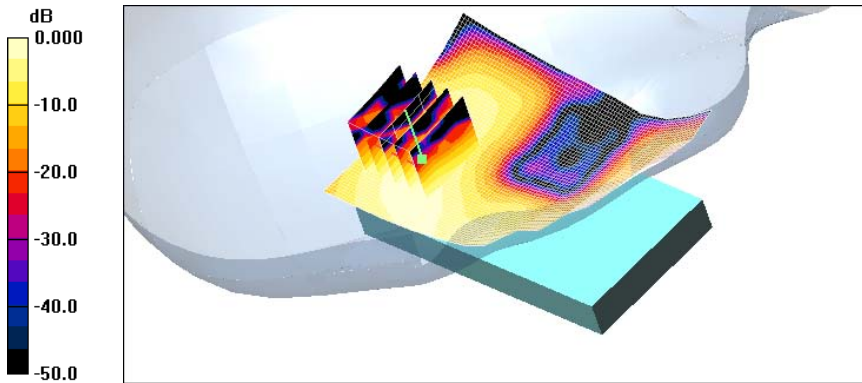

0 dB = 0.043mW/g

Test Laboratory: HCT CO., LTD
EUT Type: CDMA/LTE Phone with Bluetooth & WLAN
Liquid Temperature: 21.3 °C
Ambient Temperature: 21.5 °C
Test Date: Jun.08, 2011

DUT: ADR8995; Type: Bar; Serial: #1

Communication System: CDMA 835MHz FCC; Frequency: 836.52 MHz; Duty Cycle: 1:1
Medium parameters used (interpolated): $f = 836.52$ MHz; $\sigma = 0.982$ mho/m; $\epsilon_r = 56.8$; $\rho = 1000$ kg/m³
Phantom section: Flat Section ; Measurement SW: DASY4, V4.7 Build 71; Postprocessing SW: SEMCAD, V1.8 Build 184

DASY4 Configuration:

- Probe: ES3DV3 - SN3161; ConvF(5.86, 5.86, 5.86); Calibrated: 2011-03-17
- Sensor-Surface: 4mm (Mechanical Surface Detection)
- Electronics: DAE3 Sn466; Calibrated: 2011-03-01
- Phantom: 800/900 Phantom; Type: SAM

CDMA Body Front 384/Area Scan (51x91x1): Measurement grid: dx=15mm, dy=15mm

[Info: Interpolated medium parameters used for SAR evaluation.](#)

Maximum value of SAR (interpolated) = 0.395 mW/g

CDMA Body Front 384/Zoom Scan (5x5x7)/Cube 0: Measurement grid: dx=8mm, dy=8mm, dz=5mm

Reference Value = 12.1 V/m; Power Drift = -0.040 dB

Peak SAR (extrapolated) = 0.477 W/kg

SAR(1 g) = 0.379 mW/g; SAR(10 g) = 0.285 mW/g

[Info: Interpolated medium parameters used for SAR evaluation.](#)

Maximum value of SAR (measured) = 0.398 mW/g

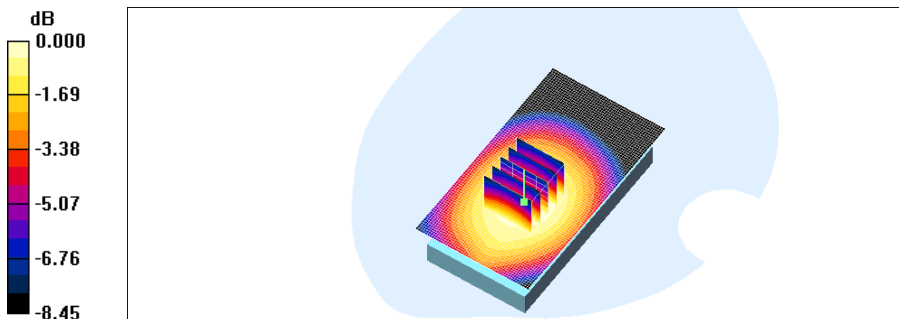

Test Laboratory: HCT CO., LTD
EUT Type: CDMA/LTE Phone with Bluetooth & WLAN
Liquid Temperature: 21.3 °C
Ambient Temperature: 21.5 °C
Test Date: Jun.08, 2011

DUT: ADR8995; Type: Bar; Serial: #1

Communication System: CDMA 835MHz FCC; Frequency: 836.52 MHz; Duty Cycle: 1:1
Medium parameters used (interpolated): $f = 836.52$ MHz; $\sigma = 0.982$ mho/m; $\epsilon_r = 56.8$; $\rho = 1000$ kg/m³
Phantom section: Flat Section ; Measurement SW: DASY4, V4.7 Build 71; Postprocessing SW: SEMCAD, V1.8 Build 184

DASY4 Configuration:

- Probe: ES3DV3 - SN3161; ConvF(5.86, 5.86, 5.86); Calibrated: 2011-03-17
- Sensor-Surface: 4mm (Mechanical Surface Detection)
- Electronics: DAE3 Sn466; Calibrated: 2011-03-01
- Phantom: 800/900 Phantom; Type: SAM

CDMA Body Rear 384/Area Scan (51x91x1): Measurement grid: dx=15mm, dy=15mm

[Info: Interpolated medium parameters used for SAR evaluation.](#)

Maximum value of SAR (interpolated) = 0.718 mW/g

CDMA Body Rear 384/Zoom Scan (5x5x7)/Cube 0: Measurement grid: dx=8mm, dy=8mm, dz=5mm

Reference Value = 15.6 V/m; Power Drift = -0.02 dB

Peak SAR (extrapolated) = 1.10 W/kg

SAR(1 g) = 0.654 mW/g; SAR(10 g) = 0.390 mW/g

[Info: Interpolated medium parameters used for SAR evaluation.](#)

Maximum value of SAR (measured) = 0.714 mW/g

CDMA Body Rear 384/Zoom Scan (5x5x7)/Cube 1: Measurement grid: dx=8mm, dy=8mm, dz=5mm

Reference Value = 15.6 V/m; Power Drift = -0.02 dB

Peak SAR (extrapolated) = 0.764 W/kg

SAR(1 g) = 0.595 mW/g; SAR(10 g) = 0.435 mW/g

[Info: Interpolated medium parameters used for SAR evaluation.](#)

Maximum value of SAR (measured) = 0.628 mW/g

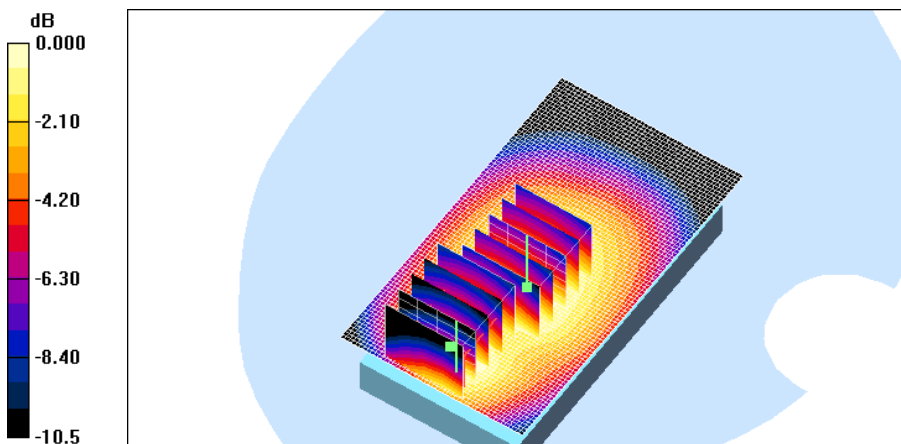

0 dB = 0.628mW/g

Test Laboratory: HCT CO., LTD
EUT Type: CDMA/LTE Phone with Bluetooth & WLAN
Liquid Temperature: 21.3 °C
Ambient Temperature: 21.5 °C
Test Date: Jun.08, 2011

DUT: ADR8995; Type: Bar; Serial: #1

Communication System: CDMA 835MHz FCC; Frequency: 836.52 MHz; Duty Cycle: 1:1
Medium parameters used (interpolated): $f = 836.52$ MHz; $\sigma = 0.982$ mho/m; $\epsilon_r = 56.8$; $\rho = 1000$ kg/m³
Phantom section: Flat Section ; Measurement SW: DASY4, V4.7 Build 71; Postprocessing SW: SEMCAD, V1.8 Build 184

DASY4 Configuration:

- Probe: ES3DV3 - SN3161; ConvF(5.86, 5.86, 5.86); Calibrated: 2011-03-17
- Sensor-Surface: 4mm (Mechanical Surface Detection)
- Electronics: DAE3 Sn466; Calibrated: 2011-03-01
- Phantom: 800/900 Phantom; Type: SAM

CDMA Body Left side 384/Area Scan (41x91x1): Measurement grid: dx=15mm, dy=15mm

[Info: Interpolated medium parameters used for SAR evaluation.](#)

Maximum value of SAR (interpolated) = 0.378 mW/g

CDMA Body Left side 384/Zoom Scan (5x5x7)/Cube 0: Measurement grid: dx=8mm, dy=8mm, dz=5mm

Reference Value = 14.9 V/m; Power Drift = -0.064 dB

Peak SAR (extrapolated) = 0.491 W/kg

SAR(1 g) = 0.352 mW/g; SAR(10 g) = 0.240 mW/g

[Info: Interpolated medium parameters used for SAR evaluation.](#)

Maximum value of SAR (measured) = 0.375 mW/g

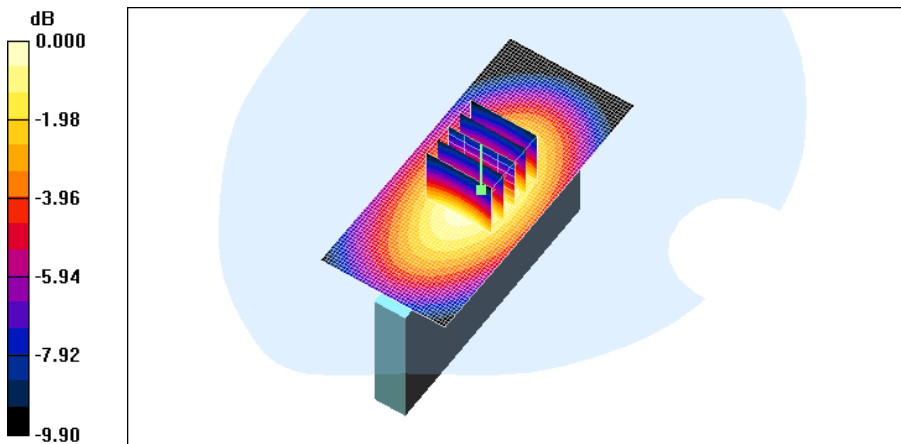

Test Laboratory: HCT CO., LTD
EUT Type: CDMA/LTE Phone with Bluetooth & WLAN
Liquid Temperature: 21.3 °C
Ambient Temperature: 21.5 °C
Test Date: Jun.08, 2011

DUT: ADR8995; Type: Bar; Serial: #1

Communication System: CDMA 835MHz FCC; Frequency: 836.52 MHz; Duty Cycle: 1:1
Medium parameters used (interpolated): $f = 836.52$ MHz; $\sigma = 0.982$ mho/m; $\epsilon_r = 56.8$; $\rho = 1000$ kg/m³
Phantom section: Flat Section ; Measurement SW: DASY4, V4.7 Build 71; Postprocessing SW: SEMCAD, V1.8 Build 184

DASY4 Configuration:

- Probe: ES3DV3 - SN3161; ConvF(5.86, 5.86, 5.86); Calibrated: 2011-03-17
- Sensor-Surface: 4mm (Mechanical Surface Detection)
- Electronics: DAE3 Sn466; Calibrated: 2011-03-01
- Phantom: 800/900 Phantom; Type: SAM

CDMA Body Right side 384/Area Scan (41x91x1): Measurement grid: dx=15mm, dy=15mm

[Info: Interpolated medium parameters used for SAR evaluation.](#)

Maximum value of SAR (interpolated) = 0.468 mW/g

CDMA Body Right side 384/Zoom Scan (5x5x7)/Cube 0: Measurement grid: dx=8mm, dy=8mm, dz=5mm

Reference Value = 16.2 V/m; Power Drift = -0.082 dB

Peak SAR (extrapolated) = 0.599 W/kg

SAR(1 g) = 0.438 mW/g; SAR(10 g) = 0.303 mW/g

[Info: Interpolated medium parameters used for SAR evaluation.](#)

Maximum value of SAR (measured) = 0.468 mW/g

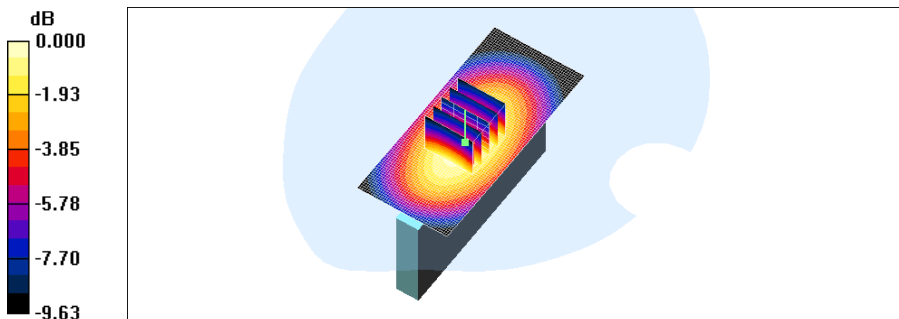

0 dB = 0.468mW/g

Test Laboratory: HCT CO., LTD
EUT Type: CDMA/LTE Phone with Bluetooth & WLAN
Liquid Temperature: 21.3 °C
Ambient Temperature: 21.5 °C
Test Date: Jun.08, 2011

DUT: ADR8995; Type: Bar; Serial: #1

Communication System: CDMA 835MHz FCC; Frequency: 836.52 MHz; Duty Cycle: 1:1
Medium parameters used (interpolated): $f = 836.52$ MHz; $\sigma = 0.982$ mho/m; $\epsilon_r = 56.8$; $\rho = 1000$ kg/m³
Phantom section: Flat Section ; Measurement SW: DASY4, V4.7 Build 71; Postprocessing SW: SEMCAD, V1.8 Build 184

DASY4 Configuration:

- Probe: ES3DV3 - SN3161; ConvF(5.86, 5.86, 5.86); Calibrated: 2011-03-17
- Sensor-Surface: 4mm (Mechanical Surface Detection)
- Electronics: DAE3 Sn466; Calibrated: 2011-03-01
- Phantom: 800/900 Phantom; Type: SAM

CDMA Body Bottom side 384/Area Scan (41x61x1): Measurement grid: dx=15mm, dy=15mm

[Info: Interpolated medium parameters used for SAR evaluation.](#)

Maximum value of SAR (interpolated) = 0.127 mW/g

CDMA Body Bottom side 384/Zoom Scan (5x5x7)/Cube 0: Measurement grid: dx=8mm, dy=8mm, dz=5mm

Reference Value = 9.12 V/m; Power Drift = -0.134 dB

Peak SAR (extrapolated) = 0.189 W/kg

SAR(1 g) = 0.116 mW/g; SAR(10 g) = 0.070 mW/g

[Info: Interpolated medium parameters used for SAR evaluation.](#)

Maximum value of SAR (measured) = 0.123 mW/g

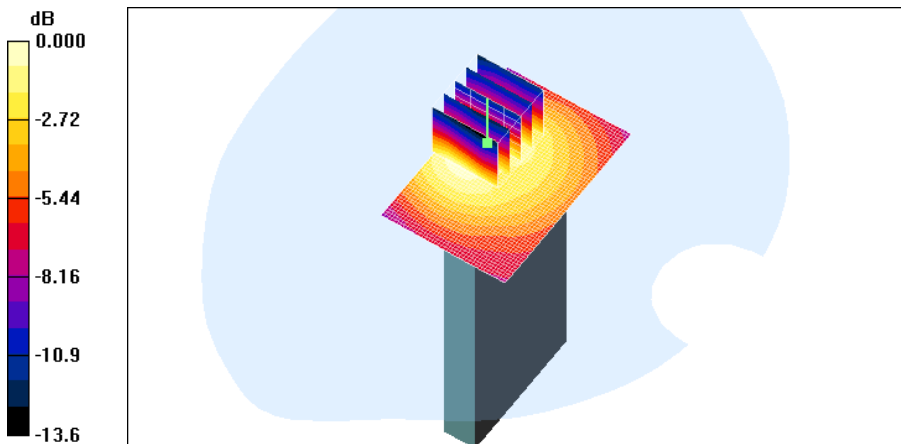

0 dB = 0.123mW/g

Test Laboratory: HCT CO., LTD
EUT Type: CDMA/LTE Phone with Bluetooth & WLAN
Liquid Temperature: 21.3 °C
Ambient Temperature: 21.5 °C
Test Date: Jun.08, 2011

DUT: ADR8995; Type: Bar; Serial: #1

Communication System: CDMA 835MHz FCC; Frequency: 836.52 MHz; Duty Cycle: 1:1
Medium parameters used (interpolated): $f = 836.52$ MHz; $\sigma = 0.982$ mho/m; $\epsilon_r = 56.8$; $\rho = 1000$ kg/m³
Phantom section: Flat Section ; Measurement SW: DASY4, V4.7 Build 71; Postprocessing SW: SEMCAD, V1.8 Build 184

DASY4 Configuration:

- Probe: ES3DV3 - SN3161; ConvF(5.86, 5.86, 5.86); Calibrated: 2011-03-17
- Sensor-Surface: 4mm (Mechanical Surface Detection)
- Electronics: DAE3 Sn466; Calibrated: 2011-03-01
- Phantom: 800/900 Phantom; Type: SAM

EVDO Body Front 384/Area Scan (51x91x1): Measurement grid: dx=15mm, dy=15mm

[Info: Interpolated medium parameters used for SAR evaluation.](#)

Maximum value of SAR (interpolated) = 0.283 mW/g

EVDO Body Front 384/Zoom Scan (5x5x7)/Cube 0: Measurement grid: dx=8mm, dy=8mm, dz=5mm

Reference Value = 16.2 V/m; Power Drift = 0.025 dB

Peak SAR (extrapolated) = 0.339 W/kg

SAR(1 g) = 0.271 mW/g; SAR(10 g) = 0.202 mW/g

[Info: Interpolated medium parameters used for SAR evaluation.](#)

Maximum value of SAR (measured) = 0.285 mW/g

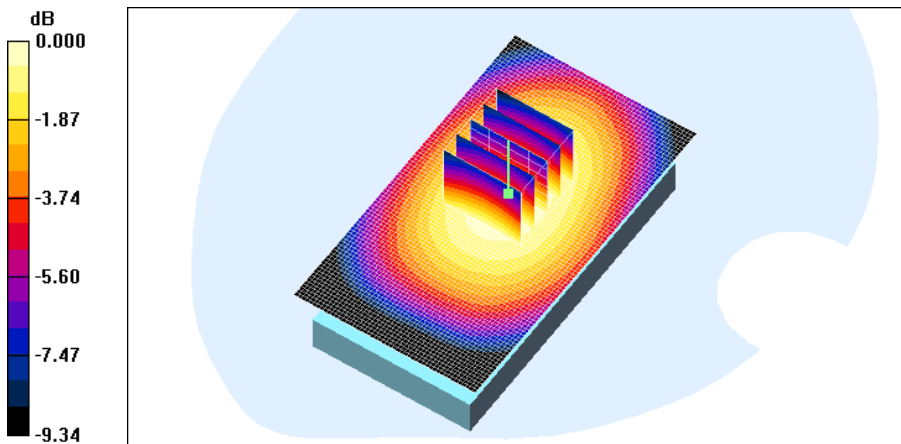

0 dB = 0.285mW/g

Test Laboratory: HCT CO., LTD
EUT Type: CDMA/LTE Phone with Bluetooth & WLAN
Liquid Temperature: 21.3 °C
Ambient Temperature: 21.5 °C
Test Date: Jun.08, 2011

DUT: ADR8995; Type: Bar; Serial: #1

Communication System: CDMA 835MHz FCC; Frequency: 836.52 MHz; Duty Cycle: 1:1
Medium parameters used (interpolated): $f = 836.52$ MHz; $\sigma = 0.982$ mho/m; $\epsilon_r = 56.8$; $\rho = 1000$ kg/m³
Phantom section: Flat Section ; Measurement SW: DASY4, V4.7 Build 71; Postprocessing SW: SEMCAD, V1.8 Build 184

DASY4 Configuration:

- Probe: ES3DV3 - SN3161; ConvF(5.86, 5.86, 5.86); Calibrated: 2011-03-17
- Sensor-Surface: 4mm (Mechanical Surface Detection)
- Electronics: DAE3 Sn466; Calibrated: 2011-03-01
- Phantom: 800/900 Phantom; Type: SAM

EVDO Body Rear 384/Area Scan (51x91x1): Measurement grid: dx=15mm, dy=15mm

[Info: Interpolated medium parameters used for SAR evaluation.](#)

Maximum value of SAR (interpolated) = 0.710 mW/g

EVDO Body Rear 384/Zoom Scan (5x5x7)/Cube 0: Measurement grid: dx=8mm, dy=8mm, dz=5mm

Reference Value = 23.3 V/m; Power Drift = 0.002 dB

Peak SAR (extrapolated) = 0.869 W/kg

SAR(1 g) = 0.670 mW/g; SAR(10 g) = 0.485 mW/g

[Info: Interpolated medium parameters used for SAR evaluation.](#)

Maximum value of SAR (measured) = 0.706 mW/g

EVDO Body Rear 384/Zoom Scan (5x5x7)/Cube 1: Measurement grid: dx=8mm, dy=8mm, dz=5mm

Reference Value = 23.3 V/m; Power Drift = 0.002 dB

Peak SAR (extrapolated) = 0.822 W/kg

SAR(1 g) = 0.585 mW/g; SAR(10 g) = 0.396 mW/g

Maximum value of SAR (measured) = 0.659 mW/g

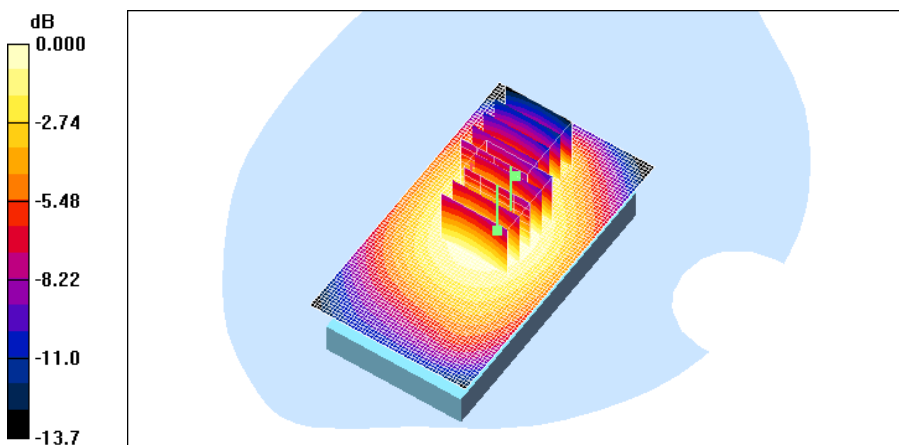

0 dB = 0.659mW/g

Test Laboratory: HCT CO., LTD
EUT Type: CDMA/LTE Phone with Bluetooth & WLAN
Liquid Temperature: 21.3 °C
Ambient Temperature: 21.5 °C
Test Date: Jun.08, 2011

DUT: ADR8995; Type: Bar; Serial: #1

Communication System: CDMA 835MHz FCC; Frequency: 836.52 MHz; Duty Cycle: 1:1
Medium parameters used (interpolated): $f = 836.52$ MHz; $\sigma = 0.982$ mho/m; $\epsilon_r = 56.8$; $\rho = 1000$ kg/m³
Phantom section: Flat Section ; Measurement SW: DASY4, V4.7 Build 71; Postprocessing SW: SEMCAD, V1.8 Build 184

DASY4 Configuration:

- Probe: ES3DV3 - SN3161; ConvF(5.86, 5.86, 5.86); Calibrated: 2011-03-17
- Sensor-Surface: 4mm (Mechanical Surface Detection)
- Electronics: DAE3 Sn466; Calibrated: 2011-03-01
- Phantom: 800/900 Phantom; Type: SAM

EVDO Body Left side 384/Area Scan (41x91x1): Measurement grid: dx=15mm, dy=15mm

[Info: Interpolated medium parameters used for SAR evaluation.](#)

Maximum value of SAR (interpolated) = 0.270 mW/g

EVDO Body Left side 384/Zoom Scan (5x5x7)/Cube 0: Measurement grid: dx=8mm, dy=8mm, dz=5mm

Reference Value = 14.2 V/m; Power Drift = -0.046 dB

Peak SAR (extrapolated) = 0.348 W/kg

SAR(1 g) = 0.250 mW/g; SAR(10 g) = 0.172 mW/g

[Info: Interpolated medium parameters used for SAR evaluation.](#)

Maximum value of SAR (measured) = 0.267 mW/g

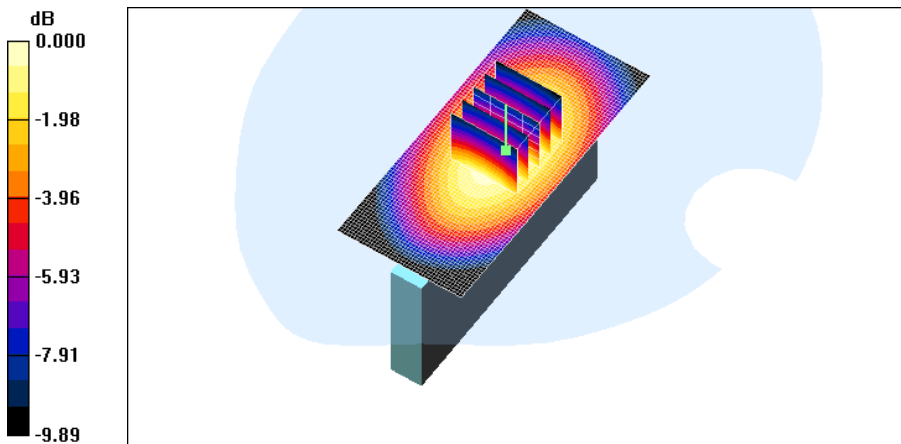

0 dB = 0.267mW/g

Test Laboratory: HCT CO., LTD
EUT Type: CDMA/LTE Phone with Bluetooth & WLAN
Liquid Temperature: 21.3 °C
Ambient Temperature: 21.5 °C
Test Date: Jun.08, 2011

DUT: ADR8995; Type: Bar; Serial: #1

Communication System: CDMA 835MHz FCC; Frequency: 836.52 MHz; Duty Cycle: 1:1
Medium parameters used (interpolated): $f = 836.52$ MHz; $\sigma = 0.982$ mho/m; $\epsilon_r = 56.8$; $\rho = 1000$ kg/m³
Phantom section: Flat Section ; Measurement SW: DASY4, V4.7 Build 71; Postprocessing SW: SEMCAD, V1.8 Build 184

DASY4 Configuration:

- Probe: ES3DV3 - SN3161; ConvF(5.86, 5.86, 5.86); Calibrated: 2011-03-17
- Sensor-Surface: 4mm (Mechanical Surface Detection)
- Electronics: DAE3 Sn466; Calibrated: 2011-03-01
- Phantom: 800/900 Phantom; Type: SAM

EVDO Body Right side 384/Area Scan (41x91x1): Measurement grid: dx=15mm, dy=15mm

[Info: Interpolated medium parameters used for SAR evaluation.](#)

Maximum value of SAR (interpolated) = 0.335 mW/g

EVDO Body Right side 384/Zoom Scan (5x5x7)/Cube 0: Measurement grid: dx=8mm, dy=8mm, dz=5mm

Reference Value = 15.6 V/m; Power Drift = 0.070 dB

Peak SAR (extrapolated) = 0.427 W/kg

SAR(1 g) = 0.309 mW/g; SAR(10 g) = 0.213 mW/g

[Info: Interpolated medium parameters used for SAR evaluation.](#)

Maximum value of SAR (measured) = 0.330 mW/g

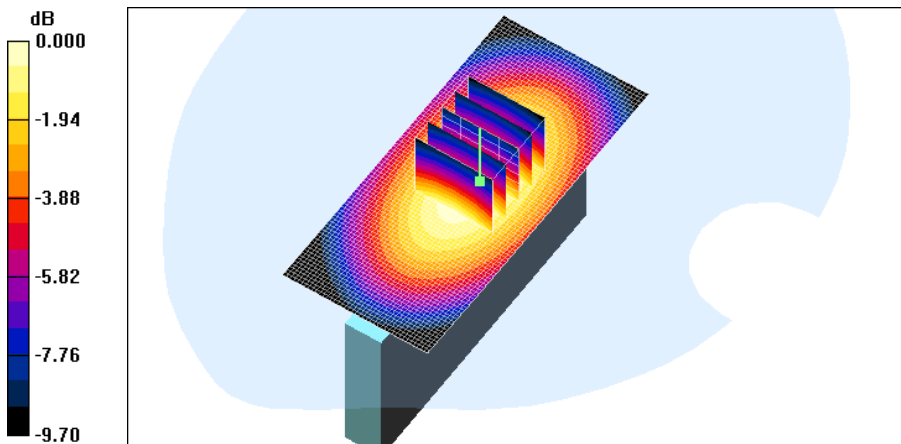

0 dB = 0.330mW/g

Test Laboratory: HCT CO., LTD
EUT Type: CDMA/LTE Phone with Bluetooth & WLAN
Liquid Temperature: 21.3 °C
Ambient Temperature: 21.5 °C
Test Date: Jun.08, 2011

DUT: ADR8995; Type: Bar; Serial: #1

Communication System: CDMA 835MHz FCC; Frequency: 836.52 MHz; Duty Cycle: 1:1
Medium parameters used (interpolated): $f = 836.52$ MHz; $\sigma = 0.982$ mho/m; $\epsilon_r = 56.8$; $\rho = 1000$ kg/m³
Phantom section: Flat Section ; Measurement SW: DASY4, V4.7 Build 71; Postprocessing SW: SEMCAD, V1.8 Build 184

DASY4 Configuration:

- Probe: ES3DV3 - SN3161; ConvF(5.86, 5.86, 5.86); Calibrated: 2011-03-17
- Sensor-Surface: 4mm (Mechanical Surface Detection)
- Electronics: DAE3 Sn466; Calibrated: 2011-03-01
- Phantom: 800/900 Phantom; Type: SAM

EVDO Body Top side 384/Area Scan (41x61x1): Measurement grid: dx=15mm, dy=15mm

[Info: Interpolated medium parameters used for SAR evaluation.](#)

Maximum value of SAR (interpolated) = 0.121 mW/g

EVDO Body Top side 384/Zoom Scan (5x5x7)/Cube 0: Measurement grid: dx=8mm, dy=8mm, dz=5mm

Reference Value = 10.8 V/m; Power Drift = 0.075 dB

Peak SAR (extrapolated) = 0.189 W/kg

SAR(1 g) = 0.108 mW/g; SAR(10 g) = 0.062 mW/g

[Info: Interpolated medium parameters used for SAR evaluation.](#)

Maximum value of SAR (measured) = 0.120 mW/g

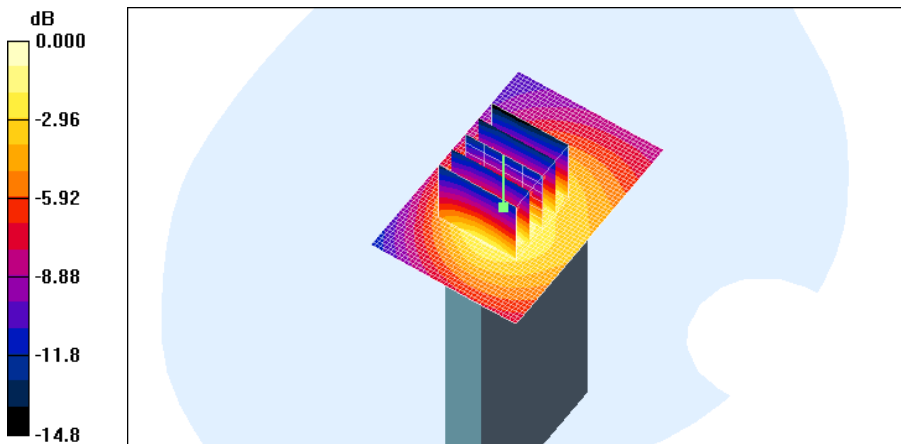

0 dB = 0.120mW/g

Test Laboratory: HCT CO., LTD
EUT Type: CDMA/LTE Phone with Bluetooth & WLAN
Liquid Temperature: 21.2 °C
Ambient Temperature: 21.4 °C
Test Date: Jun.09, 2011

DUT: ADR8995; Type: Bar; Serial: #1

Communication System: PCS 1900; Frequency: 1880 MHz; Duty Cycle: 1:1
Medium parameters used: $f = 1880$ MHz; $\sigma = 1.54$ mho/m; $\epsilon_r = 52$; $\rho = 1000$ kg/m³
Phantom section: Flat Section ; Measurement SW: DASY4, V4.7 Build 71; Postprocessing SW: SEMCAD, V1.8 Build 184

DASY4 Configuration:

- Probe: ES3DV3 - SN3161; ConvF(4.49, 4.49, 4.49); Calibrated: 2011-03-17
- Sensor-Surface: 4mm (Mechanical Surface Detection)
- Electronics: DAE3 Sn466; Calibrated: 2011-03-01
- Phantom: 1800/1900 Phantom; Type: SAM

PCS Front 600/Area Scan (51x101x1): Measurement grid: dx=15mm, dy=15mm
Maximum value of SAR (interpolated) = 0.482 mW/g

PCS Front 600/Zoom Scan (5x5x7)/Cube 0: Measurement grid: dx=8mm, dy=8mm, dz=5mm
Reference Value = 10.6 V/m; Power Drift = -0.072 dB
Peak SAR (extrapolated) = 0.725 W/kg
SAR(1 g) = 0.450 mW/g; SAR(10 g) = 0.274 mW/g
Maximum value of SAR (measured) = 0.491 mW/g

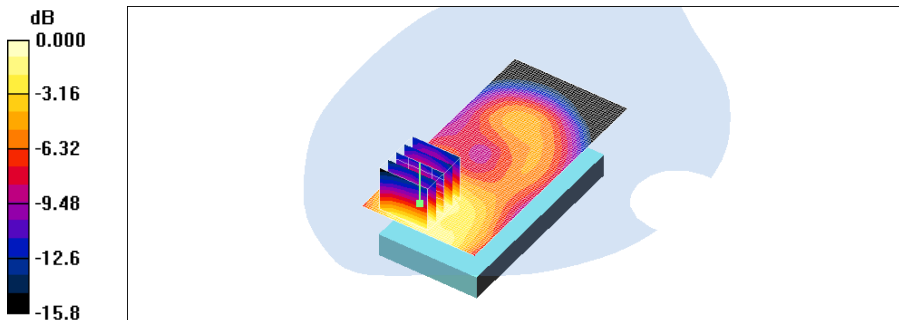

0 dB = 0.491mW/g

Test Laboratory: HCT CO., LTD
EUT Type: CDMA/LTE Phone with Bluetooth & WLAN
Liquid Temperature: 21.2 °C
Ambient Temperature: 21.4 °C
Test Date: Jun.09, 2011

DUT: ADR8995; Type: Bar; Serial: #1

Communication System: PCS 1900; Frequency: 1880 MHz; Duty Cycle: 1:1
Medium parameters used: $f = 1880$ MHz; $\sigma = 1.54$ mho/m; $\epsilon_r = 52$; $\rho = 1000$ kg/m³
Phantom section: Flat Section ; Measurement SW: DASY4, V4.7 Build 71; Postprocessing SW: SEMCAD, V1.8 Build 184

DASY4 Configuration:

- Probe: ES3DV3 - SN3161; ConvF(4.49, 4.49, 4.49); Calibrated: 2011-03-17
- Sensor-Surface: 4mm (Mechanical Surface Detection)
- Electronics: DAE3 Sn466; Calibrated: 2011-03-01
- Phantom: 1800/1900 Phantom; Type: SAM

PCS Rear/Area Scan (51x101x1): Measurement grid: dx=15mm, dy=15mm
Maximum value of SAR (interpolated) = 0.551 mW/g

PCS Rear/Zoom Scan (5x5x7)/Cube 0: Measurement grid: dx=8mm, dy=8mm, dz=5mm
Reference Value = 10.7 V/m; Power Drift = -0.027 dB
Peak SAR (extrapolated) = 0.829 W/kg
SAR(1 g) = 0.505 mW/g; SAR(10 g) = 0.307 mW/g
Maximum value of SAR (measured) = 0.537 mW/g

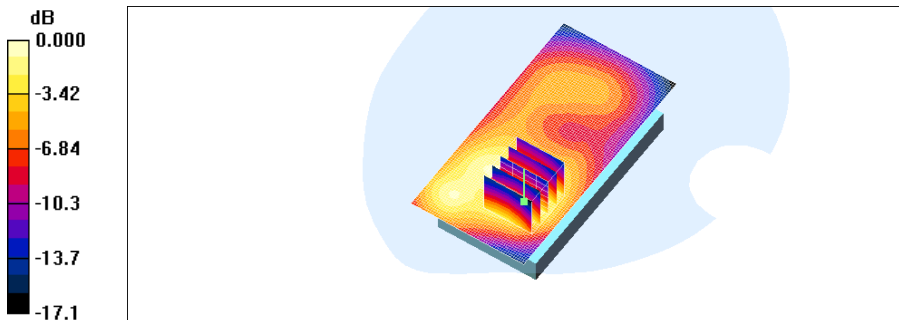

0 dB = 0.537mW/g

Test Laboratory: HCT CO., LTD
EUT Type: CDMA/LTE Phone with Bluetooth & WLAN
Liquid Temperature: 21.2 °C
Ambient Temperature: 21.4 °C
Test Date: Jun.09, 2011

DUT: ADR8995; Type: Bar; Serial: #1

Communication System: PCS 1900; Frequency: 1880 MHz; Duty Cycle: 1:1
Medium parameters used: $f = 1880$ MHz; $\sigma = 1.54$ mho/m; $\epsilon_r = 52$; $\rho = 1000$ kg/m³
Phantom section: Flat Section ; Measurement SW: DASY4, V4.7 Build 71; Postprocessing SW: SEMCAD, V1.8 Build 184

DASY4 Configuration:

- Probe: ES3DV3 - SN3161; ConvF(4.49, 4.49, 4.49); Calibrated: 2011-03-17
- Sensor-Surface: 4mm (Mechanical Surface Detection)
- Electronics: DAE3 Sn466; Calibrated: 2011-03-01
- Phantom: 1800/1900 Phantom; Type: SAM

PCS Left side 600/Area Scan (41x101x1): Measurement grid: dx=15mm, dy=15mm
Maximum value of SAR (interpolated) = 0.213 mW/g

PCS Left side 600/Zoom Scan (5x5x7)/Cube 0: Measurement grid: dx=8mm, dy=8mm, dz=5mm
Reference Value = 8.00 V/m; Power Drift = 0.054 dB
Peak SAR (extrapolated) = 0.307 W/kg
SAR(1 g) = 0.185 mW/g; SAR(10 g) = 0.108 mW/g
Maximum value of SAR (measured) = 0.200 mW/g

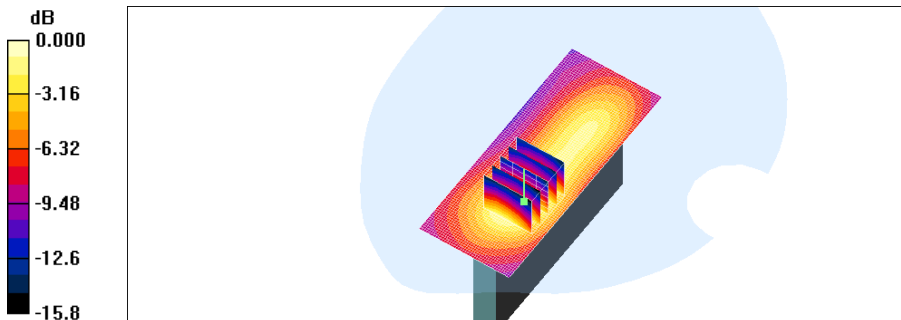

0 dB = 0.200mW/g

Test Laboratory: HCT CO., LTD
EUT Type: CDMA/LTE Phone with Bluetooth & WLAN
Liquid Temperature: 21.2 °C
Ambient Temperature: 21.4 °C
Test Date: Jun.09, 2011

DUT: ADR8995; Type: Bar; Serial: #1

Communication System: PCS 1900; Frequency: 1880 MHz; Duty Cycle: 1:1
Medium parameters used: $f = 1880$ MHz; $\sigma = 1.54$ mho/m; $\epsilon_r = 52$; $\rho = 1000$ kg/m³
Phantom section: Flat Section ; Measurement SW: DASY4, V4.7 Build 71; Postprocessing SW: SEMCAD, V1.8 Build 184

DASY4 Configuration:

- Probe: ES3DV3 - SN3161; ConvF(4.49, 4.49, 4.49); Calibrated: 2011-03-17
- Sensor-Surface: 4mm (Mechanical Surface Detection)
- Electronics: DAE3 Sn466; Calibrated: 2011-03-01
- Phantom: 1800/1900 Phantom; Type: SAM

PCS Right side 600/Area Scan (41x101x1): Measurement grid: dx=15mm, dy=15mm
Maximum value of SAR (interpolated) = 0.172 mW/g

PCS Right side 600/Zoom Scan (5x5x7)/Cube 0: Measurement grid: dx=8mm, dy=8mm, dz=5mm
Reference Value = 8.92 V/m; Power Drift = 0.103 dB
Peak SAR (extrapolated) = 0.263 W/kg
SAR(1 g) = 0.159 mW/g; SAR(10 g) = 0.094 mW/g
Maximum value of SAR (measured) = 0.174 mW/g

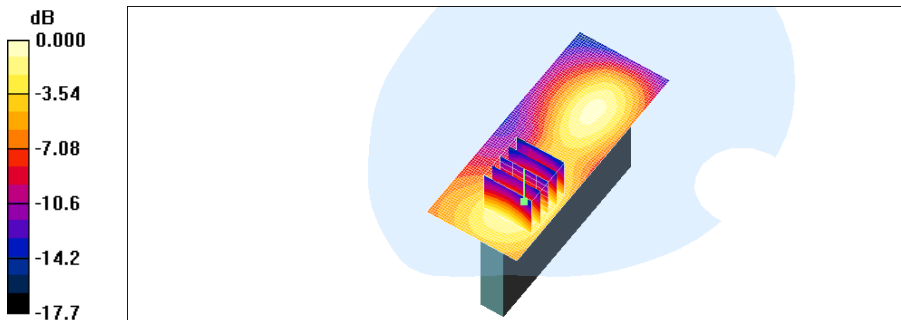

0 dB = 0.174mW/g

Test Laboratory: HCT CO., LTD
EUT Type: CDMA/LTE Phone with Bluetooth & WLAN
Liquid Temperature: 21.2 °C
Ambient Temperature: 21.4 °C
Test Date: Jun.09, 2011

DUT: ADR8995; Type: Bar; Serial: #1

Communication System: PCS 1900; Frequency: 1880 MHz; Duty Cycle: 1:1
Medium parameters used: $f = 1880$ MHz; $\sigma = 1.54$ mho/m; $\epsilon_r = 52$; $\rho = 1000$ kg/m³
Phantom section: Flat Section ; Measurement SW: DASY4, V4.7 Build 71; Postprocessing SW: SEMCAD, V1.8 Build 184

DASY4 Configuration:

- Probe: ES3DV3 - SN3161; ConvF(4.49, 4.49, 4.49); Calibrated: 2011-03-17
- Sensor-Surface: 4mm (Mechanical Surface Detection)
- Electronics: DAE3 Sn466; Calibrated: 2011-03-01
- Phantom: 1800/1900 Phantom; Type: SAM

PCS Bottom side 600/Area Scan (41x61x1): Measurement grid: dx=15mm, dy=15mm
Maximum value of SAR (interpolated) = 0.637 mW/g

PCS Bottom side 600/Zoom Scan (5x5x7)/Cube 0: Measurement grid: dx=8mm, dy=8mm, dz=5mm
Reference Value = 18.5 V/m; Power Drift = -0.006 dB
Peak SAR (extrapolated) = 0.926 W/kg
SAR(1 g) = 0.550 mW/g; SAR(10 g) = 0.302 mW/g
Maximum value of SAR (measured) = 0.624 mW/g

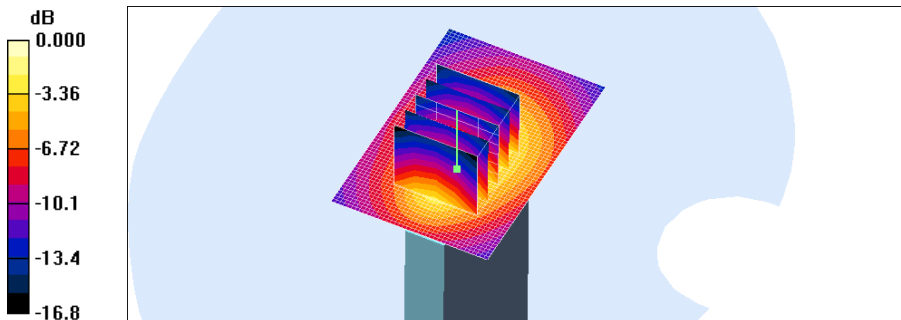

0 dB = 0.624mW/g

Test Laboratory: HCT CO., LTD
EUT Type: CDMA/LTE Phone with Bluetooth & WLAN
Liquid Temperature: 21.2 °C
Ambient Temperature: 21.4 °C
Test Date: Jun.09, 2011

DUT: ADR8995; Type: Bar; Serial: #1

Communication System: PCS 1900; Frequency: 1880 MHz; Duty Cycle: 1:1
Medium parameters used: $f = 1880$ MHz; $\sigma = 1.54$ mho/m; $\epsilon_r = 52$; $\rho = 1000$ kg/m³
Phantom section: Flat Section ; Measurement SW: DASY4, V4.7 Build 71; Postprocessing SW: SEMCAD, V1.8 Build 184

DASY4 Configuration:

- Probe: ES3DV3 - SN3161; ConvF(4.49, 4.49, 4.49); Calibrated: 2011-03-17
- Sensor-Surface: 4mm (Mechanical Surface Detection)
- Electronics: DAE3 Sn466; Calibrated: 2011-03-01
- Phantom: 1800/1900 Phantom; Type: SAM

PCS EVDO front 600/Area Scan (51x101x1): Measurement grid: dx=15mm, dy=15mm
Maximum value of SAR (interpolated) = 0.321 mW/g

PCS EVDO front 600/Zoom Scan (5x5x7)/Cube 0: Measurement grid: dx=8mm, dy=8mm, dz=5mm
Reference Value = 12.6 V/m; Power Drift = 0.030 dB
Peak SAR (extrapolated) = 0.470 W/kg
SAR(1 g) = 0.295 mW/g; SAR(10 g) = 0.178 mW/g
Maximum value of SAR (measured) = 0.322 mW/g

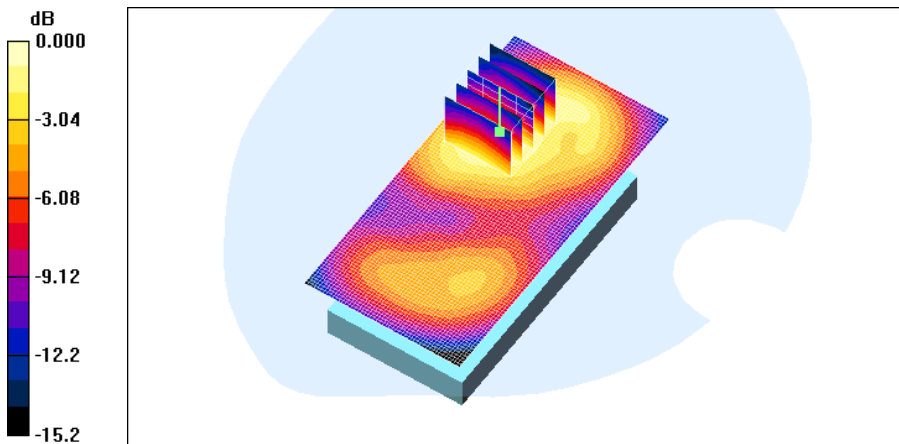

0 dB = 0.322mW/g

Test Laboratory: HCT CO., LTD
EUT Type: CDMA/LTE Phone with Bluetooth & WLAN
Liquid Temperature: 21.2 °C
Ambient Temperature: 21.4 °C
Test Date: Jun.09, 2011

DUT: ADR8995; Type: Bar; Serial: #1

Communication System: PCS 1900; Frequency: 1880 MHz; Duty Cycle: 1:1
Medium parameters used: $f = 1880$ MHz; $\sigma = 1.54$ mho/m; $\epsilon_r = 52$; $\rho = 1000$ kg/m³
Phantom section: Flat Section ; Measurement SW: DASY4, V4.7 Build 71; Postprocessing SW: SEMCAD, V1.8 Build 184

DASY4 Configuration:

- Probe: ES3DV3 - SN3161; ConvF(4.49, 4.49, 4.49); Calibrated: 2011-03-17
- Sensor-Surface: 4mm (Mechanical Surface Detection)
- Electronics: DAE3 Sn466; Calibrated: 2011-03-01
- Phantom: 1800/1900 Phantom; Type: SAM

PCS EVDO Rear 600/Area Scan (51x101x1): Measurement grid: dx=15mm, dy=15mm
Maximum value of SAR (interpolated) = 0.907 mW/g

PCS EVDO Rear 600/Zoom Scan (5x5x7)/Cube 0: Measurement grid: dx=8mm, dy=8mm, dz=5mm
Reference Value = 22.5 V/m; Power Drift = -0.069 dB
Peak SAR (extrapolated) = 1.37 W/kg
SAR(1 g) = 0.797 mW/g; SAR(10 g) = 0.460 mW/g
Maximum value of SAR (measured) = 0.865 mW/g

PCS EVDO Rear 600/Zoom Scan (5x5x7)/Cube 1: Measurement grid: dx=8mm, dy=8mm, dz=5mm
Reference Value = 22.5 V/m; Power Drift = -0.069 dB
Peak SAR (extrapolated) = 1.07 W/kg
SAR(1 g) = 0.587 mW/g; SAR(10 g) = 0.350 mW/g
Maximum value of SAR (measured) = 0.662 mW/g

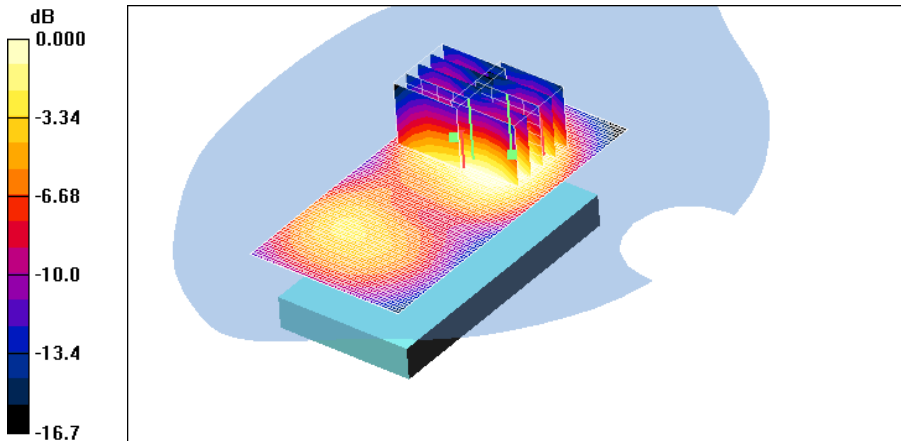

0 dB = 0.662mW/g

Test Laboratory: HCT CO., LTD
EUT Type: CDMA/LTE Phone with Bluetooth & WLAN
Liquid Temperature: 21.2 °C
Ambient Temperature: 21.4 °C
Test Date: Jun.09, 2011

DUT: ADR8995; Type: Bar; Serial: #1

Communication System: PCS 1900; Frequency: 1880 MHz; Duty Cycle: 1:1
Medium parameters used: $f = 1880$ MHz; $\sigma = 1.54$ mho/m; $\epsilon_r = 52$; $\rho = 1000$ kg/m³
Phantom section: Flat Section ; Measurement SW: DASY4, V4.7 Build 71; Postprocessing SW: SEMCAD, V1.8 Build 184

DASY4 Configuration:

- Probe: ES3DV3 - SN3161; ConvF(4.49, 4.49, 4.49); Calibrated: 2011-03-17
- Sensor-Surface: 4mm (Mechanical Surface Detection)
- Electronics: DAE3 Sn466; Calibrated: 2011-03-01
- Phantom: 1800/1900 Phantom; Type: SAM

PCS EVDO Left side 600/Area Scan (41x101x1): Measurement grid: dx=15mm, dy=15mm
Maximum value of SAR (interpolated) = 0.122 mW/g

PCS EVDO Left side 600/Zoom Scan (5x5x7)/Cube 0: Measurement grid: dx=8mm, dy=8mm, dz=5mm
Reference Value = 8.89 V/m; Power Drift = 0.022 dB
Peak SAR (extrapolated) = 0.183 W/kg
SAR(1 g) = 0.111 mW/g; SAR(10 g) = 0.066 mW/g
Maximum value of SAR (measured) = 0.122 mW/g

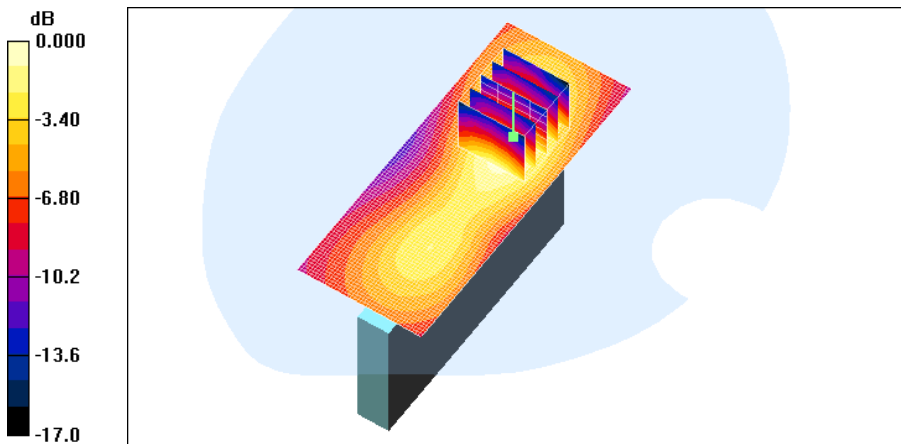

0 dB = 0.122mW/g

Test Laboratory: HCT CO., LTD
EUT Type: CDMA/LTE Phone with Bluetooth & WLAN
Liquid Temperature: 21.2 °C
Ambient Temperature: 21.4 °C
Test Date: Jun.09, 2011

DUT: ADR8995; Type: Bar; Serial: #1

Communication System: PCS 1900; Frequency: 1880 MHz; Duty Cycle: 1:1
Medium parameters used: $f = 1880$ MHz; $\sigma = 1.54$ mho/m; $\epsilon_r = 52$; $\rho = 1000$ kg/m³
Phantom section: Flat Section ; Measurement SW: DASY4, V4.7 Build 71; Postprocessing SW: SEMCAD, V1.8 Build 184

DASY4 Configuration:

- Probe: ES3DV3 - SN3161; ConvF(4.49, 4.49, 4.49); Calibrated: 2011-03-17
- Sensor-Surface: 4mm (Mechanical Surface Detection)
- Electronics: DAE3 Sn466; Calibrated: 2011-03-01
- Phantom: 1800/1900 Phantom; Type: SAM

PCS EVDO Right side 600/Area Scan (41x101x1): Measurement grid: dx=15mm, dy=15mm
Maximum value of SAR (interpolated) = 0.183 mW/g

PCS EVDO Right side 600/Zoom Scan (5x5x7)/Cube 0: Measurement grid: dx=8mm, dy=8mm, dz=5mm
Reference Value = 4.69 V/m; Power Drift = 0.08 dB
Peak SAR (extrapolated) = 0.281 W/kg
SAR(1 g) = 0.172 mW/g; SAR(10 g) = 0.100 mW/g
Maximum value of SAR (measured) = 0.190 mW/g

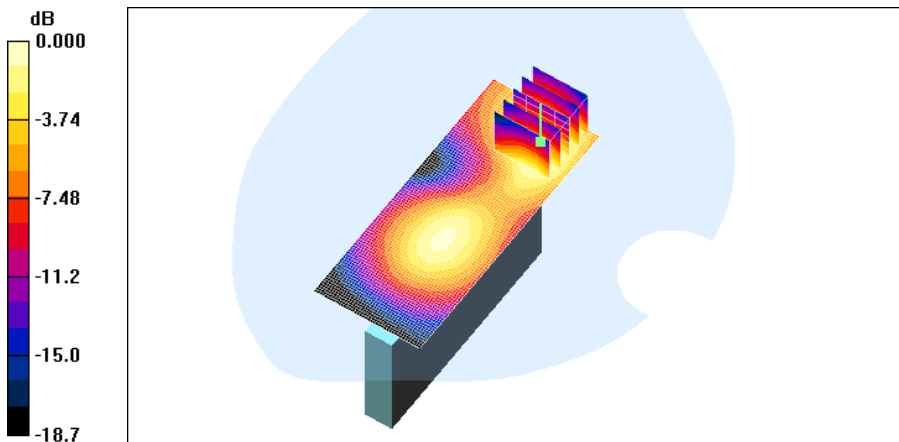

0 dB = 0.190mW/g

Test Laboratory: HCT CO., LTD
EUT Type: CDMA/LTE Phone with Bluetooth & WLAN
Liquid Temperature: 21.2 °C
Ambient Temperature: 21.4 °C
Test Date: Jun.09, 2011

DUT: ADR8995; Type: Bar; Serial: #1

Communication System: PCS 1900; Frequency: 1880 MHz; Duty Cycle: 1:1
Medium parameters used: $f = 1880$ MHz; $\sigma = 1.54$ mho/m; $\epsilon_r = 52$; $\rho = 1000$ kg/m³
Phantom section: Flat Section ; Measurement SW: DASY4, V4.7 Build 71; Postprocessing SW: SEMCAD, V1.8 Build 184

DASY4 Configuration:

- Probe: ES3DV3 - SN3161; ConvF(4.49, 4.49, 4.49); Calibrated: 2011-03-17
- Sensor-Surface: 4mm (Mechanical Surface Detection)
- Electronics: DAE3 Sn466; Calibrated: 2011-03-01
- Phantom: 1800/1900 Phantom; Type: SAM

PCS EVDO Top side 600/Area Scan (41x61x1): Measurement grid: dx=15mm, dy=15mm
Maximum value of SAR (interpolated) = 0.566 mW/g

PCS EVDO Top side 600/Zoom Scan (5x5x7)/Cube 0: Measurement grid: dx=8mm, dy=8mm, dz=5mm
Reference Value = 19.7 V/m; Power Drift = -0.099 dB
Peak SAR (extrapolated) = 0.910 W/kg
SAR(1 g) = 0.526 mW/g; SAR(10 g) = 0.277 mW/g
Maximum value of SAR (measured) = 0.562 mW/g

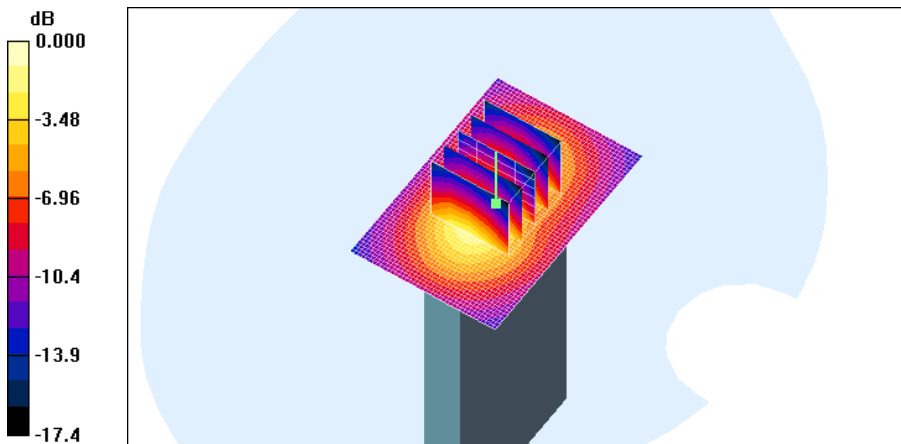

0 dB = 0.562mW/g

Test Laboratory: HCT CO., LTD
EUT Type: CDMA/LTE Phone with Bluetooth & WLAN
Liquid Temperature: 21.2 °C
Ambient Temperature: 21.4 °C
Test Date: Jun.10, 2011

DUT: ADR8995; Type: Bar; Serial: #1

Communication System: 2450MHz FCC; Frequency: 2437 MHz; Duty Cycle: 1:1
Medium parameters used (interpolated): $f = 2437$ MHz; $\sigma = 1.94$ mho/m; $\epsilon_r = 51.6$; $\rho = 1000$ kg/m³
Phantom section: Flat Section ; Measurement SW: DASY4, V4.7 Build 71; Postprocessing SW: SEMCAD, V1.8 Build 184

DASY4 Configuration:

- Probe: ES3DV3 - SN3161; ConvF(4.03, 4.03, 4.03); Calibrated: 2011-03-17
- Sensor-Surface: 4mm (Mechanical Surface Detection)
- Electronics: DAE3 Sn446; Calibrated: 2010-09-21
- Phantom: 1800/1900 Phantom; Type: SAM

802.11b Front 6ch/Area Scan (61x91x1): Measurement grid: dx=15mm, dy=15mm

[Info: Interpolated medium parameters used for SAR evaluation.](#)

Maximum value of SAR (interpolated) = 0.083 mW/g

802.11b Front 6ch/Zoom Scan (5x5x7)/Cube 0: Measurement grid: dx=8mm, dy=8mm, dz=5mm

Reference Value = 1.30 V/m; Power Drift = 0.07 dB

Peak SAR (extrapolated) = 0.044 W/kg

SAR(1 g) = 0.00145 mW/g; SAR(10 g) = 0.000446 mW/g

[Info: Interpolated medium parameters used for SAR evaluation.](#)

Maximum value of SAR (measured) = 0.044 mW/g

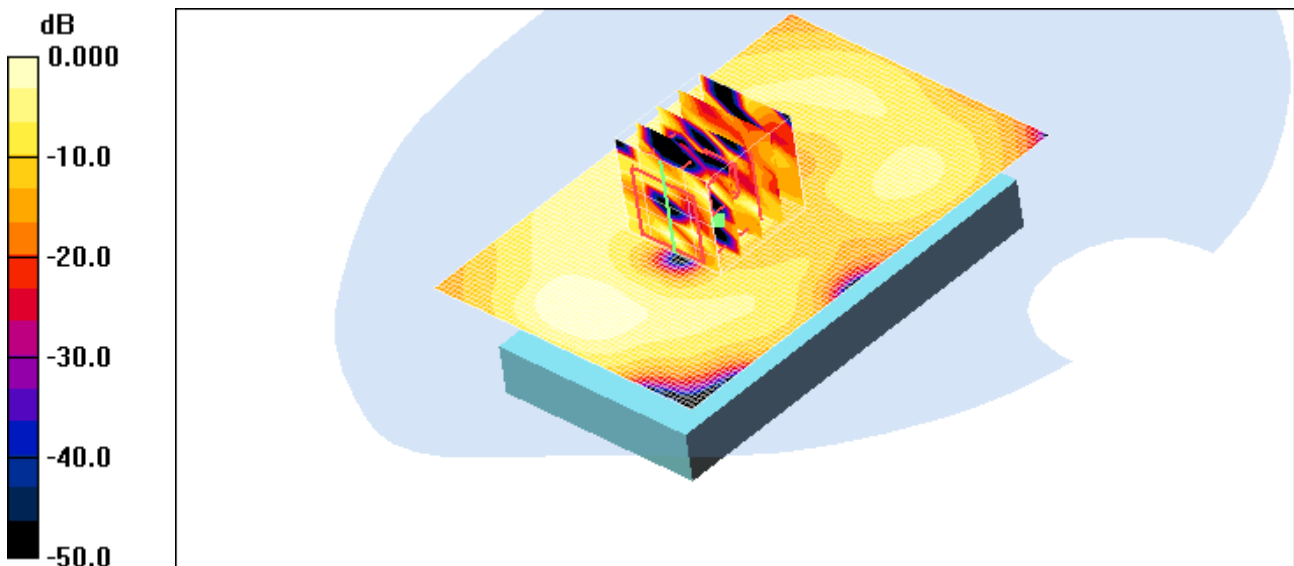

0 dB = 0.044mW/g

Test Laboratory: HCT CO., LTD
EUT Type: CDMA/LTE Phone with Bluetooth & WLAN
Liquid Temperature: 21.2 °C
Ambient Temperature: 21.4 °C
Test Date: Jun.10, 2011

DUT: ADR8995; Type: Bar; Serial: #1

Communication System: 2450MHz FCC; Frequency: 2437 MHz;Duty Cycle: 1:1
Medium parameters used (interpolated): $f = 2437$ MHz; $\sigma = 1.94$ mho/m; $\epsilon_r = 51.6$; $\rho = 1000$ kg/m³
Phantom section: Flat Section ; Measurement SW: DASY4, V4.7 Build 71; Postprocessing SW: SEMCAD, V1.8 Build 184

DASY4 Configuration:

- Probe: ES3DV3 - SN3161; ConvF(4.03, 4.03, 4.03); Calibrated: 2011-03-17
- Sensor-Surface: 4mm (Mechanical Surface Detection)
- Electronics: DAE3 Sn466; Calibrated: 2011-03-01
- Phantom: 1800/1900 Phantom; Type: SAM

802.11b Rear 6ch/Area Scan (61x91x1): Measurement grid: dx=15mm, dy=15mm

[Info: Interpolated medium parameters used for SAR evaluation.](#)

Maximum value of SAR (interpolated) = 0.136 mW/g

802.11b Rear 6ch/Zoom Scan (5x5x7)/Cube 0: Measurement grid: dx=8mm, dy=8mm, dz=5mm

Reference Value = 2.44 V/m; Power Drift = 0.111 dB

Peak SAR (extrapolated) = 0.188 W/kg

SAR(1 g) = 0.088 mW/g; SAR(10 g) = 0.043 mW/g

[Info: Interpolated medium parameters used for SAR evaluation.](#)

Maximum value of SAR (measured) = 0.115 mW/g

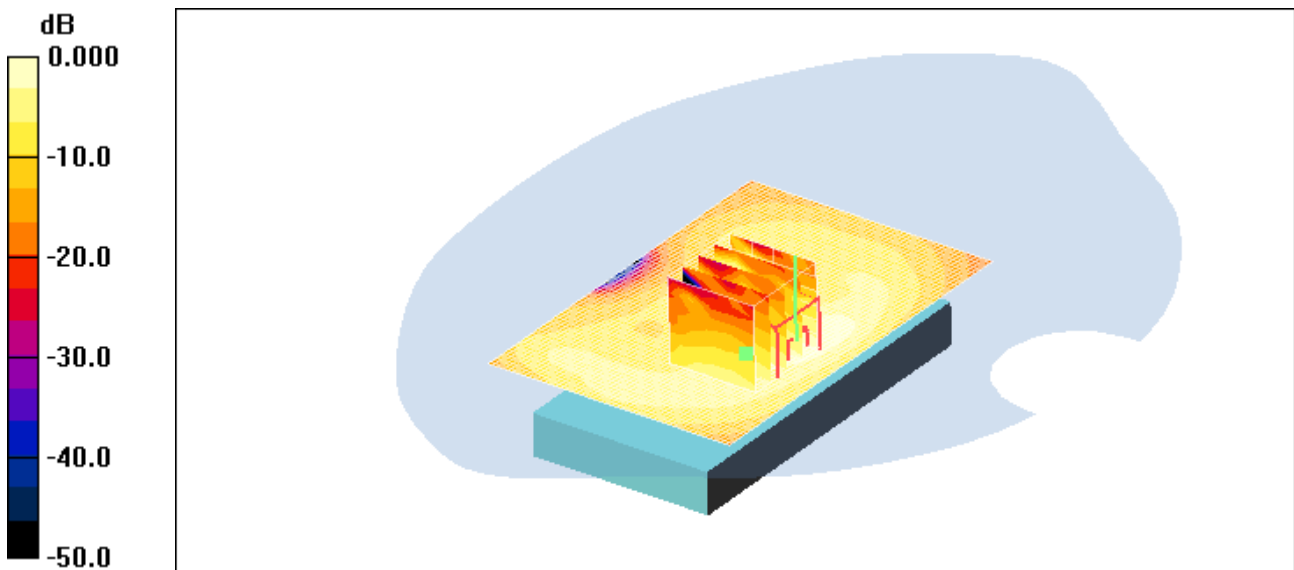

0 dB = 0.115mW/g

Test Laboratory: HCT CO., LTD
EUT Type: CDMA/LTE Phone with Bluetooth & WLAN
Liquid Temperature: 21.2 °C
Ambient Temperature: 21.4 °C
Test Date: Jun.10, 2011

DUT: ADR8995; Type: Bar; Serial: #1

Communication System: 2450MHz FCC; Frequency: 2437 MHz;Duty Cycle: 1:1
Medium parameters used (interpolated): $f = 2437$ MHz; $\sigma = 1.94$ mho/m; $\epsilon_r = 51.6$; $\rho = 1000$ kg/m³
Phantom section: Flat Section ; Measurement SW: DASY4, V4.7 Build 71; Postprocessing SW: SEMCAD, V1.8 Build 184

DASY4 Configuration:

- Probe: ES3DV3 - SN3161; ConvF(4.03, 4.03, 4.03); Calibrated: 2011-03-17
- Sensor-Surface: 4mm (Mechanical Surface Detection)
- Electronics: DAE3 Sn466; Calibrated: 2011-03-01
- Phantom: 1800/1900 Phantom; Type: SAM

802,11b Hotspot Left side 6ch/Area Scan (41x101x1): Measurement grid: dx=15mm, dy=15mm

[Info: Interpolated medium parameters used for SAR evaluation.](#)

Maximum value of SAR (interpolated) = 0.097 mW/g

802,11b Hotspot Left side 6ch/Zoom Scan (5x5x7)/Cube 0: Measurement grid: dx=8mm, dy=8mm, dz=5mm

Reference Value = 7.01 V/m; Power Drift = -0.027 dB

Peak SAR (extrapolated) = 0.190 W/kg

SAR(1 g) = 0.089 mW/g; SAR(10 g) = 0.037 mW/g

[Info: Interpolated medium parameters used for SAR evaluation.](#)

Maximum value of SAR (measured) = 0.096 mW/g

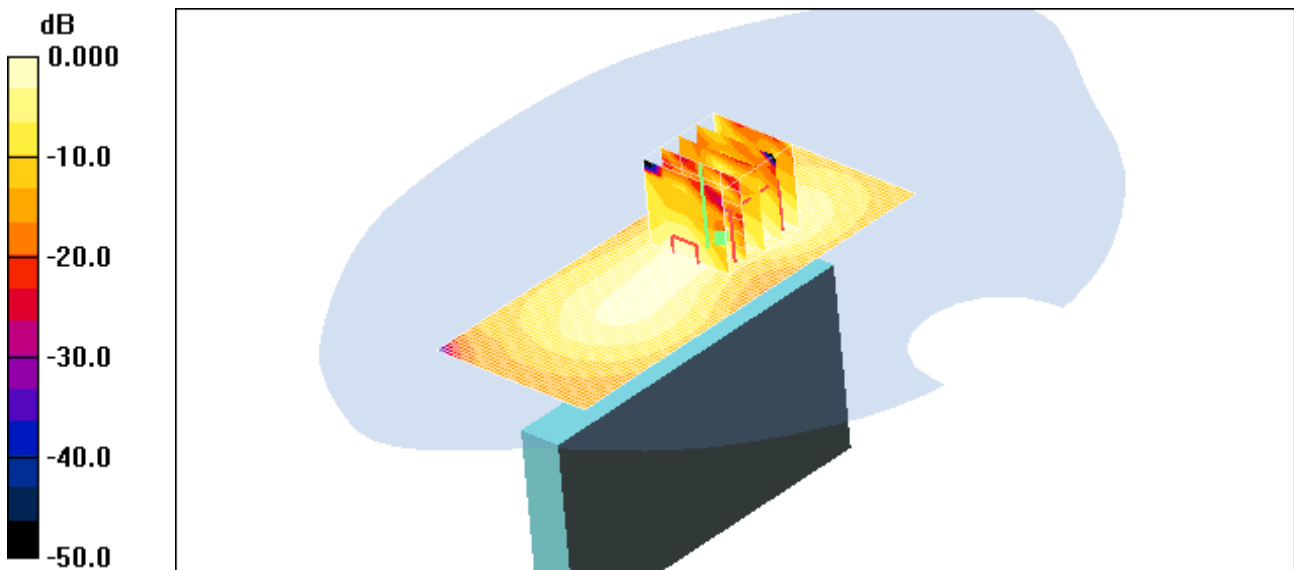

0 dB = 0.096mW/g

Test Laboratory: HCT CO., LTD
EUT Type: CDMA/LTE Phone with Bluetooth & WLAN
Liquid Temperature: 21.3 °C
Ambient Temperature: 21.5 °C
Test Date: May.09, 2011

DUT: ADR8995; Type: Bar; Serial: #1

Communication System: LTE; Frequency: 782 MHz; Duty Cycle: 1:1
Medium parameters used (interpolated): $f = 782$ MHz; $\sigma = 1$ mho/m; $\epsilon_r = 54.2$; $\rho = 1000$ kg/m³
Phantom section: Flat Section ; Measurement SW: DASY4, V4.7 Build 71; Postprocessing SW: SEMCAD, V1.8 Build 184

DASY4 Configuration:

- Probe: ES3DV3 - SN3161; ConvF(5.93, 5.93, 5.93); Calibrated: 2011-03-17
- Sensor-Surface: 4mm (Mechanical Surface Detection)
- Electronics: DAE3 Sn466; Calibrated: 2011-03-01
- Phantom: 800/900 Phantom; Type: SAM

LTE Body Front QPSK 1 0 23230/Area Scan (51x91x1): Measurement grid: dx=15mm, dy=15mm

[Info: Interpolated medium parameters used for SAR evaluation.](#)

Maximum value of SAR (interpolated) = 0.156 mW/g

LTE Body Front QPSK 1 0 23230/Zoom Scan (5x5x7)/Cube 0: Measurement grid: dx=8mm, dy=8mm, dz=5mm

Reference Value = 11.8 V/m; Power Drift = 0.017 dB

Peak SAR (extrapolated) = 0.184 W/kg

SAR(1 g) = 0.147 mW/g; SAR(10 g) = 0.111 mW/g

[Info: Interpolated medium parameters used for SAR evaluation.](#)

Maximum value of SAR (measured) = 0.154 mW/g

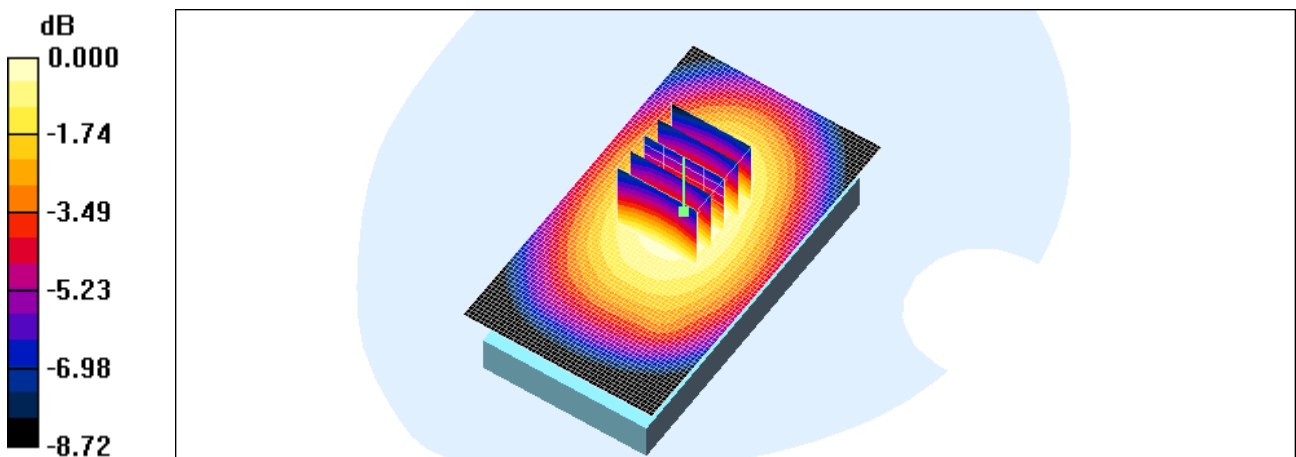

Test Laboratory: HCT CO., LTD
EUT Type: CDMA/LTE Phone with Bluetooth & WLAN
Liquid Temperature: 21.3 °C
Ambient Temperature: 21.5 °C
Test Date: May.09, 2011

DUT: ADR8995; Type: Bar; Serial: #1

Communication System: LTE; Frequency: 782 MHz; Duty Cycle: 1:1
Medium parameters used (interpolated): $f = 782 \text{ MHz}$; $\sigma = 1 \text{ mho/m}$; $\epsilon_r = 54.2$; $\rho = 1000 \text{ kg/m}^3$
Phantom section: Flat Section ; Measurement SW: DASY4, V4.7 Build 71; Postprocessing SW: SEMCAD, V1.8 Build 184

DASY4 Configuration:

- Probe: ES3DV3 - SN3161; ConvF(5.93, 5.93, 5.93); Calibrated: 2011-03-17
- Sensor-Surface: 4mm (Mechanical Surface Detection)
- Electronics: DAE3 Sn466; Calibrated: 2011-03-01
- Phantom: 800/900 Phantom; Type: SAM

LTE Body Front QPSK 1 49 23230/Area Scan (51x91x1): Measurement grid: dx=15mm, dy=15mm

[Info: Interpolated medium parameters used for SAR evaluation.](#)

Maximum value of SAR (interpolated) = 0.174 mW/g

LTE Body Front QPSK 1 49 23230/Zoom Scan (5x5x7)/Cube 0: Measurement grid: dx=8mm, dy=8mm, dz=5mm

Reference Value = 12.6 V/m; Power Drift = 0.018 dB

Peak SAR (extrapolated) = 0.208 W/kg

SAR(1 g) = 0.166 mW/g; SAR(10 g) = 0.125 mW/g

[Info: Interpolated medium parameters used for SAR evaluation.](#)

Maximum value of SAR (measured) = 0.174 mW/g

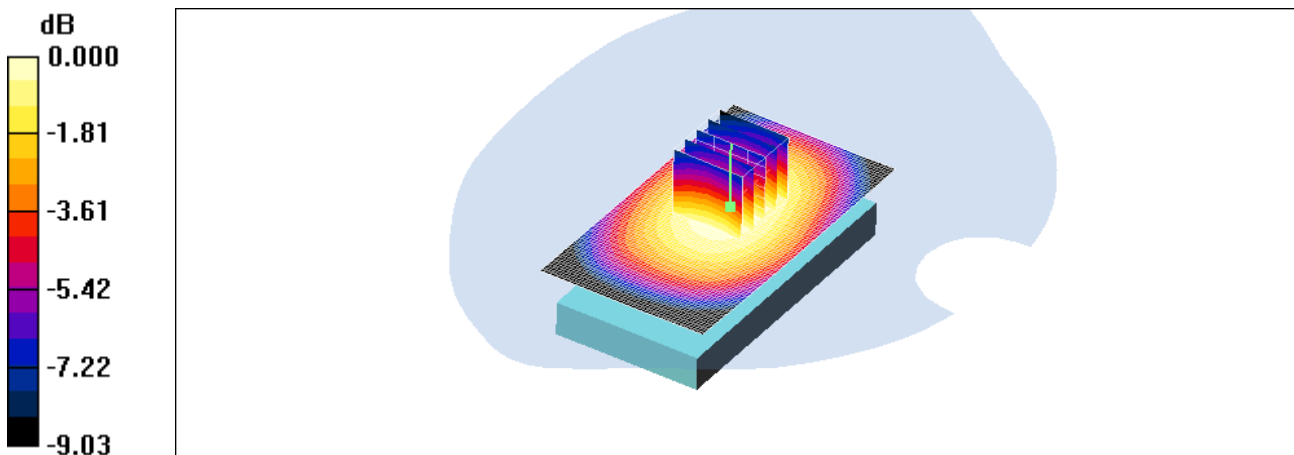

0 dB = 0.174mW/g

Test Laboratory: HCT CO., LTD
EUT Type: CDMA/LTE Phone with Bluetooth & WLAN
Liquid Temperature: 21.3 °C
Ambient Temperature: 21.5 °C
Test Date: May.09, 2011

DUT: ADR8995; Type: Bar; Serial: #1

Communication System: LTE; Frequency: 782 MHz; Duty Cycle: 1:1
Medium parameters used (interpolated): $f = 782 \text{ MHz}$; $\sigma = 1 \text{ mho/m}$; $\epsilon_r = 54.2$; $\rho = 1000 \text{ kg/m}^3$
Phantom section: Flat Section ; Measurement SW: DASY4, V4.7 Build 71; Postprocessing SW: SEMCAD, V1.8 Build 184

DASY4 Configuration:

- Probe: ES3DV3 - SN3161; ConvF(5.93, 5.93, 5.93); Calibrated: 2011-03-17
- Sensor-Surface: 4mm (Mechanical Surface Detection)
- Electronics: DAE3 Sn466; Calibrated: 2011-03-01
- Phantom: 800/900 Phantom; Type: SAM

LTE Body Front QPSK 25 13 23230/Area Scan (51x91x1): Measurement grid: dx=15mm, dy=15mm

[Info: Interpolated medium parameters used for SAR evaluation.](#)

Maximum value of SAR (interpolated) = 0.126 mW/g

LTE Body Front QPSK 25 13 23230/Zoom Scan (5x5x7)/Cube 0: Measurement grid: dx=8mm, dy=8mm, dz=5mm

Reference Value = 10.7 V/m; Power Drift = 0.009 dB

Peak SAR (extrapolated) = 0.149 W/kg

SAR(1 g) = 0.119 mW/g; SAR(10 g) = 0.090 mW/g

[Info: Interpolated medium parameters used for SAR evaluation.](#)

Maximum value of SAR (measured) = 0.125 mW/g

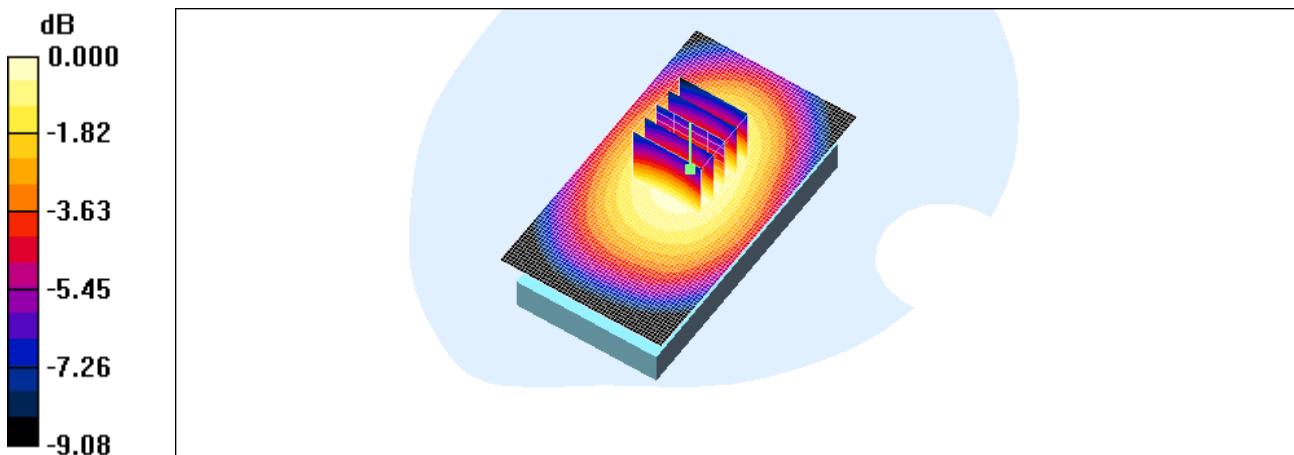

0 dB = 0.125mW/g

Test Laboratory: HCT CO., LTD
EUT Type: CDMA/LTE Phone with Bluetooth & WLAN
Liquid Temperature: 21.3 °C
Ambient Temperature: 21.5 °C
Test Date: May.09, 2011

DUT: ADR8995; Type: Bar; Serial: #1

Communication System: LTE; Frequency: 782 MHz; Duty Cycle: 1:1
Medium parameters used (interpolated): $f = 782$ MHz; $\sigma = 1$ mho/m; $\epsilon_r = 54.2$; $\rho = 1000$ kg/m³
Phantom section: Flat Section ; Measurement SW: DASY4, V4.7 Build 71; Postprocessing SW: SEMCAD, V1.8 Build 184

DASY4 Configuration:

- Probe: ES3DV3 - SN3161; ConvF(5.93, 5.93, 5.93); Calibrated: 2011-03-17
- Sensor-Surface: 4mm (Mechanical Surface Detection)
- Electronics: DAE3 Sn466; Calibrated: 2011-03-01
- Phantom: 800/900 Phantom; Type: SAM

LTE Body Rear QPSK 1 0 23230/Area Scan (51x91x1): Measurement grid: dx=15mm, dy=15mm

[Info: Interpolated medium parameters used for SAR evaluation.](#)

Maximum value of SAR (interpolated) = 0.460 mW/g

LTE Body Rear QPSK 1 0 23230/Zoom Scan (5x5x7)/Cube 0: Measurement grid: dx=8mm, dy=8mm, dz=5mm

Reference Value = 19.0 V/m; Power Drift = -0.033 dB

Peak SAR (extrapolated) = 0.544 W/kg

SAR(1 g) = 0.428 mW/g; SAR(10 g) = 0.317 mW/g

[Info: Interpolated medium parameters used for SAR evaluation.](#)

Maximum value of SAR (measured) = 0.451 mW/g

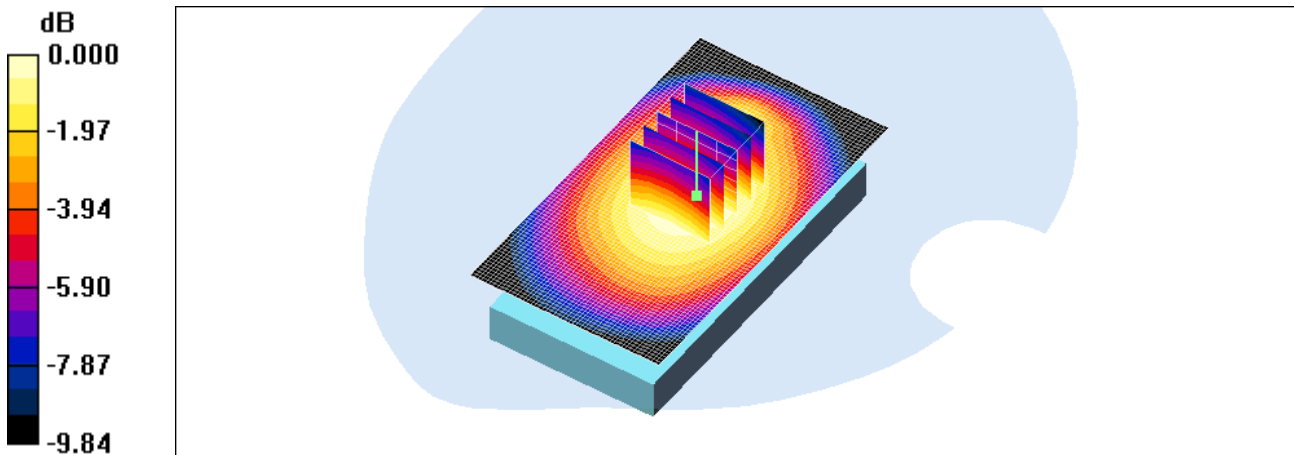

0 dB = 0.451mW/g

Test Laboratory: HCT CO., LTD
EUT Type: CDMA/LTE Phone with Bluetooth & WLAN
Liquid Temperature: 21.3 °C
Ambient Temperature: 21.5 °C
Test Date: May.09, 2011

DUT: ADR8995; Type: Bar; Serial: #1

Communication System: LTE; Frequency: 782 MHz; Duty Cycle: 1:1
Medium parameters used (interpolated): $f = 782 \text{ MHz}$; $\sigma = 1 \text{ mho/m}$; $\epsilon_r = 54.2$; $\rho = 1000 \text{ kg/m}^3$
Phantom section: Flat Section ; Measurement SW: DASY4, V4.7 Build 71; Postprocessing SW: SEMCAD, V1.8 Build 184

DASY4 Configuration:

- Probe: ES3DV3 - SN3161; ConvF(5.93, 5.93, 5.93); Calibrated: 2011-03-17
- Sensor-Surface: 4mm (Mechanical Surface Detection)
- Electronics: DAE3 Sn466; Calibrated: 2011-03-01
- Phantom: 800/900 Phantom; Type: SAM

LTE Body Rear QPSK 1 49 23230/Area Scan (51x91x1): Measurement grid: $dx=15\text{mm}$, $dy=15\text{mm}$

[Info: Interpolated medium parameters used for SAR evaluation.](#)

Maximum value of SAR (interpolated) = 0.471 mW/g

LTE Body Rear QPSK 1 49 23230/Zoom Scan (5x5x7)/Cube 0: Measurement grid: $dx=8\text{mm}$, $dy=8\text{mm}$, $dz=5\text{mm}$

Reference Value = 19.4 V/m; Power Drift = -0.046 dB

Peak SAR (extrapolated) = 0.565 W/kg

SAR(1 g) = 0.442 mW/g; SAR(10 g) = 0.326 mW/g

[Info: Interpolated medium parameters used for SAR evaluation.](#)

Maximum value of SAR (measured) = 0.467 mW/g

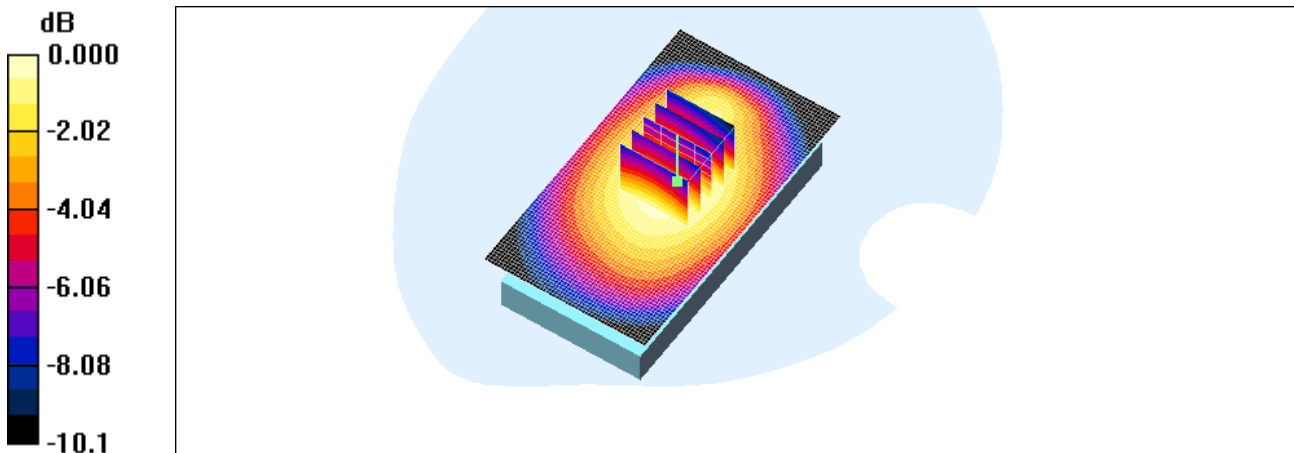

0 dB = 0.467mW/g

Test Laboratory: HCT CO., LTD
EUT Type: CDMA/LTE Phone with Bluetooth & WLAN
Liquid Temperature: 21.3 °C
Ambient Temperature: 21.5 °C
Test Date: May.09, 2011

DUT: ADR8995; Type: Bar; Serial: #1

Communication System: LTE; Frequency: 782 MHz; Duty Cycle: 1:1
Medium parameters used (interpolated): $f = 782 \text{ MHz}$; $\sigma = 1 \text{ mho/m}$; $\epsilon_r = 54.2$; $\rho = 1000 \text{ kg/m}^3$
Phantom section: Flat Section ; Measurement SW: DASY4, V4.7 Build 71; Postprocessing SW: SEMCAD, V1.8 Build 184

DASY4 Configuration:

- Probe: ES3DV3 - SN3161; ConvF(5.93, 5.93, 5.93); Calibrated: 2011-03-17
- Sensor-Surface: 4mm (Mechanical Surface Detection)
- Electronics: DAE3 Sn466; Calibrated: 2011-03-01
- Phantom: 800/900 Phantom; Type: SAM

LTE Body QPSK 25 13 23230/Area Scan (51x91x1): Measurement grid: $dx=15\text{mm}$, $dy=15\text{mm}$

[Info: Interpolated medium parameters used for SAR evaluation.](#)

Maximum value of SAR (interpolated) = 0.356 mW/g

LTE Body QPSK 25 13 23230/Zoom Scan (5x5x7)/Cube 0: Measurement grid: $dx=8\text{mm}$, $dy=8\text{mm}$, $dz=5\text{mm}$

Reference Value = 16.8 V/m; Power Drift = 0.006 dB

Peak SAR (extrapolated) = 0.427 W/kg

SAR(1 g) = 0.335 mW/g; SAR(10 g) = 0.248 mW/g

[Info: Interpolated medium parameters used for SAR evaluation.](#)

Maximum value of SAR (measured) = 0.353 mW/g

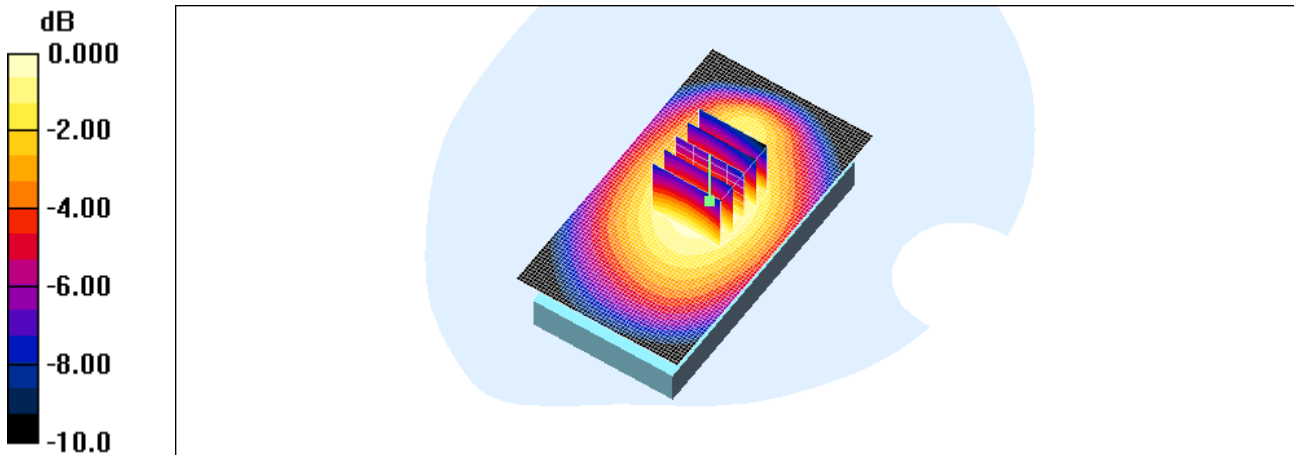

0 dB = 0.353mW/g

Test Laboratory: HCT CO., LTD
EUT Type: CDMA/LTE Phone with Bluetooth & WLAN
Liquid Temperature: 21.3 °C
Ambient Temperature: 21.5 °C
Test Date: May.09, 2011

DUT: ADR8995; Type: Bar; Serial: #1

Communication System: LTE; Frequency: 782 MHz; Duty Cycle: 1:1
Medium parameters used (interpolated): $f = 782 \text{ MHz}$; $\sigma = 1 \text{ mho/m}$; $\epsilon_r = 54.2$; $\rho = 1000 \text{ kg/m}^3$
Phantom section: Flat Section ; Measurement SW: DASY4, V4.7 Build 71; Postprocessing SW: SEMCAD, V1.8 Build 184

DASY4 Configuration:

- Probe: ES3DV3 - SN3161; ConvF(5.93, 5.93, 5.93); Calibrated: 2011-03-17
- Sensor-Surface: 4mm (Mechanical Surface Detection)
- Electronics: DAE3 Sn466; Calibrated: 2011-03-01
- Phantom: 800/900 Phantom; Type: SAM

LTE Body Left side QPSK 1 0 23230/Area Scan (41x91x1): Measurement grid: dx=15mm, dy=15mm

[Info: Interpolated medium parameters used for SAR evaluation.](#)

Maximum value of SAR (interpolated) = 0.147 mW/g

LTE Body Left side QPSK 1 0 23230/Zoom Scan (5x5x7)/Cube 0: Measurement grid: dx=8mm, dy=8mm, dz=5mm

Reference Value = 10.2 V/m; Power Drift = 0.056 dB

Peak SAR (extrapolated) = 0.190 W/kg

SAR(1 g) = 0.139 mW/g; SAR(10 g) = 0.097 mW/g

[Info: Interpolated medium parameters used for SAR evaluation.](#)

Maximum value of SAR (measured) = 0.149 mW/g

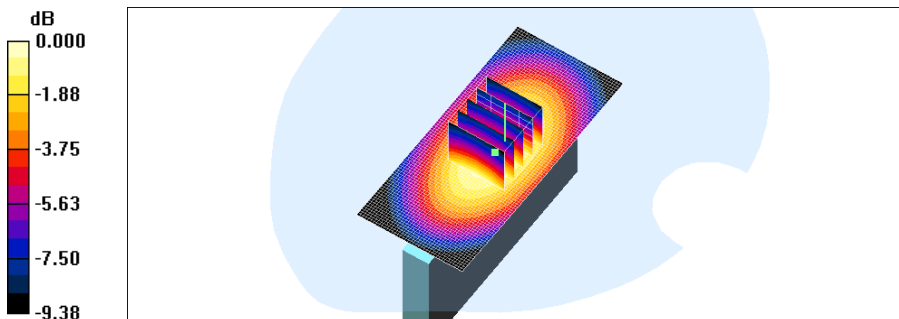

Test Laboratory: HCT CO., LTD
EUT Type: CDMA/LTE Phone with Bluetooth & WLAN
Liquid Temperature: 21.3 °C
Ambient Temperature: 21.5 °C
Test Date: May.09, 2011

DUT: ADR8995; Type: Bar; Serial: #1

Communication System: LTE; Frequency: 782 MHz; Duty Cycle: 1:1
Medium parameters used (interpolated): $f = 782$ MHz; $\sigma = 1$ mho/m; $\epsilon_r = 54.2$; $\rho = 1000$ kg/m³
Phantom section: Flat Section ; Measurement SW: DASY4, V4.7 Build 71; Postprocessing SW: SEMCAD, V1.8 Build 184

DASY4 Configuration:

- Probe: ES3DV3 - SN3161; ConvF(5.93, 5.93, 5.93); Calibrated: 2011-03-17
- Sensor-Surface: 4mm (Mechanical Surface Detection)
- Electronics: DAE3 Sn466; Calibrated: 2011-03-01
- Phantom: 800/900 Phantom; Type: SAM

LTE Body Left side QPSK 1 49 23230/Area Scan (41x91x1): Measurement grid: dx=15mm, dy=15mm

[Info: Interpolated medium parameters used for SAR evaluation.](#)

Maximum value of SAR (interpolated) = 0.181 mW/g

LTE Body Left side QPSK 1 49 23230/Zoom Scan (5x5x7)/Cube 0: Measurement grid: dx=8mm, dy=8mm, dz=5mm

Reference Value = 10.9 V/m; Power Drift = 0.009 dB

Peak SAR (extrapolated) = 0.220 W/kg

SAR(1 g) = 0.161 mW/g; SAR(10 g) = 0.113 mW/g

[Info: Interpolated medium parameters used for SAR evaluation.](#)

Maximum value of SAR (measured) = 0.171 mW/g

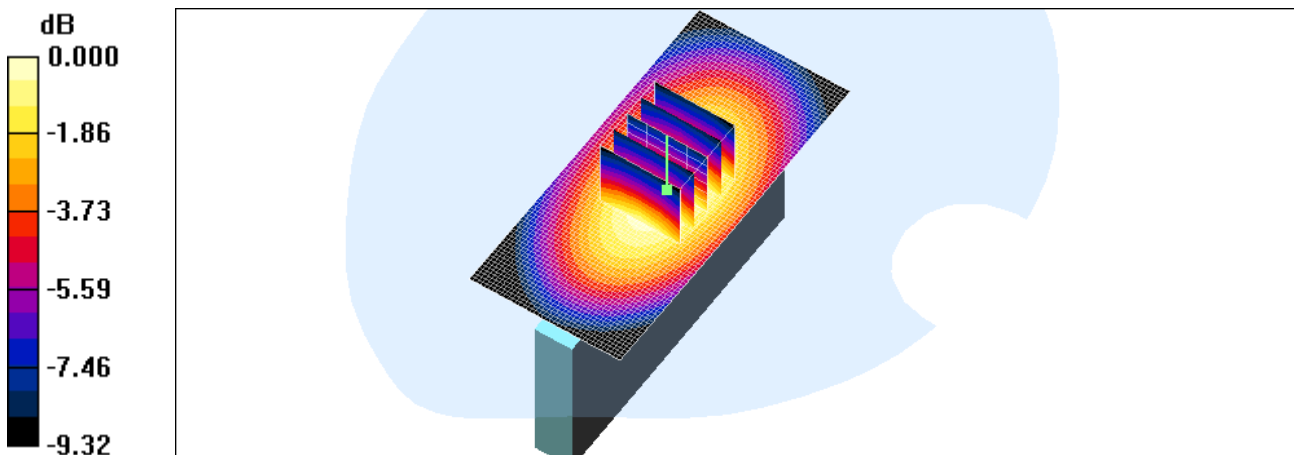

Test Laboratory: HCT CO., LTD
EUT Type: CDMA/LTE Phone with Bluetooth & WLAN
Liquid Temperature: 21.3 °C
Ambient Temperature: 21.5 °C
Test Date: May.09, 2011

DUT: ADR8995; Type: Bar; Serial: #1

Communication System: LTE; Frequency: 782 MHz; Duty Cycle: 1:1
Medium parameters used (interpolated): $f = 782 \text{ MHz}$; $\sigma = 1 \text{ mho/m}$; $\epsilon_r = 54.2$; $\rho = 1000 \text{ kg/m}^3$
Phantom section: Flat Section ; Measurement SW: DASY4, V4.7 Build 71; Postprocessing SW: SEMCAD, V1.8 Build 184

DASY4 Configuration:

- Probe: ES3DV3 - SN3161; ConvF(5.93, 5.93, 5.93); Calibrated: 2011-03-17
- Sensor-Surface: 4mm (Mechanical Surface Detection)
- Electronics: DAE3 Sn466; Calibrated: 2011-03-01
- Phantom: 800/900 Phantom; Type: SAM

LTE Body Left side QPSK 25 13 23230/Area Scan (41x91x1): Measurement grid: dx=15mm, dy=15mm

[Info: Interpolated medium parameters used for SAR evaluation.](#)

Maximum value of SAR (interpolated) = 0.123 mW/g

LTE Body Left side QPSK 25 13 23230/Zoom Scan (5x5x7)/Cube 0: Measurement grid: dx=8mm, dy=8mm, dz=5mm

Reference Value = 9.35 V/m; Power Drift = -0.054 dB

Peak SAR (extrapolated) = 0.161 W/kg

SAR(1 g) = 0.116 mW/g; SAR(10 g) = 0.080 mW/g

[Info: Interpolated medium parameters used for SAR evaluation.](#)

Maximum value of SAR (measured) = 0.123 mW/g

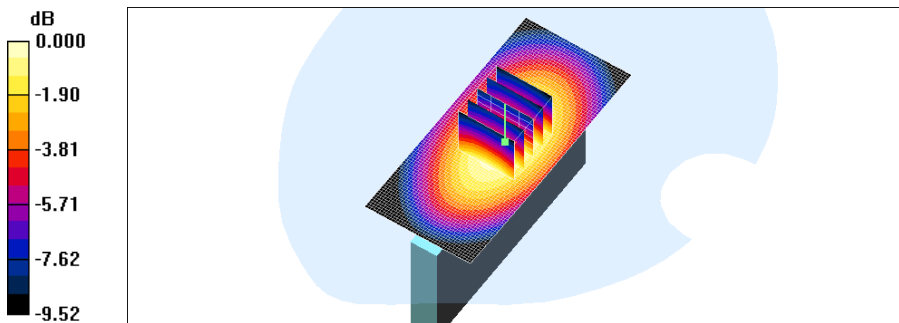

0 dB = 0.123mW/g

Test Laboratory: HCT CO., LTD
EUT Type: CDMA/LTE Phone with Bluetooth & WLAN
Liquid Temperature: 21.3 °C
Ambient Temperature: 21.5 °C
Test Date: May.09, 2011

DUT: ADR8995; Type: Bar; Serial: #1

Communication System: LTE; Frequency: 782 MHz; Duty Cycle: 1:1
Medium parameters used (interpolated): $f = 782 \text{ MHz}$; $\sigma = 1 \text{ mho/m}$; $\epsilon_r = 54.2$; $\rho = 1000 \text{ kg/m}^3$
Phantom section: Flat Section ; Measurement SW: DASY4, V4.7 Build 71; Postprocessing SW: SEMCAD, V1.8 Build 184

DASY4 Configuration:

- Probe: ES3DV3 - SN3161; ConvF(5.93, 5.93, 5.93); Calibrated: 2011-03-17
- Sensor-Surface: 4mm (Mechanical Surface Detection)
- Electronics: DAE3 Sn466; Calibrated: 2011-03-01
- Phantom: 800/900 Phantom; Type: SAM

LTE Body Right side QPSK 1 0 23230/Area Scan (41x91x1): Measurement grid: dx=15mm, dy=15mm

[Info: Interpolated medium parameters used for SAR evaluation.](#)

Maximum value of SAR (interpolated) = 0.213 mW/g

LTE Body Right side QPSK 1 0 23230/Zoom Scan (5x5x7)/Cube 0: Measurement grid: dx=8mm, dy=8mm, dz=5mm

Reference Value = 12.6 V/m; Power Drift = -0.069 dB

Peak SAR (extrapolated) = 0.267 W/kg

SAR(1 g) = 0.192 mW/g; SAR(10 g) = 0.134 mW/g

[Info: Interpolated medium parameters used for SAR evaluation.](#)

Maximum value of SAR (measured) = 0.204 mW/g

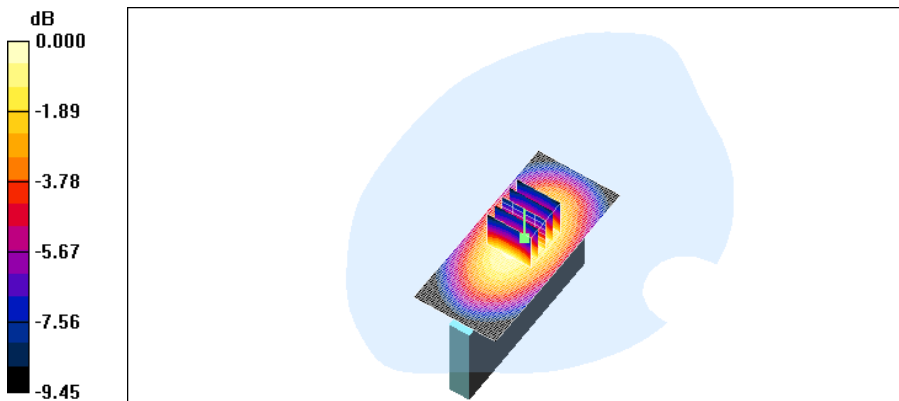

0 dB = 0.204mW/g

Test Laboratory: HCT CO., LTD
EUT Type: CDMA/LTE Phone with Bluetooth & WLAN
Liquid Temperature: 21.3 °C
Ambient Temperature: 21.5 °C
Test Date: May.09, 2011

DUT: ADR8995; Type: Bar; Serial: #1

Communication System: LTE; Frequency: 782 MHz; Duty Cycle: 1:1
Medium parameters used (interpolated): $f = 782 \text{ MHz}$; $\sigma = 1 \text{ mho/m}$; $\epsilon_r = 54.2$; $\rho = 1000 \text{ kg/m}^3$
Phantom section: Flat Section ; Measurement SW: DASY4, V4.7 Build 71; Postprocessing SW: SEMCAD, V1.8 Build 184

DASY4 Configuration:

- Probe: ES3DV3 - SN3161; ConvF(5.93, 5.93, 5.93); Calibrated: 2011-03-17
- Sensor-Surface: 4mm (Mechanical Surface Detection)
- Electronics: DAE3 Sn466; Calibrated: 2011-03-01
- Phantom: 800/900 Phantom; Type: SAM

LTE Body Right side QPSK 1 49 23230/Area Scan (41x91x1): Measurement grid: dx=15mm, dy=15mm

[Info: Interpolated medium parameters used for SAR evaluation.](#)

Maximum value of SAR (interpolated) = 0.230 mW/g

LTE Body Right side QPSK 1 49 23230/Zoom Scan (5x5x7)/Cube 0: Measurement grid: dx=8mm, dy=8mm, dz=5mm

Reference Value = 13.9 V/m; Power Drift = -0.03 dB

Peak SAR (extrapolated) = 0.290 W/kg

SAR(1 g) = 0.218 mW/g; SAR(10 g) = 0.151 mW/g

[Info: Interpolated medium parameters used for SAR evaluation.](#)

Maximum value of SAR (measured) = 0.236 mW/g

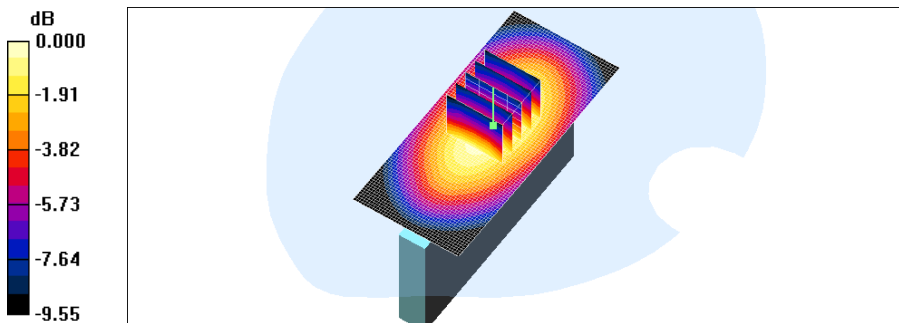

0 dB = 0.236mW/g

Test Laboratory: HCT CO., LTD
EUT Type: CDMA/LTE Phone with Bluetooth & WLAN
Liquid Temperature: 21.3 °C
Ambient Temperature: 21.5 °C
Test Date: May.09, 2011

DUT: ADR8995; Type: Bar; Serial: #1

Communication System: LTE; Frequency: 782 MHz; Duty Cycle: 1:1
Medium parameters used (interpolated): $f = 782 \text{ MHz}$; $\sigma = 1 \text{ mho/m}$; $\epsilon_r = 54.2$; $\rho = 1000 \text{ kg/m}^3$
Phantom section: Flat Section ; Measurement SW: DASY4, V4.7 Build 71; Postprocessing SW: SEMCAD, V1.8 Build 184

DASY4 Configuration:

- Probe: ES3DV3 - SN3161; ConvF(5.93, 5.93, 5.93); Calibrated: 2011-03-17
- Sensor-Surface: 4mm (Mechanical Surface Detection)
- Electronics: DAE3 Sn466; Calibrated: 2011-03-01
- Phantom: 800/900 Phantom; Type: SAM

LTE Body Right side QPSK 25 13 23230/Area Scan (41x91x1): Measurement grid: dx=15mm, dy=15mm

[Info: Interpolated medium parameters used for SAR evaluation.](#)

Maximum value of SAR (interpolated) = 0.159 mW/g

LTE Body Right side QPSK 25 13 23230/Zoom Scan (5x5x7)/Cube 0: Measurement grid: dx=8mm, dy=8mm, dz=5mm

Reference Value = 11.3 V/m; Power Drift = 0.028 dB

Peak SAR (extrapolated) = 0.201 W/kg

SAR(1 g) = 0.150 mW/g; SAR(10 g) = 0.104 mW/g

[Info: Interpolated medium parameters used for SAR evaluation.](#)

Maximum value of SAR (measured) = 0.160 mW/g

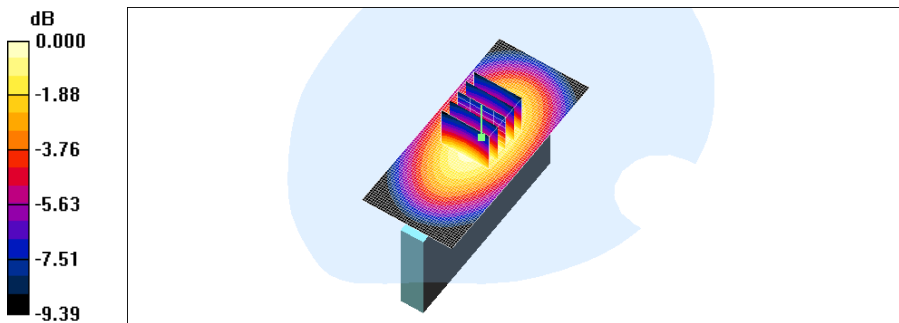

0 dB = 0.160mW/g

Test Laboratory: HCT CO., LTD
EUT Type: CDMA/LTE Phone with Bluetooth & WLAN
Liquid Temperature: 21.3 °C
Ambient Temperature: 21.5 °C
Test Date: May.09, 2011

DUT: ADR8995; Type: Bar; Serial: #1

Communication System: LTE; Frequency: 782 MHz; Duty Cycle: 1:1
Medium parameters used (interpolated): $f = 782 \text{ MHz}$; $\sigma = 1 \text{ mho/m}$; $\epsilon_r = 54.2$; $\rho = 1000 \text{ kg/m}^3$
Phantom section: Flat Section ; Measurement SW: DASY4, V4.7 Build 71; Postprocessing SW: SEMCAD, V1.8 Build 184

DASY4 Configuration:

- Probe: ES3DV3 - SN3161; ConvF(5.93, 5.93, 5.93); Calibrated: 2011-03-17
- Sensor-Surface: 4mm (Mechanical Surface Detection)
- Electronics: DAE3 Sn466; Calibrated: 2011-03-01
- Phantom: 800/900 Phantom; Type: SAM

LTE Body Top side QPSK 1 0 23230/Area Scan (41x61x1): Measurement grid: dx=15mm, dy=15mm

[Info: Interpolated medium parameters used for SAR evaluation.](#)

Maximum value of SAR (interpolated) = 0.057 mW/g

LTE Body Top side QPSK 1 0 23230/Zoom Scan (5x5x7)/Cube 0: Measurement grid: dx=8mm, dy=8mm, dz=5mm

Reference Value = 6.77 V/m; Power Drift = 0.042 dB

Peak SAR (extrapolated) = 0.094 W/kg

SAR(1 g) = 0.052 mW/g; SAR(10 g) = 0.030 mW/g

[Info: Interpolated medium parameters used for SAR evaluation.](#)

Maximum value of SAR (measured) = 0.057 mW/g

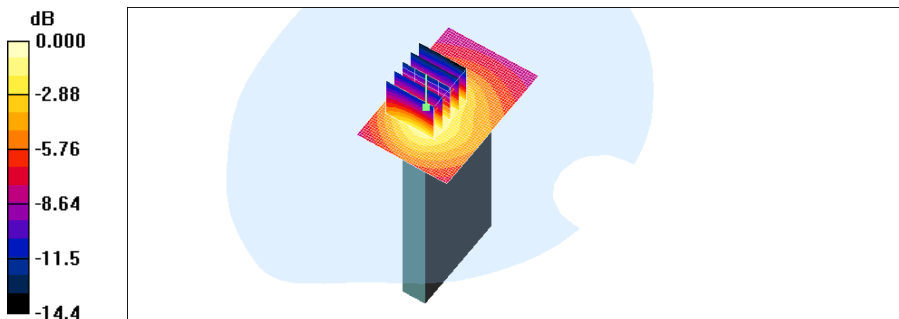

0 dB = 0.057mW/g

Test Laboratory: HCT CO., LTD
EUT Type: CDMA/LTE Phone with Bluetooth & WLAN
Liquid Temperature: 21.3 °C
Ambient Temperature: 21.5 °C
Test Date: May.09, 2011

DUT: ADR8995; Type: Bar; Serial: #1

Communication System: LTE; Frequency: 782 MHz; Duty Cycle: 1:1
Medium parameters used (interpolated): $f = 782 \text{ MHz}$; $\sigma = 1 \text{ mho/m}$; $\epsilon_r = 54.2$; $\rho = 1000 \text{ kg/m}^3$
Phantom section: Flat Section ; Measurement SW: DASY4, V4.7 Build 71; Postprocessing SW: SEMCAD, V1.8 Build 184

DASY4 Configuration:

- Probe: ES3DV3 - SN3161; ConvF(5.93, 5.93, 5.93); Calibrated: 2011-03-17
- Sensor-Surface: 4mm (Mechanical Surface Detection)
- Electronics: DAE3 Sn466; Calibrated: 2011-03-01
- Phantom: 800/900 Phantom; Type: SAM

LTE Body Top side QPSK 1 49 23230/Area Scan (41x61x1): Measurement grid: dx=15mm, dy=15mm

[Info: Interpolated medium parameters used for SAR evaluation.](#)

Maximum value of SAR (interpolated) = 0.066 mW/g

LTE Body Top side QPSK 1 49 23230/Zoom Scan (5x5x7)/Cube 0: Measurement grid: dx=8mm, dy=8mm, dz=5mm

Reference Value = 7.32 V/m; Power Drift = -0.015 dB

Peak SAR (extrapolated) = 0.099 W/kg

SAR(1 g) = 0.058 mW/g; SAR(10 g) = 0.035 mW/g

[Info: Interpolated medium parameters used for SAR evaluation.](#)

Maximum value of SAR (measured) = 0.062 mW/g

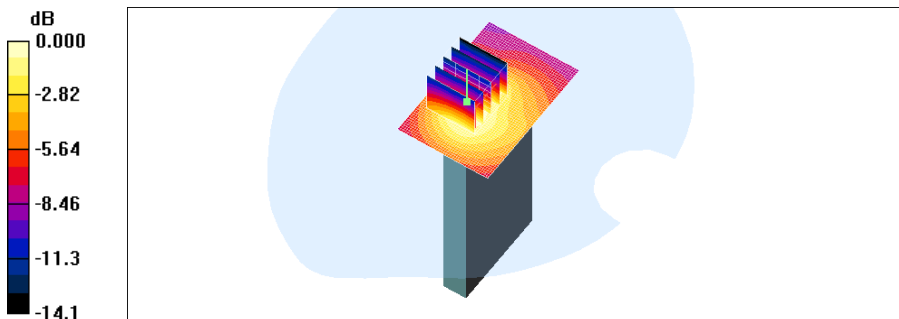

0 dB = 0.062mW/g

Test Laboratory: HCT CO., LTD
EUT Type: CDMA/LTE Phone with Bluetooth & WLAN
Liquid Temperature: 21.3 °C
Ambient Temperature: 21.5 °C
Test Date: May.09, 2011

DUT: ADR8995; Type: Bar; Serial: #1

Communication System: LTE; Frequency: 782 MHz; Duty Cycle: 1:1
Medium parameters used (interpolated): $f = 782$ MHz; $\sigma = 1$ mho/m; $\epsilon_r = 54.2$; $\rho = 1000$ kg/m³
Phantom section: Flat Section ; Measurement SW: DASY4, V4.7 Build 71; Postprocessing SW: SEMCAD, V1.8 Build 184

DASY4 Configuration:

- Probe: ES3DV3 - SN3161; ConvF(5.93, 5.93, 5.93); Calibrated: 2011-03-17
- Sensor-Surface: 4mm (Mechanical Surface Detection)
- Electronics: DAE3 Sn466; Calibrated: 2011-03-01
- Phantom: 800/900 Phantom; Type: SAM

LTE Body Top side QPSK 25 13 23230/Area Scan (41x61x1): Measurement grid: dx=15mm, dy=15mm

[Info: Interpolated medium parameters used for SAR evaluation.](#)

Maximum value of SAR (interpolated) = 0.046 mW/g

LTE Body Top side QPSK 25 13 23230/Zoom Scan (5x5x7)/Cube 0: Measurement grid: dx=8mm, dy=8mm, dz=5mm

Reference Value = 6.02 V/m; Power Drift = 0.117 dB

Peak SAR (extrapolated) = 0.074 W/kg

SAR(1 g) = 0.042 mW/g; SAR(10 g) = 0.024 mW/g

[Info: Interpolated medium parameters used for SAR evaluation.](#)

Maximum value of SAR (measured) = 0.046 mW/g

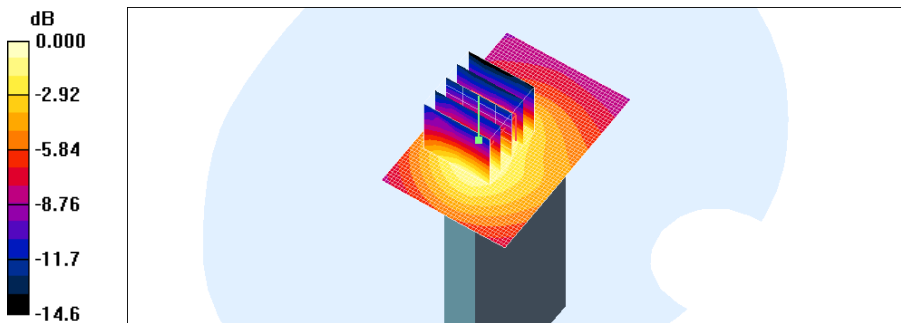

0 dB = 0.046mW/g

Test Laboratory: HCT CO., LTD
EUT Type: CDMA/LTE Phone with Bluetooth & WLAN
Liquid Temperature: 21.3 °C
Ambient Temperature: 21.5 °C
Test Date: May.09, 2011

DUT: ADR8995; Type: Bar; Serial: #1

Communication System: LTE; Frequency: 782 MHz; Duty Cycle: 1:1
Medium parameters used (interpolated): $f = 782 \text{ MHz}$; $\sigma = 1 \text{ mho/m}$; $\epsilon_r = 54.2$; $\rho = 1000 \text{ kg/m}^3$
Phantom section: Flat Section ; Measurement SW: DASY4, V4.7 Build 71; Postprocessing SW: SEMCAD, V1.8 Build 184

DASY4 Configuration:

- Probe: ES3DV3 - SN3161; ConvF(5.93, 5.93, 5.93); Calibrated: 2011-03-17
- Sensor-Surface: 4mm (Mechanical Surface Detection)
- Electronics: DAE3 Sn466; Calibrated: 2011-03-01
- Phantom: 800/900 Phantom; Type: SAM

LTE Body Front 16QAM 1 0 23230/Area Scan (51x91x1): Measurement grid: dx=15mm, dy=15mm

[Info: Interpolated medium parameters used for SAR evaluation.](#)

Maximum value of SAR (interpolated) = 0.121 mW/g

LTE Body Front 16QAM 1 0 23230/Zoom Scan (5x5x7)/Cube 0: Measurement grid: dx=8mm, dy=8mm, dz=5mm

Reference Value = 10.4 V/m; Power Drift = -0.020 dB

Peak SAR (extrapolated) = 0.146 W/kg

SAR(1 g) = 0.116 mW/g; SAR(10 g) = 0.087 mW/g

[Info: Interpolated medium parameters used for SAR evaluation.](#)

Maximum value of SAR (measured) = 0.122 mW/g

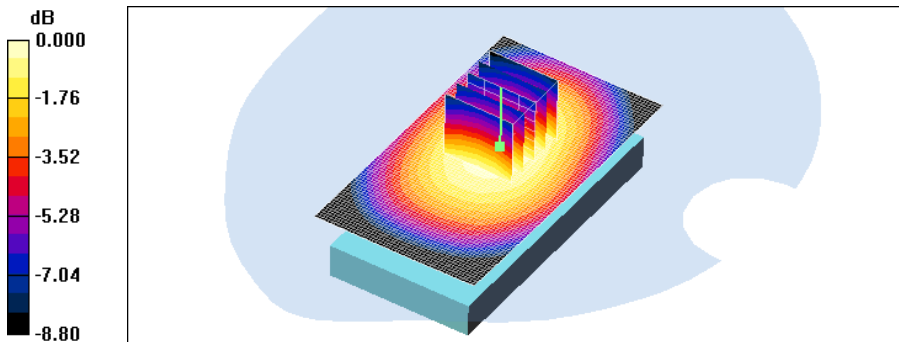

0 dB = 0.122mW/g

Test Laboratory: HCT CO., LTD
EUT Type: CDMA/LTE Phone with Bluetooth & WLAN
Liquid Temperature: 21.3 °C
Ambient Temperature: 21.5 °C
Test Date: May.09, 2011

DUT: ADR8995; Type: Bar; Serial: #1

Communication System: LTE; Frequency: 782 MHz; Duty Cycle: 1:1
Medium parameters used (interpolated): $f = 782 \text{ MHz}$; $\sigma = 1 \text{ mho/m}$; $\epsilon_r = 54.2$; $\rho = 1000 \text{ kg/m}^3$
Phantom section: Flat Section ; Measurement SW: DASY4, V4.7 Build 71; Postprocessing SW: SEMCAD, V1.8 Build 184

DASY4 Configuration:

- Probe: ES3DV3 - SN3161; ConvF(5.93, 5.93, 5.93); Calibrated: 2011-03-17
- Sensor-Surface: 4mm (Mechanical Surface Detection)
- Electronics: DAE3 Sn466; Calibrated: 2011-03-01
- Phantom: 800/900 Phantom; Type: SAM

LTE Body Front 16QAM 1 49 23230/Area Scan (51x91x1): Measurement grid: dx=15mm, dy=15mm

[Info: Interpolated medium parameters used for SAR evaluation.](#)

Maximum value of SAR (interpolated) = 0.153 mW/g

LTE Body Front 16QAM 1 49 23230/Zoom Scan (5x5x7)/Cube 0: Measurement grid: dx=8mm, dy=8mm, dz=5mm

Reference Value = 11.6 V/m; Power Drift = 0.005 dB

Peak SAR (extrapolated) = 0.179 W/kg

SAR(1 g) = 0.141 mW/g; SAR(10 g) = 0.105 mW/g

[Info: Interpolated medium parameters used for SAR evaluation.](#)

Maximum value of SAR (measured) = 0.148 mW/g

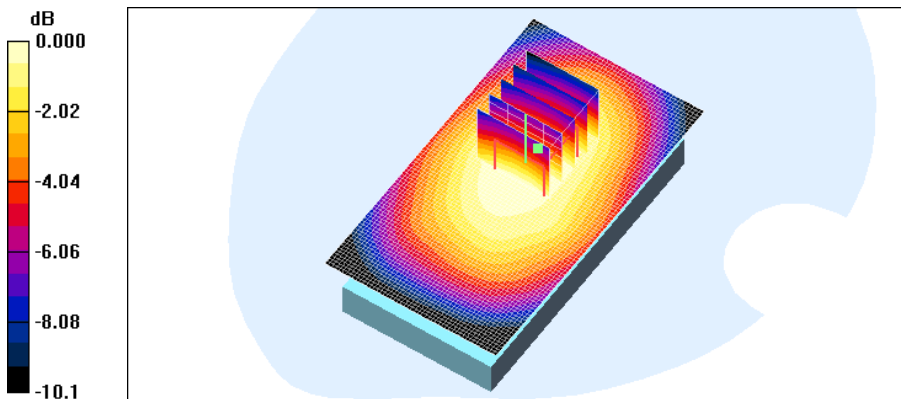

Test Laboratory: HCT CO., LTD
EUT Type: CDMA/LTE Phone with Bluetooth & WLAN
Liquid Temperature: 21.3 °C
Ambient Temperature: 21.5 °C
Test Date: May.09, 2011

DUT: ADR8995; Type: Bar; Serial: #1

Communication System: LTE; Frequency: 782 MHz; Duty Cycle: 1:1
Medium parameters used (interpolated): $f = 782$ MHz; $\sigma = 1$ mho/m; $\epsilon_r = 54.2$; $\rho = 1000$ kg/m³
Phantom section: Flat Section ; Measurement SW: DASY4, V4.7 Build 71; Postprocessing SW: SEMCAD, V1.8 Build 184

DASY4 Configuration:

- Probe: ES3DV3 - SN3161; ConvF(5.93, 5.93, 5.93); Calibrated: 2011-03-17
- Sensor-Surface: 4mm (Mechanical Surface Detection)
- Electronics: DAE3 Sn466; Calibrated: 2011-03-01
- Phantom: 800/900 Phantom; Type: SAM

LTE Body Front 16QAM 25 13 23230/Area Scan (51x91x1): Measurement grid: dx=15mm, dy=15mm

[Info: Interpolated medium parameters used for SAR evaluation.](#)

Maximum value of SAR (interpolated) = 0.105 mW/g

LTE Body Front 16QAM 25 13 23230/Zoom Scan (5x5x7)/Cube 0: Measurement grid: dx=8mm, dy=8mm, dz=5mm

Reference Value = 9.76 V/m; Power Drift = 0.071 dB

Peak SAR (extrapolated) = 0.126 W/kg

SAR(1 g) = 0.101 mW/g; SAR(10 g) = 0.076 mW/g

[Info: Interpolated medium parameters used for SAR evaluation.](#)

Maximum value of SAR (measured) = 0.107 mW/g

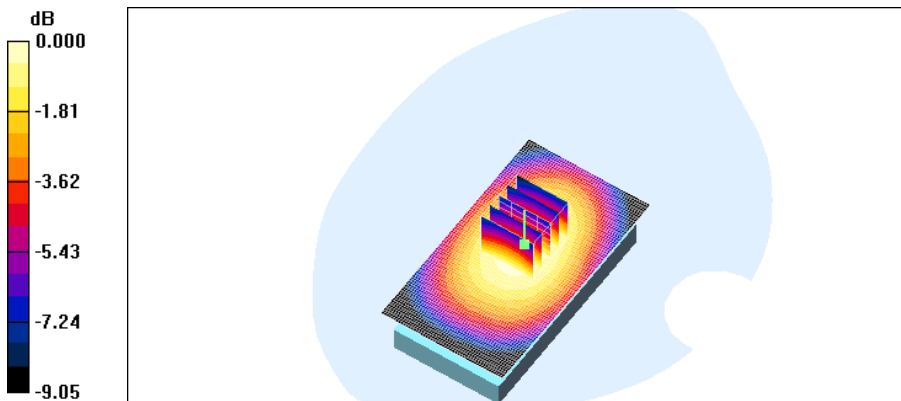

0 dB = 0.107mW/g

Test Laboratory: HCT CO., LTD
EUT Type: CDMA/LTE Phone with Bluetooth & WLAN
Liquid Temperature: 21.3 °C
Ambient Temperature: 21.5 °C
Test Date: May.09, 2011

DUT: ADR8995; Type: Bar; Serial: #1

Communication System: LTE; Frequency: 782 MHz; Duty Cycle: 1:1
Medium parameters used (interpolated): $f = 782 \text{ MHz}$; $\sigma = 1 \text{ mho/m}$; $\epsilon_r = 54.2$; $\rho = 1000 \text{ kg/m}^3$
Phantom section: Flat Section ; Measurement SW: DASY4, V4.7 Build 71; Postprocessing SW: SEMCAD, V1.8 Build 184

DASY4 Configuration:

- Probe: ES3DV3 - SN3161; ConvF(5.93, 5.93, 5.93); Calibrated: 2011-03-17
- Sensor-Surface: 4mm (Mechanical Surface Detection)
- Electronics: DAE3 Sn466; Calibrated: 2011-03-01
- Phantom: 800/900 Phantom; Type: SAM

LTE Body Rear 16QAM 1 0 23230/Area Scan (51x91x1): Measurement grid: dx=15mm, dy=15mm

[Info: Interpolated medium parameters used for SAR evaluation.](#)

Maximum value of SAR (interpolated) = 0.456 mW/g

LTE Body Rear 16QAM 1 0 23230/Zoom Scan (5x5x7)/Cube 0: Measurement grid: dx=8mm, dy=8mm, dz=5mm

Reference Value = 18.9 V/m; Power Drift = -0.009 dB

Peak SAR (extrapolated) = 0.544 W/kg

SAR(1 g) = 0.428 mW/g; SAR(10 g) = 0.316 mW/g

[Info: Interpolated medium parameters used for SAR evaluation.](#)

Maximum value of SAR (measured) = 0.453 mW/g

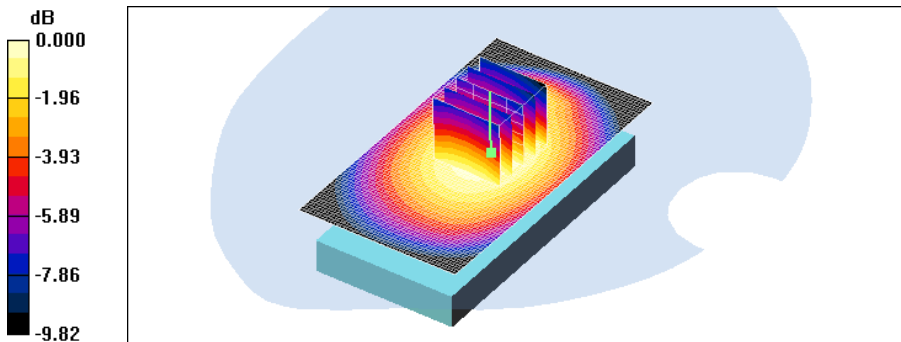

0 dB = 0.453mW/g

Test Laboratory: HCT CO., LTD
EUT Type: CDMA/LTE Phone with Bluetooth & WLAN
Liquid Temperature: 21.3 °C
Ambient Temperature: 21.5 °C
Test Date: May.09, 2011

DUT: ADR8995; Type: Bar; Serial: #1

Communication System: LTE; Frequency: 782 MHz; Duty Cycle: 1:1
Medium parameters used (interpolated): $f = 782 \text{ MHz}$; $\sigma = 1 \text{ mho/m}$; $\epsilon_r = 54.2$; $\rho = 1000 \text{ kg/m}^3$
Phantom section: Flat Section ; Measurement SW: DASY4, V4.7 Build 71; Postprocessing SW: SEMCAD, V1.8 Build 184

DASY4 Configuration:

- Probe: ES3DV3 - SN3161; ConvF(5.93, 5.93, 5.93); Calibrated: 2011-03-17
- Sensor-Surface: 4mm (Mechanical Surface Detection)
- Electronics: DAE3 Sn466; Calibrated: 2011-03-01
- Phantom: 800/900 Phantom; Type: SAM

LTE Body Rear 16QAM 1 49 23230/Area Scan (51x91x1): Measurement grid: dx=15mm, dy=15mm

[Info: Interpolated medium parameters used for SAR evaluation.](#)

Maximum value of SAR (interpolated) = 0.429 mW/g

LTE Body Rear 16QAM 1 49 23230/Zoom Scan (5x5x7)/Cube 0: Measurement grid: dx=8mm, dy=8mm, dz=5mm

Reference Value = 18.3 V/m; Power Drift = -0.014 dB

Peak SAR (extrapolated) = 0.502 W/kg

SAR(1 g) = 0.387 mW/g; SAR(10 g) = 0.284 mW/g

[Info: Interpolated medium parameters used for SAR evaluation.](#)

Maximum value of SAR (measured) = 0.417 mW/g

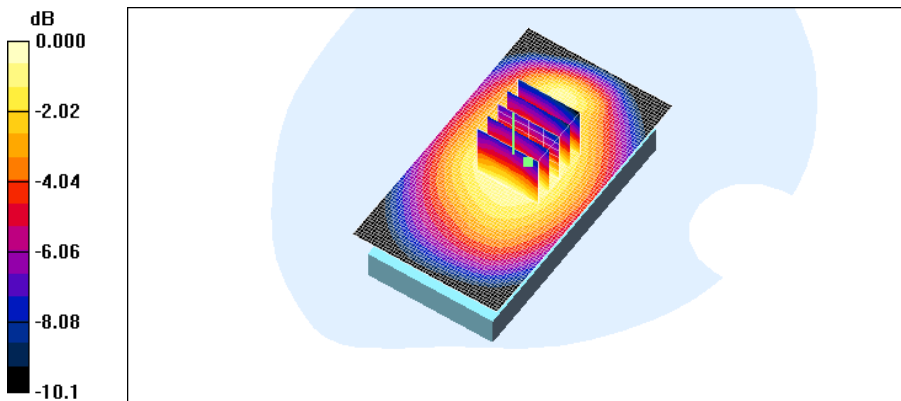

0 dB = 0.417mW/g

Test Laboratory: HCT CO., LTD
EUT Type: CDMA/LTE Phone with Bluetooth & WLAN
Liquid Temperature: 21.3 °C
Ambient Temperature: 21.5 °C
Test Date: May.09, 2011

DUT: ADR8995; Type: Bar; Serial: #1

Communication System: LTE; Frequency: 782 MHz; Duty Cycle: 1:1
Medium parameters used (interpolated): $f = 782$ MHz; $\sigma = 1$ mho/m; $\epsilon_r = 54.2$; $\rho = 1000$ kg/m³
Phantom section: Flat Section ; Measurement SW: DASY4, V4.7 Build 71; Postprocessing SW: SEMCAD, V1.8 Build 184

DASY4 Configuration:

- Probe: ES3DV3 - SN3161; ConvF(5.93, 5.93, 5.93); Calibrated: 2011-03-17
- Sensor-Surface: 4mm (Mechanical Surface Detection)
- Electronics: DAE3 Sn466; Calibrated: 2011-03-01
- Phantom: 800/900 Phantom; Type: SAM

LTE Body16QAM 25 13 23230/Area Scan (51x91x1): Measurement grid: dx=15mm, dy=15mm

[Info: Interpolated medium parameters used for SAR evaluation.](#)

Maximum value of SAR (interpolated) = 0.299 mW/g

LTE Body16QAM 25 13 23230/Zoom Scan (5x5x7)/Cube 0: Measurement grid: dx=8mm, dy=8mm, dz=5mm

Reference Value = 15.4 V/m; Power Drift = 0.009 dB

Peak SAR (extrapolated) = 0.360 W/kg

SAR(1 g) = 0.283 mW/g; SAR(10 g) = 0.208 mW/g

[Info: Interpolated medium parameters used for SAR evaluation.](#)

Maximum value of SAR (measured) = 0.298 mW/g

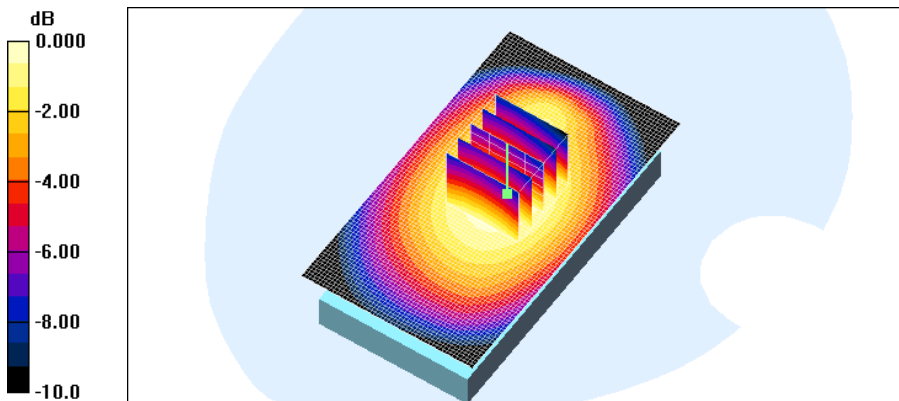

0 dB = 0.298mW/g

Test Laboratory: HCT CO., LTD
EUT Type: CDMA/LTE Phone with Bluetooth & WLAN
Liquid Temperature: 21.3 °C
Ambient Temperature: 21.5 °C
Test Date: May.09, 2011

DUT: ADR8995; Type: Bar; Serial: #1

Communication System: LTE; Frequency: 782 MHz; Duty Cycle: 1:1
Medium parameters used (interpolated): $f = 782 \text{ MHz}$; $\sigma = 1 \text{ mho/m}$; $\epsilon_r = 54.2$; $\rho = 1000 \text{ kg/m}^3$
Phantom section: Flat Section ; Measurement SW: DASY4, V4.7 Build 71; Postprocessing SW: SEMCAD, V1.8 Build 184

DASY4 Configuration:

- Probe: ES3DV3 - SN3161; ConvF(5.93, 5.93, 5.93); Calibrated: 2011-03-17
- Sensor-Surface: 4mm (Mechanical Surface Detection)
- Electronics: DAE3 Sn466; Calibrated: 2011-03-01
- Phantom: 800/900 Phantom; Type: SAM

LTE Body Left side 16QAM 1 0 23230/Area Scan (41x91x1): Measurement grid: dx=15mm, dy=15mm

[Info: Interpolated medium parameters used for SAR evaluation.](#)

Maximum value of SAR (interpolated) = 0.119 mW/g

LTE Body Left side 16QAM 1 0 23230/Zoom Scan (5x5x7)/Cube 0: Measurement grid: dx=8mm, dy=8mm, dz=5mm

Reference Value = 9.24 V/m; Power Drift = 0.018 dB

Peak SAR (extrapolated) = 0.179 W/kg

SAR(1 g) = 0.118 mW/g; SAR(10 g) = 0.079 mW/g

[Info: Interpolated medium parameters used for SAR evaluation.](#)

Maximum value of SAR (measured) = 0.131 mW/g

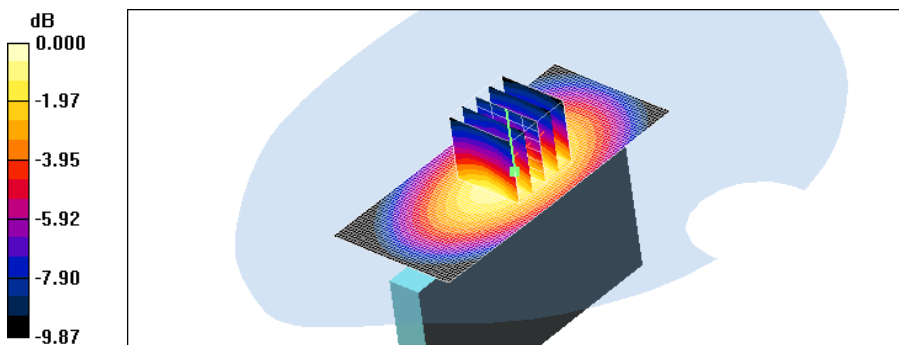

0 dB = 0.131mW/g

Test Laboratory: HCT CO., LTD
EUT Type: CDMA/LTE Phone with Bluetooth & WLAN
Liquid Temperature: 21.3 °C
Ambient Temperature: 21.5 °C
Test Date: May.09, 2011

DUT: ADR8995; Type: Bar; Serial: #1

Communication System: LTE; Frequency: 782 MHz; Duty Cycle: 1:1
Medium parameters used (interpolated): $f = 782 \text{ MHz}$; $\sigma = 1 \text{ mho/m}$; $\epsilon_r = 54.2$; $\rho = 1000 \text{ kg/m}^3$
Phantom section: Flat Section ; Measurement SW: DASY4, V4.7 Build 71; Postprocessing SW: SEMCAD, V1.8 Build 184

DASY4 Configuration:

- Probe: ES3DV3 - SN3161; ConvF(5.93, 5.93, 5.93); Calibrated: 2011-03-17
- Sensor-Surface: 4mm (Mechanical Surface Detection)
- Electronics: DAE3 Sn466; Calibrated: 2011-03-01
- Phantom: 800/900 Phantom; Type: SAM

LTE Body Left side 16QAM 1 49 23230/Area Scan (41x91x1): Measurement grid: dx=15mm, dy=15mm

[Info: Interpolated medium parameters used for SAR evaluation.](#)

Maximum value of SAR (interpolated) = 0.149 mW/g

LTE Body Left side 16QAM 1 49 23230/Zoom Scan (5x5x7)/Cube 0: Measurement grid: dx=8mm, dy=8mm, dz=5mm

Reference Value = 10.2 V/m; Power Drift = -0.036 dB

Peak SAR (extrapolated) = 0.192 W/kg

SAR(1 g) = 0.139 mW/g; SAR(10 g) = 0.097 mW/g

[Info: Interpolated medium parameters used for SAR evaluation.](#)

Maximum value of SAR (measured) = 0.149 mW/g

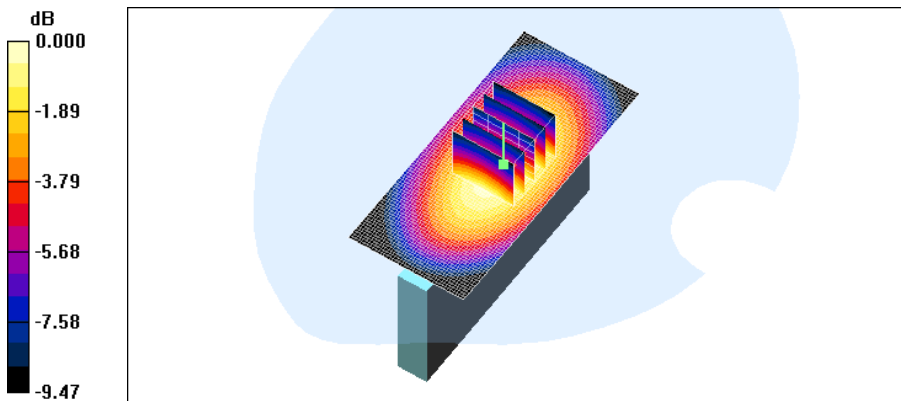

0 dB = 0.149mW/g

Test Laboratory: HCT CO., LTD
EUT Type: CDMA/LTE Phone with Bluetooth & WLAN
Liquid Temperature: 21.3 °C
Ambient Temperature: 21.5 °C
Test Date: May.09, 2011

DUT: ADR8995; Type: Bar; Serial: #1

Communication System: LTE; Frequency: 782 MHz; Duty Cycle: 1:1
Medium parameters used (interpolated): $f = 782 \text{ MHz}$; $\sigma = 1 \text{ mho/m}$; $\epsilon_r = 54.2$; $\rho = 1000 \text{ kg/m}^3$
Phantom section: Flat Section ; Measurement SW: DASY4, V4.7 Build 71; Postprocessing SW: SEMCAD, V1.8 Build 184

DASY4 Configuration:

- Probe: ES3DV3 - SN3161; ConvF(5.93, 5.93, 5.93); Calibrated: 2011-03-17
- Sensor-Surface: 4mm (Mechanical Surface Detection)
- Electronics: DAE3 Sn466; Calibrated: 2011-03-01
- Phantom: 800/900 Phantom; Type: SAM

LTE Body Left side 16QAM 25 13 23230/Area Scan (41x91x1): Measurement grid: dx=15mm, dy=15mm

[Info: Interpolated medium parameters used for SAR evaluation.](#)

Maximum value of SAR (interpolated) = 0.104 mW/g

LTE Body Left side 16QAM 25 13 23230/Zoom Scan (5x5x7)/Cube 0: Measurement grid: dx=8mm, dy=8mm, dz=5mm

Reference Value = 8.56 V/m; Power Drift = 0.008 dB

Peak SAR (extrapolated) = 0.136 W/kg

SAR(1 g) = 0.098 mW/g; SAR(10 g) = 0.068 mW/g

[Info: Interpolated medium parameters used for SAR evaluation.](#)

Maximum value of SAR (measured) = 0.104 mW/g

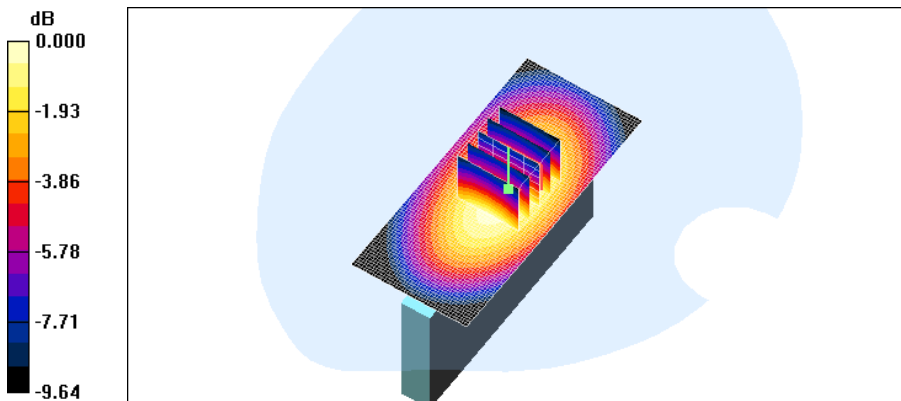

0 dB = 0.104mW/g

Test Laboratory: HCT CO., LTD
EUT Type: CDMA/LTE Phone with Bluetooth & WLAN
Liquid Temperature: 21.3 °C
Ambient Temperature: 21.5 °C
Test Date: May.09, 2011

DUT: ADR8995; Type: Bar; Serial: #1

Communication System: LTE; Frequency: 782 MHz; Duty Cycle: 1:1
Medium parameters used (interpolated): $f = 782$ MHz; $\sigma = 1$ mho/m; $\epsilon_r = 54.2$; $\rho = 1000$ kg/m³
Phantom section: Flat Section ; Measurement SW: DASY4, V4.7 Build 71; Postprocessing SW: SEMCAD, V1.8 Build 184

DASY4 Configuration:

- Probe: ES3DV3 - SN3161; ConvF(5.93, 5.93, 5.93); Calibrated: 2011-03-17
- Sensor-Surface: 4mm (Mechanical Surface Detection)
- Electronics: DAE3 Sn466; Calibrated: 2011-03-01
- Phantom: 800/900 Phantom; Type: SAM

LTE Body Right side 16QAM 1 0 23230/Area Scan (41x91x1): Measurement grid: dx=15mm, dy=15mm

[Info: Interpolated medium parameters used for SAR evaluation.](#)

Maximum value of SAR (interpolated) = 0.153 mW/g

LTE Body Right side 16QAM 1 0 23230/Zoom Scan (5x5x7)/Cube 0: Measurement grid: dx=8mm, dy=8mm, dz=5mm

Reference Value = 10.8 V/m; Power Drift = 0.040 dB

Peak SAR (extrapolated) = 0.208 W/kg

SAR(1 g) = 0.152 mW/g; SAR(10 g) = 0.106 mW/g

[Info: Interpolated medium parameters used for SAR evaluation.](#)

Maximum value of SAR (measured) = 0.161 mW/g

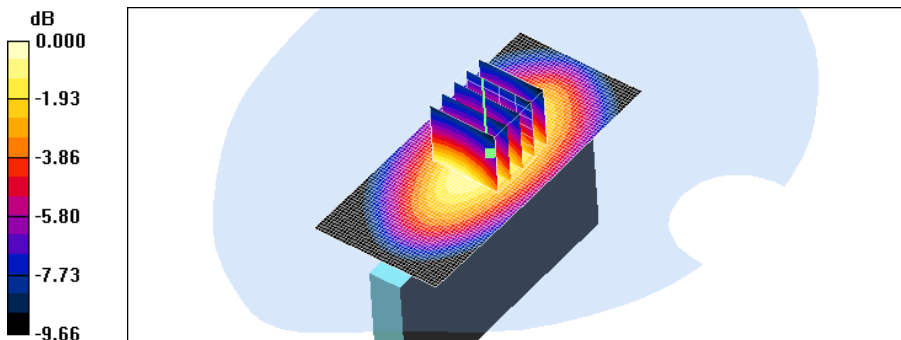

0 dB = 0.161mW/g

Test Laboratory: HCT CO., LTD
EUT Type: CDMA/LTE Phone with Bluetooth & WLAN
Liquid Temperature: 21.3 °C
Ambient Temperature: 21.5 °C
Test Date: May.09, 2011

DUT: ADR8995; Type: Bar; Serial: #1

Communication System: LTE; Frequency: 782 MHz; Duty Cycle: 1:1
Medium parameters used (interpolated): $f = 782 \text{ MHz}$; $\sigma = 1 \text{ mho/m}$; $\epsilon_r = 54.2$; $\rho = 1000 \text{ kg/m}^3$
Phantom section: Flat Section ; Measurement SW: DASY4, V4.7 Build 71; Postprocessing SW: SEMCAD, V1.8 Build 184

DASY4 Configuration:

- Probe: ES3DV3 - SN3161; ConvF(5.93, 5.93, 5.93); Calibrated: 2011-03-17
- Sensor-Surface: 4mm (Mechanical Surface Detection)
- Electronics: DAE3 Sn466; Calibrated: 2011-03-01
- Phantom: 800/900 Phantom; Type: SAM

LTE Body Right side 16QAM 1 49 23230/Area Scan (41x91x1): Measurement grid: dx=15mm, dy=15mm

[Info: Interpolated medium parameters used for SAR evaluation.](#)

Maximum value of SAR (interpolated) = 0.202 mW/g

LTE Body Right side 16QAM 1 49 23230/Zoom Scan (5x5x7)/Cube 0: Measurement grid: dx=8mm, dy=8mm, dz=5mm

Reference Value = 12.5 V/m; Power Drift = 0.038 dB

Peak SAR (extrapolated) = 0.266 W/kg

SAR(1 g) = 0.191 mW/g; SAR(10 g) = 0.133 mW/g

[Info: Interpolated medium parameters used for SAR evaluation.](#)

Maximum value of SAR (measured) = 0.206 mW/g

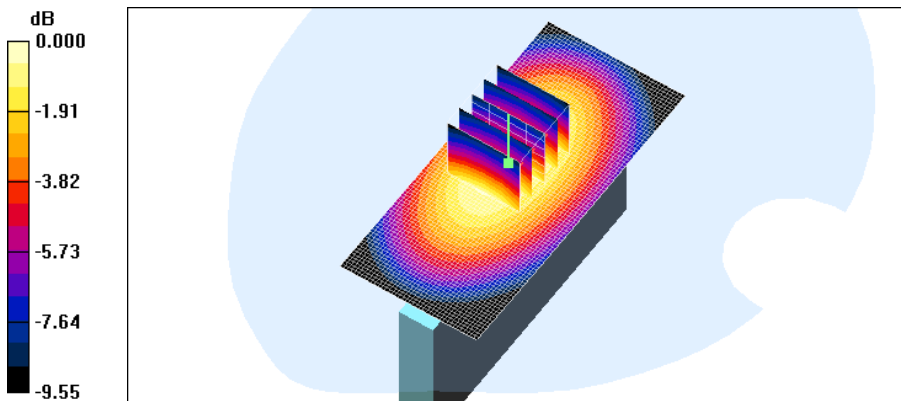

0 dB = 0.206mW/g

Test Laboratory: HCT CO., LTD
EUT Type: CDMA/LTE Phone with Bluetooth & WLAN
Liquid Temperature: 21.3 °C
Ambient Temperature: 21.5 °C
Test Date: May.09, 2011

DUT: ADR8995; Type: Bar; Serial: #1

Communication System: LTE; Frequency: 782 MHz; Duty Cycle: 1:1
Medium parameters used (interpolated): $f = 782 \text{ MHz}$; $\sigma = 1 \text{ mho/m}$; $\epsilon_r = 54.2$; $\rho = 1000 \text{ kg/m}^3$
Phantom section: Flat Section ; Measurement SW: DASY4, V4.7 Build 71; Postprocessing SW: SEMCAD, V1.8 Build 184

DASY4 Configuration:

- Probe: ES3DV3 - SN3161; ConvF(5.93, 5.93, 5.93); Calibrated: 2011-03-17
- Sensor-Surface: 4mm (Mechanical Surface Detection)
- Electronics: DAE3 Sn466; Calibrated: 2011-03-01
- Phantom: 800/900 Phantom; Type: SAM

LTE Body Right side 16QAM 25 13 23230/Area Scan (41x91x1): Measurement grid: dx=15mm, dy=15mm

[Info: Interpolated medium parameters used for SAR evaluation.](#)

Maximum value of SAR (interpolated) = 0.147 mW/g

LTE Body Right side 16QAM 25 13 23230/Zoom Scan (5x5x7)/Cube 0: Measurement grid: dx=8mm, dy=8mm, dz=5mm

Reference Value = 10.6 V/m; Power Drift = 0.072 dB

Peak SAR (extrapolated) = 0.189 W/kg

SAR(1 g) = 0.138 mW/g; SAR(10 g) = 0.097 mW/g

[Info: Interpolated medium parameters used for SAR evaluation.](#)

Maximum value of SAR (measured) = 0.148 mW/g

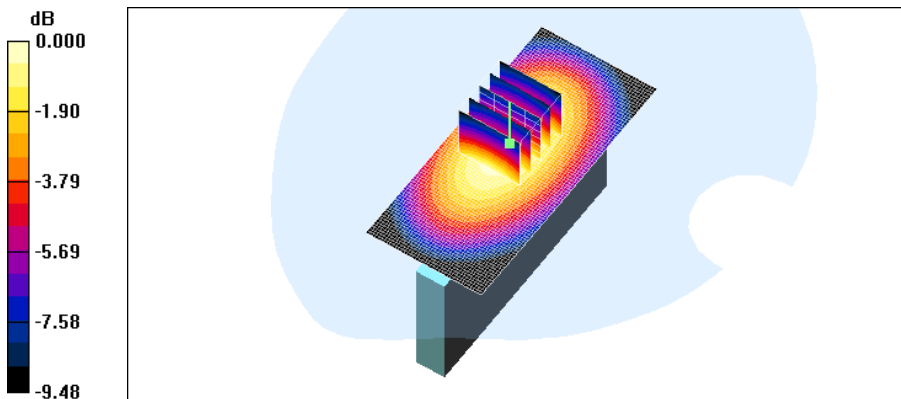

0 dB = 0.148mW/g

Test Laboratory: HCT CO., LTD
EUT Type: CDMA/LTE Phone with Bluetooth & WLAN
Liquid Temperature: 21.3 °C
Ambient Temperature: 21.5 °C
Test Date: May.09, 2011

DUT: ADR8995; Type: Bar; Serial: #1

Communication System: LTE; Frequency: 782 MHz; Duty Cycle: 1:1
Medium parameters used (interpolated): $f = 782 \text{ MHz}$; $\sigma = 1 \text{ mho/m}$; $\epsilon_r = 54.2$; $\rho = 1000 \text{ kg/m}^3$
Phantom section: Flat Section ; Measurement SW: DASY4, V4.7 Build 71; Postprocessing SW: SEMCAD, V1.8 Build 184

DASY4 Configuration:

- Probe: ES3DV3 - SN3161; ConvF(5.93, 5.93, 5.93); Calibrated: 2011-03-17
- Sensor-Surface: 4mm (Mechanical Surface Detection)
- Electronics: DAE3 Sn466; Calibrated: 2011-03-01
- Phantom: 800/900 Phantom; Type: SAM

LTE Body Top side 16QAM 1 0 23230/Area Scan (41x61x1): Measurement grid: dx=15mm, dy=15mm

[Info: Interpolated medium parameters used for SAR evaluation.](#)

Maximum value of SAR (interpolated) = 0.045 mW/g

LTE Body Top side 16QAM 1 0 23230/Zoom Scan (5x5x7)/Cube 0: Measurement grid: dx=8mm, dy=8mm, dz=5mm

Reference Value = 5.86 V/m; Power Drift = 0.060 dB

Peak SAR (extrapolated) = 0.071 W/kg

SAR(1 g) = 0.040 mW/g; SAR(10 g) = 0.023 mW/g

[Info: Interpolated medium parameters used for SAR evaluation.](#)

Maximum value of SAR (measured) = 0.044 mW/g

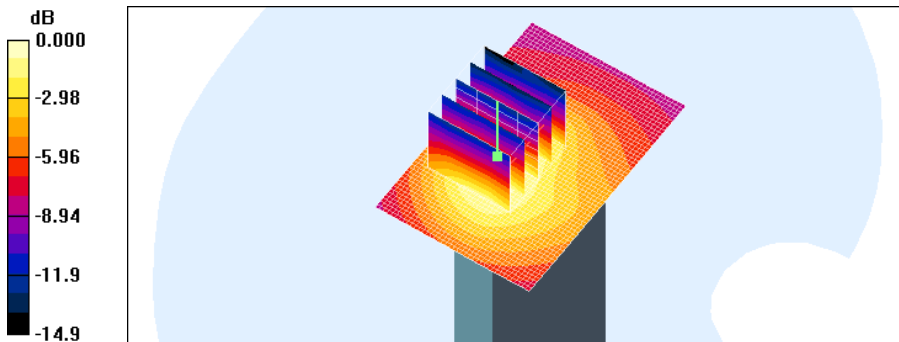

0 dB = 0.044mW/g

Test Laboratory: HCT CO., LTD
EUT Type: CDMA/LTE Phone with Bluetooth & WLAN
Liquid Temperature: 21.3 °C
Ambient Temperature: 21.5 °C
Test Date: May.09, 2011

DUT: ADR8995; Type: Bar; Serial: #1

Communication System: LTE; Frequency: 782 MHz; Duty Cycle: 1:1
Medium parameters used (interpolated): $f = 782$ MHz; $\sigma = 1$ mho/m; $\epsilon_r = 54.2$; $\rho = 1000$ kg/m³
Phantom section: Flat Section ; Measurement SW: DASY4, V4.7 Build 71; Postprocessing SW: SEMCAD, V1.8 Build 184

DASY4 Configuration:

- Probe: ES3DV3 - SN3161; ConvF(5.93, 5.93, 5.93); Calibrated: 2011-03-17
- Sensor-Surface: 4mm (Mechanical Surface Detection)
- Electronics: DAE3 Sn466; Calibrated: 2011-03-01
- Phantom: 800/900 Phantom; Type: SAM

LTE Body Top side 16QAM 1 49 23230/Area Scan (41x61x1): Measurement grid: dx=15mm, dy=15mm

[Info: Interpolated medium parameters used for SAR evaluation.](#)

Maximum value of SAR (interpolated) = 0.072 mW/g

LTE Body Top side 16QAM 1 49 23230/Zoom Scan (5x5x7)/Cube 0: Measurement grid: dx=8mm, dy=8mm, dz=5mm

Reference Value = 7.73 V/m; Power Drift = -0.066 dB

Peak SAR (extrapolated) = 0.120 W/kg

SAR(1 g) = 0.064 mW/g; SAR(10 g) = 0.037 mW/g

[Info: Interpolated medium parameters used for SAR evaluation.](#)

Maximum value of SAR (measured) = 0.070 mW/g

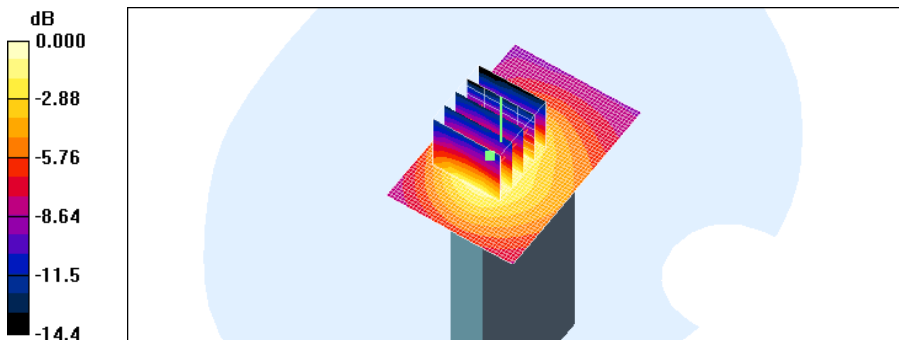

0 dB = 0.070mW/g

Test Laboratory: HCT CO., LTD
EUT Type: CDMA/LTE Phone with Bluetooth & WLAN
Liquid Temperature: 21.3 °C
Ambient Temperature: 21.5 °C
Test Date: May.09, 2011

DUT: ADR8995; Type: Bar; Serial: #1

Communication System: LTE; Frequency: 782 MHz; Duty Cycle: 1:1
Medium parameters used (interpolated): $f = 782$ MHz; $\sigma = 1$ mho/m; $\epsilon_r = 54.2$; $\rho = 1000$ kg/m³
Phantom section: Flat Section ; Measurement SW: DASY4, V4.7 Build 71; Postprocessing SW: SEMCAD, V1.8 Build 184

DASY4 Configuration:

- Probe: ES3DV3 - SN3161; ConvF(5.93, 5.93, 5.93); Calibrated: 2011-03-17
- Sensor-Surface: 4mm (Mechanical Surface Detection)
- Electronics: DAE3 Sn466; Calibrated: 2011-03-01
- Phantom: 800/900 Phantom; Type: SAM

LTE Body Top side 16QAM 25 13 23230/Area Scan (41x61x1): Measurement grid: dx=15mm, dy=15mm

[Info: Interpolated medium parameters used for SAR evaluation.](#)

Maximum value of SAR (interpolated) = 0.040 mW/g

LTE Body Top side 16QAM 25 13 23230/Zoom Scan (5x5x7)/Cube 0: Measurement grid: dx=8mm, dy=8mm, dz=5mm

Reference Value = 5.49 V/m; Power Drift = 0.012 dB

Peak SAR (extrapolated) = 0.063 W/kg

SAR(1 g) = 0.035 mW/g; SAR(10 g) = 0.021 mW/g

[Info: Interpolated medium parameters used for SAR evaluation.](#)

Maximum value of SAR (measured) = 0.039 mW/g

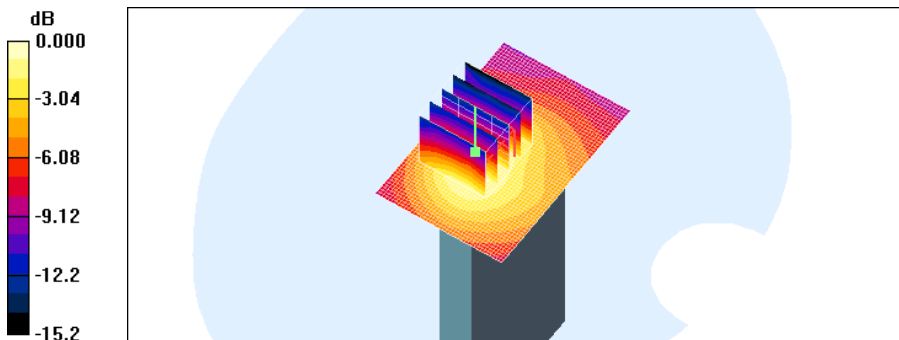

0 dB = 0.039mW/g

Test Laboratory: HCT CO., LTD
EUT Type: CDMA/LTE Phone with Bluetooth & WLAN
Liquid Temperature: 21.3 °C
Ambient Temperature: 21.5 °C
Test Date: Jun.08, 2011

DUT: ADR8995; Type: Bar; Serial: #1

Communication System: CDMA 835MHz FCC; Frequency: 836.52 MHz; Duty Cycle: 1:1
Medium parameters used (interpolated): $f = 836.52$ MHz; $\sigma = 0.889$ mho/m; $\epsilon_r = 41.4$; $\rho = 1000$ kg/m³
Phantom section: Left Section ; Measurement SW: DASY4, V4.7 Build 71; Postprocessing SW: SEMCAD, V1.8 Build 184

DASY4 Configuration:

- Probe: ES3DV3 - SN3161; ConvF(5.84, 5.84, 5.84); Calibrated: 2011-03-17
- Sensor-Surface: 4mm (Mechanical Surface Detection)
- Electronics: DAE3 Sn466; Calibrated: 2011-03-01
- Phantom: 800/900 Phantom; Type: SAM

Left touch 384/Area Scan (51x91x1): Measurement grid: dx=15mm, dy=15mm

[Info: Interpolated medium parameters used for SAR evaluation.](#)

Maximum value of SAR (interpolated) = 0.691 mW/g

Left touch 384/Zoom Scan (5x5x7)/Cube 0: Measurement grid: dx=8mm, dy=8mm, dz=5mm

Reference Value = 24.4 V/m; Power Drift = -0.133 dB

Peak SAR (extrapolated) = 0.944 W/kg

SAR(1 g) = 0.598 mW/g; SAR(10 g) = 0.407 mW/g

[Info: Interpolated medium parameters used for SAR evaluation.](#)

Maximum value of SAR (measured) = 0.631 mW/g

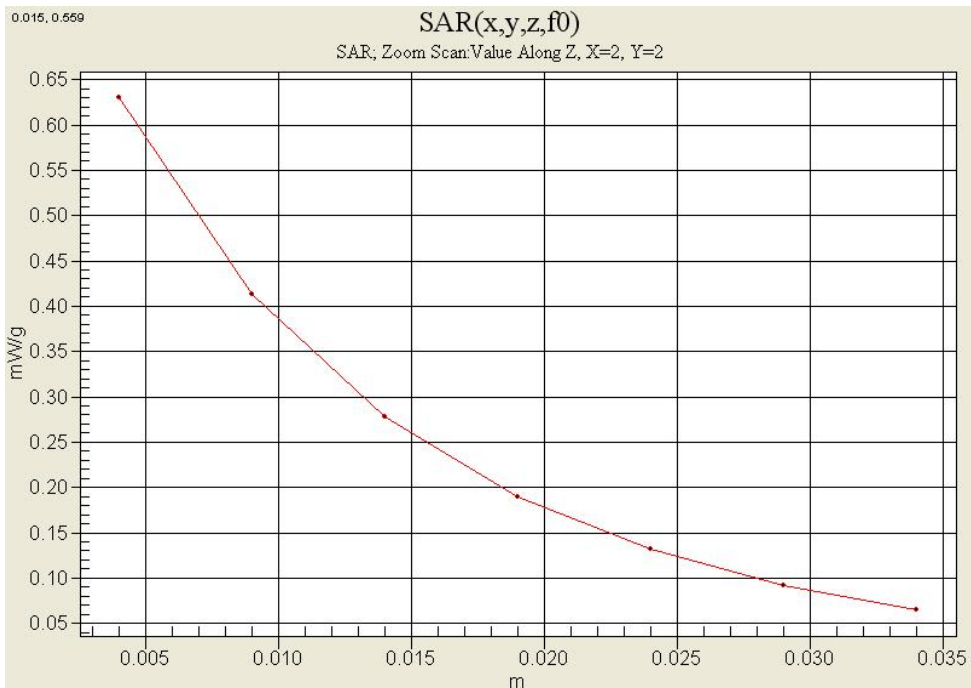

Test Laboratory: HCT CO., LTD
 EUT Type: CDMA/LTE Phone with Bluetooth & WLAN
 Liquid Temperature: 21.3 °C
 Ambient Temperature: 21.5 °C
 Test Date: Jun.08, 2011

DUT: ADR8995; Type: Bar; Serial: #1

Communication System: CDMA 835MHz FCC; Frequency: 836.52 MHz; Duty Cycle: 1:1
 Medium parameters used (interpolated): $f = 836.52 \text{ MHz}$; $\sigma = 0.982 \text{ mho/m}$; $\epsilon_r = 56.8$; $\rho = 1000 \text{ kg/m}^3$
 Phantom section: Flat Section ; Measurement SW: DASY4, V4.7 Build 71; Postprocessing SW: SEMCAD, V1.8 Build 184

DASY4 Configuration:

- Probe: ES3DV3 - SN3161; ConvF(5.86, 5.86, 5.86); Calibrated: 2011-03-17
- Sensor-Surface: 4mm (Mechanical Surface Detection)
- Electronics: DAE3 Sn466; Calibrated: 2011-03-01
- Phantom: 800/900 Phantom; Type: SAM

EVDO Body Rear 384/Area Scan (51x91x1): Measurement grid: dx=15mm, dy=15mm

[Info: Interpolated medium parameters used for SAR evaluation.](#)

Maximum value of SAR (interpolated) = 0.710 mW/g

EVDO Body Rear 384/Zoom Scan (5x5x7)/Cube 0: Measurement grid: dx=8mm, dy=8mm, dz=5mm

Reference Value = 23.3 V/m; Power Drift = 0.002 dB

Peak SAR (extrapolated) = 0.869 W/kg

SAR(1 g) = 0.670 mW/g; SAR(10 g) = 0.485 mW/g

[Info: Interpolated medium parameters used for SAR evaluation.](#)

Maximum value of SAR (measured) = 0.706 mW/g

EVDO Body Rear 384/Zoom Scan (5x5x7)/Cube 1: Measurement grid: dx=8mm, dy=8mm, dz=5mm

Reference Value = 23.3 V/m; Power Drift = 0.002 dB

Peak SAR (extrapolated) = 0.822 W/kg

SAR(1 g) = 0.585 mW/g; SAR(10 g) = 0.396 mW/g

Maximum value of SAR (measured) = 0.659 mW/g

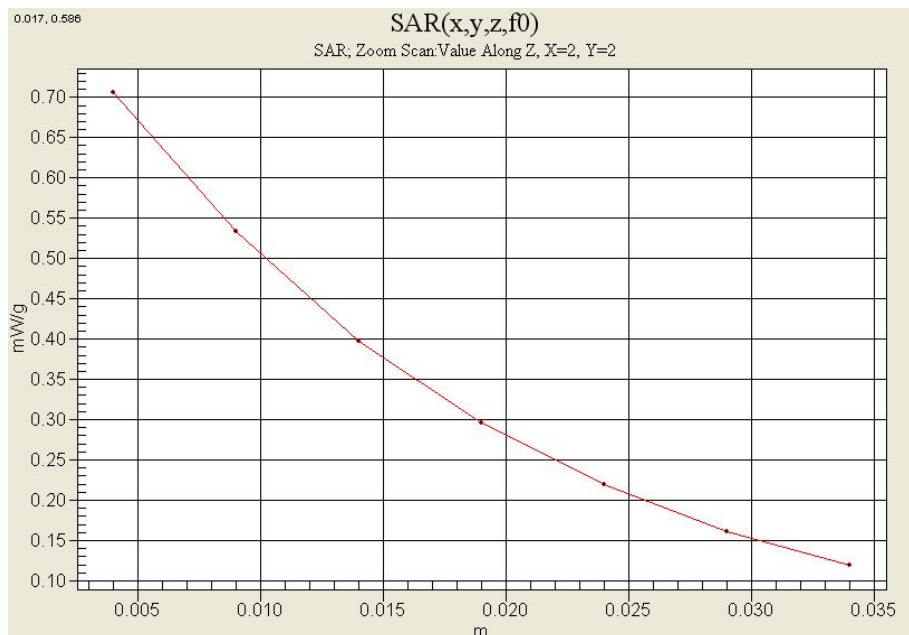

Test Laboratory: HCT CO., LTD
EUT Type: CDMA/LTE Phone with Bluetooth & WLAN
Liquid Temperature: 21.2 °C
Ambient Temperature: 21.4 °C
Test Date: Jun.08, 2011

DUT: ADR8995; Type: Bar; Serial: #1

Communication System: PCS 1900; Frequency: 1880 MHz; Duty Cycle: 1:1
Medium parameters used: $f = 1880$ MHz; $\sigma = 1.38$ mho/m; $\epsilon_r = 41.7$; $\rho = 1000$ kg/m³
Phantom section: Left Section ; Measurement SW: DASY4, V4.7 Build 71; Postprocessing SW: SEMCAD, V1.8 Build 184

DASY4 Configuration:

- Probe: ES3DV3 - SN3161; ConvF(4.91, 4.91, 4.91); Calibrated: 2011-03-17
- Sensor-Surface: 4mm (Mechanical Surface Detection)
- Electronics: DAE3 Sn466; Calibrated: 2011-03-01
- Phantom: 1800/1900 Phantom; Type: SAM

Left Tilt EVDO 600/Area Scan (51x91x1): Measurement grid: dx=15mm, dy=15mm
Maximum value of SAR (interpolated) = 1.20 mW/g

Left Tilt EVDO 600/Zoom Scan (5x5x7)/Cube 0: Measurement grid: dx=8mm, dy=8mm, dz=5mm
Reference Value = 24.1 V/m; Power Drift = 0.009 dB
Peak SAR (extrapolated) = 2.05 W/kg
SAR(1 g) = 1.05 mW/g; SAR(10 g) = 0.523 mW/g
Maximum value of SAR (measured) = 1.16 mW/g

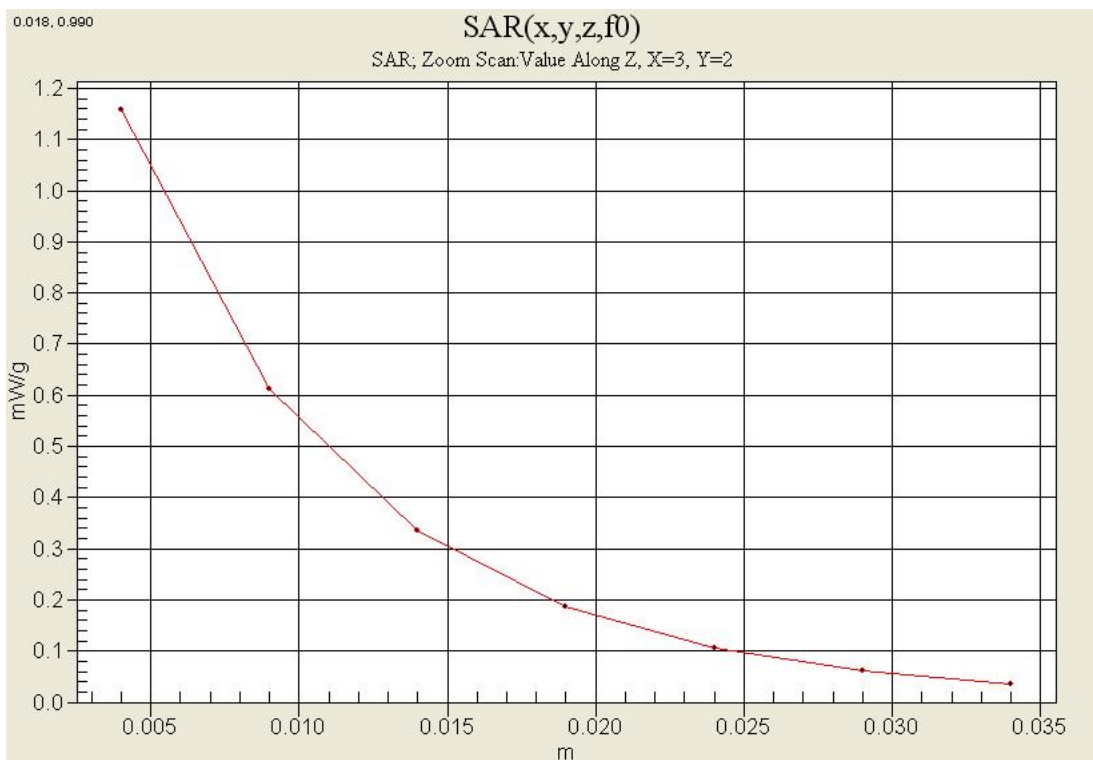

Test Laboratory: HCT CO., LTD
 EUT Type: CDMA/LTE Phone with Bluetooth & WLAN
 Liquid Temperature: 21.2 °C
 Ambient Temperature: 21.4 °C
 Test Date: Jun.09, 2011

DUT: ADR8995; Type: Bar; Serial: #1

Communication System: PCS 1900; Frequency: 1880 MHz; Duty Cycle: 1:1
 Medium parameters used: $f = 1880$ MHz; $\sigma = 1.54$ mho/m; $\epsilon_r = 52$; $\rho = 1000$ kg/m³
 Phantom section: Flat Section ; Measurement SW: DASY4, V4.7 Build 71; Postprocessing SW: SEMCAD, V1.8 Build 184

DASY4 Configuration:
 - Probe: ES3DV3 - SN3161; ConvF(4.49, 4.49, 4.49); Calibrated: 2011-03-17
 - Sensor-Surface: 4mm (Mechanical Surface Detection)
 - Electronics: DAE3 Sn466; Calibrated: 2011-03-01
 - Phantom: 1800/1900 Phantom; Type: SAM

PCS EVDO Rear 600/Area Scan (51x101x1): Measurement grid: dx=15mm, dy=15mm
 Maximum value of SAR (interpolated) = 0.907 mW/g

PCS EVDO Rear 600/Zoom Scan (5x5x7)/Cube 0: Measurement grid: dx=8mm, dy=8mm, dz=5mm
 Reference Value = 22.5 V/m; Power Drift = -0.069 dB
 Peak SAR (extrapolated) = 1.37 W/kg
SAR(1 g) = 0.797 mW/g; SAR(10 g) = 0.460 mW/g
 Maximum value of SAR (measured) = 0.865 mW/g

PCS EVDO Rear 600/Zoom Scan (5x5x7)/Cube 1: Measurement grid: dx=8mm, dy=8mm, dz=5mm
 Reference Value = 22.5 V/m; Power Drift = -0.069 dB
 Peak SAR (extrapolated) = 1.07 W/kg
 SAR(1 g) = 0.587 mW/g; SAR(10 g) = 0.350 mW/g
 Maximum value of SAR (measured) = 0.662 mW/g

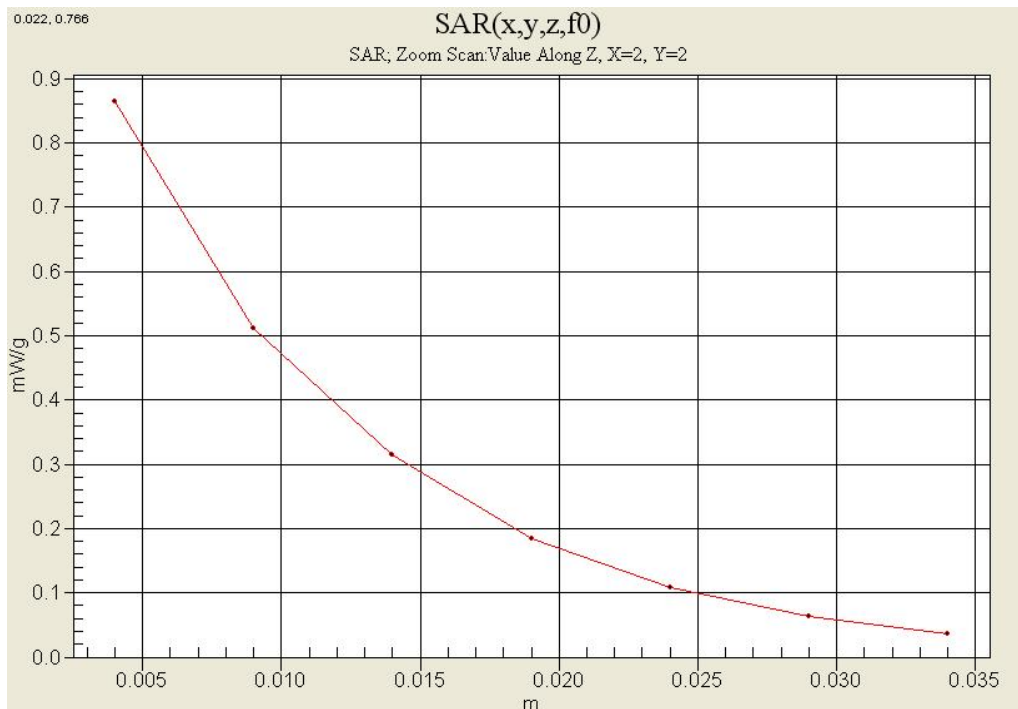

Test Laboratory: HCT CO., LTD
 EUT Type: CDMA/LTE Phone with Bluetooth & WLAN
 Liquid Temperature: 21.2 °C
 Ambient Temperature: 21.4 °C
 Test Date: Jun.10, 2011

DUT: ADR8995; Type: Bar; Serial: #1

Communication System: 2450MHz FCC; Frequency: 2437 MHz; Duty Cycle: 1:1
 Medium parameters used (interpolated): $f = 2437$ MHz; $\sigma = 1.85$ mho/m; $\epsilon_r = 38.4$; $\rho = 1000$ kg/m³
 Phantom section: Left Section ; Measurement SW: DASY4, V4.7 Build 71; Postprocessing SW: SEMCAD, V1.8 Build 184

DASY4 Configuration:
 - Probe: ES3DV3 - SN3161; ConvF(4.26, 4.26, 4.26); Calibrated: 2011-03-17
 - Sensor-Surface: 4mm (Mechanical Surface Detection)
 - Electronics: DAE3 Sn466; Calibrated: 2011-03-01
 - Phantom: 1800/1900 Phantom; Type: SAM

Left Touch 6ch/Area Scan (61x91x1): Measurement grid: dx=15mm, dy=15mm

[Info: Interpolated medium parameters used for SAR evaluation.](#)

Maximum value of SAR (interpolated) = 0.294 mW/g

Left Touch 6ch/Zoom Scan (5x5x7)/Cube 0: Measurement grid: dx=8mm, dy=8mm, dz=5mm

Reference Value = 6.20 V/m; Power Drift = -0.350 dB

Peak SAR (extrapolated) = 0.660 W/kg

SAR(1 g) = 0.261 mW/g; SAR(10 g) = 0.113 mW/g

[Info: Interpolated medium parameters used for SAR evaluation.](#)

Maximum value of SAR (measured) = 0.293 mW/g

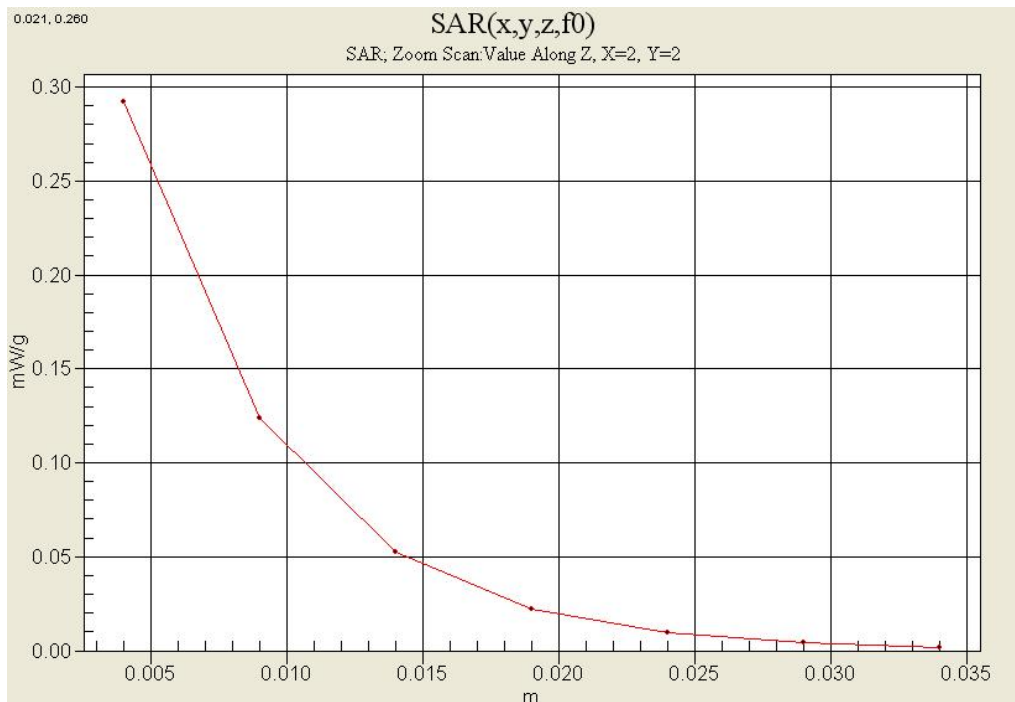

Test Laboratory: HCT CO., LTD
 EUT Type: CDMA/LTE Phone with Bluetooth & WLAN
 Liquid Temperature: 21.2 °C
 Ambient Temperature: 21.4 °C
 Test Date: Jun.10, 2011

DUT: ADR8995; Type: Bar; Serial: #1

Communication System: 2450MHz FCC; Frequency: 2437 MHz;Duty Cycle: 1:1
 Medium parameters used (interpolated): $f = 2437$ MHz; $\sigma = 1.94$ mho/m; $\epsilon_r = 51.6$; $\rho = 1000$ kg/m³
 Phantom section: Flat Section ; Measurement SW: DASY4, V4.7 Build 71; Postprocessing SW: SEMCAD, V1.8 Build 184

DASY4 Configuration:
 - Probe: ES3DV3 - SN3161; ConvF(4.03, 4.03, 4.03); Calibrated: 2011-03-17
 - Sensor-Surface: 4mm (Mechanical Surface Detection)
 - Electronics: DAE3 Sn466; Calibrated: 2011-03-01
 - Phantom: 1800/1900 Phantom; Type: SAM

802,11b Hotspot Right side 6ch/Area Scan (41x101x1): Measurement grid: dx=15mm, dy=15mm

[Info: Interpolated medium parameters used for SAR evaluation.](#)

Maximum value of SAR (interpolated) = 0.097 mW/g

802,11b Hotspot Right side 6ch/Zoom Scan (5x5x7)/Cube 0: Measurement grid: dx=8mm, dy=8mm, dz=5mm

Reference Value = 7.01 V/m; Power Drift = -0.027 dB

Peak SAR (extrapolated) = 0.190 W/kg

SAR(1 g) = 0.089 mW/g; SAR(10 g) = 0.037 mW/g

[Info: Interpolated medium parameters used for SAR evaluation.](#)

Maximum value of SAR (measured) = 0.096 mW/g

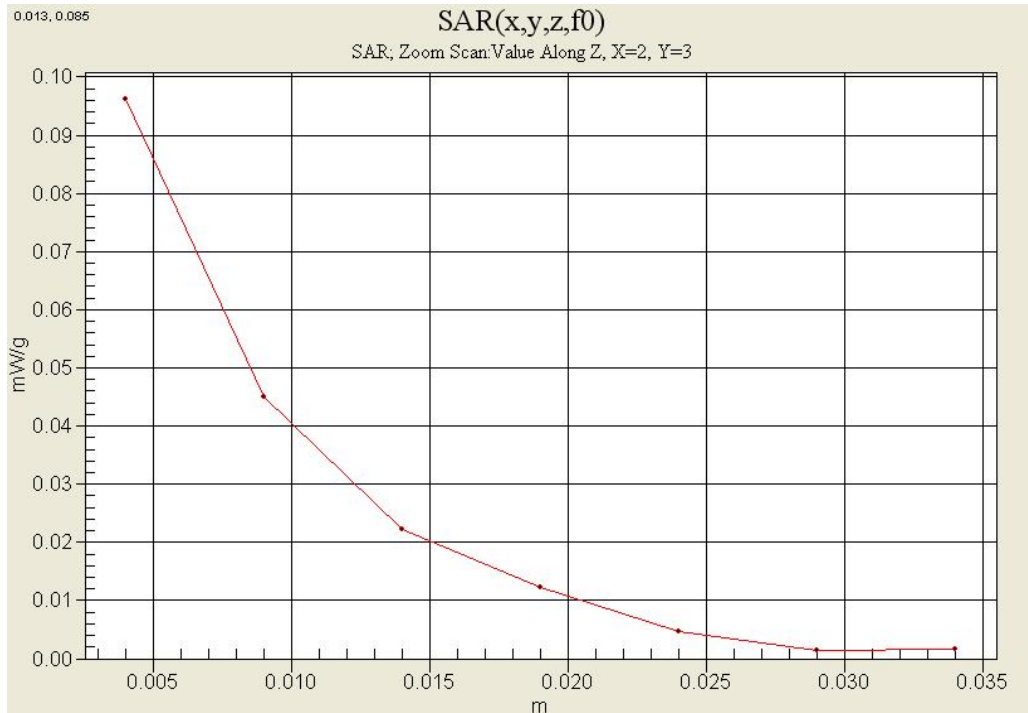

Test Laboratory: HCT CO., LTD
 EUT Type: CDMA/LTE Phone with Bluetooth & WLAN
 Liquid Temperature: 21.2 °C
 Ambient Temperature: 21.4 °C
 Test Date: May.06, 2011

DUT: ADR8995; Type: Bar; Serial: #1

Communication System: LTE; Frequency: 782 MHz; Duty Cycle: 1:1
 Medium parameters used: $f = 782.5$ MHz; $\sigma = 0.893$ mho/m; $\epsilon_r = 41.7$; $\rho = 1000$ kg/m³
 Phantom section: Left Section ; Measurement SW: DASY4, V4.7 Build 71; Postprocessing SW: SEMCAD, V1.8 Build 184

DASY4 Configuration:

- Probe: ES3DV3 - SN3161; ConvF(6.1, 6.1, 6.1); Calibrated: 2011-03-17
- Sensor-Surface: 4mm (Mechanical Surface Detection)
- Electronics: DAE3 Sn466; Calibrated: 2011-03-01
- Phantom: 835/900 Phantom ; Type: SAM

Left Touch 23230 QPSK 1 49/Area Scan (51x91x1): Measurement grid: dx=15mm, dy=15mm
 MMaximum value of SAR (interpolated) = 0.373 mW/g

Left Touch 23230 QPSK 1 49/Zoom Scan (5x5x7)/Cube 0: Measurement grid: dx=8mm, dy=8mm, dz=5mm
 Reference Value = 18.7 V/m; Power Drift = 0.080 dB
 Peak SAR (extrapolated) = 0.495 W/kg
SAR(1 g) = 0.321 mW/g; SAR(10 g) = 0.225 mW/g
 Maximum value of SAR (measured) = 0.336 mW/g

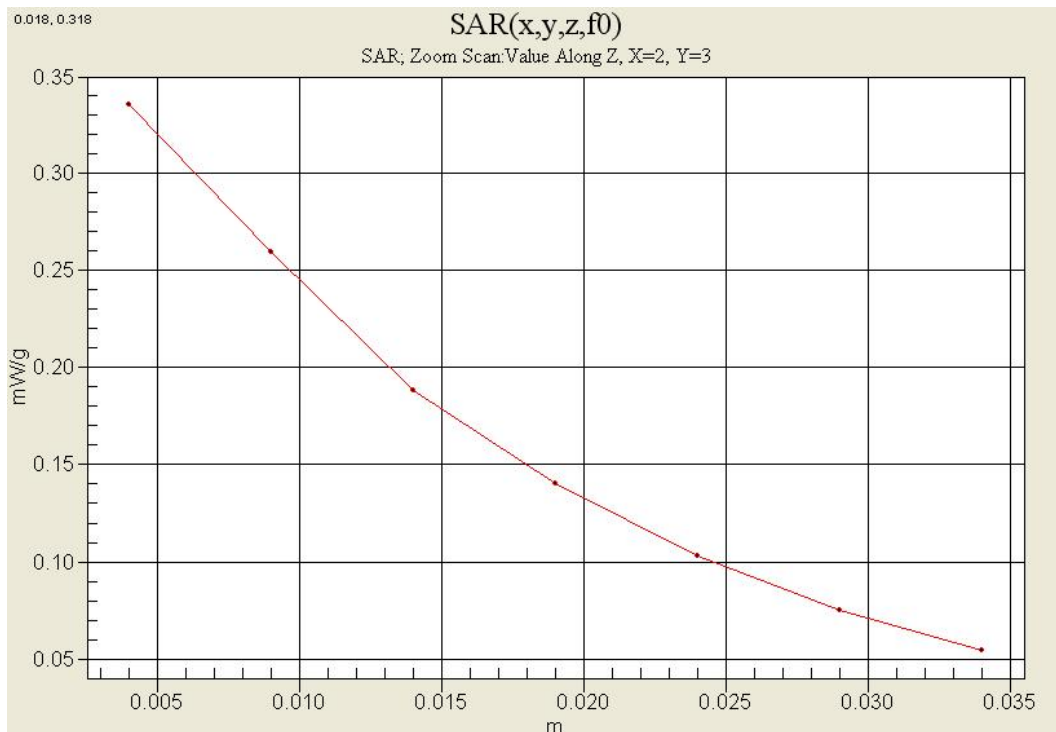

Test Laboratory: HCT CO., LTD
 EUT Type: CDMA/LTE Phone with Bluetooth & WLAN
 Liquid Temperature: 21.3 °C
 Ambient Temperature: 21.5 °C
 Test Date: May.09, 2011

DUT: ADR8995; Type: Bar; Serial: #1

Communication System: LTE; Frequency: 782 MHz; Duty Cycle: 1:1
 Medium parameters used (interpolated): $f = 782 \text{ MHz}$; $\sigma = 1 \text{ mho/m}$; $\epsilon_r = 54.2$; $\rho = 1000 \text{ kg/m}^3$
 Phantom section: Flat Section ; Measurement SW: DASY4, V4.7 Build 71; Postprocessing SW: SEMCAD, V1.8 Build 184

DASY4 Configuration:
 - Probe: ES3DV3 - SN3161; ConvF(5.93, 5.93, 5.93); Calibrated: 2011-03-17
 - Sensor-Surface: 4mm (Mechanical Surface Detection)
 - Electronics: DAE3 Sn466; Calibrated: 2011-03-01
 - Phantom: 800/900 Phantom; Type: SAM

LTE Body Rear QPSK 1 49 23230/Area Scan (51x91x1): Measurement grid: dx=15mm, dy=15mm

[Info: Interpolated medium parameters used for SAR evaluation.](#)

Maximum value of SAR (interpolated) = 0.471 mW/g

LTE Body Rear QPSK 1 49 23230/Zoom Scan (5x5x7)/Cube 0: Measurement grid: dx=8mm, dy=8mm, dz=5mm

Reference Value = 19.4 V/m; Power Drift = -0.046 dB

Peak SAR (extrapolated) = 0.565 W/kg

SAR(1 g) = 0.442 mW/g; SAR(10 g) = 0.326 mW/g

[Info: Interpolated medium parameters used for SAR evaluation.](#)

Maximum value of SAR (measured) = 0.467 mW/g

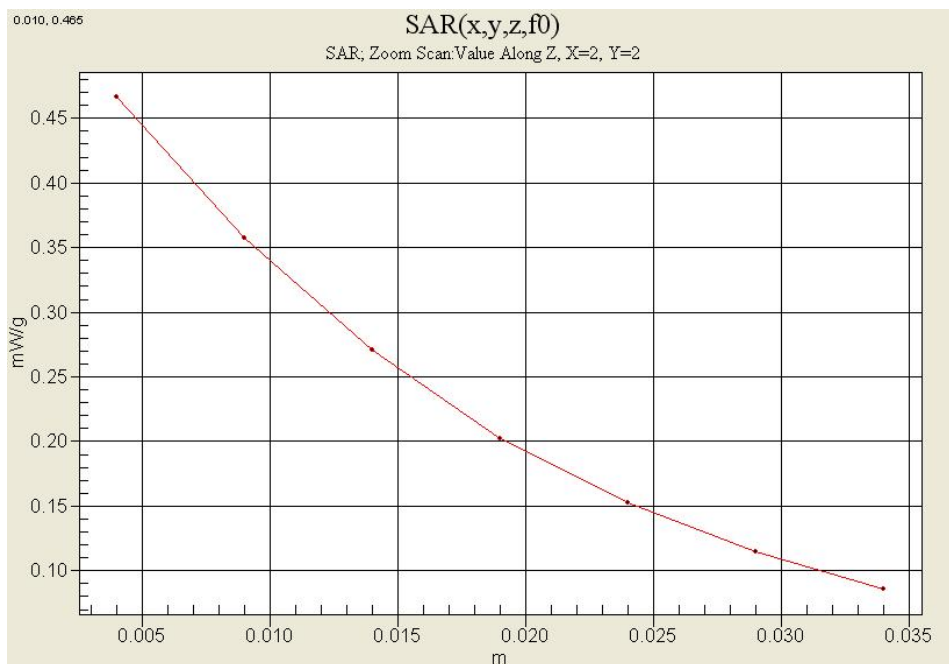

Attachment 2. – Dipole Validation Plots

■ Validation Data (835 MHz Head)

Test Laboratory: HCT CO., LTD
Input Power 100 mW (20 dBm)
Liquid Temp: 21.3 °C
Test Date: Jun.08, 2011

DUT: Dipole 835 MHz; Type: D835V2; Serial: D835V2 – SN:441

Communication System: CW; Frequency: 835 MHz; Duty Cycle: 1:1
Medium parameters used: $f = 835$ MHz; $\sigma = 0.887$ mho/m; $\epsilon_r = 41.4$; $\rho = 1000$ kg/m³
Phantom section: Flat Section ; Measurement SW: DASY4, V4.7 Build 71; Postprocessing SW: SEMCAD, V1.8 Build 184

DASY4 Configuration:

- Probe: ES3DV3 – SN3161; ConvF(5.84, 5.84, 5.84); Calibrated: 2011-03-17
- Sensor-Surface: 4mm (Mechanical Surface Detection)
- Electronics: DAE3 Sn466; Calibrated: 2011-03-01
- Phantom: SAM 835/900 MHz; Type: SAM

Validation 835 MHz/Area Scan (61x81x1): Measurement grid: dx=15mm, dy=15mm
Maximum value of SAR (interpolated) = 1.06 mW/g

Validation 835 MHz/Zoom Scan (5x5x7)/Cube 0: Measurement grid: dx=8mm, dy=8mm, dz=5mm
Reference Value = 34.7 V/m; Power Drift = 0.002 dB
Peak SAR (extrapolated) = 1.40 W/kg
SAR(1 g) = 0.961 mW/g; SAR(10 g) = 0.639 mW/g
Maximum value of SAR (measured) = 1.04 mW/g

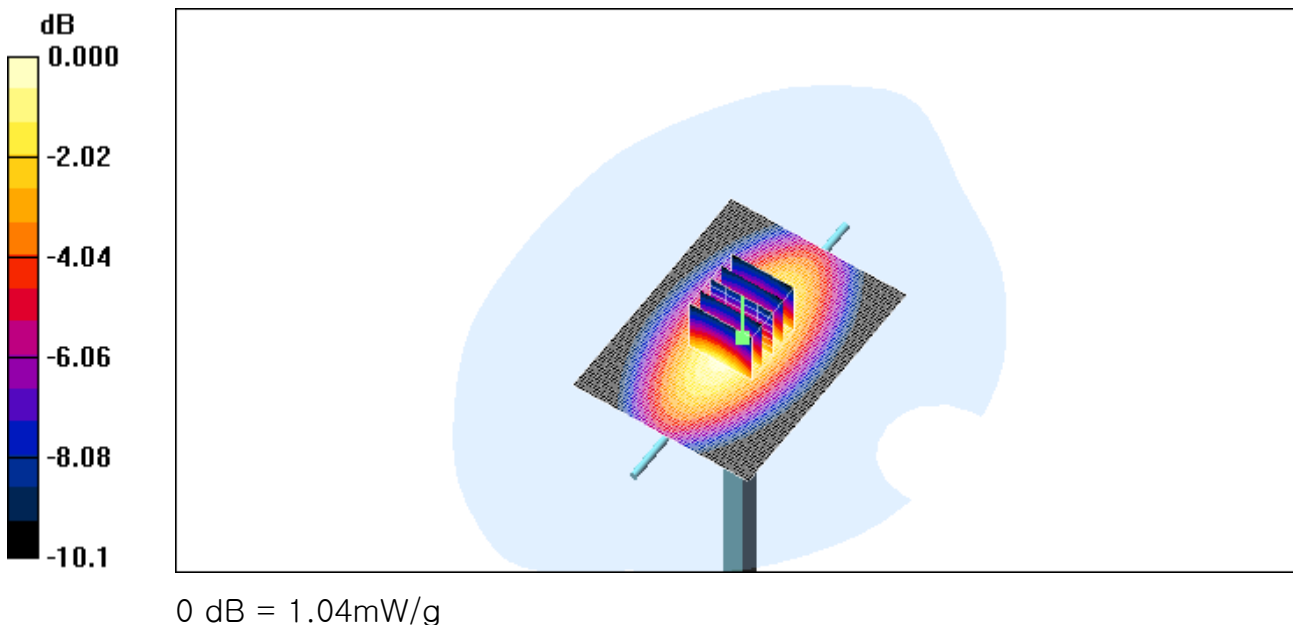

■ Validation Data (835 MHz Body)

Test Laboratory: HCT CO., LTD
Input Power: 100 mW (20 dBm)
Liquid Temp: 21.3 °C
Test Date: Jun.08, 2011

DUT: Dipole 835 MHz; Type: D835V2; Serial: D835V2 – SN:441

Communication System: CW; Frequency: 835 MHz; Duty Cycle: 1:1
Medium parameters used: $f = 835$ MHz; $\sigma = 0.981$ mho/m; $\epsilon_r = 56.9$; $\rho = 1000$ kg/m³
Phantom section: Flat Section ; Measurement SW: DASY4, V4.7 Build 71; Postprocessing SW: SEMCAD, V1.8 Build 184

DASY4 Configuration:

- Probe: ES3DV3 – SN3161; ConvF(5.86, 5.86, 5.86); Calibrated: 2011-03-17
- Sensor-Surface: 4mm (Mechanical Surface Detection)
- Electronics: DAE3 Sn466; Calibrated: 2011-03-01
- Phantom: 835/900 Phantom ; Type: SAM

Validation 835 MHz/Area Scan (61x81x1): Measurement grid: dx=15mm, dy=15mm
Maximum value of SAR (interpolated) = 1.08 mW/g

Validation 835 MHz/Zoom Scan (5x5x7)/Cube 0: Measurement grid: dx=8mm, dy=8mm, dz=5mm
Reference Value = 33.8 V/m; Power Drift = -0.057 dB
Peak SAR (extrapolated) = 1.49 W/kg
SAR(1 g) = 1.01 mW/g; SAR(10 g) = 0.659 mW/g
Maximum value of SAR (measured) = 1.08 mW/g

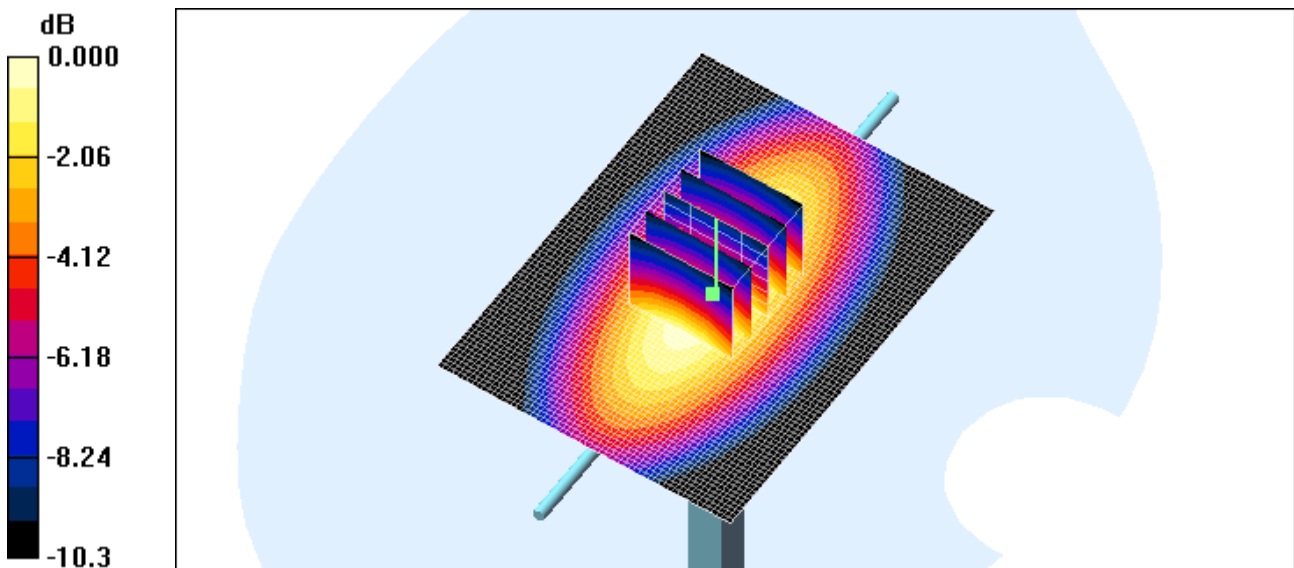

0 dB = 1.08mW/g

■ Validation Data (1900 MHz Head)

Test Laboratory: HCT CO., LTD
Input Power: 100 mW (20 dBm)
Liquid Temp: 21.2 °C
Test Date: Jun.09, 2011

DUT: Dipole 1900 MHz; Type: D1900V2; Serial: D1900V2 – SN:5d032

Communication System: CW; Frequency: 1900 MHz; Duty Cycle: 1:1
Medium parameters used: $f = 1900$ MHz; $\sigma = 1.4$ mho/m; $\epsilon_r = 41.5$; $\rho = 1000$ kg/m³
Phantom section: Flat Section ; Measurement SW: DASY4, V4.7 Build 71; Postprocessing SW: SEMCAD, V1.8 Build 184

DASY4 Configuration:

- Probe: ES3DV3 – SN3161; ConvF(4.91, 4.91, 4.91); Calibrated: 2011-03-17
- Sensor-Surface: 4mm (Mechanical Surface Detection)
- Electronics: DAE3 Sn466; Calibrated: 2011-03-01
- Phantom: SAM 1800/1900 MHz; Type: SAM

Dipole 1900MHz Validation/Area Scan (61x61x1): Measurement grid: dx=15mm, dy=15mm
Maximum value of SAR (interpolated) = 4.59 mW/g

Dipole 1900MHz Validation/Zoom Scan (5x5x7)/Cube 0: Measurement grid: dx=8mm, dy=8mm, dz=5mm
Reference Value = 57.5 V/m; Power Drift = 0.009 dB
Peak SAR (extrapolated) = 7.36 W/kg
SAR(1 g) = 4.09 mW/g; SAR(10 g) = 2.22 mW/g
Maximum value of SAR (measured) = 4.40 mW/g

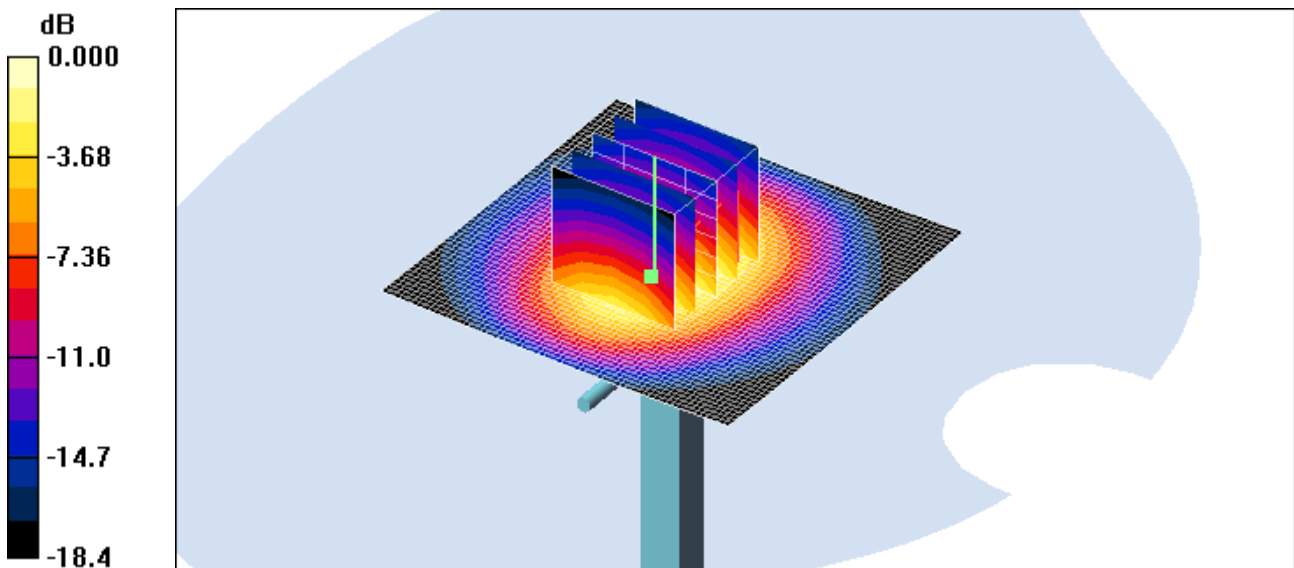

0 dB = 4.40mW/g

■ Validation Data (1900 MHz Body)

Test Laboratory: HCT CO., LTD
Input Power: 100 mW (20 dBm)
Liquid Temp: 21.2 °C
Test Date: Jun.09, 2011

DUT: Dipole 1900 MHz; Type: D1900V2; Serial: D1900V2 – SN:5d032

Communication System: CW; Frequency: 1900 MHz; Duty Cycle: 1:1
Medium parameters used: $f = 1900$ MHz; $\sigma = 1.56$ mho/m; $\epsilon_r = 52$; $\rho = 1000$ kg/m³
Phantom section: Flat Section ; Measurement SW: DASY4, V4.7 Build 71; Postprocessing SW: SEMCAD, V1.8 Build 184

DASY4 Configuration:

- Probe: ES3DV3 – SN3161; ConvF(4.49, 4.49, 4.49); Calibrated: 2011-03-17
- Sensor-Surface: 4mm (Mechanical Surface Detection)
- Electronics: DAE3 Sn466; Calibrated: 2011-03-01
- Phantom: SAM 1800/1900 MHz; Type: SAM

Dipole 1900MHz Validation/Area Scan (61x61x1): Measurement grid: dx=15mm, dy=15mm
Maximum value of SAR (interpolated) = 4.76 mW/g

Dipole 1900MHz Validation/Zoom Scan (5x5x7)/Cube 0: Measurement grid: dx=8mm, dy=8mm, dz=5mm
Reference Value = 54.7 V/m; Power Drift = -0.004 dB
Peak SAR (extrapolated) = 8.03 W/kg
SAR(1 g) = 4.1 mW/g; SAR(10 g) = 2.03 mW/g
Maximum value of SAR (measured) = 4.59 mW/g

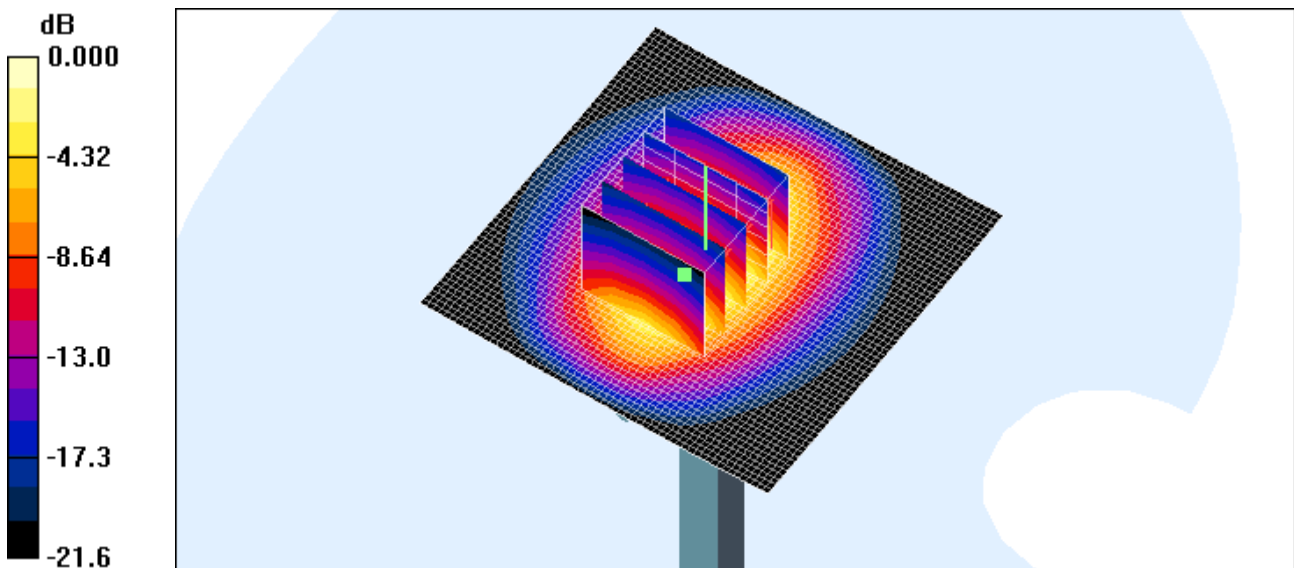

0 dB = 4.59mW/g

Validation Data (750 MHz Head)

Test Laboratory: HCT CO., LTD
 Input Power 100 mW (20 dBm)
 Liquid Temp: 21.2 °C
 Test Date: May.06, 2011

DUT: Dipole 750 MHz; Type: D750V3; Serial: D750V3 – SN:1014

Communication System: CW; Frequency: 750 MHz; Duty Cycle: 1:1
 Medium parameters used: $f = 750 \text{ MHz}$; $\sigma = 0.866 \text{ mho/m}$; $\epsilon_r = 42.2$; $\rho = 1000 \text{ kg/m}^3$
 Phantom section: Flat Section ; Measurement SW: DASY4, V4.7 Build 71; Postprocessing SW: SEMCAD, V1.8 Build 184

DASY4 Configuration:
 - Probe: ES3DV3 – SN3161; ConvF(6.1, 6.1, 6.1); Calibrated: 2011-03-17
 - Sensor-Surface: 4mm (Mechanical Surface Detection)
 - Electronics: DAE3 Sn466; Calibrated: 2011-03-01
 - Phantom: SAM 835/900 MHz; Type: SAM

Validation 750 MHz/Area Scan (61x81x1): Measurement grid: dx=15mm, dy=15mm
 Maximum value of SAR (interpolated) = 0.899 mW/g

Validation 750 MHz/Zoom Scan (5x5x7)/Cube 0: Measurement grid: dx=8mm, dy=8mm, dz=5mm
 Reference Value = 32.6 V/m; Power Drift = 0.011 dB
 Peak SAR (extrapolated) = 1.25 W/kg
SAR(1 g) = 0.832 mW/g; SAR(10 g) = 0.547 mW/g
 Maximum value of SAR (measured) = 0.897 mW/g

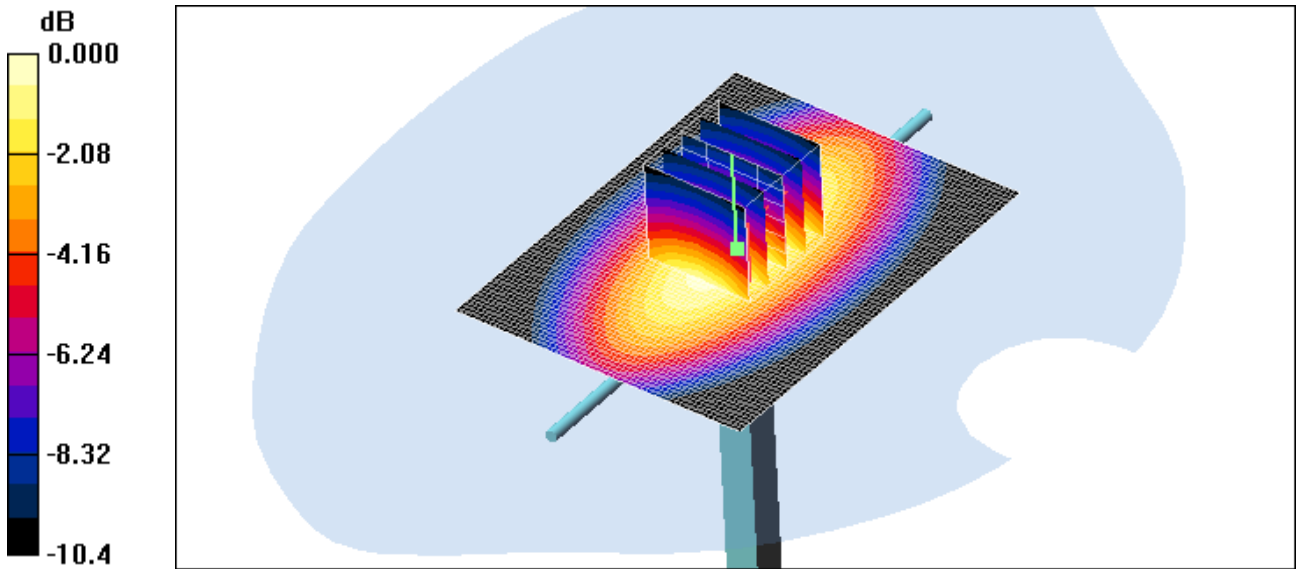

0 dB = 0.897mW/g

Validation Data (750 MHz Body)

Test Laboratory: HCT CO., LTD
 Input Power: 100 mW (20 dBm)
 Liquid Temp: 21.3 °C
 Test Date: May.09, 2011

DUT: Dipole 750 MHz; Type: D750V3; Serial: D750V3 – SN:1014

Communication System: CW; Frequency: 750 MHz; Duty Cycle: 1:1
 Medium parameters used: $f = 750 \text{ MHz}$; $\sigma = 0.973 \text{ mho/m}$; $\epsilon_r = 54.7$; $\rho = 1000 \text{ kg/m}^3$
 Phantom section: Flat Section ; Measurement SW: DASY4, V4.7 Build 71; Postprocessing SW: SEMCAD, V1.8 Build 184

DASY4 Configuration:
 - Probe: ES3DV3 – SN3161; ConvF(5.93, 5.93, 5.93); Calibrated: 2011-03-17
 - Sensor-Surface: 4mm (Mechanical Surface Detection)
 - Electronics: DAE3 Sn466; Calibrated: 2011-03-01
 - Phantom: 835/900 Phamtom ; Type: SAM

Validation 750 MHz/Area Scan (61x81x1): Measurement grid: dx=15mm, dy=15mm
 Maximum value of SAR (interpolated) = 0.981 mW/g

Validation 750 MHz/Zoom Scan (5x5x7)/Cube 0: Measurement grid: dx=8mm, dy=8mm, dz=5mm
 Reference Value = 32.6 V/m; Power Drift = -0.024 dB
 Peak SAR (extrapolated) = 1.33 W/kg
SAR(1 g) = 0.893 mW/g; SAR(10 g) = 0.586 mW/g
 Maximum value of SAR (measured) = 0.962 mW/g

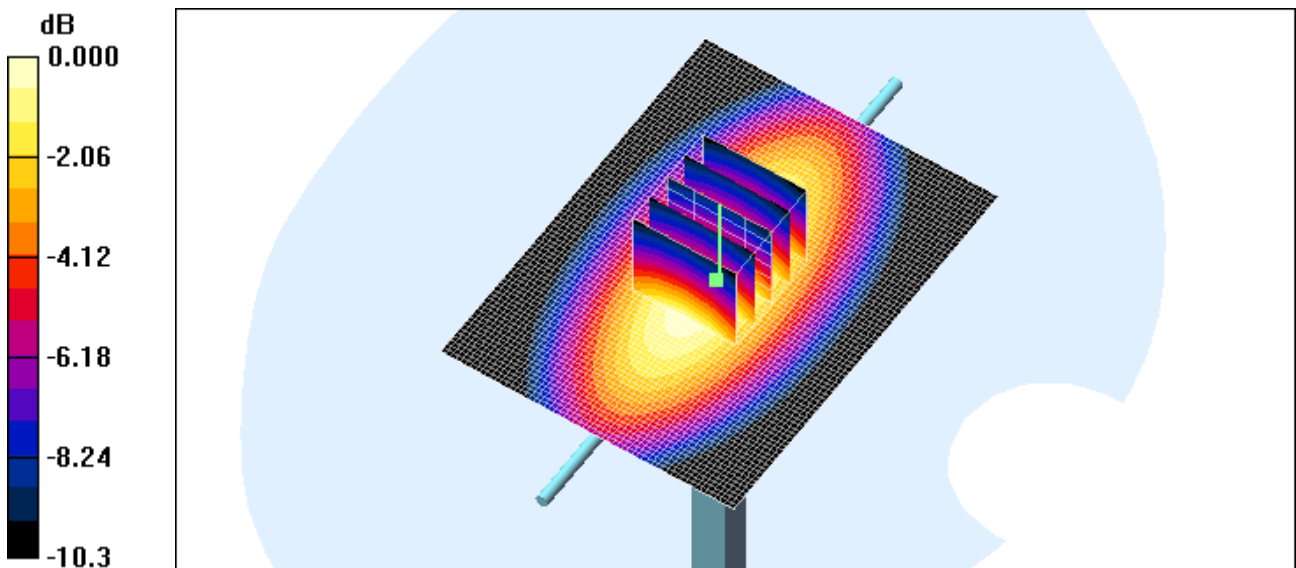

0 dB = 0.962mW/g

■ Validation Data (2450 MHz Head)

Test Laboratory: HCT CO., LTD
Input Power: 100 mW (20 dBm)
Liquid Temp: 21.2 °C
Test Date: Jun.10, 2011

DUT: Dipole 2450 MHz; Type: D2450V2; Serial: D2450V2 – SN:743

Communication System: CW; Frequency: 2450 MHz; Duty Cycle: 1:1
Medium parameters used: $f = 2450$ MHz; $\sigma = 1.84$ mho/m; $\epsilon_r = 39.7$; $\rho = 1000$ kg/m³
Phantom section: Flat Section ; Measurement SW: DASY4, V4.7 Build 71; Postprocessing SW: SEMCAD, V1.8 Build 184

DASY4 Configuration:

- Probe: ES3DV3 – SN3161; ConvF(4.26, 4.26, 4.26); Calibrated: 2011-03-17
- Sensor-Surface: 4mm (Mechanical Surface Detection)
- Electronics: DAE3 Sn466; Calibrated: 2011-03-01
- Phantom: SAM 1800/1900 MHz; Type: SAM

Validation 2450MHz/Area Scan (61x61x1): Measurement grid: dx=15mm, dy=15mm
Maximum value of SAR (interpolated) = 6.51 mW/g

Validation 2450MHz/Zoom Scan (5x5x7)/Cube 0: Measurement grid: dx=8mm, dy=8mm, dz=5mm
Reference Value = 56.7 V/m; Power Drift = 0.012 dB
Peak SAR (extrapolated) = 13.9 W/kg
SAR(1 g) = 5.48 mW/g; SAR(10 g) = 2.42 mW/g
Maximum value of SAR (measured) = 5.95 mW/g

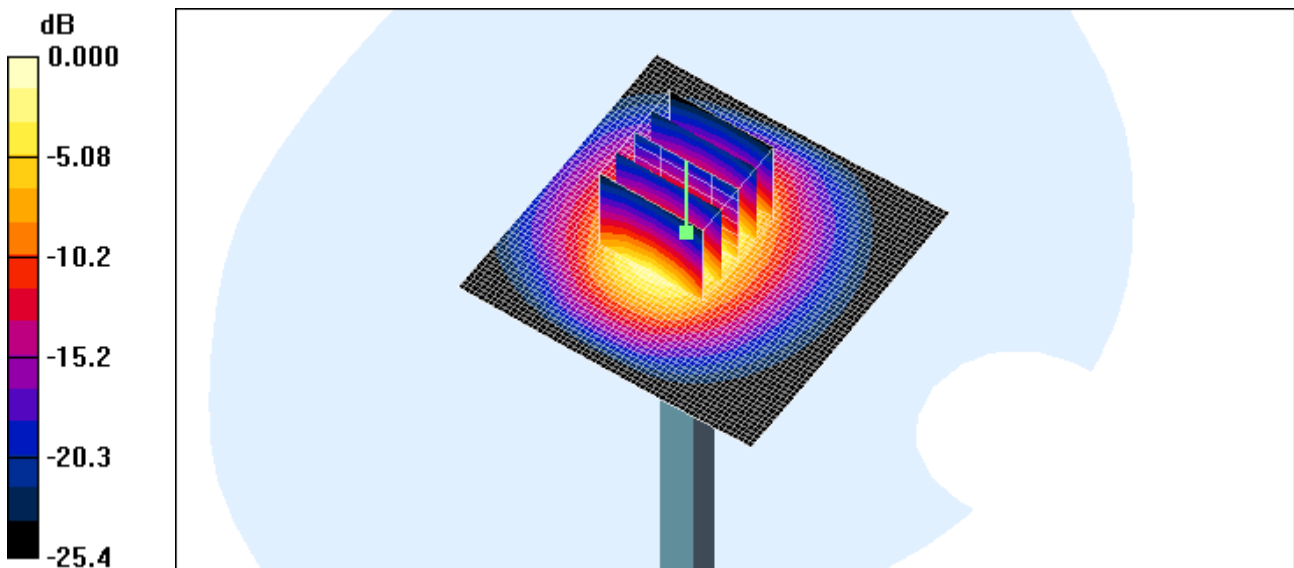

0 dB = 5.95mW/g

■ Validation Data (2450 MHz Body)

Test Laboratory: HCT CO., LTD
Input Power: 100 mW (20 dBm)
Liquid Temp: 21.2 °C
Test Date: Jun.10, 2011

DUT: Dipole 2450 MHz; Type: D2450V2; Serial: D2450V2 – SN:743

Communication System: CW; Frequency: 2450 MHz; Duty Cycle: 1:1
Medium parameters used: $f = 2450$ MHz; $\sigma = 1.96$ mho/m; $\epsilon_r = 51.6$; $\rho = 1000$ kg/m³
Phantom section: Flat Section ; Measurement SW: DASY4, V4.7 Build 71; Postprocessing SW: SEMCAD, V1.8 Build 184

DASY4 Configuration:

- Probe: ES3DV3 – SN3161; ConvF(4.03, 4.03, 4.03); Calibrated: 2011-03-17
- Sensor-Surface: 4mm (Mechanical Surface Detection)
- Electronics: DAE3 Sn466; Calibrated: 2011-03-01
- Phantom: 1800/1900 Phantom; Type: SAM

Validation 2450MHz/Area Scan (61x61x1): Measurement grid: dx=15mm, dy=15mm
Maximum value of SAR (interpolated) = 6.72 mW/g

Validation 2450MHz/Zoom Scan (5x5x7)/Cube 0: Measurement grid: dx=8mm, dy=8mm, dz=5mm
Reference Value = 49.6 V/m; Power Drift = -0.229 dB
Peak SAR (extrapolated) = 12.2 W/kg
SAR(1 g) = 5.41 mW/g; SAR(10 g) = 2.42 mW/g
Maximum value of SAR (measured) = 5.98 mW/g

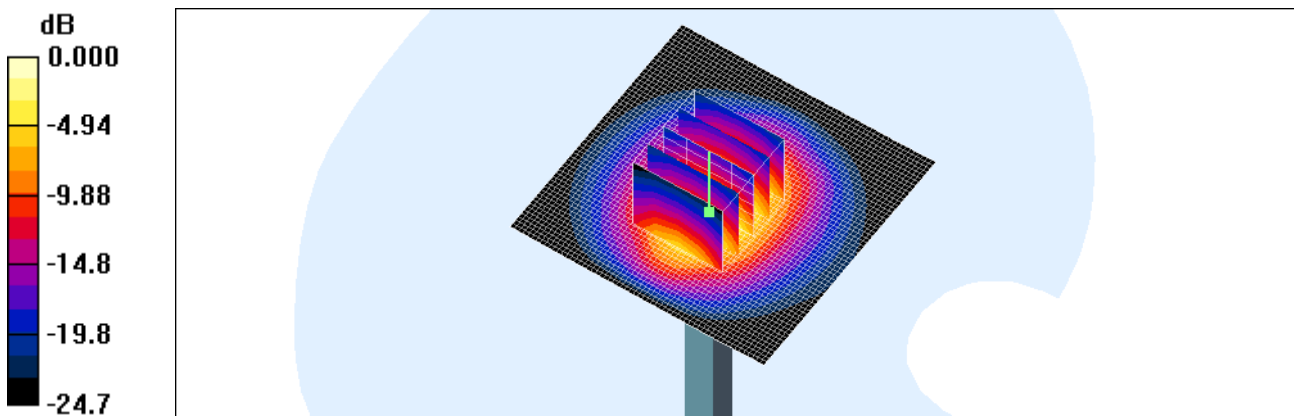

0 dB = 5.98mW/g

■ Dielectric Parameter (835 MHz Head)

Title ADR8995
SubTitle CDMA850(Head)
Test Date Jun.08, 2011

Frequency	e'	e''
800000000	41.7904	19.1440
805000000	41.7370	19.1091
810000000	41.6727	19.1099
815000000	41.5913	19.0835
820000000	41.5689	19.0733
825000000	41.5040	19.0802
830000000	41.4533	19.1149
835000000	41.4379	19.1028
840000000	41.3849	19.1222
845000000	41.3124	19.1054
850000000	41.2997	19.1135
855000000	41.2440	19.1130
860000000	41.2082	19.1070
865000000	41.1731	19.1009
870000000	41.1279	19.0927
875000000	41.0816	19.0951
880000000	41.0486	19.0535
885000000	40.9940	19.0736
890000000	40.9206	19.0095
895000000	40.8681	18.9797
900000000	40.7873	18.9687

■ Dielectric Parameter (835 MHz Body)

Title ADR8995
SubTitle CDMA 850(Body)
Test Date Jun.08, 2011

Frequency	e'	e''
800000000	57.0357	21.3263
805000000	56.9736	21.2577
810000000	56.9573	21.2205
815000000	56.8890	21.2209
820000000	56.9434	21.1914
825000000	56.8657	21.1609
830000000	56.8649	21.1023
835000000	56.8505	21.1240
840000000	56.7830	21.0802
845000000	56.6787	21.0487
850000000	56.7232	20.9837
855000000	56.6057	20.9479
860000000	56.5566	20.8963
865000000	56.4590	20.9133
870000000	56.3304	20.8424
875000000	56.2854	20.8218
880000000	56.2146	20.7549
885000000	56.1522	20.7454
890000000	56.1258	20.7503
895000000	56.0560	20.7679
900000000	56.0765	20.7148

■ Dielectric Parameter (1900 MHz Head)

Title ADR8995
 SubTitle PCS1900(Head)
 Test Date Jun.09, 2011

Frequency	e'	e''
1800000000	41.9725	12.9200
1810000000	41.9233	12.9214
1820000000	41.9082	13.0058
1830000000	41.8979	13.0435
1840000000	41.8963	13.1061
1850000000	41.8373	13.0987
1860000000	41.7879	13.1038
1870000000	41.7593	13.1381
1880000000	41.6725	13.1658
1890000000	41.6458	13.1990
1900000000	41.5404	13.2219
1910000000	41.5171	13.2470
1920000000	41.4437	13.2945
1930000000	41.4383	13.3287
1940000000	41.4324	13.3602
1950000000	41.4310	13.3792
1960000000	41.4303	13.3976
1970000000	41.4248	13.4163
1980000000	41.3595	13.4381
1990000000	41.3430	13.4465
2000000000	41.2770	13.4724

■ Dielectric Parameter (1900 MHz Body)

Title ADR8995
SubTitle PCS1900(Body)
Test Date Jun.09, 2011

Frequency	e'	e''
v	52.1169	14.6202
1855000000	52.0994	14.6398
1860000000	52.1044	14.6722
1865000000	52.0877	14.6588
1870000000	52.0736	14.7297
1875000000	52.0637	14.7067
1880000000	52.0465	14.7156
1885000000	52.0582	14.7527
1890000000	52.0176	14.7466
1895000000	52.0097	14.7725
1900000000	51.9904	14.7691
1905000000	51.9980	14.7991
1910000000	51.9838	14.8165
1915000000	51.9669	14.8183
1920000000	51.9662	14.8415
1925000000	51.9364	14.8480
1930000000	51.9173	14.8736
1935000000	51.9178	14.8886
1940000000	51.8925	14.8985
1945000000	51.9071	14.9006
1950000000	51.8721	14.9341

■ Dielectric Parameter (750 MHz Head)

Title ADR8995
SubTitle 750MHz (Head)
Test Date May.05, 2011

Frequency	e'	e''
750000000	42.1995	20.7500
752500000	42.1622	20.7236
755000000	42.0928	20.7057
757500000	42.1008	20.6967
760000000	42.0426	20.6305
762500000	42.0122	20.6488
765000000	41.9978	20.6174
767500000	41.9398	20.6145
770000000	41.8954	20.5969
772500000	41.8738	20.5791
775000000	41.8408	20.5813
777500000	41.7932	20.5481
780000000	41.7856	20.5383
782500000	41.7413	20.5158
785000000	41.7160	20.5218
787500000	41.6827	20.4967
790000000	41.6552	20.4924
792500000	41.6300	20.4544
795000000	41.6262	20.4549
797500000	41.6048	20.4711
800000000	41.5414	20.4109

■ Dielectric Parameter (750 MHz Body)

Title ADR8995
SubTitle 750MHz (Body)
Test Date May.09, 2011

Frequency	e'	e''
700000000	55.4198	23.7872
705000000	55.3337	23.6480
710000000	55.2805	23.6895
715000000	55.2114	23.6164
720000000	55.1412	23.5946
725000000	55.0469	23.5126
730000000	54.9874	23.4576
735000000	54.8959	23.4138
740000000	54.8095	23.3996
745000000	54.7558	23.3872
750000000	54.6654	23.3147
755000000	54.5874	23.2571
760000000	54.5125	23.2233
765000000	54.4674	23.1146
770000000	54.4092	23.0884
775000000	54.3118	23.0641
780000000	54.2690	23.0920
785000000	54.1915	23.0151
790000000	54.1540	22.9833
795000000	54.0306	22.9009
800000000	53.9877	22.8147

■ Dielectric Parameter (2450 MHz Head)

Title ADR8995
SubTitle 2450MHz (Head)
Test Date Jun.10, 2011

Frequency	e'	e''
2400000000.0000	38.2438	13.5443
2405000000.0000	38.2133	13.5598
2410000000.0000	38.2014	13.5741
2415000000.0000	38.1599	13.5822
2420000000.0000	38.1471	13.6083
2425000000.0000	38.1172	13.6099
2430000000.0000	38.1060	13.6239
2435000000.0000	38.0877	13.6190
2440000000.0000	38.0550	13.6397
2445000000.0000	38.0455	13.6552
2450000000.0000	38.0289	13.6683
2455000000.0000	38.0113	13.6933
2460000000.0000	37.9989	13.6976
2465000000.0000	37.9725	13.7245
2470000000.0000	37.9652	13.7412
2475000000.0000	37.9338	13.7285
2480000000.0000	37.9193	13.7622
2485000000.0000	37.8958	13.7651
2490000000.0000	37.8557	13.7873
2495000000.0000	37.8317	13.7990
2500000000.0000	37.8087	13.8181

■ Dielectric Parameter (2450 MHz Body)

Title ADR8995
SubTitle 2450MHz (Body)
Test Date Jun.10, 2011

Frequency	e'	e''
2400000000.0000	51.9568	13.6279
2405000000.0000	51.9639	13.6555
2410000000.0000	51.9208	13.6902
2415000000.0000	51.8751	13.6988
2420000000.0000	51.8659	13.7360
2425000000.0000	51.8215	13.7509
2430000000.0000	51.8086	13.7933
2435000000.0000	51.7820	13.8158
2440000000.0000	51.7859	13.8560
2445000000.0000	51.7161	13.8967
2450000000.0000	51.7324	13.9399
2455000000.0000	51.7122	13.9778
2460000000.0000	51.7024	13.9912
2465000000.0000	51.7094	14.0319
2470000000.0000	51.6904	14.0463
2475000000.0000	51.6744	14.0568
2480000000.0000	51.7041	14.1139
2485000000.0000	51.6650	14.0945
2490000000.0000	51.6794	14.1187
2495000000.0000	51.6488	14.1226
2500000000.0000	51.6489	14.1469