



**Spectrum Research
& Testing Lab., Inc.**
No.167, Ln. 780, Shan-Tong
Rd., Ling 8, Shan-Tong Li,
Chung-Li City, Taoyuan County
320, Taiwan (R.O.C.)

TEST REPORT

Reference No.: A12030215
Report No.: FCCA12030215
FCC ID: JY8DW06
Page: 1 of 82
Date: Apr. 24, 2012

Product Name: Travel Wi-Fi Router
Model No.: DW06
Applicant: Apotop
4F, No.119, Jiankang Road, Jhonghe Dist., New Taipei City
23858, Taiwan.
Date of Receipt: Mar. 02, 2012
Finished date of Test: Apr. 18, 2012
Applicable Standards: 47 CFR Part 15, Subpart C
ANSI C63.4: 2003

We, **Spectrum Research & Testing Laboratory Inc.**, hereby certify that one sample of the above was tested in our laboratory with positive results according to the above-mentioned standards. The records in the report are an accurate account of the results. Details of the results are given in the subsequent pages of this report.

Tested By :

Jeff Lo

(Jeff Lo)

Date:

04.24.2012

Approved By :

JH
(Johnson Ho, Director)

Date:

4/24/2012

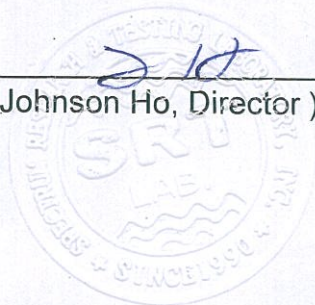



Table of Contents

1.	DOCUMENT POLICY AND TEST STATEMENT	4
1.1	DOCUMENT POLICY	4
1.2	TEST STATEMENT	4
1.3	EUT MODIFICATION.....	4
2.	DESCRIPTION OF EUT AND TEST MODE	5
2.1	GENERAL DESCRIPTION OF EUT	5
2.2	DESCRIPTION OF EUT INTERNAL DEVICE	5
2.3	DESCRIPTION OF TEST MODE.....	6
2.4	DESCRIPTION OF SUPPORT UNIT.....	7
2.5	EUT OPERATING CONDITION.....	8
3.	DESCRIPTION OF APPLIED STANDARDS.....	8
3.1	SUMMARY OF TEST RESULTS.....	9
4.	TECHNICAL CHARACTERISTICS TEST.....	10
4.1	CONDUCTED EMISSION TEST	10
4.1.1	LIMIT	10
4.1.2	TEST EQUIPMENT	10
4.1.3	TEST SETUP.....	11
4.1.4	TEST PROCEDURE.....	11
4.1.5	TEST RESULT.....	12
4.2	RADIATED EMISSION TEST	21
4.2.1	LIMIT	21
4.2.2	TEST EQUIPMENT	22
4.2.3	TEST SET-UP.....	23
4.2.4	TEST PROCEDURE.....	25
4.2.5	TEST RESULT.....	26
4.3	BANDWIDTH TEST	44
4.3.1	LIMIT	44
4.3.2	TEST EQUIPMENT	44
4.3.3	TEST SET-UP.....	44
4.3.4	TEST PROCEDURE.....	44
4.3.5	EUT OPERATING CONDITION.....	44
4.3.6	TEST RESULT.....	45



TEST REPORT

4.4	PEAK POWER TEST	51
4.4.1	LIMIT	51
4.4.2	TEST EQUIPMENT	51
4.4.3	TEST SET-UP.....	51
4.4.4	TEST PROCEDURE.....	51
4.4.5	EUT OPERATING CONDITION.....	51
4.4.6	TEST RESULT.....	52
4.5	BAND EDGE TEST	58
4.5.1	LIMIT	58
4.5.2	TEST EQUIPMENT	59
4.5.3	TEST SET-UP.....	60
4.5.4	TEST PROCEDURE.....	61
4.5.5	EUT OPERATING CONDITION.....	61
4.5.6	TEST RESULT.....	62
4.6	POWER DENSITY TEST	71
4.6.1	LIMIT	71
4.6.2	TEST EQUIPMENT	71
4.6.3	TEST SET-UP.....	71
4.6.4	TEST PROCEDURE.....	71
4.6.5	EUT OPERATING CONDITION.....	71
4.6.6	TEST RESULT.....	72
5	ANTENNA APPLICATION.....	78
5.1	ANTENNA REQUIREMENT	78
5.2	RESULT.....	78
6.	PHOTOS OF TESTING	79
7.	TERMS OF ABBREVIATION	82



1. DOCUMENT POLICY AND TEST STATEMENT

1.1 DOCUMENT POLICY

- The report shall not be reproduced except in full, without the written approval of SRT Lab, Inc.

1.2 TEST STATEMENT

- The test results in the report apply only to the unit tested by SRT Lab.
- There was no deviation from the requirements of test standards during the test.

DC power source from external power adapter which has Input: AC 120 V, 60Hz ,
Output: DC 5.1V , 0.45A

1.3 EUT MODIFICATION

- No modification in SRT Lab.



2. DESCRIPTION OF EUT AND TEST MODE

2.1 GENERAL DESCRIPTION OF EUT

PRODUCT	Travel Wi-Fi Router
MODEL NO.	DW06
POWER SUPPLY	DC power source from external USB power adapter which has Input: AC 120V ,60Hz , Output: DC 5.1 V , 0.45 A
CABLE	N/A
FREQUENCY BAND	2400 MHz ~ 2483.5 MHz
CARRIER FREQUENCY	2412 MHz ~ 2462 MHz
NUMBER OF CHANNEL	11 (802.11b,g), 7 (802.11n)
CHANNEL SPACING	5 MHz
RATED RF OUTPUT POWER	2.4GHz -11b:15.46 dBm (0.0352 W) -11g:15.20 dBm (0.0331 W) -11n:16.23 dBm (0.0420 W)
MODULATION TYPE	IEEE802.11b DSSS(BPSK/QPSK/CCK) IEEE802.11g OFDM(BPSK/16QAM/64QAM) IEEE802.11n SISO-OFDM(BPSK/16QAM/64QAM)
MODE OF OPERATION	Half duplex
BIT RATE OF TRANSMISSION	11b: 1, 2, 5.5, 11Mbps; 11g: 6, 9, 12, 18, 24, 36, 48, 54Mbps 11n: MCS0~MCS7 (Max. 150Mbps)
ANTENNA TYPE	PIFA
ANTENNA GAIN	-3.22 dBi
CHANNEL BANDWIDTH	20 MHz(802.11b,g) 40MHz(802.11n)

NOTE :

1. For more detailed information, please refer to the EUT's specification or user's manual provided by manufacturer.

2.2 DESCRIPTION OF EUT INTERNAL DEVICE

DEVICE	BRAND / MAKER	MODEL #	FCC ID / DOC	REMARK



2.3 DESCRIPTION OF TEST MODE

11(7) channels are provided by EUT of wireless. The 3 channels of lower, medium and higher were chosen for test.

There are test modes for each test configuration as below:

Mode	Modulation Type	Bandwidth	Channel	Frequency (MHz)
1	IEEE 802.11b (11Mbps)	20MHz	CH01	2412
2			CH07	2442
3			CH11	2462
4	IEEE 802.11g (54Mbps)	20MHz	CH01	2412
5			CH07	2442
6			CH11	2462
7	IEEE 802.11n (MCS7, 150Mbps)	40MHz	CH05	2422
8			CH08	2437
9			CH11	2452

NOTE :

1. Below 1 GHz, the channel 1, 7 and 11 were pre-tested in chamber and chosen the worst case for conducted and radiated emission test.
2. Above 1 GHz, the channel 1, 7 and 11 were tested individually.



2.4 DESCRIPTION OF SUPPORT UNIT

The EUT was configured by the requirement of ANSI C63.4:2003. All interface ports were connected to the appropriate support units via specific cables. The support units and cables are listed below.

NO	DEVICE	BRAND	MODEL #	FCC ID/DOC	CABLE
1	Keyboard	MircoSoft	Wired keyboard600	DoC	1.5m unshielded data cable.
2	Mouse	Logitech	M-UV83	DoC	1.5m unshielded data cable.
3	CRT Monitor	SAMSUNG	PG17IS	DoC	1.8m unshielded power cord 1.5m shielded data cable. With one core.
4	Printer	HP	3550	DoC	1.5m unshielded power cord 1.5m shielded data cable.
5	Notebook	ASUS	F81SE	DoC	1.5m AC power cord 1.2m DC shielded power cable.
6	USB Adapter	Foxlink	A1357	N/A	Input: 100~240V, 50/60Hz, 0.45A Output: 5.1V, 2.1A
7	iPod	Apple	A1320	DoC	1.0m shielded data cable.
8	Extension power cord	PowerSync	PTR-863-01	N/A	1.8m shielded power cable

NOTE : For the actual test configuration, please refer to the photos of testing.



2.5 EUT OPERATING CONDITION

1. Setup the EUT and all peripheral devices .
2. Turn on the power of all equipment and EUT.
3. We will use the following programs under Windows XP system to test EUT.
 - 3.1 "EMI Test" program.

PC sent "H" pattern signal and detect following peripherals directly or via EUT:

- Color Monitor
- Keyboard
- Mouse
- Printer
- HDD

- 3.2 "Ping IP", program.

Use the ping command to link LAN port and local simulation PC through Ethernet hub.

3. DESCRIPTION OF APPLIED STANDARDS

The EUT is a kind of wireless product. According to the specifications provided by the applicant, it must comply with the requirements of the following standards:

47 CFR Part 15, Subpart C
ANSI C63.4: 2003

All tests have been performed and recorded as the above standards.



3.1 SUMMARY OF TEST RESULTS

The EUT has been tested according to the following specifications:

STANDARD SECTION	TEST TYPE AND LIMIT	RESULTS
15.203	Antenna requirement Limit : max. 6dBi	PASS
15.207	AC Power Conducted Emission	PASS
15.247(a)(2)	Spectrum Bandwidth of a Direct Sequence Spread Spectrum System Limit : min. 500kHz	PASS
15.247(b)	Maximum Peak Conducted Output Power Limit: max. 30dBm	PASS
15.247(d)	Transmitter Radiated Emissions Limit: Table 15.209	PASS
15.247(e)	Power Spectral Density Limit: max. 8dBm	PASS
15.247(d)	Band Edge Measurement Limit: 20dB less than the peak value of fundamental frequency	PASS



4. TECHNICAL CHARACTERISTICS TEST

4.1 CONDUCTED EMISSION TEST

4.1.1 LIMIT

Frequency (MHz)	Class A (dB μ V)		Class B (dB μ V)	
	Quasi-peak	Average	Quasi-peak	Average
0.15 - 0.5	79	66	66 - 56	56 - 46
0.50 - 5.0	73	60	56	46
5.0 - 30.0	73	60	60	50

NOTE :

1. The lower limit shall apply at the transition frequencies.
2. The limit decreases in line with the logarithm of the frequency in the range of 0.15 to 0.50 MHz.

4.1.2 TEST EQUIPMENT

The following test equipment was used for the test:

EQUIPMENT/ FACILITIES	SPECIFICATIONS	MANUFACTURER	MODEL#/ SERIAL#	DUE DATE OF CAL. & CAL. CENTER
EMI TEST RECEIVER	9kHz TO 2.75 GHz	ROHDE & SCHWARZ	ESCS30 / 100376	Dec 2012 ETC
LISN	50 μ H, 50 ohm	FCC	FCC-LISN-50-25-2 / 01017	Jun 2012 ETC
LISN	50 μ H, 50 ohm	SOLAR	9252-50-R24-BNC / 951315	Nov 2012 ETC
50 OHM TERMINATOR	50 ohm	HP	11593A / #1	Dec 2012 ETC
COAXIAL CABLE	5M	TIMES	LMR-400 / #5M(L3TCAB003)	May 2012 ETC
Filter	2 LINE, 30A	FIL.COIL	FC-943 / 771	NCR
GROUND PLANE	2M (H) x 3M (W)	SRT	N/A	NCR
GROUND PLANE	2.5M (H) x 3M (W)	SRT	N/A	NCR

NOTE: The calibration interval of the above test equipment is one year and the calibrations are traceable to NML/ROC and NIST/USA.



4.1.3 TEST SETUP

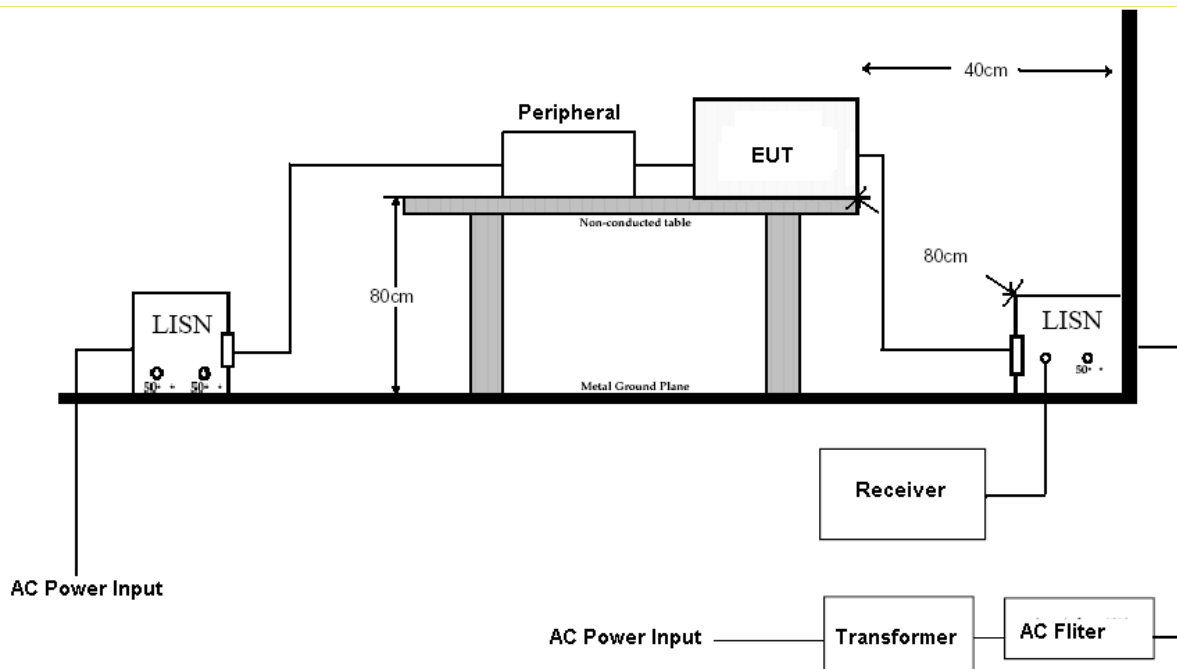

NOTE :

1. The EUT was put on a wooden table with 0.8m heights above ground plane, and 0.4m away from reference ground plane (> 2mx2m).
2. For the actual test configuration, please refer to the photos of testing.

4.1.4 TEST PROCEDURE

The EUT was tested according to the requirement of ANSI C63.4:2003 and CISPR22:2003. The frequency spectrum from 0.15 MHz to 30 MHz was investigated. The LISN used was 50 ohm/50 μ H as specified. All readings were quasi-peak and average values with 10 kHz resolution bandwidth of the test receiver. The EUT system was operated in all typical methods by users. Both lines of the power mains of EUT were measured and the cables connected to EUT and support units were moved to find the maximum emission levels for each frequency. First, find the margin or higher points at least 6 points by software, then use manual to find the maximum data. The procedure is referred on the test procedure of SRT LAB.



4.1.5 TEST RESULT

Temperature:	<u>24 °C</u>	Humidity:	<u>54 %RH</u>
Frequency Range:	<u>0.15 – 30 MHz</u>	Tested Mode:	<u>11B_CH1</u>
Receiver Detector:	<u>Q.P. and AV.</u>	Modulation Type:	<u>QPSK</u>
Tested By:	<u>Jeff Lo</u>	Tested Channel:	<u>2412 MHz</u>
		Tested Date:	<u>Mar. 30, 2012</u>

Power Line Measured : Line

Freq. (MHz)	Correct. Factor (dB)	Reading Value (dB μ V)		Emission Level (dB μ V)		Limit (dB μ V)		Margin (dB)	
		Q.P.	AV.	Q.P.	AV.	Q.P.	AV.	Q.P.	AV.
0.150	0.13	46.60	33.36	46.73	33.49	66.00	56.00	-19.27	-22.51
0.153	0.13	47.36	31.24	47.49	31.37	65.91	55.91	-18.42	-24.54
0.620	-0.04	31.77	31.77	31.73	31.73	56.00	46.00	-24.27	-14.27
14.216	0.23	31.30	26.77	31.53	27.00	60.00	50.00	-28.47	-23.00
14.703	0.24	31.62	27.12	31.86	27.36	60.00	50.00	-28.14	-22.64
23.128	0.41	39.59	37.25	40.00	37.66	60.00	50.00	-20.00	-12.34

Power Line Measured : Neutral

Freq. (MHz)	Correct. Factor (dB)	Reading Value (dB μ V)		Emission Level (dB μ V)		Limit (dB μ V)		Margin (dB)	
		Q.P.	AV.	Q.P.	AV.	Q.P.	AV.	Q.P.	AV.
0.150	0.51	46.72	33.81	47.23	34.32	66.00	56.00	-18.77	-21.68
0.153	0.51	47.50	34.62	48.01	35.13	65.91	55.91	-17.90	-20.78
0.624	0.39	38.15	32.34	38.54	32.73	56.00	46.00	-17.46	-13.27
1.636	0.37	38.90	37.41	39.27	37.78	56.00	46.00	-16.73	-8.22
3.269	0.38	35.54	33.90	35.92	34.28	56.00	46.00	-20.08	-11.72
20.258	0.76	47.78	44.26	48.54	45.02	60.00	50.00	-11.46	-4.98

NOTE :

1. Measurement uncertainty is ± 3.61 dB
2. Emission level = Reading value + Correction factor
3. Correction Factor = Cable loss + Insertion loss of LISN
4. Margin value = Emission level - Limit
5. The emission of other frequencies was very low against the limit.
6. "-": The Quasi-peak reading value also meets average limit and measurement with the average detector is unnecessary.



TEST REPORT

Temperature:	24 °C	Humidity:	54 %RH
Frequency Range:	0.15 – 30 MHz	Tested Mode:	11B_CH7
Receiver Detector:	Q.P. and AV.	Modulation Type:	QPSK
Tested By:	Jeff Lo	Tested Channel:	2442 MHz
		Tested Date:	Mar. 30, 2012

Power Line Measured : Line

Freq. (MHz)	Correct. Factor (dB)	Reading Value (dB μ V)		Emission Level (dB μ V)		Limit (dB μ V)		Margin (dB)	
		Q.P.	AV.	Q.P.	AV.	Q.P.	AV.	Q.P.	AV.
0.150	0.13	45.00	32.81	45.13	32.94	66.00	56.00	-20.87	-23.06
0.153	0.13	45.68	33.52	45.81	33.65	65.91	55.91	-20.10	-22.26
0.630	-0.04	32.53	26.36	32.49	26.32	56.00	46.00	-23.51	-19.68
11.892	0.18	30.83	26.98	31.01	27.16	60.00	50.00	-28.99	-22.84
12.744	0.20	29.96	25.89	30.16	26.09	60.00	50.00	-29.84	-23.91
23.128	0.41	39.27	37.05	39.68	37.46	60.00	50.00	-20.32	-12.54

Power Line Measured : Neutral

Freq. (MHz)	Correct. Factor (dB)	Reading Value (dB μ V)		Emission Level (dB μ V)		Limit (dB μ V)		Margin (dB)	
		Q.P.	AV.	Q.P.	AV.	Q.P.	AV.	Q.P.	AV.
0.150	0.51	45.66	33.58	46.17	34.09	66.00	56.00	-19.83	-21.91
0.153	0.51	46.52	34.28	47.03	34.79	65.91	55.91	-18.88	-21.12
1.636	0.37	38.82	37.38	39.19	37.75	56.00	46.00	-16.81	-8.25
3.269	0.38	34.60	32.58	34.98	32.96	56.00	46.00	-21.02	-13.04
12.196	0.55	37.21	33.88	37.76	34.43	60.00	50.00	-22.24	-15.57
20.258	0.76	47.76	44.47	48.52	45.23	60.00	50.00	-11.48	-4.77

NOTE :

1. Measurement uncertainty is ± 3.61 dB
2. Emission level = Reading value + Correction factor
3. Correction Factor = Cable loss + Insertion loss of LISN
4. Margin value = Emission level - Limit
5. The emission of other frequencies was very low against the limit.
6. "-": The Quasi-peak reading value also meets average limit and measurement with the average detector is unnecessary.



TEST REPORT

Temperature:	24 °C	Humidity:	54 %RH
Frequency Range:	0.15 – 30 MHz	Tested Mode:	11B_CH11
Receiver Detector:	Q.P. and AV.	Modulation Type:	QPSK
Tested By:	Jeff Lo	Tested Channel:	2472 MHz
		Tested Date:	Mar. 30, 2012

Power Line Measured : Line

Freq. (MHz)	Correct. Factor (dB)	Reading Value (dB μ V)		Emission Level (dB μ V)		Limit (dB μ V)		Margin (dB)	
		Q.P.	AV.	Q.P.	AV.	Q.P.	AV.	Q.P.	AV.
0.150	0.13	44.20	32.56	44.33	32.69	66.00	56.00	-21.67	-23.31
0.153	0.13	44.74	33.14	44.87	33.27	65.91	55.91	-21.04	-22.64
0.630	-0.04	32.67	26.50	32.63	26.46	56.00	46.00	-23.37	-19.54
11.953	0.18	29.65	26.07	29.83	26.25	60.00	50.00	-30.17	-23.75
12.135	0.19	29.50	25.72	29.69	25.91	60.00	50.00	-30.31	-24.09
23.128	0.41	38.89	37.00	39.30	37.41	60.00	50.00	-20.70	-12.59

Power Line Measured : Neutral

Freq. (MHz)	Correct. Factor (dB)	Reading Value (dB μ V)		Emission Level (dB μ V)		Limit (dB μ V)		Margin (dB)	
		Q.P.	AV.	Q.P.	AV.	Q.P.	AV.	Q.P.	AV.
0.150	0.51	45.00	33.20	45.51	33.71	66.00	56.00	-20.49	-22.29
0.153	0.51	45.56	33.76	46.07	34.27	65.91	55.91	-19.84	-21.64
0.634	0.39	38.51	33.15	38.90	33.54	56.00	46.00	-17.10	-12.46
1.636	0.37	38.70	37.19	39.07	37.56	56.00	46.00	-16.93	-8.44
14.703	0.62	37.82	34.60	38.44	35.22	60.00	50.00	-21.56	-14.78
20.320	0.76	45.78	43.01	46.54	43.77	60.00	50.00	-13.46	-6.23

NOTE :

1. Measurement uncertainty is ± 3.61 dB
2. Emission level = Reading value + Correction factor
3. Correction Factor = Cable loss + Insertion loss of LISN
4. Margin value = Emission level - Limit
5. The emission of other frequencies was very low against the limit.
6. "-": The Quasi-peak reading value also meets average limit and measurement with the average detector is unnecessary.



TEST REPORT

Temperature:	24 °C	Humidity:	54 %RH
Frequency Range:	0.15 – 30 MHz	Tested Mode:	11G_CH1
Receiver Detector:	Q.P. and AV.	Modulation Type:	OFDM
Tested By:	Jeff Lo	Tested Channel:	2412 MHZ
		Tested Date:	Mar. 30, 2012

Power Line Measured : Line

Freq. (MHz)	Correct. Factor (dB)	Reading Value (dB μ V)		Emission Level (dB μ V)		Limit (dB μ V)		Margin (dB)	
		Q.P.	AV.	Q.P.	AV.	Q.P.	AV.	Q.P.	AV.
0.150	0.13	44.74	33.40	44.87	33.53	66.00	56.00	-21.13	-22.47
0.153	0.13	45.20	33.91	45.33	34.04	65.91	55.91	-20.58	-21.87
0.630	-0.04	33.37	26.87	33.33	26.83	56.00	46.00	-22.67	-19.17
14.216	0.23	30.84	26.64	31.07	26.87	60.00	50.00	-28.93	-23.13
14.744	0.24	30.44	24.32	30.68	24.56	60.00	50.00	-29.32	-25.44
23.128	0.41	40.35	38.26	40.76	38.67	60.00	50.00	-19.24	-11.33

Power Line Measured : Neutral

Freq. (MHz)	Correct. Factor (dB)	Reading Value (dB μ V)		Emission Level (dB μ V)		Limit (dB μ V)		Margin (dB)	
		Q.P.	AV.	Q.P.	AV.	Q.P.	AV.	Q.P.	AV.
0.150	0.51	45.54	34.14	46.05	34.65	66.00	56.00	-19.95	-21.35
0.153	0.51	46.02	34.55	46.53	35.06	65.91	55.91	-19.38	-20.85
0.615	0.39	38.21	31.96	38.60	32.35	56.00	46.00	-17.40	-13.65
1.636	0.37	37.82	36.46	38.19	36.83	56.00	46.00	-17.81	-9.17
1.645	0.37	34.66	17.82	35.03	18.19	56.00	46.00	-20.97	-27.81
20.258	0.76	48.24	44.72	49.00	45.48	60.00	50.00	-11.00	-4.52

NOTE :

1. Measurement uncertainty is ± 3.61 dB
2. Emission level = Reading value + Correction factor
3. Correction Factor = Cable loss + Insertion loss of LISN
4. Margin value = Emission level - Limit
5. The emission of other frequencies was very low against the limit.
6. "-": The Quasi-peak reading value also meets average limit and measurement with the average detector is unnecessary.



TEST REPORT

Temperature:	24 °C	Humidity:	54 %RH
Frequency Range:	0.15 – 30 MHz	Tested Mode:	11G_CH7
Receiver Detector:	Q.P. and AV.	Modulation Type:	OFDM
Tested By:	Jeff Lo	Tested Channel:	2442 MHZ
		Tested Date:	Mar. 30, 2012

Power Line Measured : Line

Freq. (MHz)	Correct. Factor (dB)	Reading Value (dB μ V)		Emission Level (dB μ V)		Limit (dB μ V)		Margin (dB)	
		Q.P.	AV.	Q.P.	AV.	Q.P.	AV.	Q.P.	AV.
0.153	0.13	44.94	33.67	45.07	33.80	65.91	55.91	-20.84	-22.11
0.498	-0.04	31.73	25.20	31.69	25.16	56.06	46.06	-24.37	-20.90
0.615	-0.04	37.51	31.56	37.47	31.52	56.00	46.00	-18.53	-14.48
1.636	-0.02	38.52	36.99	38.50	36.97	56.00	46.00	-17.50	-9.03
14.734	0.24	38.12	35.59	38.36	35.83	60.00	50.00	-21.64	-14.17
18.239	0.31	42.88	40.24	43.19	40.55	60.00	50.00	-16.81	-9.45

Power Line Measured : Neutral

Freq. (MHz)	Correct. Factor (dB)	Reading Value (dB μ V)		Emission Level (dB μ V)		Limit (dB μ V)		Margin (dB)	
		Q.P.	AV.	Q.P.	AV.	Q.P.	AV.	Q.P.	AV.
0.150	0.51	43.10	32.39	43.61	32.90	66.00	56.00	-22.39	-23.10
0.153	0.51	43.56	32.81	44.07	33.32	65.91	55.91	-21.84	-22.59
0.620	0.39	32.05	25.65	32.44	26.04	56.00	46.00	-23.56	-19.96
1.200	0.37	22.17	13.80	22.54	14.17	56.00	46.00	-33.46	-31.83
14.277	0.61	30.14	26.03	30.75	26.64	60.00	50.00	-29.25	-23.36
16.230	0.66	36.71	34.21	37.37	34.87	60.00	50.00	-22.63	-15.13

NOTE :

1. Measurement uncertainty is ± 3.61 dB
2. Emission level = Reading value + Correction factor
3. Correction Factor = Cable loss + Insertion loss of LISN
4. Margin value = Emission level - Limit
5. The emission of other frequencies was very low against the limit.
6. "-": The Quasi-peak reading value also meets average limit and measurement with the average detector is unnecessary.



**Spectrum Research
& Testing Lab., Inc.**
No.167,Ln. 780, Shan-Tong
Rd.,Ling 8, Shan-Tong Li,
Chung-Li City, Taoyuan County
320, Taiwan (R.O.C.)

TEST REPORT

Reference No.: A12030215
Report No.: FCCA12030215
FCC ID: JY8DW06
Page: 17 of 82
Date: Apr. 24, 2012

Temperature:	24 °C	Humidity:	54 %RH
Frequency Range:	0.15 – 30 MHz	Tested Mode:	11G_CH11
Receiver Detector:	Q.P. and AV.	Modulation Type:	OFDM
Tested By:	Jeff Lo	Tested Channel:	2472 MHZ
		Tested Date:	Mar. 30, 2012

Power Line Measured : Line

Freq. (MHz)	Correct. Factor (dB)	Reading Value (dB μ V)		Emission Level (dB μ V)		Limit (dB μ V)		Margin (dB)	
		Q.P.	AV.	Q.P.	AV.	Q.P.	AV.	Q.P.	AV.
0.150	0.13	43.06	32.39	43.19	32.52	66.00	56.00	-22.81	-23.48
0.153	0.13	43.56	32.83	43.69	32.96	65.91	55.91	-22.22	-22.95
0.639	-0.04	32.19	25.67	32.15	25.63	56.00	46.00	-23.85	-20.37
12.196	0.19	30.20	26.90	30.39	27.09	60.00	50.00	-29.61	-22.91
14.734	0.24	31.55	27.74	31.79	27.98	60.00	50.00	-28.21	-22.02
23.128	0.41	35.87	33.38	36.28	33.79	60.00	50.00	-23.72	-16.21

Power Line Measured : Neutral

Freq. (MHz)	Correct. Factor (dB)	Reading Value (dB μ V)		Emission Level (dB μ V)		Limit (dB μ V)		Margin (dB)	
		Q.P.	AV.	Q.P.	AV.	Q.P.	AV.	Q.P.	AV.
0.150	0.51	44.04	33.06	44.55	33.57	66.00	56.00	-21.45	-22.43
0.153	0.51	44.48	33.45	44.99	33.96	65.91	55.91	-20.92	-21.95
0.639	0.39	38.17	32.64	38.56	33.03	56.00	46.00	-17.44	-12.97
1.636	0.37	38.06	36.46	38.43	36.83	56.00	46.00	-17.57	-9.17
14.734	0.62	37.80	33.53	38.42	34.15	60.00	50.00	-21.58	-15.85
20.258	0.76	45.32	42.43	46.08	43.19	60.00	50.00	-13.92	-6.81

NOTE :

1. Measurement uncertainty is ± 3.61 dB
2. Emission level = Reading value + Correction factor
3. Correction Factor = Cable loss + Insertion loss of LISN
4. Margin value = Emission level - Limit
5. The emission of other frequencies was very low against the limit.
6. "-": The Quasi-peak reading value also meets average limit and measurement with the average detector is unnecessary.



TEST REPORT

Temperature:	24 °C	Humidity:	54 %RH
Frequency Range:	0.15 – 30 MHz	Tested Mode:	11N_CH5
Receiver Detector:	Q.P. and AV.	Modulation Type:	OFDM
Tested By:	Jeff Lo	Tested Channel:	2422 MHZ
		Tested Date:	Mar. 30, 2012

Power Line Measured : Line

Freq. (MHz)	Correct. Factor (dB)	Reading Value (dB μ V)		Emission Level (dB μ V)		Limit (dB μ V)		Margin (dB)	
		Q.P.	AV.	Q.P.	AV.	Q.P.	AV.	Q.P.	AV.
0.150	0.13	42.82	32.42	42.95	32.55	66.00	56.00	-23.05	-23.45
0.153	0.13	43.12	32.76	43.25	32.89	65.91	55.91	-22.66	-23.02
0.639	-0.04	32.43	25.77	32.39	25.73	56.00	46.00	-23.61	-20.27
12.135	0.19	28.69	26.38	28.88	26.57	60.00	50.00	-31.12	-23.43
14.703	0.24	30.05	26.96	30.29	27.20	60.00	50.00	-29.71	-22.80
23.128	0.41	35.95	33.15	36.36	33.56	60.00	50.00	-23.64	-16.44

Power Line Measured : Neutral

Freq. (MHz)	Correct. Factor (dB)	Reading Value (dB μ V)		Emission Level (dB μ V)		Limit (dB μ V)		Margin (dB)	
		Q.P.	AV.	Q.P.	AV.	Q.P.	AV.	Q.P.	AV.
0.150	0.51	43.88	33.01	44.39	33.52	66.00	56.00	-21.61	-22.48
0.153	0.51	44.28	33.36	44.79	33.87	65.91	55.91	-21.12	-22.04
0.630	0.39	38.63	32.94	39.02	33.33	56.00	46.00	-16.98	-12.67
1.636	0.37	38.14	36.54	38.51	36.91	56.00	46.00	-17.49	-9.09
1.645	0.37	35.14	19.21	35.51	19.58	56.00	46.00	-20.49	-26.42
20.258	0.76	44.84	42.60	45.60	43.36	60.00	50.00	-14.40	-6.64

NOTE :

1. Measurement uncertainty is ± 3.61 dB
2. Emission level = Reading value + Correction factor
3. Correction Factor = Cable loss + Insertion loss of LISN
4. Margin value = Emission level - Limit
5. The emission of other frequencies was very low against the limit.
6. "-": The Quasi-peak reading value also meets average limit and measurement with the average detector is unnecessary.



TEST REPORT

Temperature:	24 °C	Humidity:	54 %RH
Frequency Range:	0.15 – 30 MHz	Tested Mode:	11N_CH8
Receiver Detector:	Q.P. and AV.	Modulation Type:	OFDM
Tested By:	Jeff Lo	Tested Channel:	2437 MHZ
		Tested Date:	Mar. 30, 2012

Power Line Measured : Line

Freq. (MHz)	Correct. Factor (dB)	Reading Value (dB μ V)		Emission Level (dB μ V)		Limit (dB μ V)		Margin (dB)	
		Q.P.	AV.	Q.P.	AV.	Q.P.	AV.	Q.P.	AV.
0.150	0.13	42.64	32.38	42.77	32.51	66.00	56.00	-23.23	-23.49
0.153	0.13	43.02	32.74	43.15	32.87	65.91	55.91	-22.76	-23.04
0.634	-0.04	32.69	26.39	32.65	26.35	56.00	46.00	-23.35	-19.65
11.892	0.18	29.65	27.24	29.83	27.42	60.00	50.00	-30.17	-22.58
14.734	0.24	31.09	26.32	31.33	26.56	60.00	50.00	-28.67	-23.44
18.301	0.32	34.10	30.87	34.42	31.19	60.00	50.00	-25.58	-18.81

Power Line Measured : Neutral

Freq. (MHz)	Correct. Factor (dB)	Reading Value (dB μ V)		Emission Level (dB μ V)		Limit (dB μ V)		Margin (dB)	
		Q.P.	AV.	Q.P.	AV.	Q.P.	AV.	Q.P.	AV.
0.405	0.40	31.18	25.65	31.58	26.05	58.71	48.71	-27.13	-22.66
0.625	0.39	38.23	32.49	38.62	32.88	56.00	46.00	-17.38	-13.12
1.636	0.37	38.12	36.62	38.49	36.99	56.00	46.00	-17.51	-9.01
3.279	0.38	33.22	29.27	33.60	29.65	56.00	46.00	-22.40	-16.35
14.734	0.62	38.24	34.69	38.86	35.31	60.00	50.00	-21.14	-14.69
18.239	0.71	43.50	40.83	44.21	41.54	60.00	50.00	-15.79	-8.46

NOTE :

1. Measurement uncertainty is ± 3.61 dB
2. Emission level = Reading value + Correction factor
3. Correction Factor = Cable loss + Insertion loss of LISN
4. Margin value = Emission level - Limit
5. The emission of other frequencies was very low against the limit.
6. "-": The Quasi-peak reading value also meets average limit and measurement with the average detector is unnecessary.



TEST REPORT

Temperature:	<u>24 °C</u>	Humidity:	<u>54 %RH</u>
Frequency Range:	<u>0.15 – 30 MHz</u>	Tested Mode:	<u>11N_CH11</u>
Receiver Detector:	<u>Q.P. and AV.</u>	Modulation Type:	<u>OFDM</u>
Tested By:	<u>Jeff Lo</u>	Tested Channel:	<u>2462 MHZ</u>
		Tested Date:	<u>Mar. 30, 2012</u>

Power Line Measured : Line

Freq. (MHz)	Correct. Factor (dB)	Reading Value (dB μ V)		Emission Level (dB μ V)		Limit (dB μ V)		Margin (dB)	
		Q.P.	AV.	Q.P.	AV.	Q.P.	AV.	Q.P.	AV.
0.150	0.13	42.76	32.44	42.89	32.57	66.00	56.00	-23.11	-23.43
0.153	0.13	42.96	32.72	43.09	32.85	65.91	55.91	-22.82	-23.06
0.639	-0.04	32.25	25.74	32.21	25.70	56.00	46.00	-23.79	-20.30
12.196	0.19	29.58	27.06	29.77	27.25	60.00	50.00	-30.23	-22.75
14.734	0.24	31.11	26.55	31.35	26.79	60.00	50.00	-28.65	-23.21
17.696	0.30	32.53	32.53	32.83	32.83	60.00	50.00	-27.17	-17.17

Power Line Measured : Neutral

Freq. (MHz)	Correct. Factor (dB)	Reading Value (dB μ V)		Emission Level (dB μ V)		Limit (dB μ V)		Margin (dB)	
		Q.P.	AV.	Q.P.	AV.	Q.P.	AV.	Q.P.	AV.
0.153	0.51	44.02	33.33	44.53	33.84	65.91	55.91	-21.38	-22.07
0.644	0.39	37.73	31.79	38.12	32.18	56.00	46.00	-17.88	-13.82
1.636	0.37	38.00	36.42	38.37	36.79	56.00	46.00	-17.63	-9.21
1.645	0.37	35.10	19.57	35.47	19.94	56.00	46.00	-20.53	-26.06
14.734	0.62	37.22	31.30	37.84	31.92	60.00	50.00	-22.16	-18.08
16.230	0.66	43.56	41.61	44.22	42.27	60.00	50.00	-15.78	-7.73

NOTE :

1. Measurement uncertainty is ± 3.61 dB
2. Emission level = Reading value + Correction factor
3. Correction Factor = Cable loss + Insertion loss of LISN
4. Margin value = Emission level - Limit
5. The emission of other frequencies was very low against the limit.
6. "-": The Quasi-peak reading value also meets average limit and measurement with the average detector is unnecessary.



4.2 RADIATED EMISSION TEST

4.2.1 LIMIT

FCC Part15, Subpart C Section 15.209 limit of radiated emission for frequency below1000MHz. The emissions from an intentional radiator shall not exceed the field strength levels specified in the following table:

FREQUENCY (MHz)	DISTANCE (m)	FIELD STRENGTH (dB μ V/m)
0.009 - 0.490	300	2400/F(KHz)
0.490 - 1.705	30	24000/F(KHz)
1.705 - 30	30	30
30 - 88	3	40.0
88 - 216	3	43.5
216 - 960	3	46.0
Above 960	3	54.0

NOTE :

1. In the emission tables above , the tighter limit applies at the band edges.
2. Distance refers to the distance between measuring instrument, antenna, and the closest point of any part of the device or system.
- 3.

FCC Part 15, Section15.35(b) limit of radiated emission for frequency above 1000 MHz

FREQUENCY (MHz)	Class A (dBuV/m) (at 3m)		Class B (dBuV/m) (at 3m)	
	PEAK	AVERAGE	PEAK	AVERAGE
Above 1000	80.0	60.0	74.0	54.0

FCC Part 15, Section15.249 limit of radiated emission:

FREQUENCY (MHz)	Fundamental		Harmonics	
	PEAK	AVERAGE	PEAK	AVERAGE
2400 – 2483.5	114dBuV/m (NOTE 2)	50mV/m (94dBuV/m)	74dBuV/m (NOTE 2)	500uV/m (54dBuV/m)

NOTE :

1. Field strength limits are specified at a distance of 3 meters.
2. the peak field strength of any emission shall not exceed the maximum permitted average limits specified above by more than 20 dB under any condition of modulation.



TEST REPORT

4.2.2 TEST EQUIPMENT

The following test equipment was used during the radiated emission test:

EQUIPMENT/ FACILITIES	SPECIFICATIONS	MANUFACTURER	MODEL#/ SERIAL#	DUE DATE OF CAL. & CAL. CENTER
EMI TEST RECEIVER	20 MHz TO 1000 MHz	ROHDE & SCHWARZ	ESVS30 / 841977/003	Dec. 2012 ETC
BI-LOG ANTENNA	30MHz to 2GHz	SCHFFNER	CBL6141A / 4128	May. 2012 ETC
COAXIAL CABLE	30M	TIMES	LMR-400 / #30M	Nov. 2012 SRT
FILTER	2 LINE, 30A	FIL.COIL	FC-943 / 869	May. 2012 ETC
OATS	3 – 10 M MEASUREMENT	SRT	SRT-1	Jun. 2012 SRT
SPECTRUM ANALYZER	9K-40GHz	ROHDE & SCHWARZ	FSP40 / 100093	Dec. 2012 ETC
PRE-AMPLIFIER	1 GHz TO 26.5 GHz	AGILENT	8449B/ 3008A01019	Jan. 2013 ETC
HORN ANTENNA	1 GHz TO 18 GHz	EMCO	3115/ 9602-4681	Nov. 2012 ETC
K-TYPE CABLE	15M	HUBER SUHNER	SF102-40/2*11 / 23932/2	Feb. 2013 ETC
K-TYPE CABLE	1M	HUBER SUHNER	SF102-40/2*11 / 28934/2	May. 2012 ETC

NOTE:

1. The calibration interval of the above test equipment is one year and the calibrations are traceable to NML/ROC and NIST/USA.



4.2.3 TEST SET-UP (30MHz~1000MHz)

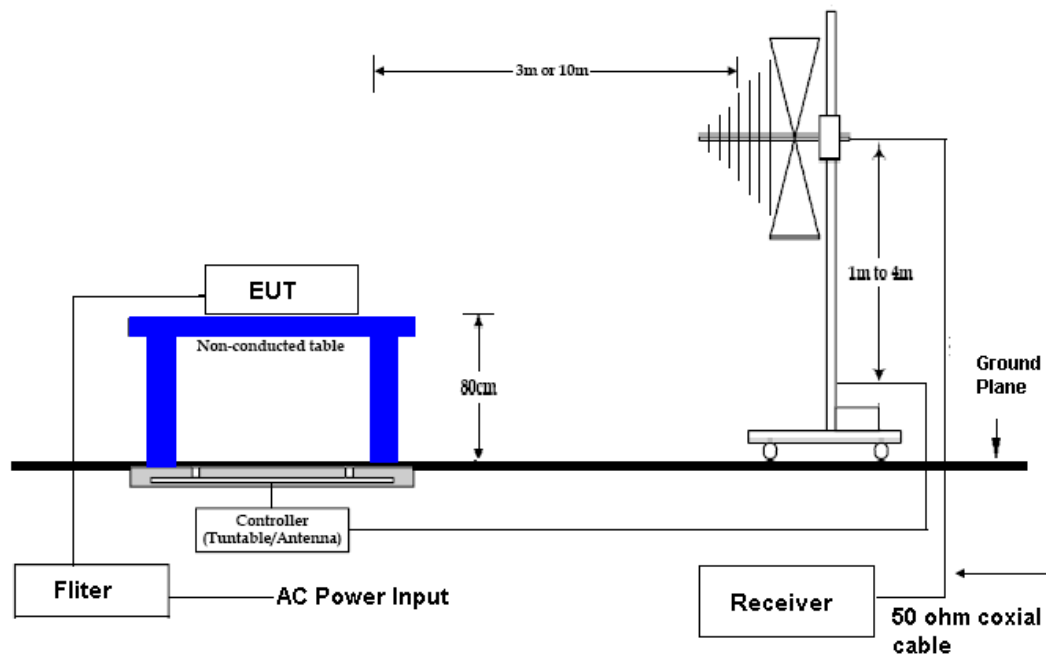

NOTE :

1. The EUT system was put on a wooden table with 0.8m heights above a ground plane.
2. For the actual test configuration, please refer to the photos of testing.



TEST SET- UP (1GHz - 25GHz)

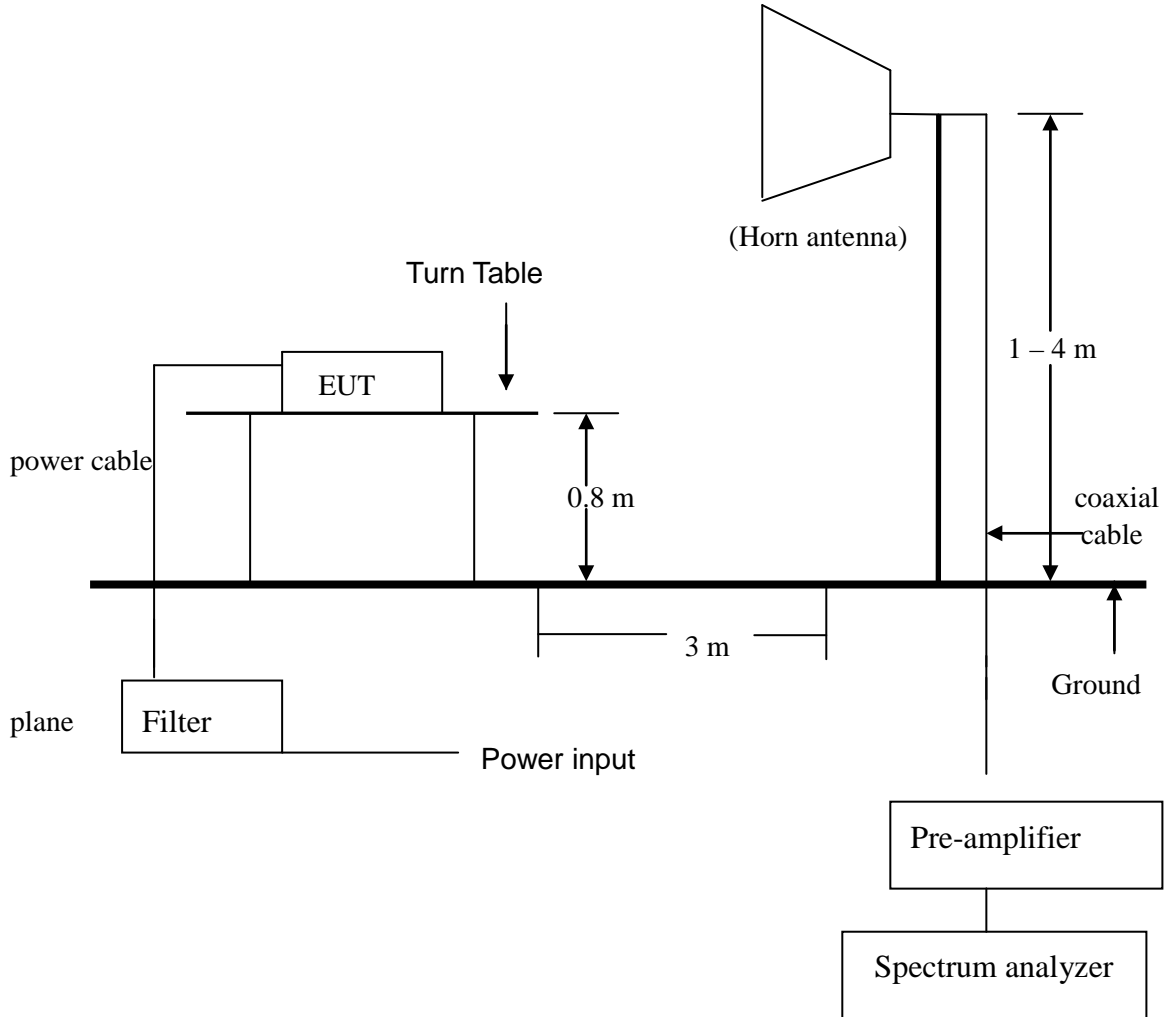

NOTE :

1. The EUT system was put on a wooden table with 0.8m heights above a ground plane. For the actual test configuration, please refer to the photos of testing.



**Spectrum Research
& Testing Lab., Inc.**
No.167,Ln. 780, Shan-Tong
Rd.,Ling 8, Shan-Tong Li,
Chung-Li City, Taoyuan County
320, Taiwan (R.O.C.)

TEST REPORT

Reference No.: A12030215
Report No.:FCCA12030215
FCC ID: JY8DW06
Page:25 of 82
Date: Apr. 24, 2012

4.2.4 TEST PROCEDURE

The EUT was tested according to the requirement of ANSI C63.4:2003 and CISPR 22:2008. The measurements were made at an open area test site with 3 meter measurement distance under 1 GHz and with 3m distance above 1GHz. The frequency spectrum measured started from 30 MHz. Under 1 GHz, all readings were quasi-peak values with 120 kHz resolution bandwidth of the test receiver. Above 1 GHz, the measurements were made at an open area test site with 3 meter measurement distance and all readings were peak or average values with 1 MHz resolution bandwidth of the test receiver. The EUT system was operated in all typical methods by users. The cables connected to EUT and support units were moved to find the maximum emission levels for each frequency.

First, find the margin or higher points at least 6 points by software, then use manual to find the maximum data. The procedure is referred on the test procedure of SRT LAB.



TEST REPORT

4.2.5 TEST RESULT

Temperature:	23 °C	Humidity:	57 %RH
Frequency Range:	30 – 1000 MHz	Measured Distance:	3m
Receiver Detector:	Q.P.	Tested Mode:	11B_CH1
Tested By:	Jeff Lo	Tested Date:	Apr. 12, 2012

Antenna Polarization : Horizontal

Frequency (MHz)	Cable Loss (dB)	Antenna Factor (dB/m)	Reading Data (dBμV)	Emission Level (dBμV/m)	Limit (dBμV/m)	Margin (dB)	AZ(°)	EL(m)
68.1700	1.20	8.30	20.1	29.6	40.0	-10.4	124	3.88
154.3800	1.74	12.36	16.3	30.4	43.5	-13.1	338	3.62
281.4400	2.31	13.21	14.3	29.8	46.0	-16.2	159	3.22
313.5100	2.45	14.21	16.2	32.9	46.0	-13.1	269	3.12
457.8600	3.03	17.40	8.9	29.3	46.0	-16.7	271	2.68
473.1200	3.09	17.62	9.6	30.3	46.0	-15.7	273	2.63

Antenna Polarization : Vertical

Frequency (MHz)	Cable Loss (dB)	Antenna Factor (dB/m)	Reading Data (dBμV)	Emission Level (dBμV/m)	Limit (dBμV/m)	Margin (dB)	AZ(°)	EL(m)
68.1500	1.20	8.30	14.6	24.1	40.0	-15.9	51	1.12
275.2300	2.30	13.25	12.6	28.2	46.0	-17.9	72	1.76
290.4800	2.40	13.30	12.9	28.6	46.0	-17.4	164	1.81
297.3600	2.40	13.72	13.8	29.9	46.0	-16.1	165	1.83
351.5900	2.60	15.12	12.0	29.7	46.0	-16.3	167	1.99
457.8300	3.03	17.40	9.2	29.6	46.0	-16.4	171	2.32

NOTE :

1. Measurement uncertainty is ±4.73dB.
2. "*": Measurement does not apply for this frequency.
3. Emission Level = Reading Value + Ant. Factor + Cable Loss.
4. The field strength of other emission frequencies were very low against the limit.



TEST REPORT

Temperature:	23°C	Humidity:	57 %RH
Frequency Range:	30 – 1000 MHz	Measured Distance:	3m
Receiver Detector:	Q.P.	Tested Mode:	11B_CH7
Tested By:	Jeff Lo	Tested Date:	Apr. 12, 2012

Antenna Polarization : Horizontal

Frequency (MHz)	Cable Loss (dB)	Antenna Factor (dB/m)	Reading Data (dBμV)	Emission Level (dBμV/m)	Limit (dBμV/m)	Margin (dB)	AZ(°)	EL(m)
68.1900	1.20	8.30	19.6	29.1	40.0	-10.9	211	3.88
114.3300	1.50	11.36	14.0	26.9	43.5	-16.6	304	3.74
204.1500	1.94	11.96	14.9	28.8	43.5	-14.7	15	3.46
269.5500	2.29	13.31	13.1	28.7	46.0	-17.3	333	3.26
317.0170	2.47	14.31	15.3	32.1	46.0	-13.9	74	3.11
453.9700	3.01	17.34	8.8	29.2	46.0	-16.8	243	2.69

Antenna Polarization:Vertical

Frequency (MHz)	Cable Loss (dB)	Antenna Factor (dB/m)	Reading Data (dBμV)	Emission Level (dBμV/m)	Limit (dBμV/m)	Margin (dB)	AZ(°)	EL(m)
70.5600	1.20	8.00	15.8	25.0	40.0	-15.0	151	1.13
137.8500	1.67	12.67	9.9	24.2	43.5	-19.3	273	1.33
199.6600	1.90	11.71	10.9	24.5	43.5	-19.0	189	1.52
290.4800	2.40	13.30	14.2	29.9	46.0	-16.1	111	1.81
352.2900	2.61	15.15	10.9	28.7	46.0	-17.3	159	2.00
473.2200	3.09	17.62	10.2	30.9	46.0	-15.1	34	2.37

NOTE :

1. Measurement uncertainty is ±4.73dB.
2. "": Measurement does not apply for this frequency.
3. Emission Level = Reading Value + Ant. Factor + Cable Loss.
4. The field strength of other emission frequencies were very low against the limit.



**Spectrum Research
& Testing Lab., Inc.**
No.167,Ln. 780, Shan-Tong
Rd.,Ling 8, Shan-Tong Li,
Chung-Li City, Taoyuan County
320, Taiwan (R.O.C.)

TEST REPORT

Reference No.: A12030215
Report No.: FCCA12030215
FCC ID: JY8DW06
Page:28 of 82
Date: Apr. 24, 2012

Temperature:	<u>23 °C</u>	Humidity:	<u>57 %RH</u>
Frequency Range:	<u>30 – 1000 MHz</u>	Measured Distance:	<u>3m</u>
Receiver Detector:	<u>Q.P.</u>	Tested Mode:	<u>11B_CH11</u>
Tested By:	<u>Jeff Lo</u>	Tested Date:	<u>Apr. 12, 2012</u>

Antenna Polarization : Horizontal

Frequency (MHz)	Cable Loss (dB)	Antenna Factor (dB/m)	Reading Data (dBμV)	Emission Level (dBμV/m)	Limit (dBμV/m)	Margin (dB)	AZ(°)	EL(m)
68.1400	1.20	8.30	9.9	19.4	40.0	-20.6	204	3.88
199.6400	1.90	11.71	14.6	28.2	43.5	-15.3	119	3.48
317.1100	2.47	14.31	15.5	32.3	46.0	-13.7	147	3.11
352.2900	2.61	15.15	7.8	25.6	46.0	-20.4	10	3.00
453.8800	3.01	17.34	9.4	29.8	46.0	-16.2	33	2.69
479.5300	3.12	17.71	8.4	29.2	46.0	-16.8	74	2.61

Antenna Polarization:Vertical

Frequency (MHz)	Cable Loss (dB)	Antenna Factor (dB/m)	Reading Data (dBμV)	Emission Level (dBμV/m)	Limit (dBμV/m)	Margin (dB)	AZ(°)	EL(m)
53.4400	1.13	12.58	11.3	25.0	40.0	-15.0	351	1.07
63.2700	1.20	9.05	16.7	27.0	40.0	-13.1	313	1.10
68.1700	1.20	8.30	21.9	31.4	40.0	-8.6	222	1.12
77.4400	1.27	8.14	21.0	30.4	40.0	-9.6	207	1.15
159.9800	1.79	12.06	16.6	30.5	43.5	-13.1	255	1.40
297.3600	2.40	13.72	13.9	30.0	46.0	-16.0	144	1.83

NOTE :

1. Measurement uncertainty is ±4.73dB.
2. "": Measurement does not apply for this frequency.
3. Emission Level = Reading Value + Ant. Factor + Cable Loss.
4. The field strength of other emission frequencies were very low against the limit.



**Spectrum Research
& Testing Lab., Inc.**
No.167,Ln. 780, Shan-Tong
Rd.,Ling 8, Shan-Tong Li,
Chung-Li City, Taoyuan County
320, Taiwan (R.O.C.)

TEST REPORT

Reference No.: A12030215
Report No.: FCCA12030215
FCC ID: JY8DW06
Page:29 of 82
Date: Apr. 24, 2012

Temperature:	<u>23 °C</u>	Humidity:	<u>57 %RH</u>
Frequency Range:	<u>30 – 1000 MHz</u>	Measured Distance:	<u>3m</u>
Receiver Detector:	<u>Q.P.</u>	Tested Mode:	<u>11G_CH1</u>
Tested By:	<u>Jeff Lo</u>	Tested Date:	<u>Apr. 12, 2012</u>

Antenna Polarization : Horizontal

Frequency (MHz)	Cable Loss (dB)	Antenna Factor (dB/m)	Reading Data (dBμV)	Emission Level (dBμV/m)	Limit (dBμV/m)	Margin (dB)	AZ(°)	EL(m)
70.5600	1.20	8.00	11.9	21.1	40.0	-18.9	23	3.87
159.9800	1.79	12.06	10.1	24.0	43.5	-19.6	222	3.60
206.5400	1.96	12.04	14.1	28.1	43.5	-15.4	357	3.45
305.9300	2.42	14.02	14.5	30.9	46.0	-15.1	159	3.15
454.7700	3.02	17.36	9.2	29.6	46.0	-16.4	133	2.69
478.0300	3.11	17.69	7.7	28.5	46.0	-17.5	44	2.61

Antenna Polarization:Vertical

Frequency (MHz)	Cable Loss (dB)	Antenna Factor (dB/m)	Reading Data (dBμV)	Emission Level (dBμV/m)	Limit (dBμV/m)	Margin (dB)	AZ(°)	EL(m)
70.5300	1.20	8.00	15.9	25.1	40.0	-14.9	266	1.13
125.4900	1.55	12.25	11.1	24.9	43.5	-18.6	133	1.30
194.1800	1.90	11.26	11.1	24.3	43.5	-19.2	258	1.51
299.7500	2.40	13.84	13.5	29.7	46.0	-16.3	11	1.83
350.0110	2.60	15.10	10.7	28.4	46.0	-17.6	202	1.99
473.2900	3.09	17.62	11.2	31.9	46.0	-14.1	138	2.37

NOTE :

1. Measurement uncertainty is ±4.73dB.
2. "": Measurement does not apply for this frequency.
3. Emission Level = Reading Value + Ant. Factor + Cable Loss.
4. The field strength of other emission frequencies were very low against the limit.



TEST REPORT

Temperature:	23 °C	Humidity:	57 %RH
Frequency Range:	30 – 1000 MHz	Measured Distance:	3m
Receiver Detector:	Q.P.	Tested Mode:	11G_CH7
Tested By:	Jeff Lo	Tested Date:	Apr. 12, 2012

Antenna Polarization : Horizontal

Frequency (MHz)	Cable Loss (dB)	Antenna Factor (dB/m)	Reading Data (dBμV)	Emission Level (dBμV/m)	Limit (dBμV/m)	Margin (dB)	AZ(°)	EL(m)
68.1100	1.20	8.30	19.7	29.2	40.0	-10.8	144	3.88
159.4400	1.79	12.06	17.7	31.6	43.5	-12.0	303	3.60
211.3800	2.00	12.30	13.5	27.8	43.5	-15.7	211	3.44
276.9200	2.30	13.24	15.0	30.5	46.0	-15.5	37	3.24
306.9300	2.42	14.04	16.2	32.7	46.0	-13.3	42	3.14
457.8800	3.03	17.40	11.6	32.0	46.0	-14.0	59	2.68

Antenna Polarization: Vertical

Frequency (MHz)	Cable Loss (dB)	Antenna Factor (dB/m)	Reading Data (dBμV)	Emission Level (dBμV/m)	Limit (dBμV/m)	Margin (dB)	AZ(°)	EL(m)
68.1400	1.20	8.30	18.9	28.4	40.0	-11.6	148	1.12
137.8500	1.67	12.67	10.4	24.7	43.5	-18.8	150	1.33
159.4700	1.79	12.06	14.2	28.1	43.5	-15.5	266	1.40
299.7500	2.40	13.84	13.0	29.2	46.0	-16.8	161	1.83
349.1800	2.60	15.08	9.8	27.5	46.0	-18.5	164	1.99
473.2900	3.09	17.62	9.8	30.5	46.0	-15.5	174	2.37

NOTE :

1. Measurement uncertainty is ± 4.73 dB.
2. "*": Measurement does not apply for this frequency.
3. Emission Level = Reading Value + Ant. Factor + Cable Loss.
4. The field strength of other emission frequencies were very low against the limit.



**Spectrum Research
& Testing Lab., Inc.**
No.167,Ln. 780, Shan-Tong
Rd.,Ling 8, Shan-Tong Li,
Chung-Li City, Taoyuan County
320, Taiwan (R.O.C.)

TEST REPORT

Reference No.: A12030215
Report No.: FCCA12030215
FCC ID: JY8DW06
Page:31 of 82
Date: Apr. 24, 2012

Temperature:	<u>23 °C</u>	Humidity:	<u>57 %RH</u>
Frequency Range:	<u>30 – 1000 MHz</u>	Measured Distance:	<u>3m</u>
Receiver Detector:	<u>Q.P.</u>	Tested Mode:	<u>11G_CH11</u>
Tested By:	<u>Jeff Lo</u>	Tested Date:	<u>Apr. 12, 2012</u>

Antenna Polarization : Horizontal

Frequency (MHz)	Cable Loss (dB)	Antenna Factor (dB/m)	Reading Data (dBμV)	Emission Level (dBμV/m)	Limit (dBμV/m)	Margin (dB)	AZ(°)	EL(m)
68.1500	1.20	8.30	19.6	29.1	40.0	-10.9	233	3.88
159.4800	1.79	12.06	17.3	31.2	43.5	-12.4	108	3.60
194.3300	1.90	11.26	17.8	31.0	43.5	-12.5	11	3.49
317.1900	2.47	14.31	18.1	34.9	46.0	-11.1	244	3.11
453.5500	3.01	17.34	11.2	31.6	46.0	-14.4	36	2.69
477.8500	3.11	17.68	9.8	30.6	46.0	-15.4	147	2.61

Antenna Polarization:Vertical

Frequency (MHz)	Cable Loss (dB)	Antenna Factor (dB/m)	Reading Data (dBμV)	Emission Level (dBμV/m)	Limit (dBμV/m)	Margin (dB)	AZ(°)	EL(m)
70.5900	1.20	8.00	15.4	24.6	40.0	-15.4	258	1.13
137.8400	1.67	12.67	10.1	24.4	43.5	-19.1	21	1.33
165.1700	1.80	11.50	10.7	24.0	43.5	-19.5	31	1.42
201.6600	1.91	11.84	10.0	23.8	43.5	-19.8	131	1.53
294.2900	2.40	13.54	14.4	30.3	46.0	-15.7	159	1.82
478.3800	3.11	17.69	11.0	31.8	46.0	-14.2	322	2.39

NOTE :

1. Measurement uncertainty is ±4.73dB.
2. "*": Measurement does not apply for this frequency.
3. Emission Level = Reading Value + Ant. Factor + Cable Loss.
4. The field strength of other emission frequencies were very low against the limit.



**Spectrum Research
& Testing Lab., Inc.**
No.167,Ln. 780, Shan-Tong
Rd.,Ling 8, Shan-Tong Li,
Chung-Li City, Taoyuan County
320, Taiwan (R.O.C.)

TEST REPORT

Reference No.: A12030215
Report No.: FCCA12030215
FCC ID: JY8DW06
Page:32 of 82
Date: Apr. 24, 2012

Temperature:	<u>23 °C</u>	Humidity:	<u>57 %RH</u>
Frequency Range:	<u>30 – 1000 MHz</u>	Measured Distance:	<u>3m</u>
Receiver Detector:	<u>Q.P.</u>	Tested Mode:	<u>11N_CH5</u>
Tested By:	<u>Jeff Lo</u>	Tested Date:	<u>Apr. 12, 2012</u>

Antenna Polarization : Horizontal

Frequency (MHz)	Cable Loss (dB)	Antenna Factor (dB/m)	Reading Data (dBμV)	Emission Level (dBμV/m)	Limit (dBμV/m)	Margin (dB)	AZ(°)	EL(m)
159.9800	1.79	12.06	9.7	23.6	43.5	-20.0	222	3.60
206.5400	1.96	12.04	16.3	30.3	43.5	-13.2	133	3.45
276.9200	2.30	13.24	12.9	28.4	46.0	-17.6	206	3.24
317.1300	2.47	14.31	16.0	32.8	46.0	-13.2	15	3.11
453.8100	3.01	17.34	9.2	29.6	46.0	-16.4	247	2.69
477.5100	3.11	17.68	8.5	29.3	46.0	-16.7	73	2.62

Antenna Polarization:Vertical

Frequency (MHz)	Cable Loss (dB)	Antenna Factor (dB/m)	Reading Data (dBμV)	Emission Level (dBμV/m)	Limit (dBμV/m)	Margin (dB)	AZ(°)	EL(m)
52.4400	1.12	13.02	12.8	26.9	40.0	-13.1	100	1.07
70.5600	1.20	8.00	23.7	32.9	40.0	-7.1	199	1.13
80.5300	1.30	8.20	20.9	30.4	40.0	-9.6	248	1.16
159.3900	1.79	12.06	17.3	31.2	43.5	-12.4	33	1.40
304.2400	2.42	14.00	13.5	29.9	46.0	-16.1	202	1.85
477.5300	3.11	17.68	14.3	35.1	46.0	-10.9	338	2.38

NOTE :

1. Measurement uncertainty is ±4.73dB.
2. "**": Measurement does not apply for this frequency.
3. Emission Level = Reading Value + Ant. Factor + Cable Loss.
4. The field strength of other emission frequencies were very low against the limit.



**Spectrum Research
& Testing Lab., Inc.**
No.167, Ln. 780, Shan-Tong
Rd., Ling 8, Shan-Tong Li,
Chung-Li City, Taoyuan County
320, Taiwan (R.O.C.)

TEST REPORT

Reference No.: A12030215
Report No.: FCCA12030215
FCC ID: JY8DW06
Page: 33 of 82
Date: Apr. 24, 2012

Temperature:	<u>23 °C</u>	Humidity:	<u>57 %RH</u>
Frequency Range:	<u>30 – 1000 MHz</u>	Measured Distance:	<u>3m</u>
Receiver Detector:	<u>Q.P.</u>	Tested Mode:	<u>11N_CH8</u>
Tested By:	<u>Jeff Lo</u>	Tested Date:	<u>Apr. 12, 2012</u>

Antenna Polarization : Horizontal

Frequency (MHz)	Cable Loss (dB)	Antenna Factor (dB/m)	Reading Data (dBμV)	Emission Level (dBμV/m)	Limit (dBμV/m)	Margin (dB)	AZ(°)	EL(m)
159.9800	1.79	12.06	10.3	24.2	43.5	-19.4	254	3.60
206.4400	1.96	12.04	16.3	30.3	43.5	-13.2	133	3.45
280.1300	2.30	13.20	14.7	30.2	46.0	-15.8	111	3.23
317.4400	2.47	14.31	15.8	32.6	46.0	-13.4	109	3.11
453.5600	3.01	17.34	9.3	29.7	46.0	-16.3	307	2.69
473.8800	3.09	17.62	11.3	32.0	46.0	-14.0	275	2.63

Antenna Polarization: Vertical

Frequency (MHz)	Cable Loss (dB)	Antenna Factor (dB/m)	Reading Data (dBμV)	Emission Level (dBμV/m)	Limit (dBμV/m)	Margin (dB)	AZ(°)	EL(m)
70.6500	1.20	8.00	19.0	28.2	40.0	-11.8	155	1.13
159.9500	1.79	12.06	13.5	27.4	43.5	-16.2	254	1.40
199.3700	1.90	11.71	11.3	24.9	43.5	-18.6	158	1.52
213.4400	2.00	12.50	10.5	25.0	43.5	-18.5	259	1.57
292.8700	2.40	13.42	13.8	29.6	46.0	-16.4	101	1.81
349.1100	2.60	15.08	10.9	28.6	46.0	-17.4	165	1.99

NOTE :

1. Measurement uncertainty is ±4.73dB.
2. "**": Measurement does not apply for this frequency.
3. Emission Level = Reading Value + Ant. Factor + Cable Loss.
4. The field strength of other emission frequencies were very low against the limit.



**Spectrum Research
& Testing Lab., Inc.**
No.167, Ln. 780, Shan-Tong
Rd., Ling 8, Shan-Tong Li,
Chung-Li City, Taoyuan County
320, Taiwan (R.O.C.)

TEST REPORT

Reference No.: A12030215
Report No.: FCCA12030215
FCC ID: JY8DW06
Page: 34 of 82
Date: Apr. 24, 2012

Temperature:	23 °C	Humidity:	57 %RH
Frequency Range:	30 – 1000 MHz	Measured Distance:	3m
Receiver Detector:	Q.P.	Tested Mode:	11N_CH11
Tested By:	Jeff Lo	Tested Date:	Apr. 12, 2012

Antenna Polarization : Horizontal

Frequency (MHz)	Cable Loss (dB)	Antenna Factor (dB/m)	Reading Data (dBμV)	Emission Level (dBμV/m)	Limit (dBμV/m)	Margin (dB)	AZ(°)	EL(m)
68.6800	1.20	8.30	18.9	28.4	40.0	-11.6	44	3.88
159.7300	1.79	12.06	15.8	29.7	43.5	-13.9	241	3.60
206.5500	1.96	12.04	18.9	32.9	43.5	-10.6	259	3.45
281.4100	2.31	13.21	14.6	30.1	46.0	-15.9	222	3.22
317.6900	2.47	14.31	18.5	35.3	46.0	-10.7	307	3.11
477.8800	3.11	17.68	9.9	30.7	46.0	-15.3	38	2.61

Antenna Polarization: Vertical

Frequency (MHz)	Cable Loss (dB)	Antenna Factor (dB/m)	Reading Data (dBμV)	Emission Level (dBμV/m)	Limit (dBμV/m)	Margin (dB)	AZ(°)	EL(m)
70.5600	1.20	8.00	18.9	28.1	40.0	-11.9	101	1.13
159.7500	1.79	12.06	13.3	27.2	43.5	-16.4	22	1.40
206.5800	1.96	12.04	11.6	25.6	43.5	-17.9	99	1.55
299.7500	2.40	13.84	13.9	30.1	46.0	-15.9	293	1.83
347.1100	2.59	15.03	10.9	28.5	46.0	-17.5	107	1.98
477.8500	3.11	17.68	5.5	26.3	46.0	-19.7	214	2.39

NOTE :

1. Measurement uncertainty is ±4.73dB.
2. "**": Measurement does not apply for this frequency.
3. Emission Level = Reading Value + Ant. Factor + Cable Loss.
4. The field strength of other emission frequencies were very low against the limit.



TEST REPORT

Temperature:	23 °C	Humidity:	57 %RH
Frequency Range:	1 – 25 GHz	Measured Distance:	3m
Receiver Detector:	PK. or AV.	Tested Mode:	11B
Tested By:	Jeff Lo	Tested Channel:	2412 MHz
Tested Date:	Apr. 12, 2012	Modulation Type:	QPSK

Antenna Polarization : Horizontal

Frequency (MHz)	Correct Factor (dB)	Ant. Factor (dB/m)	Reading Data (dBµV)		Emission Level (dBµV/m)		Limit (dBµV/m)		Margin (dB)		AZ (°)	EL (m)
			PK.	AV.	PK.	AV.	PK.	AV.	PK.	AV.		
2412.00	-33.88	28.11	95.3	84.3	89.5	78.6	114	94.0	-24.5	-15.4	344	2.08
2463.48	-33.87	28.22	49.1	38.4	43.5	32.7	74.0	54.0	-30.5	-21.3	297	2.06
2732.44	-33.80	29.14	43.8	32.7	39.2	28.0	74.0	54.0	-34.8	-26.0	288	1.98
3122.69	-33.64	30.34	46.1	35.9	42.8	32.6	74.0	54.0	-31.2	-21.4	289	1.86
4107.86	-33.11	32.42	44.7	33.3	44.0	32.6	74.0	54.0	-30.0	-21.4	174	1.57
4997.11	-32.79	33.39	42.1	31.3	42.7	31.9	74.0	54.0	-31.3	-22.1	71	1.30

Antenna Polarization : Vertical

Frequency (MHz)	Correct Factor (dB)	Ant. Factor (dB/m)	Reading Data (dBµV)		Emission Level (dBµV/m)		Limit (dBµV/m)		Margin (dB)		AZ (°)	EL (m)
			PK.	AV.	PK.	AV.	PK.	AV.	PK.	AV.		
2412.00	-33.88	28.11	103.8	91.2	98.0	85.4	114	94.0	-16.0	-8.6	252	1.42
1927.49	-34.06	26.94	56.0	45.4	48.9	38.3	74.0	54.0	-25.1	-15.7	121	1.28
2377.64	-33.89	28.03	55.4	43.8	49.5	37.9	74.0	54.0	-24.5	-16.1	205	1.41
3137.91	-33.63	30.37	46.0	36.9	42.7	33.6	74.0	54.0	-31.3	-20.4	189	1.64
3832.47	-33.22	31.96	44.3	33.5	43.1	32.2	74.0	54.0	-30.9	-21.8	277	1.85
4997.15	-32.79	33.39	43.5	32.1	44.1	32.7	74.0	54.0	-29.9	-21.3	263	2.20

NOTE :

1. Measurement uncertainty is ± 3.7 dB.
2. "": The Peak reading value also meets average limit and measurement with the average detector is unnecessary.
3. Emission Level = Reading Value + Ant. Factor + Correct Factor (incl.:Cable Loss and Pre-Amplifier Gain)
4. The field strength of other emission frequencies were very low against the limit.
5. (F):The field strength of fundamental frequency.



TEST REPORT

Temperature:	23 °C	Humidity:	57 %RH
Frequency Range:	1 – 25 GHz	Measured Distance:	3m
Receiver Detector:	PK. or AV.	Tested Mode:	11B
Tested By:	Jeff Lo	Tested Channel:	CH7 : 2442 MHz
Tested Date:	Apr. 12, 2012	Modulation Type:	QPSK

Antenna Polarization : Horizontal

Frequency (MHz)	Correct Factor (dB)	Ant. Factor (dB/m)	Reading Data (dBμV)		Emission Level (dBμV/m)		Limit (dBμV/m)		Margin (dB)		AZ (°)	EL (m)
			PK.	AV.	PK.	AV.	PK.	AV.	PK.	AV.		
2442.00	-33.87	28.17	87.3	75.4	81.6	69.6	114	94.0	-32.4	-24.4	336	2.07
1232.41	-35.18	24.76	55.1	44.4	44.6	34.0	74.0	54.0	-29.4	-20.0	242	2.43
1287.64	-35.05	24.89	54.5	33.1	44.3	23.0	74.0	54.0	-29.7	-31.0	42	2.41
3232.23	-33.55	30.56	46.9	35.9	43.9	32.9	74.0	54.0	-30.1	-21.1	288	1.83
4422.59	-32.95	32.48	43.7	32.6	43.3	32.1	74.0	54.0	-30.7	-21.9	169	1.47
4997.88	-32.79	33.39	42.3	30.6	42.9	31.2	74.0	54.0	-31.1	-22.8	71	1.30

Antenna Polarization : Vertical

Frequency (MHz)	Correct Factor (dB)	Ant. Factor (dB/m)	Reading Data (dBμV)		Emission Level (dBμV/m)		Limit (dBμV/m)		Margin (dB)		AZ (°)	EL (m)
			PK.	AV.	PK.	AV.	PK.	AV.	PK.	AV.		
2442.00	-33.87	28.17	100.2	89.7	94.5	84.0	114	94.0	-19.5	-10.0	249	1.43
1212.38	-35.23	24.71	55.1	35.5	44.6	25.0	74.0	54.0	-29.4	-29.0	131	1.06
1287.69	-35.05	24.89	53.8	33.8	43.6	23.6	74.0	54.0	-30.4	-30.4	129	1.09
3612.23	-33.30	31.39	44.6	33.6	42.7	31.7	74.0	54.0	-31.3	-22.3	180	1.78
4882.64	-32.82	33.19	51.2	40.3	51.5	40.7	74.0	54.0	-22.5	-13.3	272	2.16
4997.85	-32.79	33.39	43.4	32.2	44.0	32.8	74.0	54.0	-30.0	-21.2	262	2.20

NOTE :

1. Measurement uncertainty is ±3.7dB.
2. "": The Peak reading value also meets average limit and measurement with the average detector is unnecessary.
3. Emission Level = Reading Value + Ant. Factor + Correct Factor (incl.:Cable Loss and Pre-Amplifier Gain)
4. The field strength of other emission frequencies were very low against the limit.
5. (F):The field strength of fundamental frequency.



TEST REPORT

Temperature:	23 °C	Humidity:	57 %RH
Frequency Range:	1 – 25 GHz	Measured Distance:	3m
Receiver Detector:	PK. or AV.	Tested Mode:	11B
Tested By:	Jeff Lo	Tested Channel:	CH11 : 2462 MHz
Tested Date:	Apr. 12, 2012	Modulation Type:	QPSK

Antenna Polarization : Horizontal

Frequency (MHz)	Correct Factor (dB)	Ant. Factor (dB/m)	Reading Data (dBµV)		Emission Level (dBµV/m)		Limit (dBµV/m)		Margin (dB)		AZ (°)	EL (m)
			PK.	AV.	PK.	AV.	PK.	AV.	PK.	AV.		
2462.00	-33.87	28.24	88.4	77.7	82.7	72.1	114	94.0	-31.3	-21.9	337	2.06
1997.63	-33.98	27.19	56.0	46.3	49.2	39.5	74.0	54.0	-24.8	-14.5	41	2.20
2114.59	-33.95	27.45	53.3	42.1	46.8	35.6	74.0	54.0	-27.2	-18.4	306	2.17
2457.11	-33.87	28.21	53.3	42.5	47.7	36.8	74.0	54.0	-26.3	-17.2	302	2.06
4102.55	-33.11	32.42	44.7	32.3	44.0	31.6	74.0	54.0	-30.0	-22.4	174	1.57
4997.82	-32.79	33.39	42.3	32.2	42.9	32.8	74.0	54.0	-31.1	-21.2	211	1.30

Antenna Polarization : Vertical

Frequency (MHz)	Correct Factor (dB)	Ant. Factor (dB/m)	Reading Data (dBµV)		Emission Level (dBµV/m)		Limit (dBµV/m)		Margin (dB)		AZ (°)	EL (m)
			PK.	AV.	PK.	AV.	PK.	AV.	PK.	AV.		
2462.00	-33.87	28.24	94.1	83.1	88.4	77.5	114	94.0	-25.6	-16.5	242	1.44
1997.66	-33.98	27.19	55.7	45.3	48.9	38.5	74.0	54.0	-25.1	-15.5	121	1.30
2407.16	-33.88	28.10	54.8	34.6	49.0	28.8	74.0	54.0	-25.0	-25.2	203	1.42
4307.91	-33.01	32.46	44.4	33.7	43.9	33.2	74.0	54.0	-30.1	-20.8	271	1.99
4997.85	-32.79	33.39	43.2	32.9	43.8	33.5	74.0	54.0	-30.2	-20.5	338	2.20
5692.44	-32.63	33.88	43.4	31.2	44.7	32.4	74.0	54.0	-29.3	-21.6	354	2.41

NOTE :

1. Measurement uncertainty is ± 3.7 dB.
2. "**": The Peak reading value also meets average limit and measurement with the average detector is unnecessary.
3. Emission Level = Reading Value + Ant. Factor + Correct Factor (incl.:Cable Loss and Pre-Amplifier Gain)
4. The field strength of other emission frequencies were very low against the limit.
5. (F):The field strength of fundamental frequency.



TEST REPORT

Temperature:	23 °C	Humidity:	57 %RH
Frequency Range:	1 – 25 GHz	Measured Distance:	3m
Receiver Detector:	PK. or AV.	Tested Mode:	11G
Tested By:	Jeff Lo	Tested Channel:	CH1:2412 MHz
Tested Date:	Apr. 12, 2012	Modulation Type:	OFDM

Antenna Polarization : Horizontal

Frequency (MHz)	Correct Factor (dB)	Ant. Factor (dB/m)	Reading Data (dBµV)		Emission Level (dBµV/m)		Limit (dBµV/m)		Margin (dB)		AZ (°)	EL (m)
			PK.	AV.	PK.	AV.	PK.	AV.	PK.	AV.		
2412.00	-33.88	28.11	87.6	76.6	81.8	70.8	114	94.0	-32.2	-23.2	336	2.08
2457.64	-33.87	28.21	51.0	40.4	45.3	34.7	74.0	54.0	-28.7	-19.3	299	2.06
3117.81	-33.65	30.33	46.9	35.8	43.6	32.5	74.0	54.0	-30.4	-21.5	290	1.86
3987.45	-33.16	32.37	45.0	34.3	44.2	33.5	74.0	54.0	-29.8	-20.5	176	1.60
4652.31	-32.87	32.77	44.9	33.3	44.8	33.2	74.0	54.0	-29.2	-20.8	168	1.40
4997.55	-32.79	33.39	41.5	30.9	42.1	31.5	74.0	54.0	-31.9	-22.5	71	1.30

Antenna Polarization : Vertical

Frequency (MHz)	Correct Factor (dB)	Ant. Factor (dB/m)	Reading Data (dBµV)		Emission Level (dBµV/m)		Limit (dBµV/m)		Margin (dB)		AZ (°)	EL (m)
			PK.	AV.	PK.	AV.	PK.	AV.	PK.	AV.		
2412.00	-33.88	28.11	95.7	84.3	89.9	78.5	114	94.0	-24.1	-15.5	244	1.42
1997.48	-33.98	27.19	55.5	45.7	48.7	38.9	74.0	54.0	-25.3	-15.1	120	1.30
2457.66	-33.87	28.21	52.9	41.8	47.2	36.1	74.0	54.0	-26.8	-17.9	201	1.44
3167.83	-33.61	30.43	46.3	35.9	43.1	32.7	74.0	54.0	-30.9	-21.3	189	1.65
4033.24	-33.14	32.41	45.4	34.6	44.7	33.9	74.0	54.0	-29.3	-20.1	276	1.91
4752.44	-32.85	32.95	43.6	32.3	43.7	32.4	74.0	54.0	-30.3	-21.6	265	2.13

NOTE :

1. Measurement uncertainty is ±3.7dB.
2. "**": The Peak reading value also meets average limit and measurement with the average detector is unnecessary.
3. Emission Level = Reading Value + Ant. Factor + Correct Factor (incl.:Cable Loss and Pre-Amplifier Gain)
4. The field strength of other emission frequencies were very low against the limit.
5. (F):The field strength of fundamental frequency.



TEST REPORT

Temperature:	23 °C	Humidity:	57 %RH
Frequency Range:	1 – 25 GHz	Measured Distance:	3m
Receiver Detector:	PK. or AV.	Tested Mode:	11G
Tested By:	Jeff Lo	Tested Channel:	CH7: 2442 MHz
Tested Date:	Apr. 12, 2012	Modulation Type:	OFDM

Antenna Polarization : Horizontal

Frequency (MHz)	Correct Factor (dB)	Ant. Factor (dB/m)	Reading Data (dBµV)		Emission Level (dBµV/m)		Limit (dBµV/m)		Margin (dB)		AZ (°)	EL (m)
			PK.	AV.	PK.	AV.	PK.	AV.	PK.	AV.		
2442.00	-33.87	28.17	102.5	91.6	96.8	85.9	114	94.0	-17.2	-8.1	351	2.07
2002.17	-33.98	27.20	53.6	42.1	46.8	35.3	74.0	54.0	-27.2	-18.7	199	2.20
3402.45	-33.42	30.90	44.1	34.1	41.6	31.6	74.0	54.0	-32.4	-22.4	183	1.78
4427.69	-32.95	32.49	44.1	33.9	43.7	33.4	74.0	54.0	-30.3	-20.6	170	1.47
4882.64	-32.82	33.19	49.6	36.8	50.0	37.2	74.0	54.0	-24.0	-16.8	80	1.34
4997.48	-32.79	33.39	41.8	31.6	42.4	32.2	74.0	54.0	-31.6	-21.8	151	1.30

Antenna Polarization : Vertical

Frequency (MHz)	Correct Factor (dB)	Ant. Factor (dB/m)	Reading Data (dBµV)		Emission Level (dBµV/m)		Limit (dBµV/m)		Margin (dB)		AZ (°)	EL (m)
			PK.	AV.	PK.	AV.	PK.	AV.	PK.	AV.		
2442.00	-33.87	28.17	99.5	87.7	93.8	82.0	114	94.0	-20.2	-12.0	248	1.43
1327.56	-34.96	24.98	53.8	42.4	43.8	32.4	74.0	54.0	-30.2	-21.6	128	1.10
1997.48	-33.98	27.19	55.1	35.8	48.3	29.0	74.0	54.0	-25.7	-25.0	120	1.30
2502.38	-33.86	28.31	49.0	36.6	43.4	31.0	74.0	54.0	-30.6	-23.0	196	1.45
2662.78	-33.82	28.88	46.6	35.9	41.7	31.0	74.0	54.0	-32.3	-23.0	192	1.50
3797.38	-33.23	31.87	46.5	35.2	45.1	33.8	74.0	54.0	-28.9	-20.2	281	1.84

NOTE :

1. Measurement uncertainty is ± 3.7 dB.
2. "*": The Peak reading value also meets average limit and measurement with the average detector is unnecessary.
3. Emission Level = Reading Value + Ant. Factor + Correct Factor (incl.:Cable Loss and Pre-Amplifier Gain)
4. The field strength of other emission frequencies were very low against the limit.
5. (F):The field strength of fundamental frequency.



TEST REPORT

Temperature:	23 °C	Humidity:	57 %RH
Frequency Range:	1 – 25 GHz	Measured Distance:	3m
Receiver Detector:	PK. or AV.	Tested Mode:	11G
Tested By:	Jeff Lo	Tested Channel:	CH11: 2462 MHz
Tested Date:	Apr. 12, 2012	Modulation Type:	OFDM

Antenna Polarization : Horizontal

Frequency (MHz)	Correct Factor (dB)	Ant. Factor (dB/m)	Reading Data (dBµV)		Emission Level (dBµV/m)		Limit (dBµV/m)		Margin (dB)		AZ (°)	EL (m)
			PK.	AV.	PK.	AV.	PK.	AV.	PK.	AV.		
2462.00	-33.87	28.24	94.0	83.9	88.4	78.3	114	94.0	-25.6	-15.7	342	2.06
2407.86	-33.88	28.10	50.9	40.4	45.1	34.6	74.0	54.0	-28.9	-19.4	299	2.08
4032.44	-33.14	32.41	44.9	34.2	44.2	33.5	74.0	54.0	-29.8	-20.5	175	1.59
4532.66	-32.90	32.56	44.7	34.4	44.3	34.1	74.0	54.0	-29.7	-19.9	169	1.44
4997.89	-32.79	33.39	43.3	32.2	43.9	32.8	74.0	54.0	-30.1	-21.2	72	1.30
5552.38	-32.62	33.82	42.9	31.7	44.0	32.9	74.0	54.0	-30.0	-21.1	64	1.13

Antenna Polarization : Vertical

Frequency (MHz)	Correct Factor (dB)	Ant. Factor (dB/m)	Reading Data (dBµV)		Emission Level (dBµV/m)		Limit (dBµV/m)		Margin (dB)		AZ (°)	EL (m)
			PK.	AV.	PK.	AV.	PK.	AV.	PK.	AV.		
2462.00	-33.87	28.24	96.0	85.4	90.3	79.8	114	94.0	-23.7	-14.2	244	1.44
1992.48	-33.99	27.17	51.9	41.4	45.1	34.6	74.0	54.0	-28.9	-19.4	117	1.30
2407.83	-33.88	28.10	51.1	41.7	45.3	35.9	74.0	54.0	-28.7	-18.1	200	1.42
4822.73	-32.83	33.08	45.8	34.3	46.0	34.5	74.0	54.0	-28.0	-19.5	266	2.15
4967.11	-32.80	33.34	52.7	42.2	53.2	42.7	74.0	54.0	-20.8	-11.3	272	2.19
4997.85	-32.79	33.39	42.3	32.9	42.9	33.5	74.0	54.0	-31.1	-20.5	261	2.20

NOTE :

1. Measurement uncertainty is ± 3.7 dB.
2. "": The Peak reading value also meets average limit and measurement with the average detector is unnecessary.
3. Emission Level = Reading Value + Ant. Factor + Correct Factor (incl.:Cable Loss and Pre-Amplifier Gain)
4. The field strength of other emission frequencies were very low against the limit.
5. (F):The field strength of fundamental frequency.



TEST REPORT

Temperature:	23 °C	Humidity:	57 %RH
Frequency Range:	1 – 25 GHz	Measured Distance:	3m
Receiver Detector:	PK. or AV.	Tested Mode:	11N
Tested By:	Jeff Lo	Tested Channel:	CH5: 2422 MHz
Tested Date:	Apr. 12, 2012	Modulation Type:	OFDM

Antenna Polarization : Horizontal

Frequency (MHz)	Correct Factor (dB)	Ant. Factor (dB/m)	Reading Data (dBμV)		Emission Level (dBμV/m)		Limit (dBμV/m)		Margin (dB)		AZ (°)	EL (m)
			PK.	AV.	PK.	AV.	PK.	AV.	PK.	AV.		
2422.00	-33.88	28.13	102.7	91.4	96.9	85.7	114	94.0	-17.1	-8.3	351	2.07
3337.14	-33.47	30.77	44.7	34.1	42.0	31.4	74.0	54.0	-32.0	-22.6	184	1.80
3842.56	-33.22	31.99	45.2	34.2	44.0	33.0	74.0	54.0	-30.0	-21.0	178	1.65
4337.11	-32.99	32.47	43.6	33.2	43.0	32.7	74.0	54.0	-31.0	-21.3	170	1.50
5327.43	-32.68	33.66	42.7	31.9	43.6	32.9	74.0	54.0	-30.4	-21.1	67	1.20
5712.87	-32.63	33.88	43.2	30.3	44.4	31.6	74.0	54.0	-29.6	-22.4	63	1.09

Antenna Polarization : Vertical

Frequency (MHz)	Correct Factor (dB)	Ant. Factor (dB/m)	Reading Data (dBμV)		Emission Level (dBμV/m)		Limit (dBμV/m)		Margin (dB)		AZ (°)	EL (m)
			PK.	AV.	PK.	AV.	PK.	AV.	PK.	AV.		
2422.00	-33.88	28.13	103.1	92.4	97.3	86.7	114	94.0	-16.7	-7.3	251	1.43
3042.55	-33.71	30.18	45.1	33.8	41.5	30.3	74.0	54.0	-32.5	-23.7	189	1.61
3487.25	-33.35	31.07	44.1	32.2	41.8	29.9	74.0	54.0	-32.2	-24.1	182	1.75
3822.41	-33.22	31.94	44.6	33.1	43.3	31.8	74.0	54.0	-30.7	-22.2	278	1.85
4462.13	-32.93	32.49	43.5	32.8	43.1	32.3	74.0	54.0	-30.9	-21.7	269	2.04
5732.47	-32.63	33.89	42.7	31.5	44.0	32.8	74.0	54.0	-30.0	-21.2	352	2.42

NOTE :

1. Measurement uncertainty is ±3.7dB.
2. "": The Peak reading value also meets average limit and measurement with the average detector is unnecessary.
3. Emission Level = Reading Value + Ant. Factor + Correct Factor (incl.:Cable Loss and Pre-Amplifier Gain)
4. The field strength of other emission frequencies were very low against the limit.
5. (F):The field strength of fundamental frequency.



TEST REPORT

Temperature:	23 °C	Humidity:	57 %RH
Frequency Range:	1 – 25 GHz	Measured Distance:	3m
Receiver Detector:	PK. or AV.	Tested Mode:	11N
Tested By:	Jeff Lo	Tested Channel:	CH8: 2437 MHz
Tested Date:	Apr. 12, 2012	Modulation Type:	OFDM

Antenna Polarization : Horizontal

Frequency (MHz)	Correct Factor (dB)	Ant. Factor (dB/m)	Reading Data (dBµV)		Emission Level (dBµV/m)		Limit (dBµV/m)		Margin (dB)		AZ (°)	EL (m)
			PK.	AV.	PK.	AV.	PK.	AV.	PK.	AV.		
2437.00	-33.88	28.16	102.8	91.3	97.1	85.6	114	94.0	-16.9	-8.4	351	2.07
1922.38	-34.07	26.92	52.9	42.2	45.7	35.0	74.0	54.0	-28.3	-19.0	40	2.22
3767.64	-33.24	31.79	46.0	35.4	44.6	34.0	74.0	54.0	-29.4	-20.0	180	1.67
4277.12	-33.02	32.46	44.3	33.9	43.7	33.3	74.0	54.0	-30.3	-20.7	172	1.52
4697.55	-32.86	32.85	43.7	32.6	43.7	32.6	74.0	54.0	-30.3	-21.4	77	1.39
5732.61	-32.63	33.89	43.8	32.1	45.0	33.4	74.0	54.0	-29.0	-20.6	64	1.08

Antenna Polarization : Vertical

Frequency (MHz)	Correct Factor (dB)	Ant. Factor (dB/m)	Reading Data (dBµV)		Emission Level (dBµV/m)		Limit (dBµV/m)		Margin (dB)		AZ (°)	EL (m)
			PK.	AV.	PK.	AV.	PK.	AV.	PK.	AV.		
2437.00	-33.88	28.16	96.7	85.4	91.0	79.7	114	94.0	-23.0	-14.3	245	1.43
2372.88	-33.89	28.02	46.1	35.7	40.2	29.8	74.0	54.0	-33.8	-24.2	196	1.41
2567.44	-33.84	28.54	46.7	35.9	41.4	30.6	74.0	54.0	-32.6	-23.4	194	1.47
3097.31	-33.66	30.29	45.8	34.1	42.4	30.7	74.0	54.0	-31.6	-23.3	190	1.63
3502.71	-33.34	31.11	45.3	34.5	43.0	32.3	74.0	54.0	-31.0	-21.7	182	1.75
4902.33	-32.81	33.22	48.5	37.1	49.0	37.5	74.0	54.0	-25.0	-16.5	268	2.17

NOTE :

1. Measurement uncertainty is ± 3.7 dB.
2. "F": The Peak reading value also meets average limit and measurement with the average detector is unnecessary.
3. Emission Level = Reading Value + Ant. Factor + Correct Factor (incl.:Cable Loss and Pre-Amplifier Gain)
4. The field strength of other emission frequencies were very low against the limit.
5. (F):The field strength of fundamental frequency.



TEST REPORT

Temperature:	23 °C	Humidity:	57 %RH
Frequency Range:	1 – 25 GHz	Measured Distance:	3m
Receiver Detector:	PK. or AV.	Tested Mode:	11N
Tested By:	Jeff Lo	Tested Channel:	CH11: 2452 MHz
Tested Date:	Apr. 12, 2012	Modulation Type:	OFDM

Antenna Polarization : Horizontal

Frequency (MHz)	Correct Factor (dB)	Ant. Factor (dB/m)	Reading Data (dB μ V)		Emission Level (dB μ V/m)		Limit (dB μ V/m)		Margin (dB)		AZ (°)	EL (m)
			PK.	AV.	PK.	AV.	PK.	AV.	PK.	AV.		
2452.00	-33.87	28.22	100.2	89.9	94.5	84.2	114	94.0	-19.5	-9.8	348	2.06
1732.44	-34.29	26.24	50.4	40.1	42.4	32.0	74.0	54.0	-31.6	-22.0	40	2.28
3487.56	-33.35	31.07	44.6	33.8	42.4	31.5	74.0	54.0	-31.6	-22.5	183	1.75
4212.38	-33.05	32.44	43.9	32.9	43.3	32.3	74.0	54.0	-30.7	-21.7	172	1.54
4942.93	-32.80	33.30	51.4	40.5	51.9	41.0	74.0	54.0	-22.1	-13.0	81	1.32
5482.66	-32.63	33.79	42.3	32.1	43.5	33.3	74.0	54.0	-30.5	-20.7	65	1.16

Antenna Polarization : Vertical

Frequency (MHz)	Correct Factor (dB)	Ant. Factor (dB/m)	Reading Data (dB μ V)		Emission Level (dB μ V/m)		Limit (dB μ V/m)		Margin (dB)		AZ (°)	EL (m)
			PK.	AV.	PK.	AV.	PK.	AV.	PK.	AV.		
2452.00	-33.87	28.22	100.6	90.1	94.9	84.4	114	94.0	-19.1	-9.6	249	1.44
2762.82	-33.80	29.24	45.0	35.5	40.4	30.9	74.0	54.0	-33.6	-23.1	189	1.53
3442.21	-33.39	30.98	44.4	33.8	42.0	31.4	74.0	54.0	-32.0	-22.6	183	1.73
4117.11	-33.10	32.42	43.9	32.1	43.2	31.4	74.0	54.0	-30.8	-22.6	273	1.94
4422.74	-32.95	32.48	43.7	32.9	43.2	32.4	74.0	54.0	-30.8	-21.6	269	2.03
4942.49	-32.80	33.30	51.0	40.1	51.5	40.6	74.0	54.0	-22.5	-13.4	270	2.18

NOTE :

1. Measurement uncertainty is ± 3.7 dB.
2. "F": The Peak reading value also meets average limit and measurement with the average detector is unnecessary.
3. Emission Level = Reading Value + Ant. Factor + Correct Factor (incl.: Cable Loss and Pre-Amplifier Gain)
4. The field strength of other emission frequencies were very low against the limit.
5. (F): The field strength of fundamental frequency.



4.3 BANDWIDTH TEST

4.3.1 LIMIT

FCC Part15, Subpart C Section 15.247 (a)(2). The minimum 6dB bandwidth shall be at least 500 kHz.

4.3.2 TEST EQUIPMENT

The following test equipment was used during the test:

EQUIPMENT/FACILITIES	SPECIFICATIONS	MANUFACTURER	MODEL#/SERIAL#	DUE DATE OF CAL. & CAL. CENTER
SPECTRUM	9kHz-40GHz	ROHDE & SCHWARZ	FSP40/100093	Dec. 2012 ETC
EMI Test Receiver	9kHz-6GHz	ROHDE & SCHWARZ	ESL/100176	Mar. 2012 R&S

NOTE: The calibration interval of the above test equipment is one year and the calibrations are traceable to NML/ROC and NIST/USA.

4.3.3 TEST SET-UP

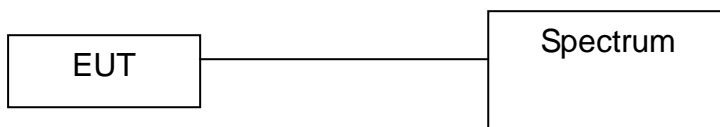

The EUT was connected to a spectrum through a 50Ω RF cable.

4.3.4 TEST PROCEDURE

The EUT was operated in continuous transmission mode on any specific channel. Printed out the test result from the spectrum by hard copy function.

4.3.5 EUT OPERATING CONDITION

1. Set the EUT under continuous transmission condition.
2. The EUT was set to the highest available power level.



Spectrum Research & Testing Lab., Inc.
 No.167, Ln. 780, Shan-Tong Rd., Ling 8, Shan-Tong Li, Chung-Li City, Taoyuan County 320, Taiwan (R.O.C.)

TEST REPORT

Reference No.: A12030215
 Report No.: FCCA12030215
 FCC ID: JY8DW06
 Page: 45 of 82
 Date: Apr. 24, 2012

4.3.6 TEST RESULT

Temperature:	22°C	Humidity:	51%RH
Spectrum Detector:	PK.	Tested Mode:	802.11b
Tested By:	Jeff Lo	Modulation Type:	QPSK
Tested Date:	Apr. 13, 2012		

CHANNEL NUMBER	CHANNEL FREQUENCY (MHz)	6dB DOWN BW (MHz)	Minimum Limit (MHz)
1	2412	10.28	0.5
7	2442	8.38	0.5
11	2462	9.78	0.5

CH1:

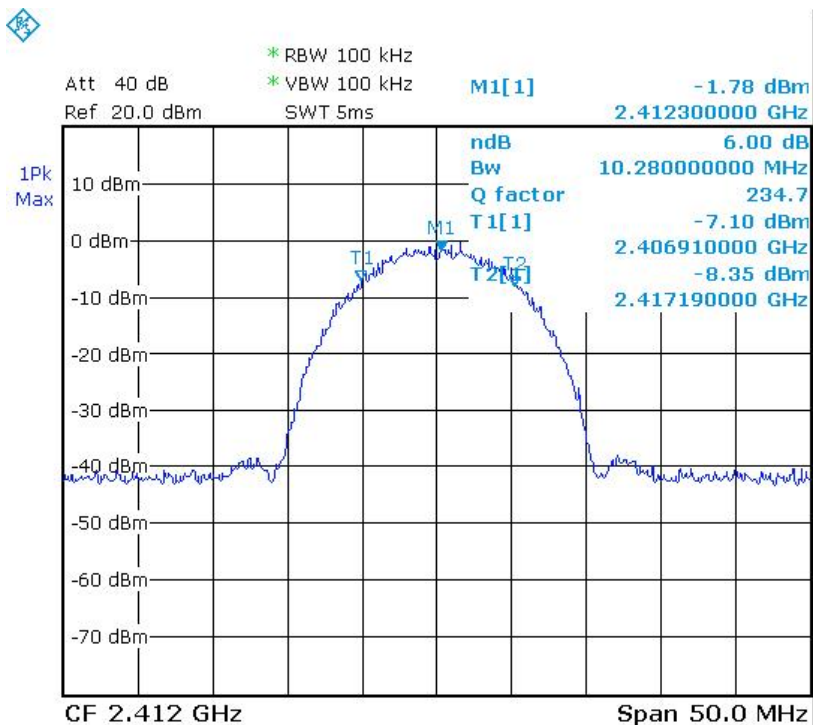



CH 7:

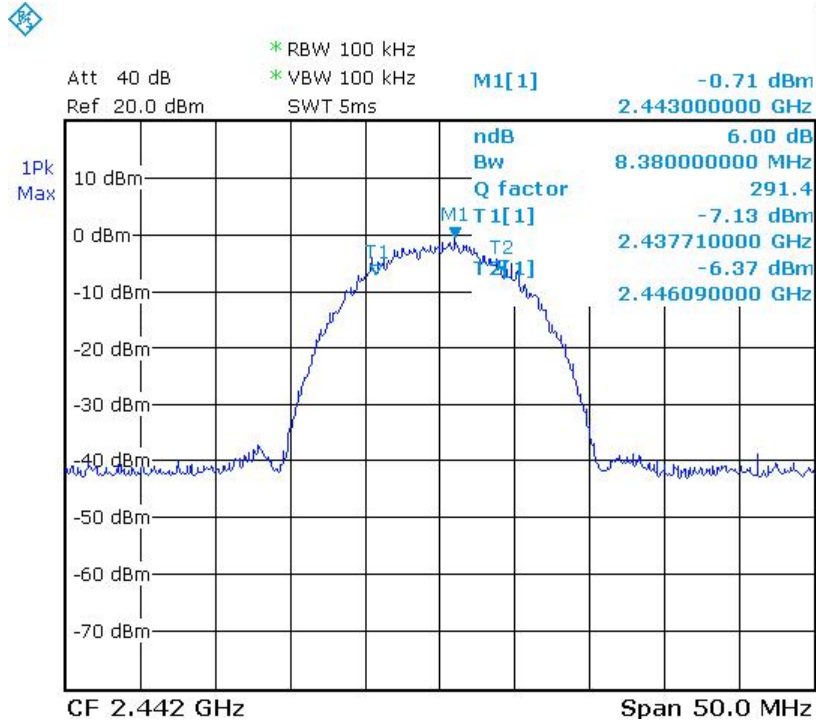

CH 13:

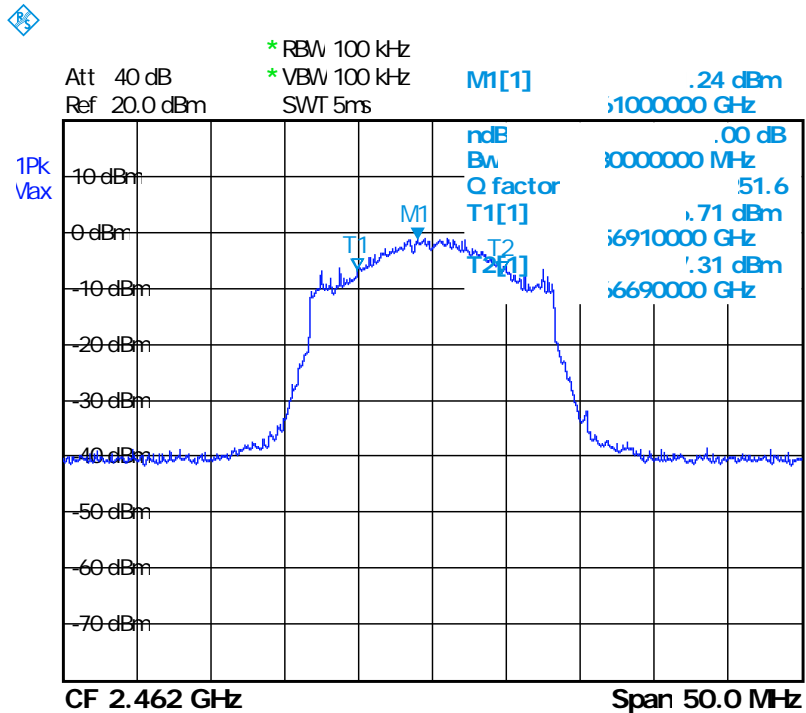



Spectrum Research & Testing Lab., Inc.
 No.167, Ln. 780, Shan-Tong Rd., Ling 8, Shan-Tong Li, Chung-Li City, Taoyuan County 320, Taiwan (R.O.C.)

TEST REPORT

Reference No.: A12030215
 Report No.: FCCA12030215
 FCC ID: JY8DW06
 Page: 47 of 82
 Date: Apr. 24, 2012

Temperature:	<u>22°C</u>	Humidity:	<u>51%RH</u>
Spectrum Detector:	<u>PK.</u>	Tested Mode:	<u>802.11g</u>
Tested By:	<u>Jeff Lo</u>	Modulation Type:	<u>64QAM</u>
Tested Date:	<u>Apr. 03, 2012</u>		

CHANNEL NUMBER	CHANNEL FREQUENCY (MHz)	6dB DOWN BW (MHz)	Minimum Limit (MHz)
1	2412	8.88	0.5
7	2442	8.68	0.5
11	2462	3.69	0.5

CH1:

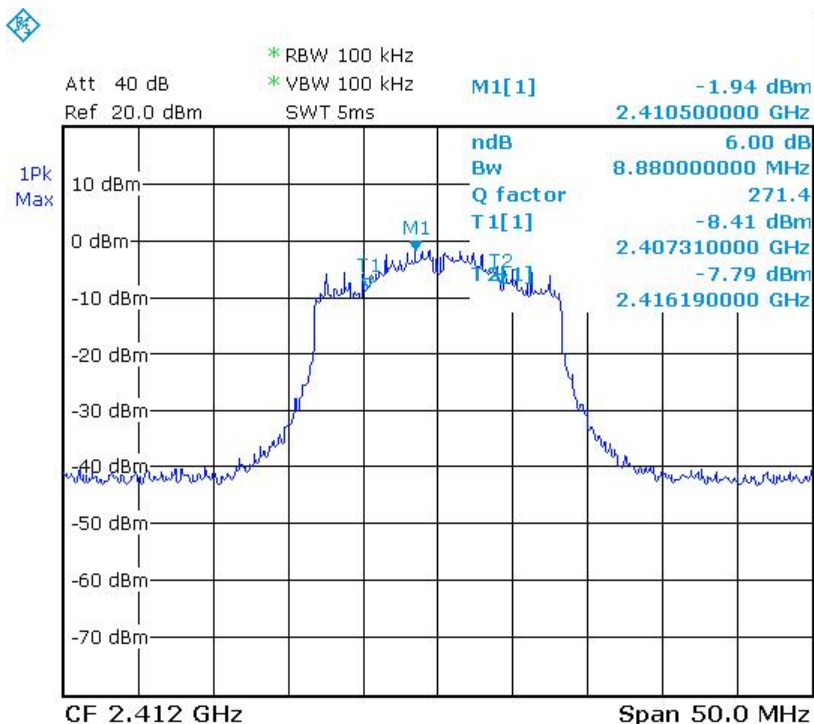



CH 7:

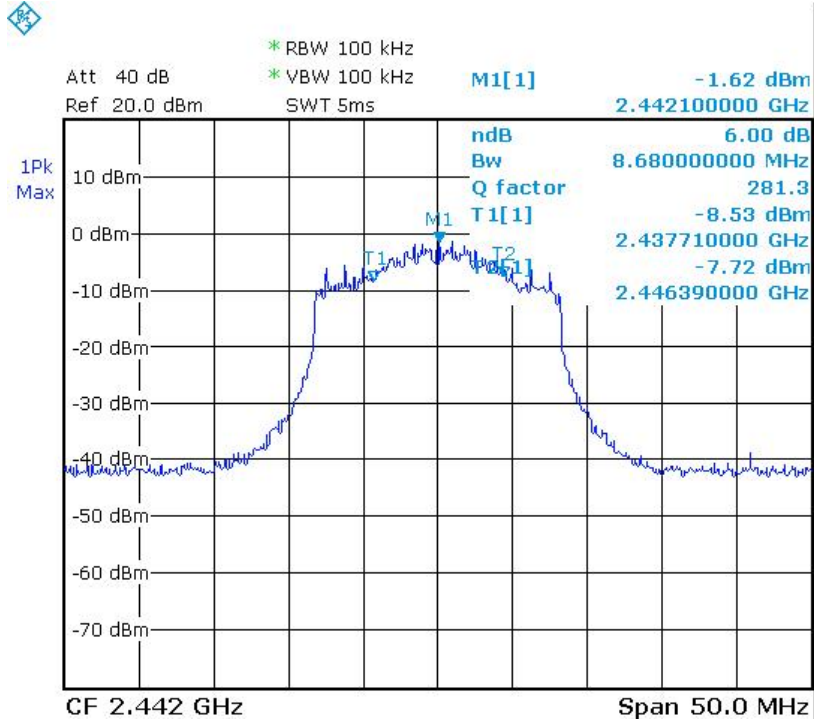

CH 11:

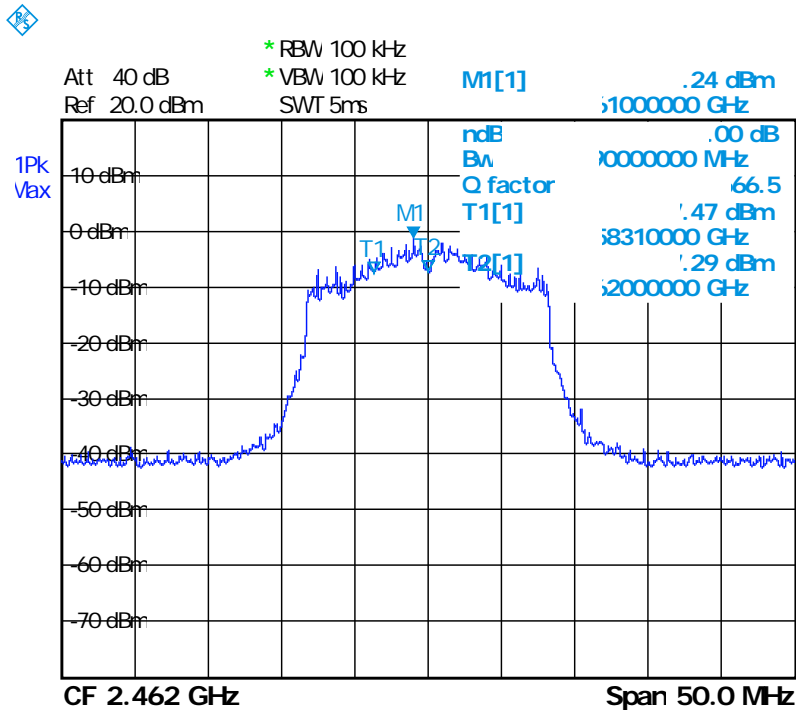



Spectrum Research & Testing Lab., Inc.
 No.167, Ln. 780, Shan-Tong Rd., Ling 8, Shan-Tong Li, Chung-Li City, Taoyuan County 320, Taiwan (R.O.C.)

TEST REPORT

Reference No.: A12030215
 Report No.: FCCA12030215
 FCC ID: JY8DW06
 Page: 49 of 82
 Date: Apr. 24, 2012

Temperature:	<u>22°C</u>	Humidity:	<u>51%RH</u>
Spectrum Detector:	<u>PK.</u>	Tested Mode:	<u>802.11n</u>
Tested By:	<u>Jeff Lo</u>	Modulation Type:	<u>64QAM</u>
Tested Date:	<u>Apr. 03, 2012</u>		

CHANNEL NUMBER	CHANNEL FREQUENCY (MHz)	6dB DOWN BW (MHz)	Minimum Limit (MHz)
5	2422	8.58	0.5
8	2437	3.69	0.5
11	2452	3.89	0.5

CH5:

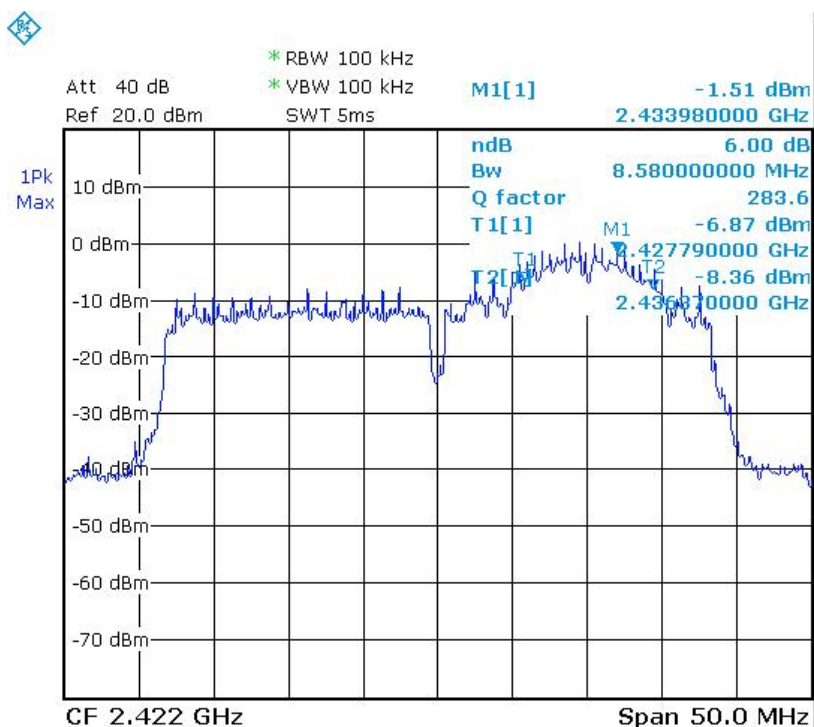



CH8:

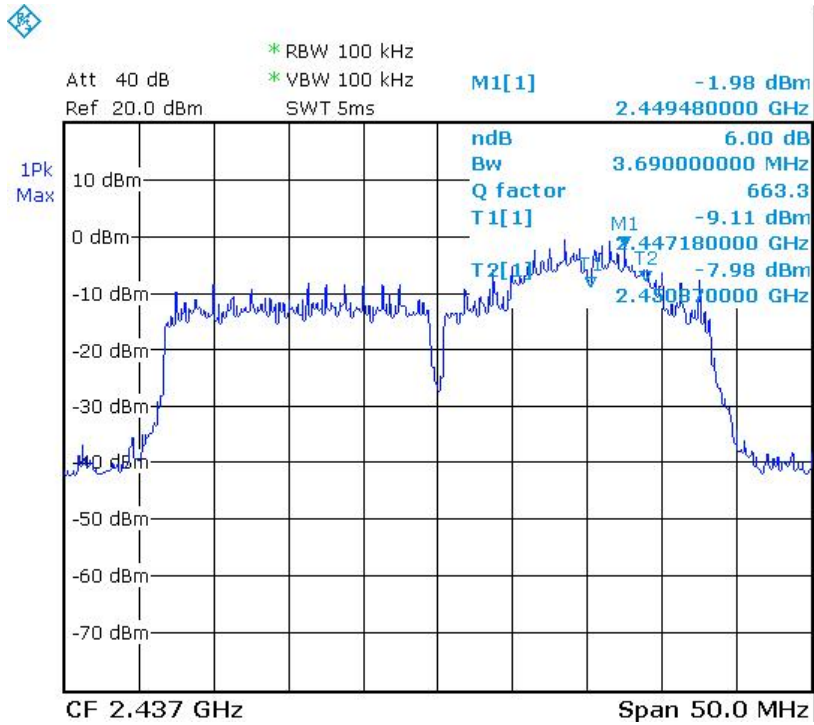

CH11:

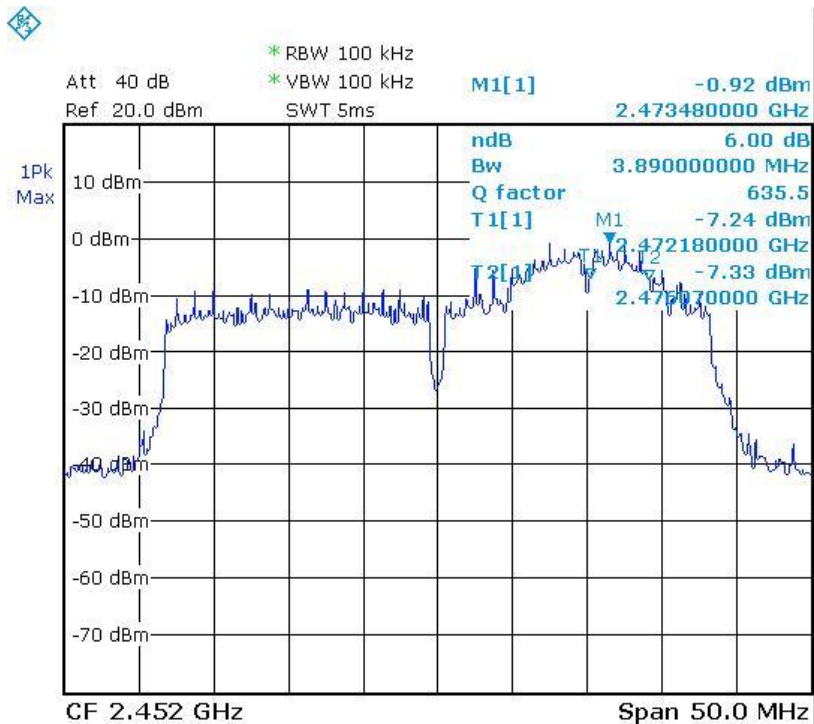



4.4 PEAK POWER TEST

4.4.1 LIMIT

FCC Part15, Subpart C Section 15.247(b).

Frequency Range (MHz)	The maximum (peak) conducted output power Limit(w)				
	Quantity of Hopping Channel	50	25	15	75
902-928		1(30dBm)	0.125(21dBm)	NA	NA
2400-2483.5		NA	NA	0.125(21dBm)	1(30dBm)
5725-5850		NA	NA	NA	1(30dBm)

4.4.2 TEST EQUIPMENT

The following test equipment was used during the test:

EQUIPMENT/ FACILITIES	SPECIFICATIONS	MANUFACTURER	MODEL#/ SERIAL#	DUE DATE OF CAL. & CAL. CENTER
SPECTRUM	9kHz-40GHz	ROHDE & SCHWARZ	FSP40/ 100093	Dec. 2012 ETC
EMI Test Receiver	9kHz-6GHz	ROHDE & SCHWARZ	ESL/ 100176	Mar. 2012 R&S

NOTE: The calibration interval of the above test equipment is one year and the calibrations are traceable to NML/ROC and NIST/USA.

4.4.3 TEST SET-UP

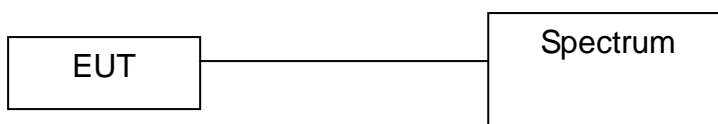

The EUT was connected to a spectrum through a 50Ω RF cable.

4.4.4 TEST PROCEDURE

The EUT was operating in continuous transmission mode or could control its channel. Printed out the test result from the spectrum by hard copy function.

4.4.5 EUT OPERATING CONDITION

1. Set the EUT under continuous transmission condition.
2. The EUT was set to the highest available power level.



4.4.6 TEST RESULT

Temperature:	22°C	Humidity:	51%RH
Spectrum Detector:	PK.	Tested Mode:	802.11b
Tested By:	Jeff Lo	Modulation Type:	QPSK
Tested Date:	Feb. 29, 2012		

Channel Number	Channel Frequency (MHz)	Peak Conducted Power (dBm)	Output Power (dBm)	Power Limit (dBm)
1	2412	7.20	15.46	30
7	2442	6.06	14.63	30
11	2462	6.46	14.96	30

CH1 :

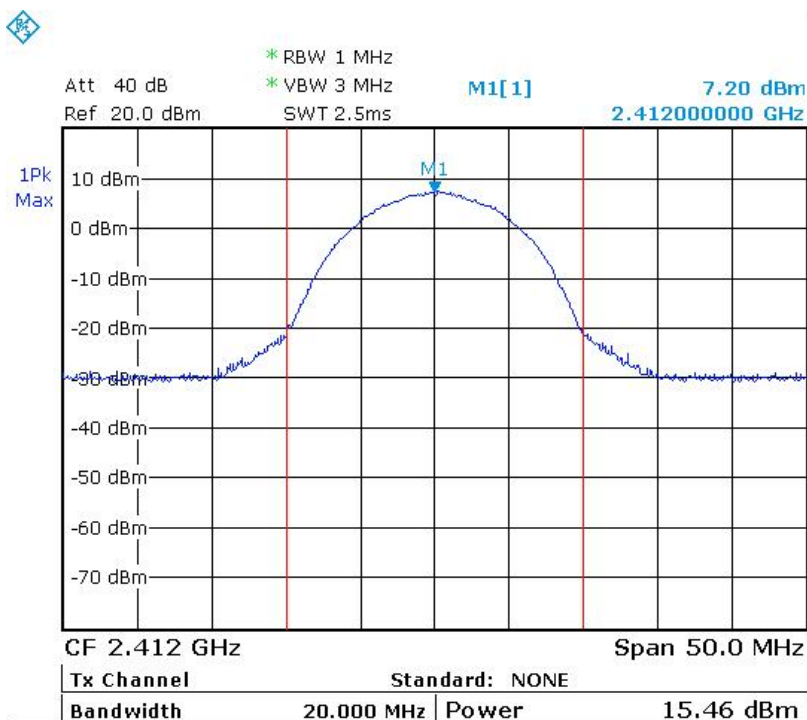



CH7 :



CH11 :

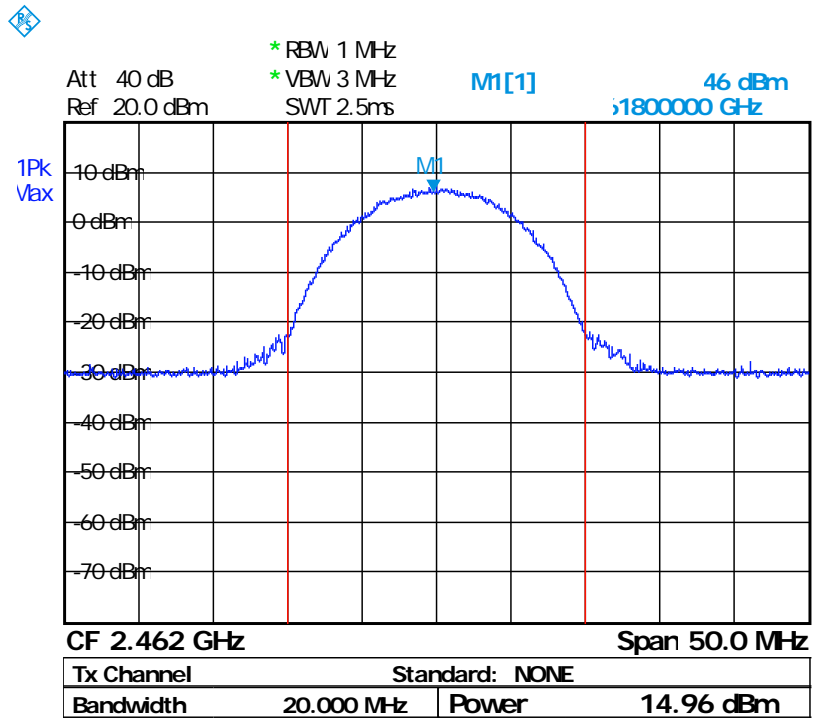



Spectrum Research & Testing Lab., Inc.
 No.167, Ln. 780, Shan-Tong Rd., Ling 8, Shan-Tong Li, Chung-Li City, Taoyuan County 320, Taiwan (R.O.C.)

TEST REPORT

Reference No.: A12030215
 Report No.: FCCA12030215
 FCC ID: JY8DW06
 Page: 54 of 82
 Date: Apr. 24, 2012

Temperature:	<u>22°C</u>	Humidity:	<u>51%RH</u>
Spectrum Detector:	<u>PK.</u>	Tested Mode:	<u>802.11g</u>
Tested By:	<u>Jeff Lo</u>	Modulation Type:	<u>64QAM</u>
Tested Date:	<u>Apr. 03, 2012</u>		

Channel Number	Channel Frequency (MHz)	Peak Conducted Power (dBm)	Output Power (dBm)	Power Limit (dBm)
1	2412	5.92	15.20	30
7	2442	5.14	14.62	30
11	2462	5.38	15.18	30

CH1 :

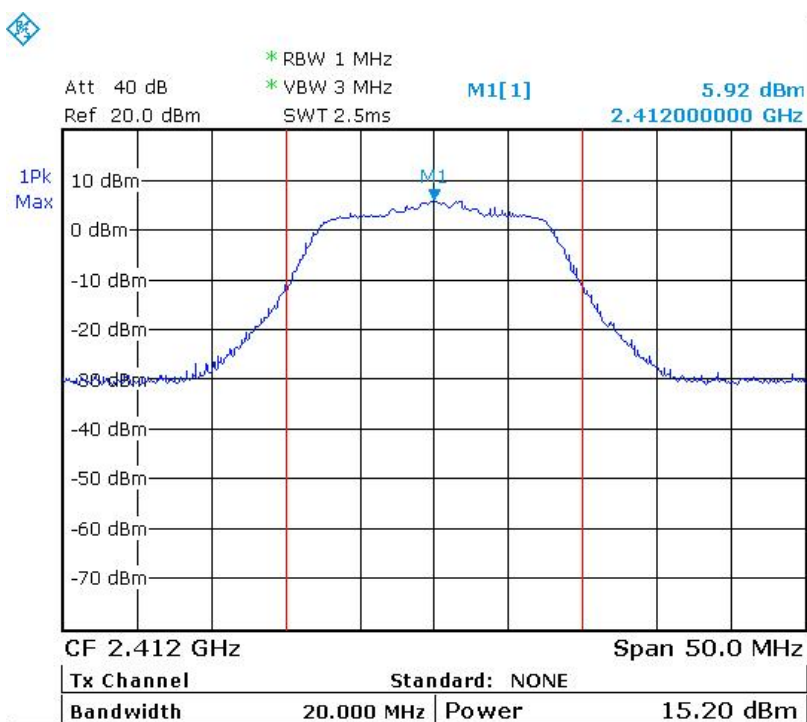



CH7 :

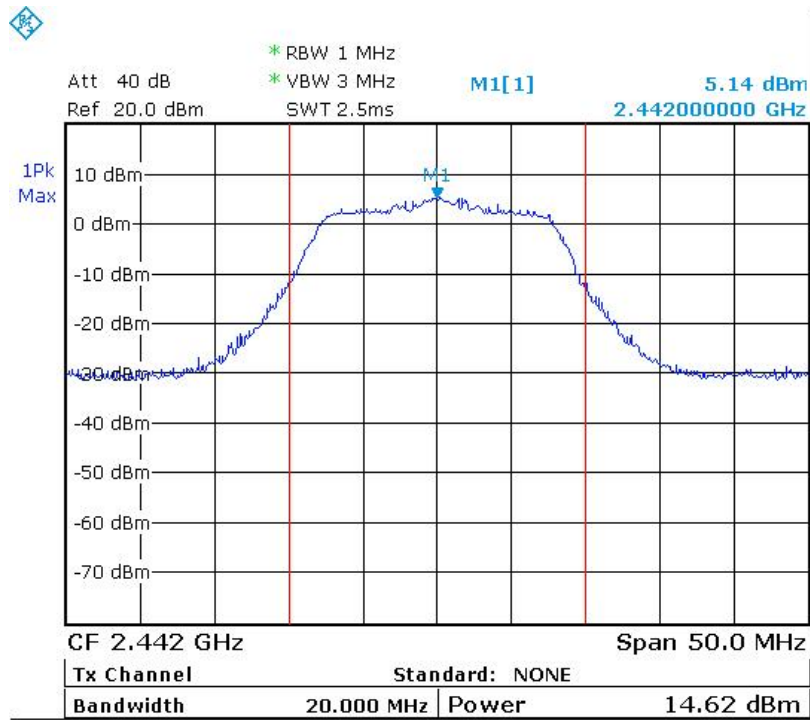

CH11 :

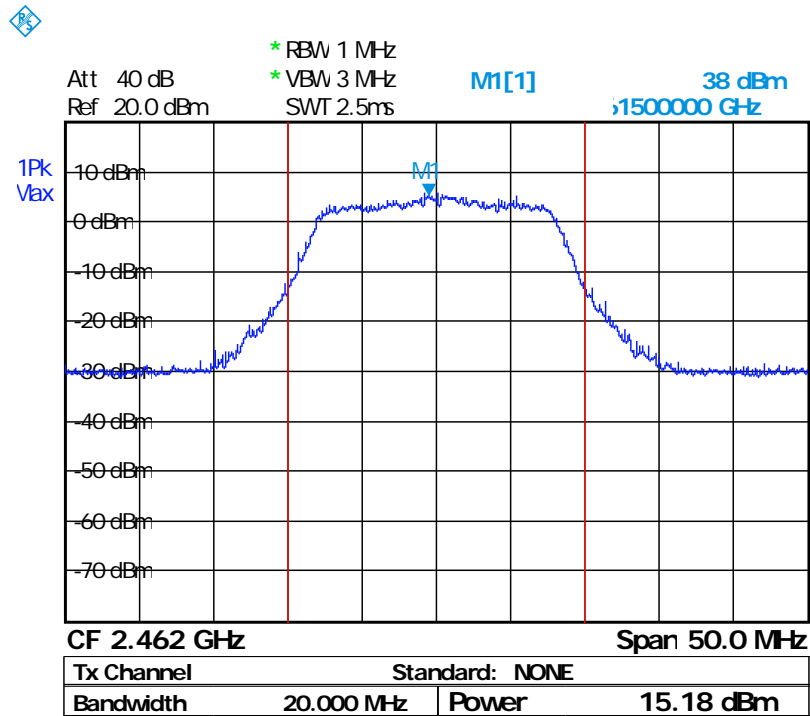



Spectrum Research & Testing Lab., Inc.
 No.167, Ln. 780, Shan-Tong Rd., Ling 8, Shan-Tong Li, Chung-Li City, Taoyuan County 320, Taiwan (R.O.C.)

TEST REPORT

Reference No.: A12030215
 Report No.: FCCA12030215
 FCC ID: JY8DW06
 Page: 56 of 82
 Date: Apr. 24, 2012

Temperature:	<u>22°C</u>	Humidity:	<u>51%RH</u>
Spectrum Detector:	<u>PK.</u>	Tested Mode:	<u>802.11n</u>
Tested By:	<u>Jeff Lo</u>	Modulation Type:	<u>64QAM</u>
Tested Date:	<u>Apr. 03, 2012</u>		

Channel Number	Channel Frequency (MHz)	Peak Conducted Power (dBm)	Output Power (dBm)	Power Limit (dBm)
5	2422	5.12	16.23	30
8	2437	4.49	15.52	30
11	2452	4.56	15.66	30

CH5 :

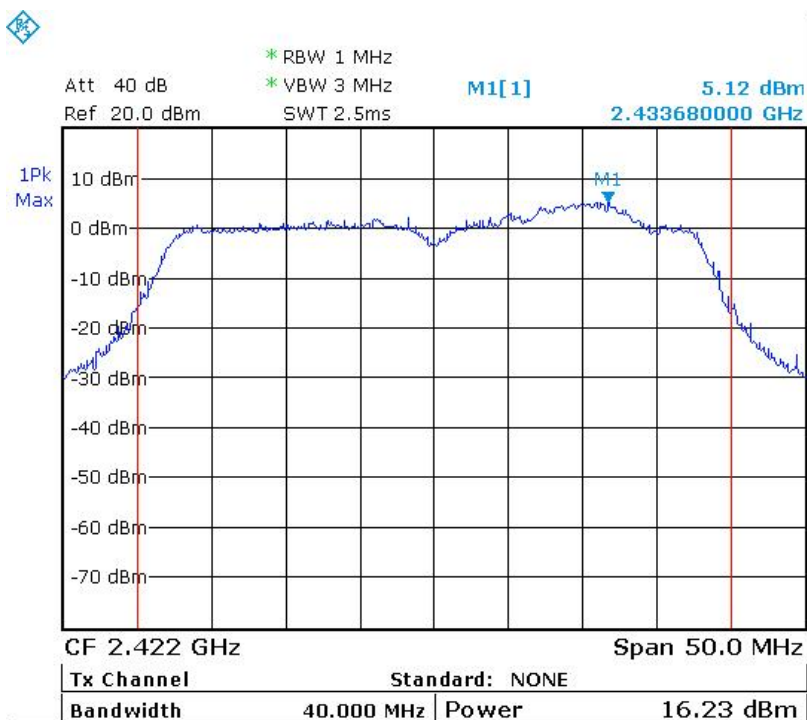



CH8 :

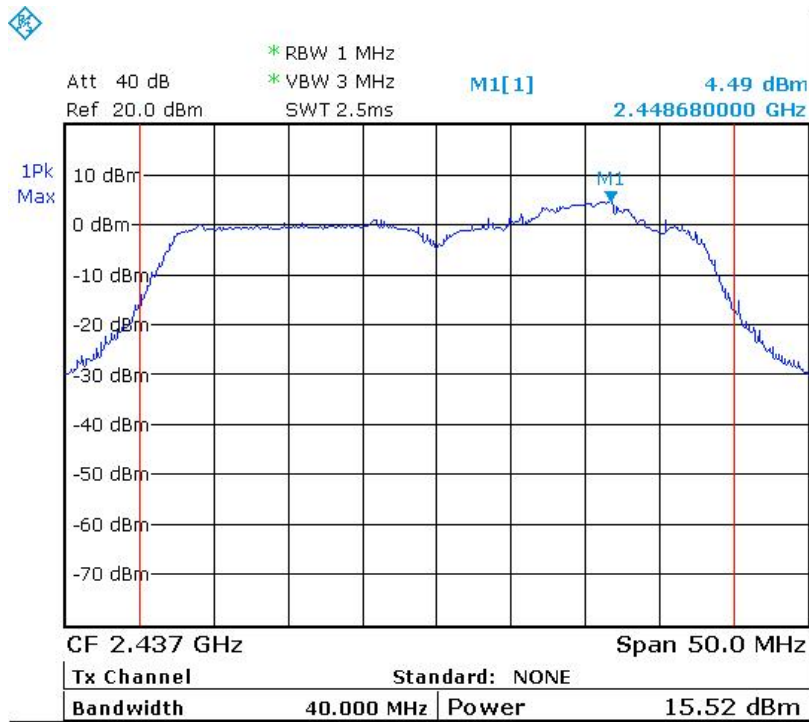

CH11 :

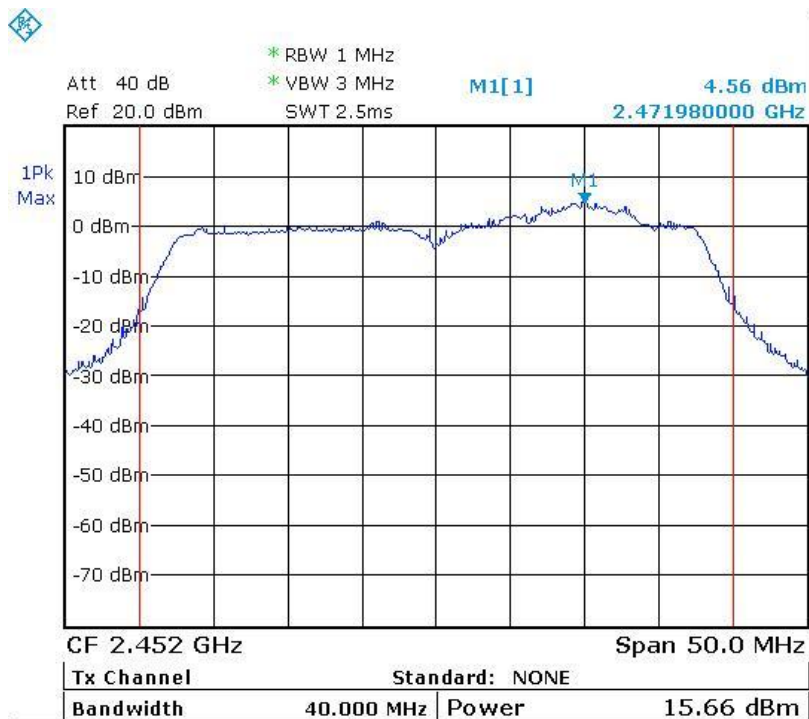



4.5 BAND EDGE TEST

4.5.1 LIMIT

FCC Part15, Subpart C Section 15.247. In any 100 kHz bandwidth outside the frequency band in which the spread spectrum intentional radiator is operating, the radio frequency power that is produced by the intentional radiator shall be at least 20 dB below that in the 100 kHz bandwidth within the band that contains the highest level of the desired power, based on either an RF conducted or a radiated measurement.

Attenuation below the general limits specified in Section 15.209(a) is not required. In addition, radiated emissions which fall in the restricted bands, as defined in Section 15.205(a), must also comply with the radiated emission limits specified in Section 15.209(a) (see Section 15.205(c)).

OPERATING FREQUENCY RANGE (MHz)	SPURIOUS EMISSION FREQUENCY (MHz)	LIMIT	
		Peak power ration to emission(dBc)	Emission level(dBuV/m)
902 - 928	<902	>20	NA
	>928	>20	NA
	960-1240	NA	54
2400 - 2483.5	<2400	>20	NA
	>2483.5-2500	NA	54
5725 - 5850	<5350-5460	NA	54
	<5725	>20	NA
	>5850	>20	NA



**Spectrum Research
& Testing Lab., Inc.**
No.167, Ln. 780, Shan-Tong
Rd., Ling 8, Shan-Tong Li,
Chung-Li City, Taoyuan County
320, Taiwan (R.O.C.)

TEST REPORT

Reference No.: A12030215
Report No.: FCCA12030215
FCC ID: JY8DW06
Page: 59 of 82
Date: Apr. 24, 2012

4.5.2 TEST EQUIPMENT

The following test equipment was used during the test:

EQUIPMENT/ FACILITIES	SPECIFICATIONS	MANUFACTURER	MODEL#/ SERIAL#	DUE DATE OF CAL. & CAL. CENTER
SPECTRUM	9kHz-40GHz	ROHDE & SCHWARZ	FSP40/ 100093	Dec. 2012 ETC
EMI Test Receiver	9kHz-6GHz	ROHDE & SCHWARZ	ESL/ 100176	Mar. 2013 R&S
SPECTRUM	9KHz-26.5GHz	HP	8953E/ 3710A03220	Nov. 2012 ETC
PRE-AMPLIFIER	1GHz-26.5GHz Gain:30dB	HP	8449B/ 3008A01019	Nov. 2012 ETC
HORN ANTENNA	1GHz to 18GHz	EMCO	3115/ 6881	Nov. 2012 ETC
K-TYPE CABLE	1M	HUBER SUHNER	SF102-40/2*11 / 28934/2	May. 2012 ETC
RF CABLE	1.5M	JYEBAO	A30A30-L 142 / EQF-0035	Dec. 2012 ETC
RF CABLE	3.5M	JYEBAO	A30A30-L 142 (G3.5M)/ EQF-0036(002)	Dec. 2012 ETC

NOTE: The calibration interval of the above test equipment is one year and the calibrations are traceable to NML/ROC and NIST/USA.



4.5.3 TEST SET-UP

FOR RF CONDUCTED TEST (dBc)

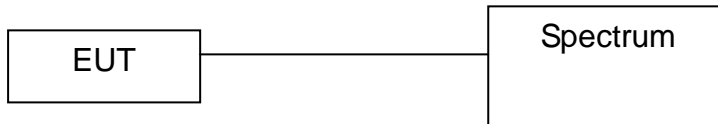

The EUT was connected to a spectrum through a 50Ω RF cable.

FOR RADIATED EMISSION TEST

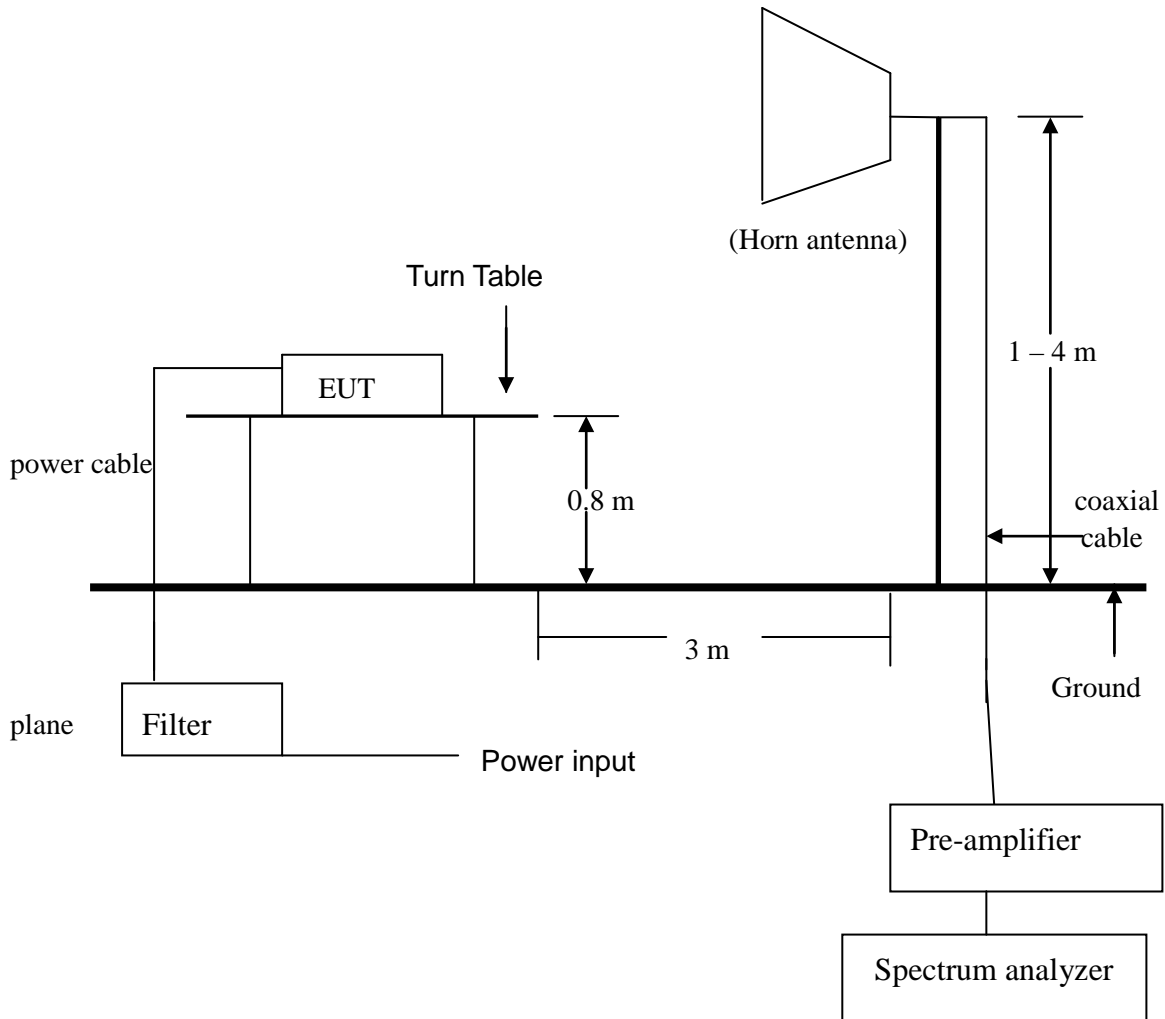

NOTE :

1. The EUT system was put on a wooden table with 0.8m heights above a ground plane.
2. For the actual test configuration, please refer to the photos of testing.



4.5.4 TEST PROCEDURE

1. The EUT was operating in continuous transmission mode or could be controlled its channel. Printed out the test result from the spectrum by hard copy function.
2. The EUT was tested according to the requirement of ANSI C63.4 and CISPR 22. The measurements were made at an open area test site with 3 meter measurement distance under 1 GHz and with 3m distance above 1GHz. The frequency spectrum measured started from 30 MHz. Under 1 GHz. All readings were quasi-peak values with 120 kHz resolution bandwidth of the test receiver. Above 1 GHz, the measurements were made at an open area test site with 3 meter measurement distance and all readings were peak and average values with 1 MHz resolution bandwidth of the test receiver. The EUT system was operated in all typical methods by users. The cables connected to EUT and support units were moved to find the maximum emission levels for each frequency.

4.5.5 EUT OPERATING CONDITION

1. Set the EUT under continuous transmission condition.
2. The EUT was set to the highest available power level.



4.5.6 TEST RESULT

Temperature:	22°C	Humidity:	51%RH
Spectrum Detector:	PK. or AV.	Tested Mode:	802.11b
Tested By:	Jeff Lo	Modulation Type:	QPSK
Tested Date:	Apr. 03, 2012		

1. Conducted test

Frequency (MHz)	PEAK POWER OUTPUT (dBm)	Emission read Value (dBm)	Result of Band edge (dBc)	Band edge LIMIT (dBc)
<2400	-0.98	-39.21	40.19	>20dBc
>2483.5	-0.62	-37.15	37.77	>20dBc

Below 2400MHz (CH1):

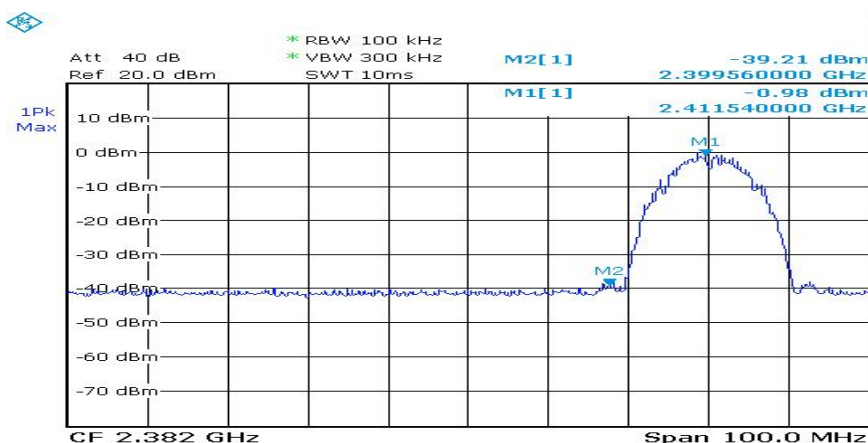

Above 2483.5 MHz (CH11):

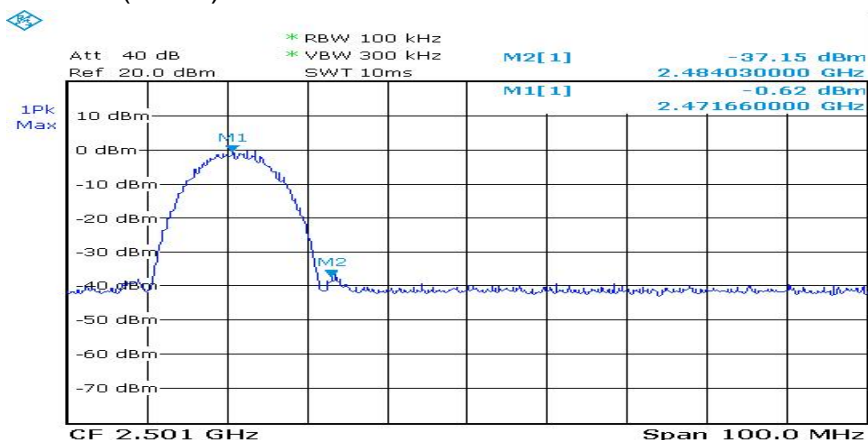



TEST REPORT

2.Radiated emission test:
 Below 2400MHz (CH1)

Frequency (MHz)	Correct Factor (dB)	Ant. Fac. (dB)	Ant. Pol. (H/V)	Reading (dBuV)		Emission (dBuV/m)		Limit Line (dBuV/m)		Over Limit (dBuV/m)	
				PK	AV	PK	AV	PK	AV	PK	AV
2412.00	-33.88	28.11	H	95.3	84.3	89.5	78.6	114.0	94.0	-24.5	-15.4
2412.00	-33.88	28.11	V	103.8	91.2	98.0	85.4	114.0	94.0	-16.0	-8.6
2400.00	-33.88	28.08	H	67.1	56.4	61.3	50.6	74.0	54.0	-12.7	-3.4
2400.00	-33.88	28.08	V	66.8	56.6	60.9	50.7	74.0	54.0	-13.1	-3.3
2390.40	-33.89	28.06	H	54.4	42.9	48.6	37.1	74.0	54.0	-25.4	-16.9
2390.00	-33.89	28.06	V	50.8	39.9	44.9	34.0	74.0	54.0	-29.1	-20.0

Horizontal:

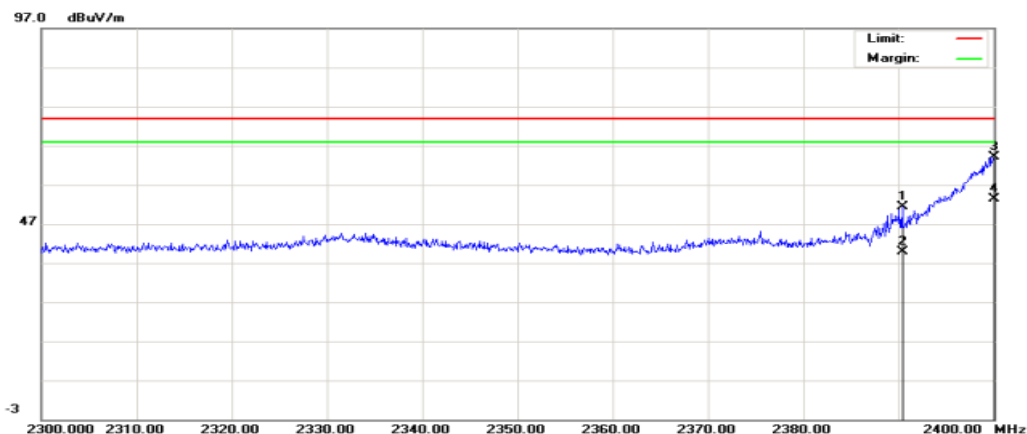

Vertical:

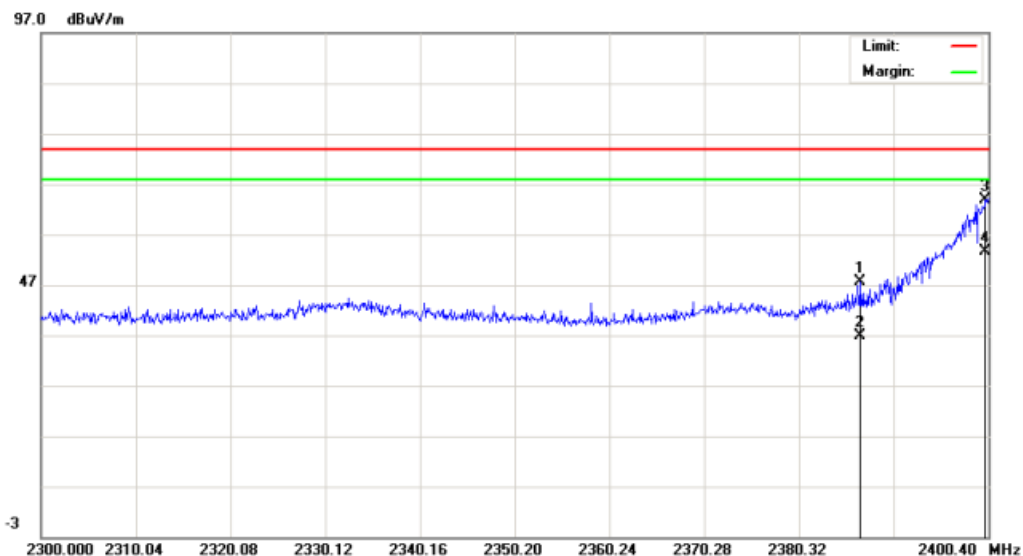



TEST REPORT

Above 2483.5 MHz (CH11)

Frequency (MHz)	Correct Factor (dB)	Ant. Fac. (dB)	Ant. Pol. (H/V)	Reading (dBuV)		Emission (dBuV/m)		Limit Line (dBuV/m)		Over Limit (dBuV/m)	
				PK	AV	PK	AV	PK	AV	PK	AV
2472.00	-33.87	28.24	H	88.4	77.7	82.7	72.1	114.0	94.0	-31.3	-21.9
2472.00	-33.87	28.24	V	94.1	83.1	88.4	77.5	114.0	94.0	-25.6	-16.5
2485.23	-33.86	28.27	H	66.0	54.3	60.4	48.7	74.0	54.0	-13.6	-5.3
2485.46	-33.86	28.27	V	65.5	53.9	59.9	48.3	74.0	54.0	-14.1	-5.7
2497.19	-33.86	28.29	H	50.3	39.9	44.8	34.4	74.0	54.0	-29.2	-19.6
2499.84	-33.86	28.30	V	49.5	38.7	43.9	33.2	74.0	54.0	-30.1	-20.8

Horizontal:

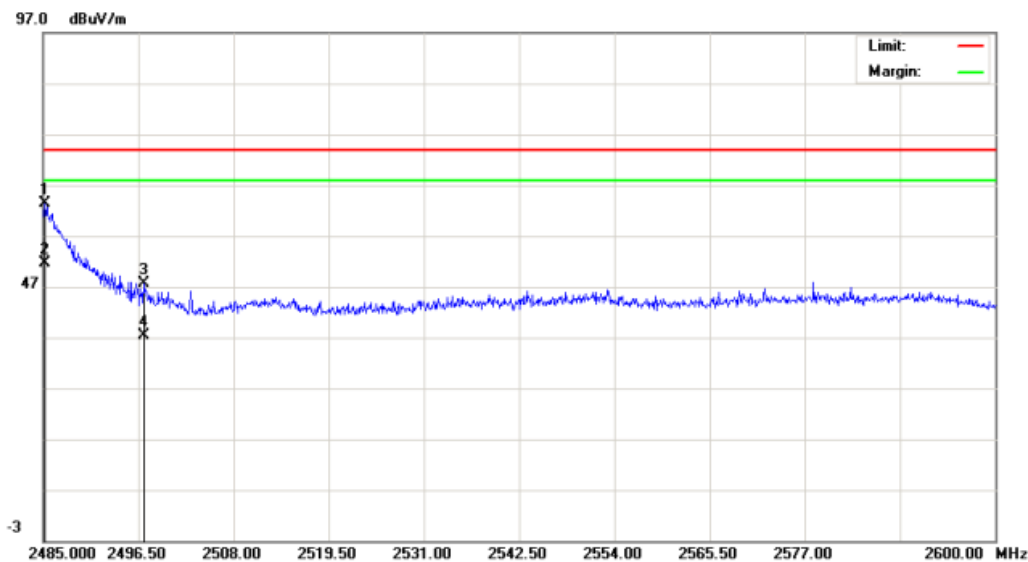

Vertical:

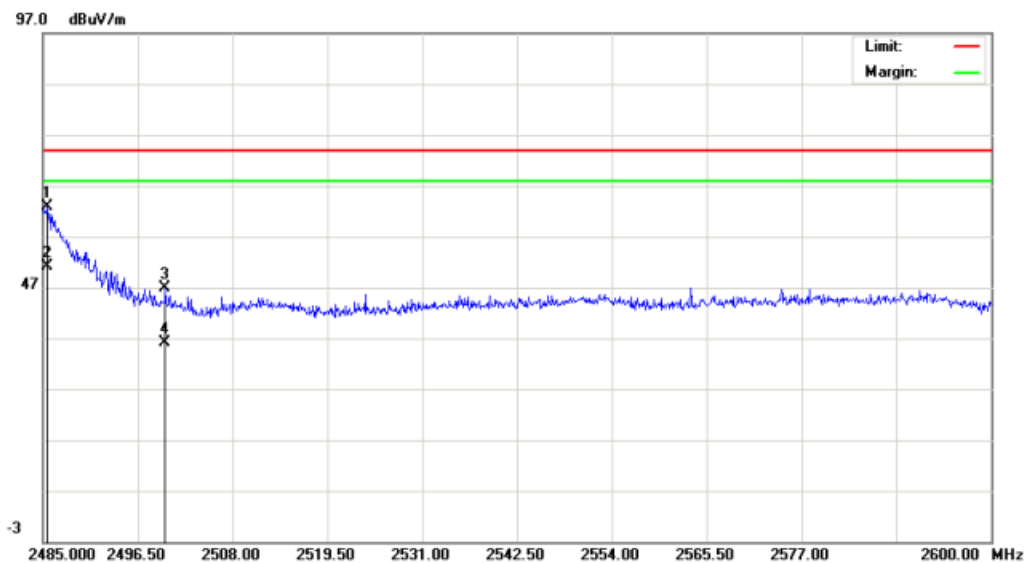



Spectrum Research & Testing Lab., Inc.
 No.167, Ln. 780, Shan-Tong Rd., Ling 8, Shan-Tong Li, Chung-Li City, Taoyuan County 320, Taiwan (R.O.C.)

TEST REPORT

Reference No.: A12030215
 Report No.: FCCA12030215
 FCC ID: JY8DW06
 Page: 65 of 82
 Date: Apr. 24, 2012

Temperature:	22°C	Humidity:	51%RH
Spectrum Detector:	PK. or AV.	Tested Mode:	802.11g
Tested By:	Jeff Lo	Modulation Type:	64QAM
Tested Date:	Apr. 03, 2012		

1. Conducted test

Frequency (MHz)	PEAK POWER OUTPUT (dBm)	Emission read Value(dBm)	Result of Band edge (dBc)	Band edge LIMIT (dBc)
<2400	-0.27	-38.88	39.15	>20dBc
>2483.5	0.08	-40.54	40.62	>20dBc

Below 2400MHz (CH1):

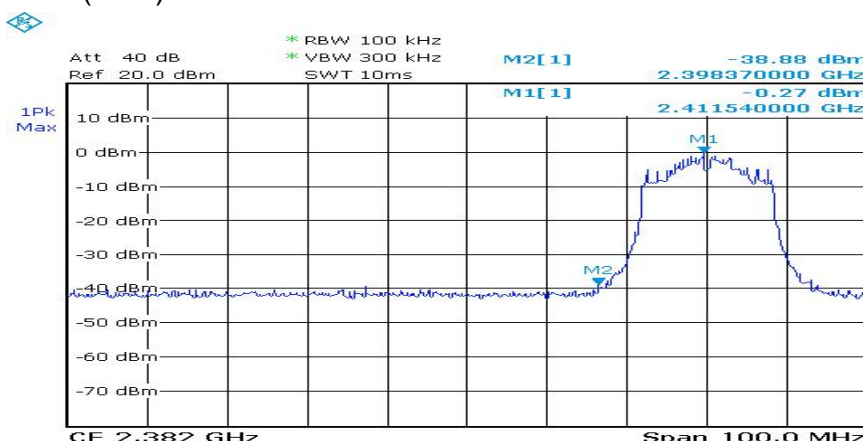

Above 2483.5 MHz (CH11):





TEST REPORT

2. Radiated emission test Below 2400MHz (CH1)

Frequency (MHz)	Correct Factor (dB)	Ant. Fac. (dB)	Ant. Pol. (H/V)	Reading (dBuV)		Emission (dBuV/m)		Limit Line (dBuV/m)		Over Limit (dBuV/m)	
				PK	AV	PK	AV	PK	AV	PK	AV
2412.00	-33.88	28.11	H	87.6	76.6	81.8	70.8	114.0	94.0	-32.2	-23.2
2412.00	-33.88	28.11	V	95.7	84.3	89.9	78.5	114.0	94.0	-24.1	-15.5
2400.00	-33.88	28.08	H	70.6	55.7	64.8	49.9	74.0	54.0	-9.2	-4.1
2400.00	-33.88	28.08	V	71.4	56.1	65.6	50.3	74.0	54.0	-8.4	-3.7
2384.10	-33.89	28.04	H	50.9	39.9	45.0	34.0	74.0	54.0	-29.0	-20.0
2386.40	-33.89	28.05	V	51.7	41.3	45.9	35.5	74.0	54.0	-28.1	-18.5

Horizontal:

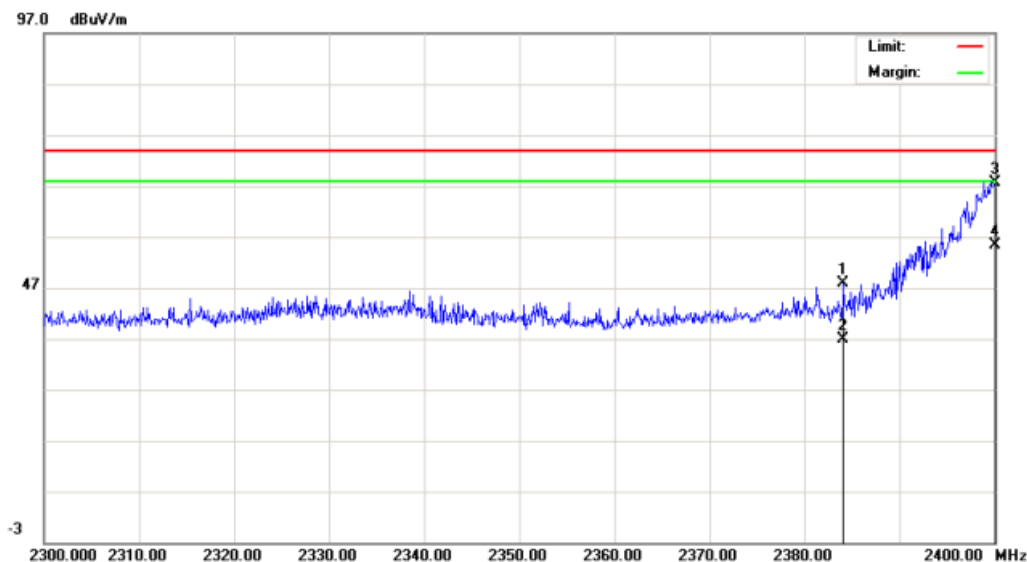

Vertical:

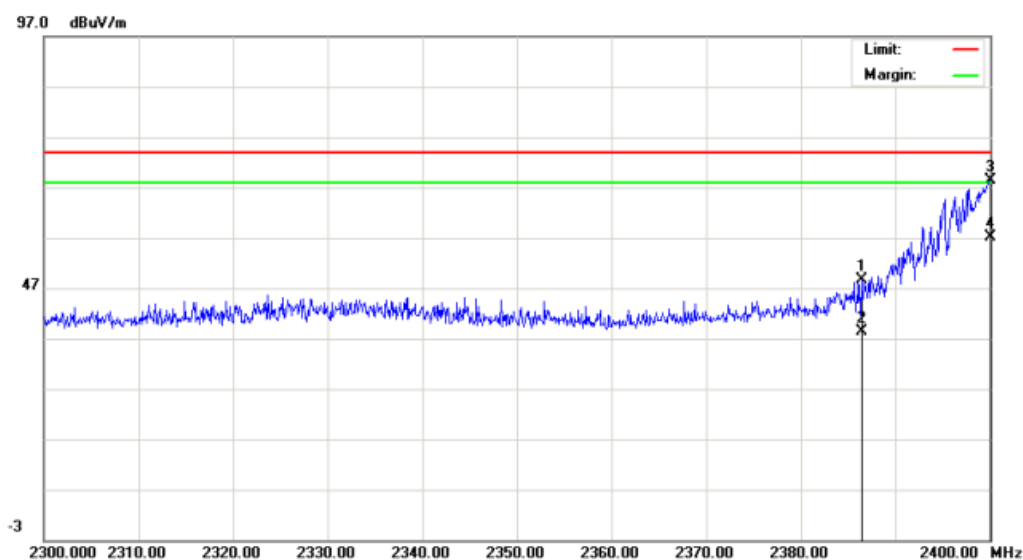



TEST REPORT

Above 2483.5 MHz (CH11)

Frequency (MHz)	Correct Factor (dB)	Ant. Fac. (dB)	Ant. Pol. (H/V)	Reading (dBuV)		Emission (dBuV/m)		Limit Line (dBuV/m)		Over Limit (dBuV/m)	
				PK	AV	PK	AV	PK	AV	PK	AV
2472.00	-33.87	28.24	H	94.0	83.9	88.4	78.3	114.0	94.0	-25.6	-15.7
2472.00	-33.87	28.24	V	96.0	85.4	90.3	79.8	114.0	94.0	-23.7	-14.2
2485.92	-33.86	28.27	H	75.1	56.5	69.5	50.9	74.0	54.0	-4.5	-3.1
2485.46	-33.86	28.27	V	74.7	55.5	69.1	49.9	74.0	54.0	-4.9	-4.1
2495.81	-33.86	28.29	H	57.0	46.4	51.4	40.9	74.0	54.0	-22.6	-13.1
2495.35	-33.86	28.29	V	58.7	47.3	53.1	41.7	74.0	54.0	-20.9	-12.3

Horizontal:

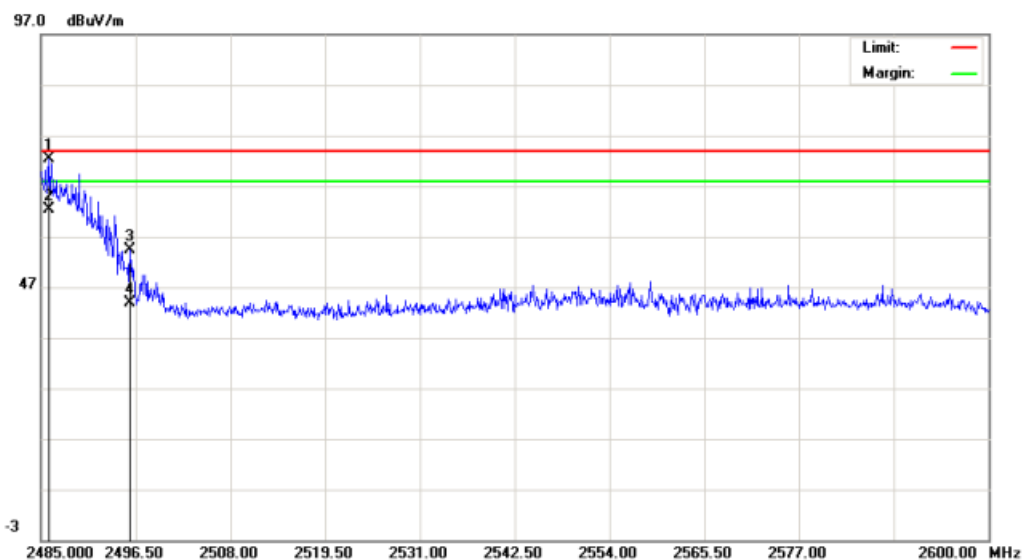

Vertical:

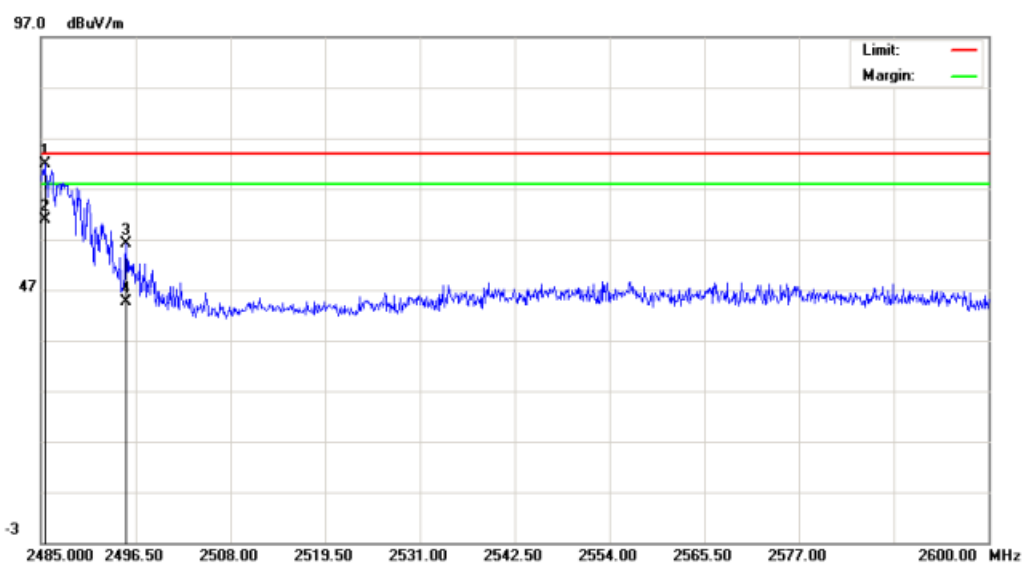



Spectrum Research & Testing Lab., Inc.
 No.167, Ln. 780, Shan-Tong Rd., Ling 8, Shan-Tong Li, Chung-Li City, Taoyuan County 320, Taiwan (R.O.C.)

TEST REPORT

Reference No.: A12030215
 Report No.: FCCA12030215
 FCC ID: JY8DW06
 Page: 68 of 82
 Date: Apr. 24, 2012

Temperature:	<u>22°C</u>	Humidity:	<u>51%RH</u>
Spectrum Detector:	<u>PK. or AV.</u>	Tested Mode:	<u>802.11n</u>
Tested By:	<u>Jeff Lo</u>	Modulation Type:	<u>64QAM</u>
Tested Date:	<u>Apr. 03, 2012</u>		

1. Conducted test

Frequency (MHz)	PEAK POWER OUTPUT (dBm)	Emission read Value (dBm)	Result of Band edge (dBc)	Band edge LIMIT (dBc)
<2400	-2.27	-40.02	42.29	>20dBc
>2483.5	-1.74	-41.41	43.15	>20dBc

Below 2400MHz (CH5):

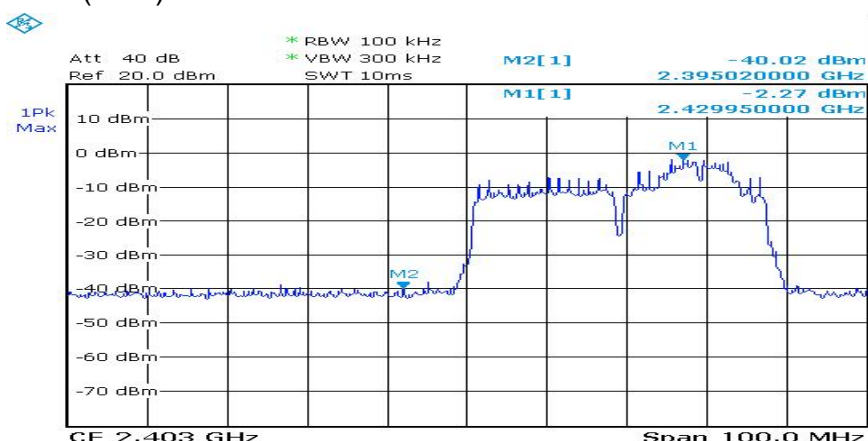

Above 2483.5 MHz (CH11):





2. Radiated emission test
 Below 2400MHz (CH5)

Frequency (MHz)	Correct Factor (dB)	Ant. Fac. (dB)	Ant. Pol. (H/V)	Reading (dBuV)		Emission (dBuV/m)		Limit Line (dBuV/m)		Over Limit (dBuV/m)	
				PK	AV	PK	AV	PK	AV	PK	AV
2422.00	-33.88	28.13	H	102.7	91.4	96.9	85.7	114.0	94.0	-17.1	-8.3
2422.00	-33.88	28.13	V	103.1	92.4	97.3	86.7	114.0	94.0	-16.7	-7.3
2398.70	-33.88	28.08	H	61.1	50.1	55.3	44.3	74.0	54.0	-18.7	-9.7
2399.50	-33.88	28.08	V	65.0	54.4	59.2	48.6	74.0	54.0	-14.8	-5.4
2386.70	-33.89	28.05	H	53.2	41.4	47.3	35.6	74.0	54.0	-26.7	-18.4
2386.10	-33.89	28.05	V	54.1	43.7	48.3	37.9	74.0	54.0	-25.7	-16.1

Horizontal:

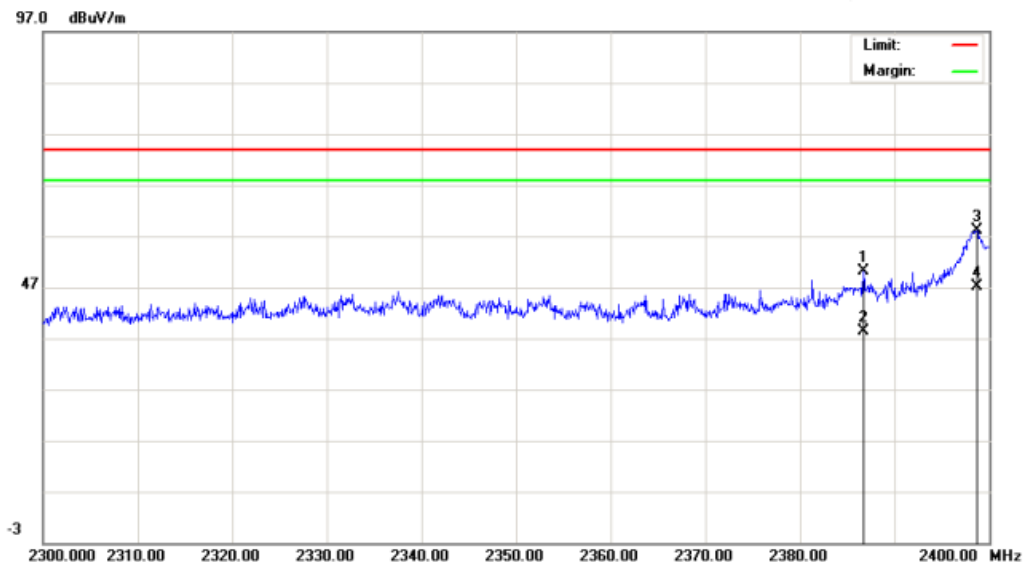

Vertical:

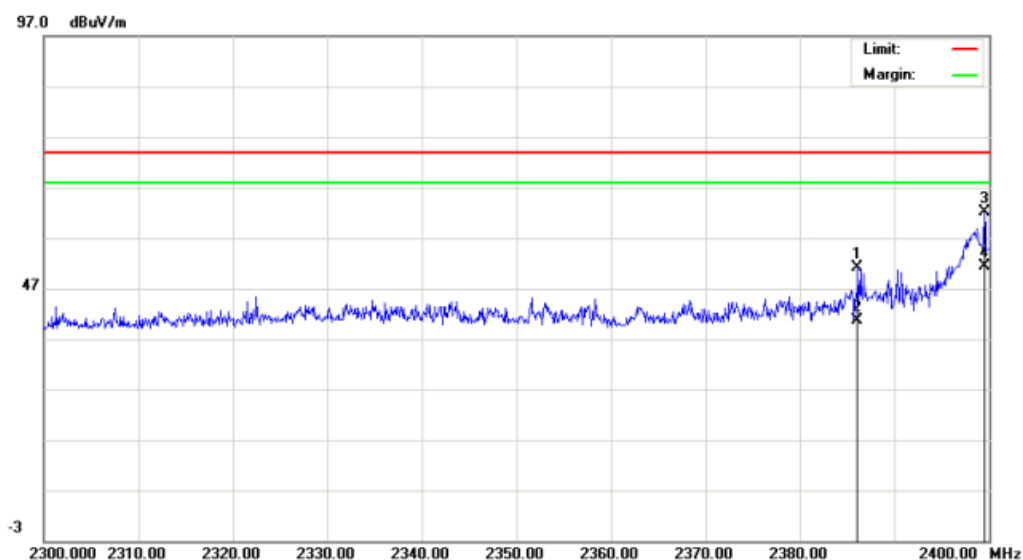



TEST REPORT

Above 2483.5 MHz (CH11)

Frequency (MHz)	Correct Factor (dB)	Ant. Fac. (dB)	Ant. Pol. (H/V)	Reading (dBuV)		Emission (dBuV/m)		Limit Line (dBuV/m)		Over Limit (dBuV/m)	
				PK	AV	PK	AV	PK	AV	PK	AV
2462.00	-33.87	28.22	H	100.2	89.9	94.5	84.2	114.0	94.0	-19.5	-9.8
2462.00	-33.87	28.22	V	100.6	90.1	94.9	84.4	114.0	94.0	-19.1	-9.6
2485.00	-33.86	28.27	H	68.1	56.4	62.5	50.8	74.0	54.0	-11.5	-3.2
2485.12	-33.86	28.27	V	69.9	56.4	64.3	50.8	74.0	54.0	-9.7	-3.2
2494.78	-33.86	28.29	H	65.6	54.7	60.0	49.1	74.0	54.0	-14.0	-4.9
2496.50	-33.86	28.29	V	60.5	49.1	54.9	43.5	74.0	54.0	-19.1	-10.5

Horizontal:

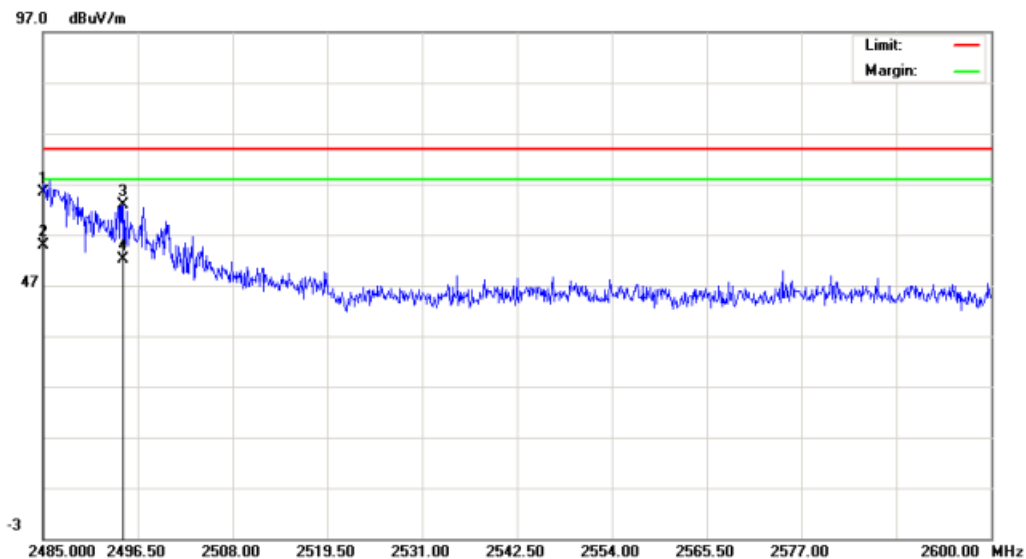

Vertical:

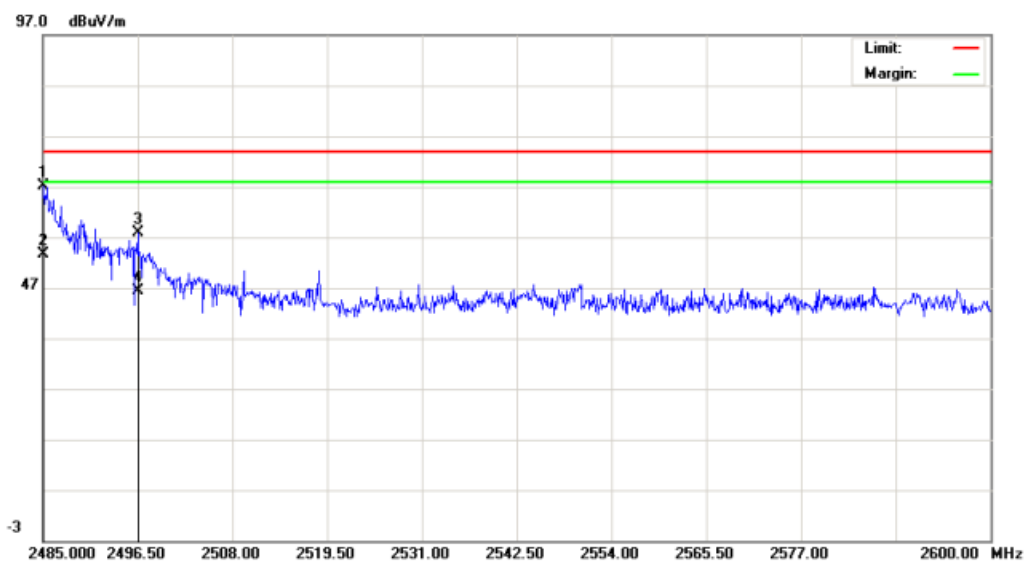



4.6 POWER DENSITY TEST

4.6.1 LIMIT

FCC Part15, Subpart C Section 15.247

FREQUENCY RANGE (MHz)	Limit(dBm/kHz)
902-928	8dBm/3kHz
2400-2483.5	
5725-5850	

4.6.2 TEST EQUIPMENT

The following test equipment was used during the radiated emission test:

EQUIPMENT/FACILITIES	SPECIFICATIONS	MANUFACTURER	MODEL#/SERIAL#	DUE DATE OF CAL. & CAL. CENTER
SPECTRUM	9kHz-40GHz	ROHDE & SCHWARZ	FSP40/100093	Dec. 2012 ETC
EMI Test Receiver	9kHz-6GHz	ROHDE & SCHWARZ	ESL/100176	Mar. 2012 R&S

NOTE: The calibration interval of the above test equipment is one year and the calibrations are traceable to NML/ROC and NIST/USA.

4.6.3 TEST SET-UP

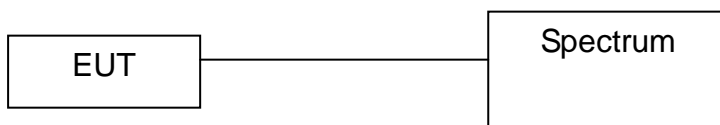

The EUT was connected to a spectrum through a 50Ω RF cable.

4.6.4 TEST PROCEDURE

The EUT was operating in transmitter mode and could be controlled its channel. Printed out the test result from the spectrum by hard copy function.

4.6.5 EUT OPERATING CONDITION

1. Set the EUT under continuous transmission condition.
2. The EUT was set to the highest available power level.



Spectrum Research & Testing Lab., Inc.
 No.167,Ln. 780, Shan-Tong Rd.,Ling 8, Shan-Tong Li, Chung-Li City, Taoyuan County 320, Taiwan (R.O.C.)

TEST REPORT

Reference No.: A12030215
 Report No.: FCCA12030215
 FCC ID: JY8DW06
 Page: 72 of 82
 Date: Apr. 24, 2012

4.6.6 TEST RESULT

Temperature:	22°C	Humidity:	51%RH
Spectrum Detector:	PK.	Tested Mode:	802.11b
Tested By:	Jeff Lo	Modulation Type:	QPSK
Tested Date:	Apr. 03, 2012		

CHANNEL NUMBER	CHANNEL FREQUENCY (MHz)	RF POWER LEVEL IN 3KHz BW (dBm/3kHz)	MAXIMUM LIMIT (dBm/3kHz)
1	2412	-13.92	8
7	2442	-15.01	8
11	2462	-18.69	8

CH 1:

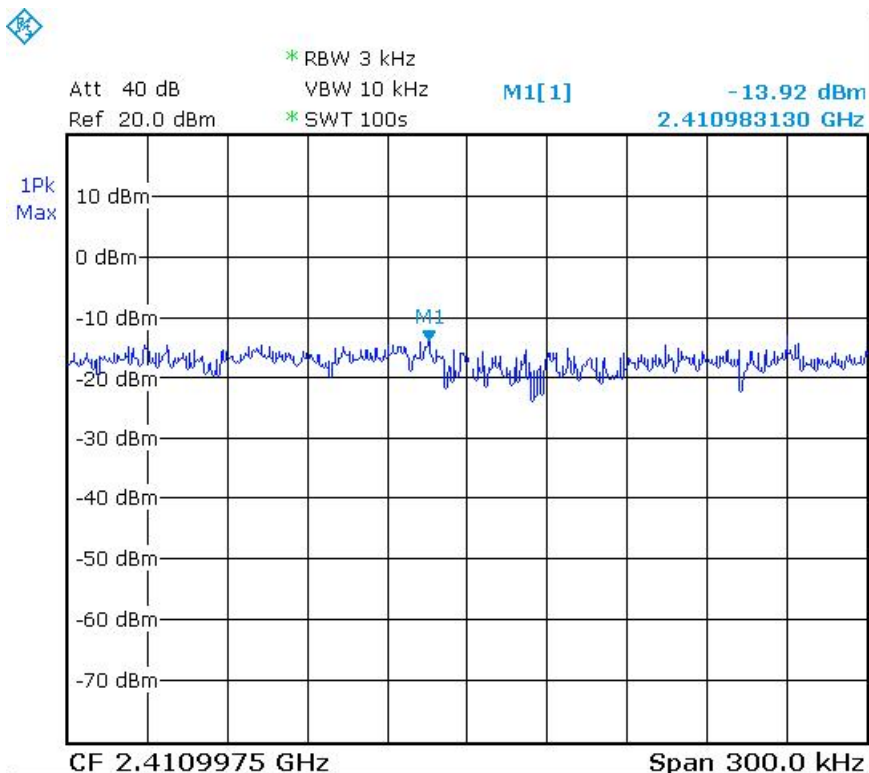



CH 7:

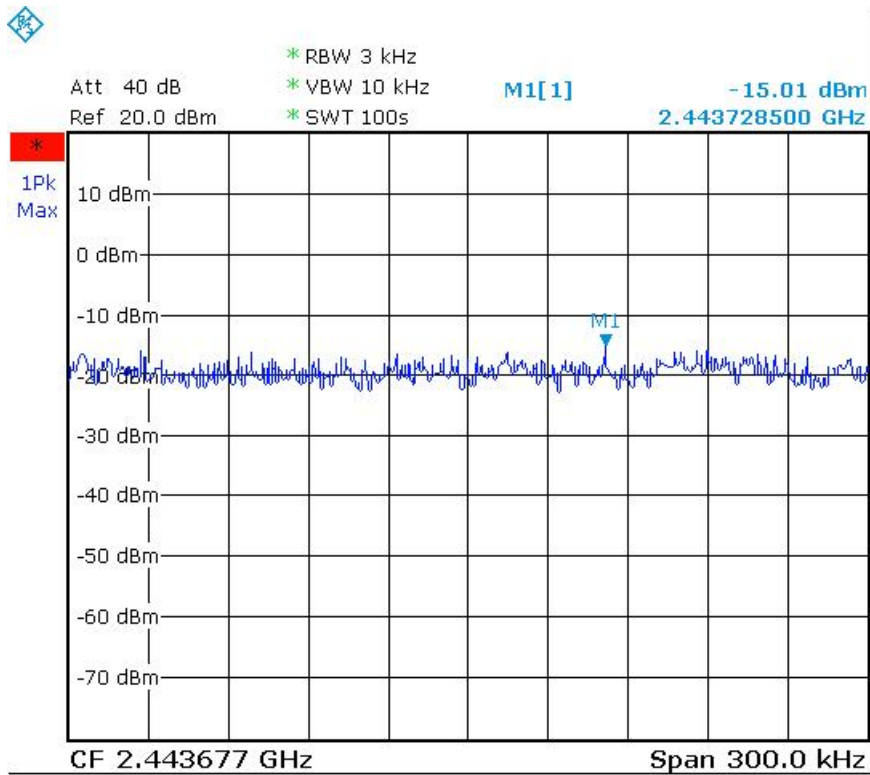

CH 11:

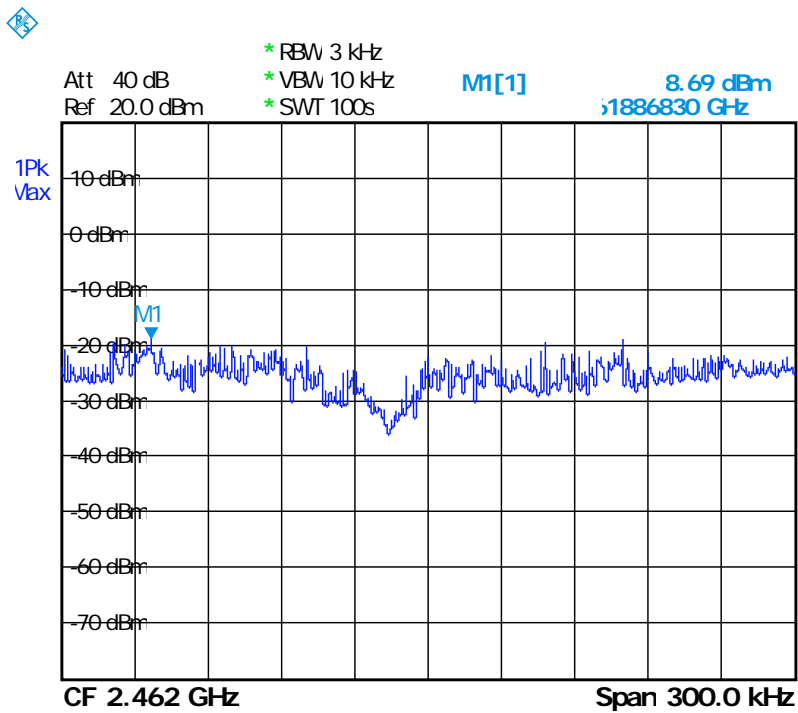



Spectrum Research & Testing Lab., Inc.
 No.167, Ln. 780, Shan-Tong Rd., Ling 8, Shan-Tong Li, Chung-Li City, Taoyuan County 320, Taiwan (R.O.C.)

TEST REPORT

Reference No.: A12030215
 Report No.: FCCA12030215
 FCC ID: JY8DW06
 Page: 74 of 82
 Date: Apr. 24, 2012

Temperature:	<u>22°C</u>	Humidity:	<u>51%RH</u>
Spectrum Detector:	<u>PK.</u>	Tested Mode:	<u>802.11g</u>
Tested By:	<u>Jeff Lo</u>	Modulation Type:	<u>64QAM</u>
Tested Date:	<u>Apr. 03, 2012</u>		

CHANNEL NUMBER	CHANNEL FREQUENCY (MHz)	RF POWER LEVEL IN 3kHz BW (dBm/3kHz)	MAXIMUM LIMIT (dBm/3kHz)
1	2412	-13.78	8
7	2442	-14.51	8
11	2462	-15.13	8

CH 1:

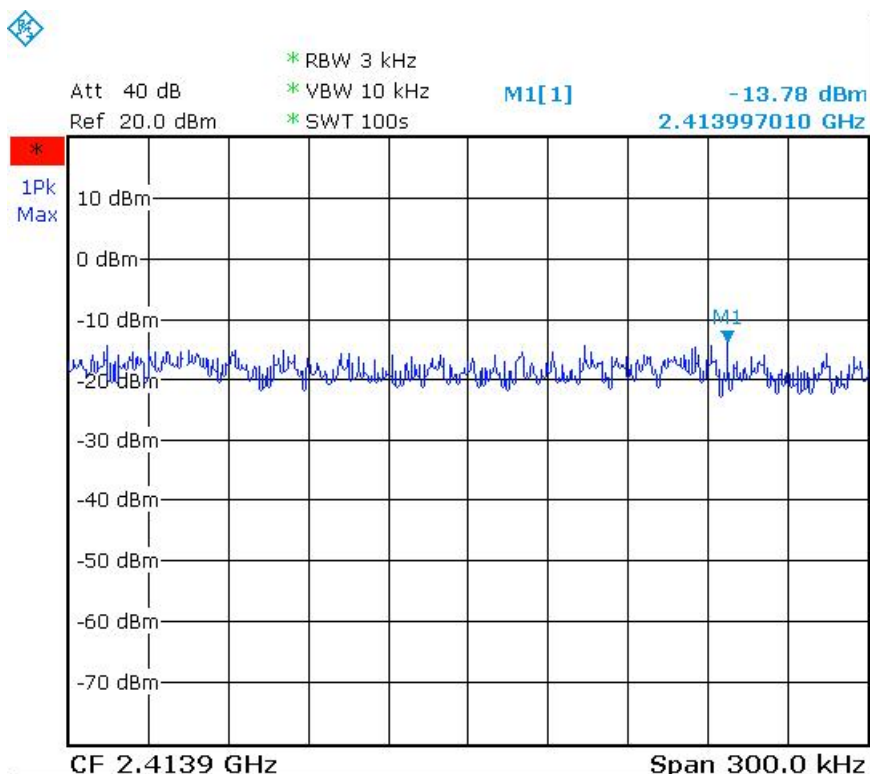



CH 7:

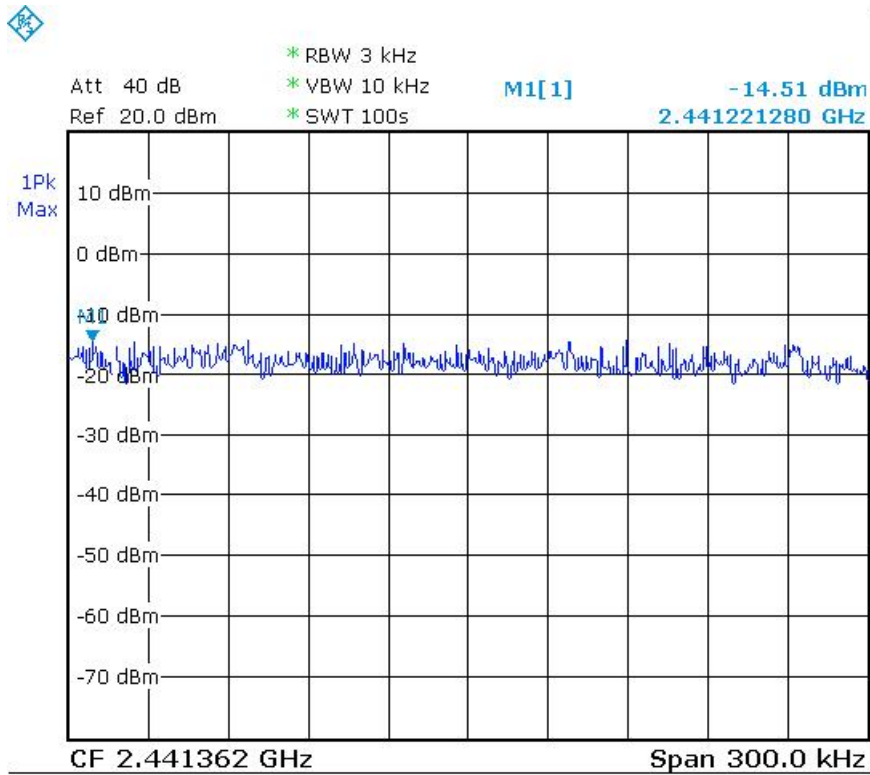

CH 11:

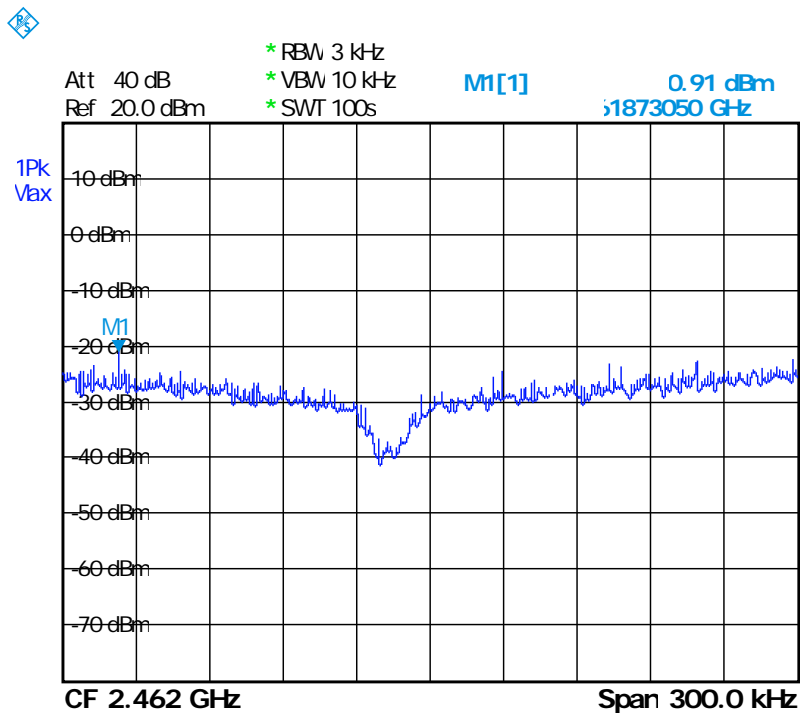



Spectrum Research & Testing Lab., Inc.
 No.167, Ln. 780, Shan-Tong Rd., Ling 8, Shan-Tong Li, Chung-Li City, Taoyuan County 320, Taiwan (R.O.C.)

TEST REPORT

Reference No.: A12030215
 Report No.: FCCA12030215
 FCC ID: JY8DW06
 Page: 76 of 82
 Date: Apr. 24, 2012

Temperature:	<u>22°C</u>	Humidity:	<u>51%RH</u>
Spectrum Detector:	<u>PK.</u>	Tested Mode:	<u>802.11n</u>
Tested By:	<u>Jeff Lo</u>	Modulation Type:	<u>OFDM</u>
Tested Date:	<u>Mar. 30, 2012</u>		

CHANNEL NUMBER	CHANNEL FREQUENCY (MHz)	RF POWER LEVEL IN 3kHz BW (dBm/3kHz)	MAXIMUM LIMIT (dBm/3kHz)
5	2422	-11.97	8
8	2437	-4.84	8
11	2452	-39.22	8

CH 5:

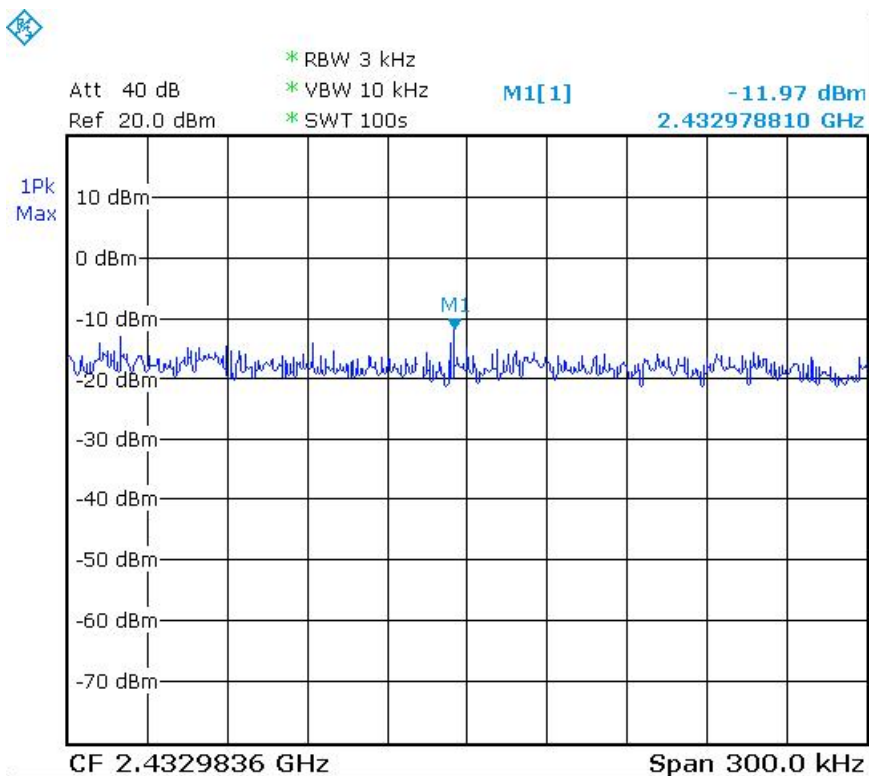



CH 8:

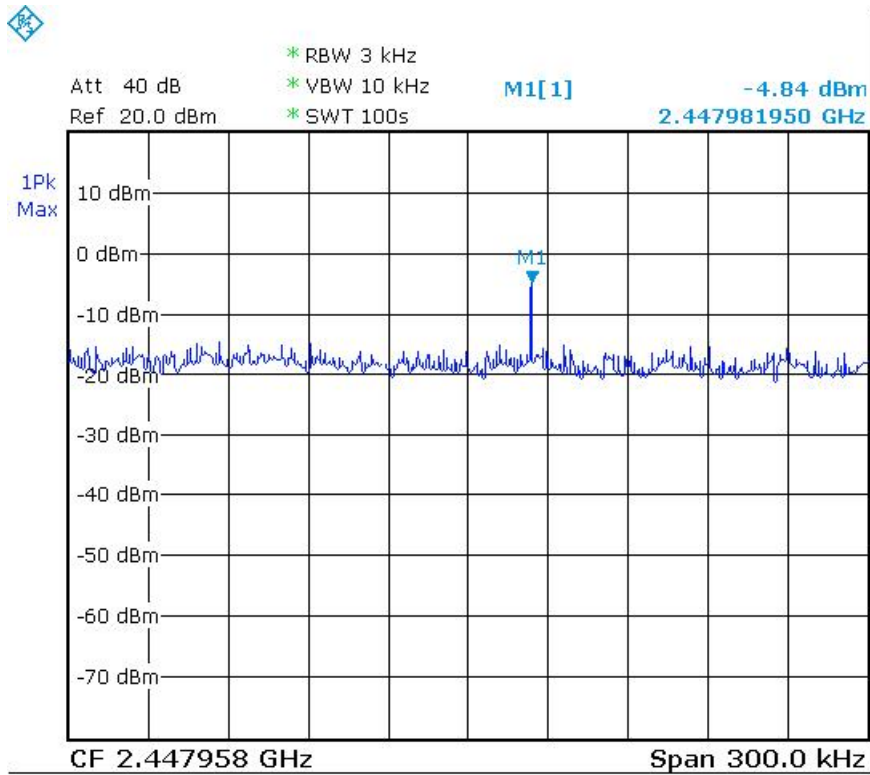

CH 11:

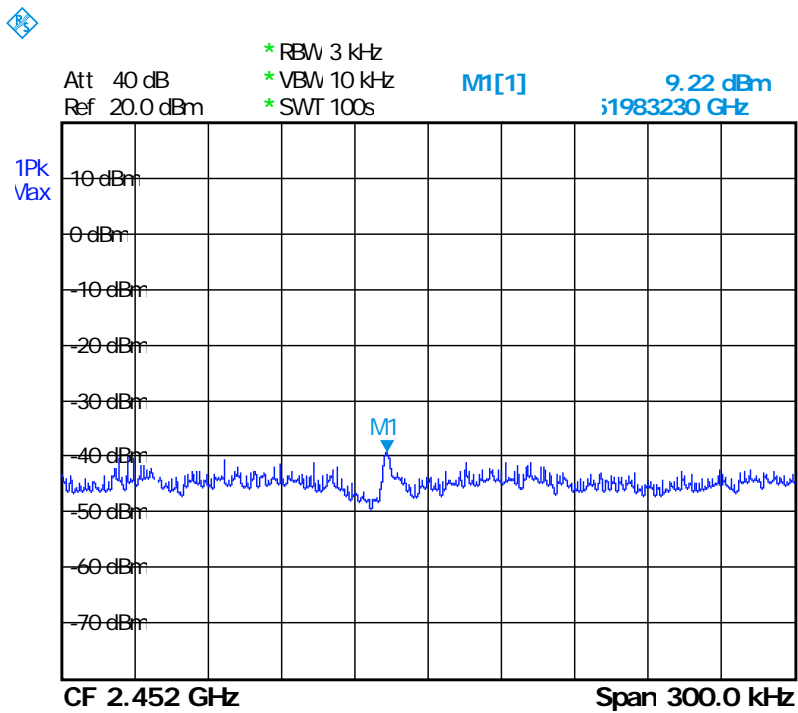



5 Antenna application

5.1 Antenna requirement

The EUT's antenna is met the requirement of FCC part15C section15.203 and 15.204.

FCC part15C section15.247 requirement:

Systems operating in the 2400-2483.5 MHz band that are used exclusively for fixed, point-to-point operations may employ transmitting antennas with directional gain greater than 6 dBi provided the maximum peak output power of the intentional radiator is reduced by 1 dB for every 3 dB that the directional gain of the antenna exceeds 6 dBi.

5.2 Result

The EUT antenna used a PIFA . Gain of antenna types is -3.22 dBi that meet the requirement.



6. PHOTOS OF TESTING

- Conducted test (TX+RX, normal used)





- Radiated test (below 1G , TX+RX , normal used)





**Spectrum Research
& Testing Lab., Inc.**
No.167,Ln. 780, Shan-Tong
Rd.,Ling 8, Shan-Tong Li,
Chung-Li City, Taoyuan County
320, Taiwan (R.O.C.)

TEST REPORT

Reference No.: A12030215
Report No.: FCCA12030215
FCC ID: JY8DW06
Page:81 of 82
Date: Apr. 24, 2012

- Radiated test (above 1G , TX+RX , normal used)





**Spectrum Research
& Testing Lab., Inc.**
No.167, Ln. 780, Shan-Tong
Rd., Ling 8, Shan-Tong Li,
Chung-Li City, Taoyuan County
320, Taiwan (R.O.C.)

TEST REPORT

Reference No.: A12030215
Report No.: FCCA12030215
FCC ID: JY8DW06
Page: 82 of 82
Date: Apr. 24, 2012

7. TERMS OF ABBREVIATION

AV.	Average detection
AZ(°)	Turn table azimuth
Correct.	Correction
EL(m)	Antenna height (meter)
EUT	Equipment Under Test
Horiz.	Horizontal direction
LISN	Line Impedance Stabilization Network
NSA	Normalized Site Attenuation
Q.P.	Quasi-peak detection
SRT Lab	Spectrum Research & Testing Laboratory, Inc.
Vert.	Vertical direction