



InstaShow™ S

User Manual

Copyright

Copyright © 2019 by BenQ Corporation. All rights reserved. No part of this publication may be reproduced, transmitted, transcribed, stored in a retrieval system or translated into any language or computer language, in any form or by any means, electronic, mechanical, magnetic, optical, chemical, manual or otherwise, without the prior written permission of BenQ Corporation.

Disclaimer

BenQ Corporation makes no representations or warranties, either expressed or implied, with respect to the contents hereof and specifically disclaims any warranties, merchantability or fitness for any particular purpose. Further, BenQ Corporation reserves the right to revise this publication and to make changes from time to time in the contents hereof without obligation of BenQ Corporation to notify any person of such revision or changes.

This user manual aims to provide the most updated and accurate information to customers, and thus all contents may be modified from time to time without prior notice. Please visit www.benq.com for the latest version of this manual.

The illustrations and the images in this guide are for your reference.

BenQ ecoFACTS

BenQ has been dedicated to the design and development of greener product as part of its aspiration to realize the ideal of the “Bringing Enjoyment 'N Quality to Life” corporate vision with the ultimate goal to achieve a low-carbon society. Besides meeting international regulatory requirement and standards pertaining to environmental management, BenQ has spared no efforts in pushing our initiatives further to incorporate life cycle design in the aspects of material selection, manufacturing, packaging, transportation, using and disposal of the products. BenQ ecoFACTS label lists key eco-friendly design highlights of each product, hoping to ensure that consumers make informed green choices at purchase. Check out BenQ's CSR Website at <http://csr.BenQ.com/> for more details on BenQ's environmental commitments and achievements.



RECYCLING

This product bears the selective sorting symbol for Waste electrical and electronic equipment (WEEE). This means that this product must be handled pursuant to European directive 2012/19/EU in order to be recycled or dismantled to minimize its impact on the environment. User has the choice to give his product to a competent recycling organization or to the retailer when he buys a new electrical or electronic equipment.

 This symbol indicates DC voltage

Table of contents

Copyright	1
Disclaimer	1
BenQ ecoFACTS	1
Introduction	3
Product features	3
Package content	4
Product specification	5
Overview	7
Button	7
Host	7
LED indicators of the Button and Host	8
Installation	9
Environment check	9
Assembling the Host	10
Setting up the Host	10
Attaching the Host to the ceiling	10
Attaching the Host to a ceiling mount.....	11
Placing the Host on a table	11
Installing the Host on the wall or trolley	13
Positioning the Host antennas	14
For ceiling installation	14
For ceiling mount installation	14
For table placement	15
Connecting the HDMI cable and power	15
Assembling the adapter	16
Connecting the HDMI cable.....	17
Power supply via a power adapter	17
LAN connection	18
Setting up and powering a Button	18
Using Cable USB A(F) to USB A(M)	20
Pairing a Button and Host	21
When the Host is placed on a table	21
Storing Buttons and USB cable in the cradle	23
Resetting an Host	23
Resetting a Button	24
Starting and stopping presentations	26
Getting ready	26
Starting presentation	26
Idle presentation	27
Split screen presentations	28
Starting a split screen presentation	28
Switching from a split screen to a full screen presentation	29
Presenting with mobile devices	29
Controlling presentations	30
Troubleshooting	31

Introduction

InstaShow™ S (shortened as the “Product” in this document) is a wireless device for corporate meeting rooms. Users expect devices to respond instantly, apps to launch and to control at their fingertips, and information to be available on demand. The product bypasses the complicated steps of IP addresses, driver installation, app execution, setting selection, etc. to quickly deliver professional, stable visual quality for teams to collaborate freely and confidently. The product is an unique all-hardware solution without software issues for universal compatibility and display flexibility.

A standard product set consists of an InstaShow™ S Host (shortened as “Host” in this document) and two InstaShow™ S Buttons (shortened as “Button” or “Buttons” in this document). Depending on the location where you buy the product, the software of the base unit can be different. You can buy additional Button kit if needed.



Product features

The product is equipped with the following features:

Features	Description
True Plug & Play	Simply connect the product into your USB and HDMI ports, then push the button to start presenting immediately.
No Software	The product doesn't need any software installation or execution. There's no setup, configuration, or waiting for pop-ups to launch. Just plug into your PC or Mac and start presenting immediately.
Split Screen Presentations	Up to four users can simultaneously project their screen via the product in a dual-screen, 3-way or 4-way split screen configuration, so that you can view and reference multiple documents/videos at the same time during your presentation.
Auto Channel Selection	The product automatically selects the best wireless channel upon boot-up, ensuring smooth presentations in any environment.

Features	Description
Touch back	When the Host is connected to a touchscreen display via its USB ports, you can use the touchscreen to control the screen of the PC that is presenting, allowing you to actively engage with the content that is being presented.
Screen Casting for Mobile Devices	Project your mobile device's screen wirelessly by connecting your mobile device to the Host via the InstaShare app (for both Android and iOS devices).
Wireless 802.11ac/n	The latest 802.11ac/n Wi-Fi guarantees extremely smooth wireless streaming without lag or buffering.
Video and Audio	The product's HDMI output supports up to 60Hz Full HD 1080p video and stereo sound without cable clutter or complicated driver selection.
Assured Performance	Peace of mind for consistent wireless presentation performance without relying on your PC.
Extended Desktop	Keep your presenter view, notes, and backup data on your laptop screen while presenting to the wireless screen with extended desktop in both Windows and OS X.



- Touch back via USB port is only supported for PCs. Macs and mobile devices cannot be controlled via touch screens.
- Transmission distance depends on actual environment. Stated distance is based on line-of-sight measurement. Structures constructed of steel, wood, concrete, or brick may decrease transmission distance.
- According to regulatory restrictions in different regions of the world, Wi-Fi channels cannot be used in countries outside the purchased region.

Package content

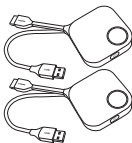

InstaShow™ S Buttons

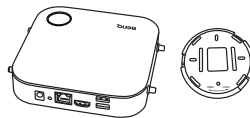

InstaShow™ S Host and Lid

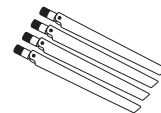

4 Antennas

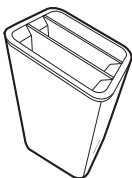

Cradle

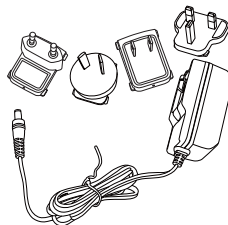

Adapter & Plugs

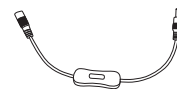

Extender Power Cable

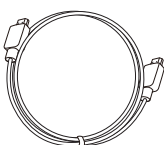

Cable: HDMI A(M) to A(M)

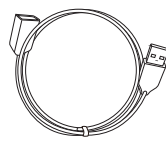

Cable: USB A(F) to USB A(M)



Screws & Rubber Foot

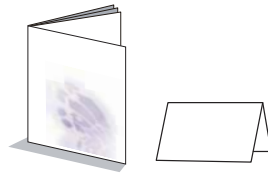
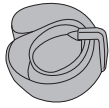

Velcro Strap

Quick Start Guide & Safety Statement



- Available accessories and the pictures shown here may differ from the actual contents and the product supplied for your region.
- Use original accessories to ensure compatibility.
- Always keep the product and accessories out of reach of children.

Product specification

Feature			
Color	Black		
Video outputs	HDMI 1.4, comply with HDCP		
Frame Rate	Up to 60fps depending on environment		
Output resolution	720x568, 1280x720 (720P), 1920x1080 (1080p)		
Input resolution	Up to 1920x1080		
Number of simultaneous connections	32 pcs		
Audio	Stereo, Radio quality 16bits 48KHz		
Wireless transmission protocol	IEEE 802.11ac, 5GHz, 2T2R IEEE 802.11n, 2.4GHz, 2T2R		
Data rate wireless	Up to 867 + 300Mbps		
Frequency Band	2.4GHz, 5GHz		
Authentication protocol	WPA2 (WPAS-PSK (Pre-Shared key) / WPA2-Enterprise)		
Security (encryption)	AES 128 bit		
Support platform	Windows, MAC, Chrome. Any OS supporting HDMI standard 1.4		
Reach	Max. 15M between the Button and the Host		
Temperature range	Operating: 0°C to +40°C (+32°F to +104°F)		
	Storage: -10°C to +60°C (+14°F to +140°F)		
Humidity	Storage: 5% to 90% relative humidity, non-condensing		
	Operation: 10% to 80% relative humidity, non-condensing		
InstaShow™ S Button			
Cable	USB Type A, HDMI Cable	Power supply	DC 5V±10%, 0.5A
Reset button	x1	Power consumption	Normal: 2.5W
Split screen key	x1	Dimension	With cable: 81x291x24.2mm Without cable: 67x67x24.2mm
LED	Red (error), Green (Wi-Fi connected), Blue (presenting)	Weight	81g
InstaShow™ S Host			
Standby button	x1	Power supply	DC 12V±10%, 2A

Feature			
Pairing key	x1	Power consumption	Normal: 24W
WAN	x1		
Video output	x1 HDMI 1.4 (video and audio)		
DC Power Jack	x1	Dimension (WxHxD) (not including rubber feet)	With antennas: 200x140x150mm Without antennas: 154x140x34mm
LED	Red (error), Green (ready for connection), Blue (presenting)	Weight (include antenna)	330g
Cradle			
Dimension	100.4x92.6x152mm	Weight	550g

Overview

Button

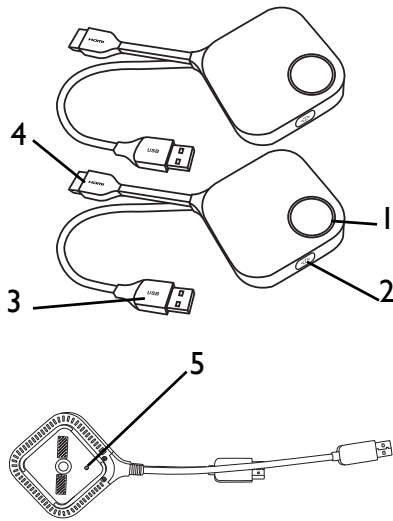

Bottom of Button

1. **Present key with LED indicator**
Press to start or stop presenting.
2. **Split screen key**
Press to enable split screen presentations.
3. **USB 3.0 connector**
Connect to a computer or laptop.
4. **HDMI 1.4 connector**
Connect to a computer or laptop.
5. **RESET**
Poke the **RESET** hole to reset the device if the device stops responding. Refer to [Resetting an Host on page 23](#) for more information.

Host

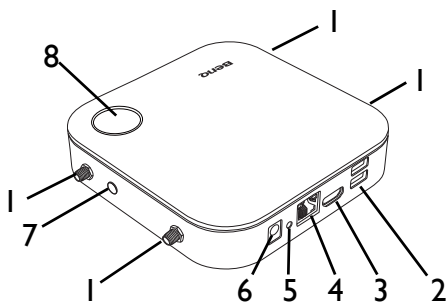

1. **Fixture parts for the Antennas**
Refer to [Assembling the Host on page 10](#) for more information.
2. **USB-A Ports**
Connect to a touchscreen display, mouse, or keyboard, to control the projected screen.
3. **HDMI port**
Connect to a display using a Cable HDMI A(M) to A(M).
4. **LAN port**
Allows users access to the web management interface through a direct or network connection.
5. **RESET**
Poke the **RESET** hole to reset the device if the device stops responding. Refer to [Resetting a Button on page 24](#) for more information.
6. **DC 2A port**
Connect to the supplied adapter extender power cable and adapter to power the Host.
7. **PAIRING key**
Press to pair with a Button.
8. **Standby button with LED indicator**
Press to turn the Host on and off.

9 Lid of Host

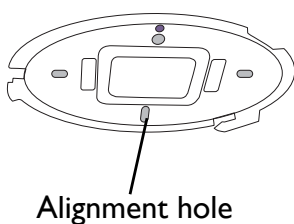

9. Lid

Refer to [Attaching the Host to the ceiling on page 10](#) for more information.

LED indicators of the Button and Host

Please refer to the tables below for detailed indicator and status descriptions for the Button and Host.

LED indicator on the Button	Status Description
Static blue	The device is presenting.
Flashing blue	The device is in the process of pairing
Flashing green	<ul style="list-style-type: none"> The device is starting up and connecting to the host. The device is upgrading the firmware.
Static green	The device is connected and working normally.
Flashing red	The device is unable to connect to a host.
Off	The device is powered off.
Static red	The device is resetting.
Quick flashing red	The reset process is triggered.

LED indicator on the Host	Status Description
Static blue	Connected device is presenting.
Flashing blue	The device is in the process of pairing.
Flashing green	<ul style="list-style-type: none"> The device is starting up. The device is upgrading the firmware.
50% static green	The device is in network standby mode.
Static green	The device is on and ready for connection.
Flashing red	The device is encountering a problem.
Static red	The device is resetting.
Off	The device is powered off.
Quick flashing red	The reset process is triggered.

Installation

This section will guide you on how to prepare the unit before its initial use.

Environment check

Before installing the product, check the environmental conditions.

1. Do not install the device near heat sources like radiators or direct sunlight, or in a site with excessive dust or humidity.
2. Ambient temperature conditions are listed as below. Maximum ambient temperature should be +40°C or 104°F. Minimum ambient temperature should be +0°C or 32°F. Storage temperature should be -10°C to +60°C (14°F to 140°F).
3. Humidity conditions are listed as below. For storage, the relative humidity should be 5% to 90% (non-condensing). For operation, the relative humidity should be 10% to 80% (non-condensing).

As the product works with different displays, the steps required to complete the installation may vary according to the actual environment and your display specifications. Follow the procedures below and refer to the specified sections for details.

1. Assemble the Host with the antennas. See [Assembling the Host on page 10](#) for details.
2. Connect the Host to the display and power properly. See [Connecting the HDMI cable and power on page 15](#) for details. Four installation methods are provided.
 - Attaching the Host to the ceiling
 - Attaching the Host to a ceiling mount
 - Placing the Host on a table
 - Installing the Host on the wall or trolley
3. Connect the Button to the desired devices and power properly. See [Setting up and powering a Button on page 18](#) for details.
4. Make sure that all the connected devices have been powered on. Press the source button of the display and make sure that the HDMI source has been transmitted. See [Pairing a Button and Host on page 21](#) for details.

Assembling the Host

Assemble the Host with four antennas by turning the antennas clockwise (right) and counterclockwise (left) to fasten them tightly.

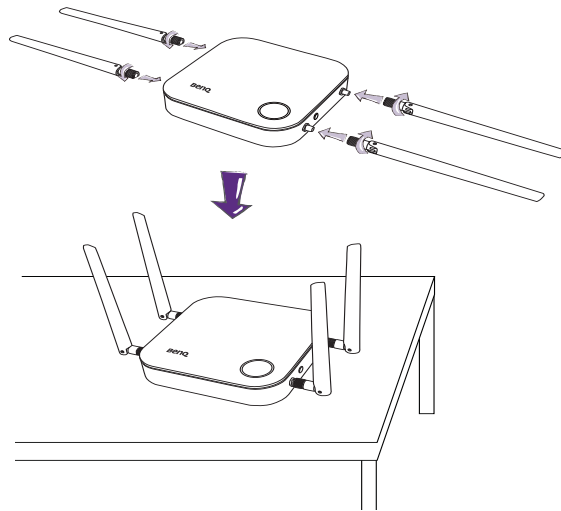

Setting up the Host

You are provided with four different ways to position the Host. The total weight of the Host Unit is 330g.

Attaching the Host to the ceiling

1. Place the lid on the ceiling and locate the alignment hole.
2. Use the screws provided to lock the lid to the ceiling.
3. Lock the first hole (1).
4. Follow the instruction in the illustration below to lock the other holes (2-4).
5. Rotate the Host counterclockwise to affix the Host to the lid..

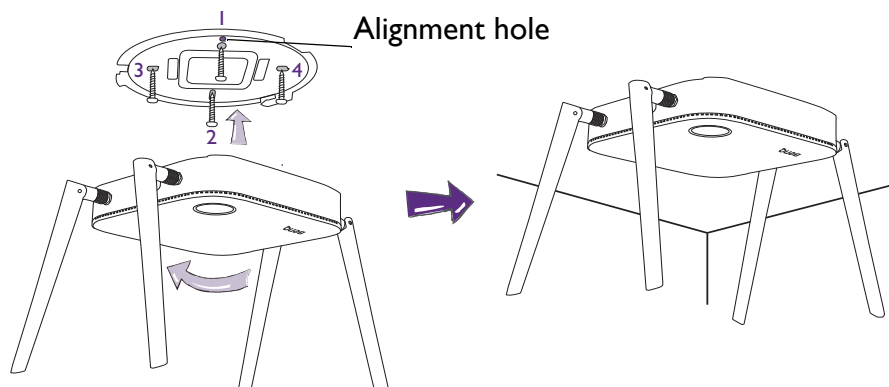

- Please only use the screws (M3*16 tapping screw) provided with the kit to mount the Host to the ceiling.
- Please see [Positioning the Host antennas on page 14](#) for guidelines on positioning the antenna to maximize signal reception.

Attaching the Host to a ceiling mount

If the display is mounted on the ceiling:

1. Attach the Host to the ceiling mount using the provided velcro strap.
2. Fix the Host to the mounting holder.
3. Use the supplied velcro to fix the mounting holder and the Host to the ceiling mount as shown in the illustration.

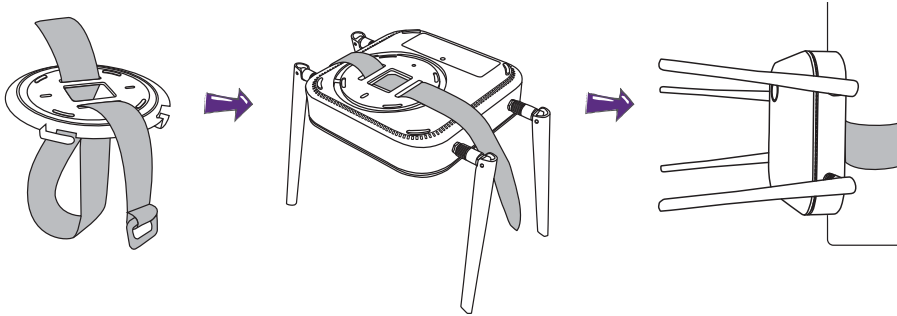

- Please only use the velcro strap (300(L)mm*25(W)mm) provided with the kit to mount the Host to a ceiling mount.
- Please see [Positioning the Host antennas on page 14](#) for guidelines on positioning the antenna to maximize signal reception.

Placing the Host on a table

If your display is placed on a table, first attach the lid of to the Host in the following the process described below:

1. Align the lid over the bottom of Host so that the triangle on the bottom side of the lid is aligned to the triangle in the lid compartment, then insert the lid into the lid compartment.

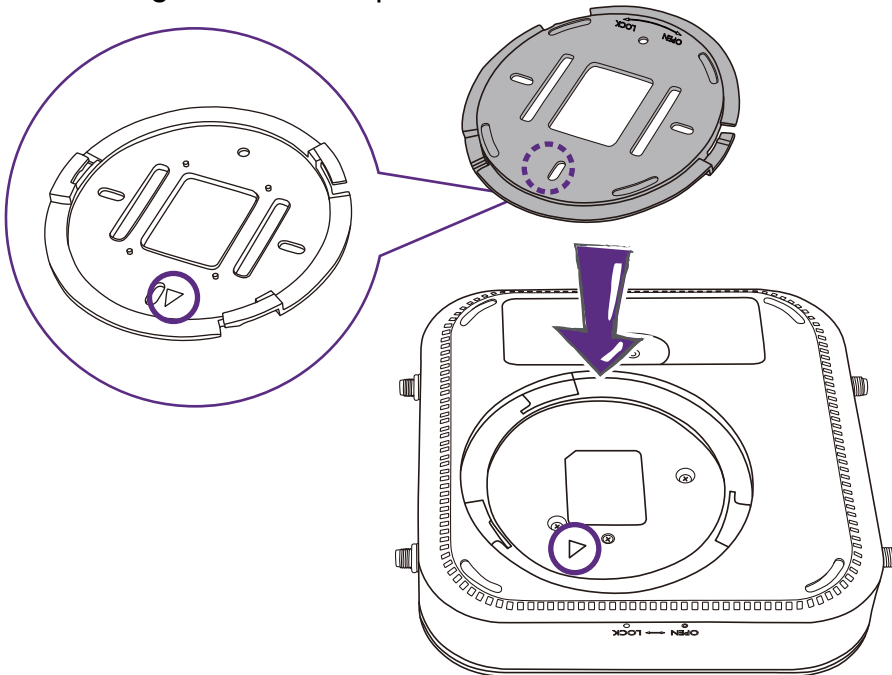

2. Turn the lid counter-clockwise until it clicks into place.

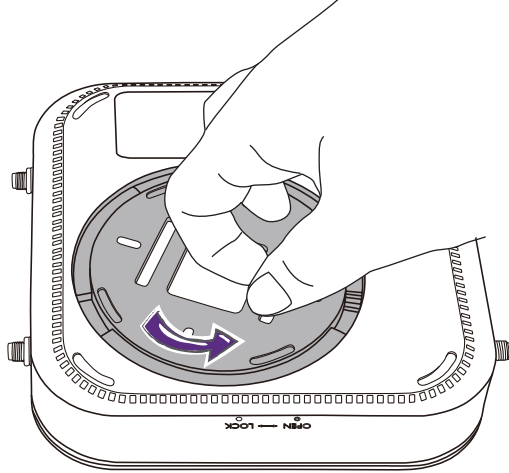

3. When the lid is correctly installed on the Host the alignment hole on the lid should be pointed to the **LOCK** print at the front side of the Host.

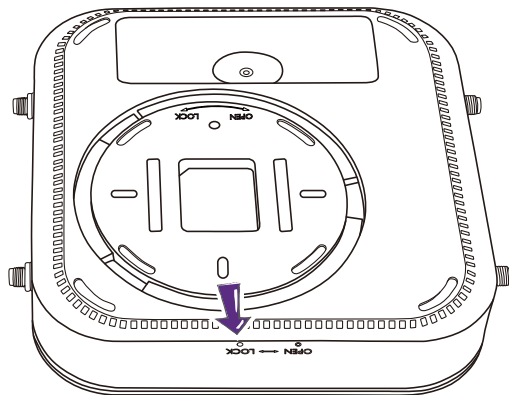

4. Attach the rubber feet to the recesses on the lid and put the Host right next to the display.

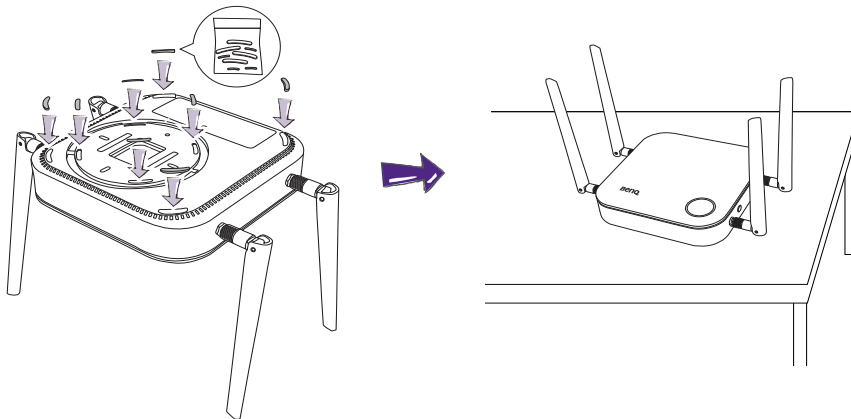

- Please only use the rubber foot provided with the kit to attach to the Host.
- Please see [Positioning the Host antennas on page 14](#) for guidelines on positioning the antenna to maximize signal reception.

Installing the Host on the wall or trolley

If you need to install the Host near a display:

1. Stick double-sided tape to the lid of the Host.
2. Affix the Host on the wall near the display.
3. Keep the antennas away from any signal obstructions.

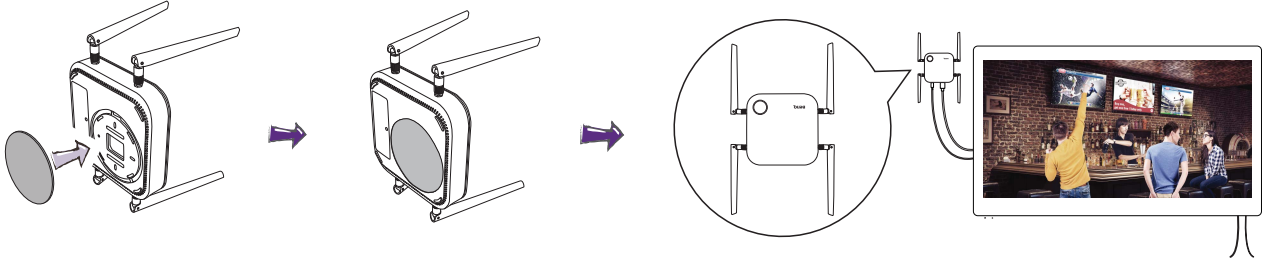

You can also place the Host on a mobile display trolley. See the illustration.



- Please only use double-sided sponge tape on the lid of the Host.
- Please wait 24 hours after you attach the double-sided sponge tape to the lid of the Host.

Positioning the Host antennas

Once you have properly installed the Host, follow the guidelines below to position the antennas to maximize signal reception:

For ceiling installation

Position the antennas so that they are both pointed downwards at an angle roughly perpendicular to the ceiling:

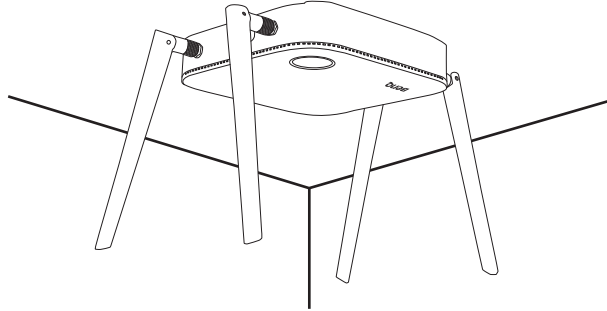

For ceiling mount installation

- Position the antennas so that they are both point either upwards or downwards roughly parallel to the ceiling mount:

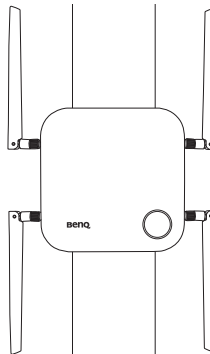

- If you encounter bad signal reception after initial use of the Host you can manually adjust the antennas so that they tilt at a slight angle to maximize signal reception. When doing so, avoid tilting the antennas toward the ceiling mount:

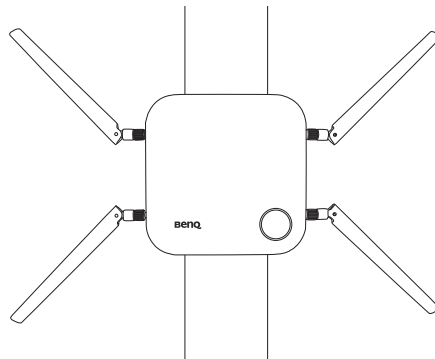

- Avoid positioning the antennas in a horizontal manner, this may result in a weak signal reception:

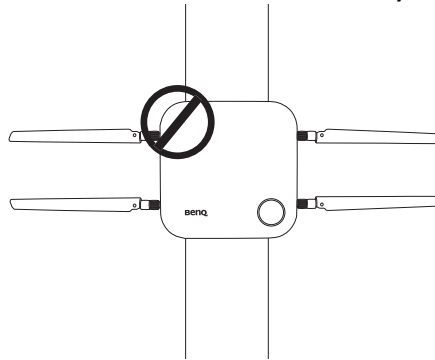

- If the Host is attached to a metallic ceiling mount ensure that the antennas are at least 3 cm away from the metal portion of the ceiling mount:

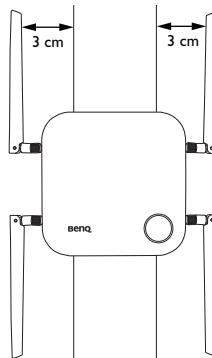

For table placement

Position the antennas so that they are both pointed upwards roughly perpendicular to the table:

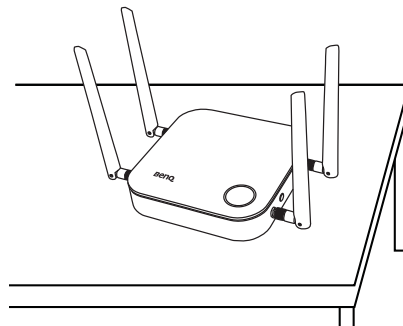

Connecting the HDMI cable and power

Once the Host has been positioned properly near the display, connect the HDMI cable and power to ensure signal transmission.

Assembling the adapter

Every adapter provided in the box includes a plug socket and plugs based on the region in which you purchased the product. Below are images of the standard American, standard European, standard Australian, and standard UK plugs:

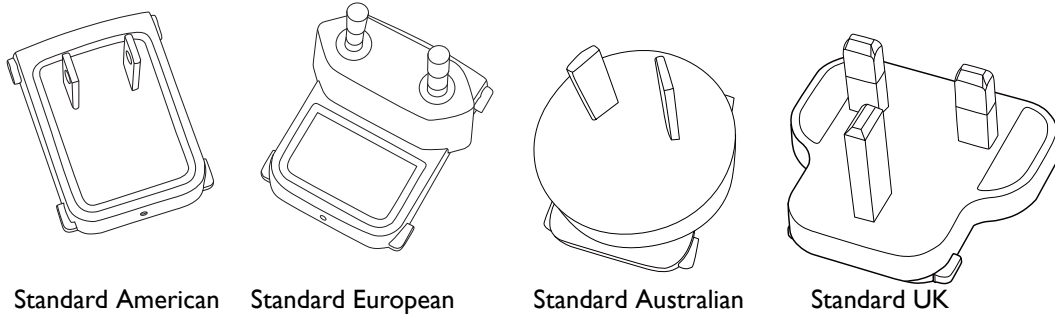

To connect the plug of your choice, follow the steps below.

1. Align and insert the plug into the adapter.
2. Push the plug all the way in until it clips into place.

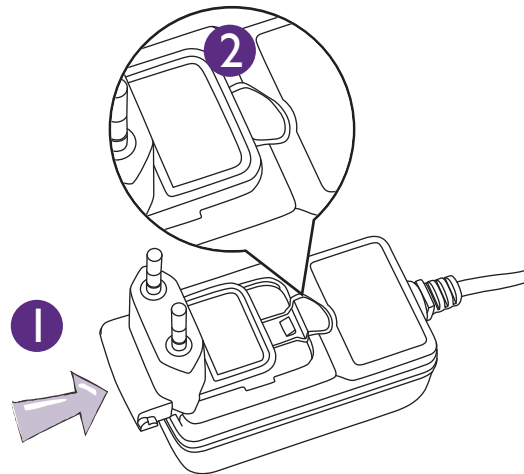

To disconnect the plug, follow the steps below.

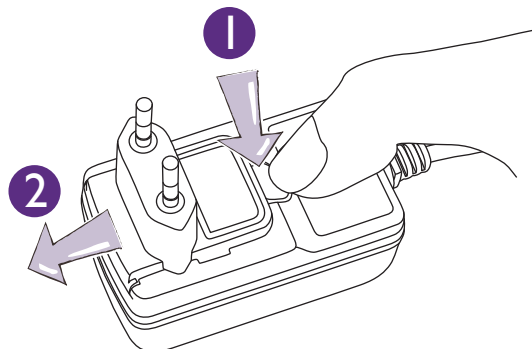

1. Push the latch in the middle.
2. Detach the plug by pushing it outward and remove the plug.

Connecting the HDMI cable

Connect the HDMI cable to the HDMI out jack of the Host and the HDMI input jack of the projector.

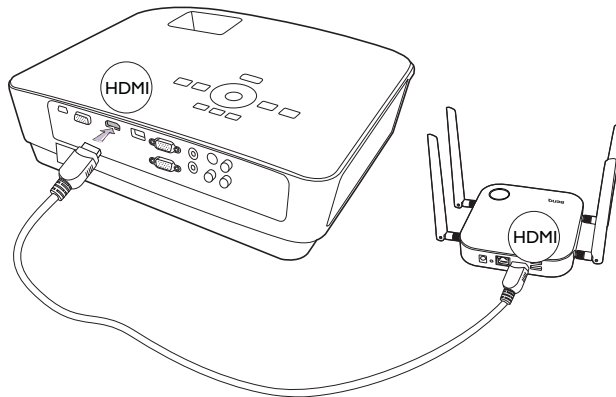

Power supply via a power adapter

Connect the male connector of the extender power cable to the power jack of the Host, then connect the supplied power adapter to the female connector of the extender power cable, and then plug the other end of the power adapter into a wall socket. Once the connection is set up press the power switch on the extender power cable to supply power to the Host, the LED indicator on the standby button of the Host lights up static green when the power is supplied.

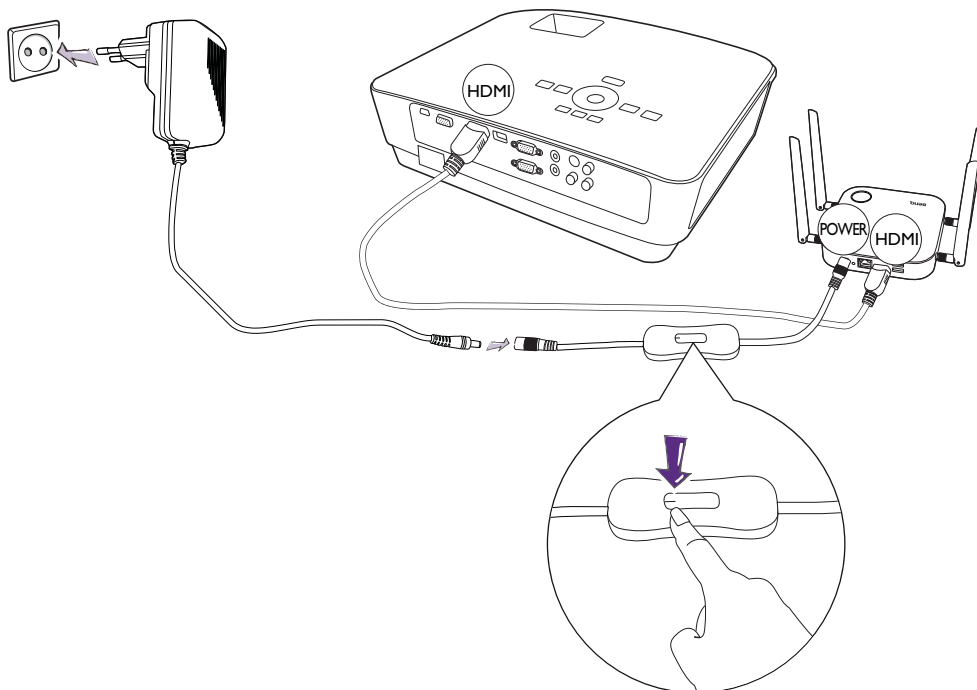

For BenQ IFP (Interactive Flat Panel) products, please have power supplied via a power adapter.

LAN connection

The Host can be connected to a local network or directly to a laptop. The LAN connection can be used to configure the product and update the software. Insert a network cable with RJ-45 connectors into the LAN port and connect the other side to a LAN.

Setting up and powering a Button

1. Connect the Button's HDMI and USB jacks to the corresponding inputs of a laptop. See the illustration.

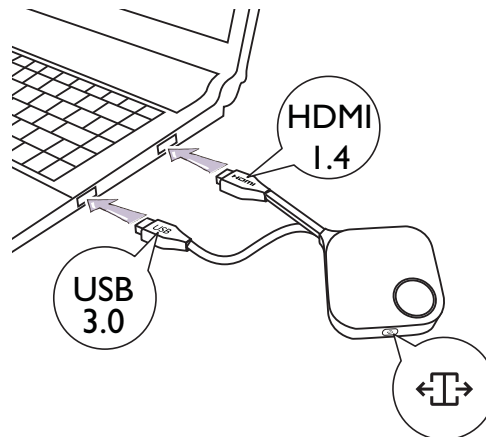

2. The LED indicator of the Button will flash green while the Button is starting up.



3. When the button is ready to present, the LED indicator will turn solid green. Press the Present key when the LED indicator turns green.

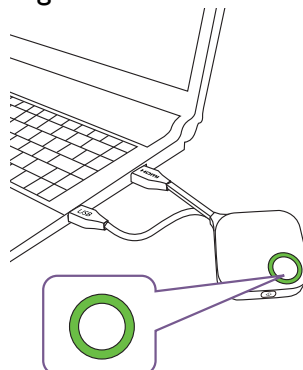

- If the button encounters problems while pairing with the Host during startup the LED indicator will flash red. Repeat the previous the process again until the LED turns solid green. See [LED indicators of the Button and Host on page 8](#) for more information on LED behavior.
- Handle the Button cable with care. Rough handling might cause defects.
- Pull/Push the plug instead of the cable when inserting or removing Buttons.

If you purchase an additional Button (via an Kit), please follow the process described below:

1. Follow the pairing instructions described in [Pairing a Button and Host on page 21](#).
2. Connect the Button's HDMI and USB jacks to the corresponding inputs of a laptop. See the illustration.

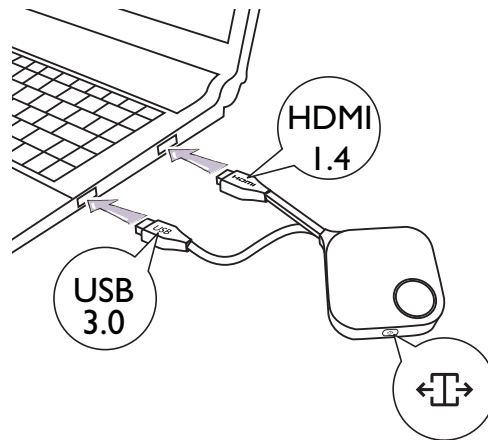

3. The LED indicator of the Button will flash green while the Button is starting up.



4. When the Button is ready to present, the LED indicator will turn solid green. Press the Present key when the LED indicator turns green. .

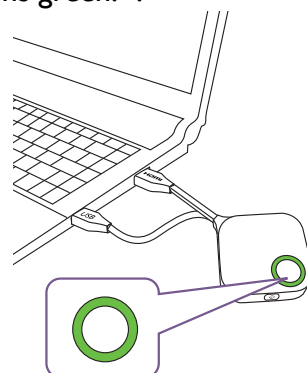

- Handle the Button cable with care. Rough handling might cause defects.
- Pull/Push the plug instead of the cable when inserting or removing Buttons.

Using Cable USB A(F) to USB A(M)

A USB cable is provided for MacBook and Windows laptop users.

1. Insert the HDMI cable of the Button to the HDMI converter of your laptop.
2. Connect the cable USB A(F) to your laptop.
3. Connect the Button's USB jack to the Cable USB A(M).

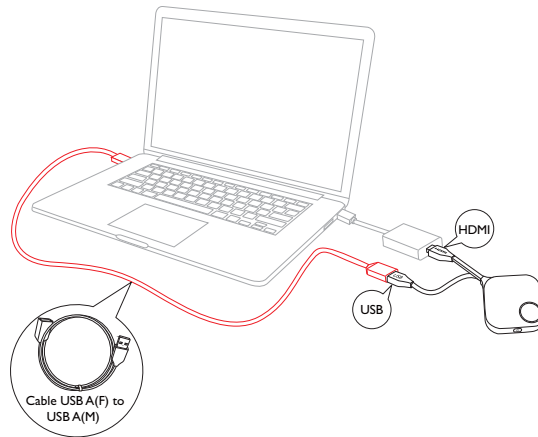

Make sure your own HDMI converter is workable.

Pairing a Button and Host

The product includes an Host and two Buttons, which are paired before shipment. In such a case, you don't need to pair them again. However, if you buy two or more sets of InstaShow™ S, and you want to pair a Button with a different Host, you need to follow the instruction below. If you buy an additional Button Kit, and you want to pair the new Buttons with your Host, you need to follow the instruction below as well.

When the Host is placed on a table

1. Make sure your Host is ready with power supply. Connect the Button's HDMI and USB jacks to the corresponding inputs of a laptop.

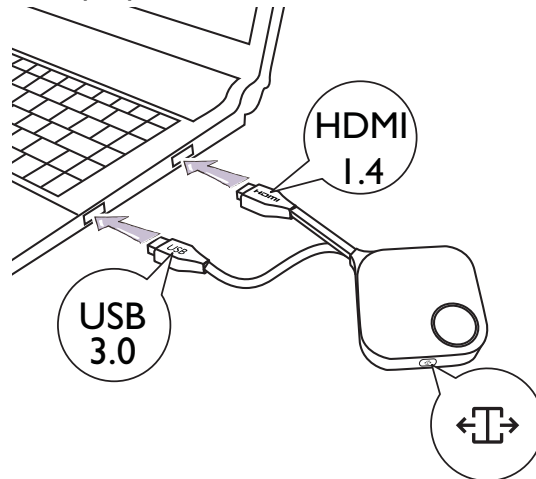

2. When the Button is connected to the laptop, the LED indicator of the Button will flash red. The Button is in pairing mode, waiting to pair with your Host.

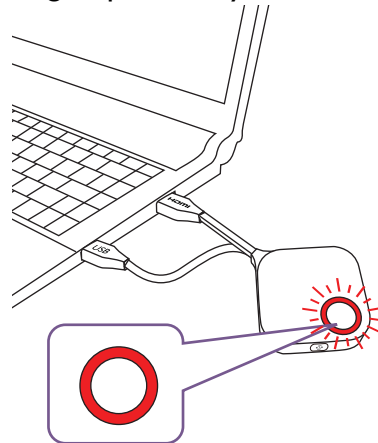

If a Button nearby has been paired with a Host before, it will turn static green.

3. Press the **PAIRING** key of the Host for five seconds, the LED indicator of the Host will blink blue for two minutes, waiting to pair with a Button.

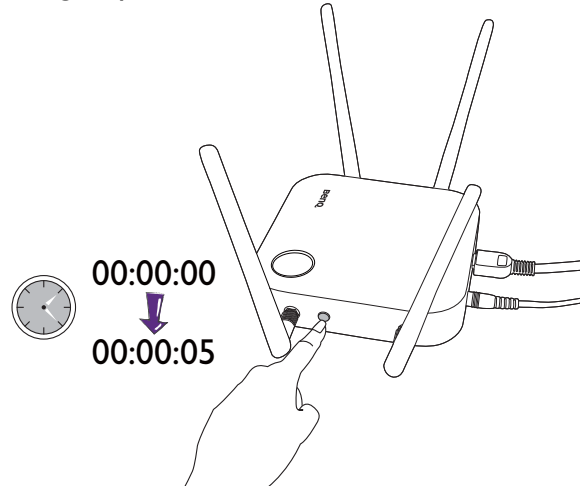

4. Press the split screen key on the side of the Button for five seconds. The LED indicator of the Button will blink blue for about 10 seconds. The pairing process is ongoing. The “Pairing in progress” message will be shown on the screen.

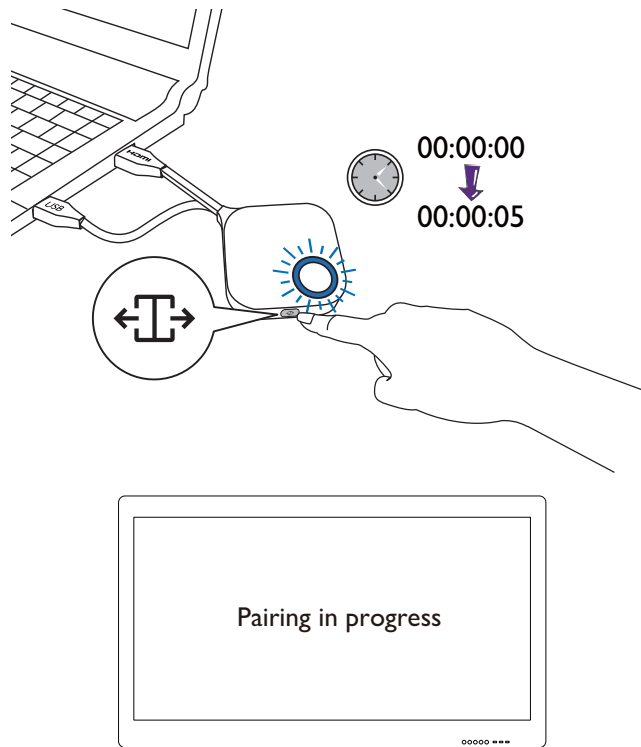

The images are for reference only. Each product has different serial number.

- The LED indicator of the Button turns static green and a “Pairing complete” message will be shown when the Host and Button are successfully paired.

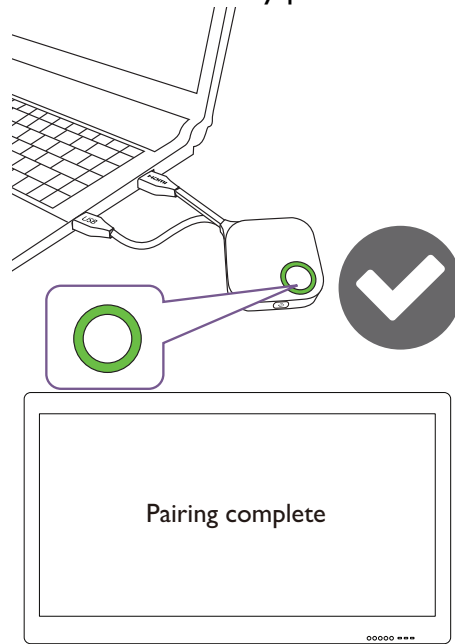

The maximum number of Buttons you can pair with one Host is 32.

Storing Buttons and USB cable in the cradle

You are provided with two different ways to store the Buttons in the cradle. Place the Buttons in the cradle vertically (1) or horizontally (2). See the illustrations.

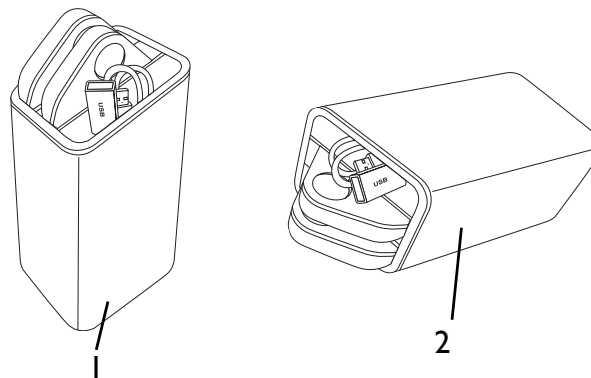

Resetting an Host

Resetting an Host allows you to return the Host to its original factory settings.

Reset the Host using the following steps:

1. Connect the power port on the Host to a power source and wait for at least 30 seconds.



After the Host has been connected to a power source for at least 30 seconds, the Host LED may indicate any one of the statuses described in [LED indicators of the Button and Host](#). As long as the Host has been connected to a power source for at least 30 seconds, you may proceed to the next step of the resetting process regardless of the status of the Host LED.

2. Poke the **RESET** hole at the rear of the Host with a pin for at least 2 seconds.

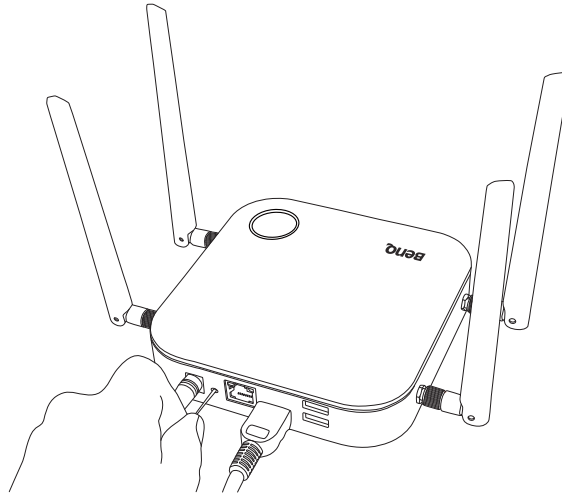

3. The Host LED will begin quick flashing red (flash red twice every second) for 10 seconds, then light up static red for 15 to 20 seconds, indicating that the Host is resetting.
4. Once the Host LED lights up static green the resetting process is complete.



Do not disconnect the Host from its power source at any time during the resetting process.

Resetting a Button

Resetting a Button allows you to return the Button to its original factory settings. You may want to reset a Button because of either one of the following conditions:

- You purchased an additional Button (via a Button Kit) which has not been paired to a Host.
- A Button that was included in the original package has been paired to a different Host (one which was not originally included with the Button in the package), and you want to quickly pair it back to its original Host.
- A Button that was included in the original package has been paired to a different Host (one which was not originally included with the Button in the package), and you want to re-pair the Button to its original Host while the Host is not powered on.

Reset a Button using the following steps:

1. If the original Host is powered on, place the Button within range of the original Host and ensure the LED on the Host is static green.

2. Connect the USB 3.0 connector on the Button to a powered on laptop and wait for at least 30 seconds.



After the Button has been connected to a powered on laptop for at least 30 seconds, the Button LED may indicate any one of the statuses described in [LED indicators of the Button and Host](#). As long as the Button has been connected to a powered on laptop for at least 30 seconds, you may proceed to the next step of the resetting process regardless of the status of the Button LED.

3. Poke the **RESET** hole at the bottom of the Button with a pin for at least 2 seconds.

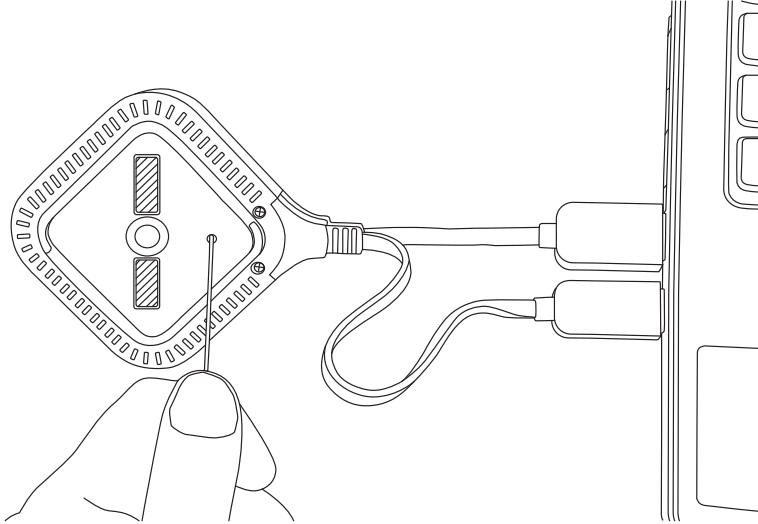

4. The Button LED will begin quick flashing red (flash red twice every second) for 10 seconds, then light up static red for 15 to 20 seconds, indicating that the Button is resetting.
 5. Once the Button LED lights up static green the resetting process is complete.
-



Do not disconnect the Button from its power source at any time during the resetting process.

Starting and stopping presentations

This section will guide you on how to start and stop a presentation using the product.

Getting ready

Make sure that all the connected devices have been powered on and ready for the presentation.

As the product could work with different projectors, IFPs, TVs, or monitors with standard HDMI ports, the steps required to start a presentation may vary according to the actual environment and your display specifications. Follow the procedures below and refer to the specified sections for details.

1. To start a presentation, see [Starting presentation on page 26](#) for details.
2. To stop a presentation, see [Idle presentation on page 27](#) for details.
3. To start a split-screen presentation, see [Split screen presentations on page 28](#) for details.
4. To start a presentation with a mobile device, see [Presenting with mobile devices on page 29](#) for details.
5. To control presentations via a touchscreen displays or mouse/keyboard see [Controlling presentations on page 30](#) for details.

Starting presentation

1. Make sure power is supplied to the Host. See [Connecting the HDMI cable and power on page 15](#) for more information.
2. Choose the HDMI source corresponding to the Host on the display. You will see the Guide screen.



3. Please follow the instruction on the Guide screen to supply power to the Button. You can also see [Setting up and powering a Button on page 18](#) for more information. The LED indicator on the Button is static green when the Button is connected and working properly.
4. To start a presentation, press the Present key.

5. The device starts presenting, and the LED indicator of the Button turns static blue.

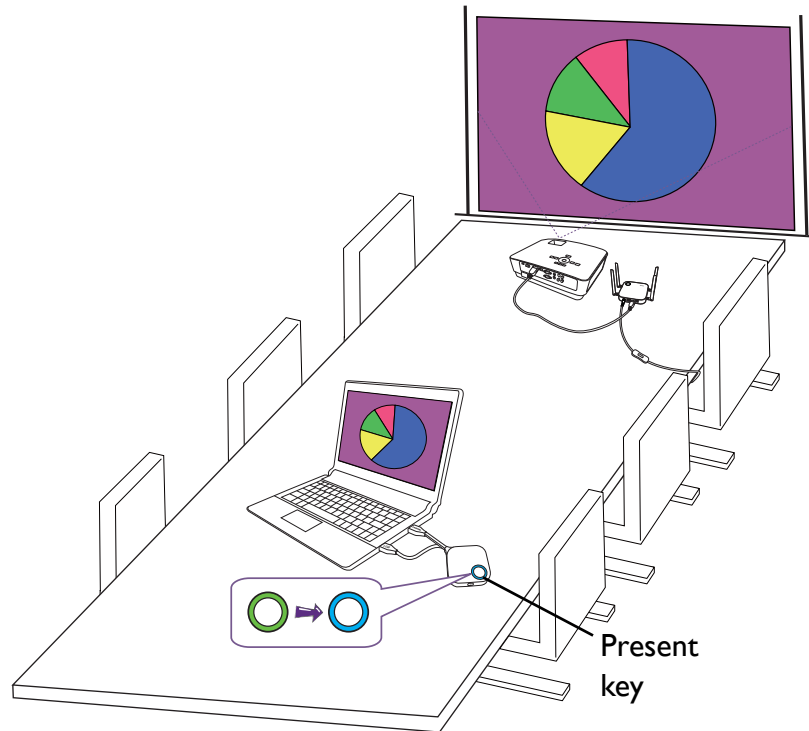

- Make sure the transmission distance between the Button and Host is within 15M and with no obstacles.
- The product supports MacBooks and Windows laptops to mirror an extended desktop.

Idle presentation

1. To stop a presentation, press the Present key.
2. The device stops presenting, and the LED indicator of the Button turns green.
3. Users can press the Present key to return to the presentation.

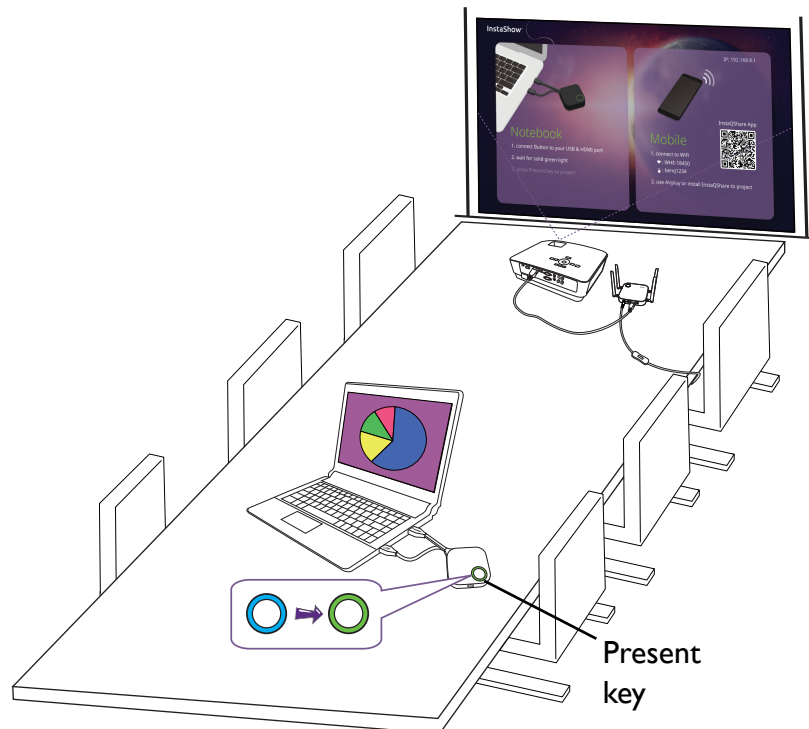

Split screen presentations

The product allows up to 4 users to present simultaneously in a split screen orientation.

Starting a split screen presentation

1. Connect a Button to each computer that will be presenting in the split screen presentation. See [Setting up and powering a Button on page 18](#) for more information.



Make sure that all Buttons have already been paired to the Host projecting the presentation. See [Pairing a Button and Host on page 21](#) for more information.

2. Start a normal presentation using one of the Host buttons. See [Starting presentation on page 26](#) for more information.
3. Press the split screen button on the Host that started the presentation to enable split screen presentations.

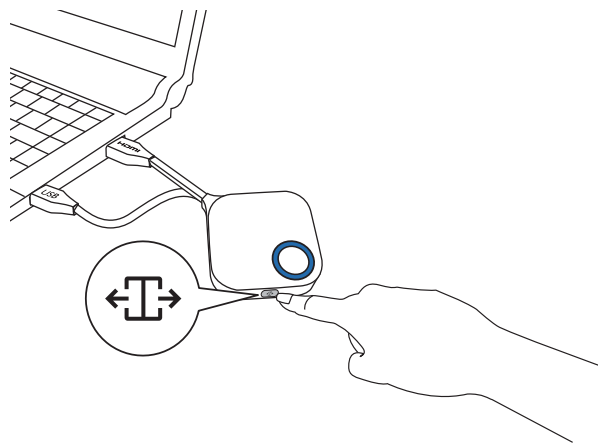

4. Once a notification appears on-screen indicating that the split screen function has been enabled, press the Present key on the Button of the second computer that wants to join the split screen presentation.
5. Repeat step 4 for all other users that want to join the split screen presentation.

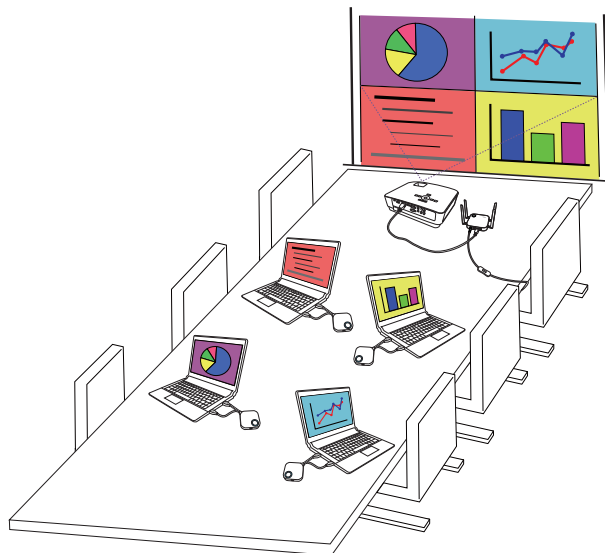

- Only up to 4 users are simultaneously supported in a split screen presentation.
- The layout of the split screen presentation will be dictated by the amount of users in the presentation.
- If split screen is not enabled by the initial Button, all subsequent connections by other Buttons will be full screen presentations.

Switching from a split screen to a full screen presentation

Once in a split screen presentation you can switch to a full screen presentation of any of the participant's screen by pressing the split screen button on the Button of the computer that wants to present in a full screen.

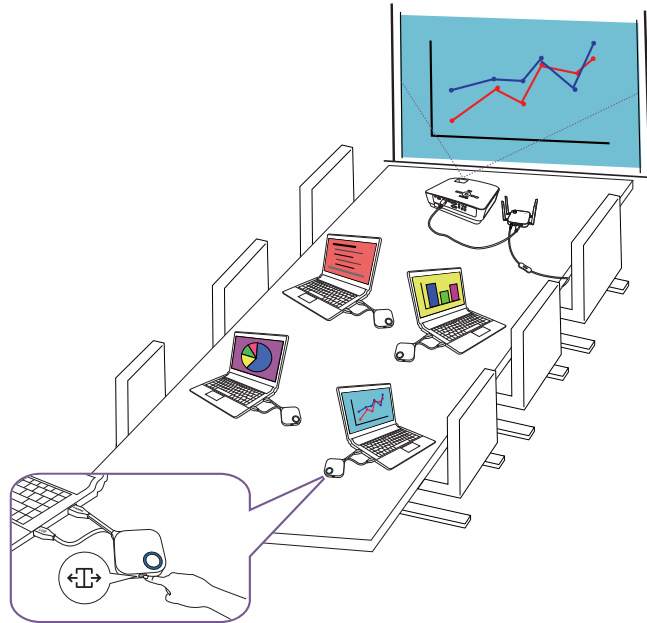

To return to a split screen presentation repeat the steps in [Starting a split screen presentation on page 28](#).

Presenting with mobile devices

Users with mobile devices can connect their mobile devices to the Host and make a presentation via the InstaShare app by following the steps below:

1. Install the InstaShare app on your mobile device using the QR code located on the guide screen.
2. In your mobile device's Wi-Fi menu, connect to the SSID indicated in the guide screen.
3. Use the InstaShare app to project your screen.

Controlling presentations

When a Host is connected to a touchscreen display and a PC is presenting via a Button, you can use a USB Type-A cable to connect any of the USB ports located at the rear of the Host to the touch input USB port of the display to control the interface of the PC remotely via touch gestures on the display.

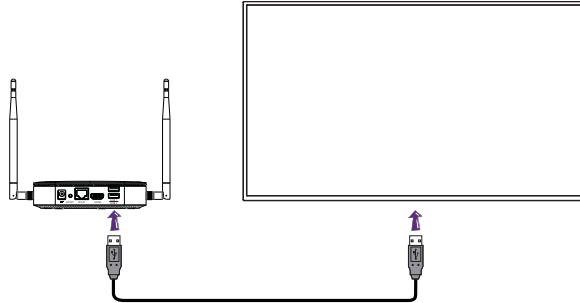

- The product only supports touch control for Windows-based PCs. The product does not support touch control for MacBooks or smartphones connected via the InstaShare app.

For presentations that do not feature a touchscreen display, you can connect a USB mouse and/or USB keyboard to any of the USB ports located at the rear of the Host to control the interface of the presenting computer and input text remotely via the mouse/keyboard.

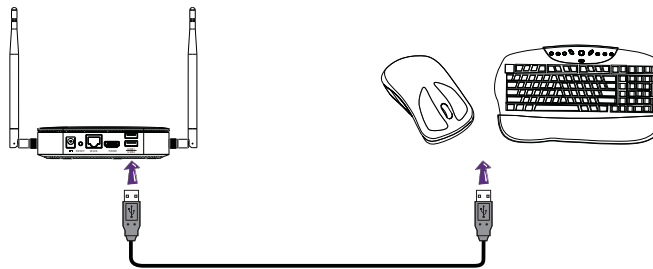

Troubleshooting

Category	Problem	Cause	Solution
Your screen	Your screen is not appearing on the display when pressing the Button.	The Button is connecting to another Host.	The Button should be paired again with the Host.
		Pressing time is not enough.	Press the Present key until the LED indicator turns from green to blue.
	The screen turns blank or flickers when the Host is presenting.	Insufficient power supply	Change power supply of the Host to a power adapter.
	The screen lags seriously and the audio breaks up sometimes.	Insufficient power supply for the Button. An laptop with USB 2.0 port may be used as the power supply for the Button.	Make sure you use USB 3.0 as the power supply for the Button.
		Wi-Fi interference or signal attenuation	<ul style="list-style-type: none"> • Make sure the transmission distance is within 15M and with no obstacles. • Restart the Host in order to rescan the Wi-Fi 5G channel.
Your screen	The message, "No Signal", from the Host is shown on the display when the Button is presenting, or your screen is blank gray.	The HDMI connection between your laptop and the Button is loose.	Reconnect the HDMI cable of the Button.
		Your laptop cannot detect the second monitor.	<ul style="list-style-type: none"> • Reconnect the USB cable of the Button. • Reboot your laptop.
	Your screen is shown, but your audio is not playing on the audio system of the meeting room.	The audio signal on your laptop is muted.	Right click on the speaker icon and switch off the mute.
		The audio output of the laptop hasn't been set to the second screen (BenQ InstaShow™ S) from the EDID of the Button.	Change the default audio output to the second screen (BenQ InstaShow™ S) on the laptop.

Category	Problem	Cause	Solution
The Button	Your content is removed from the display and the LED indicator of your Button is blinking red.	The wireless connection is lost between the Button and Host.	<ol style="list-style-type: none"> 1. The Host will restore the Wi-Fi connection automatically. 2. If this fails, the LED indicator of your Button starts blinking red. 3. Unplug the Button from your laptop and try again.
		Wi-Fi interference or signal attenuation	Make sure the transmission distance is within 15M and with no obstacles.
	The LED indicator of the Button is blinking red when the power is on.	The Host has not been turned on.	Make sure Host is turned on.
		The Host has not paired with a Button.	The Host should pair with the Button again.
		Wi-Fi interference or signal attenuation	Make sure the transmission distance is within 15M and with no obstacles.
	The LED indicator of the Button is always off.	There is no power supply.	Check the USB port of your laptop. If the port fails to function, try other USB ports.
The Button	The Button automatically restarts sometimes.	Insufficient power supply.	Make sure you use USB 3.0 as the power supply for the Button.
	The LED indicator on the Button remains static red even after it has been powered on for 30 seconds.	The Button has not been properly powered off during the resetting process	Reset the Button.
	The pairing function cannot be executed via the MODE key while the Button is powered on and the LED starts flashing red.		

Category	Problem	Cause	Solution
The Host	Nothing is shown on the display at all.	The display is switched off.	Switch on the display.
		The wrong input is selected.	Select the correct input.
		The display cable is not connected properly.	Insert the HDMI cable between the Host and the display device again.
		The display fails to show the Host's output resolution at 720p in "Guide Screen" or "Idle Screen".	Replace the display with a new one that supports output resolution at 720p.
		The Host is in Network Standby Mode when network standby function is enabled.	Press the Present key of the Button to start presentation.
The Host	Nothing is shown on the display at all.	The Host is in HDMI Standby Mode when HDMI standby function is enabled.	Briefly press the standby button on the Host or power on the display (connected to the Host with an HDMI cable). The Host will wake up automatically.
		The Host is powered off.	Briefly press the standby button on the Host.
		Insufficient power supply	Change power supply of Host to a power adapter.
	The LED indicator on the Host remains static red even after it has been powered on for 30 seconds.	The Host has not been properly powered off during the resetting process	Reset the Host.
EDID	After connecting the Button to your laptop, the second screen (InstaShow™ S) cannot be detected.	The HDMI connection between your laptop and the Button is loose.	Reconnect the HDMI cable of the Button.
		Laptop problem	Reboot your laptop.
		The Button is shutdown.	Reconnect the USB cable of the Button.

Category	Problem	Cause	Solution
Pairing	The message, "Pairing failed", from the Host is shown on the display when the Host is pairing with the Button.	Wi-Fi interference or signal attenuation	Make sure the transmission distance is within 15M and with no obstacles.
		The Button has not entered the pairing mode in time.	When the Host enters pairing mode, the Button should also enter pairing mode within two minutes.
Windows Software	When presenting a video file via Gom Media Player, the full-screen image is cut into upper and lower halves.	Media player	Use other media players to play video files, such as Windows Media Player.

Regulatory Statements

V1.1

CE DoC

DECLARATION OF CONFORMITY

English

The device complies with the requirements set out in the Council Directives relevant Union harmonisation legislation:

RED Directive (2014/53/EU)

RoHS Directive 2011/65/EU & (EU) 2015/863

Ecodesign Directive 2009/125/EC

Turkish ErP (Decision 2010/643)

Turkish EEE Directive

DÉCLARATION DE CONFORMITÉ

Français

L'appareil est conforme aux exigences définies dans les directives du Conseil relatives à la législation d'harmonisation de l'Union :

Directive RED (2014/53/UE)

Directive RoHS 2011/65/UE et (UE) 2015/863

Directive sur l'écoconception 2009/125/CE

ErP turque (décision 2010/643)

Directive EEE turque

DECLARACIÓN DE CONFORMIDAD

Español

El dispositivo cumple los requisitos impuestos en las directivas del Consejo relativas a la legislación de armonización de la Unión Europea:

Directiva sobre equipos radioeléctricos (2014/53/UE)

Directiva sobre sustancias peligrosas 2011/65/UE y (UE) 2015/863

Directiva sobre diseño ecológico 2009/125/CE

ErP de Turquía (Decisión 2010/643)

Directiva EEE de Turquía

DECLARAÇÃO DE CONFORMIDADE

Português

O dispositivo está conforme aos requisitos das Diretivas do Conselho e relevante legislação de harmonização da União Europeia:

Diretiva RED (2014/53/UE)

Diretiva RoHS 2011/65/UE & (UE) 2015/863

Diretiva Ecodesign 2009/125/CE

ErP Turca (Decisão 2010/643)

Diretiva EEE Turca

DICHIARAZIONE DI CONFORMITÀ

Italiano

Il dispositivo è conforme con i requisiti definiti nelle Direttive del Consiglio relative alla Norma sull'armonizzazione dell'Unione:

Direttiva RED (2014/53/UE)

Direttiva RoHS 2011/65/UE e (UE) 2015/863

Direttiva Ecodesign 2009/125/CE

ErP turca (Decisione 2010/643)

Direttiva EEE turca

KONFORMITÄTSERKLÄRUNG

Deutsch

Das Gerät entspricht den Anforderungen der entsprechenden EU-Harmonisierungsrichtlinien des Rates:
RED-Richtlinie (2014/53/EU)
RoHS-Richtlinie 2011/65/EU & (EU) 2015/863
Ökodesign-Richtlinie 2009/125/EG
Türkische ErP (Beschluss 2010/643)
Türkische EEE-Richtlinie

ЗАЯВЛЕНИЕ О СООТВЕТСТВИИ

Русский

Это устройство отвечает требованиям, изложенным в Директивах Совета о гармонизации соответствующих законов государств, входящих в состав Европейского союза (EU):
Директива о радиооборудовании (2014/53/EU)
Директива 2011/65/EU и (EU) 2015/863 об ограничении использования определенных видов опасных веществ в электрическом и электронном оборудовании (RoHS)
Директива 2009/125/EC, устанавливающая требования к экологическому проектированию продукции
Турецкая Директива по энергоэффективности (Решение 2010/643)
Турецкая Директива об электрическом и электронном оборудовании

Oświadczenie zgodności

Polski

Urządzenie jest zgodne z wymaganiami określonymi w odpowiednich unijnych Dyrektywach harmonizacyjnych Rady:
Dyrektywa RED (2014/53/UE)
Dyrektywa RoHS 2011/65/UE i (UE) 2015/863
Dyrektywa w sprawie ekoprojektu 2009/125/WE
Turecka dyrektywa ErP (decyzja 2010/643)
Turecka dyrektywa EEE

UYUM BEYANI

Türkçe

Aygıt, Konsey Yönergeleri ile ilgili Birlik uyum mevzuatında belirtilen şartlara uygundur:
RED Yönergesi (2014/53/EU)
RoHS Yönergesi 2011/65/EU & (EU) 2015/863
Eko-tasarım Yönergesi 2009/125/EC
Türkçe ErP (Karar 2010/643)
Türkçe EEE Yönergesi

OVERENSSTEMMELSESERKLÆRING

Dansk

Enheden er i overensstemmelse med kravene i Rådets direktiv, relevant til EU's lovgivning om harmonisering:
RED-direktiv (2014/53/EU)
RoHS-direktiv 2011/65/EU og (EU) 2015/863
Erp-direktiv 2009/125/EF
Tyrkisk ErP (beslutning 2010/643)
Tyrkisk EEE-direktiv

VAATIMUSTENMUKAISUUSVAKUUTUS

Suomi

Laite on Euroopan neuvoston direktiivien olennaisen unionin harmonisointilainsäädännön vaatimusten mukainen:
RED-direktiivi (2014/53/EU)
RoHS-direktiivi 2011/65/EU & (EU) 2015/863
Ecodesign-direktiivi 2009/125/EY
Turkin ErP (Päätös 2010/643)
Turkin EEE-direktiivi

SAMSVARSERKLÆRING

Norsk

Enheten overholder kravene i EU-rådets harmoniseringsdirektiver:

RED-direktiv (2014/53/EU)

RoHS-direktiv 2011/65/EU & (EU) 2015/863

Ecodesign-direktiv 2009/125/EC

Tyrkisk ErP (beslutning 2010/643)

Tyrkisk EEE-direktiv

KONFORMITETSDEKLARATION

Svenska

Enheten uppfyller kraven som anges i Rådets direktivs relevanta harmoniseringslagstiftning för Europeiska unionen:

RED-direktivet (2014/53/EU)

RoHS-direktiv 2011/65/EU & (EU) 2015/863

Direktivet om ekodesign 2009/125/EG

Turkiska ErP (beslut 2010/643)

Turkiska EEE-direktivet

DECLARAȚIE DE CONFORMITATE

Română

Dispozitivul respectă cerințele menționate în Directivele Consiliului și în legislația armonizată relevantă la nivelul Uniunii:

Directiva privind echipamentele radio (2014/53/UE)

Directiva RoHS 2011/65/UE și (UE) 2015/863

Directiva privind proiectarea ecologică 2009/125/CE

ErP Turcia (Decizia 2010/643)

Directiva privind echipamentele electrice și electronice pentru Turcia

PROHLÁŠENÍ O SHODĚ

Čeština

Zařízení odpovídá požadavkům stanoveným ve směrnících Rady podle příslušných harmonizačních právních předpisů Unie:

Směrnice o rádiových zařízeních (2014/53/EU)

Směrnice o RoHS 2011/65/EU a (EU) 2015/863

Směrnice o ekodesignu 2009/125/ES

Turecká ErP (rozhodnutí 2010/643)

Turecká směrnice EEE

VERKLARING VAN OVEREENSTEMMING

Nederlands

Het apparaat voldoet aan de vereisten van de relevante richtlijnen van de Raad met betrekking tot harmonisatiewetgeving in de Unie:

RED-richtlijn (2014/53/EU)

RoHS-richtlijn 2011/65/EU & (EU) 2015/863

Richtlijn inzake ecologisch ontwerp 2009/125/EG

Turkse ErP (Besluit 2010/643)

Turkse EEE-richtlijn

MEGFELELŐSÉGI NYILATKOZAT

Magyar

Az eszköz megfelel a Tanács irányelvek releváns uniós harmonizálási rendelkezései által felállított követelményeknek:

RED-irányelv (2014/53/EU)

2011/65/EU és (EU) 2015/863 RoHS-irányelv

2009/125/EK Ecodesign-irányelv

Török ErP (2010/643-es határozat)

Török EEE-irányelv

ДЕΚΛΑΡΑЦИЯ ЗА СЪОТВЕТСТВИЕ

Български

Устройството отговаря на изискванията на уместното законодателство на Съюза за хармонизация на директивите на Съвета:

RED директива (2014/53/EC)

RoHS директива 2011/65/EC & (EC) 2015/863

Директивата за екодизайн 2009/125/EO

ErP на Турция (Решение 2010/643)

EEE директива на Турция

DEKLARACIJA O USKLAĐENOSTI

Hrvatski

Ovaj uređaj sukladan je s odredbama postavljenim u direktivama Vijeća vezanim uz relevantne harmonizacijske zakone Unije:

RED Direktiva (2014/53/EU)

RoHS Direktiva 2011/65/EU & (EU) 2015/863

Direktiva o ekološkom dizajnu 2009/125/EZ

Turski ErP (Odluka 2010/643)

Turska EEE direktiva

ΔΗΛΩΣΗ ΣΥΜΜΟΡΦΩΣΗΣ

Ελληνικά

Η συσκευή συμμορφώνεται με τις απαιτήσεις που καθορίζονται στις Οδηγίες του Ευρωπαϊκού Συμβουλίου και σχετίζονται με τη νομοθεσία περί εναρμόνισης της Ένωσης:

Οδηγία περί RED (2014/53/EE)

Οδηγία περί RoHS 2011/65/EE & (EE) 2015/863

Οδηγία περί Ecodesign 2009/125/EK

Τουρκικό ErP (Απόφαση 2010/643)

Τουρκική Οδηγία περί EEE

For EU

Hereby, BenQ Corporation, declares that this WDC20 is in compliance with the essential requirements and other relevant provisions of Directive 2014/53/EU.

The full test of the EU declaration of conformity is available at the following internet address:

<https://www.benq.eu/en-eu/index.html>

This equipment should be installed and operated with a minimum distance of 20 centimeters between the radiator and your body

Hardware Version:

RKC180508_V1.02 (WDC20TH) ; RKG180424_A_V1.03&RKG180424_B_V1.01 (WDC20TH);

Software Version: WDC20(R)_1.00.20/1.2.8 (WDC20R) ; WDC20(T)_1.00.20 (WDC20TH) ;

Frequency band: 2.4G

	WDC20R
RF Output Power	2400 ~ 2483.5MHz 12 dBm

Frequency Band: 5G

	WDC20TH	WDC20R
RF Output Power & Transmit Power Control (TPC)	5.15 ~ 5.25GHz 10.82 dBm 5.25 ~ 5.35GHz 10.94 dBm 5.47 ~ 5.725GHz 10 dBm	5.15 ~ 5.25GHz 11.29 dBm 5.25 ~ 5.35GHz 12.1 dBm m 5.47 ~ 5.725GHz 10 dBm

RoHS Statement

This product is compliant to implemented RoHS (Restriction of Hazardous Substances) type regulations worldwide, including but not limited to China, India, Japan, Korea and European Union.

Turkey RoHS

EEE Yönetmeliğine Uygun Elektrikli Ve Elektronik Eşyalarda Bazı Zararlı Maddelerin Kullanımının Sınırlanmasına Dair Yönetmelik

Ukraine RoHS

України ТЕХНІЧНИЙ РЕГЛАМЕНТ обмеження використання деяких небезпечних речовин в електричному та електронному обладнанні (від 3 грудня 2008 р. N 1057): Обладнання відповідає вимогам Технічного регламенту обмеження використання деяких небезпечних речовин в електричному та електронному обладнанні

India RoHS

Restriction on Hazardous Substances statement (India)

This product complies with the "India" E-waste Rule 2016" and prohibits use of lead, mercury, hexavalent chromium, polybrominated biphenyls or PolyBrominated Diphenyl Ethers in concentrations exceeding 0.1 weight% and 0.01 weight for cadmium except for exemptions set in Schedule 2 of the Rule.

Vietnam RoHS

Công ty BenQ tuyên bố rằng tất cả các sản phẩm mang nhãn hiệu BenQ được thiết kế và sản xuất phù hợp với Thông tư 30/2011/TT-BCT của Việt Nam về việc hạn chế các chất độc hại và nồng độ tối đa của chất độc cho phép trong các vật liệu đồng nhất (ngoại trừ các trường hợp miễn trừ được liệt kê trong Thông tư này).

WEEE directive

WEEE directive

English



Disposal of Waste Electrical and Electronic Equipment and/or Battery by users in private households in the European Union.

WEEE

This symbol on the product or on the packaging indicates that this can not be disposed of as household waste. You must dispose of your waste equipment and/or battery by handling it over to the applicable take-back scheme for the recycling of electrical and electronic equipment and/or battery. For more information about recycling of this equipment and/or battery, please contact your city office, the shop where you purchased the equipment or your household waste disposal service. The recycling of materials will help to conserve natural resources and ensure that it is recycled in a manner that protects human health and environment.



Battery

Recycling information: See <http://www.benq.com/support/recycle> for details.

Directive DEEE

Français



Mise au rebut des déchets d'équipements électriques et électroniques et/ou des piles par les particuliers dans l'Union Européenne.

WEEE

Ce symbole figurant sur le produit ou l'emballage signifie que celui-ci ne peut pas être jeté avec les ordures ménagères. Vous devez mettre vos déchets d'équipements et/ou piles au rebut en le déposant dans un point de collecte prévu à cet effet afin que les équipements électroniques et électriques et/ou piles soient recyclés. Pour de plus amples informations sur le recyclage de ce produit et/ou cette pile, veuillez prendre contact avec l'organisme local compétent, le service d'élimination des déchets ménagers ou le point de vente du produit. Le recyclage des matériaux aidera à conserver les ressources naturelles et à s'assurer qu'ils seront recyclés d'une façon que cela protège la santé humaine et l'environnement.



Pile

Recycling information: See <http://www.benq.com/support/recycle> for details.



WEEE



Batería

Residuos de aparatos eléctricos y electrónicos y/o batería por parte de los usuarios domésticos privados en la Unión Europea.

El símbolo que muestra el producto o el embalaje indica que no puede ser desechado como residuo doméstico. Para desechar el equipo siga las directrices aplicables para el reciclaje de equipo eléctrico y electrónico y/o batería.

Para obtener más información sobre el reciclaje de este equipo y/o batería, póngase en contacto con el ayuntamiento, la tienda donde adquirió el equipo o el servicio de recogida de basuras. Al reciclar materiales ayudamos a conservar el medio natural y a garantizar el reciclaje de manera que proteja la salud y el medioambiente.

Recycling information: See <http://www.benq.com/support/recycle> for details.



WEEE



Batterie

Entsorgung von Elektro- und Elektronikgeräten bzw. Batterien in Privathaushalten der Europäischen Union.

Das Symbol auf der Produktverpackung zeigt an, dass dieses Gerät nicht mit dem normalen Hausmüll entsorgt werden darf. Sie sind verpflichtet, Ihre Altgeräte bzw. Batterien entsprechend der geltenden Bestimmungen für die Wiederverwertung von Elektro- und Elektronik-Altgeräten bzw. Batterien zu entsorgen. Weitere Informationen über das Recycling dieses Geräts bzw. Batterie erhalten Sie von Ihren örtlichen Behörden, Ihrem Fachhändler oder der lokalen Rücknahmestelle. Fachgerechtes Wertstoffrecycling spart nicht nur wertvolle Ressourcen, sondern schützt auch Umwelt und Gesundheit.

Recycling information: See <http://www.benq.com/support/recycle> for details.



WEEE



Batteria

Smaltimento di apparecchi elettrici ed elettronici e/o batterie nell'Unione Europea da parte di utenti privati.

Questo simbolo sul prodotto o sulla confezione indica che l'articolo non può essere smaltito come i normali rifiuti domestici. È necessario smaltire le apparecchiature e/o batterie secondo quanto previsto dagli schemi di recupero per il riciclaggio di apparecchiature elettriche e elettroniche e/o batterie. Per ulteriori informazioni sul riciclaggio di questo apparecchio e/o batteria, contattare l'ente della propria città, il negozio dove è stato acquistato l'apparecchio o il proprio servizio di smaltimento rifiuti domestici. Il riciclaggio dei materiali contribuisce a ridurre il consumo di risorse naturali e assicura che i materiali siano riciclati tutelando la salute umana e l'ambiente.

Recycling information: See <http://www.benq.com/support/recycle> for details.



WEEE



Аккумулятор

Утилизация электрического и электронного оборудования и/или аккумуляторов населением в Европейском союзе.

Данный символ на изделии или на упаковке означает, что данное изделие запрещается утилизировать наравне с бытовыми отходами. Вы должны сдавать все пришедшие в негодность устройства и/или аккумуляторы для утилизации на специальный пункт сбора электрических или электронных устройств и/или аккумуляторов. Для получения подробных сведений о переработке этого оборудования и/или аккумуляторов обратитесь в местные органы управления, магазин, в котором был приобретен продукт, или службу по сбору бытовых отходов. Переработка материалов поможет сохранить природные ресурсы и обеспечит безопасность для здоровья людей и окружающей среды.

Recycling information: See <http://www.benq.com/support/recycle> for details.



WEEE



Batteri

Riktlinjer för kassering av avfall som utgörs av eller innehåller elektriska eller elektroniska produkter och/eller batteri, gällande hushåll i EU.

Den här symbolen kan finnas på produkten eller på förpackningen och betyder att produkten inte kan kasseras som vanligt hushållsavfall. När du vill kassera produkten och/eller batteri måste du lämna in den på det ställe som avses för återvinning av elektriska eller elektroniska produkter och/eller batteri. Om du vill ha mer information om återvinning av den här typen av utrustning och/eller batteri kan du vända dig till din kommun, ditt inköpsställe eller till den lokala sophämtningen. Genom att återvinna materialet i produkten kan vi spara på naturtillgångarna och försäkra oss om att produkten återvinns på ett sätt som skyddar människors hälsa och miljön.

Recycling information: See <http://www.benq.com/support/recycle> for details.



WEEE



Accu

Wegwerpen van elektrische en elektronische apparatuur en/of accu's door huishoudens in de Europese Unie.

Dit symbool geeft aan dat het product niet met het huishoudelijke afval kan worden aangeboden. U moet afgedankte apparatuur en/of accu's wegwerpen door ze in te leveren op de inzamelpunten voor elektrische en elektronische apparatuur en/of accu's. Voor meer informatie over het hergebruik van deze apparatuur en/of de accu neemt u contact op met uw gemeente, de winkel waar u de apparatuur hebt gekocht of de milieudienst van de gemeente. Door het recyclen van de materialen worden natuurlijke hulpbronnen behouden en helpt u de natuur en de volksgezondheid te beschermen.

Recycling information: See <http://www.benq.com/support/recycle> for details.



WEEE



Bateria

Utylizacja odpadów z urządzeń elektrycznych i elektronicznych lub baterii przez użytkowników prywatnych w Unii Europejskiej.

Ten symbol na urządzeniu lub opakowaniu oznacza, że nie może być ono utylizowane razem z odpadami domowymi. Zużyty sprzęt lub baterie należy przekazać do odpowiedniego punktu zwrotu sprzętu elektrycznego i elektronicznego w celu wtórnego przetworzenia. Szczegółowe informacje dotyczące wtórnego przetwarzania tych urządzeń lub baterii można uzyskać, kontaktując się z lokalną administracją, sprzedawcą lub lokalnym przedsiębiorstwem oczyszczania. Przetwarzanie wtórne materiałów pomaga w zachowaniu surowców naturalnych i utylizacji w sposób przyjazny dla ludzkiego zdrowia i środowiska.

Recycling information: See <http://www.benq.com/support/recycle> for details.



WEEE



Baterie

Likvidace vyřazených elektrických a elektronických zařízení anebo baterií v domácnostech uživatelů v Evropské unii.

Tento symbol na výrobku nebo na jeho obalu znamená, že dané zařízení nelze vyhodit do běžného domovního odpadu. Vyřazené elektrické nebo elektronické zařízení anebo baterií je nutno zlikvidovat odevzdáním k recyklaci v souladu s platným plánem recyklace elektrických a elektronických zařízení anebo baterií. Další informace o recyklaci tohoto zařízení anebo baterií získáte u místních úřadů, v obchodě, kde jste výrobek zakoupili nebo u společnosti, která se zabývá likvidací domovního odpadu.

Recyklace materiálů pomáhá chránit přírodní zdroje a zaručuje likvidaci výrobku způsobem, který je šetrný k lidskému zdraví a životnímu prostředí.

Recycling information: See <http://www.benq.com/support/recycle> for details.



WEEE



Pil

Avrupa Birliği ülkelerinde özel ev eşyası kullanıcıları tarafından Elektrikli ve Elektronik Cihazların ve/veya Pillerin Atılması.

Ürün yada ambalaj üzerindeki bu sembol, bunun evsel atık olarak işlem görmemesi gerektiğini ifade etmektedir. Atık cihazınızı ve/veya pilleri, elektrikli ve elektronik cihazların ve/veya pillerin geri dönüşümü için uygulanabilir geri alma şemasına göre ele alarak atmalısınız. Bu cihazın ve/veya pillerin geri dönüşümü hakkında daha fazla bilgi edinmek için lütfen cihazı satın aldığınız yerel bayiye veya dükkana yada ev eşyası uzaklaştırma servisine başvurun. Materyallerin geri dönüşümü, doğal kaynakların korunmasını ve insan sağlığına ve çevreye zarar verilmeksizin geri dönüştürülmesini güvence etmektedir.

Recycling information: See <http://www.benq.com/support/recycle> for details.



WEEE



Bateria

Eliminação de Resíduos de Equipamentos Eléctricos e Electrónicos e/ou Baterias por particulares na União Europeia.

Este símbolo no produto ou na embalagem indica que não pode ser eliminado como lixo doméstico. Deverá eliminar os resíduos dos seus equipamentos e/ou baterias entregando-os nos pontos de recolha aplicáveis para reciclagem de equipamentos de equipamentos eléctricos e electrónicos e/ou baterias. Para mais informações sobre a reciclagem destes equipamentos e/ou baterias, contacte a sua câmara municipal, a loja onde adquiriu o equipamento ou serviço de recolha de lixo doméstico. A reciclagem de materiais contribuirá para a conservação dos recursos naturais e assegura que são reciclados de forma a proteger a saúde humana e o ambiente.

Recycling information: See <http://www.benq.com/support/recycle> for details.



WEEE



Akkumulátor

Az Európai Unióban a háztartások elektromos és elektronikus hulladékainak és/vagy az akkumulátorok kezeléséről szóló irányelv.

A terméken vagy a csomagoláson ez a szimbólum azt jelzi, azt aháztartásihulladékoktól külön kell kezelni. A készüléket és/vagy az akkumulátorokat az elektronikus és elektromos hulladékokra és/vagy az akkumulátorokra érvényes újrahasznosítási rendszer keretein belül kell leadni újrahasznosításra. A készülék és/vagy akkumulátorok újrahasznosítás céljára való begyűjtéséről bővebb információt kaphat a helyi önkormányzatnál, a vásárlás helyén vagy a háztartási hulladékot elszállító szolgáltatójánál. Az anyagok újrahasznosításra való begyűjtése hozzájárul a természeti erőforrások megőrzéséhez és biztosítja, hogy a hulladékok szelektálása az emberi egészséget és a környezetet védő módon történjék.

Recycling information: See <http://www.benq.com/support/recycle> for details.



WEEE



Батерия

Изхвърляне на отпадъчно електрическо и електронно оборудване и/или батерии от потребители в частни домакинства в Европейския съюз.

Този символ върху продукт или неговата опаковка указва, че не може да бъде изхвърлян заедно с останалите домакински отпадъци. Трябва да изхвърлите отпадъчното оборудване и/или батерии, като го предадете в подходящ пункт за събиране и рециклиране на електрическо и електронно оборудване и/или батерии. За повече информация относно рециклирането на този уред и/или батерии, моля, свържете се със съответния офис във Вашия град, с магазина, от който сте закупили продукта или с местната служба за събиране на битови отпадъци. Рециклирането на материалите ще спомогне за запазване на природните ресурси и ще осигури рециклиране по запазващ човешкото здраве и околната среда начин.

Recycling information: See <http://www.benq.com/support/recycle> for details.



WEEE



Baterija

Odlaganje u otpad električnih i elektroničkih uređaja i/ili baterija iz kućanstava u Europskoj uniji.

Ovaj simbol na proizvodu ili pakiranju naznačuje da se ovaj proizvod ne može odbaciti s kućnim otpadom. Uređaje za otpad i/ili baterije trebate odložiti u otpad u skladu s pravilima povrata, zbrinjavanja i reciklaže električnih i elektroničkih uređaja i/ili baterija. Više informacija o recikliranju ovog uređaja i/ili baterije, potražite u vašem mjesnom uredu, u trgovini gdje ste kupili proizvod ili u službi koja prikuplja vaš kućni otpad. Recikliranje materijala pomoći će očuvanju prirodnih resursa i osigurati recikliranje na način koji štiti ljudsko zdravlje i prirodni okoliš.

Recycling information: See <http://www.benq.com/support/recycle> for details.



WEEE



Baterie

Evacuarea deșeurilor echipamentelor electrice și electronice și/sau bateriilor de către utilizatorii casnici din Uniunea Europeană.

Acest simbol de pe produs sau de pe ambalaj indică că acest produs nupoate fi evacuat ca deșeu casnic. Trebuie să evacuați deșeurile de echipamente și/sau bateria prin predarea conform schemei de preluare pentru reciclare a componentelor electrice și electronice și/sau a bateriilor. Pentru informații suplimentare privind reciclarea acestui echipament și/sau a bateriei, contactați primăria orașului dvs., magazinul de unde ați achiziționat echipamentul sau serviciul de salubritate pentru deșeuri menajere. Reciclarea acestor materiale va ajuta la păstrarea resurselor naturale și asigură că sunt reciclate într-o modalitate care protejează viața și mediul oamenilor.

Recycling information: See <http://www.benq.com/support/recycle> for details.



WEEE



Μπαταρία

Απόρριψη άχρηστου ηλεκτρολογικού και ηλεκτρονικού εξοπλισμού ή/και μπαταριών από χρήστες σε νοικοκυριά εντός της Ευρωπαϊκής Ένωσης.

Το παρόν σύμβολο στο προϊόν ή τη συσκευασία υποδηλώνει ότι αυτό δεν μπορεί να απορριφθεί με τα οικιακά απορρίμματα. Πρέπει να φροντίζετε για την απόρριψη του άχρηστου εξοπλισμού σας ή/και μπαταριών, παραδίδοντάς τα σε αρμόδιο φορέα παραλαβής με σκοπό την ανακύκλωση ηλεκτρολογικού και ηλεκτρονικού εξοπλισμού ή/και μπαταριών. Για περισσότερες πληροφορίες σχετικά με την ανακύκλωση του παρόντος εξοπλισμού ή/και μπαταριών, παρακαλούμε απευθυνθείτε στο αρμόδιο γραφείο του δήμου, στο κατάστημα όπου αγοράσατε τον εξοπλισμό ή στην υπηρεσία αποκομιδής οικιακών απορριμμάτων. Η ανακύκλωση των υλικών θα βοηθήσει την εξοικονόμηση φυσικών πόρων και θα διασφαλίσει ότι αυτά ανακυκλώνονται με τρόπο που προστατεύει την ανθρώπινη υγεία και το περιβάλλον.

Recycling information: See <http://www.benq.com/support/recycle> for details.



WEEE



Batteri

Bortskaffelse af elektrisk og elektronisk affald og/eller batterier, anvendt i husholdningen i EU.

Dette symbol på produktet eller på emballagen angiver, at det ikke kan bortskaffes som husholdningsaffald. Du skal bortskaffe affald (udstyr) og/eller batterier ved at levere det/dem til relevante genbrugscentre for elektrisk og elektronisk udstyr og/eller batterier. For yderligere oplysninger om genbrug af dette udstyr og/eller batterier skal du kontakte kommunen, butikken hvor du købte udstyret eller dit affaldsselskab. Genbrugsmaterialer hjælper med at bevare naturlige ressourcer og sikre, at det genbruges på en måde, der beskytter sundheden og miljøet.

Oplysninger om genbrug: Se <http://www.benq.com/support/recycle> for yderligere oplysninger.



WEEE



Akku

Sähkö- ja elektroniikkaromun ja/tai akkujen hävittäminen yksityisissä kotitalouksissa Euroopan unionin alueella.

Tämä merkintä tuotteessa tai sen pakkauksessa osoittaa, että tuotetta ei voida hävittää kotitalousjätteenä. Romulaitteet ja/tai akut tulee hävittää viemällä ne erilliskeräyspaikkaan sähkö- ja elektroniikkaromun ja/tai akkujen kierrätystä varten. Saat lisätietoja tämän laitteen ja/tai akun kierrättämisestä ottamalla yhteyttä alueesi jätehuoltoon, kotitalousjätteen kierrätyskeskukseen tai laitteen ostopaikkaan. Materiaalien kierrätys auttaa säilyttämään luonnonvaroja ja varmistamaan, että jätteet kierrätetään tavalla, joka suojelee ihmisten terveyttä ja ympäristöä.

Kierrätystiedot: Lisätietoja <http://www.benq.com/support/recycle>.

WEEE-direktiv

Norwegian



WEEE



Batteri

Kassering av elektrisk og elektronisk utstyr og/eller batterier for brukere i private husholdninger i EU.

Dette symbolet på produktet eller på innpakningen angir at det ikke kan kasseres sammen med vanlig husholdningsavfall. Du må kaste utstyret og/eller batteriet ved å overlevere det til det aktuelle retursenteret for resirkulering av elektrisk og elektronisk utstyr og/eller batteriet. Hvis du vil ha mer informasjon om resirkulering og/eller batteriet, vennligst kontakt lokale myndigheter, butikken der du kjøpte utstyret eller en resirkuleringsstasjon. Resirkulering av materialer vil bidra til å bevare naturlige ressurser og sikre at det resirkuleres på en måte som beskytter menneskers helse og miljø.

Resirkuleringsinformasjon: Se <http://www.benq.com/support/recycle> hvis du vil ha detaljer.

FCC statement (for the United States only)

Federal Communication Commission Interference Statement

This equipment has been tested and found to comply with the limits for a Class B digital device, pursuant to Part 15 of the FCC Rules. These limits are designed to provide reasonable protection against harmful interference in a residential installation. This equipment generates, uses and can radiate radio frequency energy and, if not installed and used in accordance with the instructions, may cause harmful interference to radio communications. However, there is no guarantee that interference will not occur in a particular installation. If this equipment does cause harmful interference to radio or television reception, which can be determined by turning the equipment off and on, the user is encouraged to try to correct the interference by one of the following measures:

- Reorient or relocate the receiving antenna.
- Increase the separation between the equipment and receiver.
- Connect the equipment into an outlet on a circuit different from that to which the receiver is connected.
- Consult the dealer or an experienced radio/TV technician for help.

This device complies with Part 15 of the FCC Rules. Operation is subject to the following two conditions: (1) This device may not cause harmful interference, and (2) *this device must accept any interference received, including interference that may cause undesired operation.*

FCC Caution: Any changes or modifications not expressly approved by the party responsible for compliance could void the user's authority to operate this equipment.

FCC RF exposure information (SAR)

Radiation Exposure Statement	
Model Name: WDC20TH FCC ID:JVPWDC20TH	SAR compliance has been established in typical laptop computer(s) with USB slot, and product could be used in typical laptop computer with USB slot. Other application like handheld PC or similar device has not been verified and may not compliance with related RF exposure rule and such use shall be prohibited.
Model Name: WDC20R FCC ID:JVPWDC20R	This equipment should be installed and operated with minimum distance 20cm between the radiator & your body.

Caution:

(i) the device for operation in the band 5150 - 5250 MHz is only for indoor use to reduce the potential for harmful interference to co-channel mobile satellite systems; (ii) the maximum antenna gain permitted for devices in the bands 5250 - 5350 MHz and 5470 - 5725 MHz shall comply with the e.i.r.p. limit.

(iv) Users should also be advised that high-power radars are allocated as primary users (i.e. priority users) of the bands 5250 - 5350 MHz and 5650 - 5850 MHz and that these radars could cause interference and/or damage to LE-LAN devices.

FCC SDoC: Visit www.benq.com/en-us the purchased model > the **Support** tab > the **User Manual** tab to access the SDoC (Supplier's Declaration of Conformity) document. You may not find your product's SDoC document online as it was not required at the time the product was manufactured. However, it does not change the fact that the product has been tested to comply with FCC standards, as indicated by the FCC logo on the product or on the label.

IC statement (for Canadian users)

This Class B digital apparatus complies with Canadian ICES-3 (B).

Cet appareil numérique de la classe A est conforme à la norme NMB-3(B) du Canada.

This device complies with Industry Canada license-exempt RSS standard(s). Operation is subject to the following two conditions: (1) this device may not cause interference, and (2) this device must accept any interference, including interference that may cause undesired operation of the device.

Le présent appareil est conforme aux CNR d'Industrie Canada applicables aux appareils radio exempts de licence.

L'exploitation est autorisée aux deux conditions suivantes: (1) l'appareil ne doit pas produire de brouillage, et (2) l'utilisateur de l'appareil doit accepter tout brouillage radioélectrique subi, même si le brouillage est susceptible d'en compromettre le fonctionnement.

IMPORTANT NOTE:

Radiation Exposure Statement	
Model Name: WDC20TH IC: 6175A-WDC20TH	This equipment should be installed and operated with minimum distance 20cm between the radiator & your body. Cet équipement doit être installé et utilisé à distance minimum de 20cm entre le radiateur et votre corps.
Model Name: WDC20R IC: 6175A-WDC20R	This equipment should be installed and operated with minimum distance 20cm between the radiator & your body. Cet équipement doit être installé et utilisé à distance minimum de 20cm entre le radiateur et votre corps.

This radio transmitter (IC: 6175A-WDC20TH) has been approved by Industry Canada to operate with the antenna types listed below with the maximum permissible gain indicated. Antenna types not included in this list, having a gain greater than the maximum gain indicated for that type, are strictly prohibited for use with this device.

Le présent émetteur radio (IC: 6175A-WDC20TH) a été approuvé par Industrie Canada pour fonctionner avec les types d'antenne énumérés ci-dessous et ayant un gain admissible maximal. Les types d'antenne non inclus dans cette liste, et dont le gain est supérieur au gain maximal indiqué, sont strictement interdits pour l'exploitation de l'émetteur.

(WDC20R)

Type	Manufacture	Gain	Connector
Dipole	Shenzhen Lejin radio frequency technology Co., LTD	>3dBi	IPX-I

(WDC20TH)

Type	Manufacture	Gain	Connector
FPCB	Shenzhen Lejin radio frequency technology Co., LTD	>2dBi	SMT

The device for operation in the band 5150-5250MHz is only for indoor use.

Le dispositif destiné à être utilisé dans la bande 5150-5250 MHz est réservé à une.

This equipment should be installed and operated with a minimum distance of 20 centimeters between the radiator and your body.

Cet équipement doit être installé et utilisé avec une distance minimale de 20 centimètres entre le radiateur et votre corps.

The maximum antenna gain permitted for devices in the bands 5250-5350 MHz and 5470-5725 MHz shall be such that the equipment still complies with the e.i.r.p. limit;

le gain maximal d'antenne permis pour les dispositifs utilisant les bandes de 5250 à 5 350 MHz et de 5470 à 5725 MHz doit être conforme à la limite de la p.i.r.e;

The maximum antenna gain permitted for devices in the band 5725-5850 MHz shall be such that the equipment still complies with the e.i.r.p. limits specified for point-to-point and non-point-to-point operation as appropriate

le gain maximal d'antenne permis (pour les dispositifs utilisant la bande de 5 725 à 5 850 MHz) doit être conforme à la limite de la p.i.r.e. spécifiée pour l'exploitation point à point et l'exploitation non point à point, selon le cas

Exposure of humans to RF fields (RSS-102)

The computers employ low gain integral antennas that do not emit RF field in excess of Health Canada limits for the general population; consult Safety Code 6, obtainable from Health Canada's Web site at <http://www.hc-sc.gc.ca/>

The radiated energy from the antennas connected to the wireless adapters conforms to the IC limit of the RF exposure requirement regarding IC RSS-102, Issue 5 clause 4. SAR tests are conducted using recommended operating positions accepted by the FCC/ RSS with the device transmitting at its highest certified power level in all tested frequency band without distance attaching away from the body. Non-compliance with the above restrictions may result in violation of FCC RF exposure guidelines.

Conformité des appareils de radiocommunication aux limites d'exposition humaine aux radiofréquences (CNR-102)

L'ordinateur utilise des antennes intégrales à faible gain qui n'émettent pas un champ électromagnétique supérieur aux normes imposées par Santé Canada pour la population. Consultez le Code de sécurité 6 sur le site Internet de Santé Canada à l'adresse suivante : <http://www.hc-sc.gc.ca/> L'énergie émise par les antennes reliées aux cartes sans fil respecte la limite d'exposition aux radiofréquences telle que définie par Industrie Canada dans la clause 4.1 du document CNR-102, version 5. Tests DAS sont effectués en utilisant les positions recommandées par la FCC/CNR avec le téléphone émet à la puissance certifiée maximale dans toutes les bandes de fréquences testées sans distance attacher loin du corps. Non-respect des restrictions ci-dessus peut entraîner une violation des directives de la FCC/CNR.

日本専用です

VCCI (CLASS B)

この装置は、クラスB情報技術装置です。この装置は、家庭環境で使用することを目的としていますが、この装置がラジオやテレビジョン受信機に近接して使用されると、受信障害を引き起こすことがあります。

取扱説明書に従って正しい取り扱いをしてください。

この装置は、現在設置されている場所で妨害波の測定がされた情報技術装置であり、VCCI 協会の基準に適合しています。

従って、現在設置されている場所以外で使用する場合は、再び妨害波を測定し、VCCI に届け出をしなければなりません。

(RF モジュール付きの製品の場合)

電波法により 5GHz 帯は屋内使用に限ります。