

FCC TEST REPORT

for

47 CFR Part 24E

Equipment : **Mobile Phone**

Model No. : **M100 (56F52)**

FCC ID : **JVPM100**

Filing Type : **Certification**

Applicant : **BENQ Corporation**
157 Shan-Ying Road, Gueishan, Taoyuan 333,
Taiwan, R.O.C.

- The test result refers exclusively to the test presented test model / sample.
- Without written approval of SPORTON International Inc., the test report shall not be reproduced except in full.
- **Certificate or Test Report must not be used by the applicant to claim the product in this test report endorsement by NVLAP or any agency of U.S. government.**

SPORTON International Inc.

6F, No.106, Sec. 1, Hsin Tai Wu Rd., Hsi Chih, Taipei Hsien, Taiwan, R.O.C.

The applicant has been cautioned as to the following:

15.21 Information to User.

The users manual or instruction manual for an intentional radiator shall caution the user that changes or modifications not expressly approved by the party responsible for compliance could void the user's authority to operate the equipment.

15.27(a) Special Accessories.

Equipment marketed to a consumer must be capable of complying with the necessary regulations in the configuration in which the equipment is marketed. Where special accessories, such as shielded cables and/or special connectors are required to enable an unintentional or intentional radiator to comply with the emission limits in this part, the equipment must be marketed with, i.e. shipped and sold with, those special accessories. However, in lieu of shipping or packaging the special accessories with the unintentional or intentional radiator, the responsible party may employ other methods of ensuring that the special accessories are provided to the consumer, without additional charge.

Information detailing any alternative method used to supply the special accessories for a grant of equipment authorization or retained in the verification records, as appropriate. The party responsible for the equipment, as detailed in § 2.909 of this chapter, shall ensure that these special accessories are provided with the equipment. The instruction manual for such devices shall include appropriate instructions on the first page of text concerned with the installation of the device that these special accessories must be used with the device. It is the responsibility of the user to use the needed special accessories supplied with the equipment.

Table of Contents

Rule	Description	Page
	Test Report	4
2.1033(c)	General Information Required	5
2.1033(c)(14)	Rule Summary	9
	General Information	10
	Standard Test Conditions and Engineering Practices	11
2.1046(a)	EIRP Carrier Power (Radiated)	12
2.1051, 2.1049(c), 24, 24.238(b)	Transmitter Conducted Measurements	17
2.1053(a)	Field Strength of Spurious Radiation	23
2.1055(a)(1)	Frequency Stability (Temperature Variation)	43
2.1055(b)(1)	Frequency Stability (Voltage Variation)	46
	Antenna Factor & Cable Loss	43
	List of Measuring Equipments	44
	Uncertainty of Test Site	46
Appendix A	External Product Photograph	
Appendix B	Internal Photograph	
Appendix C	Set up Photograph	

Required information per ISO/IEC Guide 25-1990, paragraph 13.2:

a) **Test Report**

b) Laboratory: Sporton International Inc.
No.52, Hwa-Ya 1st RD., Hwa Ya Technology Park, Kwei-Shan
Hsiang, TaoYuan Hsien, Taiwan, R.O.C.

c) Report Number: F461002

d) Client: BENQ Corporation
157 Shan-Ying Road, Gueishan, Taoyuan 333, Taiwan, R.O.C.

e) Identification: Model Name: M100 (56F52)
FCC ID : JVPM100
Description: GSM 1900 Radio

f) EUT Condition: Not required unless specified in individual tests.

g) Report Date: June 21, 2004
EUT Received: June 10, 2004

h, j, k): As indicated in individual tests.

i) Sampling method: No sampling procedure used.

l) Uncertainty: In accordance with Sporton internal quality manual.

m) Supervised by:

Hendry Yang

n) Results: The results presented in this report relate only to the item tested.

o) Reproduction: This report must not be reproduced, except in full, without written permission from this laboratory.

Accessories Used During Testing:

Type	Model
EUT	M100 (56F52)
Earpiece	N/A

List of General Information Required for Certification

In Accordance with FCC Rules and Regulations,
Volume II, Part 2 and
24E, Confidentiality

Sub-Part 2.1033

(c)(1): Name and Address of Applicant:

BENQ Corporation
157 Shan-Ying Road, Gueishan, Taoyuan 333,
Taiwan, R.O.C.

Manufacturer

BENQ Corporation
157 Shan-Ying Road, Gueishan, Taoyuan 333,
Taiwan, R.O.C.

(c)(2): FCC ID: JVPM100

Model Number: M100 (56F52)

(c)(3): Instruction Manual(s):

Please See Attached Exhibits

(c)(4): Type of Emission: 300 KGXW

(c)(5): FREQUENCY RANGE, MHz: 1850.2 to 1909.8

(c)(6): Power Rating, Watts: 1.023(conducted)
0.550 (EIRP)
x Switchable Variable N/A

(c)(7): Maximum Power Rating, Watts: 1

Subpart 2.1033 (continued)

(c)(8): Voltages & Currents in All Elements in Final RF Stage, Including Final Transistor or Solid State Device:

Collector Current, A = 0.5
Collector Voltage, Vdc = 3.6
Supply Voltage, Vdc = 3.6

(c)(9): **Tune-Up Procedure:**

Please See Attached Exhibits

(c)(10): **Circuit Diagram/Circuit Description:**

Please See Attached Exhibits

(c)(11): **Label Information:**

Please See Attached Exhibits

(c)(12): **Photographs:**

Please See Attached Exhibits

(c)(13): **Digital Modulation Description:**

Attached Exhibits
 N/A

(c)(14): **Test and Measurement Data:**

Follows

**Testimonial
and
Statement of Certification**

This is to certify that:

1. **That** the application was prepared either by, or under the direct supervision of, the undersigned.
2. **That** the technical data supplied with the application was taken under my direction and supervision.
3. **That** the data was obtained on representative units, randomly selected.
4. **That**, to the best of my knowledge and belief, the facts set forth in the application and accompanying technical data are true and correct.

Certified by:

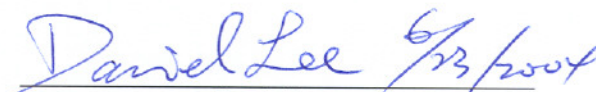

Daniel Lee
Manager

Certificate of NVLAP Accreditation

United States Department of Commerce
National Institute of Standards and Technology

NVLAP[®]

Certificate of Accreditation

ISO/IEC 17025:1999
ISO 9002:1994

SPORTON INTERNATIONAL, INC.
TAIPEI HSIEN 221
TAIWAN

*is recognized by the National Voluntary Laboratory Accreditation Program
for satisfactory compliance with criteria set forth in NIST Handbook 150:2001,
all requirements of ISO/IEC 17025:1999, and relevant requirements of ISO 9002:1994.
Accreditation is awarded for specific services, listed on the Scope of Accreditation, for:*

ELECTROMAGNETIC COMPATIBILITY AND TELECOMMUNICATIONS

December 31, 2004

Effective through

For the National Institute of Standards and Technology
NVLAP Lab Code: 200079-0



NVLAP-01C (06-01)

Sub-part

2.1033(c)(14): Test and Measurement Data

All tests and measurement data shown were performed in accordance with FCC Rules and Regulations, Volume II; Part 2, Sub-part J, Sections 2.947, 2.1033(c), 2.1041, 2.1046, 2.1047, 2.1079, 2.1051, 2.1053, 2.1055, 2.1057 and the following individual Parts:

- 22 – Public Mobile Services
- 22 Subpart H - Cellular Radiotelephone Service
- x 24 – Personal Communications Services

General Information

Product Feature & Specification	
1. Type of Modulation	GMSK
2. Number of Channels	GSM 1900 : 512 to 810
3. Frequency Band , MHz	Tx:: 1850-1910 Rx: 1805-1880
4. Channel Spacing	200 KHz
5. Maximum Output Power to Antenna	30.1 dBm
6. HW Version	LPR3
7. SW Version	0.15
8. Antenna Type	Fixed Internal Antenna

**Standard Test Conditions
and
Engineering Practices**

Except as noted herein, the following conditions and procedures were observed during the testing:

In accordance with TIA603, and unless otherwise indicated in the specific measurement results, the ambient temperature of the actual EUT was maintained within the range of 10° to 40°C (50° to 104 °F) unless the particular equipment requirements specify testing over a different temperature range. Also, unless otherwise indicated, the humidity levels were in the range of 10% to 90% relative humidity.

Prior to testing, the EUT was tuned up in accordance with the manufacturer's alignment procedures. All external gain controls were maintained at the position of maximum and/or optimum gain throughout the testing.

Measurement results, unless otherwise noted, are worst-case measurements.

Name of Test: EIRP Carrier Power (Radiated)

Specification: TIA/EIA 603A (Substitution Method)

Definition: The average radiated power of device is the equivalent power required, when delivered to a substitution antenna, to produce at a distant point the same average received power as produced by the licensed device.

Method Of Measurement:

a) Connect the equipment as illustrated. Place the transmitter to be tested on the turntable in the standard test site.

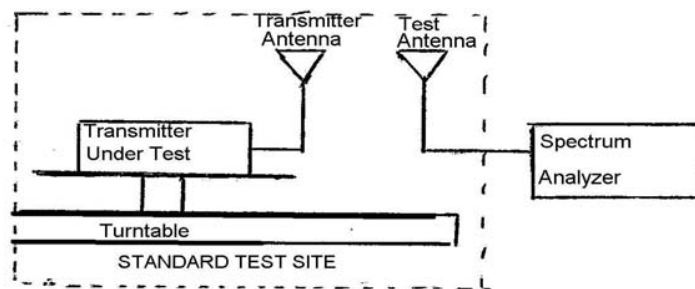

b) Raise and lower the test antenna from 1m to 4m and rotate turntable from 0° to 360°. Record the highest received signal showed in spectrum analyzer as R_t . Calculate electric field strength in receive antenna as E_t .

$$E_t = R_t + AF$$

AF (dB/m): Receive Antenna Factor

c) Replace the transmitter under test with a substitution antenna. The center of the antenna should be at the same location as the transmitter under test. Connect the antenna to a signal generator with a known output power level P_s . Raise and lower the test antenna like in step b) and record the highest received signal showed in spectrum analyzer as R_s . Calculate electric field strength in receive antenna as E_s .

$$E_s = R_s + AF$$

AF (dB/m): Receive Antenna Factor

d) Calculate radiated power as following:

$$EIRP = P_s + E_t - E_s + G_s$$

P_s (dBm): Input Power to Substitution Antenna

G_s (dBi) : Substitution Antenna Gain

Results Attached

Tim Kao

Tested By:

Tim Kao

Test Results For: EIRP Carrier Power (Radiated)

Conducted Power

Bands	Channel	Frequency (MHz)	Conducted Power (dBm)	Conducted Power (Watts)
GSM 1900	512	1850.2 (Low)	29.2	0.832
	661	1880.0 (Mid)	29.7	0.933
	810	1909.8 (High)	30.1	1.023

EIRP

Freq MHz	Pol	Substitution Antenna Input Power (dBm)	Substitution Antenna Gain (dBi)	Et (dBuV/m)	Es (dBuV/m)	Et - Es (dB)	Radiated Power (dBm)	Radiated Power (Watts)
1850.27	H	-3.76	6.64	126.22	101.70	24.52	27.41	0.550
1880.07	H	-3.78	6.65	126.03	101.64	24.39	27.26	0.532
1909.87	H	-3.81	6.66	123.60	101.58	22.02	24.87	0.307
1850.15	V	-3.76	6.64	124.45	101.70	22.75	25.64	0.366
1879.90	V	-3.78	6.65	122.63	101.64	20.99	23.86	0.243
1909.83	V	-3.81	6.66	121.79	101.58	20.21	23.06	0.203

GSM 1900 CH512 Horizontal Polarization

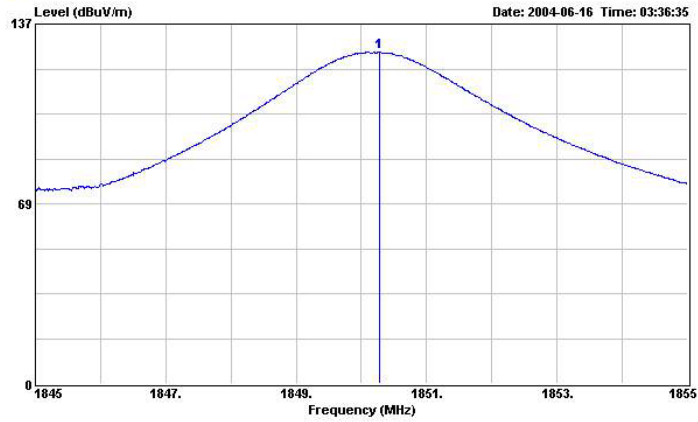

Site : 03CH03-HY
 Condition : 3m HORN-ANT-6821 HORIZONTAL
 EUT : Tri Band 900/1800/1900 Handset
 Model : M100
 Power : 120Vac/60Hz
 Memo : PCS 1900MHz CH512

Freq	Level	Over	Limit	Read	Probe	Cable	Preamp	Remark	Ant	Table
MHz	dBuV/m	dB	dBuV/m	dBuV	dB	dB	dB		cm	deg
1 1850.270	126.22	-----	-----	98.04	26.53	1.65	0.00	Peak	---	---

GSM 1900 CH512 Vertical Polarization

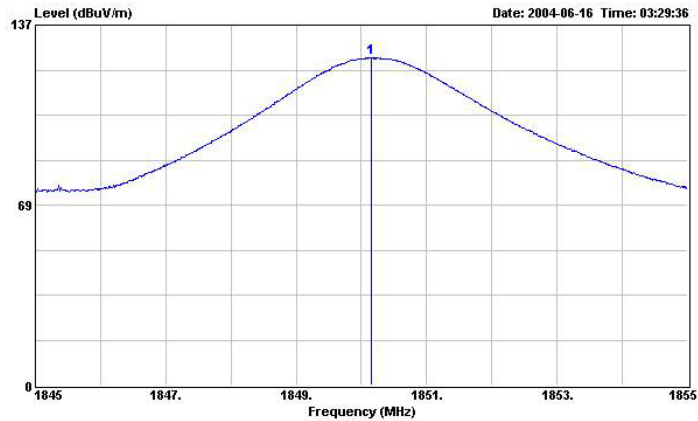

Site : 03CH03-HY
 Condition : 3m HORN-ANT-6821 VERTICAL
 EUT : Tri Band 900/1800/1900 Handset
 Model : M100
 Power : 120Vac/60Hz
 Memo : PCS 1900MHz CH512

Freq	Level	Over	Limit	Read	Probe	Cable	Preamp	Remark	Ant	Table
MHz	dBuV/m	dB	dBuV/m	dBuV	dB	dB	dB		cm	deg
1 1850.150	124.45	-----	-----	96.27	26.53	1.65	0.00	Peak	---	---

GSM 1900 CH661 Horizontal Polarization

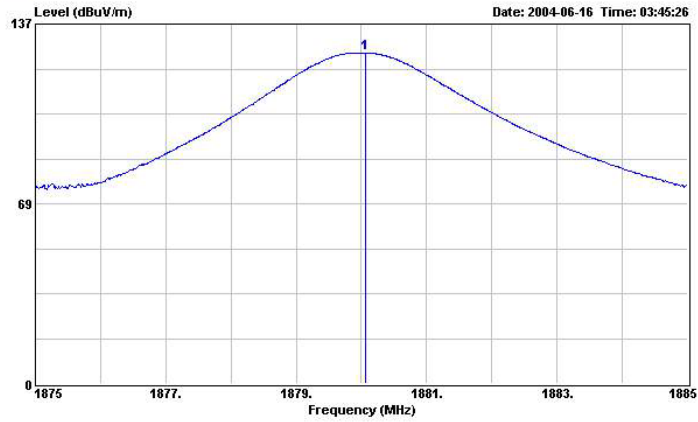

Site : 03CH03-HY
 Condition : 3m HORN-ANT-6821 HORIZONTAL
 EUT : Tri Band 900/1800/1900 Handset
 Model : M100
 Power : 120Vac/60Hz
 Memo : PCS 1900MHz CH661

Freq	Level	Over	Limit	Read	Probe	Cable	Preamp	Remark	Ant	Table
MHz	dBuV/m	dB	dBuV/m	dBuV	dB	dB	dB		cm	deg
1 1880.070	126.03	-----	-----	97.78	26.66	1.59	0.00	Peak	---	---

GSM 1900 CH661 Vertical Polarization

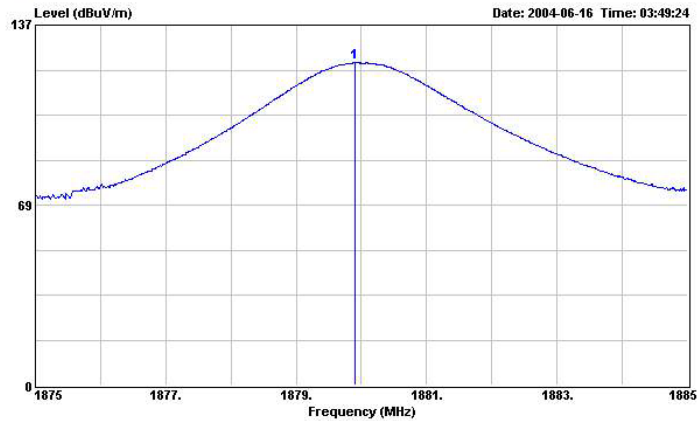

Site : 03CH03-HY
 Condition : 3m HORN-ANT-6821 VERTICAL
 EUT : Tri Band 900/1800/1900 Handset
 Model : M100
 Power : 120Vac/60Hz
 Memo : PCS 1900MHz CH661

Freq	Level	Over	Limit	Read	Probe	Cable	Preamp	Remark	Ant	Table
MHz	dBuV/m	dB	dBuV/m	dBuV	dB	dB	dB		cm	deg
1 1879.900	122.63	-----	-----	94.38	26.66	1.59	0.00	Peak	---	---

GSM 1900 CH810 Horizontal Polarization

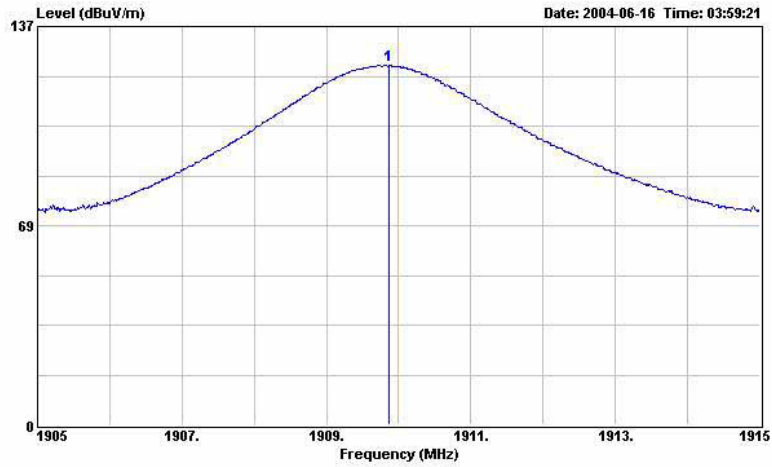

Site : 03CH03-HY
 Condition : 3m HORN-ANT-6821 HORIZONTAL
 EUT : Tri Band 900/1800/1900 Handset
 Model : M100
 Power : 120Vac/60Hz
 Memo : PCS 1900MHz CH810

1	1909.870	123.60	-----	-----	95.23	26.78	1.59	0.00	Peak	---	---
MHz	dBuV/m	dB	dBuV/m	dBuV	dB	dB	dB	dB	cm	deg	

GSM 1900 CH810 Vertical Polarization

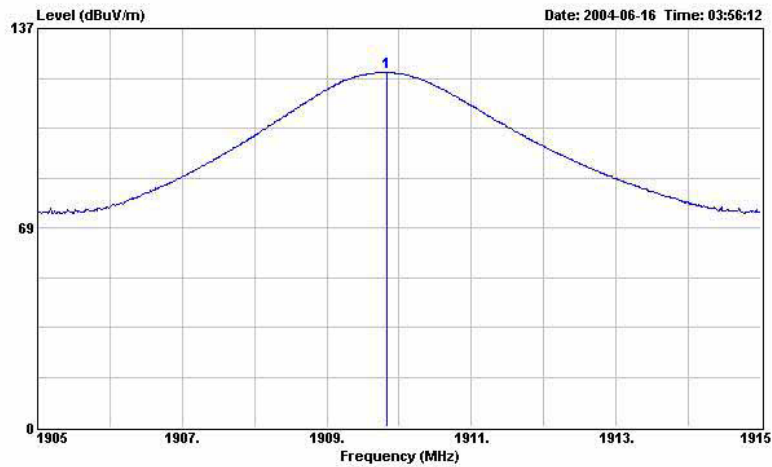

Site : 03CH03-HY
 Condition : 3m HORN-ANT-6821 VERTICAL
 EUT : Tri Band 900/1800/1900 Handset
 Model : M100
 Power : 120Vac/60Hz
 Memo : PCS 1900MHz CH810

1	1909.830	121.79	-----	-----	93.42	26.78	1.59	0.00	Peak	---	---
MHz	dBuV/m	dB	dBuV/m	dBuV	dB	dB	dB	dB	cm	deg	

Name of Test: Transmitter Conducted Measurements

Specification: 47 CFR 2.1051: Unwanted (spurious) Emissions
2.1049(c), 24.238(b): Occupied Bandwidth
24: Emissions at Band Edges

Test Equipment: As per attached page

Measurement Procedure

1. The EUT and test equipment were set up as shown on the following page with the Spectrum Analyzer connected.
2. The low and high channels for all RF powers within the transmitting frequency band were measured.
3. Measurement Results: Attached



Tested By:

Tim Kao

Transmitter Spurious Emission

Test A. Occupied Bandwidth (In-Band Spurious)
Test B. Out-of-Band Spurious

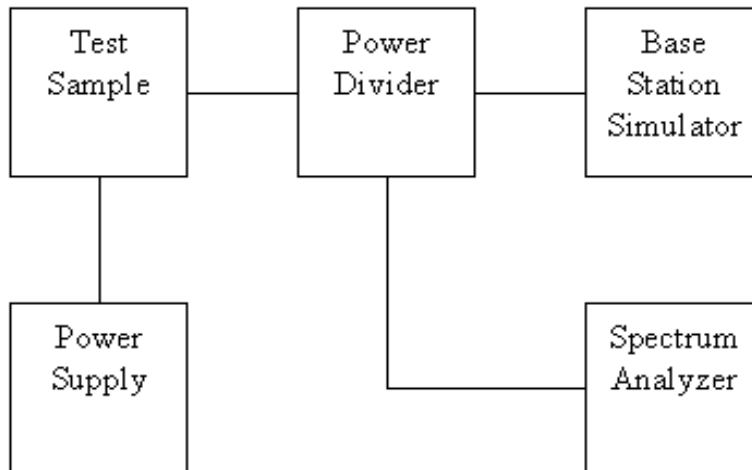

Asset	Model Name	S/N
Base Station Simulator	CMU200	102278
Base Station Simulator	E5515C	GB43460754
Spectrum Analyzer	FSP30	838858/014
AC/DC Power Source	HPA-500W	HPA0100024

Name of Test: Emission Masks (Occupied Bandwidth)
 State 2:High Power



Ref 30 dBm *Att 40 dB *RBW 3 kHz Marker 1 [T1] -18.61 dBm
 *VBW 3 kHz 1.849996000 GHz
 *SWT 300 ms

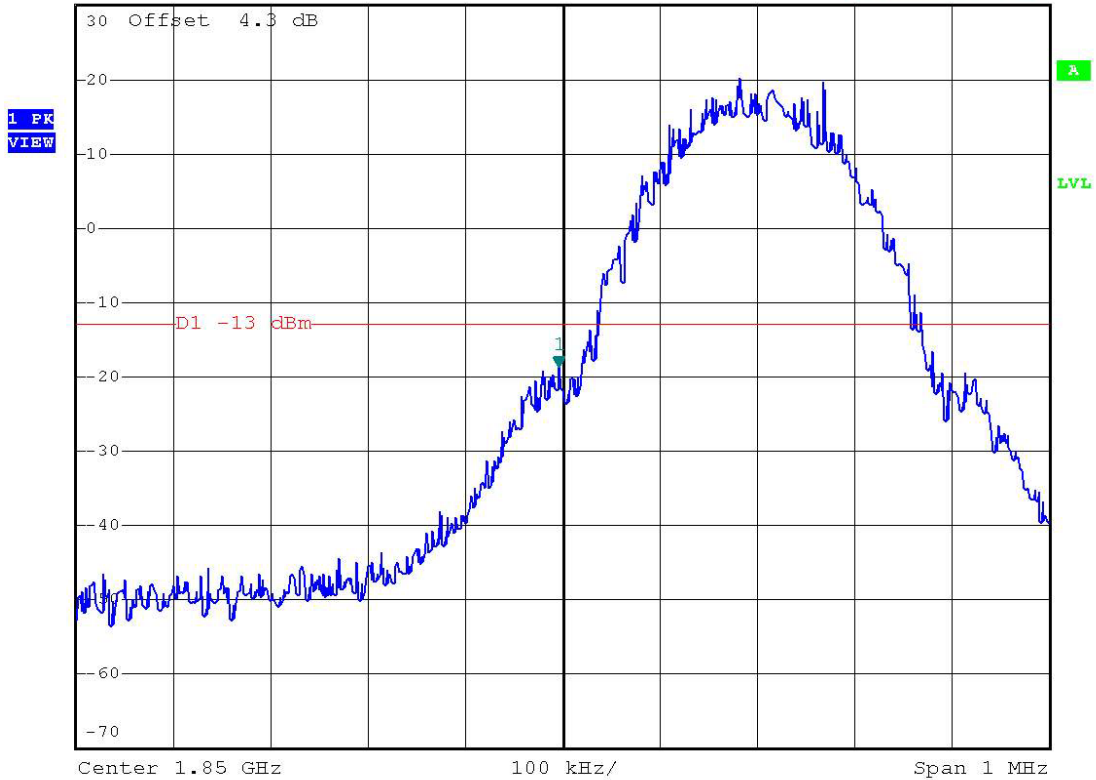

Power: HIGH
 Modulation: GSM 1900
 LOWER BAND EDGE

Name of Test: Emission Masks (Occupied Bandwidth)
 State 1:Low Power



1 PK
VIEW

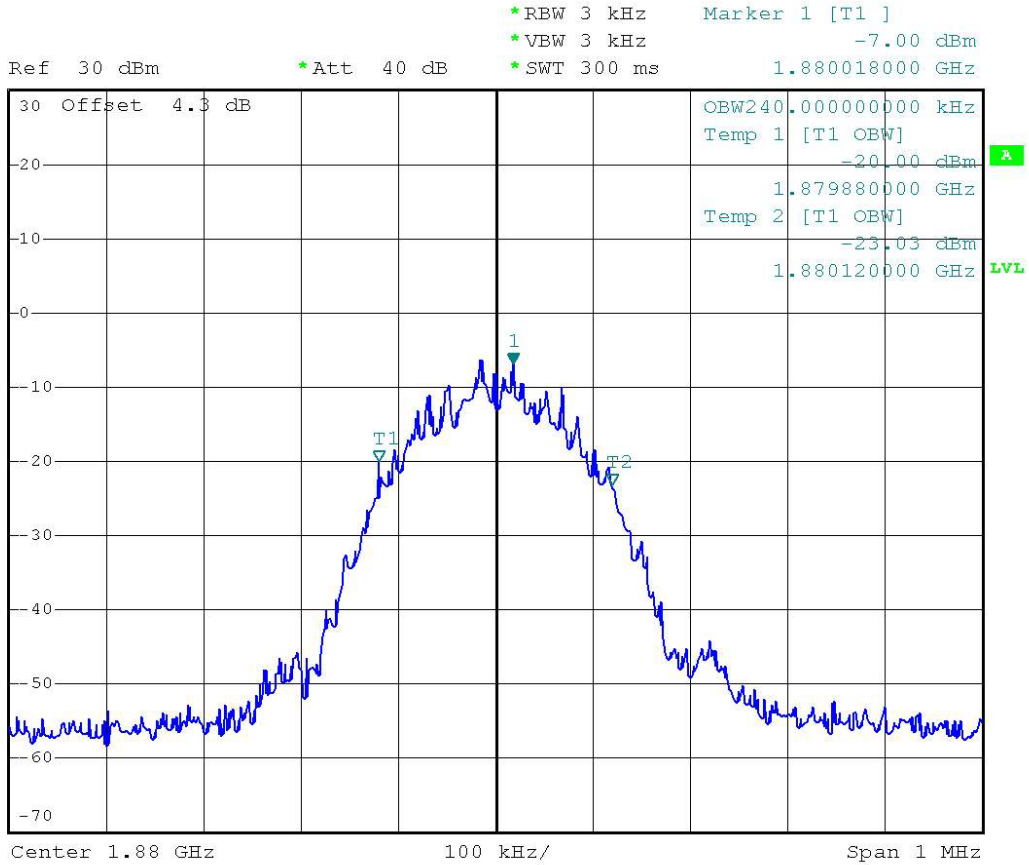

Power: LOW
 Modulation: GSM 1900
 99% BANDWIDTH

Name of Test: Emission Masks (Occupied Bandwidth)
 State 2:High Power

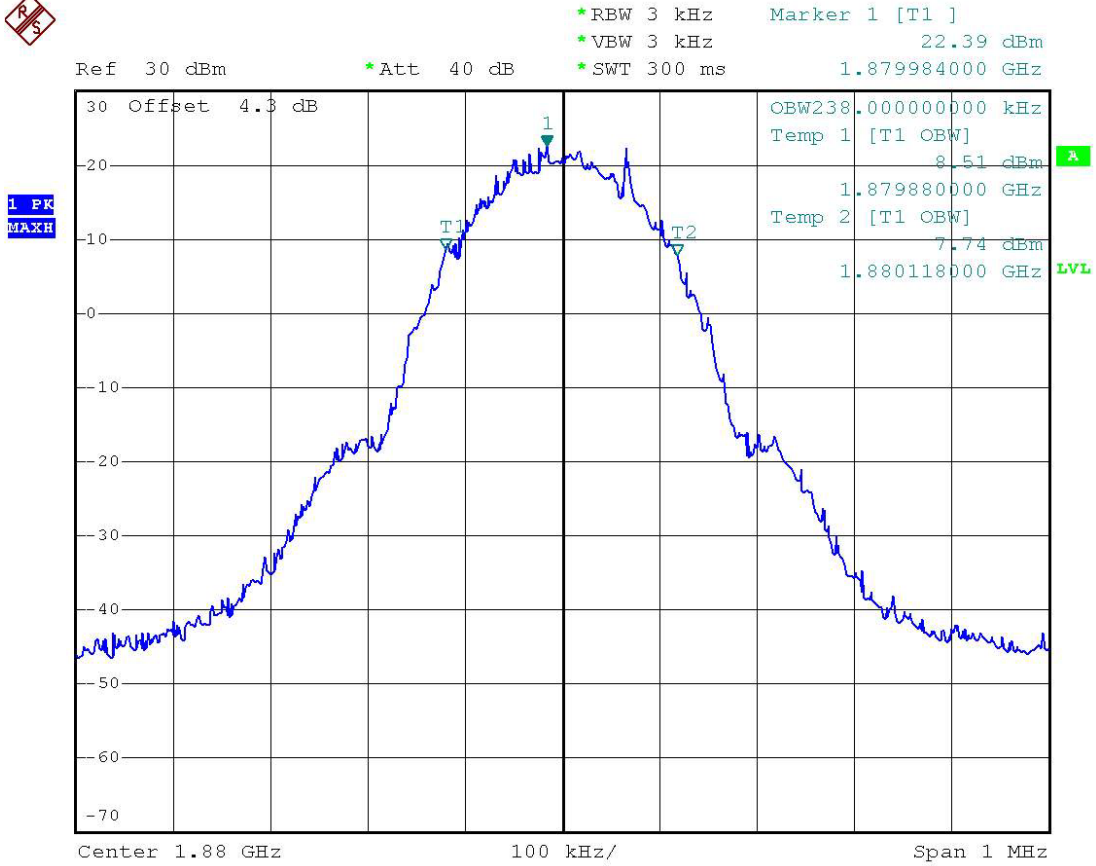

Power: HIGH
 Modulation: GSM 1900
 99% BANDWIDTH

FCC TEST REPORT

Report No. : F461002

Name of Test: Emission Masks (Occupied Bandwidth)
State 2:High Power



*RBW 3 kHz Marker 1 [T1]
*VBW 3 kHz -17.00 dBm
*SWT 300 ms 1.910004000 GHz

Ref 30 dBm *Att 40 dB

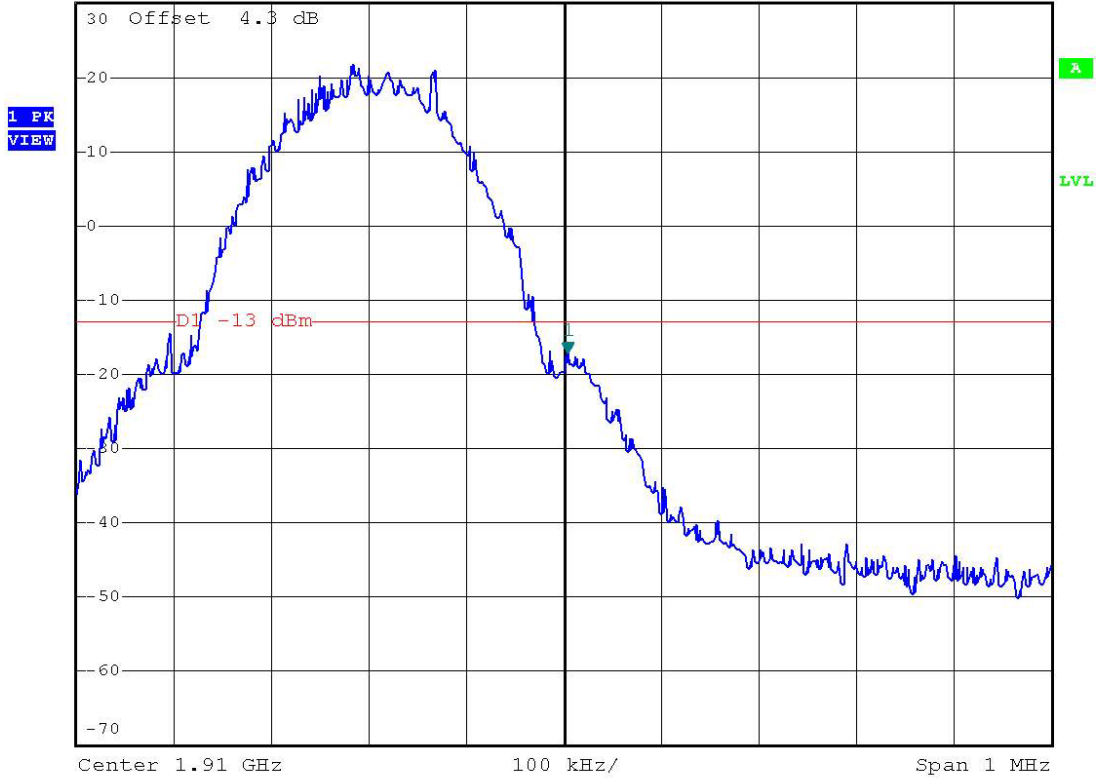

Power: HIGH
Modulation: GSM 1900
UPPER BAND EDGE

Name of Test: Field Strength of Spurious Radiation

Specification: 47 CFR 2.1053(a)

Guide: ANSI/TIA/EIA-603-1992/2001, Paragraph 1.2.12 and Table 16

Measurement Procedure

1.2.12.1 Definition: Radiated spurious emissions are emissions from the equipment when transmitting into a non-radiating load on a frequency or frequencies which are outside an occupied band sufficient to ensure transmission of information of required quality for the class of communications desired.

1.2.12.2 Method of Measurement

A) Connect the equipment as illustrated

B) Adjust the spectrum analyzer for the following settings:

- 1) Resolution Bandwidth 100 kHz (<1 GHz), 1 MHz (> 1GHz).
- 2) Video Bandwidth \geq 3 times Resolution Bandwidth
- 3) Sweep Speed \leq 2000 Hz/second
- 4) Detector Mode = Mean or Average Power

C) Place the transmitter to be tested on the turntable in the standard test site. If the antenna is detachable, The transmitter is transmitting into a non-radiating load which is placed on the turntable. The RF cable to this load should be of minimum length.

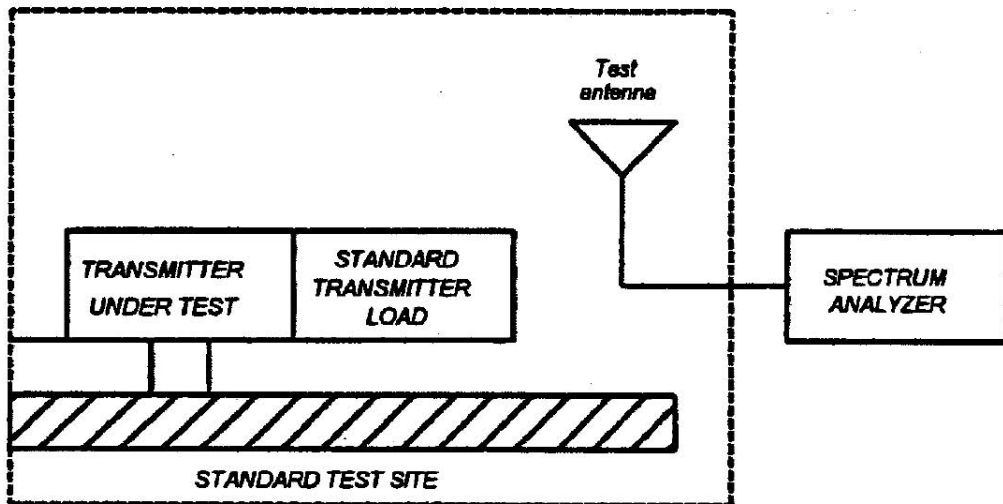

Name of Test: Field Strength of Spurious Radiation (Cont.)

- D) For each spurious measurement the test antenna should cover the measured frequency. Measurements shall be made from the lowest radio frequency generated in the equipment to the tenth harmonic of the carrier, except for the region close to the carrier equal to \pm the test bandwidth (see section 1.3.4.4).
- E) For each spurious frequency, raise and lower the test antenna from 1 m to 4 m to obtain a maximum reading on the spectrum analyzer with the test antenna at horizontal polarity. Repeat this procedure to obtain the highest possible reading. Record this maximum reading.
- F) Repeat step E) for each spurious frequency with the test antenna polarized vertically.

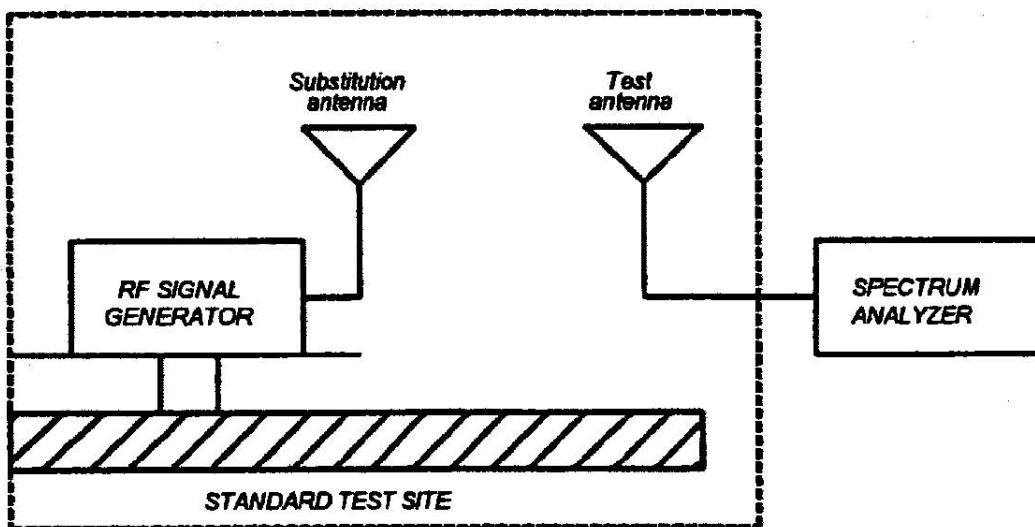

- G) Reconnect the equipment as illustrated.
- H) Keep the spectrum analyzer adjusted as in step B).
- I) Remove the transmitter and replace it with a substitution antenna. The center of the substitution antenna should be approximately at the same location as the center of the transmitter. At lower frequencies, where the substitution antenna is very long, this will be impossible to achieve when the antenna is polarized vertically. In such case the lower end of the antenna should be 0.3 m above the ground.

Name of Test: Field Strength of Spurious Radiation (Cont.)

- J) Feed the substitution antenna at the transmitter end with a signal generator connected to the antenna by means of a non-radiating cable. With the antennas at both ends horizontally polarized and with the signal generator tuned to a particular spurious frequency, raise and lower the test antenna to obtain a maximum reading at the spectrum analyzer. Adjust the level of the signal generator output until the previously recorded maximum reading for this set of conditions is obtained. This should be done carefully repeating the adjustment of the test antenna and generator output.
- K) Repeat step J) with both antennas vertically polarized for each spurious frequency.
- L) Calculate power in dBm into a reference ideal half-wave dipole antenna by reducing the readings obtained in steps J) and K) by the power loss in the cable between the generator and the antenna and further corrected for the gain of the substitution antenna used relative to an ideal half-wave dipole antenna.

NOTE: It is permissible that other antennas provided can be referenced to a dipole.



Tested By:

Tim Kao

Name of Test: Field Strength of Spurious Radiation
GSM 1900 (Channel 661)

Freq MHz	Pol	Substitution Antenna Input Power (dBm)	Substitution Antenna Gain (dBi)	Et (dBuV/m)	Es (dBuV/m)	Et - Es (dB)	EIRP (dBm)	Limit (dBm)	Margin (dB)
48.87	H	-0.67	0.29	21.46	78.39	-56.93	-57.31	-13.0	-44.31
99.53	H	-1.05	2.42	20.81	92.56	-71.75	-70.39	-13.0	-57.39
212.00	H	-1.30	1.32	32.70	90.64	-57.94	-57.92	-13.0	-44.92
700.80	H	-2.35	1.40	29.99	94.89	-64.90	-65.84	-13.0	-52.84
957.60	H	-2.58	0.67	31.33	93.29	-61.96	-63.87	-13.0	-50.87
5638.00	H	-6.67	8.44	48.66	98.79	-50.13	-48.36	-13.0	-35.36
8780.00	H	-8.77	8.88	51.61	94.00	-42.39	-42.28	-13.0	-29.28
10606.00	H	-10.49	8.86	53.71	96.22	-42.51	-44.14	-13.0	-31.14
12246.00	H	-12.11	11.00	57.32	90.40	-33.08	-34.18	-13.0	-21.18
47.51	V	-0.66	0.28	26.72	76.88	-50.16	-50.54	-13.0	-37.54
56.18	V	-0.80	0.34	21.52	82.70	-61.18	-61.64	-13.0	-48.64
301.60	V	-1.49	1.65	23.90	93.18	-69.28	-69.12	-13.0	-56.12
700.80	V	-2.35	1.40	30.31	94.89	-64.58	-65.52	-13.0	-52.52
832.00	V	-2.49	0.58	31.37	93.77	-62.40	-64.31	-13.0	-51.31
3758.00	V	-5.25	7.45	49.70	99.07	-49.37	-47.17	-13.0	-34.17
4380.00	V	-5.98	8.08	51.95	99.60	-47.65	-45.55	-13.0	-32.55
5638.00	V	-6.67	8.44	50.18	98.79	-48.61	-46.84	-13.0	-33.84
8382.00	V	-8.03	9.08	51.45	92.89	-41.44	-40.39	-13.0	-27.39
9398.00	V	-9.78	8.94	55.55	95.76	-40.21	-41.06	-13.0	-28.06
12300.00	V	-12.16	10.94	57.38	90.12	-32.74	-33.96	-13.0	-20.96

Radiated Scanned Data

GSM1900, Horizontal Polarization

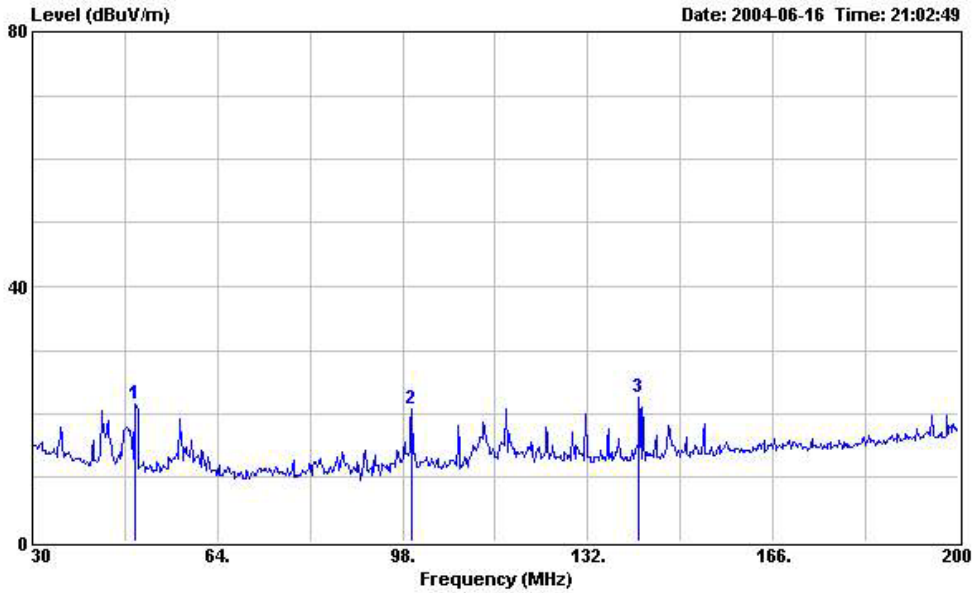

Site : 03CH03-HY
 Condition : 3m BIC-9124--301 HORIZONTAL
 EUT : Tri Band 900/1800/1900 Handset
 Model : M100
 Power : 120Vac/60Hz
 Memo : PCS 1900MHz CH661

Freq	Level	Over Limit		Read Level	Probe Factor	Cable Loss	Preamp Factor	Remark	Ant Pos	Table Pos
		Limit	Line							
MHz	dBuV/m	dB	dBuV/m	dBuV	dB	dB	dB		cm	deg
1	48.870	21.46	-----	38.08	10.21	1.17	28.00		---	---
2	99.530	20.81	-----	37.18	9.75	1.78	27.90		---	---
3	141.350	22.50	-----	36.42	11.83	2.07	27.82		---	---

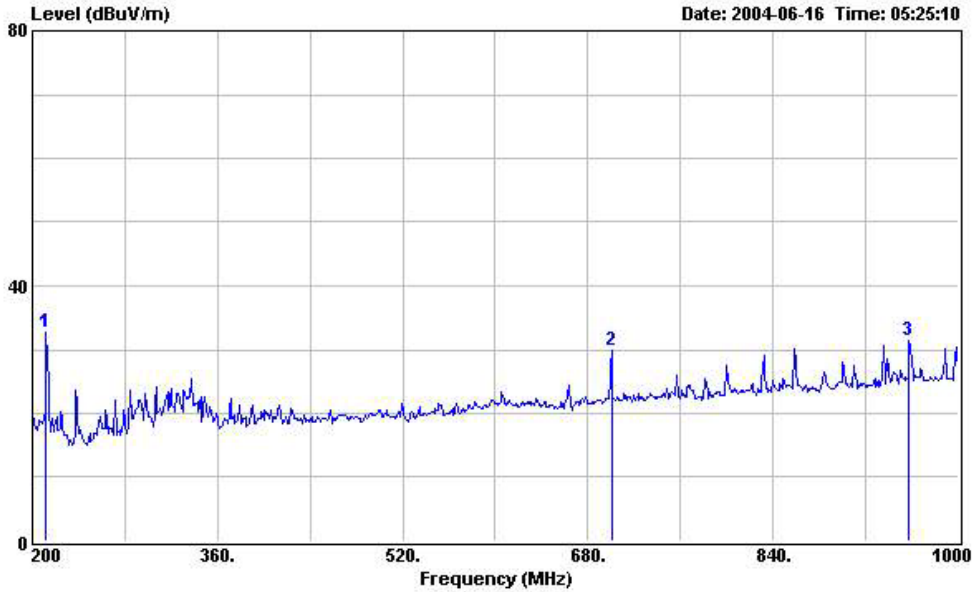

Site : 03CH03-HY
 Condition : 3m LOG-9111-221 HORIZONTAL
 EUT : Tri Band 900/1800/1900 Handset
 Model : M100
 Power : 120Vac/60Hz
 Memo : PCS 1900MHz CH661

	Freq	Level	Over Limit	Limit Line	Read Level	Probe Factor	Cable Loss	Preamp Factor	Remark	Ant Pos	Table Pos
	MHz	dBuV/m	dB	dBuV/m	dBuV	dB	dB	dB		cm	deg
1	212.000	32.70	-----	-----	43.10	14.64	2.61	27.65		---	---
2	700.800	29.99	-----	-----	34.23	19.80	4.66	28.70		---	---
3	957.600	31.33	-----	-----	32.02	21.90	5.65	28.24		---	---

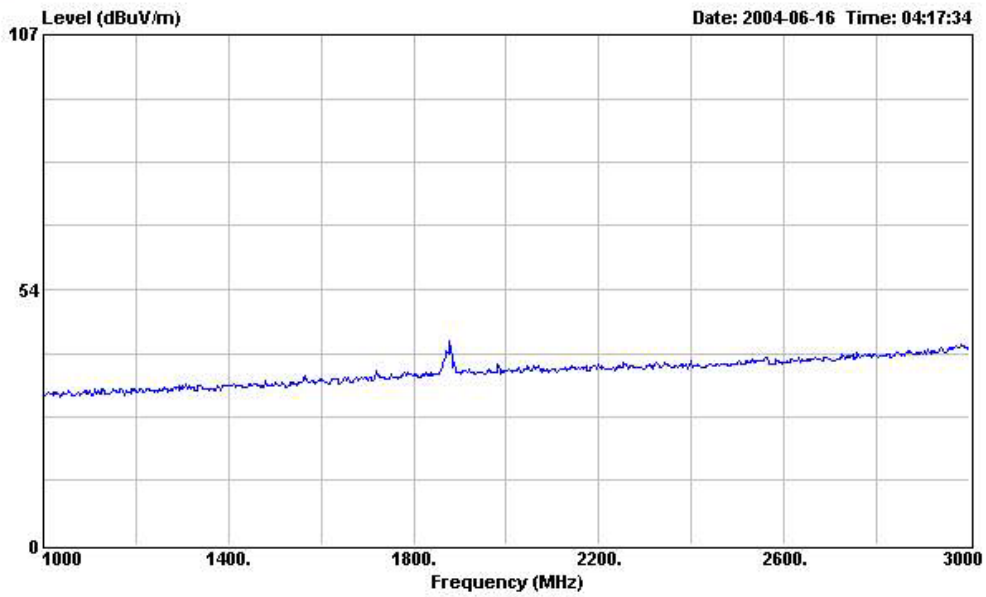

Site : 03CH03-HY
Condition : 3m HORN-ANT-6821 HORIZONTAL
EUT : Tri Band 900/1800/1900 Handset
Model : M100
Power : 120Vac/60Hz
Memo : PCS 1900MHz CH661

FCC TEST REPORT

Report No. : F461002

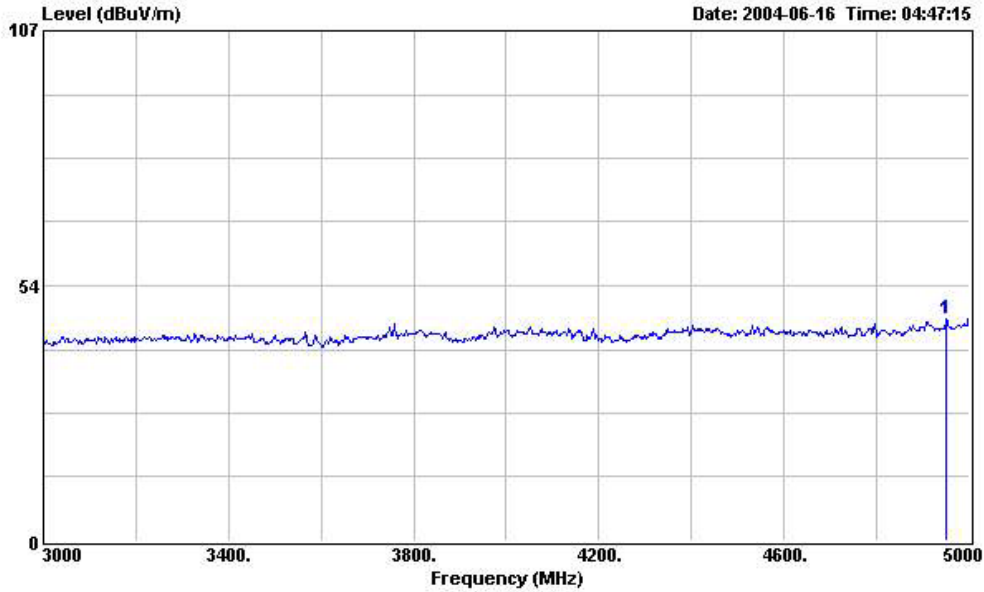

Site : 03CH03-HY
 Condition : 3m HORN-ANT-6821 HORIZONTAL
 EUT : Tri Band 900/1800/1900 Handset
 Model : M100
 Power : 120Vac/60Hz
 Memo : PCS 1900MHz CH661

	Freq	Level	Over Limit	Limit Line	Read Level	Probe Factor	Cable Loss	Preamp Factor	Remark	Ant Pos	Table Pos
	MHz	dBuV/m	dB	dBuV/m	dBuV	dB	dB	dB		cm	deg
1	4950.000	46.42	-----	-----	49.06	33.52	2.44	38.60		---	---