

FCC Test Report

REPORT NO.: RF921015R04

MODEL NO.: P30 (57P30), BenQ P30

RECEIVED: October 15, 2003

TESTED: October 23 ~ October 29, 2003

APPLICANT: BENQ Corporation

ADDRESS: 157, Shan-Ying Road, Gueishan Taoyuan 333,
Taiwan , R.O.C.

ISSUED BY: Advance Data Technology Corporation

LAB LOCATION: 47 14th Lin, Chiapau Tsun, Linko, Taipei,
Taiwan, R.O.C.

This test report consists of 64 pages in total. It may be duplicated completely for legal use with the approval of the applicant. It should not be reproduced except in full, without the written approval of our laboratory. The client should not use it to claim product endorsement by CNLA, NVLAP or any government agencies. The test results in the report only apply to the tested sample.



0528
ILAC MRA



Lab Code: 200102-0

Table of Contents

1	CERTIFICATION	4
2	SUMMARY OF TEST RESULTS	5
3	GENERAL INFORMATION	6
3.1	GENERAL DESCRIPTION OF EUT	6
3.2	DESCRIPTION OF TEST MODES	7
3.3	GENERAL DESCRIPTION OF APPLIED STANDARDS	7
3.4	DESCRIPTION OF SUPPORT UNITS	8
4	TEST TYPES AND RESULTS.....	9
4.1	MODULATION CHARACTERISTICS	9
4.1.1	DESCRIPTION OF MODULATION TECHNIQUE.....	9
4.1.2	THE ACTIVE TIME SLOT 3 MODULATED FRAME PLOT.....	9
4.2	OUTPUT POWER MEASUREMENT	11
4.2.1	LIMITS OF OUTPUT POWER MEASUREMENT	11
4.2.2	TEST INSTRUMENTS	11
4.2.3	TEST PROCEDURES.....	12
4.2.4	TEST SETUP	13
4.2.5	EUT OPERATING CONDITIONS	14
4.2.6	TEST RESULTS.....	15
4.3	FREQUENCY STABILITY MEASUREMENT	17
4.3.1	LIMITS OF FREQUENCY STABILITY MEASUREMENT	17
4.3.2	TEST INSTRUMENTS	17
4.3.3	TEST PROCEDURE	18
4.3.4	TEST SETUP	18
4.3.5	TEST RESULTS.....	19
4.4	OCCUPIED BANDWIDTH MEASUREMENT	21
4.4.1	LIMITS OF OCCUPIED BANDWIDTH MEASUREMENT.....	21
4.4.2	TEST INSTRUMENTS	21
4.4.3	TEST SETUP	21
4.4.4	TEST PROCEDURES.....	22
4.4.5	EUT OPERATING CONDITION.....	22
4.4.6	TEST RESULTS.....	22
4.5	BAND EDGE MEASUREMENT	29
4.5.1	LIMITS OF BAND EDGE MEASUREMENT	29
4.5.2	TEST INSTRUMENTS	29
4.5.3	TEST SETUP	29
4.5.4	TEST PROCEDURES.....	30

4.5.5	EUT OPERATING CONDITION	30
4.5.6	TEST RESULTS	31
4.6	CONDUCTED SPURIOUS EMISSIONS	33
4.6.1	LIMITS OF CONDUCTED SPURIOUS EMISSIONS MEASUREMENT	33
4.6.2	TEST INSTRUMENTS	33
4.6.3	TEST PROCEDURE	34
4.6.4	TEST SETUP	34
4.6.5	EUT OPERATING CONDITIONS	34
4.6.6	TEST RESULTS	35
4.7	RADIATED EMISSION MEASUREMENT.....	47
4.7.1	LIMITS OF RADIATED EMISSION MEASUREMENT	47
4.7.2	TEST INSTRUMENTS	47
4.7.3	TEST PROCEDURES.....	48
4.7.4	TEST SETUP	49
4.7.5	EUT OPERATING CONDITIONS	49
4.7.6	TEST RESULTS	50
5	PHOTOGRAPHS OF THE TEST CONFIGURATION	62
6	INFORMATION ON THE TESTING LABORATORIES	64

1 CERTIFICATION

PRODUCT : Smartphone
MODEL NO. : P30 (57P30), BenQ P30
BRAND NAME : BenQ
TEST ITEM: BENQ Corporation
APPLICANT : ENGINEERING SAMPLE
TEST STANDARDS : FCC Part 24, Subpart E,
ANSI C63.4-2001

We, **Advance Data Technology Corporation**, hereby certify that one sample of the designation has been tested in our facility from October 23 ~ October 29, 2003. The test record, data evaluation and Equipment Under Test (EUT) configurations represented herein are true and accurate accounts of the measurements of the sample's EMC characteristics under the conditions herein specified.

PREPARED BY: Wendy Liao. , DATE: Nov. 03, 2003

Wendy Liao

APPROVED BY: Ellis Eu , DATE: Nov. 03, 2003

Ellis Eu / Manager

2 SUMMARY OF TEST RESULTS

The EUT has been tested according to the following specifications:

APPLIED STANDARD: FCC Part 24 & Part 2 / IC RSS-133			
Standard Section	Test Type and Limit	Result	REMARK
2.1047(d)	Modulation Characteristics	PASS	NA
2.1046, 24.232	Maximum Peak Output Power Limit: max. 2 watts e.i.r.p peak power	PASS	Meet the requirement of limit Minimum passing margin is 28.7dBm at 1880.00MHz
2.1055, 24.235	Frequency Stability AFC Freq. Error vs. Voltage AFC Freq. Error vs. Temperature Limit: max. ± 0.1 ppm	PASS	Meet the requirement of limit
2.1049, 24.238(b)	Occupied Bandwidth	PASS	Meet the requirement of limit
24.238(b)	Band Edge Measurements	PASS	NA
2.1051, 24.238	Conducted Spurious Emissions	PASS	Meet the requirement of limit Minimum passing margin is -22.59dB at 9412.00MHz
2.1053, 24.238	Radiated Spurious Emissions	PASS	Meet the requirement of limit Minimum passing margin is -0.14dB at 15040.00MHz

3 GENERAL INFORMATION

3.1 GENERAL DESCRIPTION OF EUT

PRODUCT	Smartphone
MODEL NO.	P30 (57P30), BenQ P30
BRAND NO.	BenQ
POWER SUPPLY	3.6V DC from Battery
MODULATION TYPE	GMSK
FREQUENCY RANGE	Tx Frequency : 1850.2MHz~1909.8MHz (PCS band) Rx Frequency : 1930.2MHz~1989.8MHz (PCS band)
NUMBER OF CHANNEL	299
MAX. CONDUCTED PEAK OUTPUT POWER	29.20dBm(0.832Watts)
MAX. RADITED EIRP PEAK OUTPUT POWER	28.70dBm(0.741Watts)
ANTENNA TYPE	External antenna with Tri-band 50 Ohm
DATA CABLE	NA
I/O PORTS	NA
ASSOCIATED DEVICES	Earphone plus Microphone and SD memory Card
EUT Temp. Tolerance	-30°C to +50°C
EUT Extreme Vol. Range	3.3VCD to 4.2VDC

NOTE

1. BenQ P30 is for marking name.
2. For more detailed features description, please refer to the manufacturer's specifications or User's Manual.

3.2 DESCRIPTION OF TEST MODES

299 channels are provided to this EUT in the PCS1900 band. Therefore choice the low, middle and high channel to testing.

Channel	Frequency	Channel	Frequency
512(low cha.)	1850.2MHz	661(middle cha.)	1880.0 MHz
810(high cha.)	1909.8 MHz	NA	

NOTE:

1. Below 1 GHz, the channel 512, 661, and 810 were pre-tested in chamber. The channel 512, worst case one, was chosen for final test.
2. Above 1 GHz, the channel 512, 661, and 810 were tested individually.
3. When the Power Control Level set 0, the worst case, was chosen for final test.
4. The channel space is 0.2MHz.

3.3 GENERAL DESCRIPTION OF APPLIED STANDARDS

The EUT is a Smartphone. According to the specifications of the manufacturer, it must comply with the requirements of the following standards:

FCC Part 2

FCC Part 24

IC RSS-133

ANSI C63.4 : 2001

All tests have been performed and recorded as per the above standards.

FCC ID: JVP57P30

3.4 DESCRIPTION OF SUPPORT UNITS

The EUT has been tested as an independent unit together with other necessary accessories or support units. The following support units or accessories were used to form a representative test configuration during the tests.

NO.	PRODUCT	BRAND	MODEL NO.	SERIAL NO.	FCC ID
1	GSM MS SET	Agilent	E6392B	JP5MG01384	2004/03/04

NO.	SIGNAL CABLE DESCRIPTION OF THE ABOVE SUPPORT UNITS
1	NA

NOTE: All power cords of the above support units are non shielded (1.8m).

4 TEST TYPES AND RESULTS

4.1 MODULATION CHARACTERISTICS

4.1.1 DESCRIPTION OF MODULATION TECHNIQUE

According to FCC 2.1047(d), the system is used the digital modulation and accomplished with the PCS requirement as defined in the 3GGP TS 05:01, TS 05:02, TS 05:04. It uses narrowband TDMA. Eight simultaneous calls can occupy the same radio frequency.

There are 299 channels and channel space is 200kHz. The frequency band 1850~1910MHz is allocated to the uplink and 1930~1990MHz to the downlink. The uplink and downlink channel space is 80MHz and is duplex at the same time.

The modulation scheme used the GMSK (Gaussian Minimum Shift Keying) that is the special case of FSK (frequency Shift Keying). The each time slot is last about 580μs and data length is 156.25bits. A frame contains the eight time slots.

4.1.2 THE ACTIVE TIME SLOT 8 MODULATED FRAME PLOT

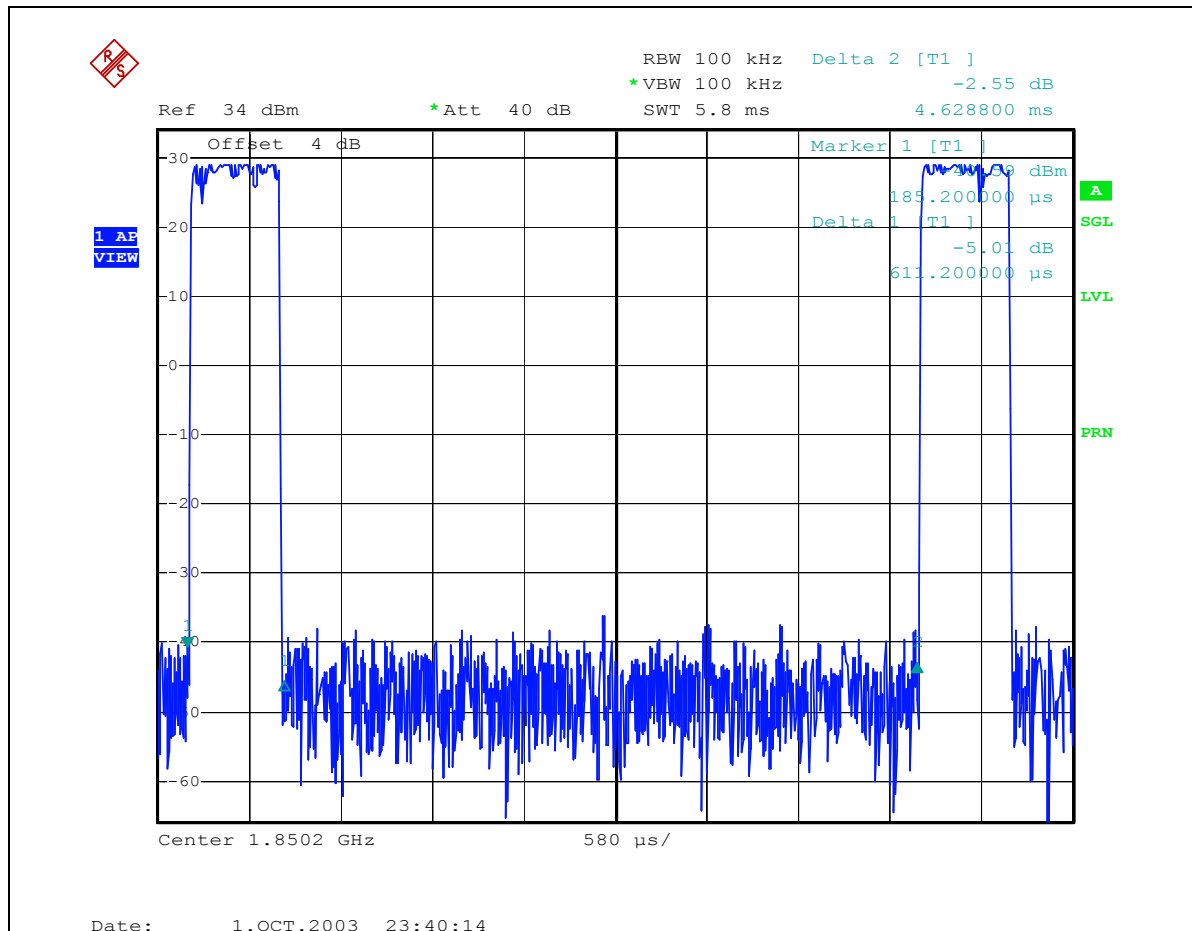

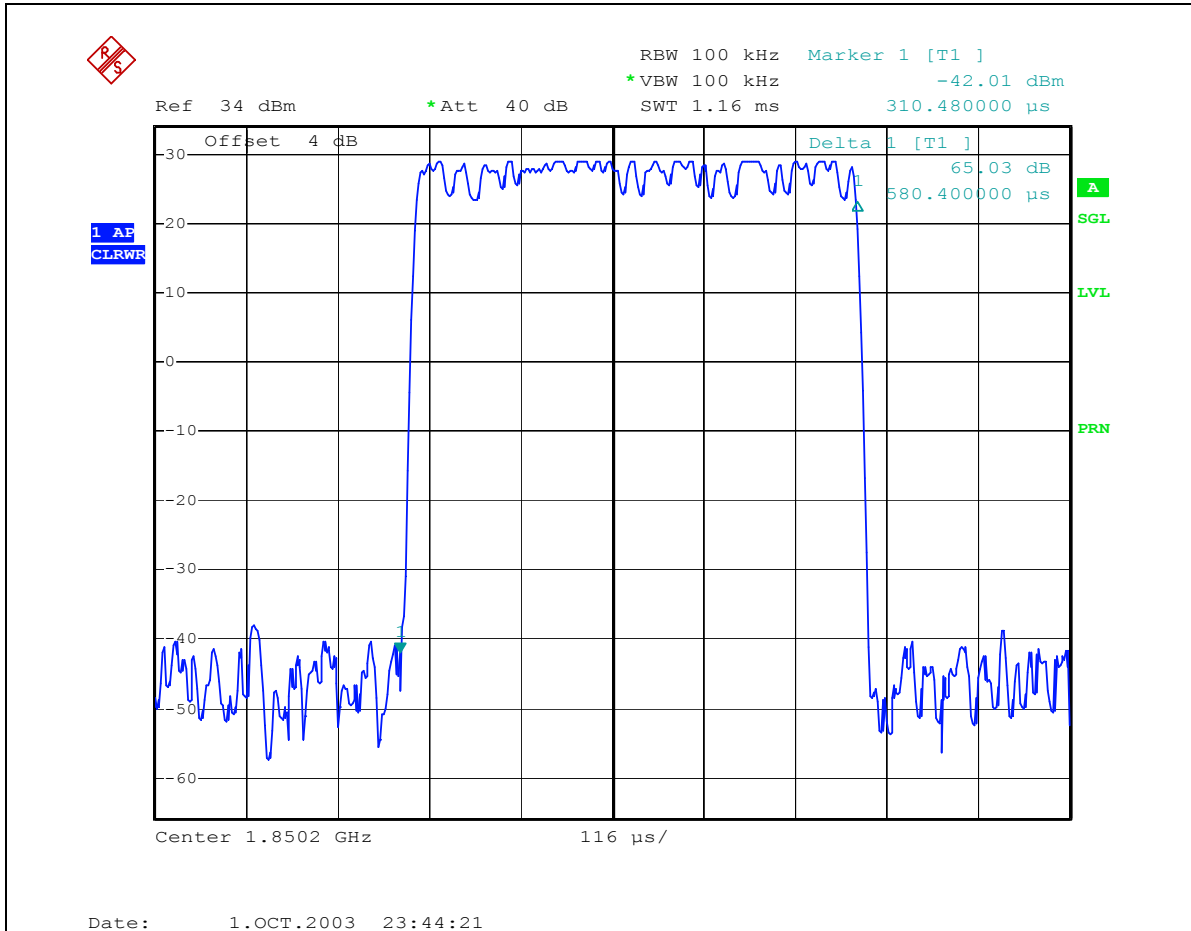

4.2 OUTPUT POWER MEASUREMENT

4.2.1 LIMITS OF OUTPUT POWER MEASUREMENT

The radiated peak output power shall be according to the specific rule Part 24.232(b) that “Mobile / Portable station are limited to 2 watts e.i.r.p” and 24.232(c) specific that “Peak transmit power must be measure over any interval of continuous transmission using instrumentation calibration in terms of rms-equivalent voltage.”

4.2.2 TEST INSTRUMENTS

DESCRIPTION & MANUFACTURER	MODEL NO.	SERIAL NO.	CALIBRATED UNTIL
* ROHDE & SCHWARZ Spectrum Analyzer	FSP40	100035	Apr. 15, 2004
* ROHDE & SCHWARZ Signal Generator	SMP04	10001	May 05, 2004
* ROHDE & SCHWARZ Universal Radio Communication Tester	CMU200	836072/086	Apr. 21, 2004
* EMCO Horn Antenna	3115	9811-5623	Jul. 27, 2004
* EMCO Horn Antenna	3115	9811-5619	Jul. 15, 2004
* EMCO Turn Table & Tower Controller	2090	NA	NA
* Software	ADT_Radiated_V 5.14	NA	NA
* Mini-Circuits Power Splitter	ZAPD-4	400005	NA
* Hewlett Packard RF cable	8120-6192	01428251	NA
* JFW 20dB attenuation	50HF-020-SMA	NA	NA
* Suhner RF cable	Sucoflex104	204850/4	NA

- NOTE:** 1. The calibration interval of the above test instruments is 12 months. And the calibrations are traceable to NML/ROC and NIST/USA.
 2. “*” = These equipments are used for the final measurement.
 3. The test was performed in ADT RF fully anechoic chamber No. 2.

4.2.3 TEST PROCEDURES

- a. The EUT was set up for the maximum peak power with GPRS link data modulation. The power was measured with R&S Spectrum Analyzer. All measurements were done at 3 channels, 512, 661 and 810(low, middle and high operational frequency range.)
- b. The conducted peak output power used the power splitter via EUT RF power connector between simulation base station and spectrum analyzer. The path loss included the splitter loss, cable loss and 20dB pad loss. The spectrum set RB/VB 3MHz, then read peak power value and record to the test. (All transmitted path loss shall be considered in the test report data.)
- c. E.I.R.P peak power measurement. In the fully anechoic chamber, EUT placed on the 1.5m height of Turn Table, rotated the table around 360 degrees to search the maximum radiation power and receiver antenna shall be rotated vertical and horizontal polarization to find the maximum polar radiated power. The "Read Value" is the spectrum reading the maximum power value.
- d. The substitution horn antenna is substituted for EUT at the same position and signal generator export the CW signal to the calibration antenna. Rotated the Turn Table to find the maximum radiation power. "Raw" is the spectrum reading value, "SG" is signal generator export power, "TX Gain" is calibration antenna isotropic gain value, "TX cable" is the transmitted cable loss between the calibration antenna and signal generator. The "Factor" means that the transmission path loss is equal to "SG" - "TX cable" + "TX Gain" - "Raw".
- e. Actually the real E.I.R.P peak power is equal to "Read Value" + "Factor"
- f. E.R.P power can be calculated form E.I.R.P power by subtracting the gain of dipole, $E.R.P \text{ power} = E.I.P.R \text{ power} - 2.15\text{dBi}$.

NOTE:

1. The resolution bandwidth and video bandwidth of test receiver/spectrum analyzer is 3MHz for Peak detection (PK)

4.2.4 TEST SETUP

EIRP Power Measurement

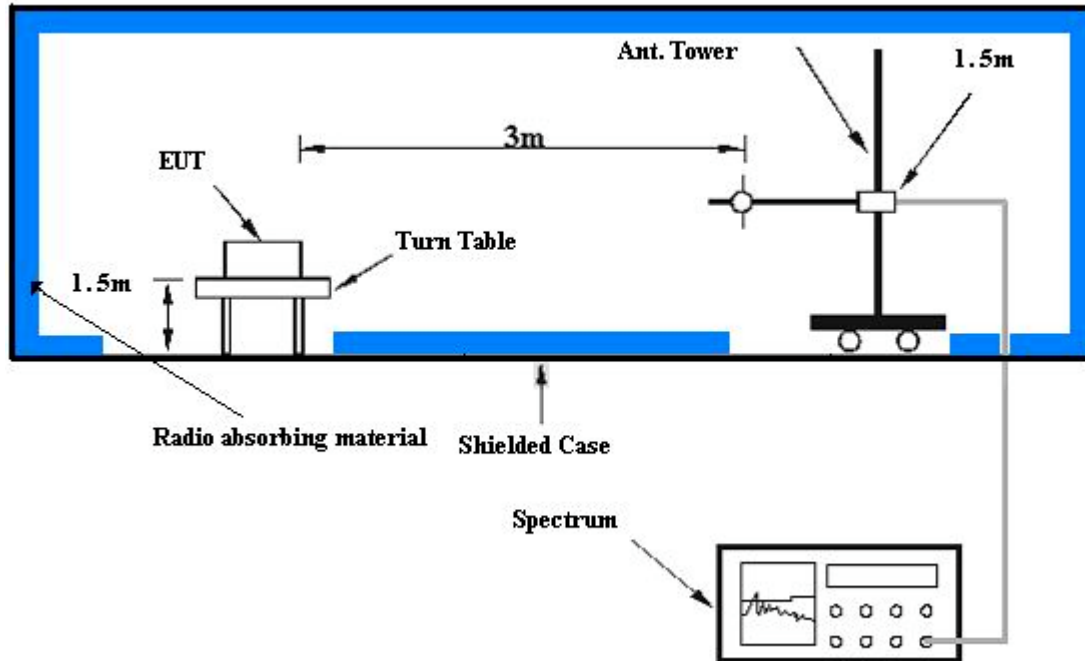

For the actual test configuration, please refer to the related item – Photographs of the Test Configuration.

Conducted Power Measurement

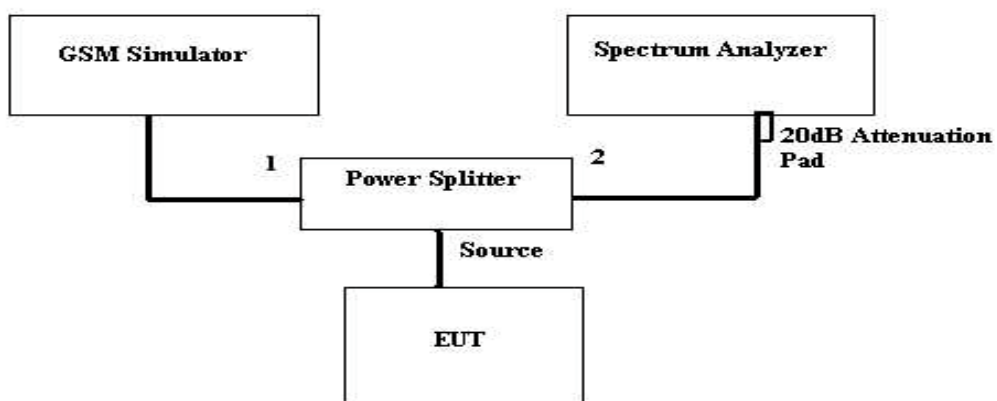

For the actual test configuration, please refer to the related item – Photographs of the Test Configuration.

4.2.5 EUT OPERATING CONDITIONS

- a. The EUT makes a phone call to the GSM simulator.
- b. The GSM simulator station system controlled a EUT to export maximum output power under transmission mode and specific channel frequency.

FCC ID: JVP57P30

4.2.6 TEST RESULTS

EUT	Smartphone	MODEL	P30 (57P30), BenQ P30
MODE	TX connected	POWER CONTROL LEVEL	0
INPUT POWER (SYSTEM)	120Vac, 60 Hz	DETECTOR FUNCTION	Peak
ENVIRONMENTAL CONDITIONS	24 deg. C, 50 % RH, 999 hPa	TESTED BY: Bunny Yao	

CONDUCTED PEAK OUTPUT POWER					
Channel No.	Frequency (MHz)	Raw Value (dBm)	Correction Factor (dB)	Peak Output Power	
				dBm	Watt
512	1850.2	3.49	25.41	28.90	0.776
661	1880.0	3.61	25.59	29.20	0.832
810	1909.8	3.42	25.68	29.10	0.813

REMARKS:

1. Peak Output Power(dBm)=Raw Value(dBm) + Correction Factor(dB)
2. Correction Factor(dB) = Power Splitter Loss(dB) + Cable Loss(dB)

FCC ID: JVP57P30

EUT	Smartphone	MODEL	P30 (57P30), BenQ P30
MODE	Tx	POWER CONTORL LEVEL	0
INPUT POWER (SYSTEM)	120Vac, 60 Hz	DETECTOR FUNCTION	Peak
ENVIRONMENTAL CONDITIONS	24 deg. C, 50 % RH, 999 hPa	TESTED BY: Bunny Yao	

EIRP RADIATED PEAK OUTPUT POWER					
Channel No.	Frequency (MHz)	Raw Value (dBm)	Correction Factor (dB)	Peak Output Power	
				dBm	Watt
512	1850.2	-5.30	34.0	28.7	0.741
661	1880.0	-5.60	34.2	28.6	0.724
810	1909.8	-6.50	34.9	28.4	0.692

REMARKS:

1. Peak Output Power(dBm)=Raw Value(dBm) + Correction Factor(dB)
2. Correction Factor(dB) = Receiver Antenna Gain(dBi) + Cable Loss(dB) + Free Space Loss(dB)

4.3 FREQUENCY STABILITY MEASUREMENT

4.3.1 LIMITS OF FREQUENCY STABILITY MEASUREMENT

According to the FCC part 2.235 shall be tested the frequency stability. The rule is defined that "The frequency stability shall be sufficient to ensure that the fundamental emission stays within the authorized frequency block." The frequency error rate is according to the JTC standard that the frequency error rate shall be accurate to within 0.1 ppm of the received frequency from the base station. The test extreme voltage is according to the 2.1055(d)(1) Vary primary supply voltage from 85 to 115 percent of the nominal value for other than hand carried battery equipment and the extreme temperature rule is comply with the 2.1055(a)(1) -30°C ~50°C.

4.3.2 TEST INSTRUMENTS

DESCRIPTION & MANUFACTURER	MODEL NO.	SERIAL NO.	CALIBRATED UNTIL
* ROHDE & SCHWARZ Universal Radio Communication Tester	CMU200	836072/086	Apr. 21, 2004
* Hewlett Packard RF cable	8120-6192	01428251	NA
* Suhner RF cable	Sucoflex104	204850/4	NA
*WIT Standard Temperature & Humidity Chamber	TH-4S-C	W981030	Jul. 12, 2004

- NOTE:**
1. The calibration interval of the above test instruments is 12 months. And the calibrations are traceable to NML/ROC and NIST/USA.
 2. "*" = These equipments are used for the final measurement.
 3. The test was performed in ADT RF OVEN room.

4.3.3 TEST PROCEDURE

- a. Because of the measure the carrier frequency under the condition of the AFC lock, it shall be used the mobile station in the GRRP link mode. This is accomplished with the use of the R&S CMU200 simulator station. The oven room could control the temperatures and humidity. The GPRS link channel is the 661.
- b. Power must be removed when changing from one temperature to another or one voltage to another voltage. Power warm up is at least 15 min and power applied should perform before recording frequency error.
- c. EUT is connected the external power supply to control the DC input power. The various Volts from the minimum 3.3 Volts to 4.2 Volts. Each step shall be record the frequency error rate.
- d. The temperature range step is 10 degrees in this test items. All temperature levels shall be hold the $\pm 0.5^{\circ}\text{C}$ during the measurement testing.
- e. The each temperature step shall be at least 0.5 hours, consider the EUT could be test under the stability condition.

REMARKS: 1. The frequency error was recorded frequency error from the GSM simulator.

4.3.4 TEST SETUP

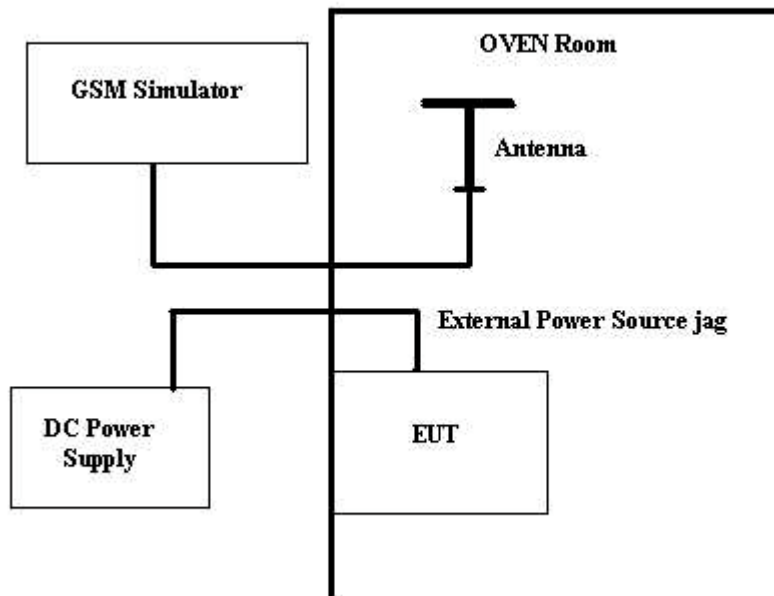

4.3.5 TEST RESULTS

EUT	Smartphone	MODEL	P30 (57P30), BenQ P30
MODE	TX connected	POWER CONTROL LEVEL	0
INPUT POWER (SYSTEM)	120Vac, 60 Hz	DETECTOR FUNCTION	500 Bursts
ENVIRONMENTAL CONDITIONS	25 deg. C, 60 % RH, 999 hPa	TESTED BY: Bunny Yao	

AFC FREQUENCY ERROR vs. VOLTAGE			
Voltage (Volts)	Frequency Error (Hz)	Frequency Error (ppm)	Limit(ppm)
3.3	41	0.022	0.1
3.4	26	0.014	0.1
3.5	14	0.007	0.1
3.6	25	0.013	0.1
3.7	47	0.025	0.1
3.8	20	0.011	0.1
3.9	69	0.037	0.1
4.0	4	0.002	0.1
4.1	18	0.010	0.1
4.2	24	0.013	0.1

FCC ID: JVP57P30

EUT	Smartphone	MODEL	P30 (57P30), BenQ P30
MODE	TX connected	POWER CONTROL LEVEL	0
INPUT POWER (SYSTEM)	120Vac, 60 Hz	DETECTOR FUNCTION	500 Bursts
ENVIRONMENTAL CONDITIONS	25 deg. C, 60 % RH, 999 hPa	TESTED BY: Bunny Yao	

AFC FREQUENCY ERROR vs. TEMPERATURE			
Temp. (°C)	Frequency Error (Hz)	Frequency Error (ppm)	Limit(ppm)
-30	10	0.005	0.1
-20	7	0.004	0.1
-10	14	0.007	0.1
0	37	0.020	0.1
10	30	0.016	0.1
20	25	0.013	0.1
30	13	0.007	0.1
40	10	0.005	0.1
50	23	0.012	0.1

4.4 OCCUPIED BANDWIDTH MEASUREMENT

4.4.1 LIMITS OF OCCUPIED BANDWIDTH MEASUREMENT

According to FCC 24.238(b) specified that emission bandwidth is defined as the width of the signal between two points, one below the carrier center frequency and one above the carrier center frequency, outside of which all emissions are attenuated at least 26 dB below the transmitter power.

4.4.2 TEST INSTRUMENTS

DESCRIPTION & MANUFACTURER	MODEL NO.	SERIAL NO.	CALIBRATED UNTIL
* ROHDE & SCHWARZ Spectrum Analyzer	FSP40	100035	Apr. 15, 2004
* ROHDE & SCHWARZ Universal Radio Communication Tester	CMU200	836072/086	Apr. 21, 2004
* Mini-Circuits Power Splitter	ZAPD-4	400005	NA
* Hewlett Packard RF cable	8120-6192	01428251	NA
* JFW 20dB attenuation	50HF-020-SMA	NA	NA
* Suhner RF cable	Sucoflex104	204850/4	NA

- NOTE:** 1. The calibration interval of the above test instruments is 12 months. And the calibrations are traceable to NML/ROC and NIST/USA.
 2. "*" = These equipments are used for the final measurement.

4.4.3 TEST SETUP

Same as Item 4.2.4 (Conducted Power Setup)

4.4.4 TEST PROCEDURES

- a. The EUT was set up for the maximum peak power with GPRS link data modulation. The power was measured with R&S Spectrum Analyzer. All measurements were done at 3 channels, 512, 661 and 810(low, middle and high operational frequency range.)
- b. The conducted occupied bandwidth used the power splitter via EUT RF power connector between simulation base station and spectrum analyzer. This splitter loss and cable loss are the worst loss 4dB in the transmitted path track.
- c. FCC 24.238(b) required a measurement bandwidth is the fundamental emission below 26dB bandwidth.

4.4.5 EUT OPERATING CONDITION

- a. The EUT makes a phone call to the GSM simulator.
- b. The GSM simulator station system controlled a EUT to export maximum and minimum output power under transmission mode and specific channel frequency Same as Item 4.4.5

4.4.6 TEST RESULTS

Frequency (MHz)	Max. Output Power -26 dBc Bandwidth (kHz)	Min. Output Power -26 dBc Bandwidth (kHz)
1850.2	312	312
1880.0	312	314
1909.8	316	316

Channel 512 Max. Power -26 dBc Bandwidth

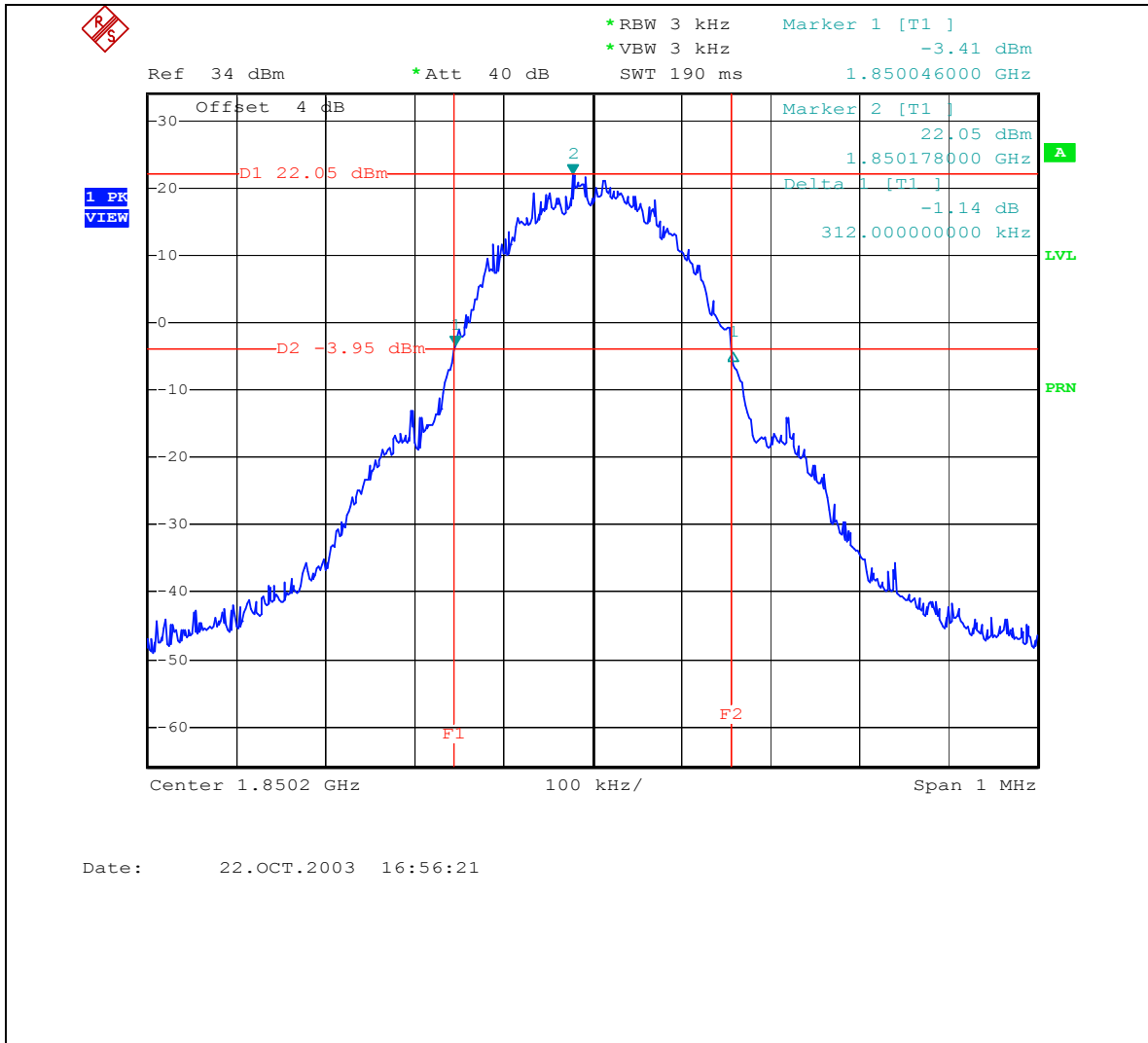

Channel 512 Min. Power -26 dBc Bandwidth

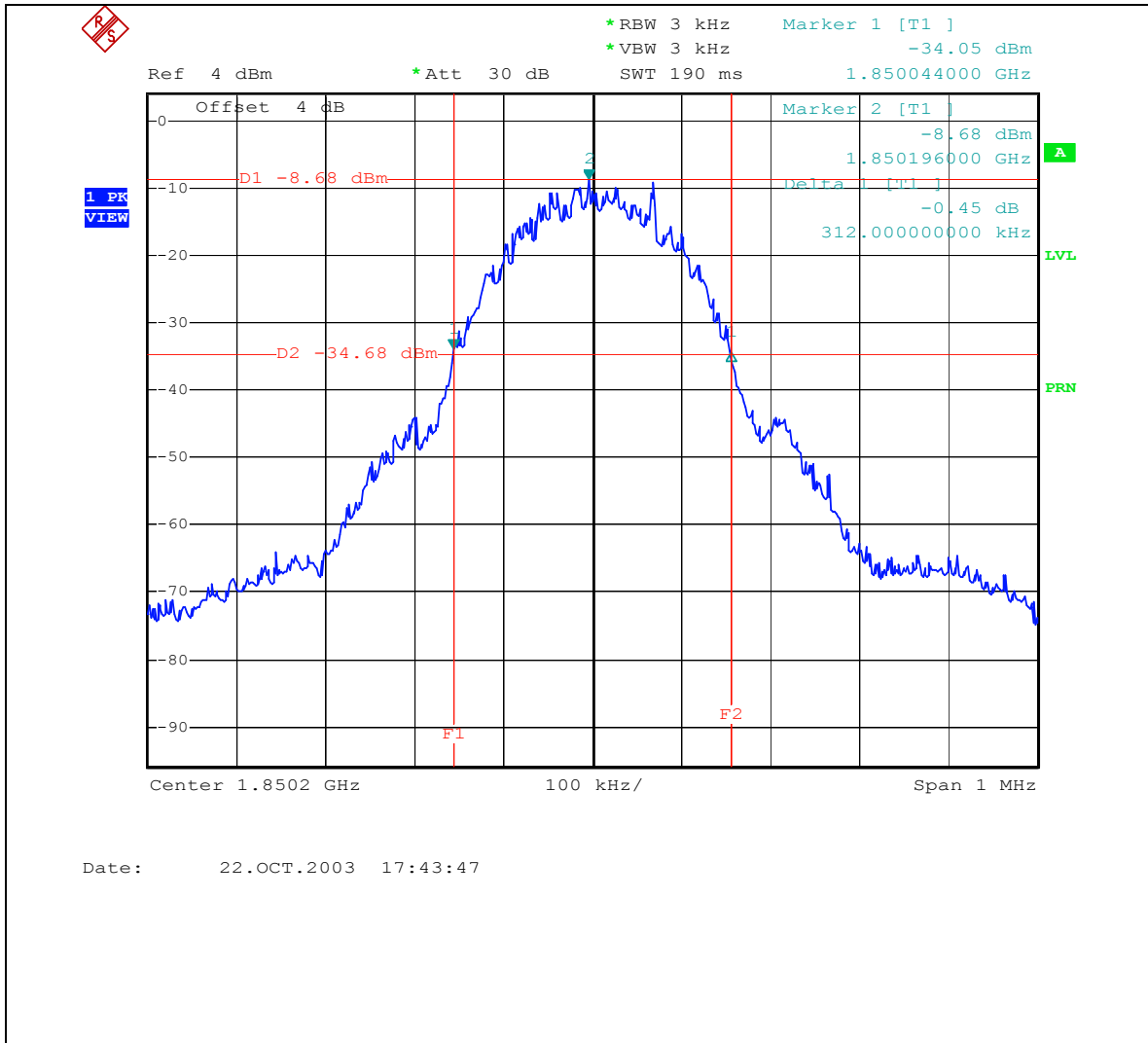

Channel 661 Max. Power -26 dBc Bandwidth

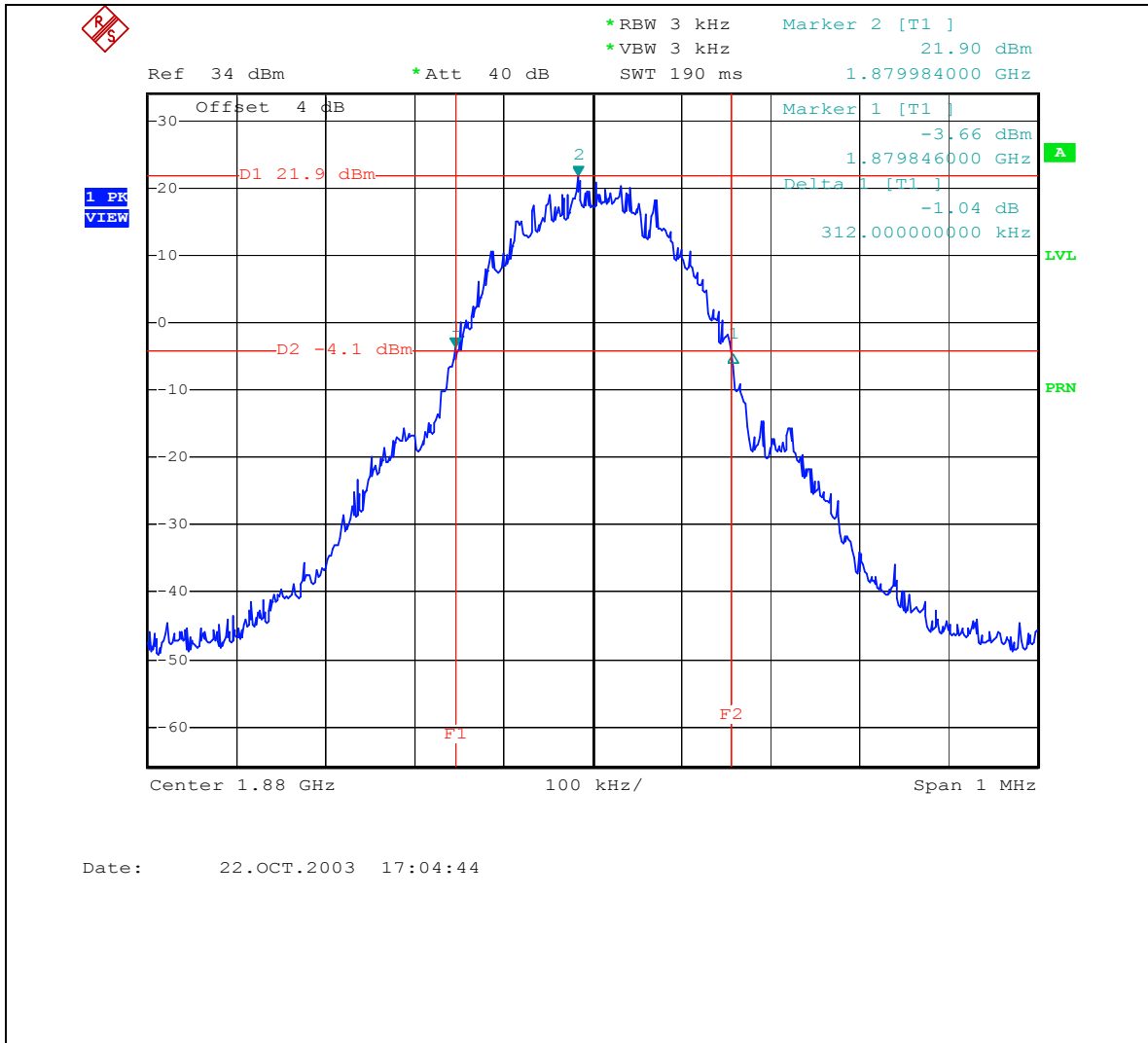

Channel 661 Min. Power -26 dBc Bandwidth

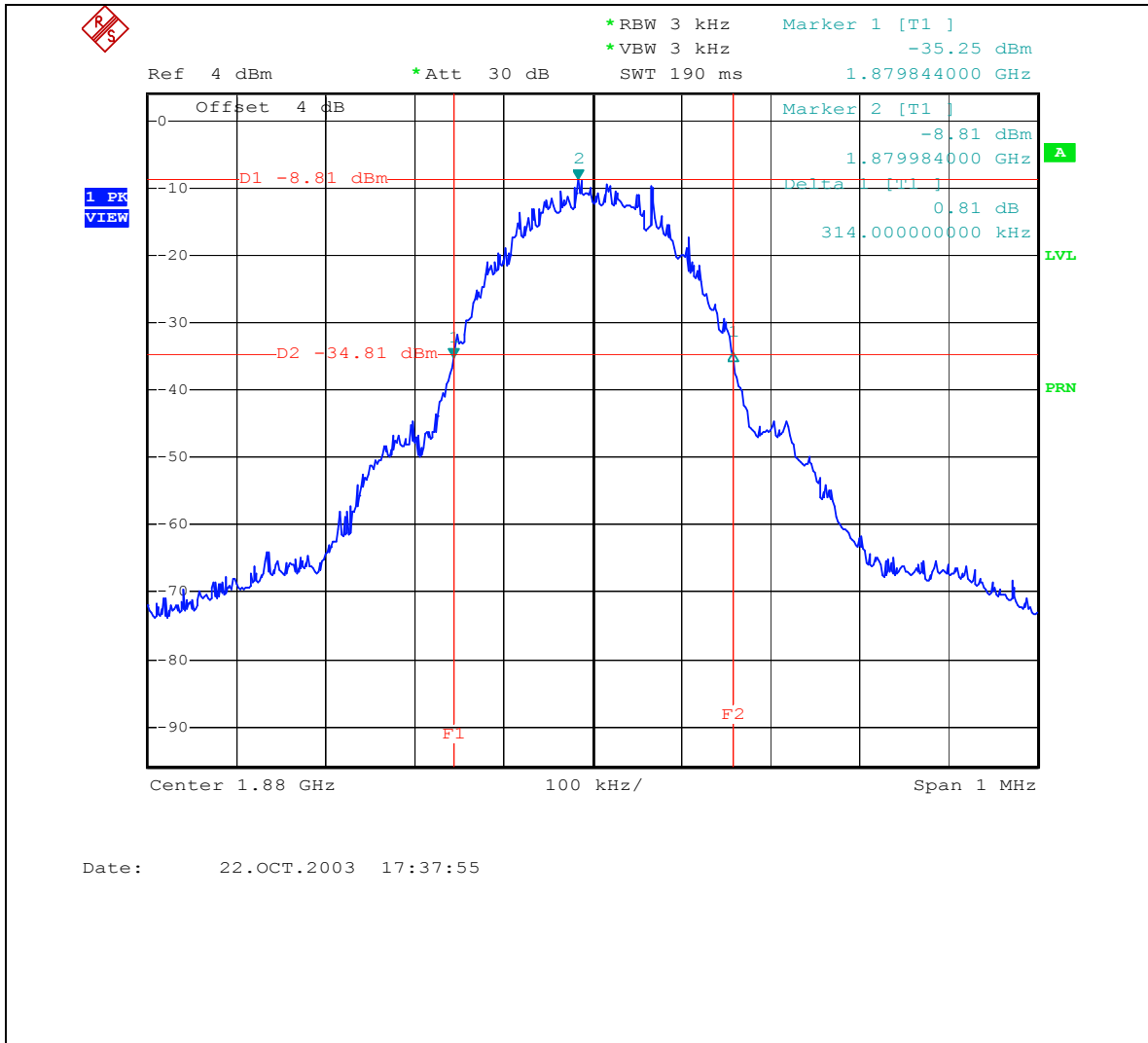

Channel 810 Max. Power -26 dBc Bandwidth

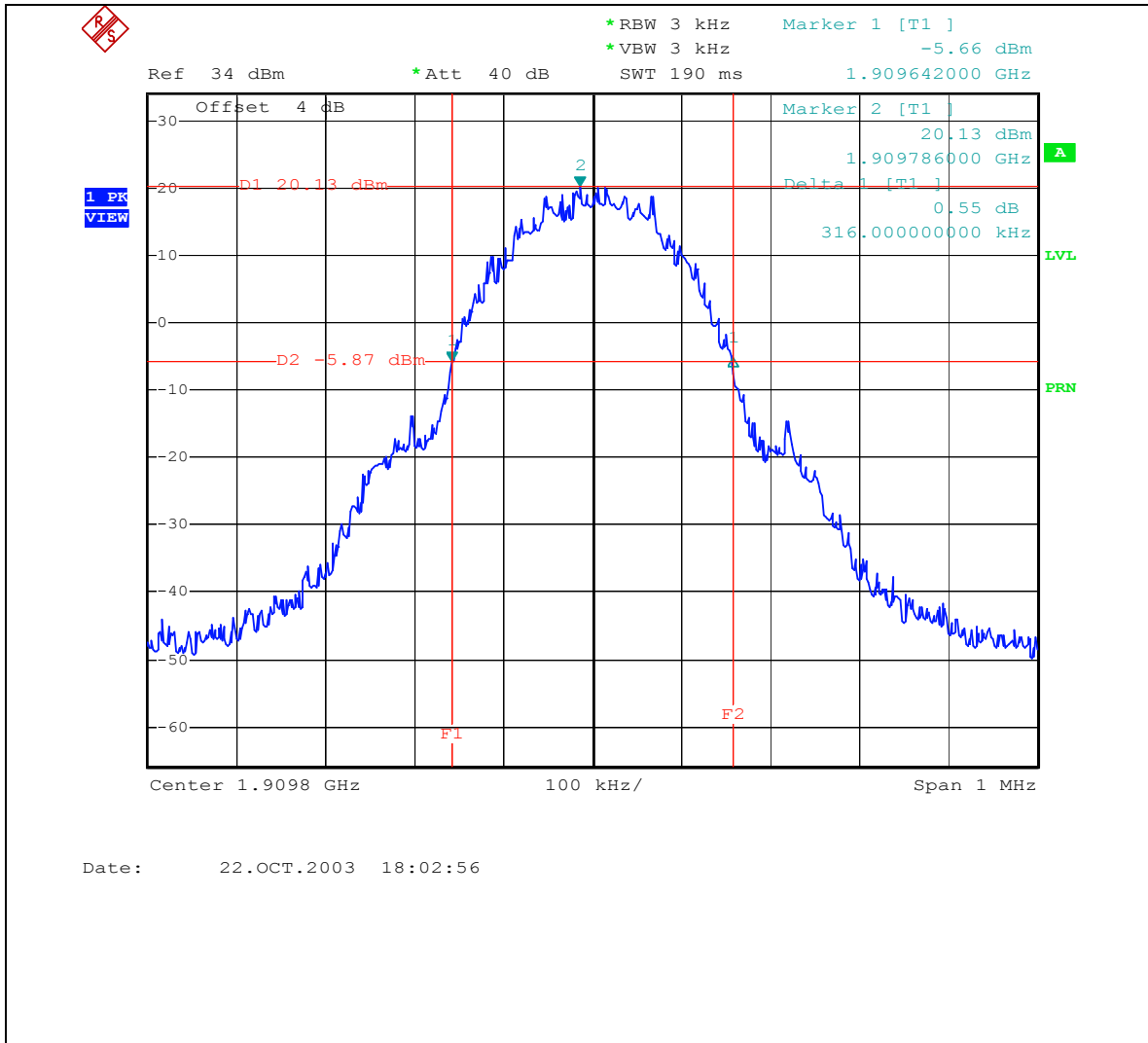

Channel 810 Min. Power -26 dBc Bandwidth

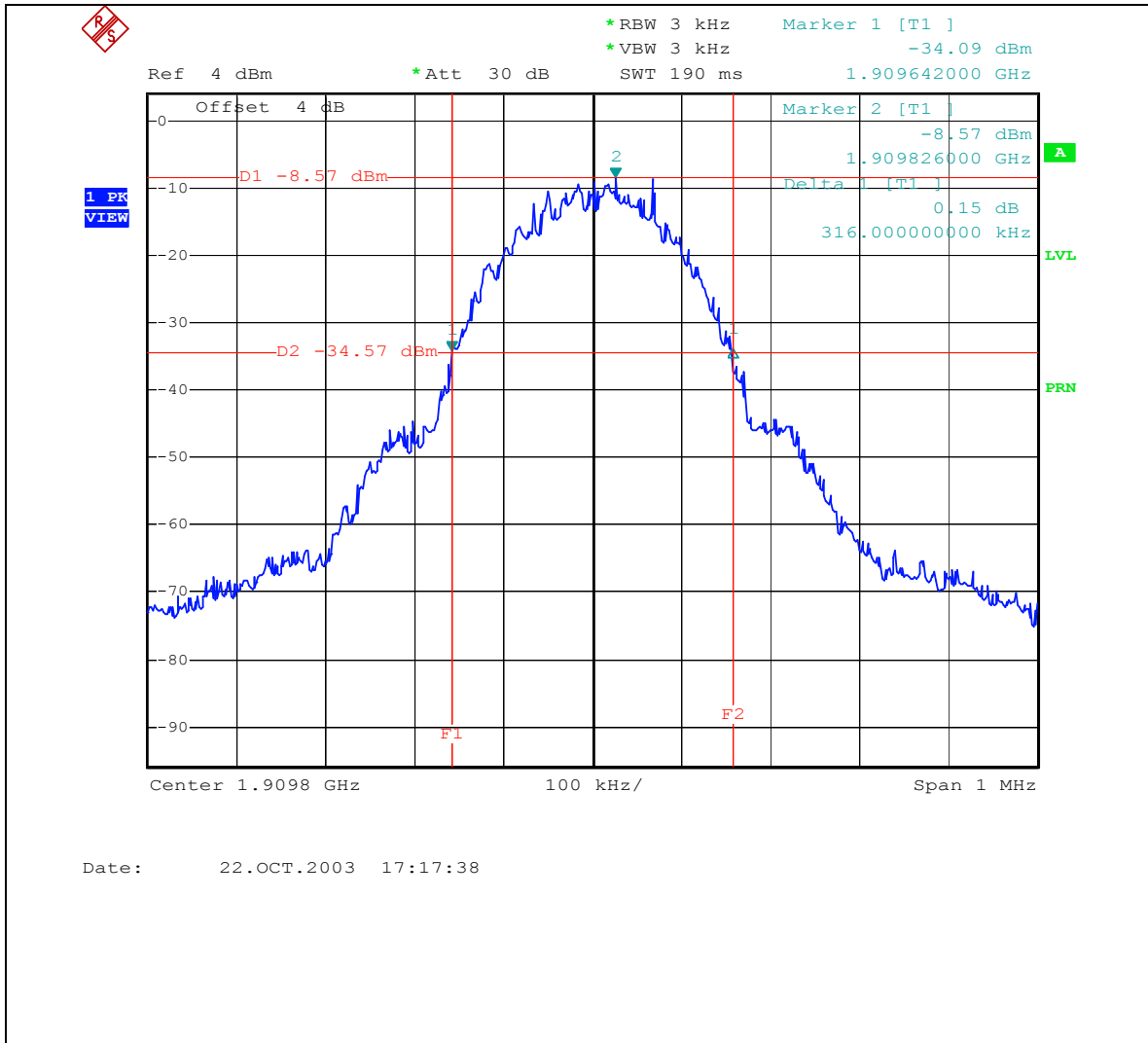

4.5 BAND EDGE MEASUREMENT

4.5.1 LIMITS OF BAND EDGE MEASUREMENT

The PCS frequency bands refer to the FCC 24.229 rule. According to FCC 24.238(b) specified that emission bandwidth is defined as the width of the signal between two points, one below the carrier center frequency and one above the carrier center frequency, outside of which all emissions are attenuated at least 26 dB below the transmitter power. In the 1 MHz bands immediately outside and adjacent to the frequency block a resolution bandwidth of at least one percent of the emission bandwidth of the fundamental emission of the transmitter may be employed. Then we measure that the bandwidth is about 300kHz and the resolution bandwidth is 3kHz.

4.5.2 TEST INSTRUMENTS

DESCRIPTION & MANUFACTURER	MODEL NO.	SERIAL NO.	CALIBRATED UNTIL
* ROHDE & SCHWARZ Spectrum Analyzer	FSP40	100035	Apr. 15, 2004
* ROHDE & SCHWARZ Universal Radio Communication Tester	CMU200	836072/086	Apr. 21, 2004
* Mini-Circuits Power Splitter	ZAPD-4	400005	NA
* Hewlett Packard RF cable	8120-6192	01428251	NA
* JFW 20dB attenuation	50HF-020-SMA	NA	NA
* Suhner RF cable	Sucoflex104	204850/4	NA

- NOTE:** 1. The calibration interval of the above test instruments is 12 months. And the calibrations are traceable to NML/ROC and NIST/USA.
 2. "*" = These equipments are used for the final measurement.

4.5.3 TEST SETUP

Same as Item 4.2.4 (Conducted Power Setup)

4.5.4 TEST PROCEDURES

- a. The EUT was set up for the maximum peak power with GPRS link data modulation. The power was measured with R&S Spectrum Analyzer. All measurements were done at 2 channels, 512 and 810(low and high operational frequency range.)
- b. The band edge measurement used the power splitter via EUT RF power connector between simulation base station and spectrum analyzer. This splitter loss and cable loss are the worst loss 4dB in the transmitted path track.
- c. The center frequency of spectrum is the band edge frequency and span is 2 MHz. RB and VB of the spectrum is 3kHz.
- d. Record the max trace plot into the test report.

4.5.5 EUT OPERATING CONDITION

- a. The EUT makes a phone call to the GSM simulator.
- b. The GSM simulator station system controlled a EUT to export maximum output power under transmission mode and specific channel frequency Same as Item 4.4.5.

4.5.6 TEST RESULTS

Lower Band Edge

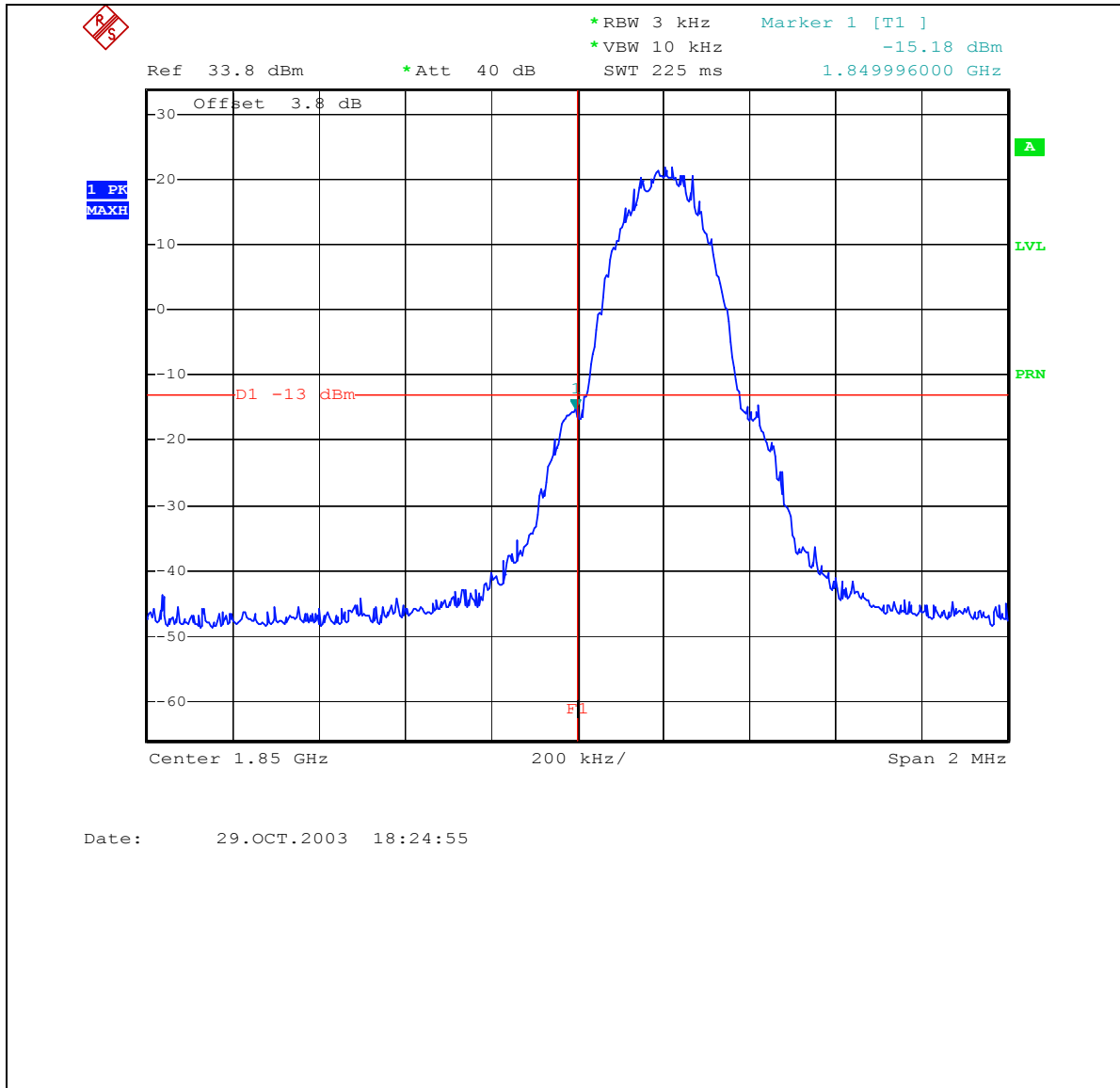

Higher Band Edge

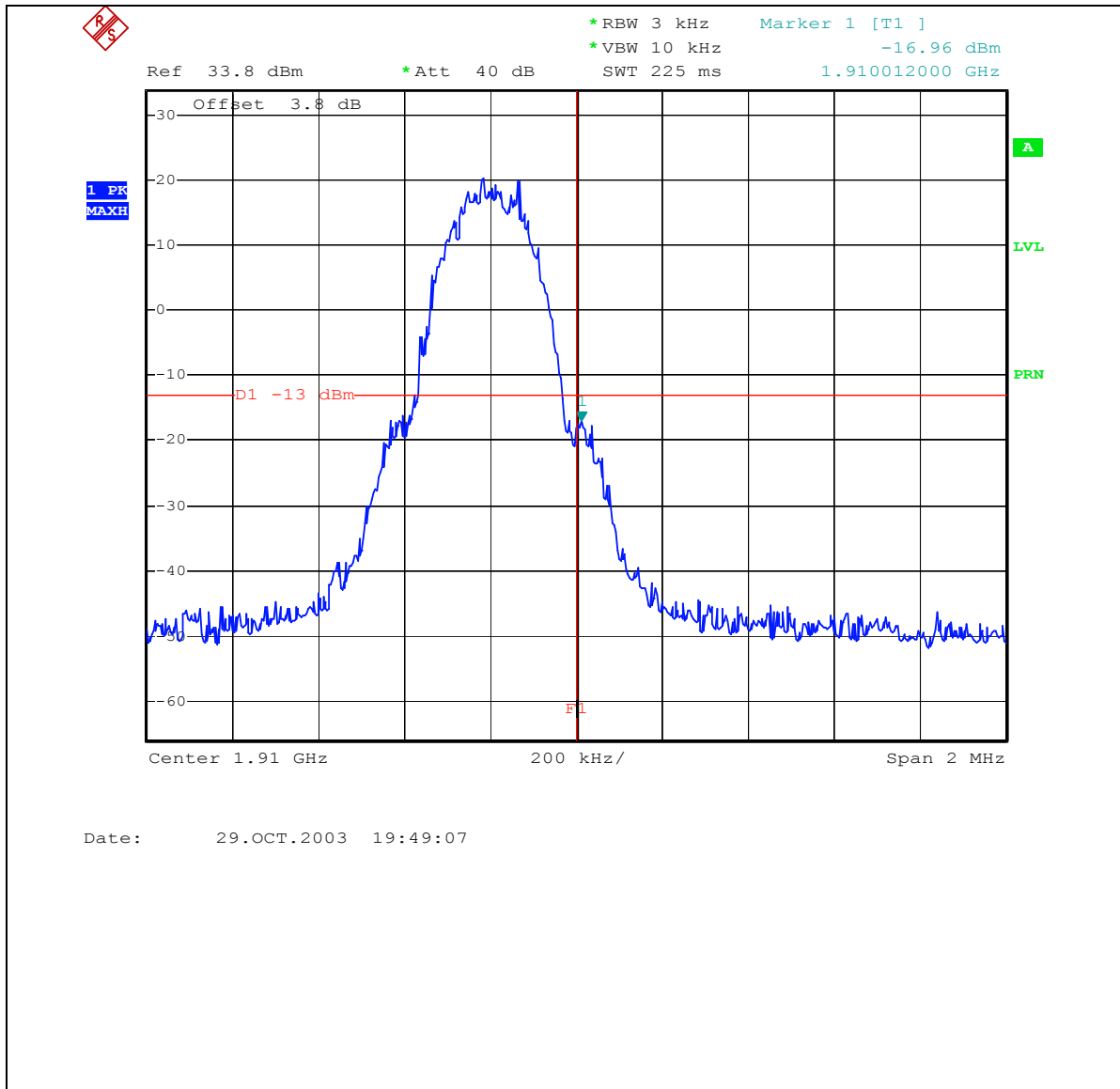

4.6 CONDUCTED SPURIOUS EMISSIONS

4.6.1 LIMITS OF CONDUCTED SPURIOUS EMISSIONS MEASUREMENT

In the FCC 24.238(a), On any frequency outside a licensee's frequency block within USPCS spectrum, the power of any emission shall be attenuated below the transmitter power (P) by at least $43 + 10 \log (P)$ dB. The limit translates in the relevant power range (1 to 0.001W). At 1W(Power Control Level 0) the specified minimum attenuation becomes 43dB and the limit of emission equal to -13dBm . At 0.001W(Power Control Level 15) the specified minimum attenuation becomes 13dB and the emission of limit equal to -13dBm . So the limit of emission is the same absolute specified line. In the FCC 24.238(c), When measuring the emission limits, the nominal carrier frequency shall be adjusted as close to the licensee's frequency block edges (low channel 512 and high channel 810), both upper and lower edges are compliance with FCC 24.238(b), Adjacent to the frequency block a resolution bandwidth of at least one percent of the emission bandwidth of the fundamental emission of the transmitter may be employed.

4.6.2 TEST INSTRUMENTS

DESCRIPTION & MANUFACTURER	MODEL NO.	SERIAL NO.	CALIBRATED UNTIL
* ROHDE & SCHWARZ Spectrum Analyzer	FSP40	100035	Apr. 15, 2004
* ROHDE & SCHWARZ Signal Generator	SMP04	10001	May 05, 2004
* ROHDE & SCHWARZ Universal Radio Communication Tester	CMU200	836072/086	Apr. 21, 2004
* Wainwright Instruments Band Reject Filter	WRCG1850/1910- 1830/1930- 60/10SS	SN1	NA
* Wainwright Instruments High Pass Filter	WHK3.1/18G-10SS	SN1	NA
* Mini-Circuits Power Splitter	ZAPD-4	400005	NA
* Hewlett Packard RF cable	8120-6192	01428251	NA
* JFW 20dB attenuation	50HF-020-SMA	NA	NA
* Suhner RF cable	Sucoflex104	204850/4	NA

- NOTE:** 1. The calibration interval of the above test instruments is 12 months. And the calibrations are traceable to NML/ROC and NIST/USA.
 2. "*" = These equipments are used for the final measurement.

4.6.3 TEST PROCEDURE

- a. The EUT was set up for the maximum peak power with GPRS link data modulation. The power was measured with R&S Spectrum Analyzer. All measurements were done at 3 channels, 512, 661 and 810(low, middle and high operational frequency range.)
- b. The conducted spurious emission used the power splitter via EUT RF power connector between simulation base station and spectrum analyzer. This splitter loss and cable loss are the worst loss 4dB in the transmitted path track.
- c. When the spectrum scanned from 9kHz to 3GHz, it shall be connected to the band reject filter attenuated the carried frequency. The spectrum set RB/VB 1MHz.
- d. When the spectrum scanned from 3kHz to 20GHz, it shall be connected to the high pass filter attenuated the carried frequency. The spectrum set RB/VB 1MHz.

4.6.4 TEST SETUP

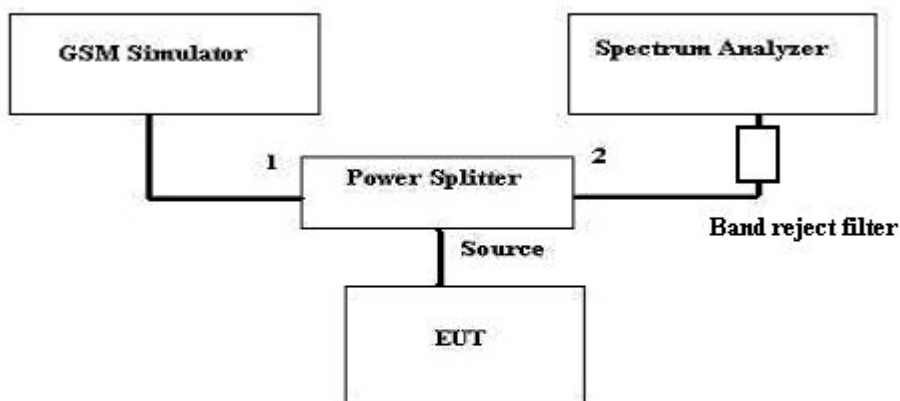

4.6.5 EUT OPERATING CONDITIONS

- a. The EUT makes a phone call to the GSM simulator.
- b. The GSM simulator station system controlled a EUT to export maximum output power under transmission mode and specific channel frequency.

4.6.6 TEST RESULTS

Channel 512 9kHz~3GHz

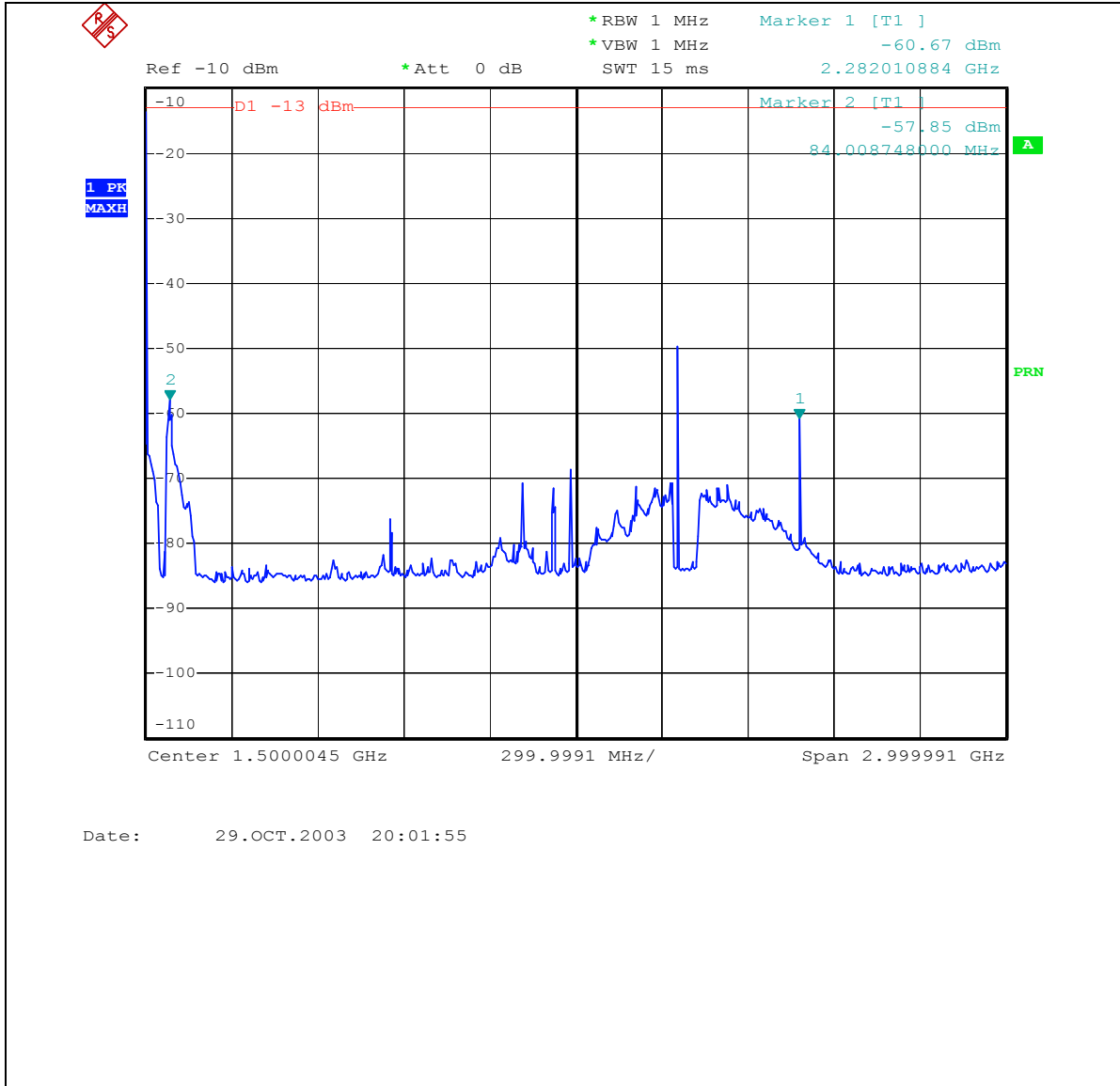

Channel 512 3GHz~10GHz

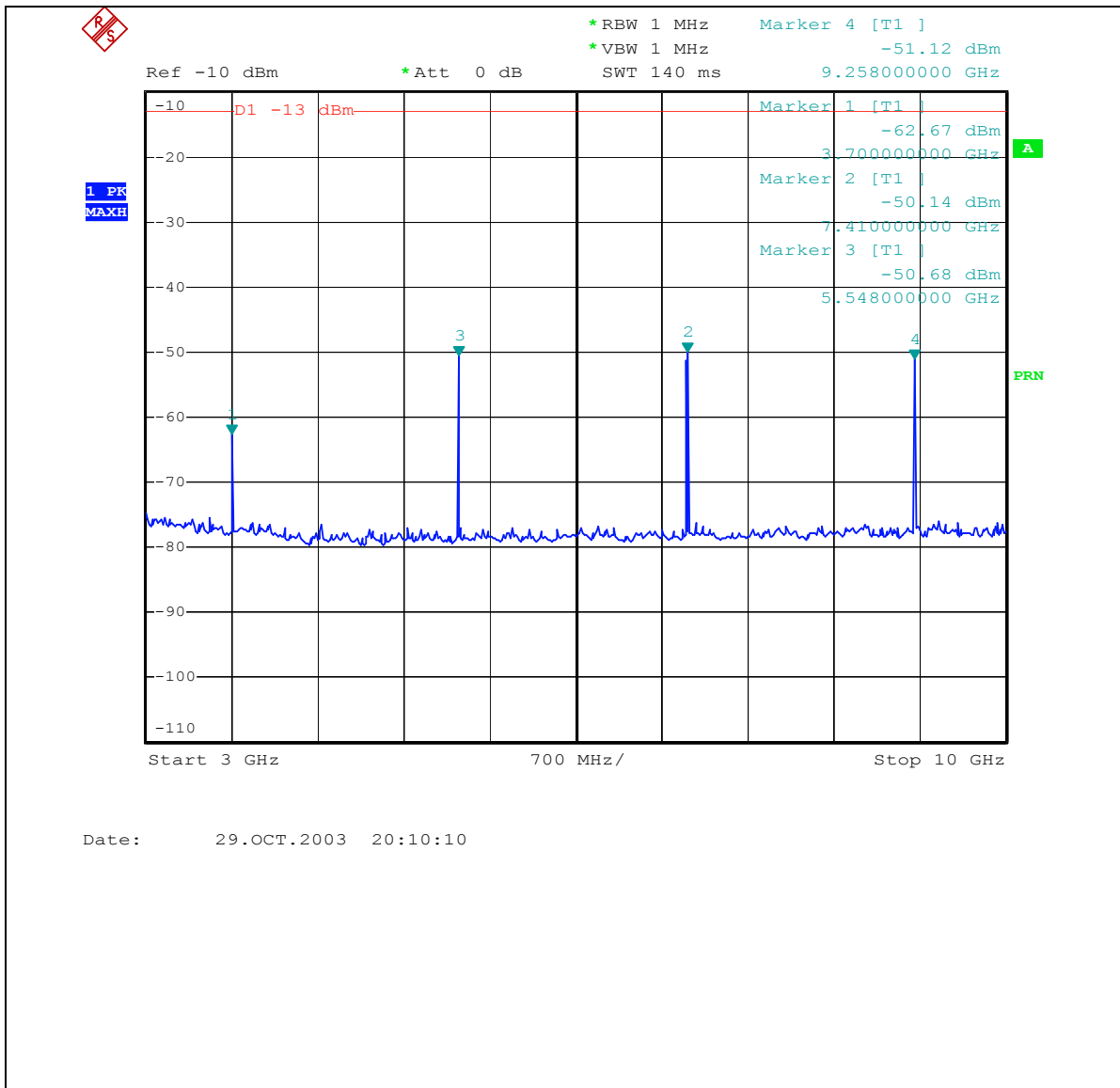

Channel 512 10GHz~20GHz

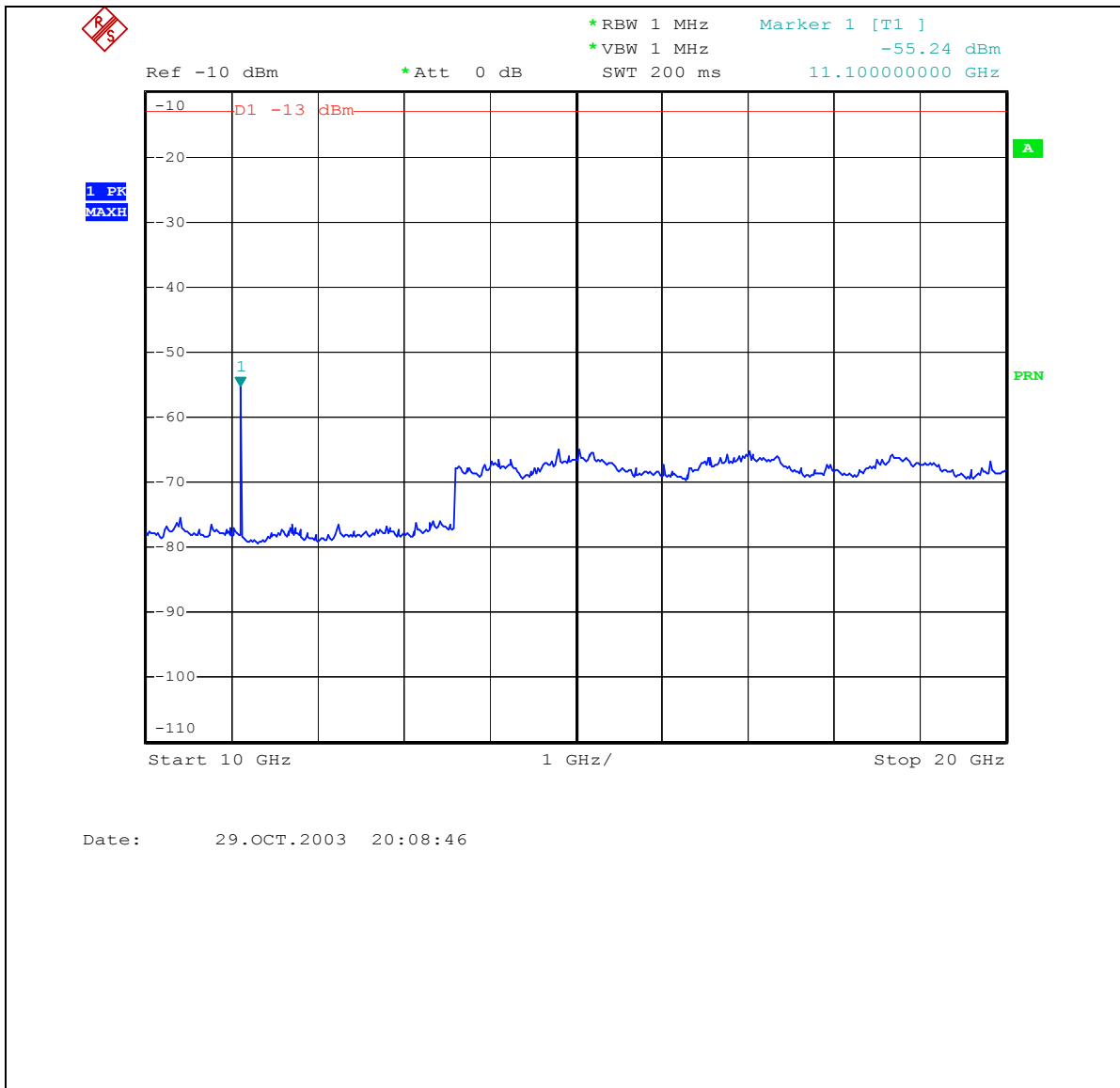

Channel 661 9kHz~3GHz

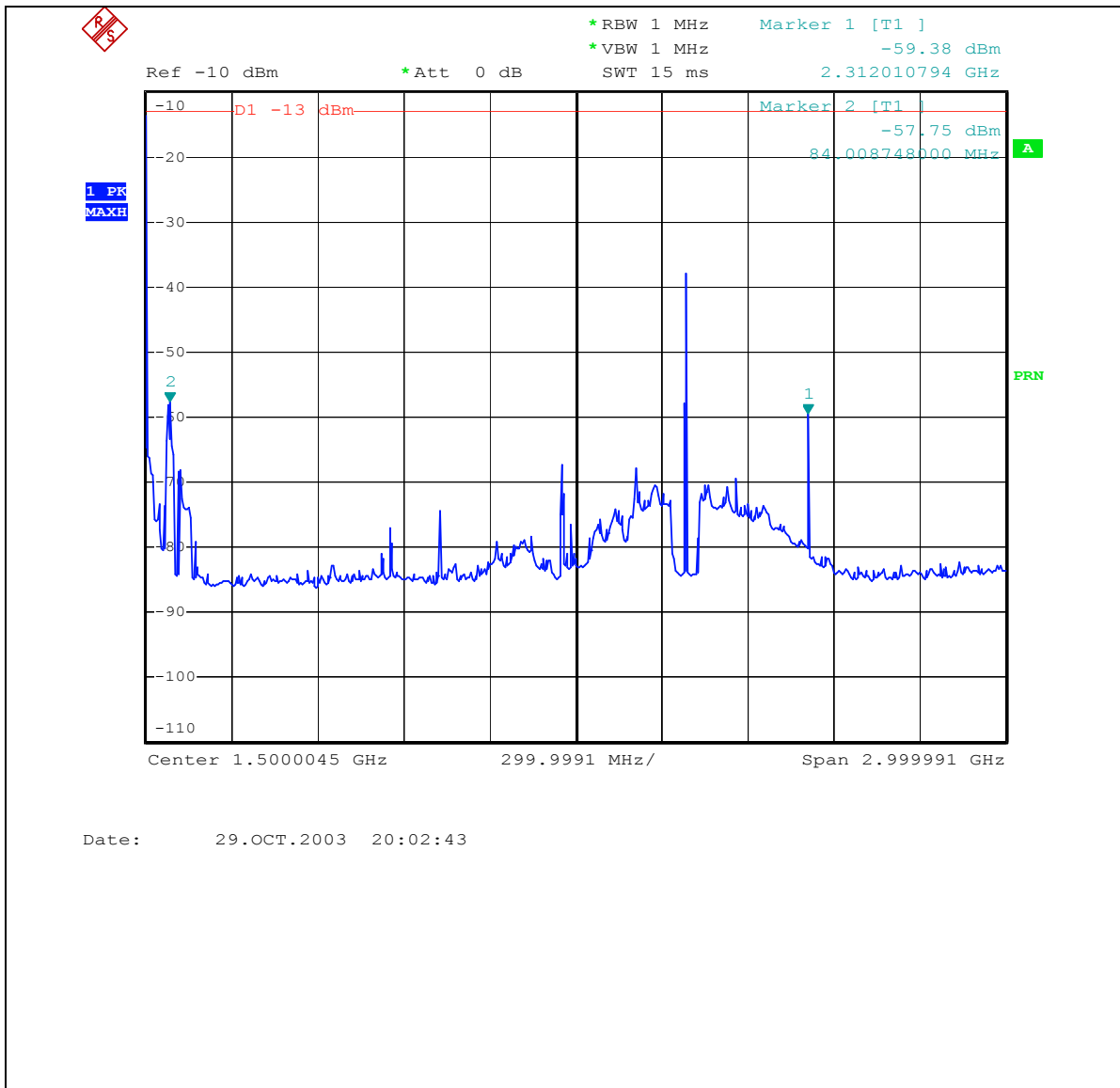

Channel 661 3GHz~10GHz

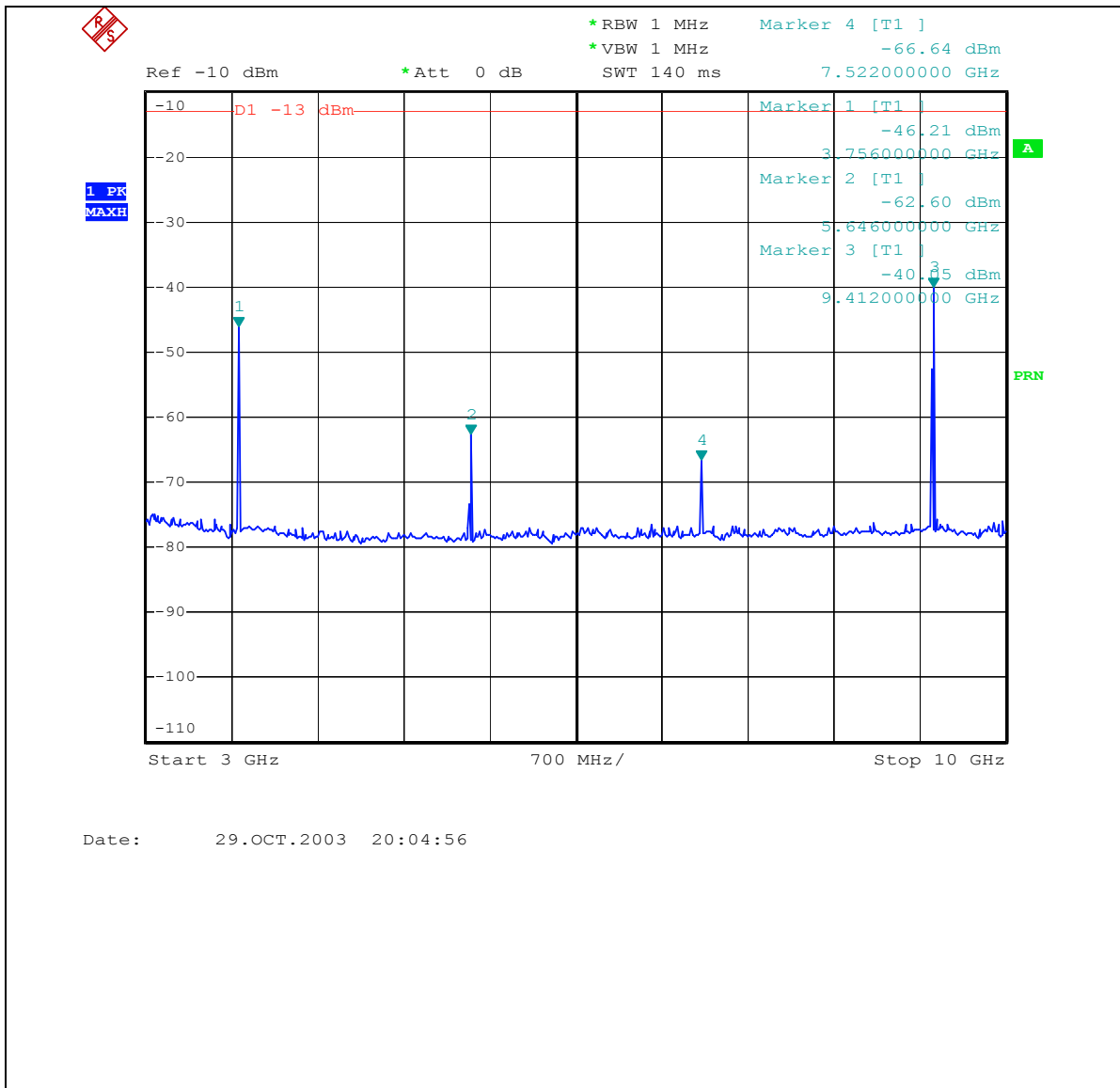

Channel 661 10GHz~20GHz

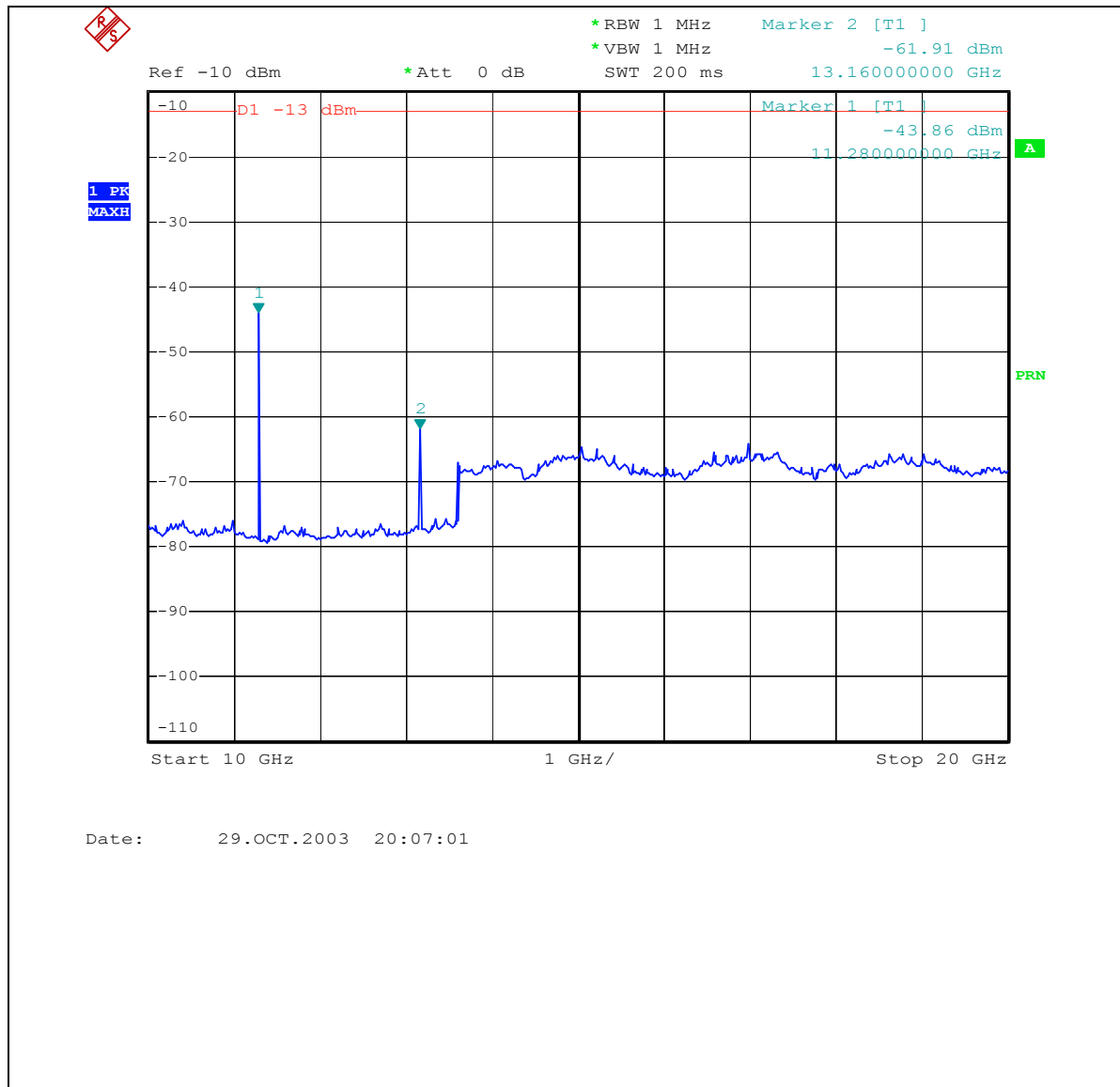

Channel 810 9kHz~3GHz

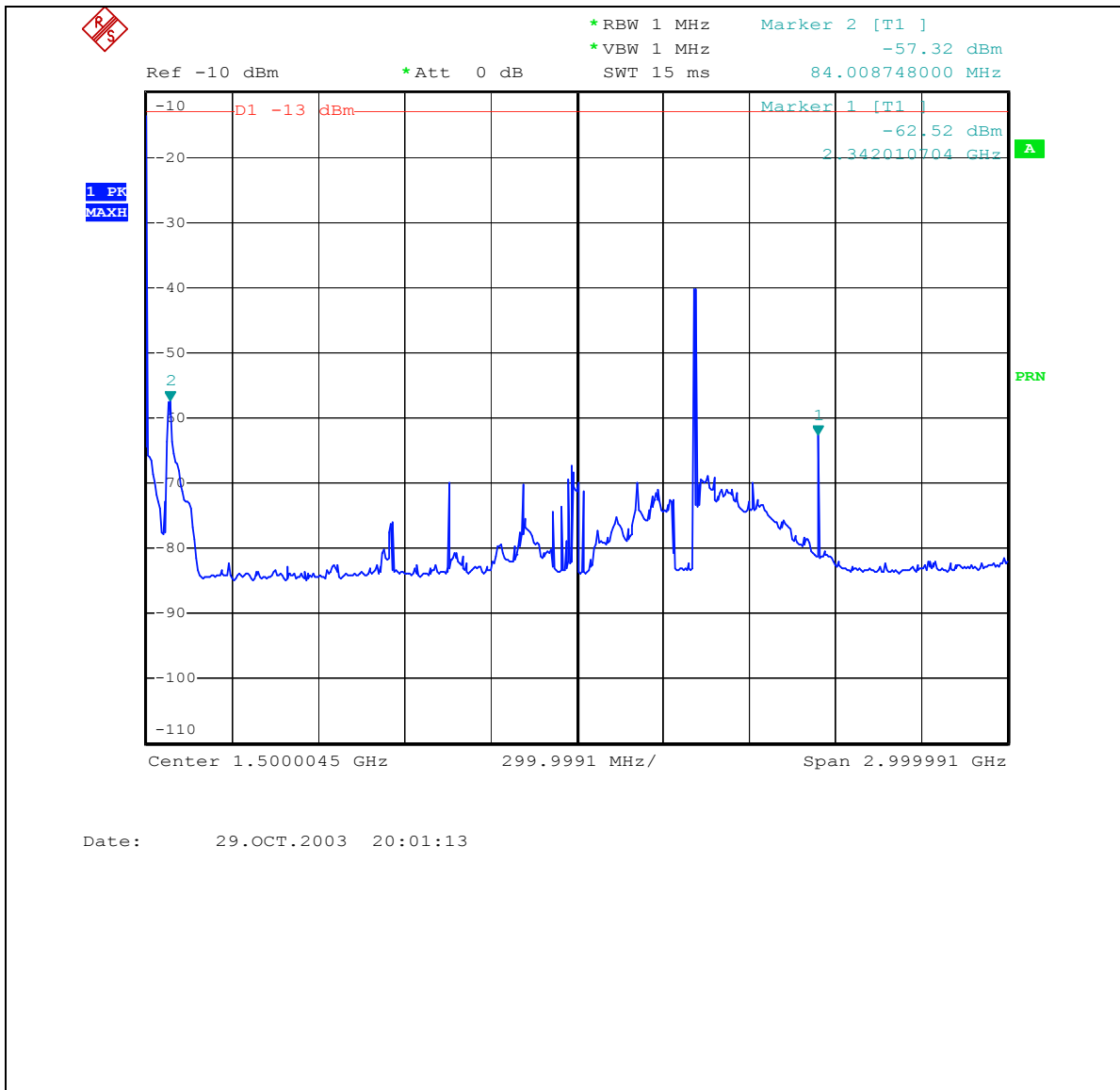

Channel 810 3GHz~10GHz

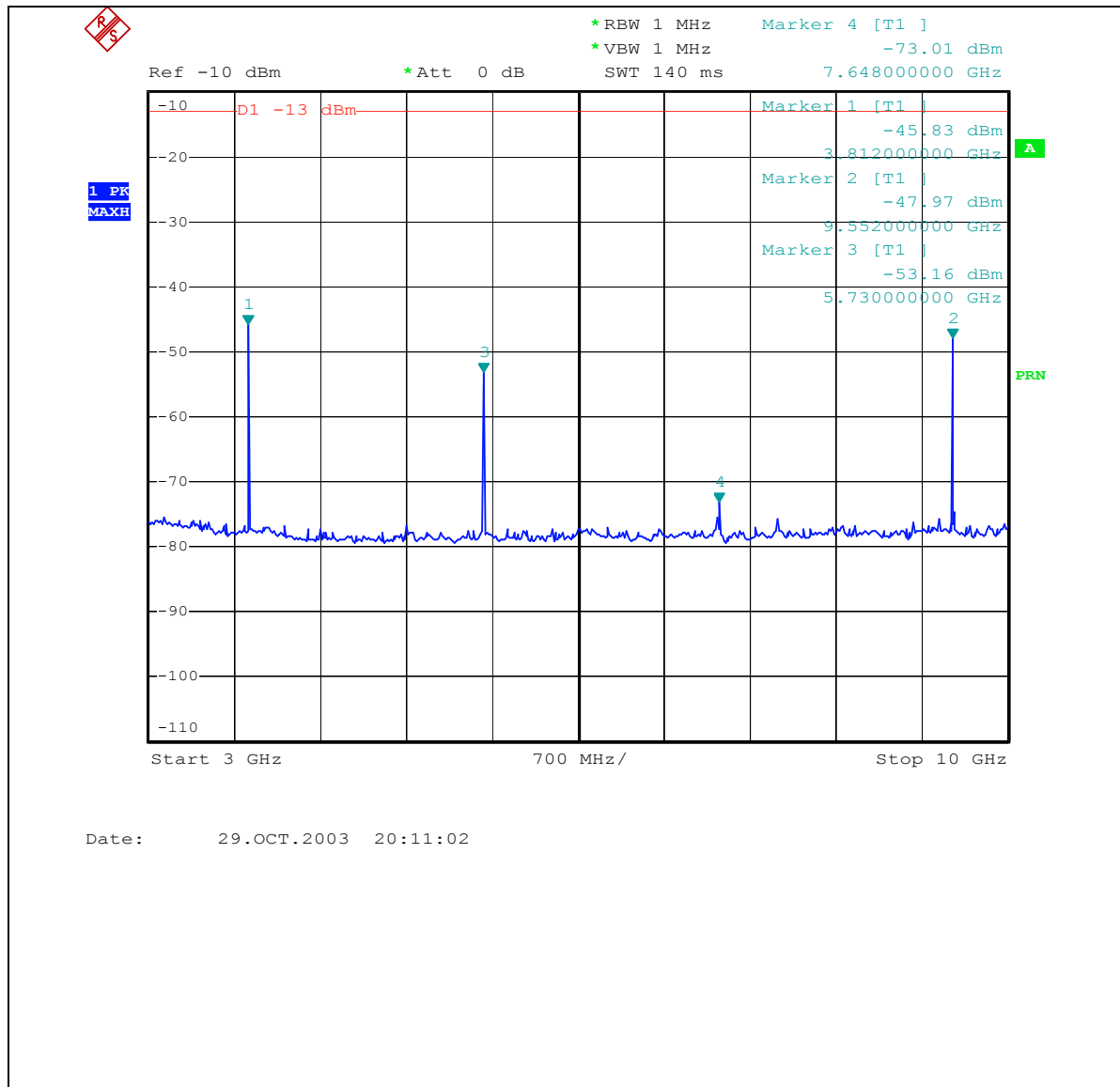

Channel 810
10GHz~20GHz

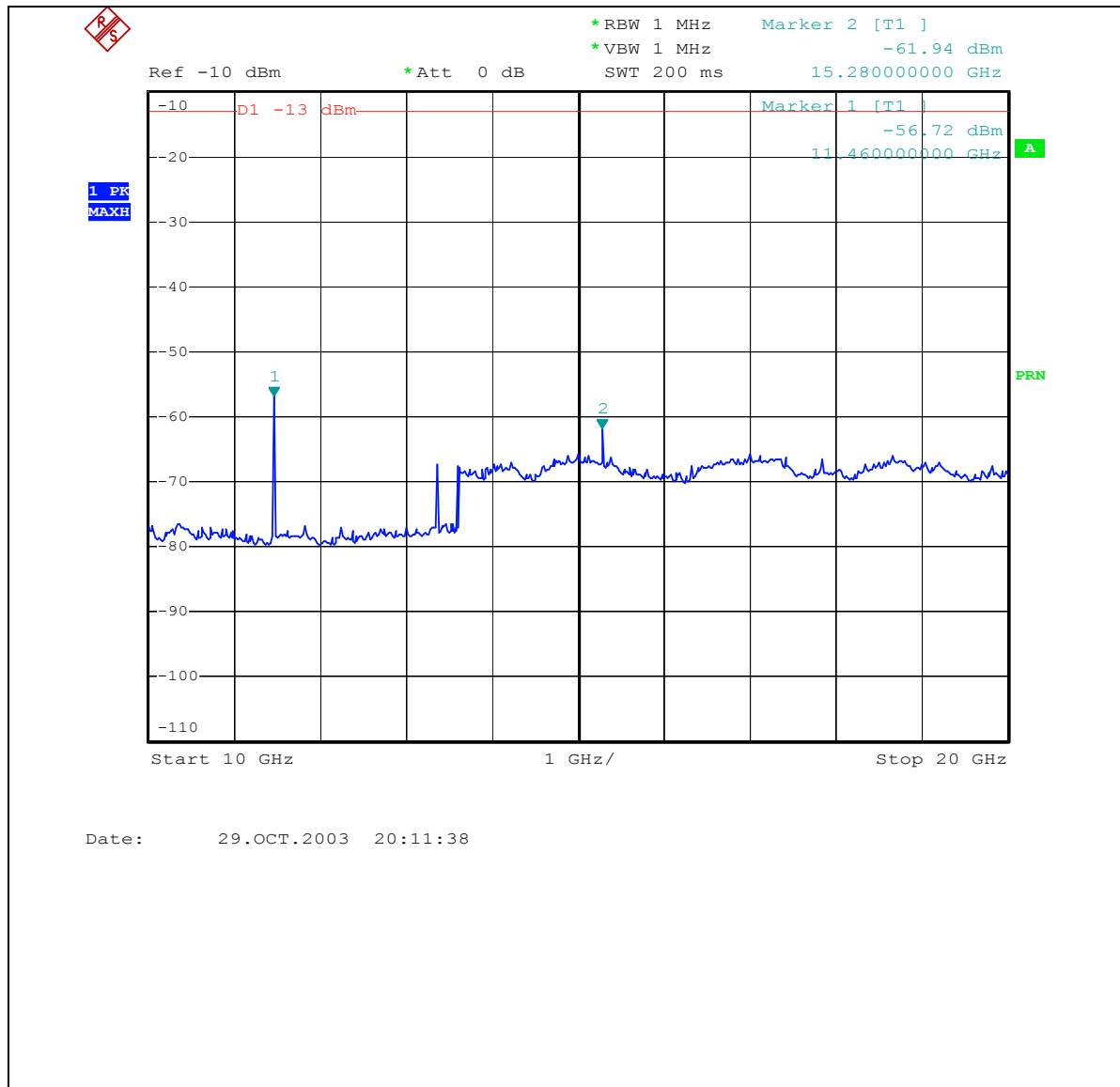

EUT	Smartphone	MODEL	P30 (57P30), BenQ P30
MODE	Tx Channel 512	POWER CONTROL LEVEL	0
INPUT POWER (SYSTEM)	120Vac, 60 Hz	DETECTOR FUNCTION	Peak
ENVIRONMENTAL CONDITIONS	26 deg. C, 78 % RH, 991 hPa	TESTED BY: Bunny Yao	

CONDUCTED SPURIOUS EMISSION					
Frequency (MHz)	Raw (dBm)	Correction Factor(dB)	Conducted Level(dBm)	Limit (dBm)	Margin
3700	-62.67	3.94	-58.73	-13.00	-45.73
5548	-50.68	4.44	-46.24	-13.00	-33.24
7410	-50.14	4.12	-46.02	-13.00	-33.02
9258	-51.12	4.33	-46.79	-13.00	-33.79
11100	-55.24	4.54	-50.70	-13.00	-37.70

REMARKS:

1. Peak Output Power(dBm)=Raw Value(dBm) + Correction Factor(dB)
2. Correction Factor(dB) = Power Splitter Loss(dB) + Cable Loss(dB)

EUT	Smartphone	MODEL	P30 (57P30), BenQ P30
MODE	Tx Channel 661	POWER CONTROL LEVEL	0
INPUT POWER (SYSTEM)	120Vac, 60 Hz	DETECTOR FUNCTION	Peak
ENVIRONMENTAL CONDITIONS	26 deg. C, 78 % RH, 991 hPa	TESTED BY: Bunny Yao	

CONDUCTED SPURIOUS EMISSION					
Frequency (MHz)	Raw (dBm)	Correction Factor(dB)	Conducted Level(dBm)	Limit (dBm)	Margin
3756	-46.21	3.99	-42.22	-13.00	-29.22
5646	-62.60	4.18	-58.42	-13.00	-45.42
7522	-66.64	4.33	-62.31	-13.00	-49.31
9412	-40.05	4.46	-35.59	-13.00	-22.59
11280	-43.86	4.57	-39.29	-13.00	-26.29
13160	-61.91	4.68	-57.23	-13.00	-44.23

REMARKS:

1. Peak Output Power(dBm)=Raw Value(dBm) + Correction Factor(dB)
2. Correction Factor(dB) = Power Splitter Loss(dB) + Cable Loss(dB)

EUT	Smartphone	MODEL	P30 (57P30), BenQ P30
MODE	Tx Channel 810	POWER CONTROL LEVEL	0
INPUT POWER (SYSTEM)	120Vac, 60 Hz	DETECTOR FUNCTION	Peak
ENVIRONMENTAL CONDITIONS	26 deg. C, 78 % RH, 991 hPa	TESTED BY: Bunny Yao	

CONDUCTED SPURIOUS EMISSION					
Frequency (MHz)	Raw (dBm)	Correction Factor(dB)	Conducted Level(dBm)	Limit (dBm)	Margin
3812	-45.83	4.00	-41.83	-13.00	-28.83
5730	-53.16	4.16	-49.00	-13.00	-36.00
7648	-73.01	4.45	-68.56	-13.00	-55.56
9552	-47.97	4.28	-43.69	-13.00	-30.69
11460	-56.72	4.58	-52.14	-13.00	-39.14
15280	-61.94	4.70	-57.24	-13.00	-44.24

REMARKS:

1. Peak Output Power(dBm)=Raw Value(dBm) + Correction Factor(dB)
2. Correction Factor(dB) = Power Splitter Loss(dB) + Cable Loss(dB)

4.7 RADIATED EMISSION MEASUREMENT

4.7.1 LIMITS OF RADIATED EMISSION MEASUREMENT

In the FCC 24.238(a), On any frequency outside a licensee's frequency block within USPCS spectrum, the power of any emission shall be attenuated below the transmitter power (P) by at least $43 + 10 \log (P)$ dB. The limit translates in the relevant power range (1 to 0.001W). At 1W(Power Control Level 0) the specified minimum attenuation becomes 43dB and the limit of emission equal to -13dBm . At 0.001W(Power Control Level 15) the specified minimum attenuation becomes 13dB and the emission of limit equal to -13dBm . So the limit of emission is the same absolute specified line.

4.7.2 TEST INSTRUMENTS

DESCRIPTION & MANUFACTURER	MODEL NO.	SERIAL NO.	CALIBRATED UNTIL
* HP Preamplifier	8447D	2432A03504	Jun. 10, 2004
* HP Preamplifier	8449B	3008A01201	Dec. 01, 2003
* HP Preamplifier	8449B	3008A01638	Oct. 17, 2004
SCHAFFNER Tunable Dipole Antenna	VHBA 9123	459	Nov. 22, 2003
SCHWARZBECK Tunable Dipole Antenna	UHA 9105	977	
* ROHDE & SCHWARZ TEST RECEIVER	ESMI	839013/007 839379/002	Feb. 13, 2004
Schwarzbeck Antenna	VULB9168	137	Apr. 03, 2004
* SCHWARZBECK Horn Antenna	BBHA9120-D1	D130	Jun. 30, 2004
* EMCO Horn Antenna	3115	9312-4192	Mar. 23 2004
ADT. Turn Table	TT100	0306	NA
ADT. Tower	AT100	0306	NA
Software	ADT_Radiated_V 5.14	NA	NA
TIMES RF cable	LL142	CABLE-CH6-01	Apr. 30, 2004
* Wainwright Instruments Band Reject Filter	WRCG1850/1910- 1830/1930-60/10SS	SN1	NA
* Wainwright Instruments High Pass Filter	WHK3.1/18G-10SS	SN1	NA

- NOTE:**
1. The calibration interval of the above test instruments is 12 months. And the calibrations are traceable to NML/ROC and NIST/USA.
 2. "*" = These equipment are used for the final measurement.
 3. The horn antenna and HP preamplifier (model: 8449B) are used only for the measurement of emission frequency above 1GHz if tested.
 4. The test was performed in ADT Chamber No. 6.

4.7.3 TEST PROCEDURES

- a. The test site arranged for emission measurement. According to ANSI C63.4-2001 requirement and conformed by the FCC to comply with for 3 m and 10 m site. The spectrum calibrated from 30MHz to 10th harmonic of the carried frequency.
- b. The highest carried frequency is 1910MHz. Therefore the frequency spectrum scanned up to 20GHz. The resolution bandwidth is set as outline in Part 24.238(b) compliance with these provisions is based on the use of measurement instrumentation employing a resolution bandwidth of 1 MHz or greater.
- c. The spectrum scanned carried frequencies assign to USPCS mobile station transmitting carried frequency block that pertain to low, mid and high channels.
- d. The EUT was set 3 meters away from the receiving antenna, which was mounted on the top of a variable-height antenna tower.
- e. When spectrum scanned between 30MHz~1GHz. The receiver antenna is a broadband antenna, and its height is varied from one meter to four meters above the ground to determine the maximum value of the field strength. Both horizontal and vertical polarizations of the antenna are set to make the measurement. A spectrum scanned above 1GHz to replace a double-ridged wave-guide horn antenna.
- f. For each suspected emission, the EUT was arranged to its worst case and then the antenna was tuned to heights from 1 meter to 4 meters and the rotated table was turned from 0 degrees to 360 degrees to find the maximum reading.
- g. The test-receiver system was set to Peak Detect Function and Specified Bandwidth with Maximum Hold Mode. If the harmonic could not be detected above the noise floor, the ambient level was recorded.
- h. The level of the carrier measured on each channel is shown below:

The E-field strength at 1850.2MHz(Channel 512)=126.45 dB μ V/m

Therefore the limits is $126.45-(43+10\log(1.0))=126.45-43=83.45$ dB μ V/m

The E-field strength at 1880.0MHz(Channel 661)=126.27 dB μ V/m

Therefore the limits is $126.27-(43+10\log(1.0))= 126.27-43=83.27$ dB μ V/m

The E-field strength at 1909.8MHz(Channel 810)=127.81 dB μ V/m

Therefore the limits is $127.81-(43+10\log(1.0))= 127.81-43=84.81$ dB μ V/m

4.7.4 TEST SETUP

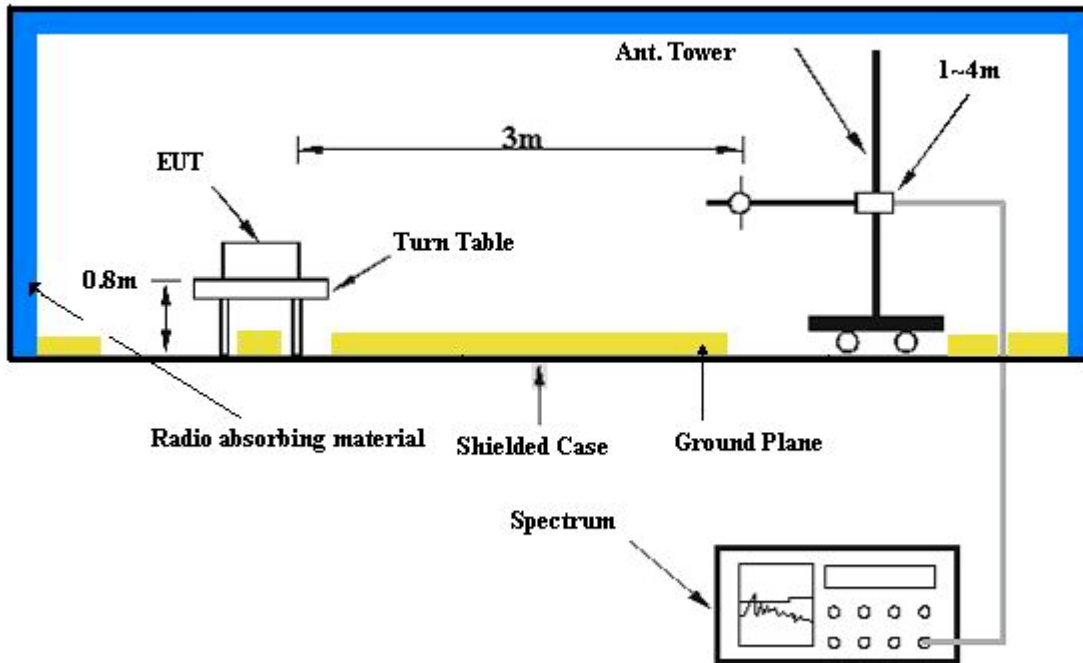

For the actual test configuration, please refer to the related item – Photographs of the Test Configuration.

4.7.5 EUT OPERATING CONDITIONS

- a. The EUT makes a phone call to the GSM simulator.
- b. The GSM simulator station system controlled a EUT to export maximum output power under transmission mode and specific channel frequency.
- c. Test position



E1 plane

E2 plane

H plane

4.7.6 TEST RESULTS

EUT	Smartphone	MODEL	P30 (57P30), BenQ P30
MODE	TX connected Ch.512 H plane	FREQUENCY RANGE	Below 1000 MHz
INPUT POWER (SYSTEM)	120Vac, 60 Hz	DETECTOR FUNCTION	Quasi-Peak
ENVIRONMENTAL CONDITIONS	26 deg. C, 78 % RH, 991 hPa	TESTED BY: Steven Lu	

ANTENNA POLARITY & TEST DISTANCE: VERTICAL AT 3 M								
No.	Freq. (MHz)	Emission Level (dBuV/m)	Limit (dBuV/m)	Margin (dB)	Antenna Height (m)	Table Angle (Degree)	Raw Value (dBuV)	Correction Factor (dB/m)
1	57.21	32.31 QP	83.45	-51.14	1.00 V	79	18.93	13.38
2	179.68	27.86 QP	83.45	-55.59	1.00 V	28	15.33	12.53
3	189.40	23.52 QP	83.45	-59.93	1.00 V	310	11.63	11.88
4	239.94	25.53 QP	83.45	-57.92	1.00 V	52	12.36	13.17
5	372.12	28.53 QP	83.45	-54.92	1.50 V	25	11.54	16.99
6	412.95	29.24 QP	83.45	-54.21	1.00 V	22	11.12	18.12
7	426.55	32.78 QP	83.45	-50.67	1.00 V	31	14.23	18.55
8	473.21	28.05 QP	83.45	-55.40	1.00 V	340	8.42	19.63
9	533.47	35.43 QP	83.45	-48.02	1.00 V	10	14.68	20.75
10	539.30	39.13 QP	83.45	-44.32	1.00 V	10	18.24	20.88
11	547.07	33.94 QP	83.45	-49.51	1.00 V	13	12.88	21.06
12	599.56	30.53 QP	83.45	-52.92	1.00 V	340	7.95	22.59
13	673.43	32.81 QP	83.45	-50.64	1.50 V	352	9.22	23.59
14	720.08	36.31 QP	83.45	-47.14	1.50 V	25	11.78	24.53

ANTENNA POLARITY & TEST DISTANCE: HORIZONTAL AT 3 M								
No.	Freq. (MHz)	Emission Level (dBuV/m)	Limit (dBuV/m)	Margin (dB)	Antenna Height (m)	Table Angle (Degree)	Raw Value (dBuV)	Correction Factor (dB/m)
1	43.61	20.53 QP	83.45	-62.92	2.00 H	136	6.03	14.50
2	239.94	23.13 QP	83.45	-60.32	1.50 H	313	9.95	13.17
3	366.29	25.39 QP	83.45	-58.06	1.00 H	328	8.55	16.84
4	479.04	27.24 QP	83.45	-56.21	1.50 H	310	7.53	19.71
5	533.47	33.22 QP	83.45	-50.23	1.50 H	304	12.47	20.75
6	539.30	36.22 QP	83.45	-47.23	1.50 H	313	15.34	20.88
7	547.07	32.28 QP	83.45	-51.17	1.50 H	325	11.22	21.06
8	593.73	26.38 QP	83.45	-57.07	1.50 H	313	3.97	22.41
9	659.82	28.42 QP	83.45	-55.03	2.50 H	316	5.03	23.39
10	667.60	28.54 QP	83.45	-54.91	2.50 H	277	5.03	23.51

REMARKS:

1. Emission level(dBuV/m)=Raw Value(dBuV) + Correction Factor(dB)
2. Correction Factor(dB/m) = Antenna Factor (dB/m) + Cable Factor (dB)
3. The other emission levels were very low against the limit.
4. Margin value = Emission level – Limit value.
5. This is valid for all 3 channels

EUT	Smartphone	MODEL	P30 (57P30), BenQ P30
MODE	TX connected Ch.512 E1 plane	FREQUENCY RANGE	Below 1000 MHz
INPUT POWER (SYSTEM)	120Vac, 60 Hz	DETECTOR FUNCTION	Quasi-Peak
ENVIRONMENTAL CONDITIONS	26 deg. C, 78 % RH, 991 hPa	TESTED BY: Steven Lu	

ANTENNA POLARITY & TEST DISTANCE: VERTICAL AT 3 M								
No.	Freq. (MHz)	Emission Level (dBuV/m)	Limit (dBuV/m)	Margin (dB)	Antenna Height (m)	Table Angle (Degree)	Raw Value (dBuV)	Correction Factor (dB/m)
1	57.21	33.41 QP	83.45	-51.14	1.00 V	91	20.03	13.38
2	179.68	28.56 QP	83.45	-54.89	1.00 V	241	16.03	12.53
3	239.94	24.24 QP	83.45	-59.21	1.00 V	79	11.07	13.17
4	366.29	25.72 QP	83.45	-57.73	1.50 V	319	8.88	16.84
5	393.51	24.85 QP	83.45	-58.6	1.50 V	238	7.31	17.54
6	426.55	27.97 QP	83.45	-55.48	1.50 V	97	9.41	18.55
7	445.99	31.26 QP	83.45	-52.19	1.50 V	31	12.09	19.17
8	453.77	30.42 QP	83.45	-53.03	1.00 V	31	11.06	19.35
9	473.21	33.39 QP	83.45	-50.06	1.50 V	127	13.76	19.63
10	480.98	32.11 QP	83.45	-51.34	1.00 V	325	12.37	19.74
11	533.47	27.14 QP	83.45	-56.31	1.00 V	130	6.39	20.75
12	539.30	29.32 QP	83.45	-54.13	1.00 V	124	8.44	20.88
13	599.56	31.48 QP	83.45	-51.97	1.50 V	358	8.90	22.59
14	613.17	30.21 QP	83.45	-53.24	1.50 V	358	7.44	22.77
15	673.43	27.93 QP	83.45	-55.52	1.00 V	16	4.34	23.59
16	720.08	29.80 QP	83.45	-53.65	1.00 V	37	5.27	24.53

ANTENNA POLARITY & TEST DISTANCE: HORIZONTAL AT 3 M								
No.	Freq. (MHz)	Emission Level (dBuV/m)	Limit (dBuV/m)	Margin (dB)	Antenna Height (m)	Table Angle (Degree)	Raw Value (dBuV)	Correction Factor (dB/m)
1	53.33	33.59 QP	83.45	-51.14	1.25 H	217	19.86	13.72
2	179.68	26.78 QP	83.45	-56.67	1.00 H	229	14.25	12.53
3	239.94	23.90 QP	83.45	-59.55	1.00 H	67	10.72	13.17
4	366.29	25.19 QP	83.45	-58.26	2.00 H	157	8.35	16.84
5	432.38	26.24 QP	83.45	-57.21	1.50 H	103	7.50	18.74
6	445.99	30.43 QP	83.45	-53.02	1.75 H	172	11.26	19.17
7	473.21	33.01 QP	83.45	-50.44	1.00 H	313	13.38	19.63
8	480.98	31.68 QP	83.45	-51.77	1.00 H	322	11.94	19.74
9	539.30	29.47 QP	83.45	-53.98	1.00 H	124	8.58	20.88
10	607.33	30.77 QP	83.45	-52.68	1.50 H	355	8.07	22.70
11	667.60	28.14 QP	83.45	-55.31	1.50 H	10	4.63	23.51
12	720.08	29.84 QP	83.45	-53.61	1.25 H	1	5.31	24.53

REMARKS:

1. Emission level(dBuV/m)=Raw Value(dBuV) + Correction Factor(dB)
2. Correction Factor(dB/m) = Antenna Factor (dB/m) + Cable Factor (dB)
3. The other emission levels were very low against the limit.
4. Margin value = Emission level – Limit value.
5. This is valid for all 3 channels

EUT	Smartphone	MODEL	P30 (57P30), BenQ P30
MODE	TX connected Ch.512 E2 plane	FREQUENCY RANGE	Below 1000 MHz
INPUT POWER (SYSTEM)	120Vac, 60 Hz	DETECTOR FUNCTION	Quasi-Peak
ENVIRONMENTAL CONDITIONS	26 deg. C, 78 % RH, 991 hPa	TESTED BY: Steven Lu	

ANTENNA POLARITY & TEST DISTANCE: VERTICAL AT 3 M								
No.	Freq. (MHz)	Emission Level (dBuV/m)	Limit (dBuV/m)	Margin (dB)	Antenna Height (m)	Table Angle (Degree)	Raw Value (dBuV)	Correction Factor (dB/m)
1	53.33	33.09 QP	83.45	-51.14	1.00 V	226	19.37	13.72
2	86.37	25.51 QP	83.45	-57.94	2.00 V	64	16.12	9.39
3	179.68	24.64 QP	83.45	-58.81	1.00 V	211	12.11	12.53
4	239.94	21.99 QP	83.45	-61.46	1.00 V	112	8.82	13.17
5	366.29	26.29 QP	83.45	-57.16	1.00 V	328	9.44	16.84
6	445.99	31.53 QP	83.45	-51.92	1.00 V	319	12.35	19.17
7	453.77	31.97 QP	83.45	-51.48	1.00 V	328	12.62	19.35
8	473.21	33.94 QP	83.45	-49.51	1.00 V	352	14.31	19.63
9	539.30	32.93 QP	83.45	-50.52	2.00 V	340	12.05	20.88
10	607.33	31.15 QP	83.45	-52.3	2.00 V	7	8.45	22.70
11	667.60	29.17 QP	83.45	-54.28	1.00 V	7	5.66	23.51
12	727.86	26.92 QP	83.45	-56.53	1.00 V	169	2.18	24.74

ANTENNA POLARITY & TEST DISTANCE: HORIZONTAL AT 3 M								
No.	Freq. (MHz)	Emission Level (dBuV/m)	Limit (dBuV/m)	Margin (dB)	Antenna Height (m)	Table Angle (Degree)	Raw Value (dBuV)	Correction Factor (dB/m)
1	55.27	33.05 QP	83.45	-51.14	1.00 H	169	19.50	13.55
2	86.37	20.80 QP	83.45	-62.65	1.00 H	4	11.41	9.39
3	179.68	24.56 QP	83.45	-58.89	1.00 H	235	12.04	12.53
4	366.29	25.66 QP	83.45	-57.79	1.00 H	328	8.82	16.84
5	426.55	27.65 QP	83.45	-55.8	1.00 H	355	9.10	18.55
6	445.99	30.95 QP	83.45	-52.5	1.00 H	334	11.78	19.17
7	453.77	31.46 QP	83.45	-51.99	1.00 H	331	12.11	19.35
8	473.21	34.14 QP	83.45	-49.31	1.00 H	334	14.52	19.63
9	479.04	32.87 QP	83.45	-50.58	1.00 H	4	13.16	19.71
10	539.30	33.40 QP	83.45	-50.05	2.00 H	331	12.51	20.88
11	599.56	32.19 QP	83.45	-51.26	2.00 H	1	9.60	22.59
12	653.99	28.15 QP	83.45	-55.3	1.00 H	16	4.85	23.31
13	720.08	27.60 QP	83.45	-55.85	1.00 H	352	3.07	24.53

REMARKS:

1. Emission level(dBuV/m)=Raw Value(dBuV) + Correction Factor(dB)
2. Correction Factor(dB/m) = Antenna Factor (dB/m) + Cable Factor (dB)
3. The other emission levels were very low against the limit.
4. Margin value = Emission level – Limit value.
5. This is valid for all 3 channels

EUT	Smartphone	MODEL	P30 (57P30), BenQ P30
MODE	TX connected Channel 512 H plane	FREQUENCY RANGE	Above 1000 MHz
INPUT POWER (SYSTEM)	120Vac, 60 Hz	DETECTOR FUNCTION	Peak
ENVIRONMENTAL CONDITIONS	26 deg. C, 78 % RH, 991 hPa	TESTED BY: Steven Lu	

ANTENNA POLARITY & TEST DISTANCE: VERTICAL AT 3 M

No.	Freq. (MHz)	Emission Level (dBuV/m)	Limit (dBuV/m)	Margin (dB)	Antenna Height (m)	Table Angle (Degree)	Raw Value (dBuV)	Correction Factor (dB/m)
1	3700.20	66.06 PK	83.45	-17.39	1.00 V	25	30.12	35.94
2	5550.35	63.42 PK	83.45	-20.03	1.22 V	301	24.18	39.25
3	7400.60	68.21 PK	83.45	-15.24	1.36 V	152	25.75	42.46
4	9250.97	72.32 PK	83.45	-11.13	1.12 V	253	27.61	44.71
5	11101.17	68.98 PK	83.45	-14.47	1.15 V	234	23.44	45.54
6	12951.40	78.98 PK	83.45	-4.47	1.00 V	195	31.68	47.31
7	14801.60	67.70 PK	83.45	-15.75	1.40 V	189	17.95	49.75

ANTENNA POLARITY & TEST DISTANCE: HORIZONTAL AT 3 M

No.	Freq. (MHz)	Emission Level (dBuV/m)	Limit (dBuV/m)	Margin (dB)	Antenna Height (m)	Table Angle (Degree)	Raw Value (dBuV)	Correction Factor (dB/m)
1	3700.37	62.06 PK	83.45	-21.39	1.12 H	52	26.12	35.94
2	5550.57	62.09 PK	83.45	-21.36	1.04 H	192	22.85	39.25
3	7400.47	64.05 PK	83.45	-19.40	1.13 H	20	21.59	42.46
4	9250.93	75.99 PK	83.45	-7.46	1.19 H	163	31.28	44.71
5	11101.13	77.61 PK	83.45	-5.84	1.26 H	185	32.07	45.54
6	12950.85	76.31 PK	83.45	-7.14	1.12 H	177	29.00	47.31
7	14801.20	69.87 PK	83.45	-13.58	1.35 H	175	20.11	49.76
8	16652.07	61.13 PK	83.45	-22.32	1.14 H	230	12.57	48.56

REMARKS:

1. Emission level(dBuV/m)=Raw Value(dBuV) + Correction Factor(dB)
2. Correction Factor(dB/m) = Antenna Factor (dB/m) + Cable Factor (dB)
3. The other emission levels were very low against the limit.
4. Margin value = Emission level – Limit value.

EUT	Smartphone	MODEL	P30 (57P30), BenQ P30
MODE	TX connected Channel 512 E1 plane	FREQUENCY RANGE	Above 1000 MHz
INPUT POWER (SYSTEM)	120Vac, 60 Hz	DETECTOR FUNCTION	Peak
ENVIRONMENTAL CONDITIONS	24deg. C, 70 % RH, 991 hPa	TESTED BY: Steven Lu	

ANTENNA POLARITY & TEST DISTANCE: VERTICAL AT 3 M								
No.	Freq. (MHz)	Emission Level (dBuV/m)	Limit (dBuV/m)	Margin (dB)	Antenna Height (m)	Table Angle (Degree)	Raw Value (dBuV)	Correction Factor (dB/m)
1	3700.00	63.16 PK	83.45	-20.29	1.14 V	217	24.94	38.22
2	5550.00	60.69 PK	83.45	-22.76	1.20 V	236	18.55	42.13
3	7401.00	72.23 PK	83.45	-11.19	1.08 V	230	27.04	45.19
4	9250.00	55.96 PK	83.45	-27.49	1.22 V	104	8.17	47.79
5	11101.00	79.75 PK	83.45	-3.70	1.01 V	3	30.32	49.43
6	12951.00	68.08 PK	83.45	-15.37	1.11 V	289	15.95	52.13

ANTENNA POLARITY & TEST DISTANCE: HORIZONTAL AT 3 M								
No.	Freq. (MHz)	Emission Level (dBuV/m)	Limit (dBuV/m)	Margin (dB)	Antenna Height (m)	Table Angle (Degree)	Raw Value (dBuV)	Correction Factor (dB/m)
1	3700.00	60.55 PK	83.45	-22.90	1.17 H	220	22.34	38.22
2	5550.00	60.99 PK	83.45	-22.46	1.37 H	236	18.85	42.13
3	7401.00	70.23 PK	83.45	-13.22	1.78 H	5	25.04	45.19
4	9251.00	73.16 PK	83.45	-10.29	1.04 H	268	25.37	47.79
5	11101.00	82.05 PK	83.45	-1.40	1.28 H	36	32.62	49.43

REMARKS:

1. Emission level(dBuV/m)=Raw Value(dBuV) + Correction Factor(dB)
2. Correction Factor(dB/m) = Antenna Factor (dB/m) + Cable Factor (dB)
3. The other emission levels were very low against the limit.
4. Margin value = Emission level – Limit value.

EUT	Smartphone	MODEL	P30 (57P30), BenQ P30
MODE	TX connected Channel 512 E2 plane	FREQUENCY RANGE	Above 1000 MHz
INPUT POWER (SYSTEM)	120Vac, 60 Hz	DETECTOR FUNCTION	Peak
ENVIRONMENTAL CONDITIONS	26 deg. C, 78 % RH, 991 hPa	TESTED BY: Steven Lu	

ANTENNA POLARITY & TEST DISTANCE: VERTICAL AT 3 M								
No.	Freq. (MHz)	Emission Level (dBuV/m)	Limit (dBuV/m)	Margin (dB)	Antenna Height (m)	Table Angle (Degree)	Raw Value (dBuV)	Correction Factor (dB/m)
1	3700.70	59.39 PK	83.45	-24.06	1.17 V	112	23.45	35.94
2	5550.90	55.25 PK	83.45	-28.20	1.41 V	316	16.01	39.25
3	7401.10	63.59 PK	83.45	-19.86	1.34 V	82	21.12	42.46
4	9250.67	69.65 PK	83.45	-13.80	1.23 V	159	24.94	44.71
5	11101.45	73.28 PK	83.45	-10.17	1.43 V	243	27.74	45.54
6	12951.65	69.98 PK	83.45	-13.47	1.48 V	214	22.68	47.31
7	14801.85	64.20 PK	83.45	-19.25	1.53 V	142	14.45	49.75

ANTENNA POLARITY & TEST DISTANCE: HORIZONTAL AT 3 M								
No.	Freq. (MHz)	Emission Level (dBuV/m)	Limit (dBuV/m)	Margin (dB)	Antenna Height (m)	Table Angle (Degree)	Raw Value (dBuV)	Correction Factor (dB/m)
1	3700.70	59.06 PK	83.45	-24.39	1.00 H	115	23.12	35.94
2	5550.90	54.42 PK	83.45	-29.03	1.54 H	252	15.18	39.25
3	7401.10	62.72 PK	83.45	-20.73	1.38 H	25	20.25	42.46
4	9251.30	58.65 PK	83.45	-24.80	1.31 H	346	13.94	44.70
5	11101.50	70.28 PK	83.45	-13.17	1.23 H	137	24.74	45.54
6	12951.70	70.31 PK	83.45	-13.14	1.50 H	236	23.01	47.31
7	14801.90	65.70 PK	83.45	-17.75	1.48 H	356	15.95	49.75

REMARKS:

1. Emission level(dBuV/m)=Raw Value(dBuV) + Correction Factor(dB)
2. Correction Factor(dB/m) = Antenna Factor (dB/m) + Cable Factor (dB)
3. The other emission levels were very low against the limit.
4. Margin value = Emission level – Limit value.

EUT	Smartphone	MODEL	P30 (57P30), BenQ P30
MODE	TX connected Channel 661 H plane	FREQUENCY RANGE	Above 1000 MHz
INPUT POWER (SYSTEM)	120Vac, 60 Hz	DETECTOR FUNCTION	Peak
ENVIRONMENTAL CONDITIONS	26 deg. C, 78 % RH, 991 hPa	TESTED BY: Steven Lu	

ANTENNA POLARITY & TEST DISTANCE: VERTICAL AT 3 M

No.	Freq. (MHz)	Emission Level (dBuV/m)	Limit (dBuV/m)	Margin (dB)	Antenna Height (m)	Table Angle (Degree)	Raw Value (dBuV)	Correction Factor (dB/m)
1	3759.92	66.28 PK	83.27	-16.99	1.40 V	52	30.16	36.13
2	5640.00	61.92 PK	83.27	-21.35	1.18 V	318	22.50	39.41
3	7520.00	64.49 PK	83.27	-18.78	1.06 V	337	21.89	42.60
4	9400.00	74.96 PK	83.27	-8.31	1.18 V	159	30.59	44.37
5	11279.63	75.87 PK	83.27	-7.40	1.10 V	217	30.01	45.86
6	13160.95	79.07 PK	83.27	-4.20	1.12 V	210	31.36	47.71
7	15039.85	68.79 PK	83.27	-14.48	1.14 V	238	20.02	48.77
8	16920.95	65.38 PK	83.27	-17.89	1.30 V	248	16.14	49.24

ANTENNA POLARITY & TEST DISTANCE: HORIZONTAL AT 3 M

No.	Freq. (MHz)	Emission Level (dBuV/m)	Limit (dBuV/m)	Margin (dB)	Antenna Height (m)	Table Angle (Degree)	Raw Value (dBuV)	Correction Factor (dB/m)
1	3760.17	66.62 PK	83.27	-16.65	1.26 H	147	30.49	36.13
2	5640.07	58.76 PK	83.27	-24.51	1.11 H	100	19.34	39.41
3	7520.17	60.82 PK	83.27	-22.45	1.10 H	283	18.22	42.60
4	9400.17	74.79 PK	83.27	-8.48	1.18 H	168	30.42	44.37
5	11280.07	75.90 PK	83.27	-7.37	1.27 H	198	30.04	45.86
6	13160.07	76.70 PK	83.27	-6.57	1.08 H	163	28.99	47.71
7	15040.70	69.12 PK	83.27	-14.15	1.23 H	80	20.35	48.77
8	16920.95	65.08 PK	83.27	-18.19	1.40 H	253	15.84	49.24

REMARKS:

1. Emission level(dBuV/m)=Raw Value(dBuV) + Correction Factor(dB)
2. Correction Factor(dB/m) = Antenna Factor (dB/m) + Cable Factor (dB)
3. The other emission levels were very low against the limit.
4. Margin value = Emission level – Limit value.

EUT	Smartphone	MODEL	P30 (57P30), BenQ P30
MODE	TX connected Channel 661 E1 plane	FREQUENCY RANGE	Above 1000 MHz
INPUT POWER (SYSTEM)	120Vac, 60 Hz	DETECTOR FUNCTION	Peak
ENVIRONMENTAL CONDITIONS	24 deg. C, 70 % RH, 991 hPa	TESTED BY: Steven Lu	

ANTENNA POLARITY & TEST DISTANCE: VERTICAL AT 3 M								
No.	Freq. (MHz)	Emission Level (dBuV/m)	Limit (dBuV/m)	Margin (dB)	Antenna Height (m)	Table Angle (Degree)	Raw Value (dBuV)	Correction Factor (dB/m)
1	3760.00	66.67 PK	83.27	-16.60	1.29 V	360	27.77	38.89
2	5640.00	62.78 PK	83.27	-20.49	1.11 V	12	20.46	42.32
3	7520.00	65.61 PK	83.27	-17.66	1.14 V	45	20.10	45.50
4	9400.00	71.77 PK	83.27	-11.50	1.10 V	247	24.80	46.97
5	11280.00	77.57 PK	83.27	-5.70	1.24 V	44	27.09	50.47
6	13160.00	79.59 PK	83.27	-3.68	1.20 V	337	26.34	53.25

ANTENNA POLARITY & TEST DISTANCE: HORIZONTAL AT 3 M								
No.	Freq. (MHz)	Emission Level (dBuV/m)	Limit (dBuV/m)	Margin (dB)	Antenna Height (m)	Table Angle (Degree)	Raw Value (dBuV)	Correction Factor (dB/m)
1	3760.00	65.97 PK	83.27	-17.30	1.05 H	45	27.07	38.89
2	5640.00	65.38 PK	83.27	-17.89	1.20 H	12	23.06	42.32
3	7520.00	65.11 PK	83.27	-18.16	1.20 H	22	19.60	45.50
4	9400.00	74.27 PK	83.27	-9.00	1.11 H	129	27.30	46.97
5	11280.00	78.57 PK	83.27	-4.70	1.43 H	2	28.09	50.47
6	13160.00	82.69 PK	83.27	-0.58	1.10 H	238	29.44	53.25
7	15040.00	83.13 PK	83.27	-0.14	1.64 H	4	28.59	54.54

REMARKS:

1. Emission level(dBuV/m)=Raw Value(dBuV) + Correction Factor(dB)
2. Correction Factor(dB/m) = Antenna Factor (dB/m) + Cable Factor (dB)
3. The other emission levels were very low against the limit.
4. Margin value = Emission level – Limit value.

EUT	Smartphone	MODEL	P30 (57P30), BenQ P30
MODE	TX connected Channel 661 E2 plane	FREQUENCY RANGE	Above 1000 MHz
INPUT POWER (SYSTEM)	120Vac, 60 Hz	DETECTOR FUNCTION	Peak
ENVIRONMENTAL CONDITIONS	26 deg. C, 78 % RH, 991 hPa	TESTED BY: Steven Lu	

ANTENNA POLARITY & TEST DISTANCE: VERTICAL AT 3 M								
No.	Freq. (MHz)	Emission Level (dBuV/m)	Limit (dBuV/m)	Margin (dB)	Antenna Height (m)	Table Angle (Degree)	Raw Value (dBuV)	Correction Factor (dB/m)
1	3760.12	60.96 PK	83.27	-22.31	1.09 V	111	24.83	36.13
2	5640.02	59.26 PK	83.27	-24.01	1.49 V	55	19.84	39.41
3	7520.00	57.82 PK	83.27	-25.45	1.05 V	334	15.22	42.60
4	9399.68	65.96 PK	83.27	-17.31	1.32 V	57	21.59	44.37
5	11280.00	64.71 PK	83.27	-18.56	1.22 V	336	18.85	45.86
6	13160.00	69.87 PK	83.27	-13.40	1.58 V	213	22.16	47.71
7	15040.00	65.12 PK	83.27	-18.15	1.28 V	73	16.35	48.77

ANTENNA POLARITY & TEST DISTANCE: HORIZONTAL AT 3 M								
No.	Freq. (MHz)	Emission Level (dBuV/m)	Limit (dBuV/m)	Margin (dB)	Antenna Height (m)	Table Angle (Degree)	Raw Value (dBuV)	Correction Factor (dB/m)
1	3760.00	63.46 PK	83.27	-19.81	1.21 H	24	27.33	36.13
2	5640.00	54.59 PK	83.27	-28.68	1.14 H	53	15.17	39.41
3	7520.00	59.82 PK	83.27	-23.45	1.43 H	360	17.22	42.60
4	9400.00	64.13 PK	83.27	-19.14	1.50 H	7	19.76	44.37
5	11280.00	66.54 PK	83.27	-16.73	1.11 H	333	20.68	45.86
6	13160.00	68.07 PK	83.27	-15.20	1.26 H	232	20.36	47.71

REMARKS:

1. Emission level(dBuV/m)=Raw Value(dBuV) + Correction Factor(dB)
2. Correction Factor(dB/m) = Antenna Factor (dB/m) + Cable Factor (dB)
3. The other emission levels were very low against the limit.
4. Margin value = Emission level – Limit value.

EUT	Smartphone	MODEL	P30 (57P30), BenQ P30
MODE	TX connected Channel 810 H plane	FREQUENCY RANGE	Above 1000 MHz
INPUT POWER (SYSTEM)	120Vac, 60 Hz	DETECTOR FUNCTION	Peak
ENVIRONMENTAL CONDITIONS	26 deg. C, 78 % RH, 991 hPa	TESTED BY: Steven Lu	

ANTENNA POLARITY & TEST DISTANCE: VERTICAL AT 3 M								
No.	Freq. (MHz)	Emission Level (dBuV/m)	Limit (dBuV/m)	Margin (dB)	Antenna Height (m)	Table Angle (Degree)	Raw Value (dBuV)	Correction Factor (dB/m)
1	3819.74	69.89 PK	84.81	-14.92	1.20 V	56	33.52	36.38
2	5729.61	57.62 PK	84.81	-27.19	1.14 V	359	18.00	39.62
3	7639.19	51.92 PK	84.81	-32.89	1.17 V	229	9.18	42.74
4	9548.68	74.87 PK	84.81	-9.94	1.14 V	150	30.57	44.30
5	11458.42	65.91 PK	84.81	-18.90	1.07 V	132	19.95	45.96
6	13368.86	76.17 PK	84.81	-8.64	1.04 V	237	27.97	48.20
7	15277.91	66.67 PK	84.81	-18.14	1.00 V	100	18.99	47.68
8	17187.54	66.97 PK	84.81	-17.84	1.20 V	88	15.61	51.36

ANTENNA POLARITY & TEST DISTANCE: HORIZONTAL AT 3 M								
No.	Freq. (MHz)	Emission Level (dBuV/m)	Limit (dBuV/m)	Margin (dB)	Antenna Height (m)	Table Angle (Degree)	Raw Value (dBuV)	Correction Factor (dB/m)
1	3819.43	69.39 PK	84.81	-15.42	1.16 H	62	33.02	36.38
2	5729.42	57.79 PK	84.81	-27.02	1.18 H	348	18.17	39.62
3	7638.88	63.92 PK	84.81	-20.89	1.56 H	226	21.18	42.74
4	9548.66	73.70 PK	84.81	-11.11	1.26 H	155	29.40	44.30
5	11458.98	64.91 PK	84.81	-19.90	1.09 H	110	18.95	45.96
6	13368.59	72.80 PK	84.81	-12.01	1.17 H	222	24.60	48.20
7	15278.14	64.50 PK	84.81	-20.31	1.05 H	192	16.82	47.68

REMARKS:

1. Emission level(dBuV/m)=Raw Value(dBuV) + Correction Factor(dB)
2. Correction Factor(dB/m) = Antenna Factor (dB/m) + Cable Factor (dB)
3. The other emission levels were very low against the limit.
4. Margin value = Emission level – Limit value.

EUT	Smartphone	MODEL	P30 (57P30), BenQ P30
MODE	TX connected Channel 810 E1 plane	FREQUENCY RANGE	Above 1000 MHz
INPUT POWER (SYSTEM)	120Vac, 60 Hz	DETECTOR FUNCTION	Peak
ENVIRONMENTAL CONDITIONS	24 deg. C, 70 % RH, 991 hPa	TESTED BY: Steven Lu	

ANTENNA POLARITY & TEST DISTANCE: VERTICAL AT 3 M

No.	Freq. (MHz)	Emission Level (dBuV/m)	Limit (dBuV/m)	Margin (dB)	Antenna Height (m)	Table Angle (Degree)	Raw Value (dBuV)	Correction Factor (dB/m)
1	3819.96	64.74 PK	84.81	-20.07	1.22 V	357	25.41	39.33
2	5729.49	62.52 PK	84.81	-22.29	1.16 V	224	19.97	42.55
3	7639.23	74.39 PK	84.81	-10.42	1.18 V	54	28.77	45.62
4	9541.95	72.53 PK	84.81	-12.28	1.44 V	12	25.32	47.21
5	11458.98	73.62 PK	84.81	-11.19	1.34 V	65	22.36	51.26
6	15278.64	79.22 PK	84.81	-5.59	1.23 V	118	25.42	53.80

ANTENNA POLARITY & TEST DISTANCE: HORIZONTAL AT 3 M

No.	Freq. (MHz)	Emission Level (dBuV/m)	Limit (dBuV/m)	Margin (dB)	Antenna Height (m)	Table Angle (Degree)	Raw Value (dBuV)	Correction Factor (dB/m)
1	3819.96	67.74 PK	84.81	-17.07	1.45 H	11	28.41	39.33
2	5729.49	58.02 PK	84.81	-26.79	1.25 H	54	15.47	42.55
3	7639.32	62.89 PK	84.81	-21.92	1.64 H	156	17.27	45.62
4	9549.15	71.92 PK	84.81	-12.89	1.20 H	12	24.72	47.20
5	11458.98	72.02 PK	84.81	-12.79	1.12 H	21	20.76	51.26
6	15278.64	81.02 PK	84.81	-3.79	1.12 H	21	27.22	53.80

REMARKS:

1. Emission level(dBuV/m)=Raw Value(dBuV) + Correction Factor(dB)
2. Correction Factor(dB/m) = Antenna Factor (dB/m) + Cable Factor (dB)
3. The other emission levels were very low against the limit.
4. Margin value = Emission level – Limit value.

EUT	Smartphone	MODEL	P30 (57P30), BenQ P30
MODE	TX connected Channel 810 E2 plane	FREQUENCY RANGE	Above 1000 MHz
INPUT POWER (SYSTEM)	120Vac, 60 Hz	DETECTOR FUNCTION	Peak
ENVIRONMENTAL CONDITIONS	26 deg. C, 78 % RH, 991 hPa	TESTED BY: Steven Lu	

ANTENNA POLARITY & TEST DISTANCE: VERTICAL AT 3 M								
No.	Freq. (MHz)	Emission Level (dBuV/m)	Limit (dBuV/m)	Margin (dB)	Antenna Height (m)	Table Angle (Degree)	Raw Value (dBuV)	Correction Factor (dB/m)
1	3819.96	59.07 PK	84.81	-25.74	1.38 V	332	22.69	36.38
2	5729.49	57.79 PK	84.81	-27.02	1.21 V	312	18.17	39.62
3	7639.23	61.55 PK	84.81	-23.26	1.53 V	133	18.81	42.74
4	9541.95	67.83 PK	84.81	-16.98	1.32 V	177	23.53	44.30
5	11458.98	60.91 PK	84.81	-23.90	1.22 V	222	14.95	45.96
6	13368.84	67.13 PK	84.81	-17.68	1.60 V	152	18.93	48.20
7	15278.64	63.63 PK	84.81	-21.18	1.23 V	189	15.95	47.68

ANTENNA POLARITY & TEST DISTANCE: HORIZONTAL AT 3 M								
No.	Freq. (MHz)	Emission Level (dBuV/m)	Limit (dBuV/m)	Margin (dB)	Antenna Height (m)	Table Angle (Degree)	Raw Value (dBuV)	Correction Factor (dB/m)
1	3819.96	62.40 PK	84.81	-22.41	1.23 H	138	26.02	36.38
2	5729.49	54.12 PK	84.81	-30.69	1.00 H	304	14.50	39.62
3	7639.32	56.59 PK	84.81	-28.22	1.40 H	140	13.85	42.74
4	9549.15	62.07 PK	84.81	-22.74	1.30 H	6	17.77	44.30
5	11458.98	60.91 PK	84.81	-23.90	1.32 H	293	14.95	45.96
6	13368.81	68.00 PK	84.81	-16.81	1.43 H	233	19.80	48.20
7	15278.64	60.83 PK	84.81	-23.98	1.38 H	88	13.15	47.68

REMARKS:

1. Emission level(dBuV/m)=Raw Value(dBuV) + Correction Factor(dB)
2. Correction Factor(dB/m) = Antenna Factor (dB/m) + Cable Factor (dB)
3. The other emission levels were very low against the limit.
4. Margin value = Emission level – Limit value.

5 PHOTOGRAPHS OF THE TEST CONFIGURATION

RADIATED EMISSION TEST





6 INFORMATION ON THE TESTING LABORATORIES

We, ADT Corp., were founded in 1988 to provide our best service in EMC and Safety consultation. Our laboratories are accredited and approved by the following approval agencies according to ISO/IEC 17025, Guide 25 or EN 45001:

USA	FCC, NVLAP
Germany	TUV Rheinland
Japan	VCCI
New Zealand	MoC
Norway	NEMKO
R.O.C.	BSMI, DGT, CNLA

Copies of accreditation certificates of our laboratories obtained from approval agencies can be downloaded from our web site:

www.adt.com.tw/index.5/phtml.

If you have any comments, please feel free to contact us at the following:

Lin Kou EMC Lab:

Tel: 886-2-26052180

Fax: 886-2-26052943

Hsin Chu EMC Lab:

Tel: 886-35-935343

Fax: 886-35-935342

Lin Kou Safety Lab:

Tel: 886-2-26093195

Fax: 886-2-26093184

Lin Kou RF&Telecom Lab

Tel: 886-3-3270910

Fax: 886-3-3270892

Email: service@mail.adt.com.tw

Web Site: www.adt.com.tw

The address and road map of all our labs can be found in our web site also.