



**FCC CFR47 CERTIFICATION  
CLASS II PERMISSIVE CHANGE**

**PART 24E**

**TEST REPORT**

***FOR***

**TRIM TRAC**

**MODEL: 51200-10**

**FCC ID: JUPTRIMTRAC1**

**REPORT NUMBER: 04U3020-1**

**ISSUE DATE: OCTOBER 21, 2004**

*Prepared for*  
**TRIMBLE NAVIGATION (MG)  
645 NORTH MARY AVE.  
SUNNYVAL, CA 94088-3642, USA**

*Prepared by*  
**COMPLIANCE CERTIFICATION SERVICES  
561F MONTEREY ROAD, ROUTE 2  
MORGAN HILL, CA 95037, USA  
TEL: (408) 463-0885  
FAX: (408) 463-0888**

**NVLAB<sup>®</sup>**

**LAB CODE:200065-0**

## TABLE OF CONTENT

<b>1. TEST RESULT CERTIFICATION.....</b>	<b>3</b>
<b>2. EUT DESCRIPTION _ CLASS II PERMISSIVE CHANGE .....</b>	<b>4</b>
<b>3. TEST METHODOLOGY .....</b>	<b>4</b>
<b>4. TEST FACILITY.....</b>	<b>4</b>
<b>5. ACCREDITATION AND LISTING.....</b>	<b>4</b>
<b>6. MEASURING INSTRUMENT CALIBRATION .....</b>	<b>5</b>
<b>7. TEST SETUP, PROCEDURE AND RESULT.....</b>	<b>6</b>
7.1. SECTION 2.1046: RF POWER OUTPUT .....	6
7.2. SECTION 2.1047: MODULATION CHARACTERISTICS .....	14
7.3. SECTION 2.1049: OCCUPIED BANDWIDTH .....	14
7.4. SECTION 2.1051: SPURIOUS EMISSION AT ANTENNA TERMINAL .....	18
7.5. SECTION 2.1053: FIELD STRENGTH OF SPURIOUS RADIATION .....	24
7.6. SECTION 2.1055: FREQUENCY STABILITY .....	31

# 1. TEST RESULT CERTIFICATION

**COMPANY NAME:** TRIMBLE NAVIGATION LIMITED  
645 NORTH MARY AVE.  
SUNNYVALE, CA 94088

**EUT DESCRIPTION:** TRIM TRAC

**MODEL NUMBER:** 51200-10

**DATE TESTED:** OCTOBER 19 TO 20, 2004

TYPE OF EQUIPMENT	INTENTIONAL RADIATOR, LICENSED TX MODULE IN MOBILE APPLICATION
MEASUREMENT PROCEDURE	ANSI C63.4 / 2001, TIA/EIA 603
PROCEDURE	CERTIFICATION
FCC RULE	CFR 47 PART 24 Subpart E

Compliance Certification Services, Inc. tested the above equipment for compliance with the requirement set forth in CFR 47, PART 24 Subpart E-Broadband PCS. The equipment in the configuration described in this report, shows the measured emission levels emanating from the equipment do not exceed the specified limit.

**Note:** This document reports conditions under which testing was conducted and results of tests performed. This document may not be altered or revised in any way unless done so by Compliance Certification Services and all revisions are duly noted in the revisions section. Any alteration of this document not carried out by Compliance Certification Services will constitute fraud and shall nullify the document.

Tested By:



VIEN TRAN  
EMC TECHNICIAN  
COMPLIANCE CERTIFICATION SERVICES

Released For CCS By:



THU CHAN  
EMC SUPERVISOR  
COMPLIANCE CERTIFICATION SERVICES

## **2. EUT DESCRIPTION \_ CLASS II PERMISSIVE CHANGE**

The EUT is a Tri-band GSM cellular transceiver with GPS receiver built-in. The device is a stand-alone unit design to be placed in a high-value asset such as a vehicle or cargo-container.

The device has built in Tri-Band GSM900, DCS1800, and PCS1900 cellular antenna embedded in the only PCS used in the product.

The EUT of GSM1900 has an output power of 31.6dBm / 1.445W (EIRP) which is designed for the bands transmitting of frequency range 1850.2MHz to 1909.9MHz.

The major changes filed under this application are:

Change #1: New power module for vehicles.

#2: Different plastic enclosure.

## **3. TEST METHODOLOGY**

Both conducted and radiated testing were performed according to the procedures documented on chapter 13 of ANSI C63.4 and FCC CFR 47 2.1046, 2.1047, 2.1049, 2.1051, 2.1053, 2.1055 and 2.1057.

## **4. TEST FACILITY**

The open area test sites and conducted measurement facilities used to collect the radiated data are located at 561F Monterey Road, Morgan Hill, California, USA. The sites are constructed in conformance with the requirements of ANSI C63.7, ANSI C63.4 and CISPR Publication 22.

## **5. ACCREDITATION AND LISTING**

The test facilities used to perform radiated and conducted emissions tests are accredited by National Voluntary Laboratory Accreditation Program for the specific scope of accreditation under Lab Code: 200065-0 to perform Electromagnetic Interference tests according to FCC PART 15 AND CISPR 22 requirements. No part of this report may be used to claim or imply product endorsement by NVLAP or any agency of the US Government. In addition, the test facilities are listed with Federal Communications Commission (reference no: 31040/SIT (1300B3) and 31040/SIT (1300F2))

## 6. MEASURING INSTRUMENT CALIBRATION

The measuring equipment, which was utilized in performing the tests documented herein, has been calibrated in accordance with the manufacturer's recommendations for utilizing calibration equipment, which is traceable to recognized national standards.

## 7. TEST SETUP, PROCEDURE AND RESULT

### 7.1. SECTION 2.1046: RF POWER OUTPUT

#### INSTRUMENTS LIST

EQUIPMENT	MANUFACTURE	MODEL NO.	SERIAL NO.	CAL. DUE DATE
PSA Analyzer	Agilent	E4446A	MY43360112	1/13/05
DC Power Supply	Kenwood	PA36-3A	7060074	N/A
30MHz---- 2Ghz	Sunol Sciences	JB1 Antenna	A121003	12/22/2004
Tune Dipole	ETS	DB-4	1629	5/14/05
Tx Horn Antenna	EMCO	3115	6739	2/4/2005
Rx Horn Antenna	EMCO	3115	6717	2/4/2005
Amplifier	MITEQ	NSP2600-SP	924342	4/25/2005
HPF	MICROLAB	FH-2400H	N/A	N/A

#### MEASUREMENT PROCEDURE

- 1). On a test site, the EUT shall be placed on a turntable, and in the position closest to the normal use as declared by the user.
- 2). The test antenna shall be oriented initially for vertical polarization located 3m from the EUT to correspond to the frequency of the transmitter.
- 3). The output of the test antenna shall be connected to the measuring receiver and either a peak or quasi-peak detector was used for the measurement as indicated on the report. The detector selection is based on how close the emission level was approaching the limit.
- 4). The transmitter shall be placed 0.80 meter above the ground plane, the X, Y, and Z positions shall be tested and the worst case reported. The transmitter shall be switched on with typical modulation and the measurement receiver shall be tuned to the frequency of the transmitter under test.

- 5). The test antenna shall be raised and lowered through the specified range of height until the measuring receiver detects a maximum signal level.
- 6). The transmitter shall than be rotated through 360° in the horizontal plane, until the maximum signal level is detected by the measuring receiver.
- 7). The test antenna shall be raised and lowered again through the specified range of height until a maximum signal level is detected by the measuring receiver.
- 8). The maximum signal level detected by the measuring receiver shall be noted.
- 9). The transmitter shall be replaced by a tuned dipole / horn (substitution antenna).
- 10). The substitution antenna shall be oriented for vertical polarization and the length of the substitution antenna shall be adjusted to correspond to the frequency of the transmitter.
- 11). The substitution antenna shall be connected to a calibrated signal generator.
- 12). If necessary, the input attenuator setting of the measuring receiver shall be adjusted in order to increase the sensitivity of the measuring receiver.
- 13). The test antenna shall be raised and lowered through the specified range of the height to ensure that the maximum signal is received.
- 14). The input signal to the substitution antenna shall be adjusted to the level that produces a level detected by the measuring receiver, that is equal to the level noted while the transmitter radiated power was measured, corrected for the change of input attenuation setting of the measuring receiver.
- 15). The input level to the substitution antenna shall be recorded as power level in dBm, corrected for any change of input attenuator setting of the measuring receiver.
- 16). The measurement shall be repeated with the test antenna and the substitution antenna oriented for horizontal polarization.
- 17). The measure of the effective radiated power is the larger of the two levels recorded, at the input to the substitution antenna, corrected for the gain of the substitution antenna if necessary.

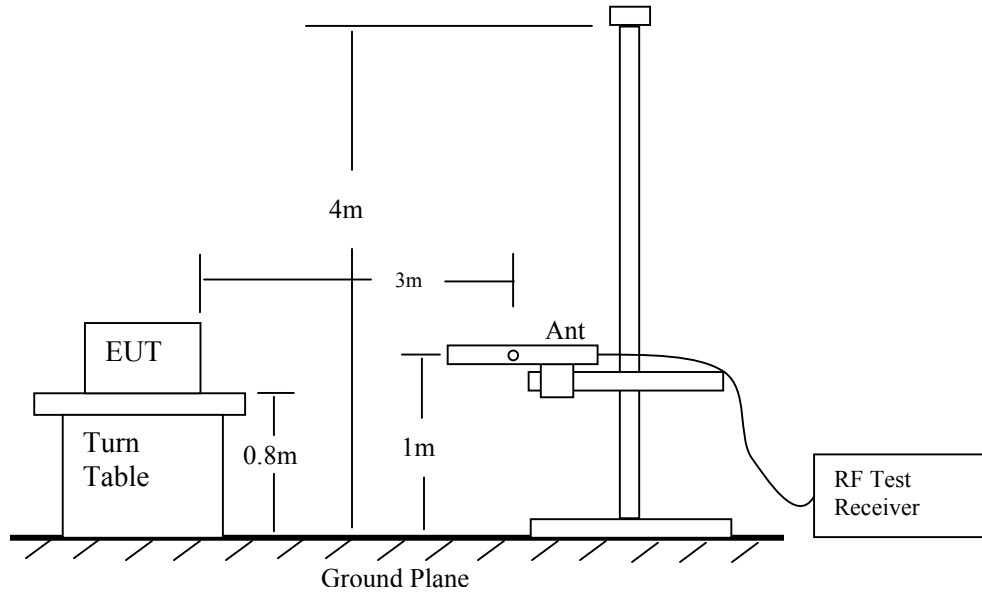

Radiated Emission Measurement 30 to 1000 MHz

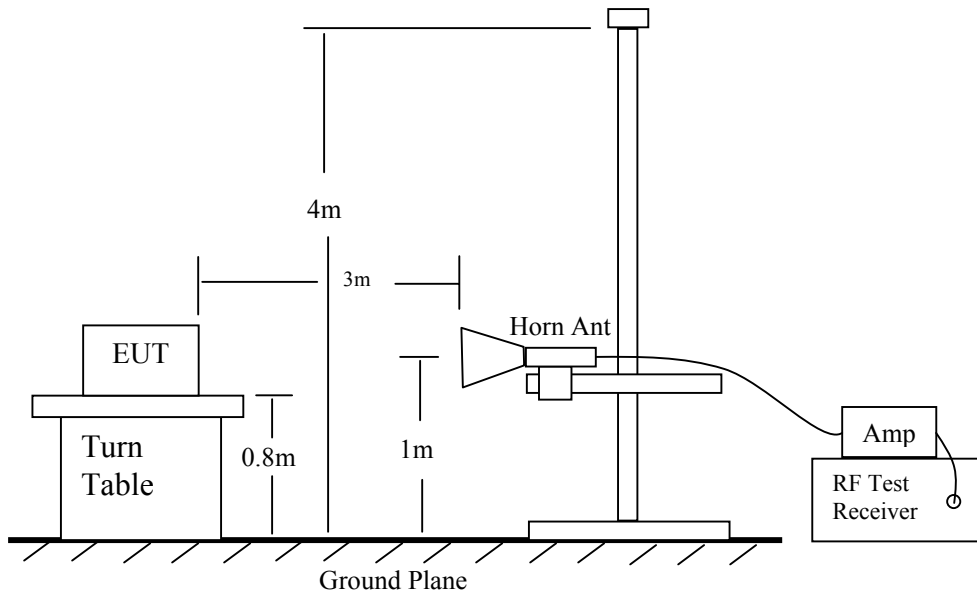

Radiated Emission Above 1000 MHz



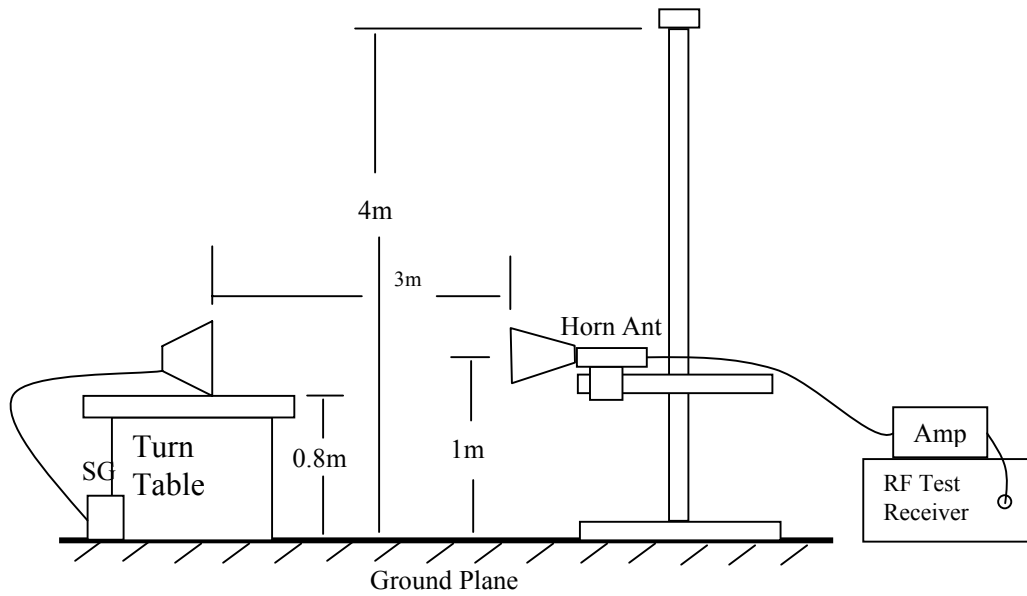
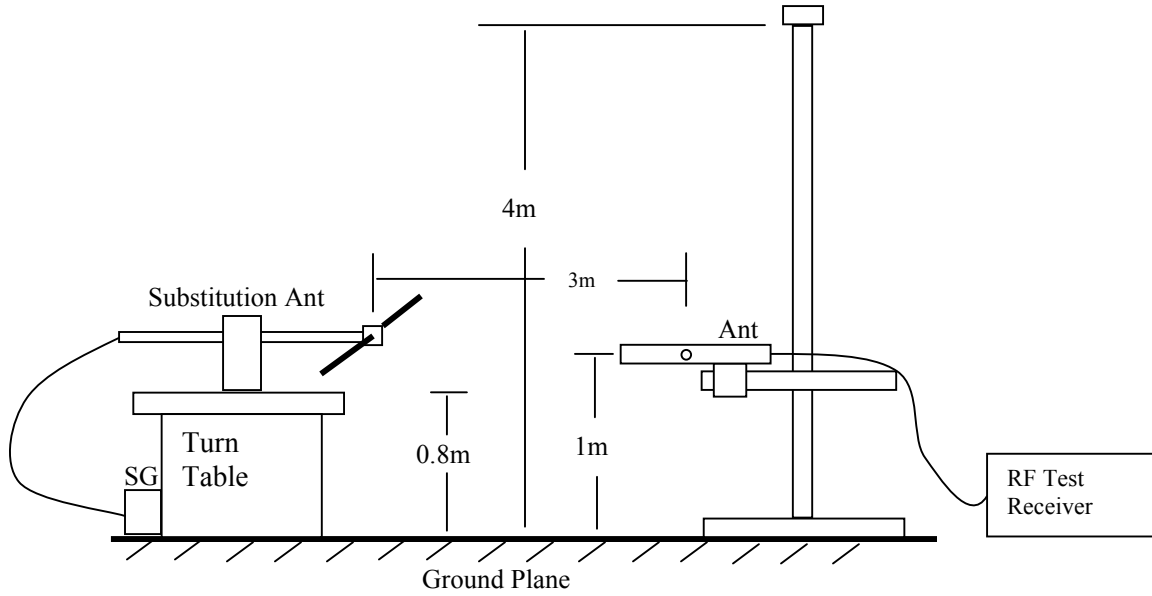

Radiated Emission – Substitution Method Set-up

**Radiated Emissions**

**X-Orientation**



**Y -Orientation**



Z-Orientation



**MEASUREMENT RESULT:**

Output Power (EIRP) at worst X-Position:

10/19/04 **High Frequency Measurement**  
 Compliance Certification Services, Morgan Hill Open Field Site

Test Engr: VIEN TRAN  
 Project #: 04U3020-1  
 Company: TRIMBLE NAVIGATION  
 EUT Descr.: ASSET TRACKER WITH GPS & GPRS  
 EUT M/N: TRIM TRAC - CLASS II PERMISSIVE CHANGE  
 Test Target: FCC 24  
 Mode Oper: TX\_ FUNDAMENTAL LOW, MID, HI CHANNELS\_ SUBSTITUTION

**Test Equipment:**

EMCO Horn 1-18GHz: T73; S/N: 6717 @3m  
 Horn > 18GHz: [Empty]  
 Limit: FCC 24  
 High Pass Filter

Hi Frequency Cables:  
 (2 ft)  (2 ~ 3 ft)  (4 ~ 6 ft)  (12 ft)

Pre-amplifier 1-26GHz: [Empty]  
 Pre-amplifier 26-40GHz: [Empty]

f GHz	SA reading (dBuV/m)	Ant. Pol. (H/V)	SG reading (dBm)	CL (dB)	Gain (dBi)	Gain (dBd)	EIRP (dBm)	Limit (dBm)	Margin (dB)	Notes
<b>WORST CASE AT X POSITION</b>										
<b>LOW CH</b>										
1.850	91.4	V	23.0	0.3	7.8	5.7	30.5	33.0	-2.5	
1.850	91.5	H	19.2	0.3	7.8	5.7	26.7	33.0	-6.3	
<b>MID CH</b>										
1.880	90.5	V	24.1	0.3	7.9	5.7	31.6	33.0	-1.4	
1.880	90.3	H	19.5	0.3	7.9	5.7	27.0	33.0	-6.0	
<b>HI CH</b>										
1.910	90.6	V	22.0	0.3	7.9	5.8	29.6	33.0	-3.4	
1.910	90.9	H	17.9	0.3	7.9	5.8	25.5	33.0	-7.5	

## 7.2. SECTION 2.1047: MODULATION CHARACTERISTICS

Not applicable.

## 7.3. SECTION 2.1049: OCCUPIED BANDWIDTH

### INSTRUMENTS LIST

EQUIPMENT	MANUFACTURE	MODEL NO.	SERIAL NO.	CAL. DUE DATE
PSA Analyzer	Agilent	E4446A	MY43360112	1/13/05
10dB Attenuator	Agilent	8493C	59028	N/A
DC Power Supply	Kenwood	PA36-3A	7060074	N/A

### TEST PROCEDURE

The EUT's output RF connector was connected with a short cable to the spectrum analyzer, RES BW was set to about 1% of emission BW, -26 dBc display line was placed on the screen, the occupied BW is the delta frequency between the two points where the display line intersects the signal trace. 26dB BW was measured for low, middle and high channels.

### TEST SETUP

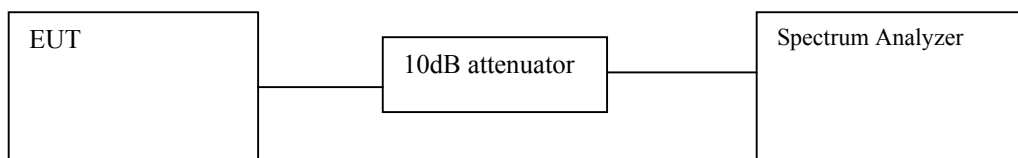

### RESULT

Channel	Frequency (MHz)	-26dBc BW (KHz)
Low	1850.2	269.288
Middle	1880.0	282.096
High	1909.8	268.806

### Low Channel

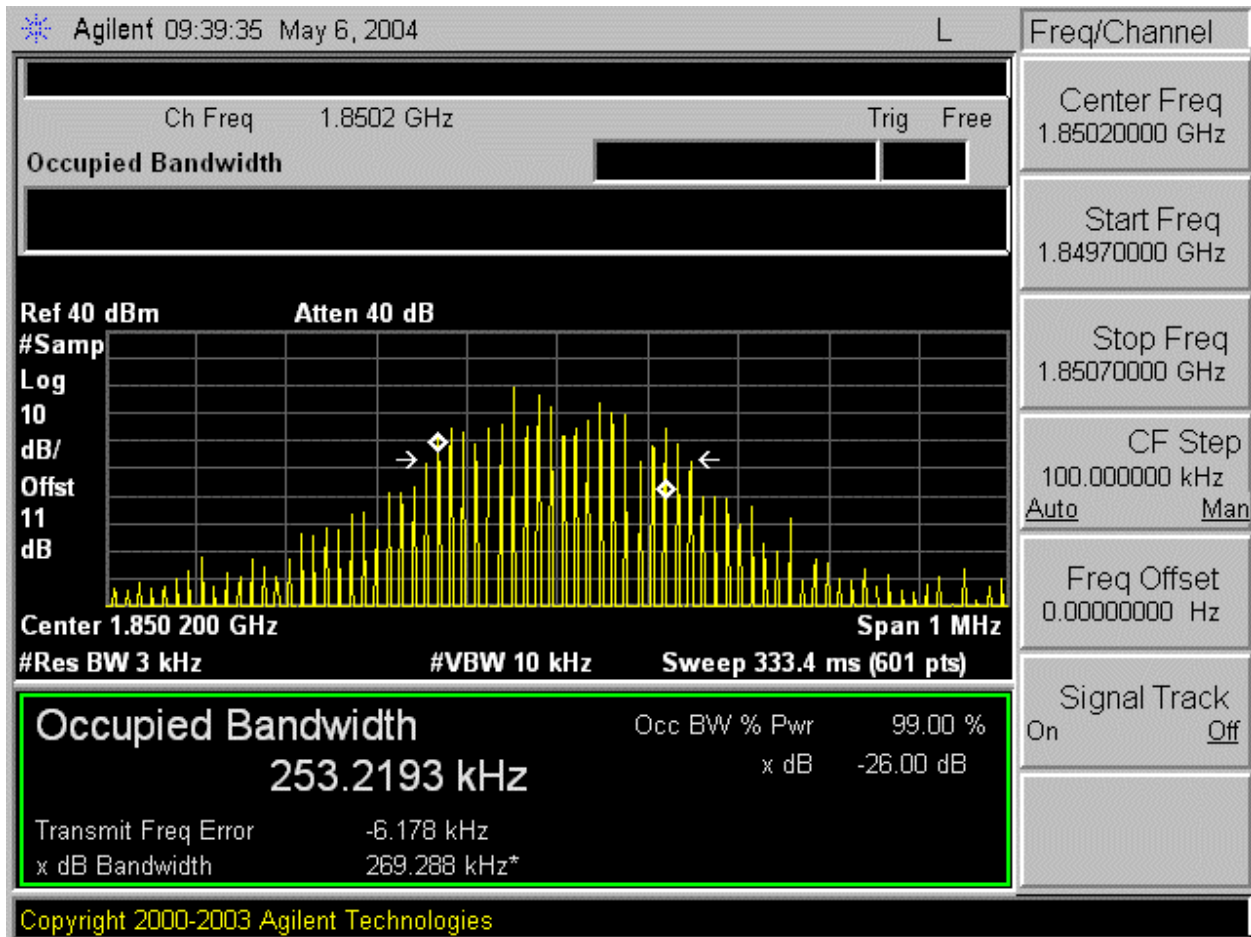

### Mid Channel

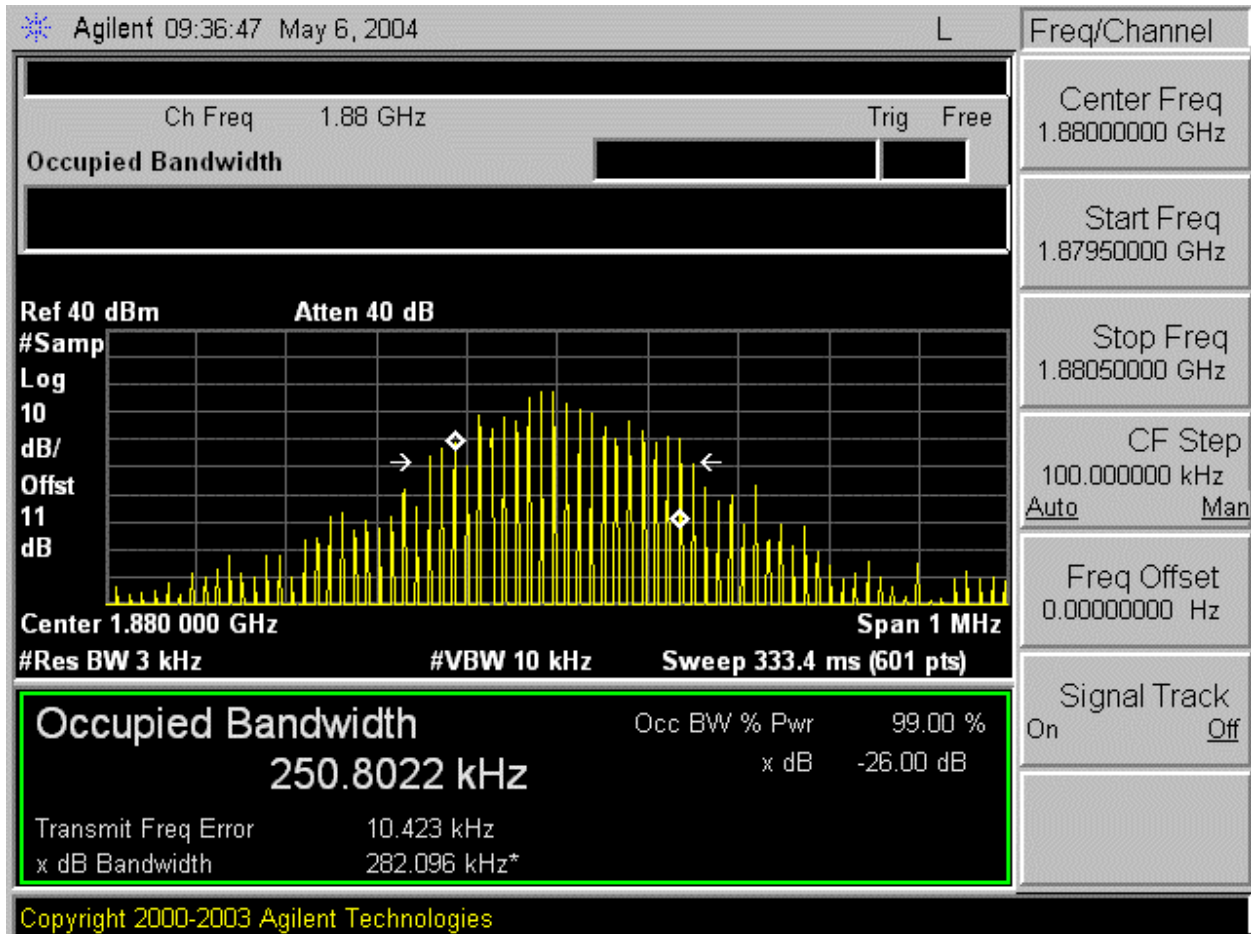



### High Channel

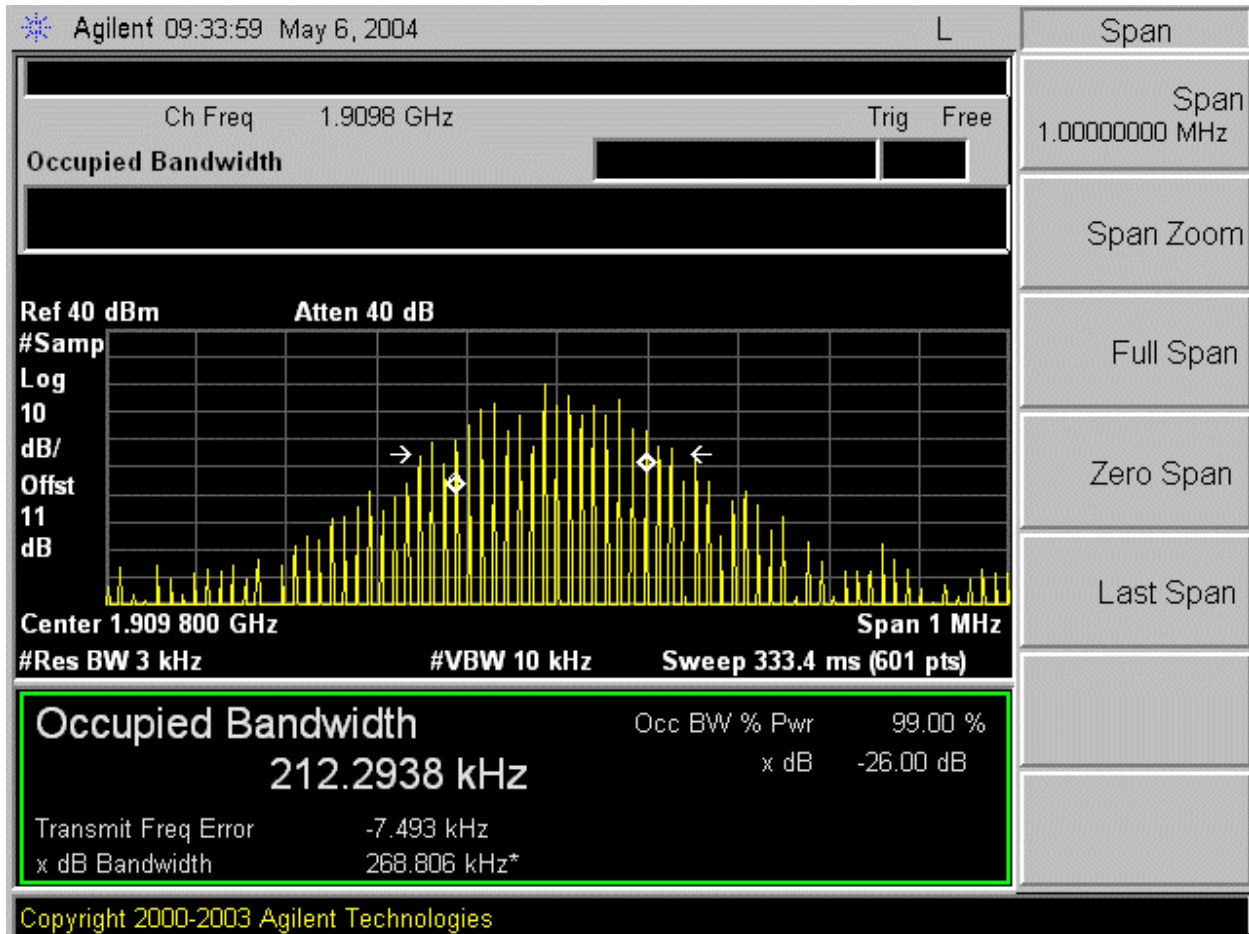

## 7.4. SECTION 2.1051: SPURIOUS EMISSION AT ANTENNA TERMINAL

### INSTRUMENTS LIST

EQUIPMENT	MANUFACTURE	MODEL NO.	SERIAL NO.	CAL. DUE DATE
PSA Analyzer	Agilent	E4446A	MY43360112	1/13/05
10dB Attenuator	Agilent	8493C	59028	N/A
DC Power Supply	Kenwood	PA36-3A	7060074	N/A

### TEST SETUP

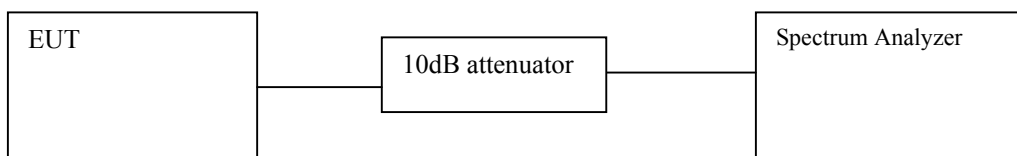

### TEST PROCEDURE

- 1) EUT's RF output connector (made solely for the purpose of the test) is connected to the spectrum analyzer, and set as close as possible to the bottom of the block edge and one set as close as possible to the top of the block edge. Set the RES BW to 1% of the emission bandwidth to show compliance with the  $-13\text{dBm}$  limit, in the 1 MHz bands immediately outside and adjacent to the top and bottom edges of the frequency block.
- 2) For the Out-of-Band measurements a 1 MHz RES BW was used to scan from 15 MHz to  $10 \times f_0$  of the fundamental carrier for all frequency block. A display line was placed at  $-13\text{dBm}$  to show compliance for spurious, and harmonics.

### MEASUREMENT RESULT:

Low / High Band Edges, Low / Mid / High Out-Of-Band Emissions:

Low Band Edge- Ch 512 (Low Channel)

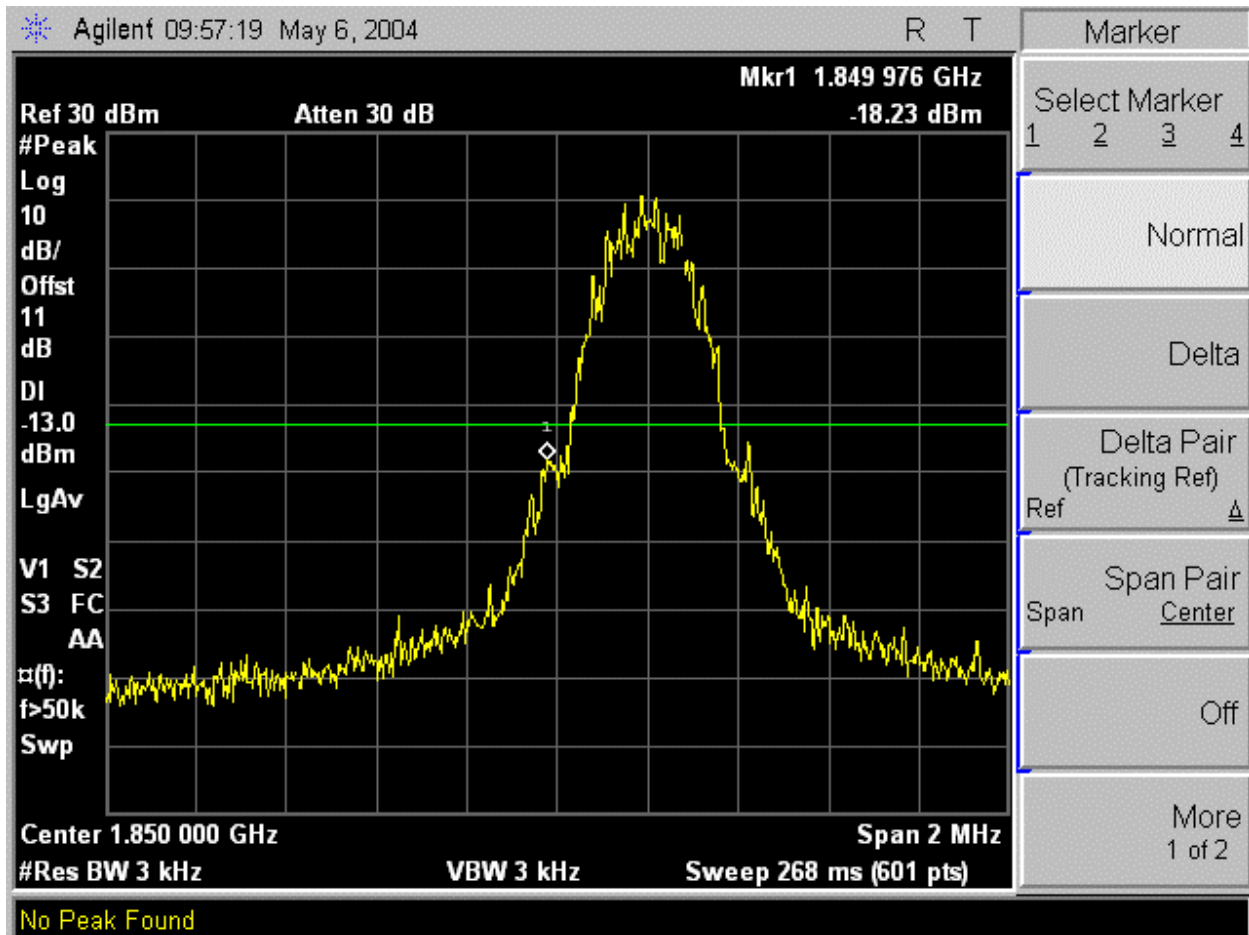

High Band Edge- Ch 810 (High Channel)

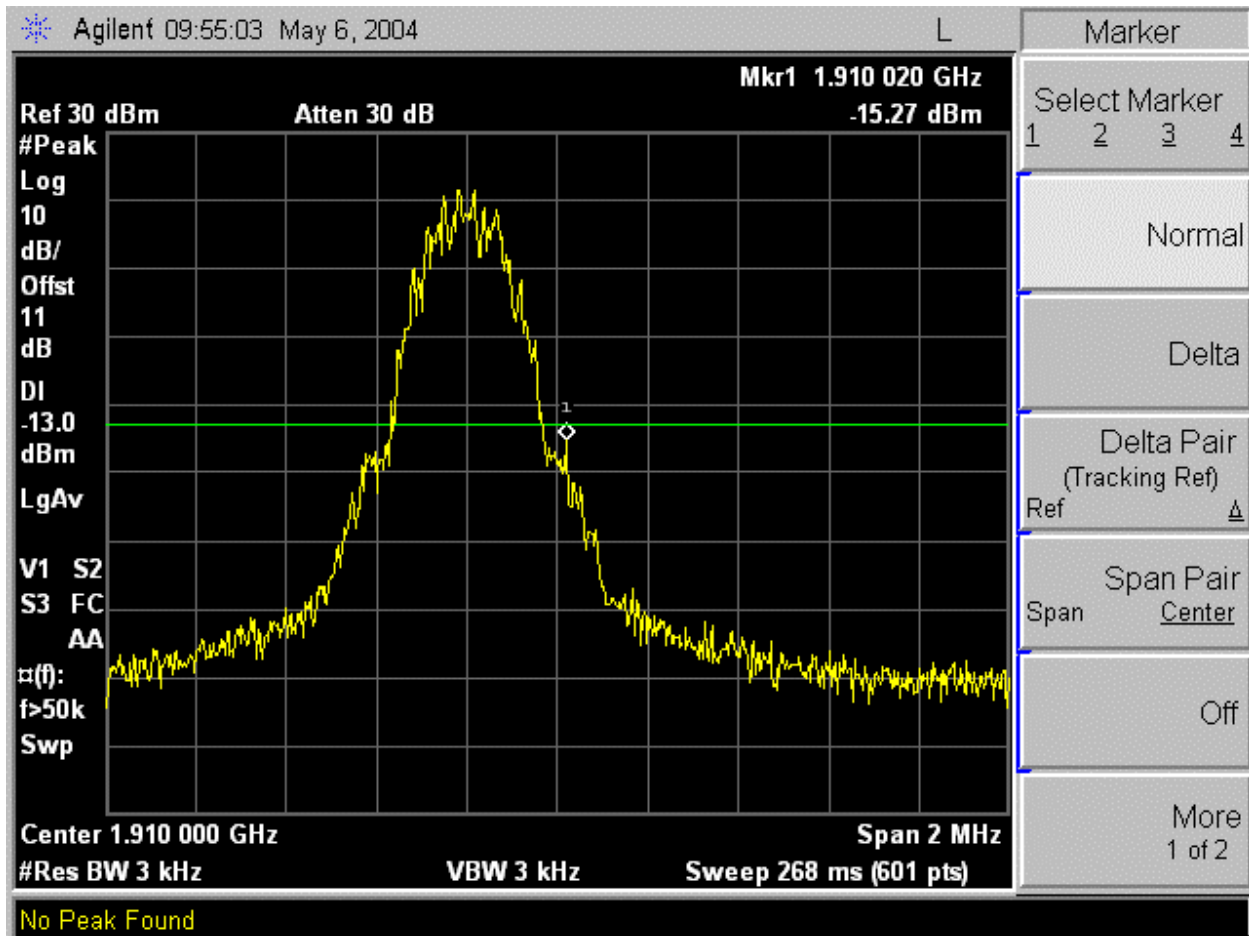

Out-Of-Band Emissions-Low Channel

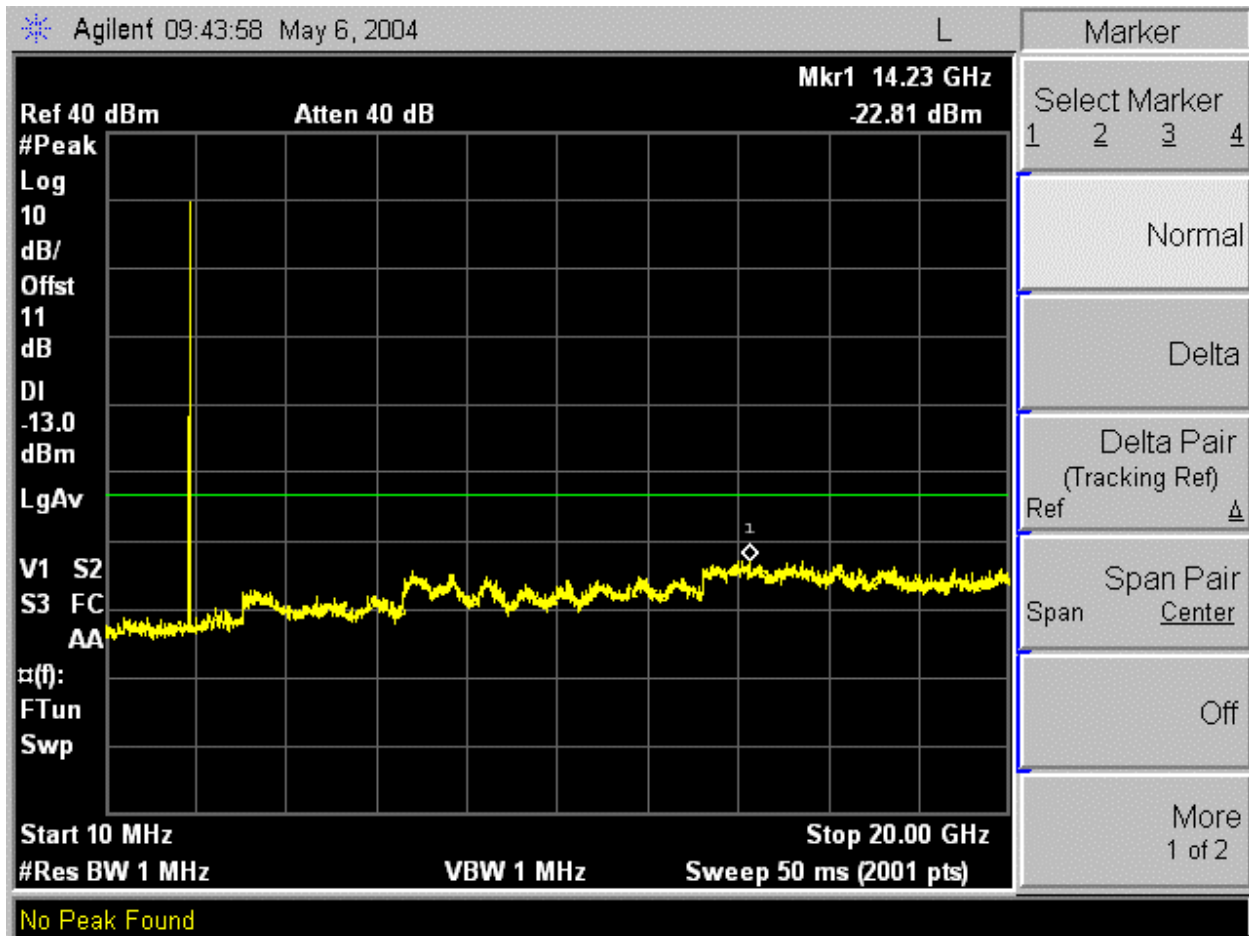

Out-Of-Band Emissions-Mid Channel

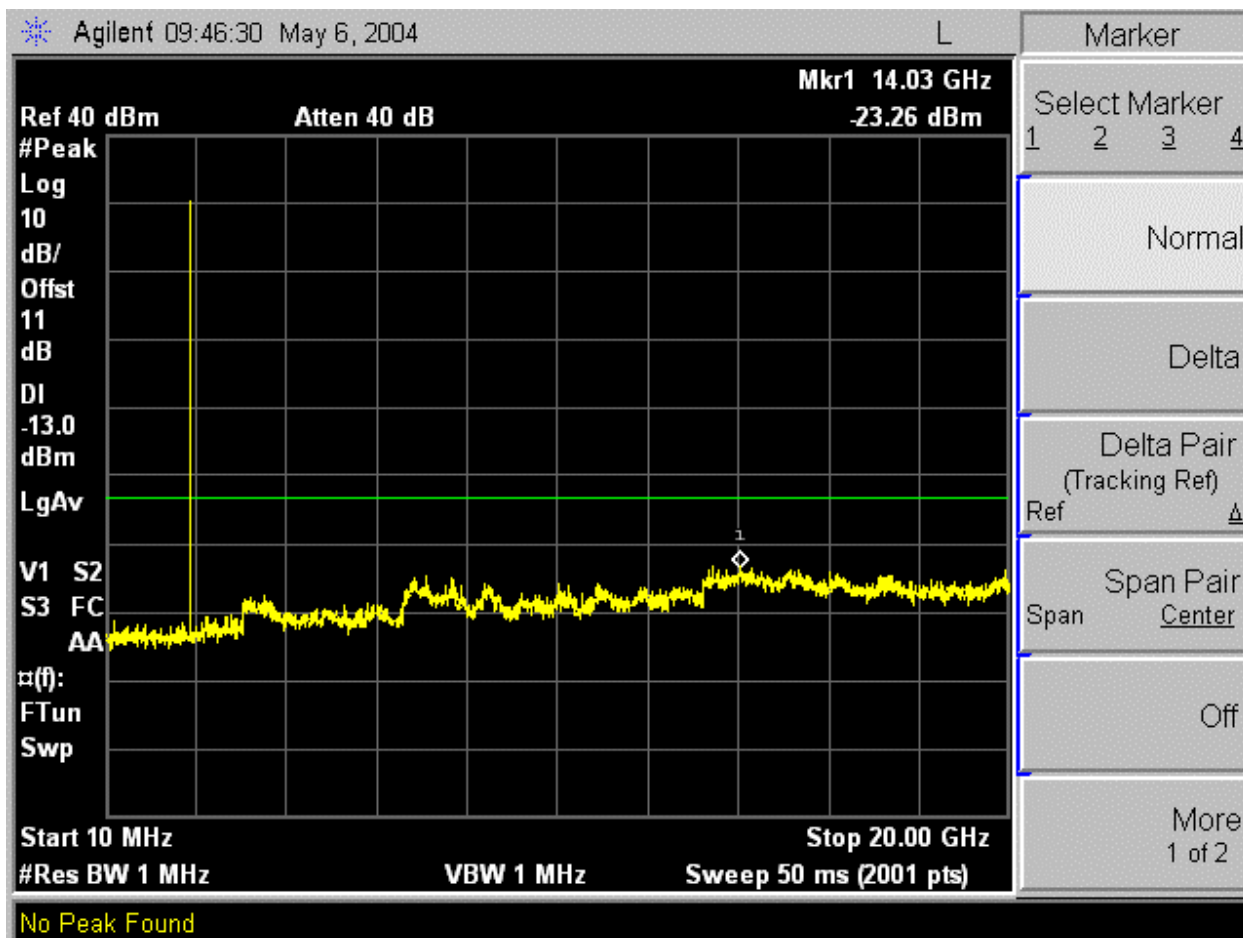

Out-Of-Band Emissions-High Channel

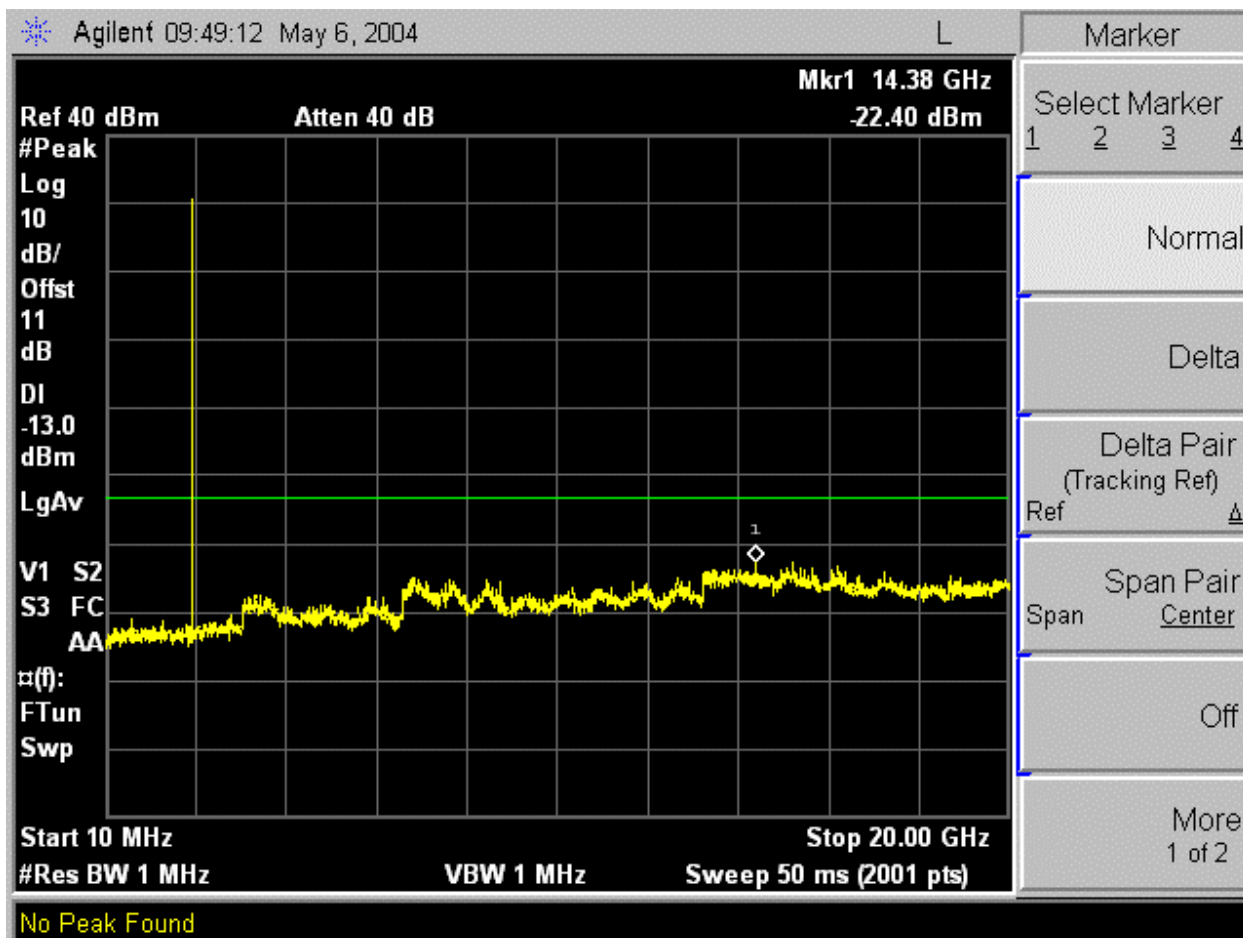

**7.5. SECTION 2.1053: FIELD STRENGTH OF SPURIOUS RADIATION**

**INSTRUMENTS LIST**

EQUIPMENT	MANUFACTURE	MODEL NO.	SERIAL NO.	CAL. DUE DATE
PSA Analyzer	Agilent	E4446A	MY43360112	1/13/05
DC Power Supply	Kenwood	PA36-3A	7060074	N/A
30MHz--- 2Ghz	Sunol Sciences	JB1 Antenna	A121003	12/22/2004
Tune Dipole	ETS	DB-4	1629	5/14/05
Tx Horn Antenna	EMCO	3115	6739	2/4/2005
Rx Horn Antenna	EMCO	3115	6717	2/4/2005
Amplifier	MITEQ	NSP2600-SP	924342	4/25/2005
HPF	MICROLAB	FH-2400H	N/A	N/A

**Detector Function Setting of Test Receiver**

Frequency Range (MHz)	Detector Function	Resolution Bandwidth	Video Bandwidth
Above 1000	<input checked="" type="checkbox"/> Peak <input type="checkbox"/> Average	<input checked="" type="checkbox"/> 1 MHz <input type="checkbox"/> 1 MHz	<input checked="" type="checkbox"/> 1 MHz <input type="checkbox"/> 10 Hz



**TEST SETUP**

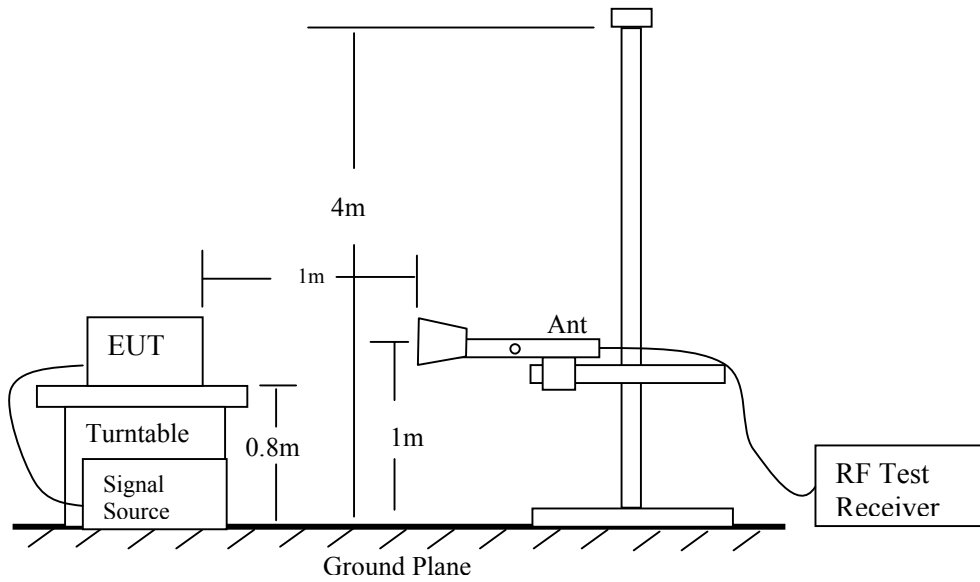

Radiated Emission Measurement

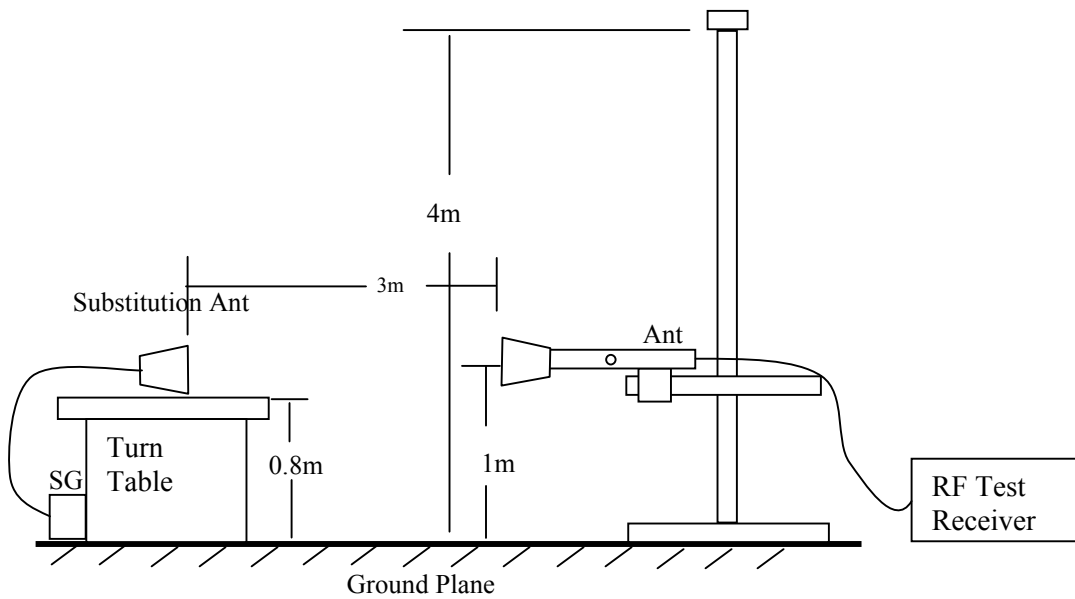

Radiated Emission – Substitution Method set-up

### **TEST PROCEDURE**

- 1). On a test site, the EUT shall be placed on a turntable, and in the position closest to the normal use as declared by the user.
- 2). The test antenna shall be oriented initially for vertical polarization located 1m from the EUT to correspond to the frequency of the transmitter.
- 3). The output of the test antenna shall be connected to the measuring receiver and either a peak or average detector was used for the measurement as indicated on the report. The detector selection is based on how close the emission level was approaching the limit.
- 4). The transmitter shall be switched on, if possible, without the modulation and the measurement receiver shall be tuned to the frequency of the transmitter under test.
- 5). The test antenna shall be raised and lowered through the specified range of height until a maximum signal level is detected by the measuring receiver.
- 6). The transmitter shall then be rotated through 360° in the horizontal plane, until the maximum signal level is detected by the measuring receiver.
- 7). The test antenna shall be raised and lowered again through the specified range of height until a maximum signal level is detected by the measuring receiver.
- 8). The maximum signal level detected by the measuring receiver shall be noted.
- 9). The transmitter shall be replaced by a substitution antenna.
- 10). The substitution antenna shall be oriented for vertical polarization.
- 11). The substitution antenna shall be connected to a calibrated signal generator.
- 12). If necessary, the input attenuator setting of the measuring receiver shall be adjusted in order to increase the sensitivity of the measuring receiver.
- 13). The test antenna shall be raised and lowered through the specified range of the height to ensure that the maximum signal is received.
- 14). The input signal to the substitution antenna shall be adjusted to the level that produces a level detected by the measuring receiver, that is equal to the level noted while the transmitter radiated power was measured, corrected for the change of input attenuation setting of the measuring receiver.
- 15). The input level to the substitution antenna shall be recorded as power level in dBm, corrected for any change of input attenuator setting of the measuring receiver.
- 16). The measurement shall be repeated with the test antenna and the substitution antenna oriented for horizontal polarization.
- 17). The measure of the effective radiated power is the larger of the two levels recorded, at the input to the substitution antenna, corrected for the gain of the substitution antenna if necessary.

### **MEASUREMENT RESULT**

No non-compliance noted, as shown below

Radiated Emission Setup Photos – Worst case: EUT at X position



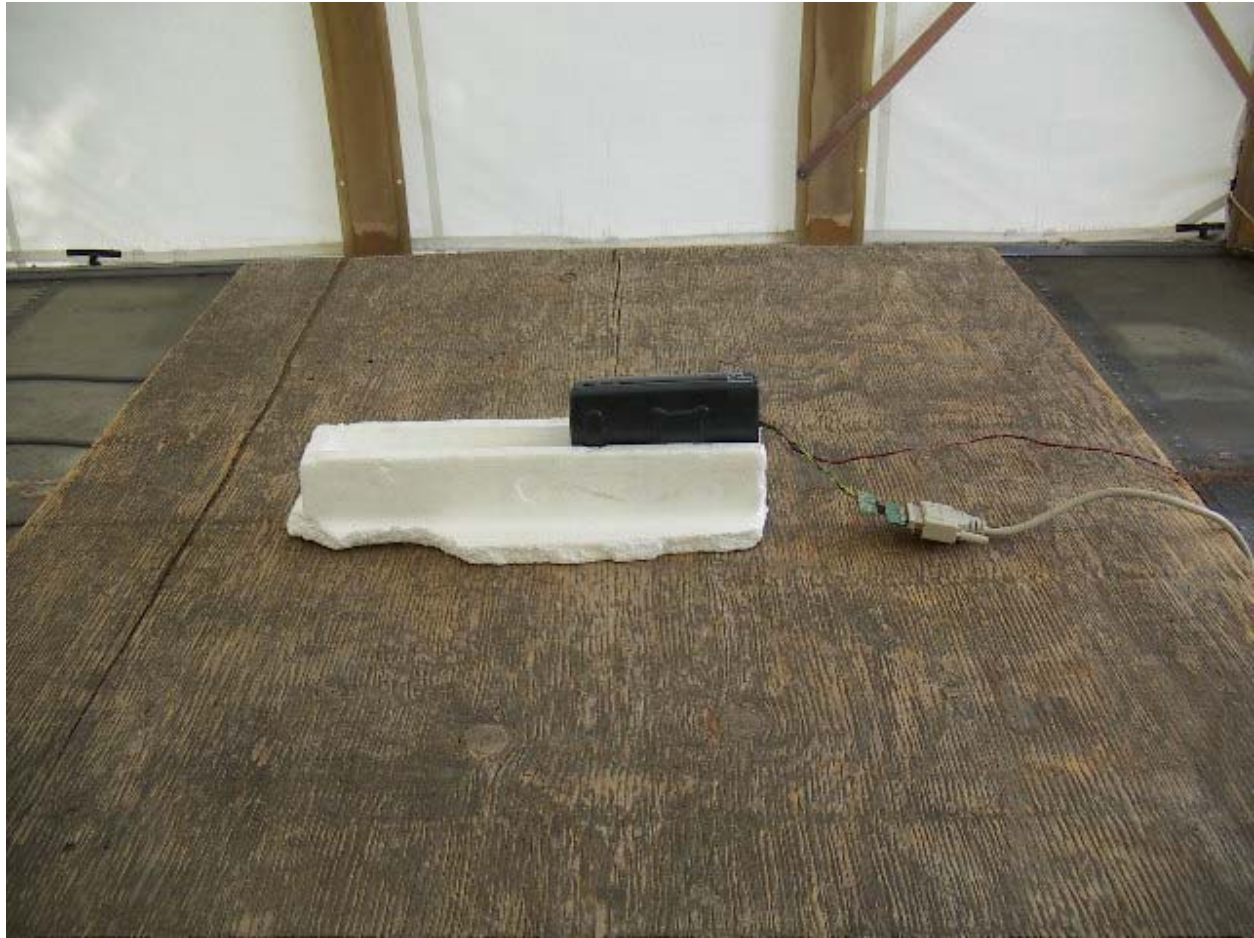

Harmonics & Spurious Emissions: Low, Mid, & High Channels:

Above 1GHz:

f GHz	SA reading (dBuV/m)	Ant. Pol. (H/V)	SG reading (dBm)	CL (dB)	Gain (dBi)	Gain (dBd)	EIRP (dBm)	Limit (dBm)	Margin (dB)	Notes
<b>10/19/04 High Frequency Measurement Above 1GHz</b>										
<b>Compliance Certification Services, Morgan Hill Open Field Site</b>										
Test Engr: VIEN TRAN										
Project #: 04U3020-1										
Company: TRIMBLE NAVIGATION										
EUT Descr.: ASSET TRACKER WITH GPS & GPRS										
EUT M/N: TRIM TRAC - CLASS II PERMISSIVE CHANGE										
Test Target: FCC 24										
Mode Oper: TX_HARMONIC & SPUR_SUBSTITUTION_LOW, MID, HI CHANNELS										
<b>Test Equipment:</b>										
EMCO Horn 1-18GHz T60; S/N: 2238 @3m		Horn > 18GHz		Limit FCC 24		<input checked="" type="checkbox"/> High Pass Filter				
Hi Frequency Cables <input checked="" type="checkbox"/> (2 ft) <input type="checkbox"/> (2~3 ft) <input type="checkbox"/> (4~6 ft) <input checked="" type="checkbox"/> (12 ft)				Pre-amplifier 1-26GHz T87 Miteq 924342		Pre-amplifier 26-40GHz				
<b>WORST CASE AT X POSITION</b>										
<b>LOW CH 512, 1850.20MHz</b>										
3.700	84.2	V	-20.5	3.2	9.5	7.3	-14.2	-13.0	-1.2	
5.550	78.6	V	-22.9	4.2	11.1	9.0	-16.0	-13.0	-3.0	
7.400	70.5	V	-27.0	5.3	11.2	9.1	-21.0	-13.0	-8.0	
9.251	51.0	V	-42.5	6.4	10.8	8.7	-38.0	-13.0	-25.0	
3.700	80.2	H	-24.4	3.2	9.5	7.3	-18.1	-13.0	-5.1	
5.550	65.0	H	-35.5	4.2	11.1	9.0	-28.6	-13.0	-15.6	
7.400	67.0	H	-29.7	5.3	11.2	9.1	-23.7	-13.0	-10.7	
9.251	61.0	H	-32.5	6.4	10.8	8.7	-28.0	-13.0	-15.0	
<b>MID CH 661, 1880MHz</b>										
3.760	84.0	V	-20.6	3.2	9.5	7.4	-14.3	-13.0	-1.3	
5.640	80.0	V	-21.4	4.2	11.2	9.0	-14.4	-13.0	-1.4	
7.520	74.0	V	-23.2	5.4	11.2	9.1	-17.3	-13.0	-4.3	
9.400	59.0	V	-34.3	6.4	11.0	8.9	-29.7	-13.0	-16.7	
3.760	82.9	H	-21.6	3.2	9.5	7.4	-15.3	-13.0	-2.3	
5.640	67.0	H	-33.4	4.2	11.2	9.0	-26.4	-13.0	-13.4	
7.520	65.9	H	-30.5	5.4	11.2	9.1	-24.6	-13.0	-11.6	
9.400	61.0	H	-32.3	6.4	11.0	8.9	-27.7	-13.0	-14.7	
<b>HI CH 810, 1909.80MHz</b>										
3.820	81.0	V	-23.4	3.3	9.5	7.4	-17.2	-13.0	-4.2	
5.730	79.0	V	-22.2	4.2	11.2	9.1	-15.3	-13.0	-2.3	
7.630	75.0	V	-21.9	5.4	11.2	9.1	-16.1	-13.0	-3.1	
9.549	58.0	V	-35.2	6.4	11.2	9.1	-30.4	-13.0	-17.4	
3.820	78.9	H	-25.5	3.3	9.5	7.4	-19.2	-13.0	-6.2	
5.730	67.6	H	-32.6	4.2	11.2	9.1	-25.7	-13.0	-12.7	
7.630	70.4	H	-25.7	5.4	11.2	9.1	-19.9	-13.0	-6.9	
9.549	52.0	H	-41.2	6.4	11.2	9.1	-36.4	-13.0	-23.4	
GPRS mode readings same as GPS readings										
No other emissions were found up to 10th harmonic										

Worst TX Channel 30-1000MHz:

10/20/04 30-1000MHz Frequency Measurement										
Compliance Certification Services, Morgan Hill Open Field Site										
Test Engr: VIEN TRAN										
Project #: 04U3020-2										
Company: TRIMBLE NAVIGATION										
EUT Descrip.: ASSET TRACKER WITH GPS & GPRS										
EUT M/N: TRIM TRAC - CLASS II PERMISSIVE CHANGE										
Test Target: FCC 24										
Mode Oper: TX_ 30 TO 1000MHz_ SUBSTITUTION										
Test Equipment:										
Bilog Antenna		Cable		Pre-amplifer 8447D		Limit				
5m Chamber Sunol Bilog		5m Chamber Cable				EIRP				
f MHz	SA reading (dBuV/m)	Ant. Pol (H/V)	SG reading (dBm)	CL (dB)	Gain (dBi)	Gain (dBd)	EIRP (dBm)	Limit (dBm)	Margin (dB)	Notes
36.79	20.0	H	-56.8	1.0	-14.6	-16.7	-72.4	-13.0	-59.4	
97.90	28.4	H	-56.0	1.3	-0.8	-2.9	-58.1	-13.0	-45.1	
150.28	26.0	H	-55.2	1.6	0.4	-1.7	-56.4	-13.0	-43.4	
174.53	22.9	H	-59.0	1.7	2.6	0.4	-58.1	-13.0	-45.1	
249.22	31.8	H	-50.2	1.9	6.1	3.9	-46.1	-13.0	-33.1	
474.26	13.4	H	-62.3	2.6	6.1	4.0	-58.8	-13.0	-45.8	
31.49	8.4	V	-68.2	0.9	-18.4	-20.5	-87.5	-13.0	-74.5	
100.81	30.8	V	-51.7	1.3	-1.0	-3.2	-54.1	-13.0	-41.1	
173.56	27.7	V	-55.0	1.7	2.5	0.4	-54.2	-13.0	-41.2	
243.40	33.7	V	-48.4	1.9	6.0	3.9	-44.3	-13.0	-31.3	
255.04	34.5	V	-47.6	1.9	6.1	3.9	-43.4	-13.0	-30.4	
332.64	21.0	V	-58.5	2.2	6.0	3.9	-54.6	-13.0	-41.6	
NO OTHER EMISSIONS WERE DETECTED UP TO 1GHz										

## 7.6. SECTION 2.1055: FREQUENCY STABILITY

### INSTRUMENTS LIST

EQUIPMENT	MANUFACTURE	MODEL NO.	SERIAL NO.	CAL. DUE DATE
PSA Analyzer	Agilent	E4446A	MY43360112	1/13/05
10dB Attenuator	Agilent	8493C	59028	N/A
Environmental Chamber	Thermotron	SE 600-10-10	2980	4/23/05
DC Power Supply	Kenwood	PA36-3A	7060074	N/A

### DETECTOR SETTING OF TEST RECEIVER

Frequency Range (MHz)	Detector Function	Resolution Bandwidth	Video Bandwidth
Above 1000	Peak	300 Hz	300 Hz

### TEST SETUP

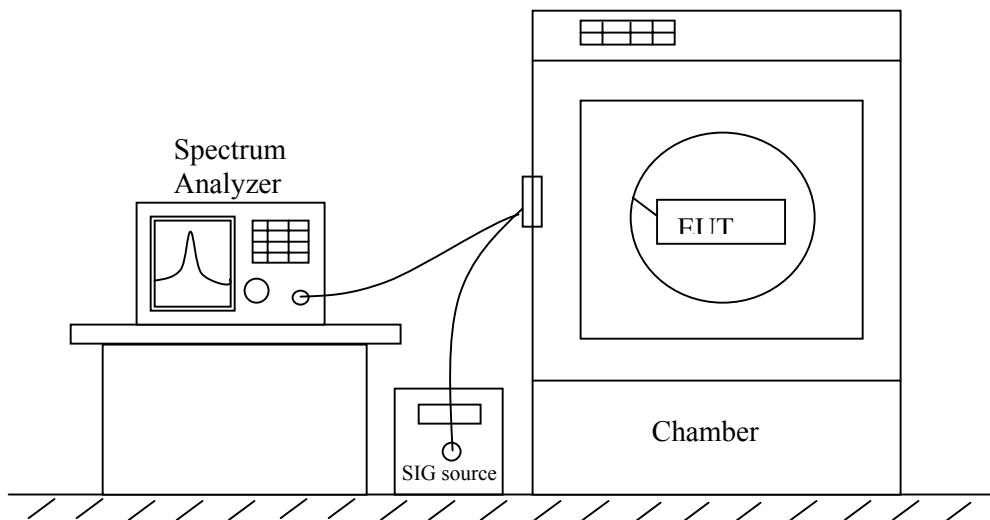

Frequency Stability Setup

## **TEST PROCEDURE**

- **Frequency stability versus environmental temperature**

- 1). Setup the configuration per figure 6 for frequencies measurement inside the environmental chamber. Set the temperature of the chamber to 25°C. Set SA Resolution Bandwidth low enough to obtain the desired frequency resolution and measure the EUT 25°C operating frequency as reference frequency.
- 2). Turn EUT off and set Chamber temperature to -30°C.
- 3). Allow sufficient time (approximately 20 to 30 minus after chamber reach the assigned temperature) for EUT to stabilize. Turn on EUT and measure the EUT operating frequency. Turn off EUT after the measurement.
- 4). Repeat step 3 with a 10°C increased per stage until the highest temperature of +50°C reached, record all measured frequencies on each temperature step.

- **Frequency stability versus AC input voltage**

- 1). Setup the configuration per figure 6 and set chamber temperature to 25°C. Use a variable AC power supply to power the EUT and set AC output voltage to EUT nominal input AC voltage. Set SA Resolution Bandwidth low enough to obtain the desired frequency resolution and measure the EUT 25°C operating frequency as reference frequency.
- 2). Slowly reduce the EUT input voltage to specified extreme voltage variation ( $\pm 15\%$ ) and record the maximum frequency change.

## **MEASUREMENT RESULT**

*No non-compliance noted, as shown below.*





Reference Frequency: GPS & GRPS Mid Channel 1880.00000MHz @ 25°C				
Limit: to stay $\pm 2.5$ ppm = 4700.040 Hz				
Power Supply (Vdc)	Environment Temperature (°C)	Frequency Deviation Measured with Time Elapse		
		(MHz)	Delta (ppm)	Limit (ppm)
3.60	50	1880.01629	-0.146	$\pm 2.5$
3.60	40	1880.01620	-0.095	$\pm 2.5$
3.60	30	1880.01616	-0.074	$\pm 2.5$
<b>3.60</b>	<b>25</b>	<b>1880.01602</b>	<b>0</b>	<b><math>\pm 2.5</math></b>
3.60	20	1880.01599	0.014	$\pm 2.5$
3.60	10	1880.01582	0.109	$\pm 2.5$
3.60	0	1880.01554	0.255	$\pm 2.5$
3.60	-10	1880.01524	0.414	$\pm 2.5$
3.60	-20	1880.01560	0.223	$\pm 2.5$
3.60	-30	1880.01572	0.159	$\pm 2.5$
2.85 - 3.00 (end point)	25	1880.01608	-0.030	$\pm 2.5$
4.14	25	1880.01605	-0.019	$\pm 2.5$