



ANSI C63.19-2007

FCC HAC TEST REPORT

For

PDA

Model: TNJ32

Trade Name: Trimble

Issued to

Trimble Navigation Ltd.

935 Stewart Drive, Sunnyvale, CA 94088-3642 U.S.A.

Issued by

**Compliance Certification Services Inc.
No. 11, Wugong 6th Rd., Wugu Industrial Park,
Taipei Hsien, 248 Taiwan.
<http://www.ccsrf.com>
service@ccsrf.com**



Issued Date: January 15, 2012

Note: This report shall not be reproduced except in full, without the written approval of Compliance Certification Services Inc. This document may be altered or revised by Compliance Certification Services Inc. personnel only, and shall be noted in the revision section of the document.



Revision History

Rev.	Issue Date	Revisions	Effect Page	Revised By
00	January 15, 2012	Initial Issue	ALL	Peach Chang

Note: This report shall not be reproduced except in full, without the written approval of Compliance Certification Services Inc. This document may be altered or revised by Compliance Certification Services Inc. personnel only, and shall be noted in the revision section of the document.



TABLE OF CONTENTS

1.	HEARING AID COMPATIBILITY CERTIFICATE.....	4
2.	EQUIPMENT UNDER TEST DESCRIPTION AND TEST SUMMARY	5
3.	REQUIREMENTS FOR COMPLIANCE TESTING DEFINED BY THE FCC	6
4.	SYSTEM DESCRIPTION.....	7
	4.1 MEASUREMENT SYSTEM DIAGRAM.....	7
5.	SYSTEM COMPONENTS.....	8
	5.1 DASY4 MEASUREMENT SERVER	8
	5.2 DATA ACQUISITION ELECTRONICS (DAE)	8
	5.3 ER3DV6 ISOTROPIC E-FIELD PROBE FOR GENERAL NEAR-FILED MEASUREMENTS	8
	5.4 H3DV6 ISOTROPIC E-FIELD PROBE FOR GENERAL NEAR-FILED MEASUREMENTS.....	9
	5.5 LIGHT BEAM UNIT	9
	5.6 TEST ARCH	9
	5.7 PHONE POSITIONER	10
	5.8 SYSTEM VALIDATION KITS	10
	5.9 SOFTWARE HAC V4.5	10
6.	EVALUATION PROCEDURES	11
7.	MEASUREMENT UNCERTAINTY	12
8.	TEST PROCEDURES	13
9.	PERFORMANCE	15
	9.1 ARTICULATION WEIGHTING FACTOR (AWF)	15
	9.2 TELEPHONE N-FILED CATEGORY	15
10.	MEASUREMENT RESULTS.....	16
	10.1SYSTEM CHECK.....	16
	10.2DIPOLE VALIDATION.....	16
	10.3EUT TUNE-UP PROCEDURES	20
	10.4HAC MEASUREMENT RESULTS	22
11.	EUT PHOTO	24
12.	EQUIPMENT LIST & CALIBRATION STATUS.....	24
13.	LOCATION OF TEST SITE	26
14.	ATTACHMENTS	26



1. HEARING AID COMPATIBILITY CERTIFICATE

Applicant: Trimble Navigation Ltd.
 935 Stewart Drive, Sunnyvale, CA 94088-3642 U.S.A

Equipment Under Test: PDA

Trade Name: Trimble

Model Number: TNJ32

Date of Test: January 8, 2012

APPLICABLE STANDARDS	
STANDARD	TEST RESULT
ANSI C63.19-2007 (8 June, 2007)	No non-compliance noted
HAC RATE CATEGORY	
M3 (RF EMISSION)	

The device was tested by Compliance Certification Services Inc. in accordance with the measurement methods and procedures specified in ANSI C63.19-2007. The test results in this report apply only to the tested sample of the stated device/equipment. Other similar device/equipment will not necessarily produce the same results due to production tolerance and measurement uncertainties.

Reviewed by:

Tested by

Jason Lin
 Section Manager
 Compliance Certification Services Inc.

Anson Lu
 Test Engineer
 Compliance Certification Services Inc



2. EQUIPMENT UNDER TEST DESCRIPTION AND TEST SUMMARY

Product	PDA
Trade Name	Trimble
Model Number	TNJ32
Model Discrepancy	N/A
Frequency Range	GSM850 : 824 MHz ~ 849 MHz GSM1900 : 1850 MHz ~ 1910 MHz WCDMA Band V : 824 MHz ~ 849 MHz WCDMA Band II : 1850 MHz ~ 1910 MHz WCDMA Band IV: 1712.4 ~ 1752.6 MHz
Transmit Power (Average/dBm)	850 Band: GSM 850: 32.82 dBm WCDMA band V: 23.71 dBm 1900 Band: GSM 1900: 28.80 dBm WCDMA band II: 23.63 dBm WCDMA band IV: 24.34 dBm
Max. E-field / H-field EMISSION:	GSM850 band: E-Field: 130.5 V/m -M4 Phone H-Field: 0.152 A/m-M4 Phone GSM1900 band: E-Field: 18.6 V/m -M4 Phone H-Field: 0.065 A/m-M4 Phone WCDMA band II: E-Field: 8.80 V/m -M4 Phone H-Field: 0.023 A/m-M4 Phone WCDMA band IV: E-Field: 11.4 V/m -M4 Phone H-Field: 0.027 A/m-M4 Phone WCDMA band V: E-Field: 48.9 V/m -M4 Phone H-Field: 0.068 A/m-M4 Phone
Modulation Technique	GSM / PCS: GMSK WCDMA: QPSK
Antenna Specification	WWAN antenna type: PIFA antenna
Battery	Model: 707-00008-00A, Rating: 3.7VDC, 3060mAh, 11.32Wh

Remark: The sample selected for test was production product and was provided by manufacturer.



3. REQUIREMENTS FOR COMPLIANCE TESTING DEFINED BY THE FCC

In July 2003, the Federal Communications Commission (FCC) modified the exemption for wireless phones under the Hearing Aid Compatibility Act of 1988 to require that wireless phone manufacturers and wireless phone service providers make digital wireless phones accessible to individuals who use hearing aids.

Since 2003, more people have come to rely on wireless phones for safety, business, and personal uses. For these reasons, it is vital for individuals with a hearing impairment have access to digital wireless phones. The FCC has taken steps to increase access to wireless telephones by requiring wireless carriers and equipment manufacturers to make more digital wireless phones hearing aid-compatible.

In June 2005, the FCC reaffirmed the timetable for the development and sale of digital wireless phones that are compatible with hearing aids. Specifically, the rules are as follows:

The FCC also encourages digital wireless phone manufacturers and service providers to offer at least one compliant handset that is a lower-priced model and one that has higher-end features and encourages hearing-aid manufacturers to label their pre-customization products according to the ANSI standard.

4. SYSTEM DESCRIPTION

4.1 MEASUREMENT SYSTEM DIAGRAM

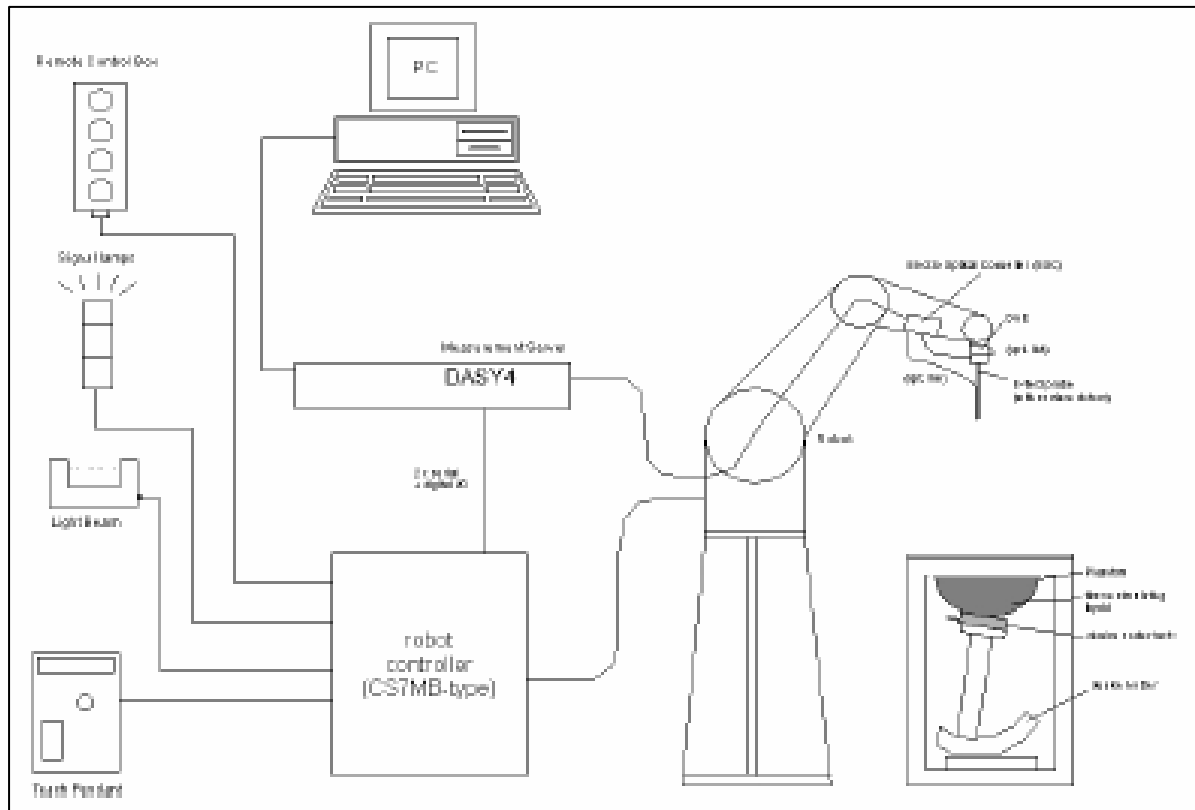

Figure 1: Measurement System diagram

The DASYS4 system for performing compliance tests consists of the following items:

- A standard high precision 6-axis robot (Stäubli RX family) with controller, teach pendant and software. An arm extension for accommodating the data acquisition electronics (DAE).
- A dosimetric probe, i.e., an isotropic E-field probe optimized and calibrated for usage in tissue simulating liquid. The probe is equipped with an optical surface detector system.
- A data acquisition electronics (DAE) which performs the signal amplification, signal multiplexing, AD-conversion, offset measurements, mechanical surface detection, collision detection, etc. The unit is battery powered with standard or rechargeable batteries. The signal is optically transmitted to the EOC.
- The Electro-optical converter (EOC) performs the conversion between optical and electrical of the signals for the digital communication to the DAE and for the analog signal from the optical surface detection. The EOC is connected to the measurement server.
- The function of the measurement server is to perform the time critical tasks such as signal filtering, control of the robot operation and fast movement interrupts.
- A probe alignment unit which improves the (absolute) accuracy of the probe positioning.
- A computer operating Windows 2000 or Windows XP.
- DASYS4 software.
- Remote control with teach pendant and additional circuitry for robot safety such as warning lamps, etc.
- The SAM twin phantom enabling testing left-hand and right-hand usage.
- Validation dipole kits allowing validating the proper functioning of the system.

5. SYSTEM COMPONENTS

5.1 DASY4 MEASUREMENT SERVER



Figure 2:DASY4 Server

The DASY4 measurement server is based on a PC/104 CPU board with a 166MHz low-power Pentium, 32MB chip disk and 64MB RAM. The necessary circuits for communication with either the DAE3 electronic box as well as the 16-bit AD-converter system for optical detection and digital I/O interface are contained on the DASY4 I/O-board, which is directly connected to the PC/104 bus of the CPU board.

The measurement server performs all real-time data evaluation for field measurements and surface detection, controls robot movements and handles safety operation. The PC-operating system cannot interfere with these time critical processes. All connections are supervised by a watchdog, and disconnection of any of the cables to the measurement server will automatically disarm the robot and disable all program-controlled robot movements. Furthermore, the measurement server is equipped with two expansion slots which are reserved for future applications. Please note that the expansion slots do not have a standardized pinout and therefore only the expansion cards provided by SPEAG can be inserted. Expansion cards from any other supplier could seriously damage the measurement server. Calibration: No calibration required.

5.2 DATA ACQUISITION ELECTRONICS (DAE)

The data acquisition electronics (DAE3) consists of a highly sensitive electrometer grade preamplifier with auto-zeroing, a channel and gain-switching multiplexer, a fast 16 bit AD converter and a command decoder and control logic unit. Transmission to the measurement server is accomplished through an optical downlink for data and status information as well as an optical uplink for commands and the clock. The mechanical probe mounting device includes two different sensor systems for frontal and sideways probe contacts. They are used for mechanical surface detection and probe collision detection. The input impedance of the DAE3 box is 200M Ω ; the inputs are symmetrical and floating. Common mode rejection is above 80 dB.



Figure 3: DAE

5.3 ER3DV6 ISOTROPIC E-FIELD PROBE FOR GENERAL NEAR-FIELD MEASUREMENTS

- Construction:** One dipole parallel, two dipoles normal to probe axis
Built-in shielding against static charges
PEEK enclosure material (resistant to organic solvents, e.g., glycolether)
- Calibration:** In air from 100 MHz to 3.0 GHz (absolute accuracy $\pm 6.0\%$, $k=2$)
- Frequency:** 100 MHz to > 6 GHz; Linearity: ± 0.2 dB (100 MHz to 3 GHz)
- Directivity:** ± 0.2 dB in air (rotation around probe axis)
 ± 0.4 dB in air (rotation normal to probe axis)
- Dynamic Range:** 2 V/m to > 1000 V/m; Linearity: ± 0.2 dB
- Dimensions:** Overall length: 330 mm (Tip: 16 mm)
Tip diameter: 8 mm (Body: 12 mm)
Distance from probe tip to dipole centers: 2.5 mm
The closest part of the sensor element is 1.1 mm closer to the tip
- Application:** General near-field measurements up to 6 GHz
Field component measurements
Fast automatic scanning in phantoms



Figure 4 and 5: ER3DV6 E-Field Probe

5.4 H3DV6 ISOTROPIC E-FIELD PROBE FOR GENERAL NEAR-FIELD MEASUREMENTS

- Construction:** Three concentric loop sensors with 3.8 mm loop diameters resistively loaded detector diodes for linear response
Built-in shielding against static charges
PEEK enclosure material (resistant to organic solvents, e.g., glycoether)
- Frequency:** 200 MHz to 3 GHz (absolute accuracy $\pm 6.0\%$, $k=2$); Output linearized
- Directivity:** ± 0.25 dB (spherical isotropy error)
- Dynamic Range:** 10 mA/m to 2 A/m at 1 GHz
- E-Field Interference:** $< 10\%$ at 3 GHz (for plane wave)
- Dimensions:** Overall length: 330 mm (Tip: 40 mm)
Tip diameter: 6 mm (Body: 12 mm)
Distance from probe tip to dipole centers: 3 mm
The closest part of the sensor element is 1.9 mm closer to the tip
- Application:** General magnetic near-field measurements up to 3 GHz
Field component measurements
Surface current measurements
Measurements in air or liquids
Low interaction with the measured field



Figure 6 and 7: H3DV6 H-Field Probe

5.5 LIGHT BEAM UNIT

The light beam switch allows automatic "tooling" of the probe. During the process, the actual position of the probe tip with respect to the robot arm is measured, as well as the probe length and the horizontal probe offset. The software then corrects all movements, so that the robot coordinates are valid for the probe tip. The repeatability of this process is better than 0.1 mm. If a position has been taught with an aligned probe, the same position will be reached with another aligned probe within 0.1 mm, even if the other probe has different dimensions. During probe rotations, the probe tip will keep its actual position.



Figure 8: Light Beam Unit

5.6 TEST ARCH

- Construction:** Enables easy and well defined positioning of the phone and validation dipoles as well as simple teaching of the robot.
- Dimensions:** 370 x 370 x 370mm

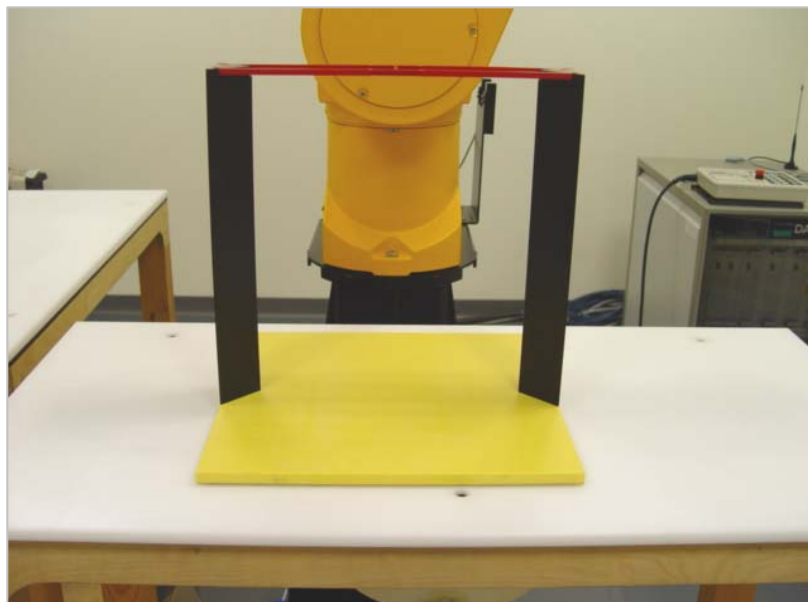

Page 9
Figure 9: Test Arch



5.7 PHONE POSITIONER

Construction: Supports accurate and reliable positioning of any phone effect on near field $<+/- 0.5\text{dB}$

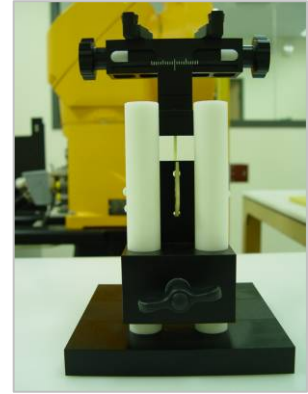

Figure 10: Phone positioner

5.8 SYSTEM VALIDATION KITS

Construction: Symmetrical dipole with built-in two step matching network and balun
CD835V3

Frequency Band: 800 - 960 MHz (free space)

Return Loss: $> 15\text{ dB}$

Calibrated at: 835MHz

Power Capability: 50W continuous

Length & Height: 166 x 330 mm

CD1880V3

Frequency Band: 1710 - 2000 MHz (free space)

Return Loss: $> 18\text{ dB}$

Calibrated at: 1880MHz

Power Capability: 50W continuous

Length & Height: 80.8 x 330 mm

CD2450V3

Frequency Band: 2250 - 2650 MHz (free space)

Return Loss: $> 18\text{ dB}$ over frequency band in free space

Calibrated at: 2450MHz

Power Capability: 50W continuous

Length & Height: 59.9 x 330 mm

Dipole Holder: Tripod holder with adapter

Regular: Hight Range 205 - 300 mm

Shortened: Hight Range 160 - 210 mm

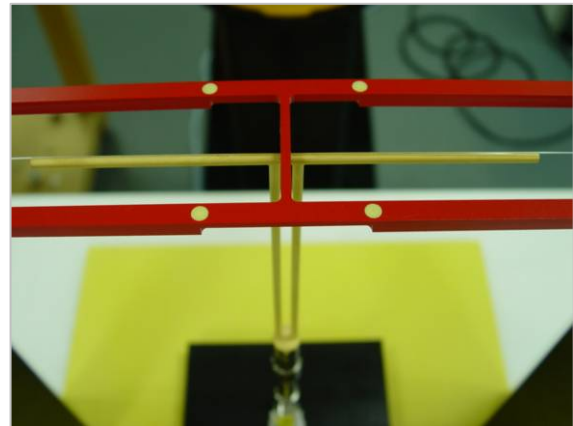

Figure 10: Dipole with Test Arch

5.9 SOFTWARE HAC V4.5

Easy teaching of predefined ANSI C63.19 3.12(January 18, 2006) measurement area
Evaluation incorporates automatic exclusion of high-level areas
Documentation ready for inclusion into compliance report.

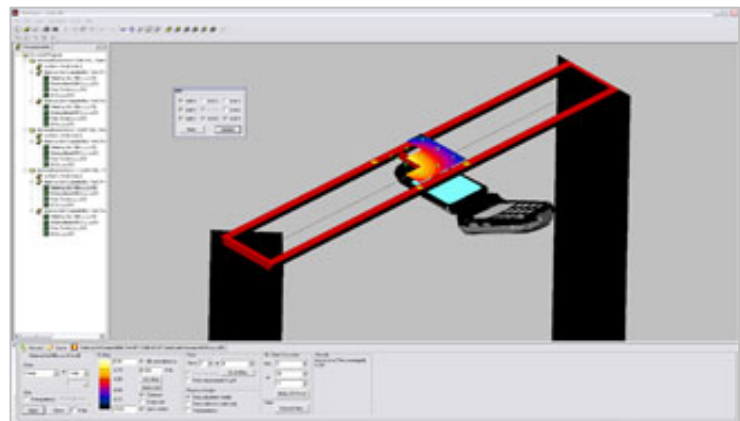

Figure 11: DASY4 software



6. EVALUATION PROCEDURES

The following are step-by-step test procedures.

1. Confirm proper operation of the field probe, probe measurement system and other instrumentation and the positioning system.
2. Position the WD in its intended test position.
3. Configure the WD normal operation for maximum rated RF output power, at the desired channel and other operating parameters, (e.g. test mode) as intended for the test.
4. The center sub-grid shall be centered on the center of the WD output (acoustic or T-coil output), as appropriate. Locate the field probe at the initial test position in the 5 x 5 cm grid, which is contained in the measurement plane, see illustrated in Figure 5.
5. Record the reading.
6. Scan the entire 5 x 5 cm region in equally spaced increments and record the reading at each measurement point. The distance between measurement points shall be sufficient to assure the identification of the peak reading.
7. Identify the five contiguous sub-grids around the center sub-grid with the lowest maximum strength readings. Thus the 6 areas to be used to determine the WD's peak emissions are identified and outlined for the final manual scan. Please note that a maximum of five blocks can be excluded for both E- and H-field measurements for the WD output being measured. State another way, the center sub-grid and 3 other must be common to both the E- and H-field measurements.
8. Identify the highest field reading within the non-excluded sub-grids identified in step 7.
9. Convert the highest field reading within identified in step 8 to peak V/m or A/m, as appropriate.
10. Repeat steps 1-10 for both the E- and H-field measurements.
11. Compare this reading to the categories in ANSI-PC63.19 and record the resulting category. The lowest category number listed in ANSI-PC63.19 obtained in step 10 for either E or H field determines the M category for the audio coupling mode assessment. Record the WD category rating.



7. MEASUREMENT UNCERTAINTY

HAC UNCERTAINTY BUDGET ACCORDING TO ANSI C63.19: 2007							
Error Description	Uncertainty Value	Probability distribution	Divisor	(C _i) E	(C _i) H	Std. Unc. E	Std. Unc. H
Measurement System							
Probe calibration	±5.1%	Normal	1	1	1	±5.1%	±5.1%
Axial isotropy	±4.7%	Rectangular	√3	1	1	±2.7%	±2.7%
Sensor Displacement	±16.5%	Rectangular	√3	1	0.145	±9.5%	±1.4%
Boundary Effects	±2.4%	Rectangular	√3	1	1	±1.4%	±1.4%
Linearity	±4.7%	Rectangular	√3	1	1	±2.7%	±2.7%
Scaling to Peak Envelope Power	±2.0%	Rectangular	√3	1	1	±1.2%	±1.2%
System Detection Limit	±1.0%	Rectangular	√3	1	1	±0.6%	±0.6%
Readout Electronics	±0.3%	Rectangular	√3	1	1	±0.3%	±0.3%
Response Time	±0.8%	Rectangular	√3	1	1	±0.5%	±0.5%
Integration Time	±2.6%	Rectangular	√3	1	1	±1.5%	±1.5%
RF Ambient Condition	±3.0%	Rectangular	√3	1	1	±1.7%	±1.7%
RF Reflections	±12.0%	Rectangular	√3	1	1	±6.9%	±6.9%
Probe Positioner	±1.2%	Rectangular	√3	1	0.67	±0.7%	±0.5%
Probe Positioning	±4.7%	Rectangular	√3	1	0.67	±2.7%	±1.8%
Extrap. And Interpolation	±1.0%	Rectangular	√3	1	1	±0.6%	±0.6%
Test Sample Related							
Device Positioning Vertical	±4.7%	Rectangular	√3	1	0.67	±2.7%	±1.8%
Device Positioning Lateral	±1.0%	Rectangular	√3	1	1	±0.6%	±0.6%
Device Holder and Phantom	±2.4%	Rectangular	√3	1	1	±1.4%	±1.4%
Power Drift	±5.0%	Rectangular	√3	1	1	±2.9%	±2.9%
Phantom and Setup Related							
Phantom Thickness	±2.4%	Rectangular	√3	1	0.67	±1.4%	±0.9%
Combined Std. Uncertainty						±14.7%	±10.9%
Expanded Std. Uncertainty on Power						±29.4%	±21.8%
Expanded Std. Uncertainty on Field						±14.7%	±10.9%

Table: Worst-case uncertainty budget for HAC free field assessment according to ANSI C63.19 D3.12(January 18, 2006) [1]. The budget is valid for the frequency range 800 MHz – 3GHz and represents a worst-case analysis. For specific tests and configurations, the uncertainty could be considerably smaller.



8. TEST PROCEDURES

The following are RF emission step-by-step test procedures:

Test Instructions

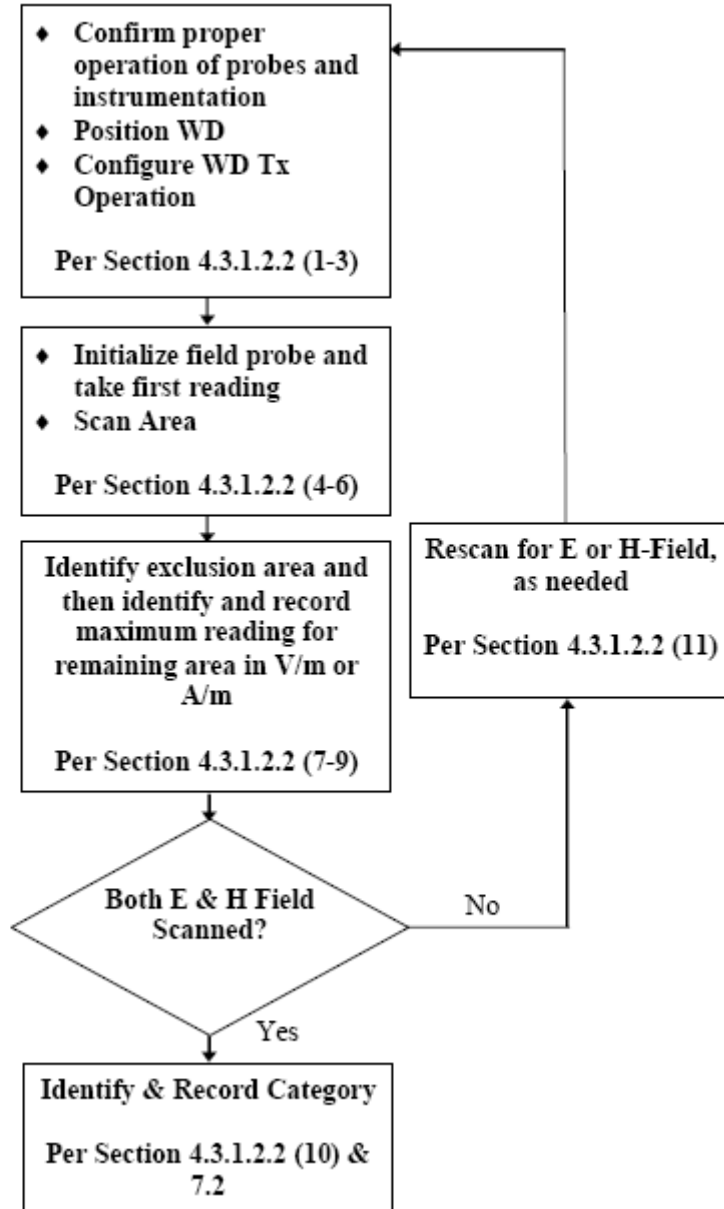

Figure 12: Near-field emission automated test flowchart

RF EMISSION TEST SETUP:

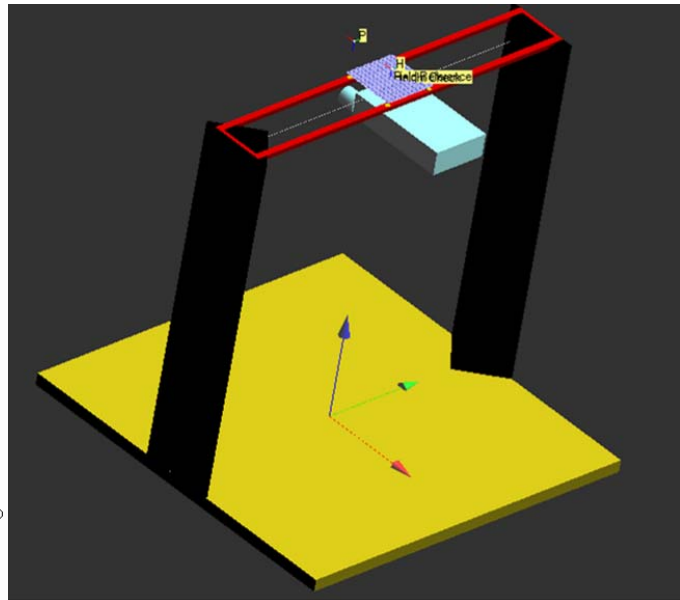
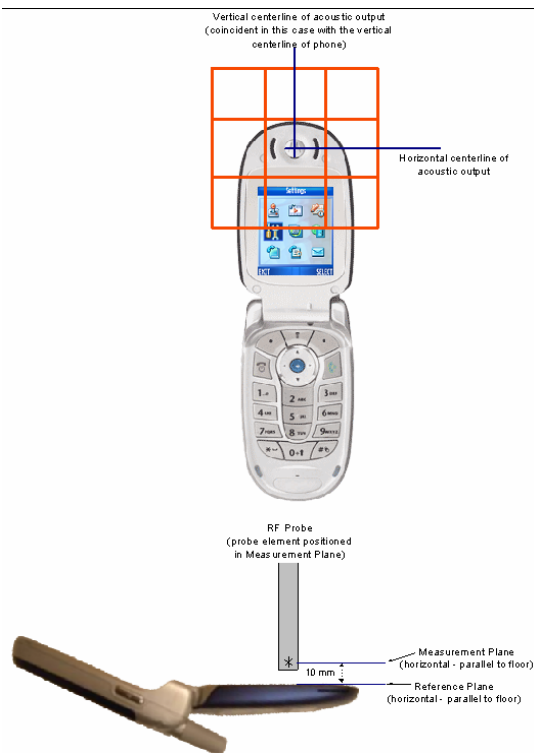

Figure 13: WD near-field emission test setup

Figure 14: HAC test arch with WD setup

The following are measurement RF near field emission:

1. Confirm proper operation of the field probe, probe measurement system and other instrumentation and the positioning system.
2. Position the WD in its intended test position. The WD's acoustic output point perpendicular to the field probe with test arch (see the figure 13 and figure 14).
3. Configure the WD normal operation for maximum rated RF output power, at the desired channel and other operating parameters, (e.g. test mode) as intended for the test. The fully charge battery was used for each test.
4. The center sub-grid was centered on the center of the WD output (acoustic or T-Coil output), as appropriate. The field probe at the initial test position in the 5 x 5 cm grid with a 5mm step size.
5. The field probe was aligned in the light beam. The phantom adjustment and verification procedure (1. surface check; 2. Verify Height 0.5mm above Center; 3. Verify Height 0.5mm above Center; 4 Verify Height for Scan) was performed before each setup change.
6. The measurement system was tested 5 x 5 cm grid with a 5mm step size. The probe was rotated 360° about the azimuth axis at the maximum interpolated position. The reading was recorded at each measurement procedure.
7. The power drift was measurement for each test. Power drift shall be below 5% or 0.25dB.If the power drift was higher than 5% or 0.25dB, the measurement was re-test.
8. Around the center sub-grid, five contiguous sub-grids around the center sub-grid with lowest maximum field strength reading. A maximum of five blocks can be excluded for both E- and H-field measurements for the WD output was measured.
9. The highest field strength reading was converted to peak V/m or A/m, as appropriate. This conversion was done using the appropriate probe modulation factor.
10. Repeat steps 1-9 for both the E- and H-field measurements.
11. The peak reading was according to the categories define in the C63.19 D3.12(January 18, 2006) using the appropriate AWF.
12. The DASY4 software will control the DASY4 system to carried out the follow procedure for each mode testing.



9. PERFORMANCE

9.1 ARTICULATION WEIGHTING FACTOR (AWF)

The following AWF factors shall be used for the standard transmission protocols:

Standard	Technology	AWF (dB)
TIA/EIA/IS-2000	CDMA	0
TIA/EIA-136	TDMA (50 Hz)	0
J-STD-007	GSM (217)	-5
T1/T1P1/3GPP	UMTS (WCDMA)	0
iDENTM	TDMA (22 and 11 Hz)	0

Table 8.1 Articulation Weighting Factor (AWF)

9.2 TELEPHONE N-FILED CATEGORY

The following shows the M-rating for wireless telephone:

Category		Telephone RF parameters < 960 MHz			
Near field	AWF	E-field emissions		H-field emissions	
Category M1/T1	0	631.0 to 1122.0	V/m	1.91 to 3.39	A/m
	-5	473.2 to 841.4	V/m	1.43 to 2.54	A/m
Category M2/T2	0	354.8 to 631.0	V/m	1.07 to 1.91	A/m
	-5	266.1 to 473.2	V/m	0.80 to 1.43	A/m
Category M3/T3	0	199.5 to 354.8	V/m	0.60 to 1.07	A/m
	-5	149.6 to 266.1	V/m	0.45 to 0.80	A/m
Category M4/T4	0	< 199.5	V/m	< 0.60	A/m
	-5	< 149.6	V/m	< 0.45	A/m

Category		Telephone RF parameters > 960 MHz			
Near field	AWF	E-field emissions		H-field emissions	
Category M1/T1	0	199.5 to 354.8	V/m	0.60 to 1.07	A/m
	-5	149.6 to 266.1	V/m	0.45 to 0.80	A/m
Category M2/T2	0	112.2 to 199.5	V/m	0.34 to 0.60	A/m
	-5	84.1 to 149.6	V/m	0.25 to 0.45	A/m
Category M3/T3	0	63.1 to 112.2	V/m	0.19 to 0.34	A/m
	-5	47.3 to 84.1	V/m	0.14 to 0.25	A/m
Category M4/T4	0	< 63.1	V/m	< 0.19	A/m
	-5	< 47.3	V/m	< 0.14	A/m

Table 8.2 Telephone near-field categories in linear units

NOTE
The WD must be performed in the category M3

10. MEASUREMENT RESULTS

10.1 SYSTEM CHECK

The test setup should be validated when first configured and verified periodically thereafter to ensure proper function. The procedure consists of two parts: dipole validation and determination of probe modulation factor.

10.2 DIPOLE VALIDATION

The HAC validation dipole antenna serves as a known source for an electrical and magnetic RF output. Figure 2 shows the setup used for the dipole validation.

1. The dipole antenna was placed in the position normally occupied by the WD.
2. The dipole was energized with a 20 dBm un-modulated continuous-wave signal.
3. The length of the dipole was scanned with both E-field and H-field probes and the maximum value for each scan was recorded.
4. The readings were compared with the values provided by the probe manufacturer and were found to agree within the allowed tolerance of 10%. Figure 2: Dipole Validation Procedure

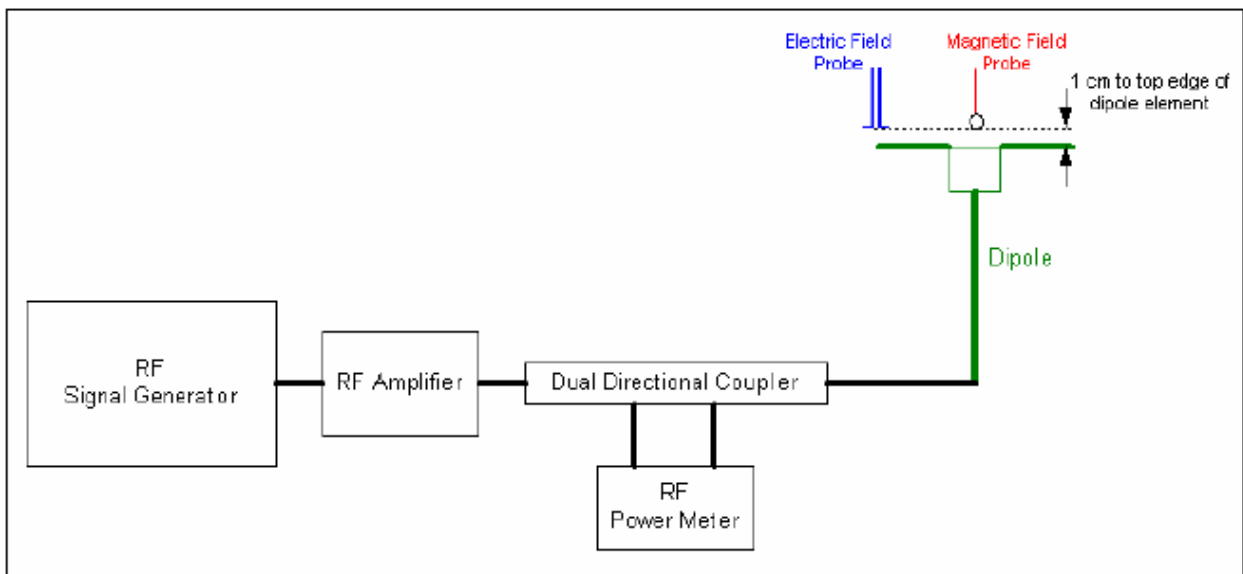

Figure 15: WD dipole calibration procedure

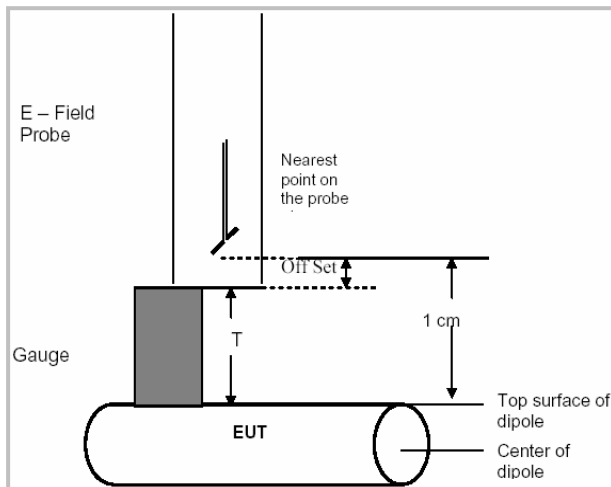

Figure 16

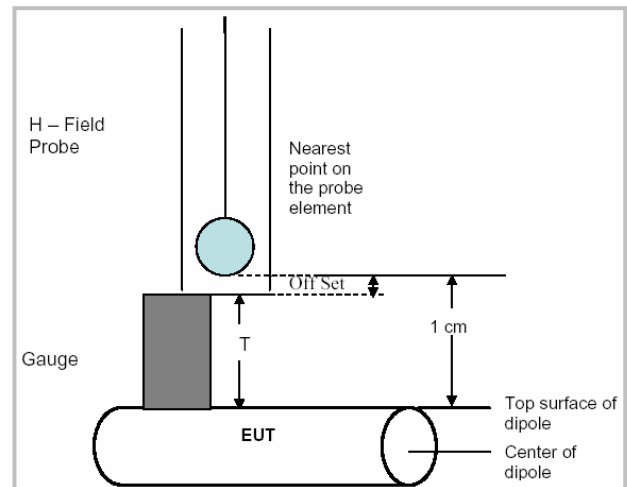

Figure 17

The probe is positioned over the illuminated dipole at 10 mm distance from the nearest point on the probe sensor element to the top surface (edge) of the dipole element.



10.3 PROBE MODULATION FACTOR

Purpose

The HAC Standard requires measurement of the peak envelope E- and H-fields of the wireless device (WD). Para. 4.1.2.1, and C.3.1 of the standard describes the Probe Modulation Response Factor that shall be applied to convert the probe reading to Peak Envelope Field.

Definitions

The Probe Modulation Factor (PMF) is defined as the ratio of the field readings for a CW and a modulated signal with the equivalent Field Envelope Peak as defined in the Standard (Chapter C.3.1).

Evaluation Procedure for Unknown PMF (DASY4 Application note, Section 28.8)

The proposed measurement setup corresponds to the procedure as required in the Standard, Chapter C.3.1.

1. Install a calibration dipole for the appropriate frequency band under the Test Arch Phantom and select the proper phantom section according to the probe type installed (E- or H-field). Move the probe to the field reference point. (Do not move the probe between the subsequent CW and modulated measurements.)
2. Install the field probe in the setup.
3. The modulated signal to the dipole must be monitored to record peak amplitude and compared to a CW signal with the same peak envelope level (e.g., with a directional coupler and a spectrum analyzer in zero span mode set to the operating frequency). To determine the peak envelope level of the modulated signal properly, the settings of a spectrum analyzer shall be as follows:
 - Resolution bandwidth \geq emission bandwidth
 - Video bandwidth \geq 20kHz
 - Center Frequency: nominal center frequency of channel
 - Detection: RMS detection with averaging turned on
 - Trigger: Video or IF trigger, adjusted to give a stable display of the transmission
 - Sweep rate: Sufficiently rapid to permit the transmit pulse to be resolved accurately. The sweep shall be long enough to show a complete transmission. The sweep time may be set to allow a full transmission cycle, displaying the on and off time.
4. Define a DASY4 document and set the procedure properties (frequency, modulation frequency and crest factor) according to the measured signal. Define a multimeter job for the field reading.
5. Define a second procedure for the evaluation of the CW signal (frequency set as above, modulation frequency = 0, crest factor = 1) and a multimeter job.

PMF Measurement Setup Diagram

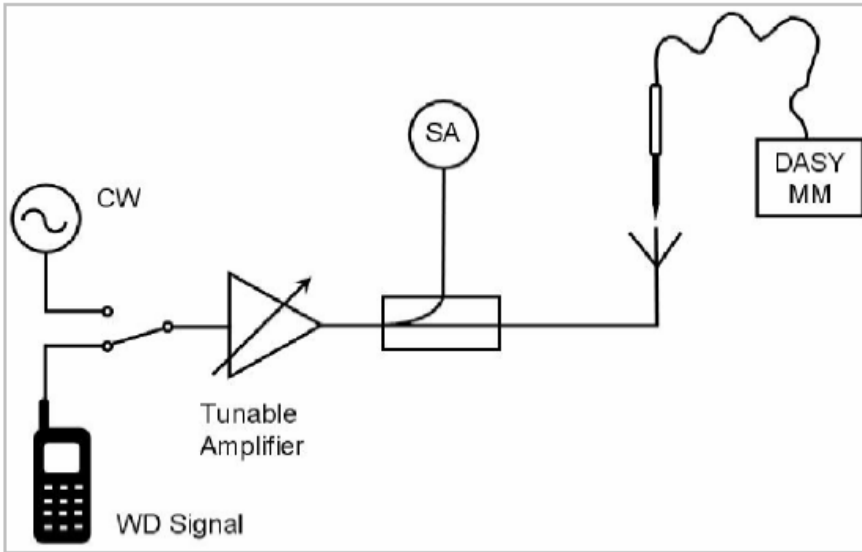

10.4 VALIDATION

f(MHz)	Signal Type	Pulse Average Power (dBm)	Measurement E-field (V/m)	Target E-Field (V/m)	Deviation %
835.00	CW	20.00	164.60	171.00	-3.74
835.00	AM80%	20.00	98.10	—	—
835.00	GSM	20.00	64.30	—	—
835.00	WCDMA	20.00	145.30	—	—
1880.00	CW	20.00	134.60	139.90	-3.79
1880.00	AM80%	20.00	84.20	—	—
1880.00	GSM	20.00	54.10	—	—
1880.00	WCDMA	20.00	127.30	—	—
f(MHz)	Signal Type	Pulse Average Power (dBm)	Measurement H-field (A/m)	Target H-Field (A/m)	Deviation %
835.00	CW	20.00	0.463	0.471	-1.70
835.00	AM80%	20.00	0.288	—	—
835.00	GSM	20.00	0.173	—	—
835.00	WCDMA	20.00	0.447	—	—
1880.00	CW	20.00	0.468	0.467	0.21
1880.00	AM80%	20.00	0.318	—	—
1880.00	GSM	20.00	0.202	—	—
1880.00	WCDMA	20.00	0.452	—	—

**10.5 MODULATION FACTOR**

f(MHz)	Signal Type	Pulse Average Power (dBm)	Measurement E-field (V/m)	Target E-Field (V/m)	Deviation %	Mod. Factor Ration
835.00	CW	20.00	164.60	171.00	-3.74	–
835.00	AM80%	20.00	98.10	–	–	1.68
835.00	GSM	20.00	64.30	–	–	2.56
835.00	WCDMA	20.00	145.30	–	–	1.13
1880.00	CW	20.00	134.60	138.20	-2.60	–
1880.00	AM80%	20.00	84.20	–	–	1.60
1880.00	GSM	20.00	54.10	–	–	2.49
1880.00	WCDMA	20.00	127.30	–	–	1.06

f(MHz)	Signal Type	Pulse Average Power (dBm)	Measurement H-field (A/m)	Target H-Field (A/m)	Deviation %	Mod. Factor Ration
835.00	CW	20.00	0.463	0.471	-1.70	–
835.00	AM80%	20.00	0.288	–	–	1.61
835.00	GSM	20.00	0.173	–	–	2.68
835.00	WCDMA	20.00	0.447	–	–	1.04
1880.00	CW	20.00	0.468	0.467	0.21	–
1880.00	AM80%	20.00	0.318	–	–	1.47
1880.00	GSM	20.00	0.202	–	–	2.32
1880.00	WCDMA	20.00	0.452	–	–	1.04

Note:

1. Modulation Factor = Measured E/H Field (CW) / Measured E/H Field (Modulation)
2. The HAC measurement of peak V/m or A/m should be calculation by formula or insert crest factor in the day4 software.
3. Peak(dB V/m or dB A/m) = 20 x log(Reading [time averaging V/m or A/m] x Probe Modulation Factor)



10.6 EUT TUNE-UP PROCEDURES

The following procedures had been used to prepare the EUT for the SAR test.

- To setup the desire channel frequency and the maximum output power. A Radio Communication Tester “Agilent E5515c 8960 ” was used to program the EUT.
- If the SAR measured on the highest output channel is < 50% of the SAR limit, SAR evaluation for the other required channels is unnecessary.

GSM 850 / GPRS 850

Network Support: *GSM / GPRS*

Main Service: *Circuit Switched / Package Switched*

Power Setting: *33dBm / 33dBm class 10(2Up3Dn)*

GPRS support class B

GSM 1900 / GPRS 1900

Network Support: *GSM only / GPRS*

Main Service: *Circuit Switched / Package Switched*

Power Setting: *30dBm / 30dBm class 10(2Up3Dn)*

GPRS support class B



10.7 OUTPUT POWER FOR AVERAGE

This procedure assume the Agilent E5515C 8960 Test Set the following applications installed and with valid license.

Conducted output power (Average)(dBm)

GSM		GSM mode	GPRS mode	EDGE mode
		Average Power	Average Power	Average Power
GSM 850	Ch 128	32.71	23.89	20.89
	Ch 190	32.82	24.10	20.78
	Ch 251	32.72	23.98	20.58
GSM		GSM mode	GPRS mode	EDGE mode
		Average Power	Average Power	Average Power
GSM 1900	Ch 512	28.80	20.10	18.79
	Ch 661	28.42	19.58	18.68
	Ch 810	28.40	19.58	18.38
WCDMA		WCDMA	HSDPA	HSUPA
		Average Power	Average Power	Average Power
Band II	Ch 9262	23.33	23.46	23.14
	Ch 9400	23.18	23.48	22.84
	Ch 9538	23.63	23.56	23.03
WCDMA		WCDMA	HSDPA	HSUPA
		Average Power	Average Power	Average Power
Band V	Ch 4132	23.71	23.24	23.15
	Ch 4182	23.66	23.26	23.33
	Ch 4233	23.50	23.32	23.40
WCDMA		WCDMA	HSDPA	HSUPA
		Average Power	Average Power	Average Power
Band IV	Ch 1312	24.16	23.73	23.61
	Ch 1412	24.25	23.84	23.68
	Ch 1513	24.34	23.68	23.54

10.8 HAC MEASUREMENT RESULTS

1. E-Field Emission for GSM/WCDMA:



Operation mode	Channel	f(MHz)	PMF	Peak(E-field) V/m	M-Rating
GSM850	128	824.2	2.53	98.6	M4
	190	836.6	2.54	119.6	M4
	251	848.8	2.54	130.5	M4
Operation mode	Channel	f(MHz)	PMF	Peak(E-field) V/m	M-Rating
GSM1900	512	1850.2	2.53	14.5	M4
	661	1880.0	2.53	13.2	M4
	810	1909.8	2.53	18.6	M4
Operation mode	Channel	f(MHz)	PMF	Peak(E-field) V/m	M-Rating
WCDMA Band II	9262	1852.4	0.90	8.80	M4
	9400	1880.0	0.90	7.36	M4
	9538	1907.6	0.90	7.67	M4
Operation mode	Channel	f(MHz)	PMF	Peak(E-field) V/m	M-Rating
WCDMA Band IV	1312	1712.4	0.9	10.8	M4
	1413	1732.6	0.9	10.5	M4
	1513	1752.6	0.9	11.4	M4
Operation mode	Channel	f(MHz)	PMF	Peak(E-field) V/m	M-Rating
WCDMA Band V	4132	826.4	1.07	43.5	M4
	4182	836.4	1.07	43.1	M4
	4233	846.6	1.07	48.9	M4

Note1: BT/WLAN is not activated during test because it is not held-to-ear service.

2. H-Field Emissions for GSM/WCDMA:



Operation mode	Channel	f(MHz)	PMF	Peak(H-field) V/m	M-Rating
GSM850	128	824.2	1.81	0.121	M4
	190	836.6	1.81	0.134	M4
	251	848.8	1.81	0.152	M4
Operation mode	Channel	f(MHz)	PMF	Peak(H-field) V/m	M-Rating
GSM1900	512	1850.2	2.63	0.065	M4
	661	1880.0	2.63	0.051	M4
	810	1909.8	2.63	0.057	M4
Operation mode	Channel	f(MHz)	PMF	Peak(H-field) V/m	M-Rating
WCDMA Band II	9262	1852.4	0.81	0.023	M4
	9400	1880.0	0.81	0.020	M4
	9538	1907.6	0.81	0.023	M4
Operation mode	Channel	f(MHz)	PMF	Peak(H-field) V/m	M-Rating
WCDMA Band IV	1312	1712.4	0.81	0.024	M4
	1413	1732.6	0.81	0.027	M4
	1513	1752.6	0.81	0.027	M4
Operation mode	Channel	f(MHz)	PMF	Peak(H-field) V/m	M-Rating
WCDMA Band V	4132	826.4	0.86	0.062	M4
	4182	836.4	0.86	0.061	M4
	4233	846.6	0.86	0.068	M4

Note1: BT/WLAN is not activated during test because it is not held-to-ear service.

11. EUT PHOTO

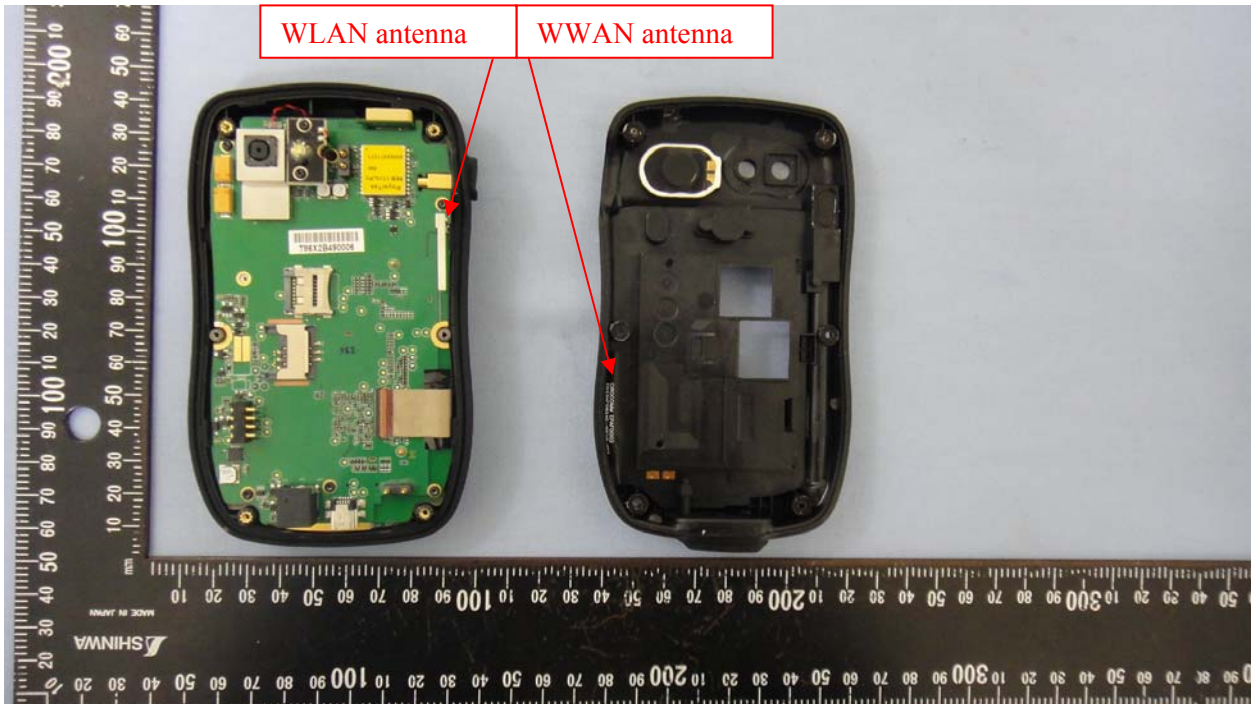



12. EQUIPMENT LIST & CALIBRATION STATUS

Name of Equipment	Manufacturer	Type/Model	Serial Number	Calibration Cycle(days)	Calibration Due
S-Parameter Network Analyzer	Agilent	E8358A	US40260243	365	07/04/2012
Electronic Probe kit	Hewlett Packard	85070D	N/A	N/A	N/A
Power Meter	Anritsu	ML2495A	1012009	365	03/27/2012
Power Sensor	Anritsu	MA2411B	0917072	365	03/08/2012
Spectrum Analyzer	Agilent	E4446A	US42510252	365	11/04/2012
Wireless Communication Test Set	Agilent	E5515C 8960	MY48363204	365	09/13/2012
Signal Generator	Agilent	83630B	3844A01022	365	07/11/2012
Data Acquisition Electronics (DAE)	SPEAG	DAE4	877	365	02/17/2012
HAC Test Arch	SPEAG	SD HAC P01 BA	1027	N/A	N/A
Devices Holder	SPEAG	N/A	N/A	N/A	N/A
835 MHz System Validation Dipole	SPEAG	CD835V3	1149	365	12/05/2012
1880 MHz System Validation Dipole	SPEAG	CD1880V3	1135	365	12/05/2012
Probe Alignment Unit	SPEAG	LB (V2)	348	N/A	N/A
Robot	Staubli	TX60L	F08/5A6GA1/A01	N/A	N/A
Devices Holder	SPEAG	N/A	N/A	N/A	N/A
E-Field Probe	SPEAG	ER3DV6	2345	365	04/14/2012
H-Field Probe	SPEAG	H3DV6	6163	365	04/17/2012



13. LOCATION OF TEST SITE

All measurement facilities used to collect the measurement data are located at

- No. 81-1, Lane 210, Bade Rd. 2, Luchu Hsiang, Taoyuan Hsien, Taiwan, R.O.C.
- No.11, Wu-Gong 6th Rd., Wugu Industrial Park, New Taipei City 248, Taiwan (R.O.C.)
- No. 199, Chunghsen Road, Hsintien City, Taipei Hsien, Taiwan, R.O.C.

14. ATTACHMENTS

No.	Contents
1	System Validation Plots
2	HAC Test Plots
3	Certificate of E-filed Probe ER3DV6 SN:2345
4	Certificate of H-filed Probe H3DV6 SN:6163
5	Certificate of System Validation Dipole CD835V3 SN:1149
6	Certificate of System Validation Dipole CD1880V3 SN:1135

END OF REPORT