



FCC Test Report

EQUIPMENT : PDA
BRAND NAME : Trimble
MODEL NAME : Juno SC
FCC ID : JUP66400
STANDARD : FCC 47 CFR FCC Part 15 Subpart B
CLASSIFICATION : Certification
APPLICANT : Trimble Navigation Ltd.

935 Stewart Drive, Sunnyvale CA 94088-3642, U.S.A.

The product sample received on Oct. 04, 2008 and completely tested on Oct. 13, 2008. We, SPORTON INTERNATIONAL INC., would like to declare that the tested sample has been evaluated in accordance with the procedures given in ANSI C63.4-2003 and shown the compliance with the applicable technical standards.

The test results in this report apply exclusively to the tested model / sample. Without written approval of SPORTON INTERNATIONAL INC., the test report shall not be reproduced except in full.

Reviewed by: Roy Wu / Manager



Lab Code: 200079-0

SPORTON INTERNATIONAL INC.

No. 52, Hwa Ya 1st Rd., Hwa Ya Technology Park, Kwei-Shan Hsiang, Tao Yuan Hsien, Taiwan, R.O.C.



TABLE OF CONTENTS

SUMMARY OF TEST RESULT 3

REVISION HISTORY..... 4

1. GENERAL DESCRIPTION 5

 1.1 Applicant..... 5

 1.2 Manufacturer 5

 1.3 Feature of Equipment Under Test..... 5

 1.4 Test Site 6

 1.5 Applied Standards 6

 1.6 Ancillary Equipment List..... 7

2. TEST CONFIGURATION OF EQUIPMENT UNDER TEST 8

 2.1 Test Mode 8

 2.2 Connection Diagram of Test System 9

 2.3 Test Software 10

3. TEST RESULT 11

 3.1 Test of AC Conducted Emission Measurement 11

 3.2 Test of Radiated Emission Measurement 15

4. LIST OF MEASURING EQUIPMENTS..... 21

5. UNCERTAINTY OF EVALUATION 22

6. CERTIFICATION OF NVLAP ACCREDITATION 24

APPENDIX A. PHOTOGRAPHS OF EUT

APPENDIX B. SETUP PHOTOGRAPHS



SUMMARY OF TEST RESULT

Report Section	FCC Rule	IC Rule	Description	Limit	Result	Remark
3.1	15.107	7.2.2	AC Conducted Emission	< 15.107 limits < RSS-Gen table 2 limits	PASS	Under limit 10.8 dB at 2.414 MHz
3.2	15.109	7.2.3.2	Radiated Emission	< 15.109 limits or < RSS-Gen table 1 limits (Section 6)	PASS	Under limit 10.91 dB at 255.18 MHz



Revision History

REPORT NO.	VERSION	DESCRIPTION	ISSUED DATE
FC8O0405	Rev. 02	Initial issue of report	Nov. 11, 2008



1. General Description

1.1 Applicant

Trimble Navigation Ltd.
935 Stewart Drive, Sunnyvale CA 94088-3642, U.S.A.

1.2 Manufacturer

GOLDTEK Technology Co., Ltd.
3F., No.3, Ln. 768, Sec. 4, Pateh Rd., Taipei 115, Taiwan, R.O.C.

1.3 Feature of Equipment Under Test

Product Feature & Specification	
Equipment	PDA
Brand Name	Trimble
Model Name	Juno SC
Tx Frequency Range	GSM850 : 824 MHz ~ 849 MHz GSM1900 : 1850 MHz ~1910 MHz WCDMA Band V : 824 MHz ~ 849 MHz WCDMA Band II : 1850 MHz ~ 1910 MHz Bluetooth : 2400 MHz ~ 2483.5 MHz WLAN : 2400 MHz ~ 2483.5 MHz
Rx Frequency Range	GSM850 : 869 MHz ~ 894 MHz GSM1900 : 1930 MHz ~ 1990 MHz WCDMA Band V : 869 MHz ~ 894 MHz WCDMA Band II : 1930 MHz ~ 1990 MHz Bluetooth : 2400 MHz ~ 2483.5 MHz WLAN : 2400 MHz ~ 2483.5 MHz
Antenna Type	PIFA Antenna
HW Version	1.0
SW Version	1.0
Type of Modulation	GSM / GPRS : GMSK EDGE : 8PSK WCDMA : QPSK HSDPA : QPSK / 16QAM Bluetooth (1Mbps) : GFSK Bluetooth EDR (2Mbps) : π /4-DQPSK Bluetooth EDR (3Mbps) : 8-DPSK WLAN : DSSS / OFDM
EUT Stage	Identical Prototype

Accessories List:

Accessories Specification		
AC Adapter	Brand Name	Trimble
	Model Name	3A-161WP05
	Power Rating	I/P: 100-240Vac, 50-60Hz, 0.6A; O/P: 5Vdc, 2.6A
	AC Power Cord Type	1.24 meter non-shielded cable with ferrite core
Battery	Model Name	BA-1405206
	Power Rating	3.7Vdc, 2600mAh
	Type	Li-ion
USB Cable	Signal Line Type	1.2 meter shielded cable with ferrite core
LCD Panel	Brand Name	Topyy
	Model Name	td035sted7

Remark:

1. The above EUT's information was declared by manufacturer. Please refer to the specifications or user's manual for more detailed description.
2. For accessories equipped with this EUT, please refer to the appendix of the external photo.

1.4 Test Site

Test Site	SPORTON INTERNATIONAL INC.		
Test Site Location	No. 52, Hwa Ya 1 st Rd., Hwa Ya Technology Park, Kwei-Shan Hsiang, Tao Yuan Hsien, Taiwan, R.O.C TEL: +886-3-327-3456 FAX: +886-3-328-4978		
Test Site No.	Sporton Site No.		FCC/IC Registration No.
	CO05-HY	03CH06-HY	TW1022/4086B-1

1.5 Applied Standards

According to the specifications of the manufacturer, the EUT must comply with the requirements of the following standards:

- FCC 47 CFR FCC Part 15 Subpart B
- ANSI C63.4-2003
- RSS-Gen Issue 2

Remark: All test items were verified and recorded according to the standards and without any deviation during the test.



1.6 Ancillary Equipment List

Item	Equipment	Trade Name	Model Name	FCC ID	Data Cable	Power Cord
1.	GSM Base Station	R&S	CMU 200	N/A	N/A	Unshielded, 1.8 m
2.	GPS Station	T&E	GS-50	N/A	N/A	Unshielded, 1.8 m
3.	WLAN AP	SMC	SMC-100	HEDWG4005ACC	N/A	Unshielded, 1.8 m
4.	Notebook	DELL	VOSTRO1510	FCC DoC	N/A	AC I/P: Unshielded, 1.2 m DC O/P: Shielded, 1.8 m
5.	Notebook	DELL	PP23LA	QDS-BRCM1020	N/A	AC I/P: Unshielded, 1.2 m DC O/P: Shielded, 1.8 m
6.	Earphone + Mic	Sampo	EK-Y652CS	FCC DoC	Shielded, 1.8m	N/A
7.	Bluetooth Earphone	Samsung	WEP410	A3LWEP410	N/A	N/A
8.	Bluetooth Earphone	Cellink	BTHS-6025-F	PQY-4710874200357	N/A	N/A
9.	i-pod	Apple	A1199	FCC DoC	Shielded, 1.0 m	N/A

2. Test Configuration of Equipment Under Test

2.1 Test Mode

The EUT has been associated with peripherals pursuant to ANSI C63.4-2003 and configuration operated in a manner tended to maximize its emission characteristics in a typical application.

Frequency range investigated: conduction (150 kHz to 30 MHz), radiation (30MHz to the 5th harmonic of the highest fundamental frequency or to 40 GHz, whichever is lower).

Pre-scanned tests were conducted to determine the final configuration from all possible combinations.

The following tables are showing the test modes as the worst cases and recorded in this report.

EUT Configure Mode	Mode Description	Test Condition		
		EMI AC	EMI RE<1G	EMI RE≥1G
1	Charging Mode (EUT with Adapter)	✓	✓	✓

Abbreviations:

EMI AC: AC conducted emissions ; EMI RE ≥ 1G: EUT radiated emissions ≥ 1GHz;

EMI RE < 1G: EUT radiated emissions < 1GHz ;

Note 1: Testing for this mode is not required.

Test Items	EUT Configure Mode	Function Type
AC Conducted Emission	1	Mode 1 : GSM850 Idle + GPS Rx + BT Idle + WLAN Idle + Earphone + USB Link + Camera + Adapter Mode 2 : GSM1900 Idle + GPS Rx + BT Idle + WLAN Idle + Earphone + USB Link + Camera + Adapter Mode 3 : WCDMA Idle + GPS Rx + BT Idle + WLAN Idle + Earphone + USB Link + Camera + Adapter
Radiated Emissions < 1GHz	1	Mode 1 : GSM850 Idle + GPS Rx + BT Idle + WLAN Idle + Earphone + USB Link + Camera + Adapter Mode 2 : GSM1900 Idle + GPS Rx + BT Idle + WLAN Idle + Earphone + USB Link + Camera + Adapter Mode 3 : WCDMA Idle + GPS Rx + BT Idle + WLAN Idle + Earphone + USB Link + Camera + Adapter
Radiated Emissions ≥ 1GHz	1	Mode 1 : WCDMA Idle + GPS Rx + BT Idle + WLAN Idle + Earphone + USB Link + Camera + Adapter

Remark: The Boldface cases were the worst cases of the testing; only the worst data were reported.

2.2 Connection Diagram of Test System

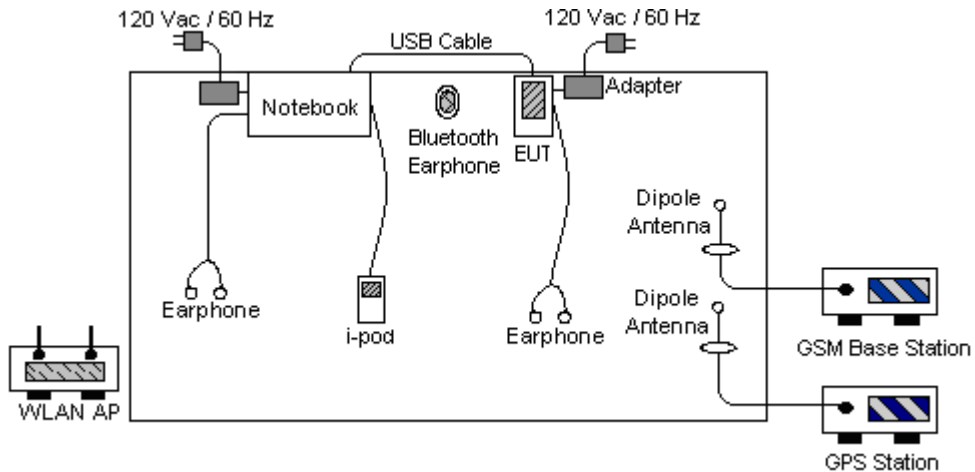



2.3 Test Software

For associated equipment, the executive program, "EMCTEST.EXE" and "EMI.EXE" on notebook WINXP can generate a complete line of continuously repeating "H" pattern.

The programs were executed as follows:

- a. Turn on the power of all equipment.
- b. The notebook reads the test program from the hard disk drive and runs it.
- c. The notebook sends "H" messages to the panel, and the panel displays "H" patterns on the screen.
- d. The notebook sends "H" messages to the internal hard disk, and the hard disk reads and writes the message.
- e. Repeat the steps from b to d.

In GSM or WCDMA idle mode, the EUT is synchronized to the BCCH, and is in continuous receiving mode by setting system simulator's paging reorganization.

At the same time, the EUT was linked with Bluetooth earphone and WLAN AP. For GPS function, the executive program make EUT receive signal from GPS station.

3. Test Result

3.1 Test of AC Conducted Emission Measurement

3.1.1 Limits of AC Conducted Emission

For equipment that is designed to be connected to the public utility (AC) power line, the radio frequency voltage that is conducted back onto the AC power line on any frequency or frequencies within the band 150 kHz to 30 MHz shall not exceed the limits in the following table.

Frequency of emission (MHz)	Conducted limit (dBuV)	
	Quasi-peak	Average
0.15-0.5	66 to 56*	56 to 46*
0.5-5	56	46
5-30	60	50

*Decreases with the logarithm of the frequency.

3.1.2 Measuring Instruments

See list of measuring instruments of this test report.

3.1.3 Test Procedure

1. The EUT was placed 0.4 meter from the conducting wall of the shielding room was kept at least 80 centimeters from any other grounded conducting surface.
2. Connect EUT to the power mains through a line impedance stabilization network (LISN).
3. All the support units are connecting to the other LISN.
4. The LISN provides 50 ohm coupling impedance for the measuring instrument.
5. The FCC states that a 50 ohm, 50 microhenry LISN should be used.
6. Both sides of AC line were checked for maximum conducted interference.
7. The frequency range from 150 kHz to 30 MHz was searched.
8. Set the test-receiver system to Peak Detect Function and specified bandwidth with Maximum Hold Mode.

3.1.4 Test Setup

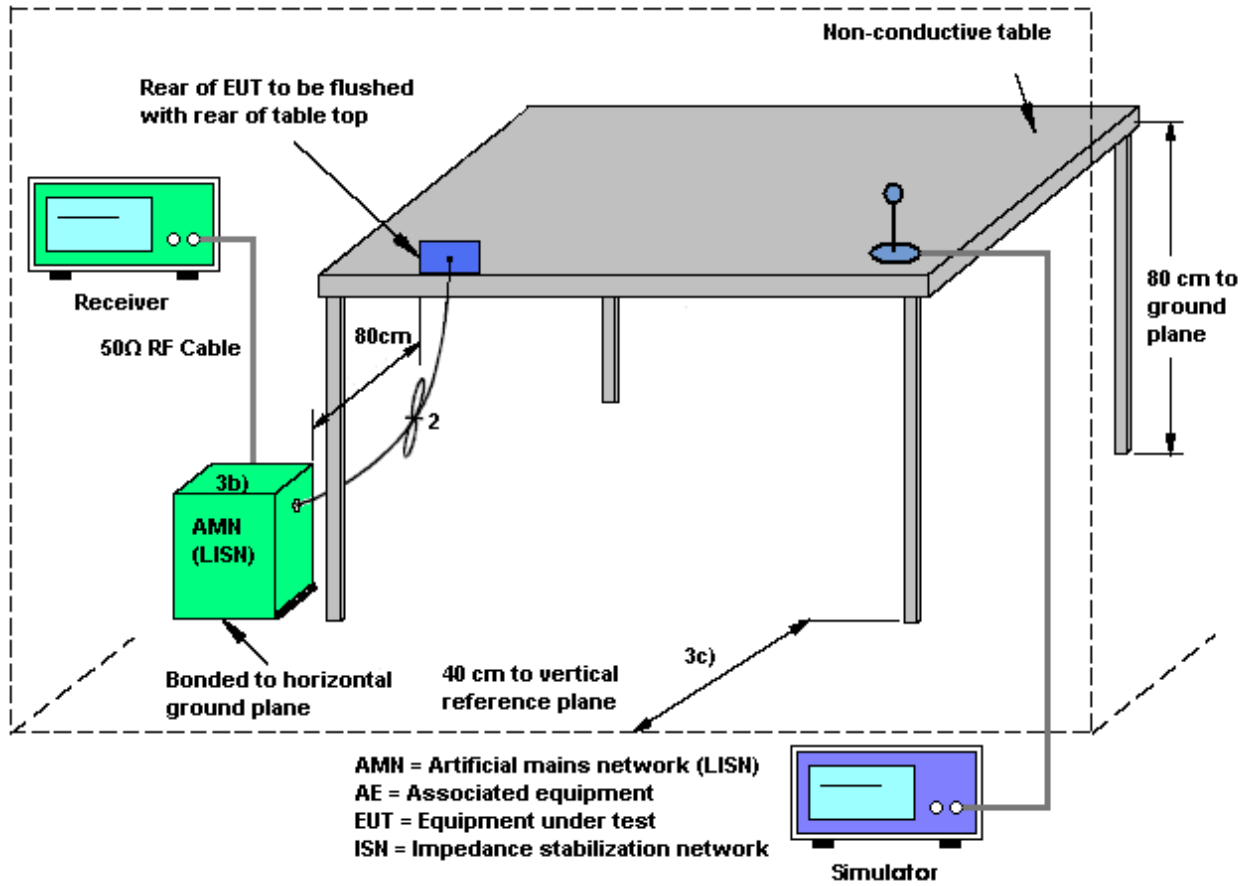

3.1.5 Test Result of AC Conducted Emission

Test Mode :	Mode 3	Temperature :	24~25°C
Test Engineer :	Cona Huang	Relative Humidity :	52~53%
		Phase :	Line
Function Type :	WCDMA Idle + GPS Rx + BT Idle + WLAN Idle + Earphone + USB Link + Camera + Adapter		
Remark :	All emissions not reported here are more than 10 dB below the prescribed limit.		

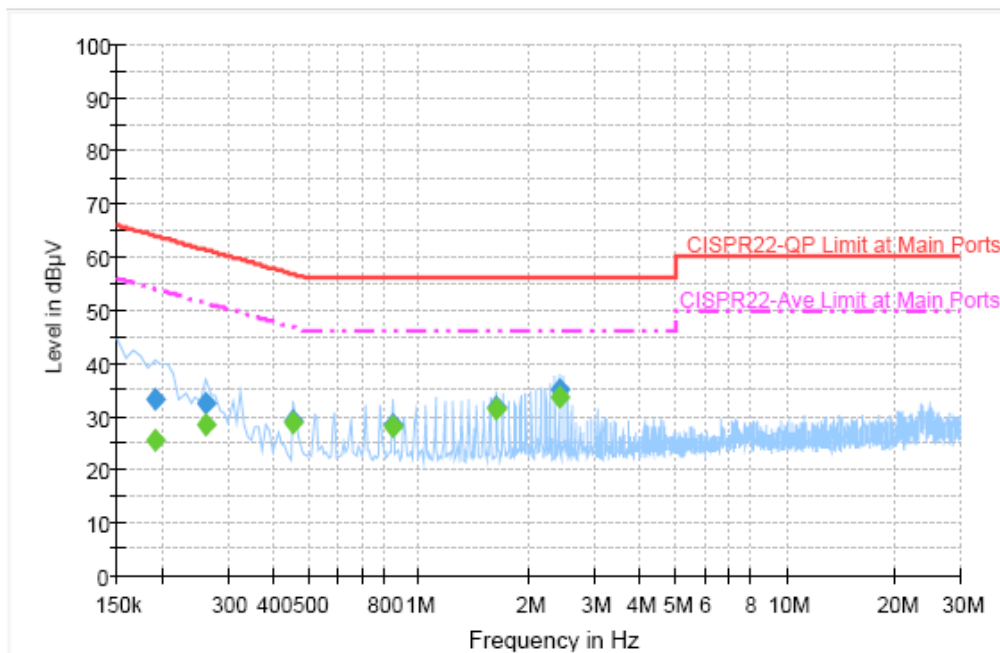

Final Result 1

Frequency (MHz)	QuasiPeak (dBµV)	Filter	Line	Corr. (dB)	Margin (dB)	Limit (dBµV)
0.190000	33.2	Off	L1	19.4	30.8	64.0
0.262000	32.5	Off	L1	19.3	28.9	61.4
0.454000	29.1	Off	L1	19.3	27.7	56.8
0.846000	28.5	Off	L1	19.5	27.5	56.0
1.630000	31.9	Off	L1	19.4	24.1	56.0
2.414000	35.0	Off	L1	19.5	21.0	56.0

Final Result 2

Frequency (MHz)	Average (dBµV)	Filter	Line	Corr. (dB)	Margin (dB)	Limit (dBµV)
0.190000	25.6	Off	L1	19.4	28.4	54.0
0.262000	28.4	Off	L1	19.3	23.0	51.4
0.454000	29.0	Off	L1	19.3	17.8	46.8
0.846000	28.0	Off	L1	19.5	18.0	46.0
1.630000	31.2	Off	L1	19.4	14.8	46.0
2.414000	33.5	Off	L1	19.5	12.5	46.0

Test Mode :	Mode 3	Temperature :	24~25°C
Test Engineer :	Cona Huang	Relative Humidity :	52~53%
		Phase :	Neutral
Function Type :	WCDMA Idle + GPS Rx + BT Idle + WLAN Idle + Earphone + USB Link + Camera + Adapter		
Remark :	All emissions not reported here are more than 10 dB below the prescribed limit.		

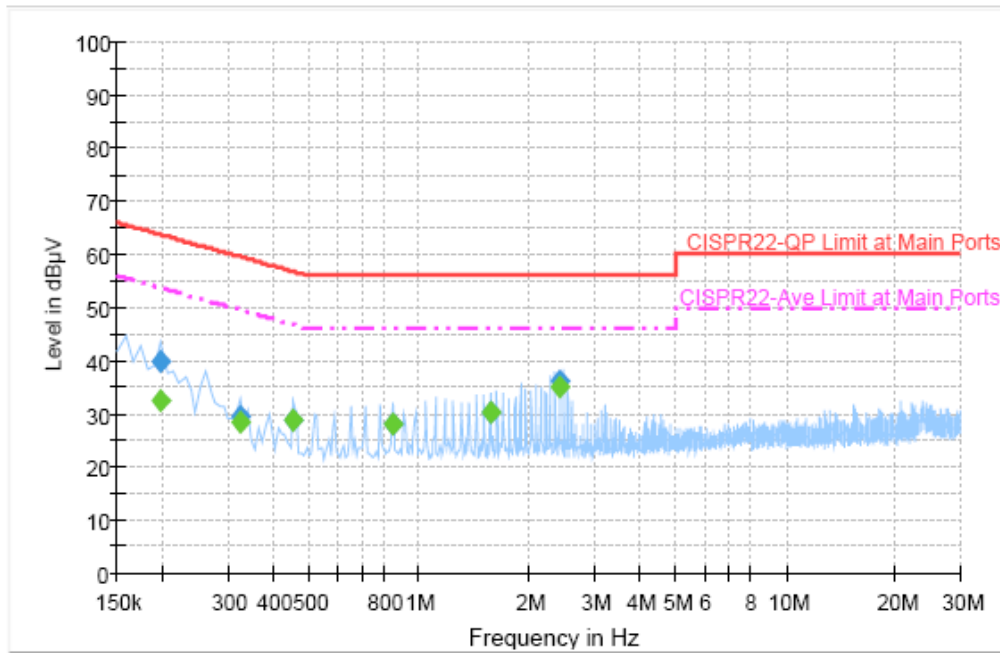

Final Result 1

Frequency (MHz)	QuasiPeak (dBµV)	Filter	Line	Corr. (dB)	Margin (dB)	Limit (dBµV)
0.198000	39.8	Off	N	19.3	23.9	63.7
0.326000	29.6	Off	N	19.3	30.0	59.6
0.454000	28.9	Off	N	19.3	27.9	56.8
0.846000	28.1	Off	N	19.5	27.9	56.0
1.566000	30.4	Off	N	19.4	25.6	56.0
2.414000	36.0	Off	N	19.5	20.0	56.0

Final Result 2

Frequency (MHz)	Average (dBµV)	Filter	Line	Corr. (dB)	Margin (dB)	Limit (dBµV)
0.198000	32.3	Off	N	19.3	21.4	53.7
0.326000	28.5	Off	N	19.3	21.1	49.6
0.454000	28.7	Off	N	19.3	18.1	46.8
0.846000	28.1	Off	N	19.5	17.9	46.0
1.566000	30.3	Off	N	19.4	15.7	46.0
2.414000	35.2	Off	N	19.5	10.8	46.0

3.2 Test of Radiated Emission Measurement

3.2.1 Limit of Radiated Emission

The emissions from an intentional radiator shall not exceed the field strength levels specified in the following table:

Frequency (MHz)	Field Strength (microvolts/meter)	Measurement Distance (meters)
0.009 – 0.490	2400/F(kHz)	300
0.490 – 1.705	24000/F(kHz)	30
1.705 – 30.0	30	30
30 – 88	100	3
88 – 216	150	3
216 - 960	200	3
Above 960	500	3

3.2.2 Measuring Instruments

See list of measuring instruments of this test report.

3.2.3 Test Procedures

1. The EUT was placed on a turntable with 0.8 meter above ground.
2. The EUT was set 3 meters from the interference receiving antenna, which was mounted on the top of a variable height antenna tower.
3. The table was rotated 360 degrees to determine the position of the highest radiation.
4. The antenna is a Bi-Log antenna and its height is adjusted between one meter and four meters above ground to find the maximum value of the field strength for both horizontal polarization and vertical polarization of the antenna.
5. For each suspected emission, the EUT was arranged to its worst case and then tune the antenna tower (from 1 m to 4 m) and turntable (from 0 degree to 360 degrees) to find the maximum reading.
6. Set the test-receiver system to Peak Detect Function and specified bandwidth with Maximum Hold Mode.
7. If the emission level of the EUT in peak mode was 3 dB lower than the limit specified, then testing will be stopped and peak values of EUT will be reported, otherwise, the emissions will be repeated one by one using the quasi-peak method and reported
8. Emission level (dBuV/m) = 20 log Emission level (uV/m)
9. Corrected Reading: Probe Factor + Cable Loss + Read Level - Preamp Factor = Level

3.2.4 Test Setup of Radiated Emission

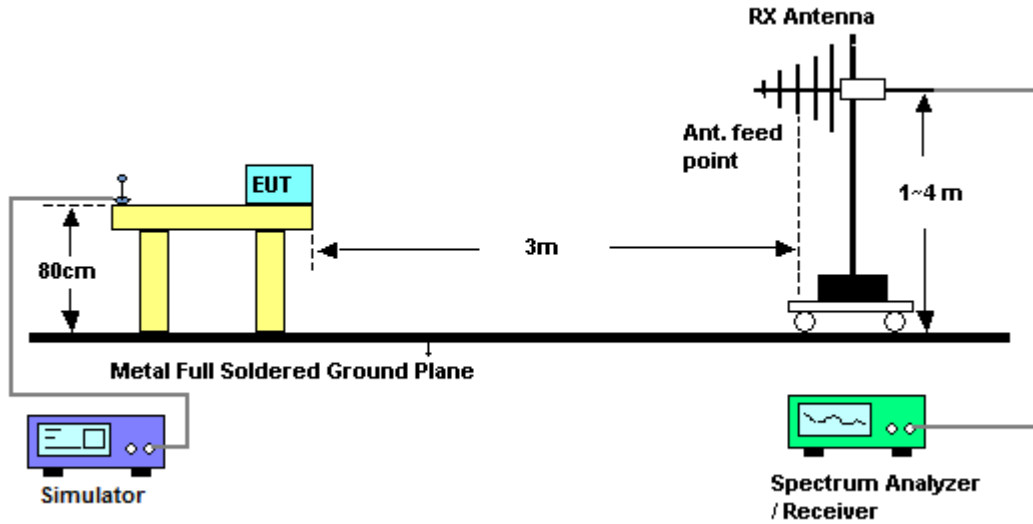



3.2.5 Test Result of Radiated Emission < 1GHz

Test Mode :	Mode 3	Temperature :	28~29°C
Test Engineer :	Mac Lin	Relative Humidity :	51~52%
Test Distance :	3m	Polarization :	Horizontal
Function Type :	WCDMA Idle + GPS Rx + BT Idle + WLAN Idle + Earphone + USB Link + Camera + Adapter		
Remark :	#6 is BS BCCH Signal.		

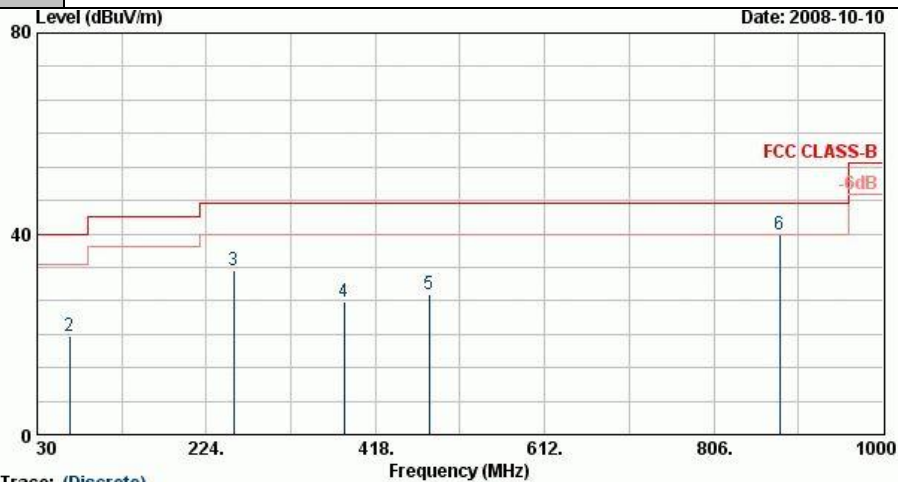

Trace: (Discrete)

Site : 03CH06-HY
 Condition : FCC CLASS-B 3m LF-ANT(051121) HORIZONTAL
 Model : FD 800405
 Memo : Mode 3

	Freq	Level	Over Limit	Limit Line	ReadAntenna Level	Antenna Factor	Cable Loss	Preamp Factor	Ant Pos	Table Pos	Remark
	MHz	dBuV/m	dB	dBuV/m	dBuV	dB/m	dB	dB	cm	deg	
1	30.00	22.63	-17.37	40.00	34.23	19.66	0.30	31.56	---	---	Peak
2	67.53	19.71	-20.29	40.00	44.30	6.84	0.40	31.83	---	---	Peak
3 @	255.18	32.66	-13.34	46.00	51.42	12.36	0.70	31.83	100	194	Peak
4	381.90	26.38	-19.62	46.00	42.00	15.31	0.88	31.82	---	---	Peak
5	479.90	27.82	-18.18	46.00	41.79	17.09	1.00	32.06	---	---	Peak
6 @	881.70	39.76	-6.24	46.00	50.00	20.40	1.30	31.94	---	---	Peak



Test Mode :	Mode 3	Temperature :	28~29°C
Test Engineer :	Mac Lin	Relative Humidity :	51~52%
Test Distance :	3m	Polarization :	Vertical
Function Type :	WCDMA Idle + GPS Rx + BT Idle + WLAN Idle + Earphone + USB Link + Camera + Adapter		
Remark :	#6 is BS BCCH Signal.		

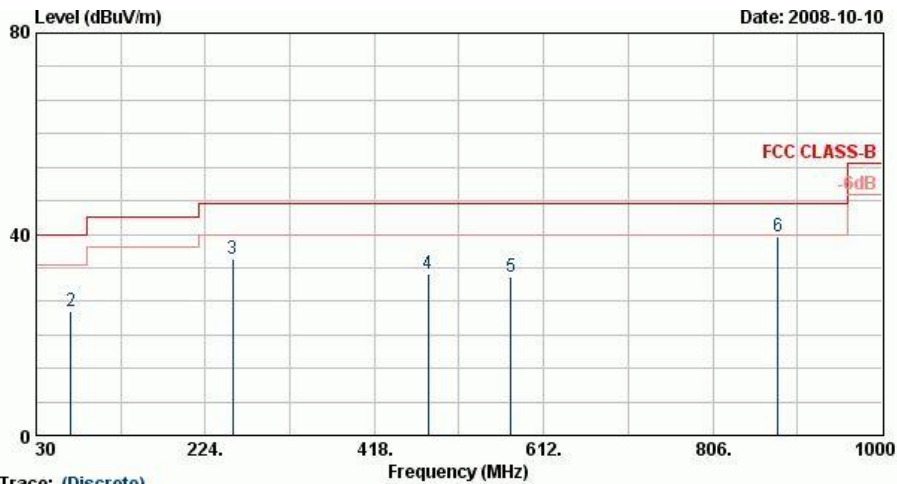

Trace: (Discrete)
 Site : 03CH06-HY
 Condition : FCC CLASS-B 3m LF-ANT(951121) VERTICAL
 Model : FD 800405
 Memo : Mode 3

	Freq	Level	Over Limit	Limit Line	ReadAntenna Level	Antenna Factor	Cable Loss	Preamp Factor	Ant Pos	Table Pos	Remark
	MHz	dBuV/m	dB	dBuV/m	dBuV	dB/m	dB	dB	cm	deg	
1	30.00	24.43	-15.57	40.00	36.03	19.66	0.30	31.56	---	---	Peak
2	69.69	24.64	-15.36	40.00	49.11	6.89	0.40	31.76	---	---	Peak
3	255.18	35.09	-10.91	46.00	53.85	12.36	0.70	31.83	100	215	Peak
4	479.90	32.08	-13.92	46.00	46.05	17.09	1.00	32.06	---	---	Peak
5	574.40	31.56	-14.44	46.00	44.51	18.20	1.00	32.15	---	---	Peak
6 @	880.30	39.66			49.92	20.39	1.30	31.95	---	---	Peak



3.2.6 Test Result of Radiated Emission ≥ 1 GHz

Test Mode :	Mode 1	Temperature :	28~29°C
Test Engineer :	Mac Lin	Relative Humidity :	51~52%
Test Distance :	3m	Polarization :	Horizontal
Function Type :	WCDMA Idle + GPS Rx + BT Idle + WLAN Idle + Earphone + USB Link + Camera + Adapter		

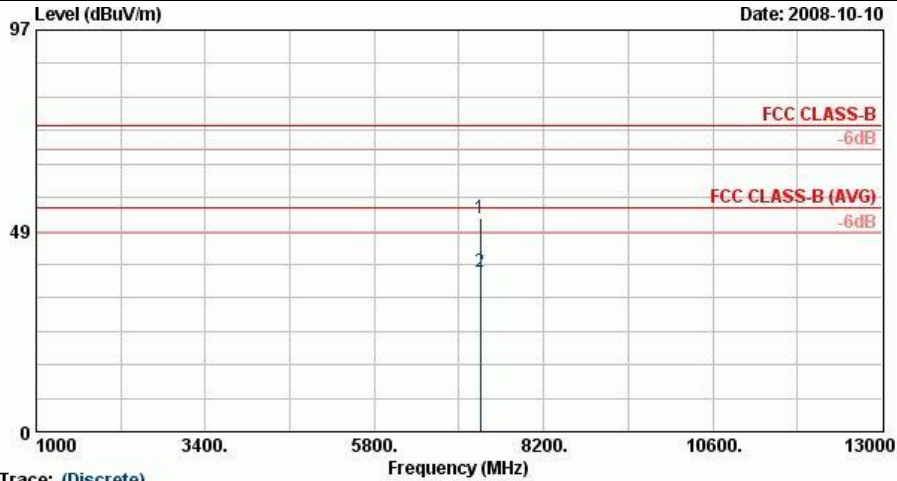

Trace: (Discrete)
 Site : 03CH06-HY
 Condition : FCC CLASS-B 3m HF-ANT(8-18)-060918 HORIZONTAL
 Model : FD 800405
 Memo : Mode 3

	Freq	Level	Over	Limit	Read	Antenna	Cable	Preamp	Ant	Table	
	MHz	dBuV/m	dB	dBuV/m	dBuV	dB/m	dB	dB	cm	deg	Remark
1	7304.00	51.68	-22.32	74.00	45.02	35.58	7.20	36.12	100	0	Peak
2 @	7304.00	38.62	-15.38	54.00	31.96	35.58	7.20	36.12	100	247	Average



Test Mode :	Mode 1	Temperature :	28~29°C
Test Engineer :	Mac Lin	Relative Humidity :	51~52%
Test Distance :	3m	Polarization :	Vertical
Function Type :	WCDMA Idle + GPS Rx + BT Idle + WLAN Idle + Earphone + USB Link + Camera + Adapter		

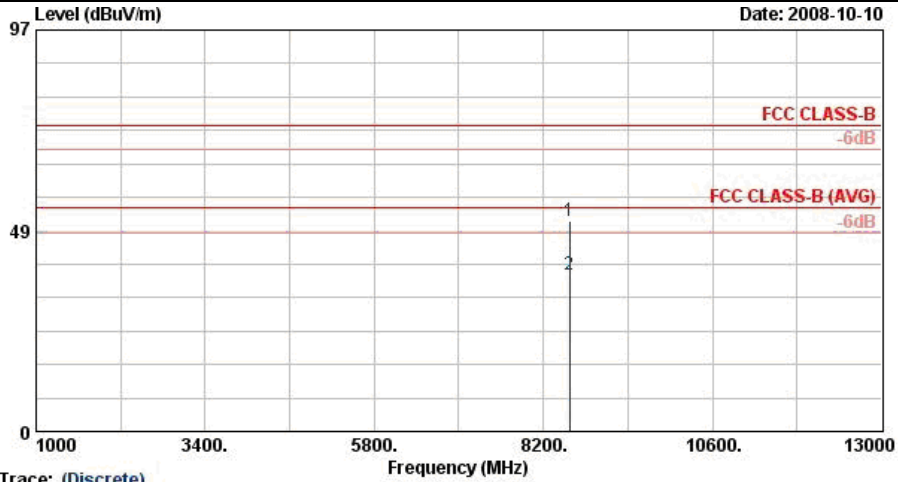

Trace: (Discrete)

Site : 03CH06-HY
 Condition : FCC CLASS-B 3m HF-ANT(8-16)-060918 VERTICAL
 Model : FD 800405
 Memo : Mode 3

	Freq	Level	Over Limit	Limit Line	ReadAntenna Level	Antenna Factor	Cable Loss	Preamp Factor	Ant Pos	Table Pos	Remark
	MHz	dBuV/m	dB	dBuV/m	dBuV	dB/m	dB	dB	cm	deg	
1	8574.00	50.78	-23.22	74.00	44.05	35.78	7.30	36.35	100	0	Peak
2 @	8574.00	38.03	-15.97	54.00	31.29	35.78	7.30	36.35	100	269	Average



4. List of Measuring Equipments

Instrument	Manufacturer	Model No.	Serial No.	Characteristics	Calibration Date	Due Date	Remark
EMI Receiver	R&S	ESCS 30	100356	9kHz~2.75GHz	Aug. 01, 2008	Jul. 31, 2009	Conduction (CO05-HY)
Two-LISN	R&S	ENV216	11-100081	9kHz~30MHz	Dec. 06, 2007	Dec. 05, 2008	Conduction (CO05-HY)
Two-LISN	R&S	ENV216	11-100080	9kHz~30MHz	Dec. 06, 2007	Dec. 05, 2008	Conduction (CO05-HY)
DC- LISN	R&S	ESH3-26	1000485	0.1MHz~200MHz	Feb. 04, 2008	Feb. 03, 2009	Conduction (CO05-HY)
DC- LISN	R&S	ESH3-26	1000484	0.1MHz~200MHz	Feb. 04, 2008	Feb. 03, 2009	Conduction (CO05-HY)
AC Power Source	APC	APC-1000W	N/A	N/A	N/A	N/A	Conduction (CO05-HY)
Base Station Simulator	R&S	CMU200	103937	Third-Band	Oct. 19, 2007	Oct. 18, 2008	Conduction (CO05-HY)
Spectrum Analyzer	Agilent	E4408B	MY44211028	9KHz~26.5GHz	Oct. 17, 2007	Oct. 16, 2008	Radiation (03CH06-HY)
EMI Test Receiver	R&S	ESVS10	834468/003	20MHz~1000MHz	Apr. 24, 2008	Apr. 23, 2009	Radiation (03CH06-HY)
Bilog Antenna	SCHAFFNER	CBL6112B	2885	30MHz~2GHz	Dec. 01, 2007	Nov. 30, 2008	Radiation (03CH06-HY)
Double Ridge Horn Antenna	EMCO	3117	00066583	1G~18GHz	Aug. 18, 2008	Aug. 17, 2009	Radiation (03CH06-HY)
Double Ridge Horn Antenna	Training Research	AF-0801	95119	8G~18GHz	Oct. 17, 2007	Oct. 16, 2008	Radiation (03CH06-HY)
SHF-EHF Horn	SCHWARZBECK	BBHA 9170	9170-251	14G~40GHz	Oct. 17, 2007	Oct. 16, 2008	Radiation (03CH06-HY)
Pre Amplifier	Agilent	8449B	3008A01917	1G~26.5GHz	Nov. 22, 2007	Nov. 21, 2008	Radiation (03CH06-HY)
Pre Amplifier	Agilent	310N	186713	9KHz~1GHz	Apr. 21, 2008	Apr. 20, 2009	Radiation (03CH06-HY)
Base Station Simulator	R&S	CMU200	103937	Third-Band	Oct. 19, 2007	Oct. 18, 2008	Radiation (03CH06-HY)

5. Uncertainty of Evaluation

Uncertainty of Conducted Emission Measurement (150 KHz ~ 30 MHz)

Contribution	Uncertainty of x_i		$u(x_i)$
	dB	Probability Distribution	
Receiver reading	0.10	Normal(k=2)	0.05
Cable loss	0.10	Normal(k=2)	0.05
AMN insertion loss	2.50	Rectangular	0.63
Receiver Spec	1.50	Rectangular	0.43
Site imperfection	1.39	Rectangular	0.80
Mismatch	+0.34/-0.35	U-shape	0.24
Combined standard uncertainty Uc(y)	1.13		
Measuring uncertainty for a level of confidence of 95% U=2Uc(y)	2.26		

Uncertainty of Radiated Emission Measurement (30 MHz ~ 1000 MHz)

Contribution	Uncertainty of x_i		$u(x_i)$
	dB	Probability Distribution	
Receiver reading	0.41	Normal(k=2)	0.21
Antenna factor calibration	0.83	Normal(k=2)	0.42
Cable loss calibration	0.25	Normal(k=2)	0.13
Pre Amplifier Gain calibration	0.27	Normal(k=2)	0.14
RCV/SPA specification	2.50	Rectangular	0.72
Antenna Factor Interpolation for Frequency	1.00	Rectangular	0.29
Site imperfection	1.43	Rectangular	0.83
Mismatch	+0.39/-0.41	U-shaped	0.28
Combined standard uncertainty Uc(y)	1.27		
Measuring uncertainty for a level of confidence of 95% U=2Uc(y)	2.54		



Uncertainty of Radiated Emission Measurement (1 GHz ~ 40 GHz)

Contribution	Uncertainty of x_i		$u(x_i)$	C_i	$C_i * u(x_i)$
	dB	Probability Distribution			
Receiver reading	±0.10	Normal(k=1)	0.10	1	0.10
Antenna factor calibration	±1.70	Normal(k=2)	0.85	1	0.85
Cable loss calibration	±0.50	Normal(k=2)	0.25	1	0.25
Receiver Correction	±2.00	Rectangular	1.15	1	1.15
Antenna Factor Directional	±1.50	Rectangular	0.87	1	0.87
Site imperfection	±2.80	Triangular	1.14	1	1.14
Mismatch Receiver VSWR $\Gamma_1 = 0.197$ Antenna VSWR $\Gamma_2 = 0.194$ Uncertainty = $20 \log(1 - \Gamma_1 * \Gamma_2)$	+0.34/-0.35	U-shaped	0.244	1	0.244
Combined standard uncertainty Uc(y)	2.36				
Measuring uncertainty for a level of confidence of 95% U=2Uc(y)	4.72				

6. Certification of NVLAP Accreditation

United States Department of Commerce
National Institute of Standards and Technology

NVLAP[®]

Certificate of Accreditation to ISO/IEC 17025:2005

NVLAP LAB CODE: 200079-0

Sporton International, Inc. Hwa Ya EMC Laboratory
Tao Yuan Hsien 333
TAIWAN

*is accredited by the National Voluntary Laboratory Accreditation Program for specific services,
listed on the Scope of Accreditation, for:*

ELECTROMAGNETIC COMPATIBILITY AND TELECOMMUNICATIONS

*This laboratory is accredited in accordance with the recognized International Standard ISO/IEC 17025:2005.
This accreditation demonstrates technical competence for a defined scope and the operation of a laboratory quality
management system (refer to joint ISO-ILAC-IAF Communique dated 18 June 2005).*

2008-01-01 through 2008-12-31
Effective dates



Sally S. Bruce
For the National Institute of Standards and Technology

NVLAP-01C (REV. 2006-09-13)



Appendix A. Photographs of EUT

Please refer to Sporton report number EP8O0405 as below.



1. External Photographs of EUT

Model Name: Juno SC





Model Name: Juno SC





Model Name: Juno SC





Model Name: Juno SC



Model Name: Juno SC



Model Name: Juno SC

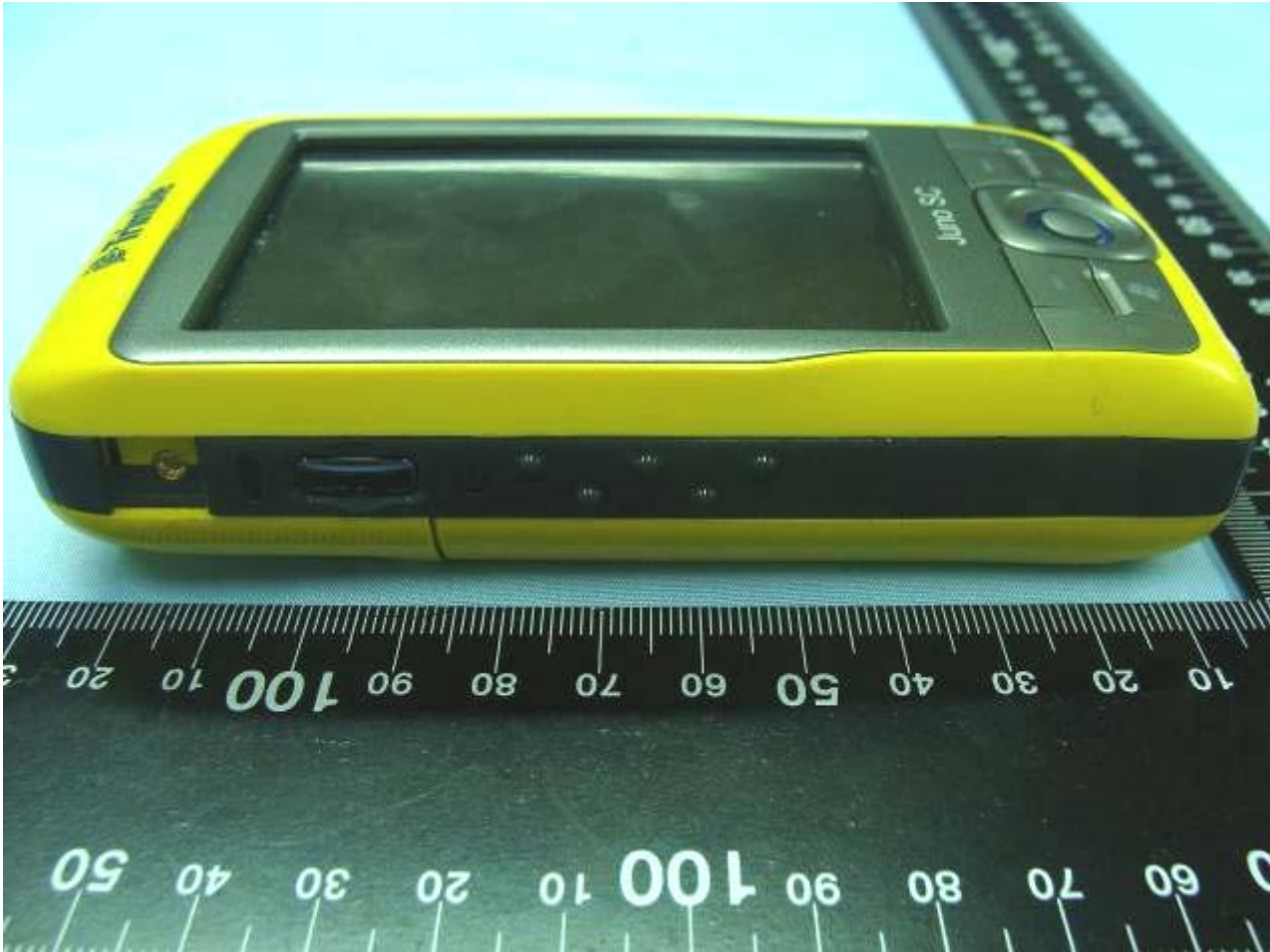

2. Photographs of Accessories

Model Name: Juno SC





Model Name: Juno SC





Model Name: Juno SC



Model Name: Juno SC





Model Name: Juno SC

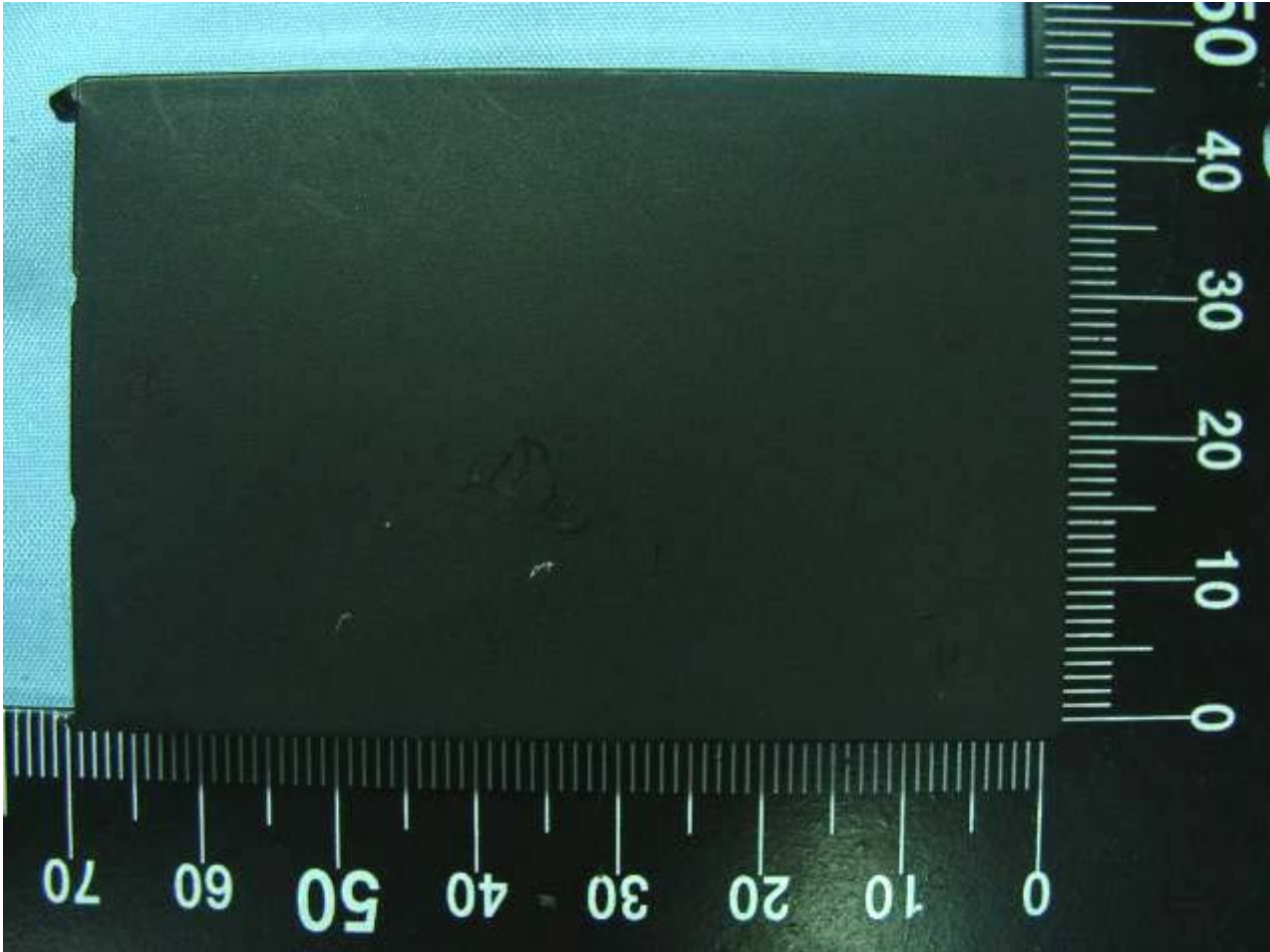

Model Name: Juno SC

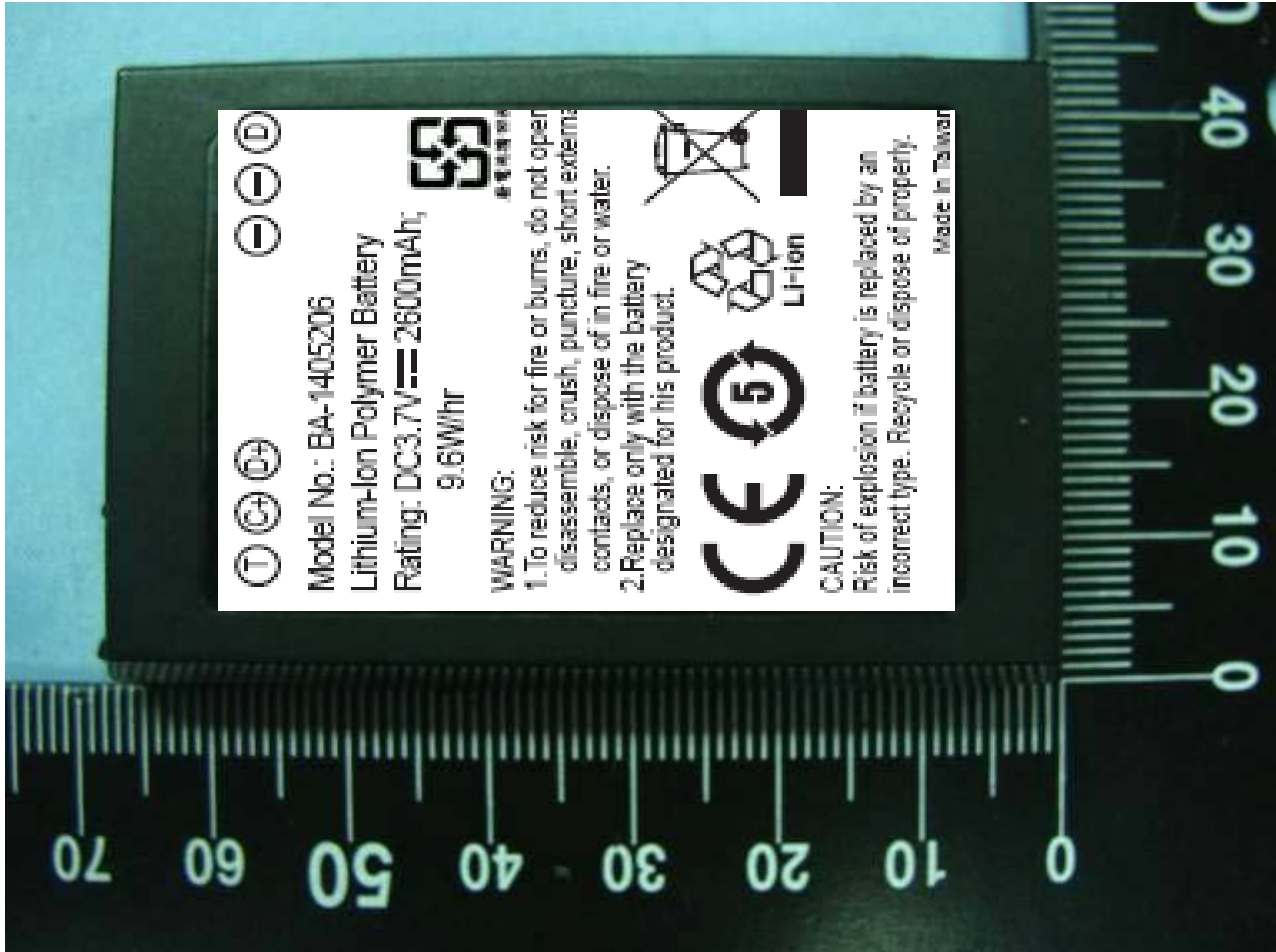

3. Internal Photographs of EUT

Model Name: Juno SC



Model Name: Juno SC



Model Name: Juno SC



Model Name: Juno SC





Model Name: Juno SC

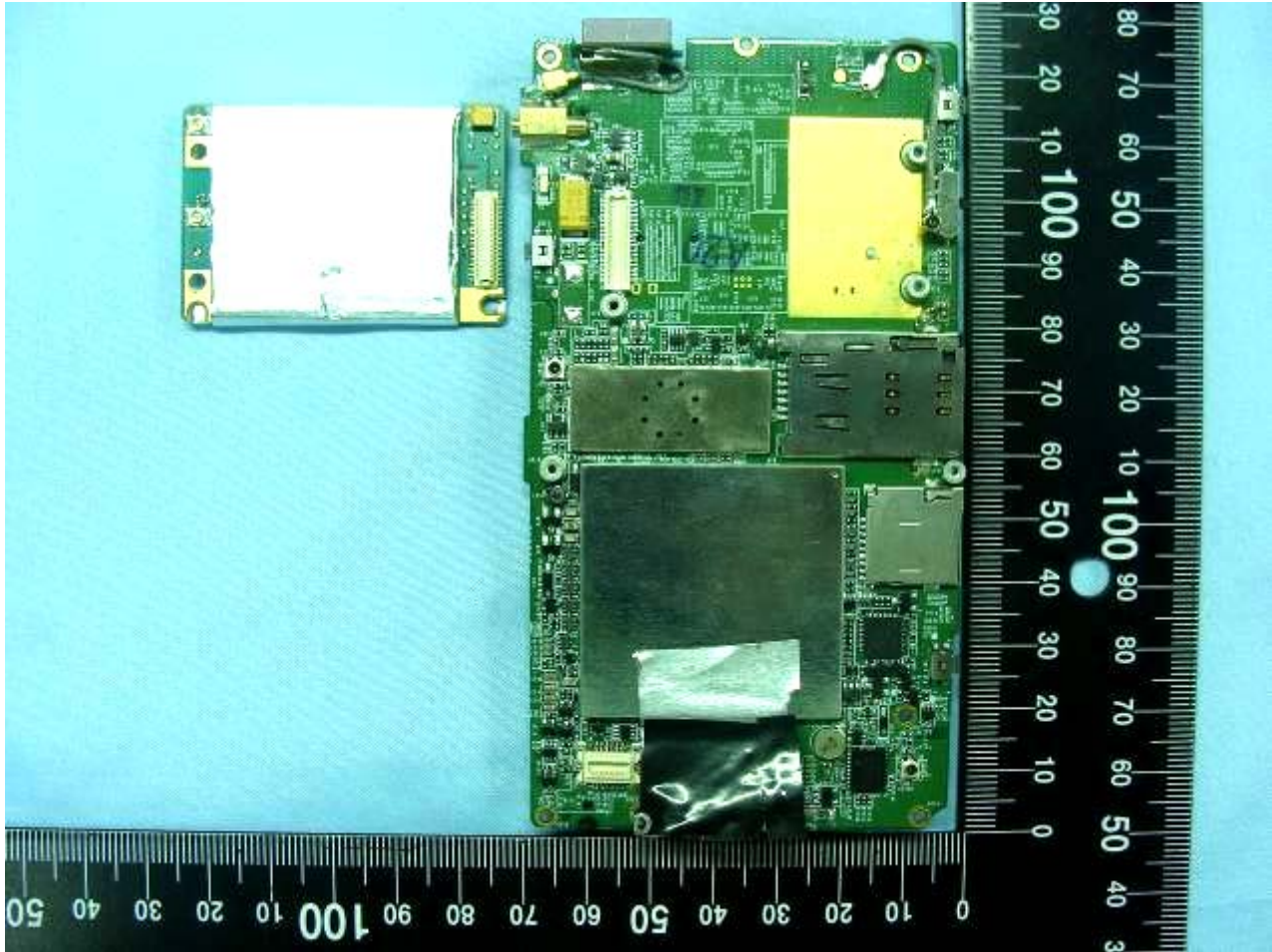

Model Name: Juno SC

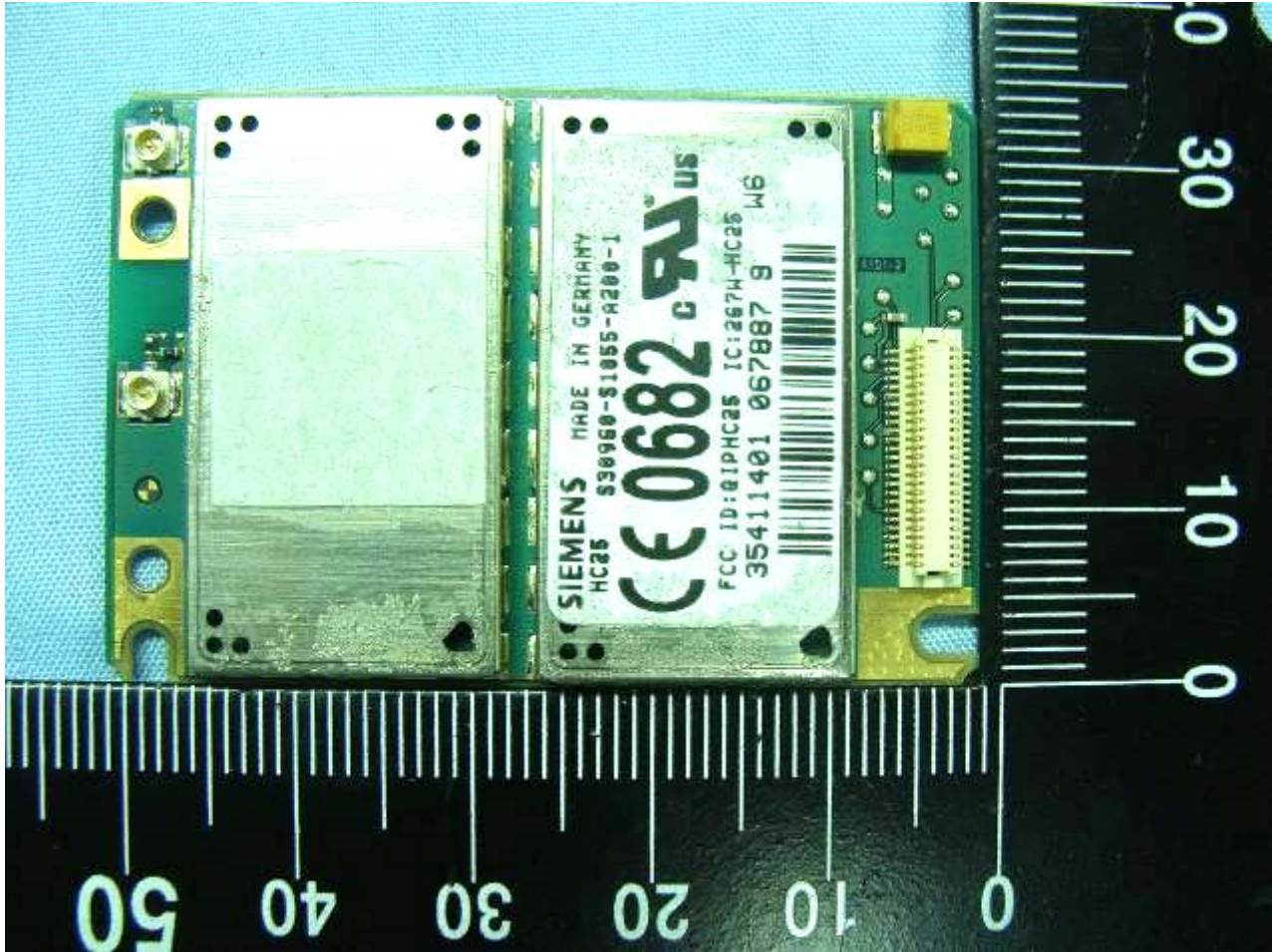

Model Name: Juno SC

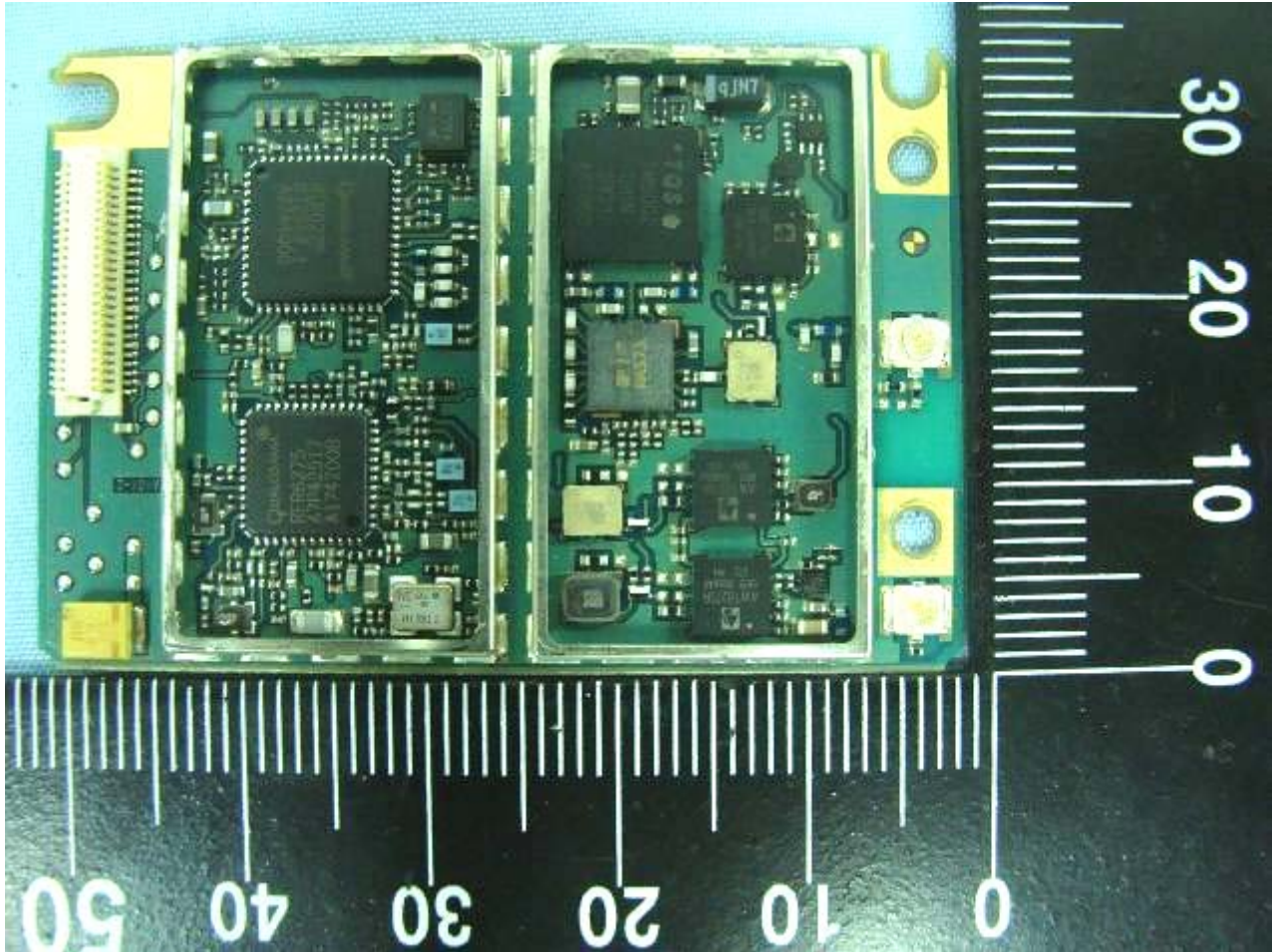

Model Name: Juno SC

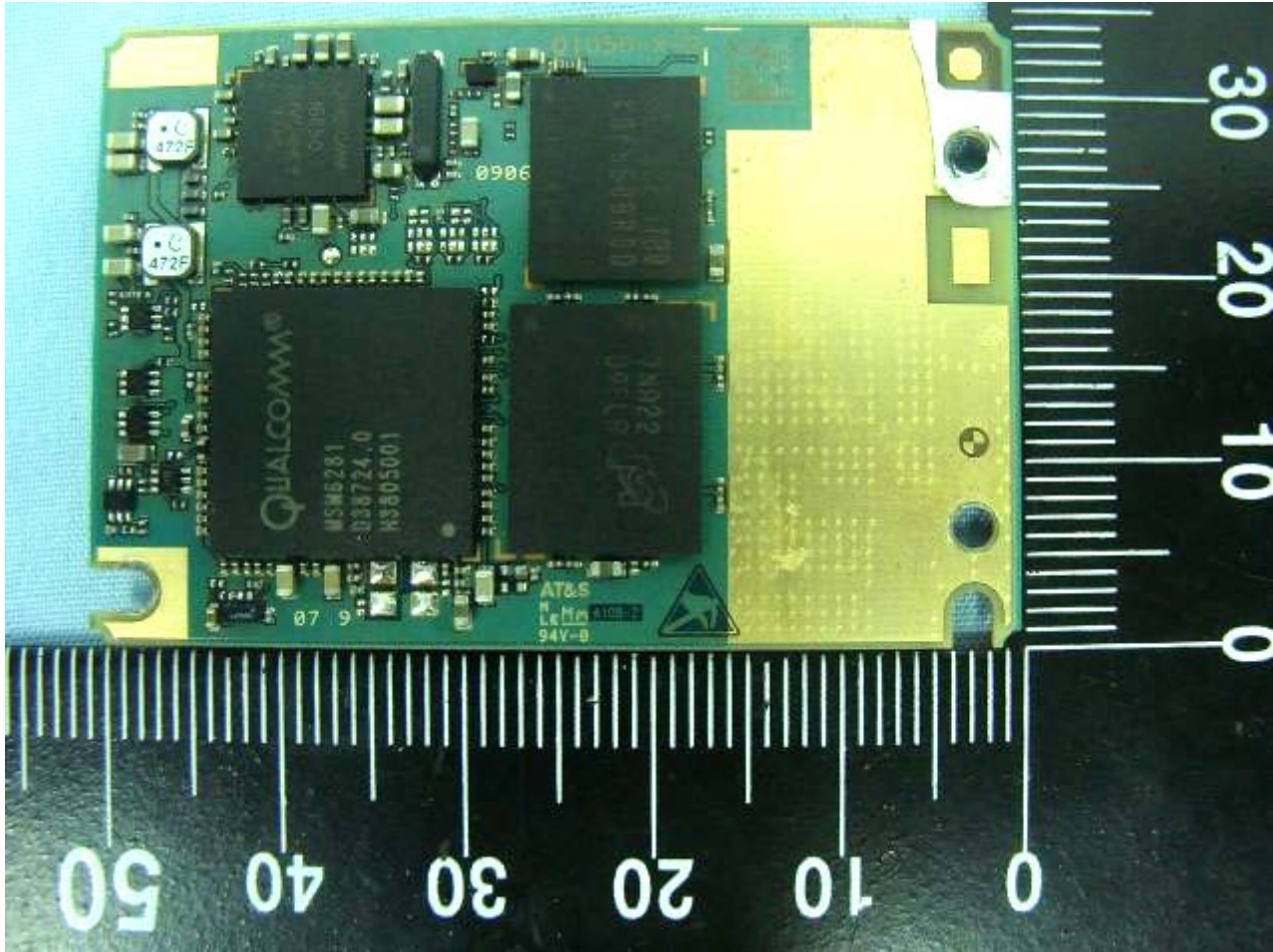

Model Name: Juno SC

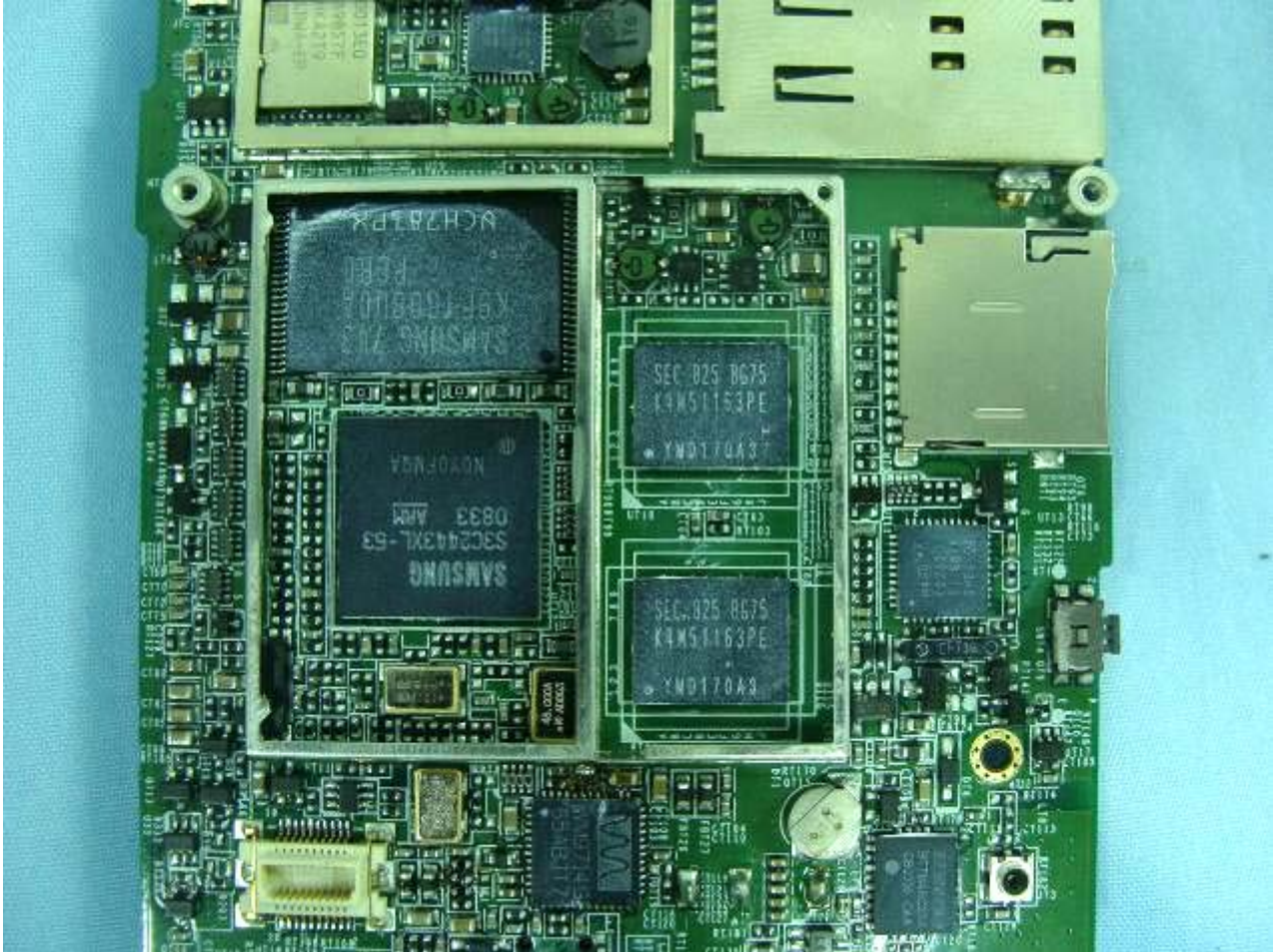

Model Name: Juno SC



Model Name: Juno SC

GSM ANT



Model Name: Juno SC

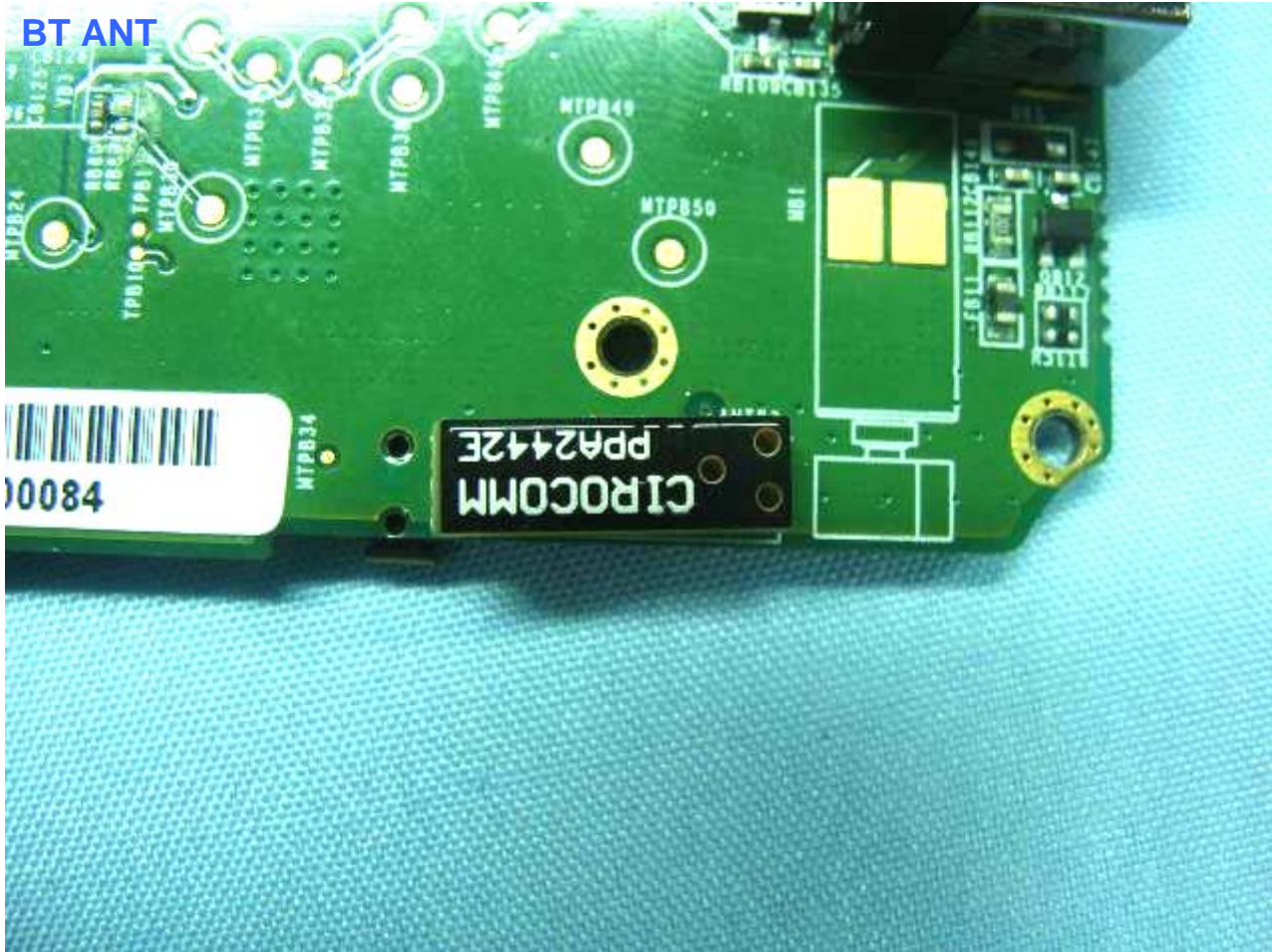

GSM Ant

Model Name: Juno SC



Appendix B. Setup Photographs

<Conducted Emission>

Front View



Rear View

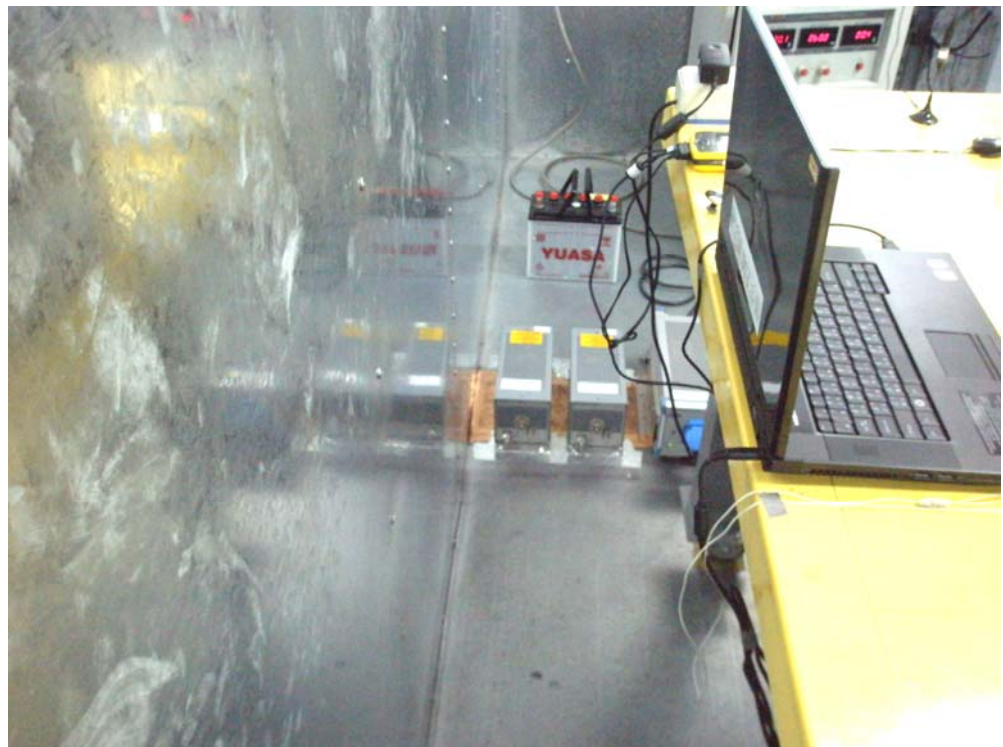

Side View



<Radiated Emission>

Front View

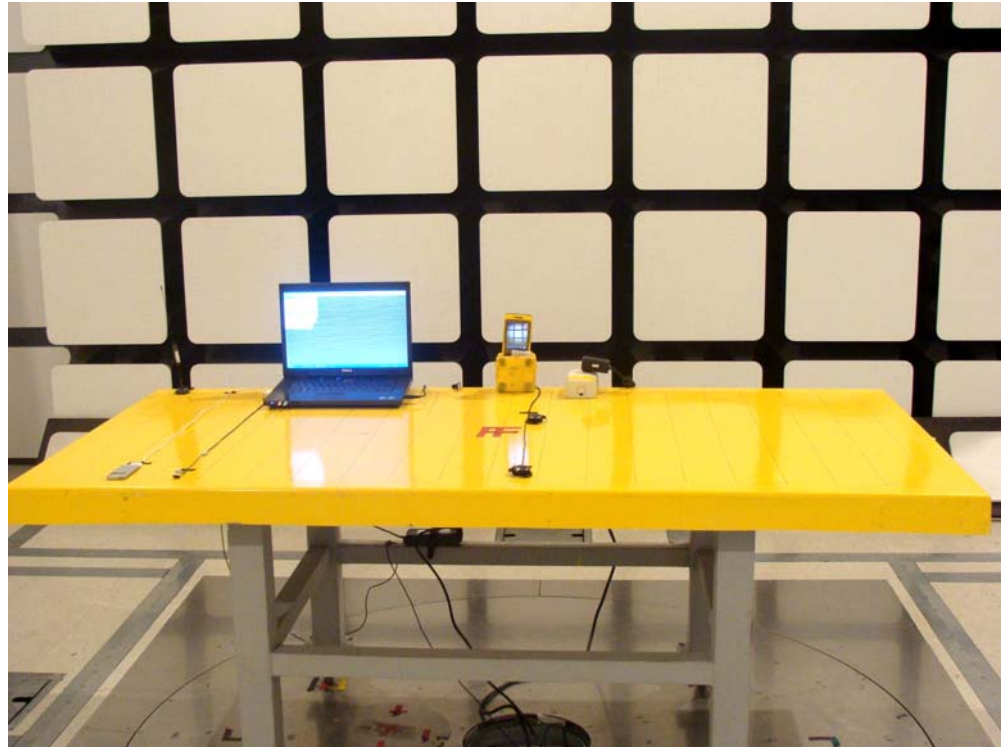

Rear View

