

802.11g Wireless LAN SiP Module (WM-BG-MR -01)



Data Sheet Apr 28'th. 2005 Rev 2.2

www.usi.com.tw

PRODUCT SPECIFICATION of 802.11g WM-BG-MR -01 B2B Wireless Lan +BT Combo Module

All rights are reserved by USI. No part of this technical document can be reproduced in any form without permission of USI.

Preliminary release for evaluation, Subject to be changed without Notice

802.11g Wireless LAN+BT SiP combo Module V2.2

Introduction

The 802.11 Wireless SiP module WMBG-MR-01 which refers as “SiP-g combo module” is a small size module that provides full function of 802.11g/b and Bluetooth class 2 on a tiny module via 60 pins board to board connector.

This multi- functionality and board to board physical interface provides 16 bit PC Card /CF+ bus interface for WiFi and UART for Bluetooth.

The small size & low profile physical design make it easier for system design to enable high performance wireless connectivity without space constrain. The low power consumption (**Sleep mode 1 mA**) and excellent radio performance make it the best solution for OEM customers who require embedded 802.11g Wi-Fi + Bluetooth features, such as, Wireless PDA, Scanner Smart phone, Media player slim type Notebook, barcode ,mini-Printer, VoIP phone etc.

For 802.11g feature, Marvell “Libertas” chipset solution is adopted and CSR BlueCore 03-ROM for Bluetooth. The Radio architecture & high integration MAC/BB chip provide excellent sensitivity with rich system performance. Two antenna connectors provide antenna connectivity for each function.

WM-BG-AG-01 provides outstanding BT WiFi co-existence solution through internal 2 wires , hardware interface to optimized connection with CSR Bluetooth solution even without good antenna isolation between BT & WiFi module.

In addition to WEP 64/128, WPA and TKIP, AES is supported to provide the latest security requirement on your network.

For the software and driver development, USI provides extensive technical document and reference software code for the system integration under the agreement of Marvell International Ltd.

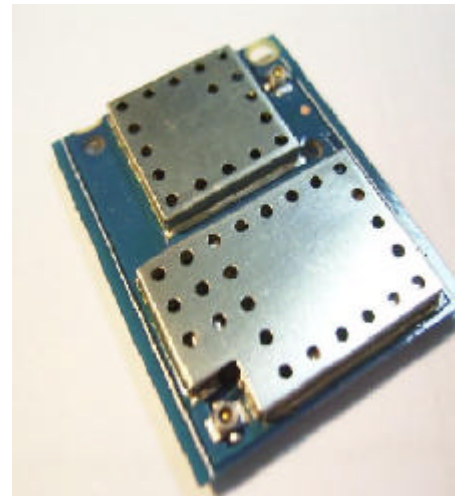

Features

- Lead Free design which supporting Green design requirement.
- 2 wires, hardware signaling BT WiFi co-existence supported.
- Small size suitable for low volume system integration. PCM audio interface supported.
- Low power consumption & excellent power management performance, extend battery life.
- 2.412-2.484 GHz two SKUs for worldwide market.
- Easy for integration into mobile and handheld device with flexible system configuration and antenna design.



All rights are reserved by USI. No part of this technical document can be reproduced in any form without permission of USI.

Preliminary release for evaluation, Subject to be changed without Notice

802.11g Wireless LAN+BT SiP combo Module V2.2

Change Sheet					
Rev.	Date	Description of change			Approval & Date
		Page	Par	Change(s)	
1.0	10/1/04	All	All	Draft version for Review	
2.0	04/11/05	6,15, 17,22 ,23, 25~2 7		<ol style="list-style-type: none"> 1. Executive summary for target available date from "the middle of 1Q 2005" to "the end of 2Q" 2. Output power for 11g is 13 +/- 1dBm 3. Update the mech. Drawing . 4. Modify the function description for Marvell Transceiver from "8010" to "8015" 5. Correct the Pin Definition for xxx_B is for "active_high" 6. add description for Pin 28;36;43;58 ; which reserved for BT's PCM interface , make it no confuse in customer reading. 	
2.1	04/18/05	25		1. correct the pin definition for Pin24 from "Control signal to enable engineer testing mode " to "Output signal to indicate 16 bit IO operation. This signal is connected to ground at module side to indicate 16 bit IO." then Type is for GND to indicate the module under the mode for 16bit IO.	
2.2	04/28/05	24		1. Pin A10 pin definition change from " the pin is open to "This address range is mainly used for accessing the CIS in Memory Mode. Signal HA0 is not used in word access mode." , Type change from " No connection" to "Input , PD,5VT"	

All rights are reserved by USI. No part of this technical document can be reproduced in any form without permission of USI.

Preliminary release for evaluation, Subject to be changed without Notice

802.11g Wireless LAN+BT SiP combo Module V2.2

TABLE OF CONTENTS

1. EXECUTIVE SUMMARY	6
2. DELIVERABLES	6
3. REFERENCE DOCUMENTS	7
4. TECHNICAL SPECIFICATION	8
4.1. ABSOLUTE MAXIMUM RATING	8
4.2. RECOMMENDABLE OPERATION CONDITION	8
4.2.1. TEMPERATURE, HUMIDITY	8
4.2.1. VOLTAGE AND CURRENT	8
BLUETOOTH.....	8
4.3. COMPACTFLASH SPECIFICATION	9
4.3.1. DC ELECTRICALS.....	9
4.3.2. AC ELECTRICALS	9
4.3.3. COMPACTFLASH PROTOCOL TIMING	10
4.4. WIRELESS SPECIFICATIONS	14
4.5. RADIO SPECIFICATIONS 802.11G	15
4.6. RADIO SPECIFICATIONS 802.15 BLUETOOTH	15
4.7. BLUETOOTH RADIO CHARACTERISTICS.....	16
4.8. DIMENSIONS, WEIGHT AND MOUNTING.....	17
4.8.1. DIMENSIONS	17
4.8.2. WEIGHT	17
4.8.3. MOUNTING	17
4.9. SHOCK AND VIBRATION.....	17
5. COMPATIBILITY AND INTEROPERABILITY	18
5.1. WI-FI LOGO	18
5.2. WHQL COMPLIANCE	18
6. CONFIGURABILITY	18
7. SECURITY	18
8. OPERATING SYSTEM COMPATIBILITY.....	18
9. LEGAL, REGULATORY & OTHER TECHNICAL CONSTRAINTS.....	18
9.1. EMC	19
9.2. PRODUCT SAFETY SPECIFICATION	19
9.3. COMPONENT SPECIFICATION	19
9.4. RADIO REQUIREMENTS AND APPROVALS	20
9.5. PRODUCT MARKING	21
9.6. ENVIRONMENTALLY SAFE MATERIAL RESTRICTIONS	21
10. FUNCTIONAL DESCRIPTION.....	22
10.1. HARDWARE	22
10.2. HOST INTERFACE	23

All rights are reserved by USI. No part of this technical document can be reproduced in any form without permission of USI.

Preliminary release for evaluation, Subject to be changed without Notice

802.11g Wireless LAN+BT SiP combo Module V2.2

10.2.1.	LED INTERFACE	27
10.2.2.	ANTENNA INTERFACE.....	27
10.2.3.	BLUETOOTH INTERFACE	28
10.3.	SOFTWARE.....	28
11.	DESIGN FOR EXCELLENCE (DFX).....	28
11.1.	TESTABILITY	28
11.2.	LOGISTICS.....	28
12.	HUMAN FACTORS.....	29
13.	INDUSTRIAL DESIGN.....	29
14.	RELIABILITY.....	29
15.	PACKAGE.....	29

All rights are reserved by USI. No part of this technical document can be reproduced in any form without permission of USI.

Preliminary release for evaluation, Subject to be changed without Notice

802.11g Wireless LAN+BT SiP combo Module V2.2

1. EXECUTIVE SUMMARY

The WM-BG-MR-01 module - is one of the product families in USI's product offering, targeting for system integration requiring a smaller form factor. It also provides the standard migration to high data rate to USI's current SIP customers. The WM-BG-MR-01 module providing B to B type connector is provided as option for customers, who want to have Board to board type assembly.

This document outlines the product requirements for a "system in Package" 802.11g/(b) combo module – here after referred as WM-BG-MR-01 Module.

This product is targeted for first shipments by end of **2Q 2005** and is designated for use in embedded applications mainly in the mobile device, which required, small size and high data rate wireless connectivity. The application such as, Wireless PDA, slim type Notebook, Media Adapter, Barcode scanner, mini-Printer, VoIP phone, Data storage device could be the potential application for wireless WM-BG-MR-01.

2. DELIVERABLES

The following products and software will be part of the product.

- WM-BG-MR-01 Module with packaging
- Evaluation kits, including application (CF, PCMCIA Adapter card, RF cable with SMA connector, antenna),
- Software utility which supporting customer for integration, performance test, and homologation. Capable of testing, loading (firmware) and configuring (MAC, CIS) for the WM-BG-MR-01 module.
- Unit Test / Qualification report
- Product Specifications.
- Agency certification pre-test report base on adapter boards

All rights are reserved by USI. No part of this technical document can be reproduced in any form without permission of USI.

Preliminary release for evaluation, Subject to be changed without Notice

802.11g Wireless LAN+BT SiP combo Module V2.2

3. REFERENCE DOCUMENTS

C.I.S.P.R. Pub. 22	"Limits and methods of measurement of radio interference characteristics of information technology equipment." International Special Committee on Radio Interference (C.I.S.P.R.), Third Edition, 1997.
CB Bulletin No. 96A	"Adherence to IEC Standards: "Requirements for IEC 950, 2 nd Edition and Amendments 1 (1991), 2(1993), 3 (1995) and 4(1996). Product Categories: Meas, Med, Off, Tron." IEC System for Conformity Testing to Standards for Safety of Electrical Equipment (IECEE), April 2000.
CFR 47, Part 15-B	"Unintentional Radiators". Title 47 of the Code of Federal Regulations, Part 15, FCC Rules, Radio Frequency Devices, Subpart B.
CFR 47, Part 15-C	"Intentional Radiators". Title 47 of the Code of Federal Regulations, Part 15, FCC Rules, Subpart C. URL: http://www.access.gpo.gov/nara/cfr/waisidx_98/47cfr15_98.html
CSA C22.2 No. 950-95	"Safety of Information Technology Equipment including Electrical Business Equipment, Third Edition." Canadian Standards Association, 1995, including revised pages through July 1997.
EN 60 950	"Safety of Information Technology Equipment Including Electrical Business Equipment." European Committee for Electrotechnical Standardization (CENELEC), 1996, (IEC 950, Second Edition, including Amendment 1, 2, 3 and 4).
IEC 950	"Safety of Information Technology Equipment Including Electrical Business Equipment." European Committee for Electrotechnical Standardization, Intentional Electrotechnical Commission. 1991, Second Edition, including Amendments 1, 2, 3, and 4.
IEEE 802.11	"Wireless LAN Medium Access Control (MAC) And Physical Layer (PHY) Specifications." Institute of Electrical and Electronics Engineers. 1999.

All rights are reserved by USI. No part of this technical document can be reproduced in any form without permission of USI.

Preliminary release for evaluation, Subject to be changed without Notice

802.11g Wireless LAN+BT SiP combo Module V2.2

4. TECHNICAL SPECIFICATION

The WM-BG-MR-01 is a B2B type assembly part, technical supporting, package requirement needs to be taken into consideration.

4.1. ABSOLUTE MAXIMUM RATING

Supply Power	Max +3.6 Volt	
Non Operating Temperature	- 40° to 85° Celsius	
Voltage ripple	+/- 2%	Max. Values not exceeding Operating voltage

4.2. RECOMMENDABLE OPERATION CONDITION

4.2.1. TEMPERATURE, HUMIDITY

The WM-BG-MR-01 module has to withstand the operational requirements as listed in the table below.

Operating Temperature	-20° to 60° Celsius	
Humidity range	Max 95%	Non condensing, relative humidity

4.2.1. VOLTAGE AND CURRENT

Power supply for the WM-BG-MR-01 module will be provided by the host via the power pins
There will be separated power source for WiFi and Bluetooth.

802.11 g(b)

Voltage : VDD

Operating Voltage	3.3 Volt	+/- 10%
-------------------	----------	---------

Current

Transmit	450 mA	Typical
Receive	275 mA	
Sleep connected	1mA	Average
Inrush current	3000 mA	Max.

The power consumption is standard related.

Bluetooth

Voltage : VDD

Operating Voltage	3.3 Volt	+/- 10%
-------------------	----------	---------

All rights are reserved by USI. No part of this technical document can be reproduced in any form without permission of USI.

Preliminary release for evaluation, Subject to be changed without Notice

802.11g Wireless LAN+BT SiP combo Module V2.2

Current		
Transmit	50 mA	Typical
Receive	?40 mA	
Sleep connected	? mA	Average

4.3. COMPACTFLASH SPECIFICATION

4.3.1. DC ELECTRICALS

The DC specification is under 3.3 voltage. Over full range of values specified in the “Recommended Operation Condition” unless specified.

Power supply : VDD=3.3V

Symbol	Parameter	Condition	Min	Typ	Max	Units
V _{IH}	Input high voltage		0.5 VDD	-	VDD+0.5	V
V _{IL}	Input low voltage		-0.5	-	0.35VDD	V
V _{OH}	Output high voltage		2.4	-	-	V
V _{OL}	Output low voltage		-	-	0.4	V

4.3.2. AC ELECTRICALS

The DC specification is under 3.3 voltage. Over full range of values specified in the “Recommended Operation Condition” unless specified.

Power supply : VDD = 3.3V

Symbol	Parameter	Condition	Min	Typ	Max	Units
I _{OH}	Input high voltage	=0.7 VDD	11.3	-	32	mA
I _{OL}	Input low voltage	=0.18VDD	10.5	-	38	mA
V _{OH}	Output high voltage	0.2VDD- 0.6VDD	2.4	0.518	4.0	V/ns
V _{OL}	Output low voltage	0.6VDD-0.2VDD	-	0.592	4.0	V/ns

All rights are reserved by USI. No part of this technical document can be reproduced in any form without permission of USI.

Preliminary release for evaluation, Subject to be changed without Notice

802.11g Wireless LAN+BT SiP combo Module V2.2

4.3.3. COMPACTFLASH PROTOCOL TIMING

4.3.3.1. RESET SPECIFICATION

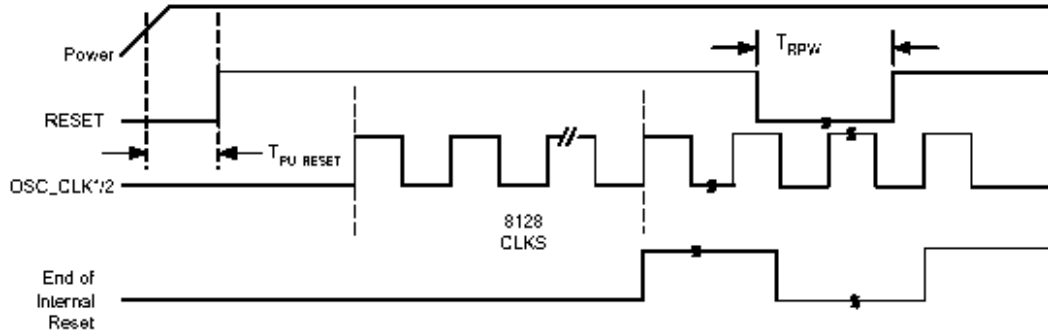

RESETn is not needed for proper operation due to internal power-on reset logic.

Input Reset Timing Requirement

Over full range of values specified in the Recommended Operating Conditions unless otherwise specified.

Symbol	Parameter	Condition	Min	Typ	Max	Units
T_{RPW}	RESETn pulse width			100 ns	--	

All rights are reserved by USI. No part of this technical document can be reproduced in any form without permission of USI.

Preliminary release for evaluation, Subject to be changed without Notice

802.11g Wireless LAN+BT SiP combo Module V2.2

4.3.3.2. ATTRIBUTE MEMORY READ/WRITE TIMING SPECIFICATION

CompactFlash Configuration Register Write Timing Diagram

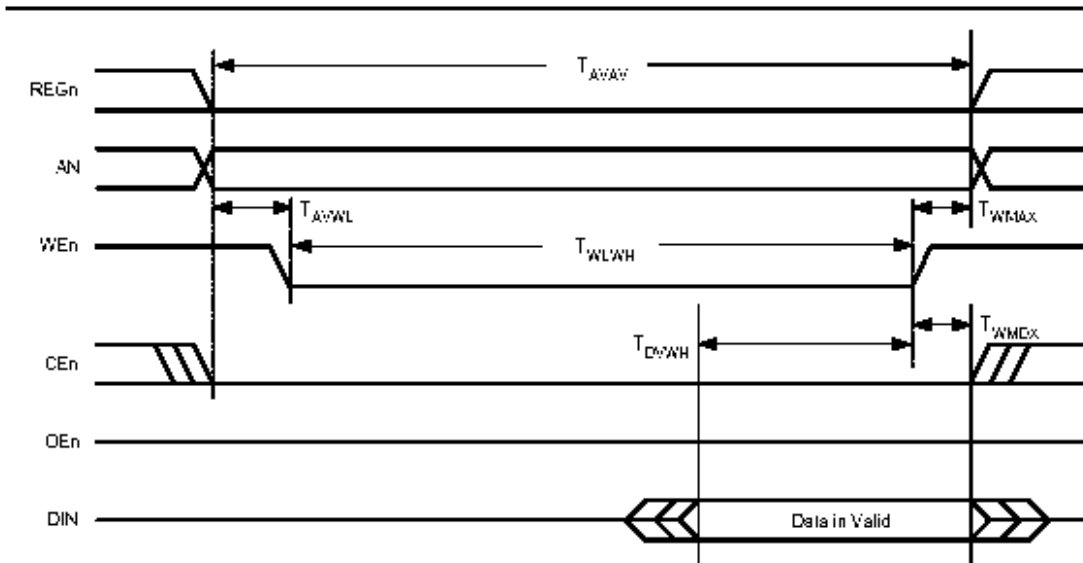

CompactFlash Write Timing Data

Over full range of values specified in the Recommended Operating Conditions unless otherwise specified.

Symbol	Parameter	Condition	Min	Typ	Max	Units
T_{AWAV}	Write Cycle Time		250	--	--	ns
T_{WLWH}	Write Pulse Width		150	--	--	ns
T_{AVWL}	Address Setup Time		30	--	--	ns
T_{WMAX}	Write Recovery Time		30	--	--	ns
T_{DVWH}	Data Setup Time for WE		80	--	--	ns
T_{WMDX}	Data Hold Time		30	--	--	ns

All rights are reserved by USI. No part of this technical document can be reproduced in any form without permission of USI.

Preliminary release for evaluation, Subject to be changed without Notice

802.11g Wireless LAN+BT SiP combo Module V2.2

CompactFlash Configuration Register Read Timing Diagram

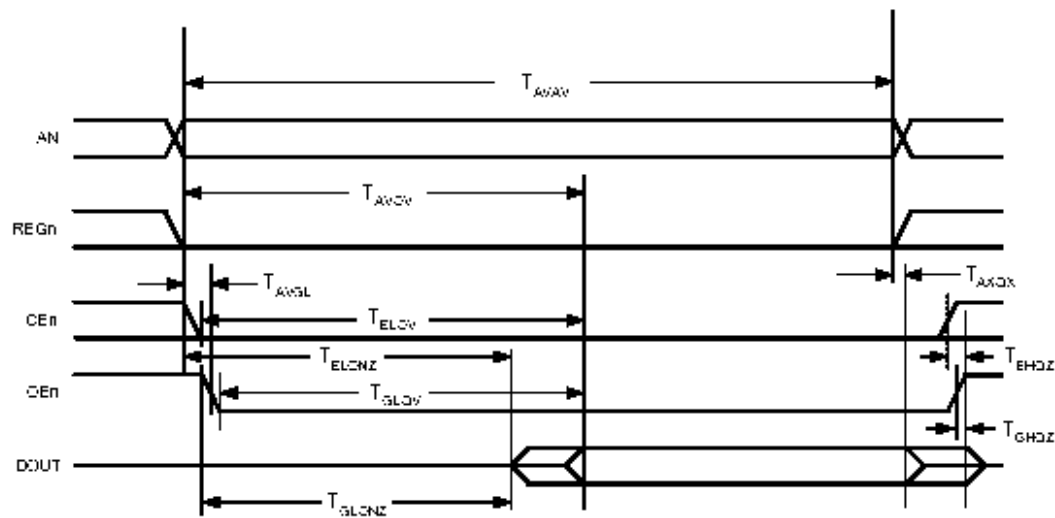

CompactFlash Read Timing Data

Over full range of values specified in the Recommended Operating Conditions unless otherwise specified.

Symbol	Parameter	Condition	Min	Typ	Max	Units
T_{AVAV}	Read Cycle Time		300	--	--	ns
T_{AVGV}	Address Access Time		--	--	300	ns
T_{ELOV}	Card Enable Access Time		--	--	300	ns
T_{GLOV}	Output Enable Access Time		--	--	150	ns
T_{EHGVZ}	Output Disable Time from CE		--	--	100	ns
T_{GHGVZ}	Output Disable Time from OE		--	--	100	ns
T_{AVGL}	Address Setup Time		30	--	--	ns
T_{ELOVZ}	Output Enable Time from CE		5	--	--	ns
T_{GLOVZ}	Output Enable Time from OE		5	--	--	ns
T_{AXGV}	Data Valid from Address Change		0	--	--	ns

All rights are reserved by USI. No part of this technical document can be reproduced in any form without permission of USI.

Preliminary release for evaluation, Subject to be changed without Notice

802.11g Wireless LAN+BT SiP combo Module V2.2

4.3.3.3. I/O READ/WRITE TIMING SPECIFICATION

CompactFlash I/O Output Write Timing Diagram

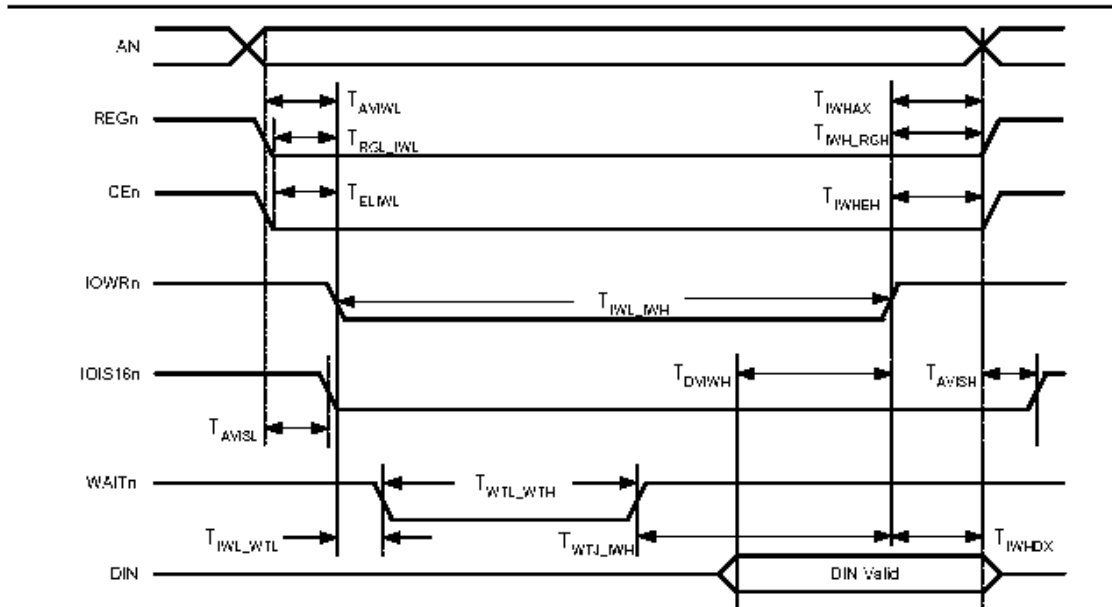

CompactFlash I/O Output Write Timing Data

Over full range of values specified in the Recommended Operating Conditions unless otherwise specified.

Symbol	Parameter	Condition	Min	Typ	Max	Units
T_{DVIWH}	Data Setup Time Before IOWR		60	--	--	ns
T_{IWHDX}	Data Hold Following IOWR		30	--	--	ns
T_{IWL_IWH}	IOWR Width Time		165	--	--	ns
T_{AVIWL}	Address Setup Before IOWR		70	--	--	ns
T_{IWHAX}	Address Hold Following IOWR		20	--	--	ns
T_{ELIWL}	CE Setup Before IOWR		5	--	--	ns
T_{IWHEH}	CE Hold Following IOWR		20	--	--	ns
T_{RGL_IWL}	REG Setup Before IOWR		5	--	--	ns
T_{IWH_RGH}	REG Hold Following IOWR		0	--	--	ns
T_{AVISL}	IOIS16 Delay Falling From Address		--	--	35	ns
T_{AVISH}	IOIS16 Delay Rising From Address		--	--	35	ns
T_{IWL_WTL}	Wait Delay Falling from IOWR		--	--	35	ns
T_{WTJ_IWH}	IOWR High from Wait High		0	--	--	ns
T_{WTL_WTH}	Wait Width Time		--	--	350	ns

All rights are reserved by USI. No part of this technical document can be reproduced in any form without permission of USI.

Preliminary release for evaluation, Subject to be changed without Notice

802.11g Wireless LAN+BT SiP combo Module V2.2

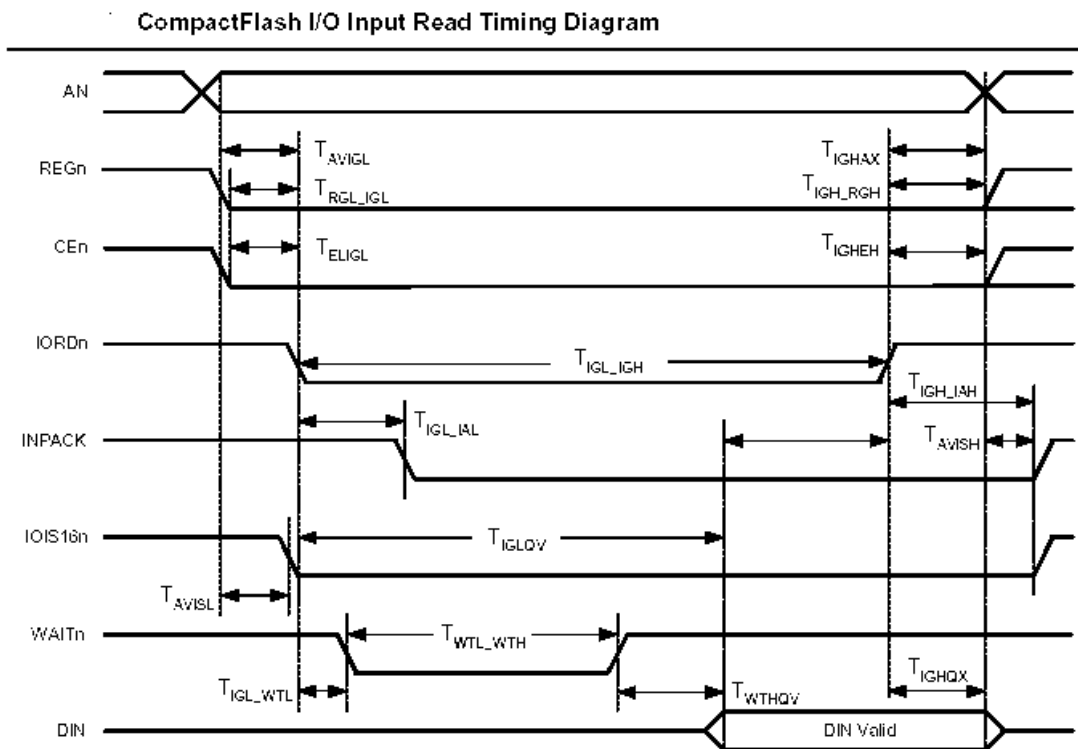

CompactFlash I/O Input Read Timing Data

Over full range of values specified in the Recommended Operating Conditions unless otherwise specified.

Symbol	Parameter	Condition	Min	Typ	Max	Units
T_{IGLQV}	Data Delay After IORD		--	--	100	ns
T_{IGHQX}	Data Hold Following IORD		0	--	--	ns
T_{IGL_IGH}	IORD Width Time		165	--	--	ns
T_{AVIGL}	Address Setup Before IORD		70	--	--	ns
T_{IGHAX}	Address Hold Following IORD		20	--	--	ns
T_{ELIGL}	CE Setup Before IORD		5	--	--	ns
T_{IGHEH}	CE Hold Following IORD		20	--	--	ns
T_{RGL_IGL}	REG Setup Before IORD		5	--	--	ns
T_{IGH_RGH}	REG Hold Following IORD		0	--	--	ns
T_{IGL_IAL}	INPACK Delay Falling from IORD		0	--	45	ns
T_{IGH_IAH}	INPACK Delay Rising from IORD		--	--	45	ns

4.4. WIRELESS SPECIFICATIONS

The WM-BG-MR-01 module comply with the following features and standards;

All rights are reserved by USI. No part of this technical document can be reproduced in any form without permission of USI.

Preliminary release for evaluation, Subject to be changed without Notice

802.11g Wireless LAN+BT SiP combo Module V2.2

Features	Description
WLAN Standards	IEEE 802 Part 11G (802.11G)
Bluetooth	Bluetooth™ 1.1 and 1.2 compliance
Antenna Connector	Two antenna connectors support 802.11 and BT one for each.
Coexistence	Hardware signaling
Frequency Band	2.400 – 2.484 GHz

4.5. RADIO SPECIFICATIONS 802.11G

Features	Description
Frequency Band	2.4000 – 2.497 GHz (2.4 GHz ISM Band)
Number of selectable Sub channels	14 channels
Modulation	OFDM, DSSS (Direct Sequence Spread Spectrum), DBPSK, DQPSK, CCK , 16QAM, 64QAM
Supported rates	1,2, 5.5,11,6,9,12,24,36,48,54 Mbps
Maximum receive level	- 10dBm (with PER < 8%)
Output Power	15 dBm +/- 1 dBm 802.11b 13 dBm +/- 1 dBm 802.11g

Receive Sensitivity	Data Rate
-72 dBm	54Mbps
	48 Mbps
	36Mbps
	24Mbps
	18Mbps
	12Mbps
- 85 dBm	11 Mbps
	9 Mbps
	6 Mbps
- 89 dBm	5.5 Mbps
- 91 dBm	2.0 Mbps
- 93 dBm	1.0 Mbps

4.6. RADIO SPECIFICATIONS 802.15 BLUETOOTH

The Radio specification is compliant with the Bluetooth™ 1.1 and 1.2 class 2 specification

Features	Description
Frequency Band	2400 ~ 2483.5 MHz

All rights are reserved by USI. No part of this technical document can be reproduced in any form without permission of USI.

Preliminary release for evaluation, Subject to be changed without Notice

802.11g Wireless LAN+BT SiP combo Module V2.2

Number of Channels	79 channels
Modulation	FHSS (Frequency Hopping Spread Spectrum) , GFSK
Antenna Connector	One Hirose W.FL –R –SMT(10) RF connector

4.7. BLUETOOTH RADIO CHARACTERISTICS

Features	Description
Maximum Receive Level	3 dBm (Typical)
Output Power	1 dBm (Typical)
Sensitivity	-81 dbm @ 0.1% BER @ 25 ° Celsius (Typical)

All rights are reserved by USI. No part of this technical document can be reproduced in any form without permission of USI.

Preliminary release for evaluation, Subject to be changed without Notice

802.11g Wireless LAN+BT SiP combo Module V2.2

4.8. DIMENSIONS, WEIGHT AND MOUNTING

The following paragraphs provide the requirements for the size, weight and mounting of the WM-BG-MR-01 module.

4.8.1. DIMENSIONS

The size and thickness of the WM-BG-MR-01 module is listed below:

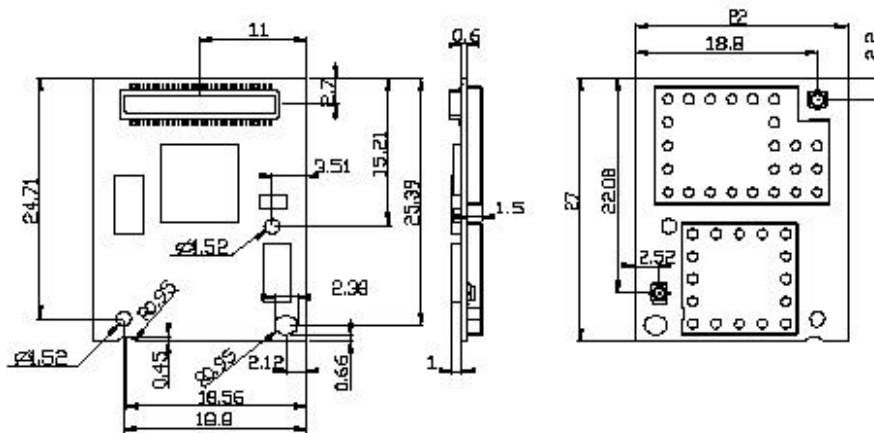

The height – will be finalized after the module design is frozen.

4.8.2. WEIGHT

Weight shall not exceed 10 gram including the shielding.

4.8.3. MOUNTING

The WM-BG-MR-01 module is B2B mounted type component. The B2B connector and additional screw hole provide mounting mechanism to secure the WM-BG-MR-01 module against vibration and shock on the host system.

4.9. SHOCK AND VIBRATION

All shock and vibration test will be performed by using an interface adapter card. Additional shock and vibration tests can be performed – on request – by using the real host being PDA, Textbook or any other application. The interface card will provide mounting facility base on the recommendation /application guide provided.

All rights are reserved by USI. No part of this technical document can be reproduced in any form without permission of USI.

Preliminary release for evaluation, Subject to be changed without Notice

802.11g Wireless LAN+BT SiP combo Module V2.2

Vibration

Operating	Frequency sweep from 3-150-3 Hz with a constant 0.25 G input
Non-Operational	Frequency sweep from 3-150-3 Hz with a constant 0.5 G input

Shock

Operational	25 G peak within 3.75 msec in normal base position
Non-Operational	65 G peak in 3.75 msec in normal base position. 30 G within 8 msec square or trapezoidal shock in + and - direction along the 3 axis. (Total 6 shocks)

Note: Above tests are executed without packaging material.

5. COMPATIBILITY AND INTEROPERABILITY

5.1. WI-FI LOGO

The product needs to be verified with Wi-Fi certification base on CF form factor to prove the hardware compatibility. For the other specific application, Wi-Fi certification is dependent on the capability and application of the host system.

5.2. WHQL COMPLIANCE

Not required for WM-BG-MR-01 module

6. CONFIGURABILITY

No user configuration needed. The CIS and MAC Address will be loaded during production of the WM-BG-MR-01 module.

7. SECURITY

The WM-BG-MR-01 module supports WEP64/128,WPA , AES-CCM which including TKIP (full version TKIP SSN /WPA) . Refer to Marvell Libertas solution.

8. OPERATING SYSTEM COMPATIBILITY

Drivers are supported for the following OS:

- Windows CE 3.0 /.NET , Win CE 5.0 (2005)
- Linux.
- Pocket PC 2003.2004

9. LEGAL, REGULATORY & OTHER TECHNICAL CONSTRAINTS

The WM-BG-MR-01 module is pre-tested to ensure that all requirements met as set forth in the following sections.

All rights are reserved by USI. No part of this technical document can be reproduced in any form without permission of USI.

Preliminary release for evaluation, Subject to be changed without Notice

802.11g Wireless LAN+BT SiP combo Module V2.2

Final certification (module certification) requires the antenna of targeted system with a lead-time of 6 weeks. The product deliverable shall be a pre-tested WM-BG-MR-01 module. No module level certification on WM-BG-MR-01 module.

9.1. EMC

The module will be pre-tested to ensure that we can certify the product in the following countries when final certification will be performed on products and or platforms.

- US. FCC CFR47 Part 15-B, Class B
- Canada. CSA C22.2, Class B
- Europe. 89/336/EEC, EMC Directive, including CE Mark
- ETS300 826, EMC standard for 2.4GHz wideband transmission systems
- EN55022, Class B (Emissions)
EN50082-1 (Immunity)
EN61000-3-2 (Harmonic AC current emissions)
- Japan. VCCI Standard, Class 2 (Emissions)
- Korea (MIC)

9.2. PRODUCT SAFETY SPECIFICATION

The WM-BG-MR-01 module is tested and pass successfully the following criteria;

The testing is to assure the quality of safety requirement on module. Final certification will be conducted on system level.

- UL1950 /CSA C22.2.950
- EN60 950 (IEC 950)
- CB scheme certification from National certification body as listed in CB bulletin No. 96A.
-

9.3. COMPONENT SPECIFICATION

All components used in this device meet the following component approval requirements.

PRINTED WIRING BOARDS: The printed wiring boards shall be Underwriters Laboratories Inc. "Recognized Component" (ZPMV2) under the category for Printed Wiring Boards, and shall be flammability rated 94V-1 or less flammable. The board material shall be rated 130°C minimum.

CONNECTORS: Any connectors, if used, shall be Underwriters Laboratories, Inc. "Recognized" (ECBT2/RTRT2) in accordance with the requirements in the UL Standard for Safety, UL 498. Any polymeric connector housing shall be molded of plastics rated UL 94V-2 or less flammable when tested to UL 94.

All rights are reserved by USI. No part of this technical document can be reproduced in any form without permission of USI.

Preliminary release for evaluation, Subject to be changed without Notice

802.11g Wireless LAN+BT SiP combo Module V2.2

WIRING: Any wiring material, if used, shall be UL Recognized Component Appliance Wiring Material (AVLV2). Wire shall be minimum rated 30V, 105°C.

PLASTIC PARTS - Any plastic parts used shall be molded of plastics that are UL "Recognized" (QFMZ2) and rated UL 94V-2 or less flammable when tested to UL 94.

“PB FREE” - The entire component Suppliers has to support Green requirement base on USI's policy. All of the components which including process and materials has to be Lead Free.

9.4. RADIO REQUIREMENTS AND AP PROVALS

The WM-BG-MR-01 module is tested with adapter card to comply with following standard. The testing is to assure the performance of regulatory requirement on module. Final certification will be conducted on system level.

- US/CAN: FCC CFR47 Part 15.247
- Japan: TELEC
- Korea: MIC

All rights are reserved by USI. No part of this technical document can be reproduced in any form without permission of USI.

Preliminary release for evaluation, Subject to be changed without Notice

802.11g Wireless LAN+BT SiP combo Module V2.2

9.5. PRODUCT MARKING

The Module is marked by laser marking which containing the following information:

Description:	WM-BG-XX-XX
Serial number:	yyllwkxxxx
Revision:	format to follow USI revision level in PDM System

For the serial number the following format will be followed:

yy = last two digits of current year

// = Assembly Location:

UT = USI Taiwan

UM = USI Mexico

UC = USI China

wk = current week (week period = starting on Monday)

xxxx = consecutive number, starting at 0000 at beginning of each week.

9.6. ENVIRONMENTALLY SAFE MATERIAL RESTRICTIONS

The use of polychlorinated biphenyls (PCB's) is prohibited (specifically) as dielectric in capacitors or transformers.

Electrolytic capacitors shall not be composed of any quaternary salt ammonium and/or gamma-butyrolactone (***i.e. no el caps allowed***).

No CFC's (chlorofluorocarbons) shall be used anywhere in the manufacture of this product.

The use of tantalum capacitors should be minimized in any product of the product family [including the power-supply]. Where the use of tantalum caps cannot be avoided, provisions must be made in the manufacturing process to prevent reverse polarization.

The WM-BG-MR-01 module hardware design should take the safety of operation into consideration and prevent the potential risk on Labor safety for manufacturing process.

All rights are reserved by USI. No part of this technical document can be reproduced in any form without permission of USI.

Preliminary release for evaluation, Subject to be changed without Notice

802.11g Wireless LAN+BT SiP combo Module V2.2

10. FUNCTIONAL DESCRIPTION

The WM-BG-MR-01 module provides and interfaces between Compaq Flash or PC Card Interface, SDIO , SPI which suitable for wide range high-end processors or low cost ARM7 or other similar type of processors.

The core of the WM-BG-MR-01 module is the Marvell 88W83 Chipset solution.

The module is design base on the Marvell Libertas solution which contain the flip chip package MAC/BBP chip - 88W8385 , The transceiver 88W8015 low profile package IC to reduce the size of module. All the other components can be implement by all means to reach the mechanical specification.

A simplified block diagram of the WM-BG-MR-01 module is depicted in the Fig. below.

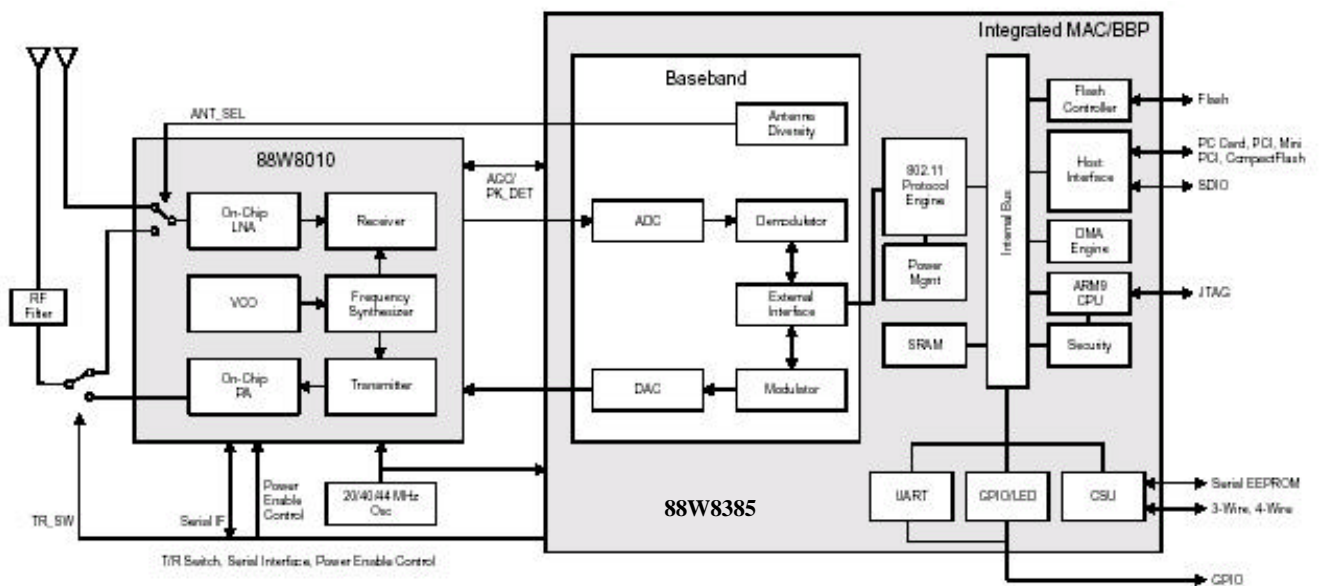

To be updated with BT

10.1. HARDWARE

The following sections provide the requirements for the different physical interfaces of the wireless module :

- Host Interface
- Antenna connections
- LED control signal
- Bluetooth WiFi coexistence control signals

All rights are reserved by USI. No part of this technical document can be reproduced in any form without permission of USI.

Preliminary release for evaluation, Subject to be changed without Notice

802.11g Wireless LAN+BT SiP combo Module V2.2

- Power
- GND

10.2. HOST INTERFACE

The host interface will be compatible with CompactFlash (PCMCIA) standard, 16 bit I/O bus. Signals which are not used won't be routed to the physical interface (connector). The host interface of Combo SiP Bluetooth portion is compliant with UART interface, the default baud rate setting is 115.2kbps and the optional range is from 9.6kbps to 921.6kbps.

On Board connector

Molex 53794-0608 or 55560-0607

[Socket, 60 pins, with positioning protection, stack height which is able to support 1.5 mm]



Datasheet_Molex_53
794-0608.pdf



Datasheet_Molex_55
560-0607.pdf

Host System:

Host System Connector

Molex 54722-0607

[Header, 60 pins, with positioning protection, stack height 1.5mm]



Datasheet_Molex_54
722-0607.pdf

Pin definition

[...] means optional function of the pin.

PD : Signal pull down internally in the chip by 50K ohm while initialization.

PU : Signal pull up internally in the chip by 100K ohm while initialization.

5VT : 5 Volt tolerance pin

xxx_B : Signal pins end with _B are "active high"

Pin Number	Definition	Draft Description		Type
WM-BG-MR-01	CF+ interface			
1	GND	GND	GND	
2	D03	HD3	Data Input/Output line constitute a bi-directional bus. HD15-01 are used to access the MODULE	O, PD, 5VT, 4mA

All rights are reserved by USI. No part of this technical document can be reproduced in any form without permission of USI.

Preliminary release for evaluation, Subject to be changed without Notice

802.11g Wireless LAN+BT SiP combo Module V2.2

			bus. HD[15:0] are used to access the MODULE MAC Host Interface register	Databus
3	D04	HD4	Data Input/Output line constitute a bi-directional bus. HD[15:0] are used to access the MODULE MAC Host Interface register	O, PD, 5VT, 4mA Databus
4	D05	HD5	Data Input/Output line constitute a bi-directional bus. HD[15:0] are used to access the MODULE MAC Host Interface register	IO, PD, 5VT, 4mA Databus
5	D06	HD6	Data Input/Output line constitute a bi-directional bus. HD[15:0] are used to access the MODULE MAC Host Interface register	IO, PD, 5VT, 4mA
6	D07	HD7	Data Input/Output line constitute a bi-directional bus. HD[15:0] are used to access the MODULE MAC Host Interface register	IO, PD, 5VT, 4mA
7	-CE_1	HCE1_B	Card Enable1 is driven by the host system and is used as select strobe in both I/O and memory mode. Enables even numbered address bytes.	Input, PU, 5VT
8	A10	A10	ADDRESS BUS lines driven by the host system which enables addressing of 0.5K address range within MAC. This address range is mainly used for accessing the CIS in Memory Mode. Signal HA0 is not used in word access mode. The pin is open in B2B module.	Input, PD,5VT
9	-OE	HOE_B	OUTPUT ENABLE is driven by the host during a memory Read Access.	Input, PU,5VT
10	A09	HA9	ADDRESS BUS lines driven by the host system which enables addressing of 0.5K address range within MAC. This address range is mainly used for accessing the CIS in Memory Mode. Signal HA0 is not used in word access mode.	Input, PD,5VT
11	A08	HA8	ADDRESS BUS lines driven by the host system which enables addressing of 0.5K address range within MAC. This address range is mainly used for accessing the CIS in Memory Mode. Signal HA0 is not used in word access mode.	Input, PD,5VT
12	A07	HA7	ADDRESS BUS lines driven by the host system which enables addressing of 0.5K address range within MAC. This address range is mainly used for accessing the CIS in Memory Mode. Signal HA0 is not used in word access mode.	Input, PD,5VT
13	VCC	VCC_WLAN	Power, 3.3V_WLAN	Input
14	A06	HA6	ADDRESS BUS lines driven by the host system which enables addressing of 0.5K address range within MAC. This address range is mainly used for accessing the CIS in Memory Mode. Signal HA0 is not used in word access mode.	Input, PD, 5VT
15	A05	HA5	ADDRESS BUS lines driven by the host system which enables addressing of 0.5K address range within MAC. This address range is mainly used for accessing the CIS in Memory Mode. Signal HA0 is not used in word access mode.	Input, PD, 5VT
16	A04	HA4	ADDRESS BUS lines driven by the host system which enables addressing of 0.5K address range	Input, PD, 5VT

All rights are reserved by USI. No part of this technical document can be reproduced in any form without permission of USI.

Preliminary release for evaluation, Subject to be changed without Notice

802.11g Wireless LAN+BT SiP combo Module V2.2

			within MAC. This address range is mainly used for accessing the CIS in Memory Mode. Signal HA0 is not used in word access mode.	
17	A03	HA3	ADDRESS BUS lines driven by the host system which enables addressing of 0.5K address range within MAC . This address range is mainly used for accessing the CIS in Memory Mode. Signal HA0 is not used in word access mode.	Input, PD, 5VT
18	A02	HA2	ADDRESS BUS lines driven by the host system which enables addressing of 0.5K address range within MAC. This address range is mainly used for accessing the CIS in Memory Mode. Signal HA0 is not used in word access mode.	Input, PD, 5VT
19	A01	HA1	ADDRESS BUS lines driven by the host system which enables addressing of 0.5K address range within MAC. This address range is mainly used for accessing the CIS in Memory Mode. Signal HA0 is not used in word access mode.	Input, PD, 5VT
20	A00	HA0	ADDRESS BUS lines driven by the host system which enables addressing of 0.5K address range within MAC. This address range is mainly used for accessing the CIS in Memory Mode. Signal HA0 is not used in word access mode.	Input, PD, 5VT
21	D00	HD0	Data Input/Output line constitute a bi-directional bus. HD[15:0] are used to access the MODULE MAC Host Interface register	IO, PD, 5VT, 4mA
22	D01	HD1	Data Input/Output line constitute a bi-directional bus. HD[15:0] are used to access the MODULE MAC Host Interface register	IO, PD, 5VT, 4mA
23	D02	HD2	Data Input/Output line constitute a bi-directional bus. HD[15:0] are used to access the MODULE MAC Host Interface register	IO, PD, 5VT, 4mA
24	-IOIS16	IOIS16_B	Output signal to indicate 16 bit IO operation. This signal is connected to ground at module side to indicate 16 bit IO..	GND
25	-CD2	CD2	Normal operation, this pin is functionally for card detection.	Out, 6mA, 5VT.
26	N/A	TXD_B	UART CMOS output data line	Output,WPU, 1μA
27	N/A	RTS_B	UART CMOS output signal, request to sent	Output ,WPU, 1μA
28	N/A	PCM_In	Reserved for BT portion , keep its open on host side if no use.	
29	N/A	VCC_WLAN	Power_WLAN	Input
30	GND	GND		
31	GND	GND		
32	D10	HD10	Data Input/Output line constitute a bi-directional bus. HD[15:0] are used to access the MODULE MAC Host Interface register	IO, PD, 5VT, 4mA
33	D09	HD9	Data Input/Output line constitute a bi-directional bus. HD[15:0] are used to access the MODULE MAC Host Interface register	IO, PD, 5VT, 4mA

All rights are reserved by USI. No part of this technical document can be reproduced in any form without permission of USI.

Preliminary release for evaluation, Subject to be changed without Notice

802.11g Wireless LAN+BT SiP combo Module V2.2

34	D08	HD8	Data Input/Output line constitute a bi-directional bus. HD[15:0] are used to access the MODULE MAC Host Interface register	IO, PD, 5VT, 4mA
35	-STSCHG	HSTSCHG_B	STATUS CHANGE indication to the host. This signal gets active when one of the bits in the PRR or CSR registers are set	Output, 4mA
36	-SPKR	PCM_Sync	Reserved for BT portion , keep its open on host side if no use.	
37	-REG	HREG_B	ATTRIBUTE MEMORY SELECT is driven by the host system and is used to access the Attribute Memory	Input, PU, 5VT
38	-INPACK	HINPACK_B	INPUT ACKNOWLEDGE is driven by MAC. Is asserted when the device is selected and the device is responding to an I/O Read command.	Output, 2mA
39	-WAIT	HWAIT_B	HWAIT_B is driven by MAC and allows for extending the memory or I/O cycle	Output, 4mA
40	RESET	HRESET	Used to asynchronously reset the complete Module	Input, PU,5VT
41	-VS2	VS2_B	Voltage sense signal	Output , 5VT 4mA
42	N/A	WLAN_LED_B	WLAN LED control signal, driven the LED indicating the link status of WLAN	Output, 4mA
43	N/A	PCM_OUT	Reserved for BT portion , keep its open on host side if no use.	
44	IREQ	IREQ_B	INTERRUPT REQUEST to the host. In Memory mode this pin signifies RDY/BSY_ typically used during card initialization immediately after reset or power on. Indicates to the host that the device is not able to transfer data	Output, 4mA
45	-WE	HWE_B	WRITE ENABLE is driven by the host during a memory Write Access	Input, PU,5VT
46	-IOWR	HLOWR_B	I/O Write Strobe is driven by the host and is asserted when the host wants to write to an on-chip I/O register	Input, PU,5VT
47	-IORD	HIORD_B	I/O Read Strobe is driven by the host and is asserted when the host wants to read from an on-chip I/O register	Input, PU,5VT
48	-VS1	-VS1	Reserved	Output , 5VT
49	-CE2	HCE2_B	CARD ENABLE2 is driven by the host system and is used as select strobe in both I/O and memory mode. Enables odd numbered address bytes	Input, PU,5VT
50	D15	HD15	Data Input/Output line constitute a bi-directional bus. HD[15:0] are used to access the MODULE MAC Host Interface register	IO, PD, 5VT, 4mA
51	D14	HD14	Data Input/Output line constitute a bi-directional bus. HD[15:0] are used to access the MODULE MAC Host Interface register	IO, PD, 5VT, 4mA
52	D13	HD13	Data Input/Output line constitute a bi-directional bus. HD[15:0] are used to access the MODULE MAC Host Interface register	IO, PD, 5VT, 4mA
53	D12	HD12	Data Input/Output line constitute a bi-directional bus. HD[15:0] are used to access the MODULE MAC Host Interface register	IO, PD, 5VT, 4mA

All rights are reserved by USI. No part of this technical document can be reproduced in any form without permission of USI.

Preliminary release for evaluation, Subject to be changed without Notice

802.11g Wireless LAN+BT SiP combo Module V2.2

54	D11	HD11	Data Input/Output line constitute a bi-directional bus. HD[15:0] are used to access the MODULE MAC Host Interface register	IO, PD, 5VT, 4mA
55	N/A	BT_LED_B	BT LED control signal which drive the LED to indicate the activity of Bluetooth	Output 4mA
56	N/A	RXD_B	UART data line CMOS input signal	Input, WPD, 1µA
57	N/A	CTS_B	UART clear to sent COMS input signal	Input, WPD, 1µA
58	N/A	PCM_CLK	Reserved for BT portion , keep its open on host side if no use.	
59	VCC	VCC_BT	Power 3.3V_BT	Input
60	GND	GND		

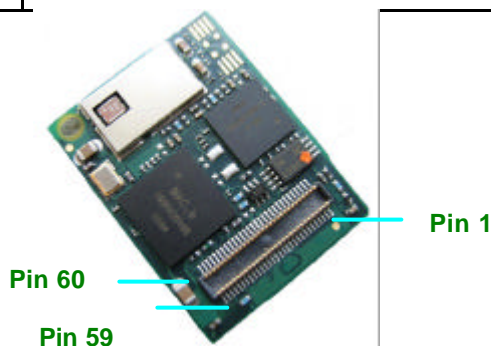

Fig 1: Pin 1 assignment and indication Drawing
(To be updated with latest design)

10.2.1. LED INTERFACE

The Wireless Module will provide two control signals to the host and capable to drive an LED to indicate the connectivity and operating status.

The WM-BG-MR-01 have 2 LED's (output) via 60 pins connector for feedback to the user on the current WLAN activity state. The signaling will reflect status / activity as described in the table below. Those two signals are provided via the board to board connector with the following pin assignment.

Pin No	Pin description	Function description
42	WLAN_LED	Link activity of Wireless LAN
55	BT	Power status indication

LED code to be defined !

10.2.2. ANTENNA INTERFACE

No antenna diversity supported on the Wireless Module.
The output impedance of the cable is 50 Ohms.

Antenna Connector: *Hirose W-FL-R-SMT(10)*

All rights are reserved by USI. No part of this technical document can be reproduced in any form without permission of USI.

Preliminary release for evaluation, Subject to be changed without Notice

802.11g Wireless LAN+BT SiP combo Module V2.2

10.2.3. BLUETOOTH INTERFACE

There are interfaces signal to routed between WiFi and Bluetooth to provide coexistence with 802.15 Bluetooth modules.

The BT co-existence interface supported, which is 2 Wire CSR co-existence.

The control signals are provided via the 60 pins B2B connector with the interface defined as below:

Symbol	Interface	“Signal name” & description
BTACT	2 Wire-CSR	“ BT_Priority ” This pin indicates to WLAN BCA device that BT module is active or will soon be active to TX/RX stage.
WLAN_active	2 Wire-CSR	“ Wlan_Active ”, This pin indicates to BT module that WLAN is active or will soon be active to TX/RX stage.

Note 1: “WLAN BCA” device is a functional block in 88W8385 works as Bluetooth co-existence management .

10.3. SOFTWARE

The following source code will be provided for porting to the embedded system under the SLA with chipset supplier

- Linux source code
- Source code of development utility base on Windows CE

11. DESIGN FOR EXCELLENCE (DFX)

11.1. TESTABILITY

The WM-BG-MR-01 module can be tested on the by using adapter card or similar interface. The adapter card must be such that from the FTS the WM-BG-MR-01 module is seen and recognized as PC Card or Compaq Flash.

- *No additional test pins are required to support in-circuit testing.*

11.2. LOGISTICS

All customer specific requirements – customization – will be implemented at the highest possible level to support build to order and keep the number of modules in SMT to a minimum. Additional module variants might be added base on business potential.

All rights are reserved by USI. No part of this technical document can be reproduced in any form without permission of USI.

Preliminary release for evaluation, Subject to be changed without Notice

802.11g Wireless LAN+BT SiP combo Module V2.2

12. HUMAN FACTORS

Due to the nature of this product (embedded module) no human factors required

13. INDUSTRIAL DESIGN

Due to the nature of this product (embedded module) no industrial design requirements are required.

14. RELIABILITY

The WM-BG-MR-01 module guarantee an MTBF of 150,000 hrs based on an ambient temperature and workload of 2,920 hours. The workload is based on a unit working for 8 hours per day, 365 days per year.

The MTBF estimation base on is Bell code standard, Class II.

15. PACKAGE

To be updated.

All rights are reserved by USI. No part of this technical document can be reproduced in any form without permission of USI.

Preliminary release for evaluation, Subject to be changed without Notice

802.11g Wireless LAN+BT SiP combo Module V2.2

Marvell is Trademark of 3'rd Party.

For Additional information, please contact the following:

Universal Scientific Industrial Co., Ltd.

Headquarters

141, Lane 351, Taiping Road, Sec. 1, Tsao-Tuen, Taiwan,

[Http://www.usi.com.tw](http://www.usi.com.tw)

Tel: + 886-49-2350876, 2325876

Fax: +886-49-3439561, 2337360,2351093

E-mail:usi@ms.usi.com.tw

All rights are reserved by USI. No part of this technical document can be reproduced in any form without permission of USI.

Preliminary release for evaluation, Subject to be changed without Notice