





FCC PART 15C
 IC RSS-210, ISSUE 8, DEC 2010
 TEST AND MEASUREMENT REPORT

For

Trimble Navigation Limited

935 Stewart Drive,
 Sunnyvale, CA 94085, USA

FCC ID: JUP-8262070
IC: 1756A-8262070

Report Type: Original Report	Product Type: SNR920-GPS Receiver with 900 MHz, 2.4 GHz FHSS & Wi-Fi Transceivers
Test Engineer: Jack Liu	
Report Number: R1103102-247	
Report Date: 2011-05-13	
Reviewed By: Victor Zhang EMC/RF Lead	
Prepared By: Bay Area Compliance Laboratories Corp. (84) 1274 Anvilwood Avenue, Sunnyvale, CA 94089, USA Tel: (408) 732-9162 Fax: (408) 732 9164	

Note: This test report is prepared for the customer shown above and for the device described herein. It may not be duplicated or used in part without prior written consent from Bay Area Compliance Laboratories Corp. This report **must not** be used by the customer to claim product certification, approval, or endorsement by NVLAP*, NIST, or any agency of the Federal Government.

* This report may contain data that are not covered by the NVLAP accreditation and are marked with an asterisk "*" ...

TABLE OF CONTENTS

1	GENERAL INFORMATION.....	5
1.1	PRODUCT DESCRIPTION FOR EQUIPMENT UNDER TEST (EUT).....	5
1.2	MECHANICAL DESCRIPTION OF EUT.....	5
1.3	OBJECTIVE.....	5
1.4	RELATED SUBMITTAL(S)/GRANT(S).....	5
1.5	TEST METHODOLOGY.....	5
1.6	MEASUREMENT UNCERTAINTY.....	5
1.7	TEST FACILITY.....	6
2	SYSTEM TEST CONFIGURATION.....	7
2.1	JUSTIFICATION.....	7
2.2	EUT EXERCISE SOFTWARE.....	7
2.3	SPECIAL ACCESSORIES.....	7
2.4	EQUIPMENT MODIFICATIONS.....	7
2.5	LOCAL SUPPORT EQUIPMENT.....	7
2.6	EUT INTERNAL CONFIGURATION.....	7
2.7	INTERFACE PORTS AND CABLING.....	8
3	SUMMARY OF TEST RESULTS.....	9
4	FCC §15.205, §15.209, §15.247(D) & IC RSS-210 §2.2, §A8.5 – RESTRICT BAND AND UNWANTED EMISSIONS.....	10
4.1	APPLICABLE STANDARD.....	10
4.2	TEST SETUP AND BLOCK DIAGRAM.....	11
4.3	TEST PROCEDURE.....	12
4.4	CORRECTED AMPLITUDE & MARGIN CALCULATION.....	12
4.5	TEST EQUIPMENT LIST AND DETAILS.....	12
4.6	TEST ENVIRONMENTAL CONDITIONS.....	13
4.7	SUMMARY OF TEST RESULTS.....	13
4.8	RADIATED EMISSIONS TEST RESULTS.....	14
5	IC RSS-GEN §4.10 & RSS-210 - §2.6 RECEIVER SPURIOUS EMISSIONS.....	16
5.1	APPLICABLE STANDARD.....	16
5.2	TEST SETUP AND BLOCK DIAGRAM.....	16
5.3	TEST PROCEDURE.....	17
5.4	CORRECTED AMPLITUDE & MARGIN CALCULATION.....	17
5.5	TEST EQUIPMENT LIST AND DETAILS.....	17
5.6	TEST ENVIRONMENTAL CONDITIONS.....	17
5.7	SUMMARY OF TEST RESULTS.....	18
6	FCC §15.247(I), §2.1091 & IC RSS-102 - RF EXPOSURE INFORMATION.....	20
6.1	APPLICABLE STANDARD.....	20
6.2	MPE PREDICTION.....	21
6.3	TEST RESULT.....	21
7	EXHIBIT A – FCC & IC LABELING REQUIREMENTS.....	22
7.1	FCC ID LABEL REQUIREMENTS.....	22
7.2	IC LABEL REQUIREMENTS.....	22
7.3	FCC ID & IC LABEL CONTENTS AND LOCATION.....	23
8	EXHIBIT B – TEST SETUP PHOTOGRAPHS.....	25
8.1	TX RADIATED EMISSIONS - FRONT VIEW.....	25

8.2	TX RADIATED EMISSIONS BELOW 1 GHZ - REAR VIEW	25
8.3	TX RADIATED EMISSIONS ABOVE 1 GHZ - REAR VIEW	26
8.4	RX RADIATED EMISSIONS - FRONT VIEW	26
8.5	RX RADIATED EMISSIONS - REAR VIEW	27
8.6	RX RADIATED EMISSIONS ABOVE 1 GHZ - REAR VIEW	27
9	EXHIBIT C- EUT PHOTOGRAPHS.....	28
9.1	EUT TOP VIEW.....	28
9.2	EUT BOTTOM VIEW	28
9.3	EUT REAR VIEW	29
9.4	GPS ANTENNA WITH CABLE VIEW	29
9.5	EUT OPEN VIEW 1	30
9.6	EUT OPEN VIEW 2	30
9.7	EUT OPEN VIEW 3	31
9.8	EUT OPEN VIEW 4	31
9.9	MAIN BOARD TOP VIEW.....	32
9.10	MAIN BOARD BOTTOM VIEW	32
9.11	2.4 GHZ RADIO BOARD FRONT VIEW.....	33
9.12	2.4 GHZ RADIO BOARD REAR VIEW.....	33
9.13	2.4 GHZ MODULE BOARD FRONT VIEW WITH SHIELDING.....	34
9.14	2.4 GHZ MODULE BOARD REAR VIEW WITH SHIELDING.....	34
9.15	2.4 GHZ MODULE BOARD FRONT VIEW WITHOUT SHIELDING	35
9.16	2.4 GHZ MODULE BOARD FRONT VIEW WITHOUT SHIELDING	35
9.17	2.4 GHZ WI-FI MODULE FRONT VIEW	36
9.18	2.4 GHZ WI-FI MODULE REAR VIEW	36
9.19	900 MHZ MODULE FRONT VIEW WITH SHIELDING.....	37
9.20	900 MHZ MODULE FRONT VIEW WITHOUT SHIELDING	37
9.21	900 MHZ MODULE REAR VIEW.....	38

DOCUMENT REVISION HISTORY

Revision Number	Report Number	Description of Revision	Date of Revision
0	R1103102-247	Original Report	2011-05-13

1 General Information

1.1 Product Description for Equipment under Test (EUT)

This test and measurement report was prepared on behalf of *Trimble Navigation Limited* and their product model: *SNR920, + 2.4 GHz, Wi-Fi* (P/N 0261J005SQ), or the EUT as it is referred to in this report. The EUT integrates a 900 MHz FHSS, 2.4 GHz FHSS radio (FCC ID: F4AWLNG1, IC: 3913A-WLNG1), a 2.4 GHz Wi-Fi radio (FCC ID: HSW-2410G, IC: 4492A-2410G), a Copernicus GPS radio, Ethernet functionality, Serial and CAN ports, and are powered via the vehicle's battery.

1.2 Mechanical Description of EUT

The EUT measures approximately 22cm L x 21.5cm W x 6cm H and weighs 2.35 kg.

The data gathered are from a production sample provided by the manufacturer, serial number: 0201J0068Q

1.3 Objective

This report is prepared on behalf of *Trimble Navigation*, in accordance with Part 2, Subpart J, and Part 15, Subparts B and C of the Federal Communication Commissions rules and IC RSS-210 Issue 8, December 2010.

The objective is to determine compliance with FCC rules for Output Power, Antenna Requirements, 6 dB Bandwidth, and power spectral density, 100 kHz Bandwidth of Band Edges Measurement, Spurious Emissions, Conducted and Radiated Spurious Emissions.

1.4 Related Submittal(s)/Grant(s)

Conducted testing results please refer to FCC ID: JUP-6734890, IC: 1756A-6734890, report number: R1002232-247.

1.5 Test Methodology

All measurements contained in this report were conducted in accordance with ANSI C63.4-2003.

1.6 Measurement Uncertainty

All measurements involve certain levels of uncertainties, especially in field of EMC. The factors contributing to uncertainties are spectrum analyzer, cable loss, antenna factor calibration, antenna directivity, antenna factor variation with height, antenna phase center variation, antenna factor frequency interpolation, measurement distance variation, site imperfections, mismatch (average), and system repeatability.

Based on NIS 81, The Treatment of Uncertainty in EMC Measurements, the values range from ± 2.0 for Conducted Emissions tests and ± 4.0 dB for Radiated Emissions tests are the most accurate estimates pertaining to uncertainty of EMC measurements at BACL.

Detailed instrumentation measurement uncertainties can be found in BACL report QAP-018.

1.7 Test Facility

The semi-anechoic chambers used by BACL to collect radiated and conducted emissions measurement data is located in the building at it's facility in Sunnyvale, California, USA.

BACL's test sites have been fully described in reports submitted to the Federal Communication Commission (FCC) and Voluntary Control Council for Interference (VCCI). The details of these reports have been found to be in compliance with the requirements of Section 2.948 of the FCC Rules on February 11 and December 10, 1997 and Article 8 of the VCCI regulations on December 25, 1997. The facility complies with the radiated and AC line conducted test site criteria set forth in ANSI C63.4-2003.

The Federal Communications Commission and Voluntary Control Council for Interference has the reports on file and is listed under FCC registration number: 90464 and VCCI Registration No.: C-2698 and R-2463. The test site has been approved by the FCC and VCCI for public use and is listed in the FCC Public Access Link (PAL) database.

Additionally, BACL is a National Institute of Standards and Technology (NIST) accredited laboratory, under the National Voluntary Laboratory Accredited Program (Lab Code 200167-0). The current scope of accreditations can be found at <http://ts.nist.gov/ts/htdocs/210/214/scopes/2001670.htm>

2 System Test Configuration

2.1 Justification

The system was configured for testing in accordance with ANSI C63.4-2003.
The EUT was tested in the testing mode to represent *worst*-case results during the final qualification test.

2.2 EUT Exercise Software

The software to exercise the unit was provided by the client. It is Commset.

2.3 Special Accessories

N/A.

2.4 Equipment Modifications

No modifications were made to the EUT.

2.5 Local Support Equipment

Manufacturers	Descriptions	Models	Serial Numbers
-	DC Power Supply	-	-
Dell	Laptop	Dell D620	17899297525
Dell	Laptop	Dell D620	35990178337
Trimble	SNR420/920 (Base)	-	-

2.6 EUT Internal Configuration

Manufacturers	Descriptions	Models	Serial Numbers
Trimble Navigation Limited	Main Board	SNRx20	-
Trimble	900 MHz Radio module (Tx/Rx)	53195-00-F	2121045012
Quatech Inc	WiFi module	WLNG-ET-DP501 FCC ID: F4AWLNG1	00086824043A
Cirronet	2.4GHz radio module	RFM WIT2410M4G FCC ID: HSW-2410G	-

2.7 Interface Ports and Cabling

Cable Description	Length (m)	From	To
TNC cable	> 2	EUT	GPS Antenna
BNC	> 2	EUT	Base
Trimble 82725-00 Rev test cable	> 2	EUT	Laptop

3 Summary of Test Results

FCC 15C & IC RSS-210 Rules	Description of Test	Results
FCC §15.203 IC RSS-Gen §7.1.4	Antenna Requirements	Note ¹
FCC §15.207 (a) IC RSS-Gen §7.2.2	AC Line Conducted Emissions	N/A*
FCC §15.205, §15.209 & §15.247(d) IC RSS-210 §2.2, §A8.5	Restricted Band and Unwanted Emissions	Compliant
FCC §2.1051 & 15.247(d) IC RSS-210 §A8.5 & RSS-Gen §7.2	Spurious Emissions at Antenna Port	Note ¹
FCC§15.247 (a)(1) IC RSS-210 §A8.1 (a)	20 dB Bandwidth & 99% Bandwidth	Note ¹
FCC§15.247 (a)(1) IC RSS-210 §A8.1(d)	Hopping Channel Separation	Note ¹
FCC§15.247 (a)(1)(iii) IC RSS-210 §A8.1(d)	Number of Hopping Frequencies Used	Note ¹
FCC§15.247 (a)(1)(iii) IC RSS-210 §A8.1(d)	Dwell Time	Note ¹
FCC§15.247 (b)(3) IC RSS-210 §A8.4(b)	Maximum Peak Output Power	Note ¹
FCC§ 15.247 (d) IC RSS-210 §A8.5	100 kHz Bandwidth of Frequency Band Edge	Note ¹
IC RSS-Gen §4.10	Receiver Spurious Emissions	Compliant
FCC §15.247(i) & §2.1091 IC RSS-Gen §5.5 & RSS-102	RF Exposure Information	Compliant

Note ¹: Refer to FCC ID: JUP-6734890, IC: 1756A-6734890, report number: R1002232-247.

N/A*: EUT is battery operation.

4 FCC §15.205, §15.209, §15.247(D) & IC RSS-210 §2.2, §A8.5 – Restrict Band and Unwanted Emissions

4.1 Applicable Standard:

As per FCC §15.205 and IC RSS-210 §2.2, Restricted bands of operation

(a) Except as shown in FCC §15.205 paragraphs (d), only spurious emissions are permitted in any of the frequency bands listed below:

MHz	MHz	MHz	MHz	MHz	GHz	GHz
0.090 – 0.110	8.291 – 8.294	16.69475 – 16.69525	156.7 – 156.9	1435 – 1626.5	3.332 – 3.339	10.6 – 12.7
0.495 – 0.505	8.362 – 8.366	25.5 – 25.67	162.0125 – 167.17	1645.5 – 1646.5	3.3458 – 3.358	13.25 – 13.4
2.1735 – 2.1905	8.37625 – 8.38675	37.5 – 38.25	167.72 – 173.2	1660 – 1710	3.600 – 4.400	14.47 – 14.5
4.125 – 4.128	8.41425 – 8.41475	73 – 74.6	240 – 285	1718.8 – 1722.2	4.5 – 5.15	15.35 – 16.2
4.17725 – 4.17775	12.29 – 12.293	74.8 – 75.2	322 – 335.4	2200 – 2300	5.35 – 5.46	17.7 – 21.4
4.20725 – 4.20775	12.51975 – 12.52025	108 – 121.94	399.9 – 410	2310 – 2390	7.25 – 7.75	22.01 – 23.12
6.215 – 6.218	12.57675 – 12.57725	123 – 138	608 – 614	2483.5 – 2500	8.025 – 8.5	23.6 – 24.0
6.26775 – 6.26825	13.36 – 13.41	149.9 – 150.05	960 – 1240	2690 – 2900	9.0 – 9.2	31.2 – 31.8
6.31175 – 6.31225	16.42 – 16.423	156.52475 – 156.52525	1300 – 1427	3260 – 3267	9.3 – 9.5	36.43 – 36.5
						Above 38.6

(b) Except as provided in 15.205 paragraphs (d) and (e), the field strength of emissions appearing within these frequency bands shall not exceed the limits shown in Section 15.209. At frequencies equal to or less than 1000 MHz, compliance with the limits in Section 15.209 shall be demonstrated using measurement instrumentation employing a CISPR quasi-peak detector. Above 1000 MHz, compliance with the emission limits in Section 15.209 shall be demonstrated based on the average value of the measured emissions. The provisions in Section 15.35 apply to these measurements.

(c) Except as provided in paragraphs (d) and (e), regardless of the field strength limits specified elsewhere in this Subpart, the provisions of this Section apply to emissions from any intentional radiator.

As per FCC §15.209 Radiated emission limits, general requirements.

(a) Except as provided elsewhere in this Subpart, the emissions from an intentional radiator shall not exceed the field strength levels specified in the following table:

Frequency (MHz)	Field Strength (microvolts/meter)	Measurement Distance (meters)
0.009 - 0.490	2400/F(kHz)	300
0.490 - 1.705	24000/F(kHz)	30
1.705 - 30.0	30	30
30 - 88	100 **	3
88 - 216	150 **	3
216 - 960	200 **	3
Above 960	500	3

** Except as provided in paragraph (g), fundamental emissions from intentional radiators operating under this Section shall not be located in the frequency bands 54-72 MHz, 76-88 MHz, 174-216 MHz or 470-806 MHz. However, operation within these frequency bands is permitted under other sections of this Part, e.g., Sections 15.231 and 15.241.

According to FCC §15.247(d), in any 100 kHz bandwidth outside the frequency bands in which the spread spectrum intentional radiator is operating, the radio frequency power that is produced by the intentional radiator shall be at least 20 dB below that in the 100 kHz bandwidth within the band that contains the highest level of the desired power, based on either an RF conducted or a radiated measurement. In addition, radiated emissions which fall in the restricted bands, as defined in §15.205(a), must also comply with the radiated emissions limits specified in §15.209(a) see §15.205(c).

IC RSS-210 §A8.5, In any 100 kHz bandwidth outside the frequency band in which the spread spectrum or digitally modulated device is operating, the radio frequency power that is produced shall be at least 20 dB below that in the 100 kHz bandwidth within the band that contains the highest level of the desired power, based on either an RF conducted or a radiated measurement, provided the transmitter demonstrates compliance with the peak conducted power limits. If the transmitter complies with the conducted power limits based on the use of RMS averaging over a time interval, as permitted under Section A8.4(4), the attenuation required shall be 30 dB instead of 20 dB. Attenuation below the general limits specified in Tables 2 and 3 is not required.

4.2 Test Setup and Block Diagram

The radiated emissions tests were performed in the 3-meter semi-anechoic chamber test site, using the setup in accordance with ANSI C63.4-2003. The specification used was the FCC 15C & IC RSS-210 limits.

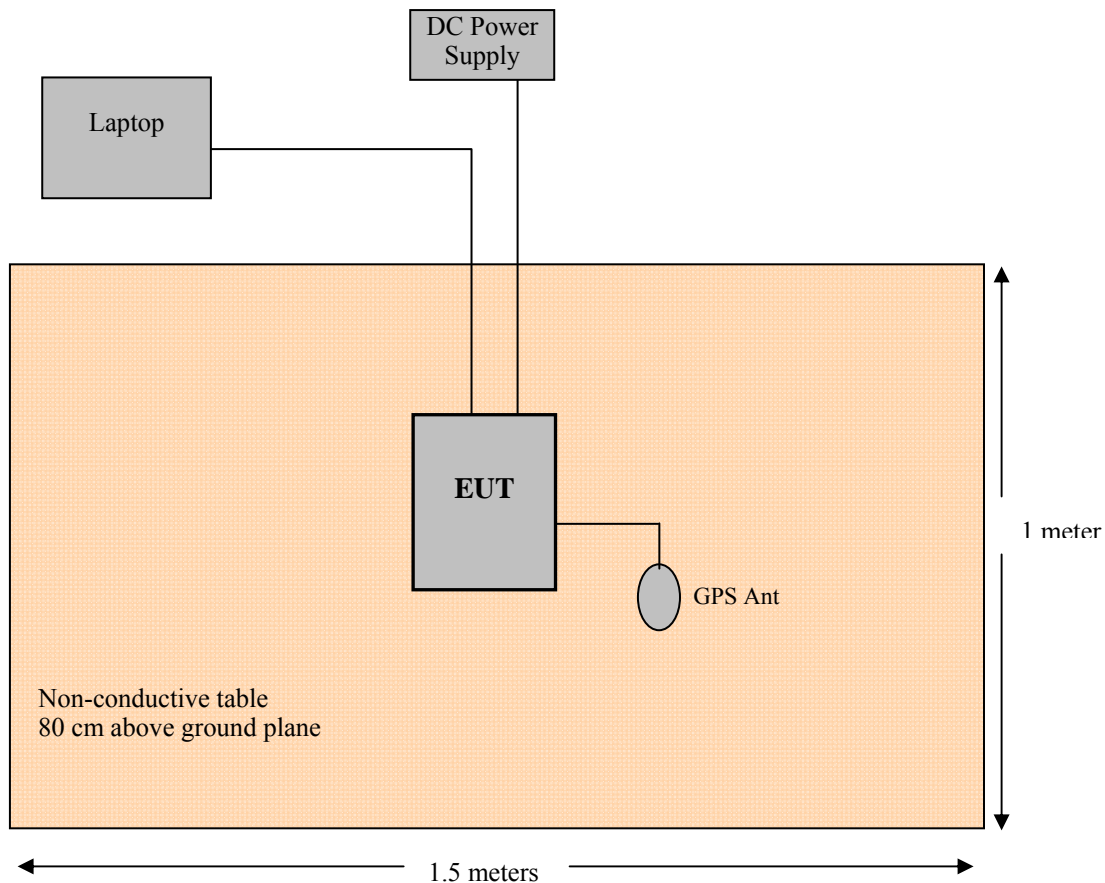

4.3 Test Procedure

For the radiated emissions test, the EUT, and all support equipment power cords was connected to the AC floor outlet.

The EUT is set 3 meter away from the testing antenna, which is varied from 1-4 mete, and the EUT is placed on a turntable, which is 0.8 meter above ground plane, the table shall be rotated for 360 degrees to find out the highest emission. The receiving antenna should be changed the polarization both of horizontal and vertical. Maximizing procedure was performed on the highest emissions to ensure that the EUT complied with all installation combinations.

The spectrum analyzer or receiver is set as:

Below 1000 MHz:

$$\text{RBW} = 100 \text{ kHz/VBW} = 300 \text{ kHz/Sweep} = \text{Auto}$$

Above 1000 MHz:

$$\begin{aligned} \text{Peak: RBW} &= 1\text{MHz/VBW} = 1\text{MHz/Sweep} = \text{Auto} \\ \text{Average: RBW} &= 1\text{MHz/VBW} = 10\text{Hz/Sweep} = \text{Auto} \end{aligned}$$

4.4 Corrected Amplitude & Margin Calculation

The Corrected Amplitude is calculated by adding the Antenna Factor and Cable Factor, and subtracting the Amplifier Gain from the Amplitude reading. The basic equation is as follows:

$$\text{Corrected Amplitude} = \text{Indicated Reading} + \text{Antenna Factor} + \text{Cable Factor} - \text{Amplifier Gain}$$

The “**Margin**” column of the following data tables indicates the degree of compliance with the applicable limit. For example, a margin of -7 dB means the emissions are 7 dB below the maximum limit. The equation for margin calculation is as follows:

$$\text{Margin} = \text{Corrected Amplitude} - \text{Limit}$$

4.5 Test Equipment List and Details

Manufacturer	Description	Model	Serial Number	Calibration Date
Agilent	PSA Spectrum Analyzer	E4440A	US45303156	2010-08-09
Rohde & Schwarz	EMI Test Receiver	ESCI 1166.5950K03	100337	2010-03-24
Sunol Science Corp	System Controller	SC99V	122303-1	N/R
Sunol Science Corp	Combination Antenna	JB3	A0020106-3	2010-06-16
Hewlett Packard	Pre amplifier	8447D	2944A06639	2010-06-18
A.R.A Inc	Horn antenna	DRG-1181A	1132	2010-11-29
Mini-Circuits	Pre Amplifier	ZVA-183-S	570400946	2010-05-12

* **Statement of Traceability: BACL Corp.** attests that all calibrations have been performed per the NVLAP requirements, traceable to the NIST.

4.6 Test Environmental Conditions

Temperature:	19~23° C
Relative Humidity:	35~44%
ATM Pressure:	101.4~102.1kPa

Testing was performed by Jack Liu on 2011-03-14~2011-03-24.

4.7 Summary of Test Results

According to the data hereinafter, the EUT complied with the FCC Part 15C & IC RSS-210 emissions limits, and had the worst margin of:

Mode: Transmitting			
Margin (dB)	Frequency (MHz)	Polarization (Horizontal/Vertical)	Channel, Range
30-1000 MHz			
-1.52	942.0625	Vertical	Middle, 30-1000 MHz
Above 1 GHz			
-	-	-	Low, 1-25 GHz
-	-	-	Mid, 1-25 GHz
-	-	-	High, 1-25 GHz

Note: All restricted band emissions were on the noise floor level and/or 20 dB below the limit.

Please refer to the following tables for specific test result details

4.8 Radiated Emissions Test Results

1) 30 – 1000 MHz measured at 3 meters

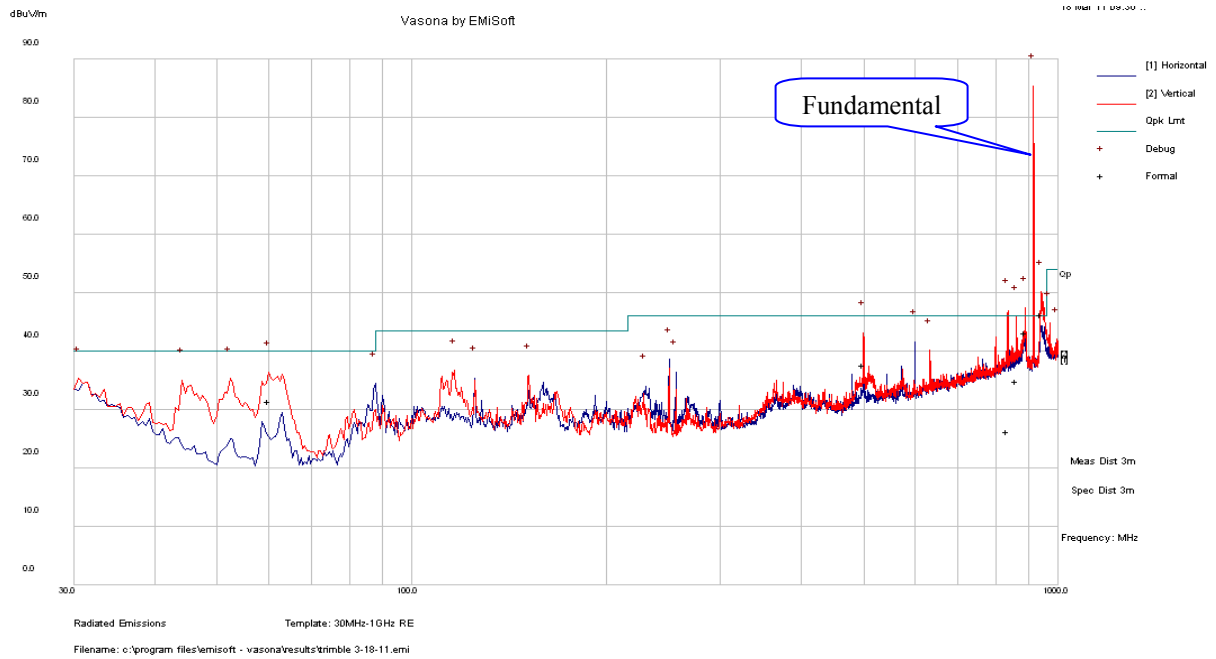

Frequency (MHz)	Corrected Amplitude (dB μ V/m)	Antenna Height (cm)	Antenna Polarity (H/V)	Turntable Azimuth (degrees)	Limit (dB μ V/m)	Margin (dB)
942.0625	48.48	111	V	335	46	-1.52
888.6883	43.22	165	V	360	46	-2.78
499.523	37.69	100	V	360	46	-8.31
60.208	31.42	121	V	360	40	-8.58
862.0168	34.96	167	V	360	46	-11.04
835.742	26.24	281	V	360	46	-19.76

2) 1-25 GHz measured at 3 meters

Frequency (MHz)	S.A. Reading (dBµV)	Azimuth (degrees)	Test Antenna			Cable Loss (dB)	Pre-Amp. (dB)	Cord. Amp. (dBµV/m)	FCC/IC		Comments
			Height (cm)	Polarity (H/V)	Factor (dB/m)				Limit (dBµV/m)	Margin (dB)	
Low Channel											
-	-	-	-	-	-	-	-	-	-	-	-
Middle Channel											
-	-	-	-	-	-	-	-	-	-	-	-
High Channel											
-	-	-	-	-	-	-	-	-	-	-	-

Note: All restricted band emissions were on the noise floor level and/or 20 dB below the limit.

5 IC RSS-Gen §4.10 & RSS-210 - §2.6 Receiver Spurious Emissions

5.1 Applicable Standard

IC RSS-Gen §4.10 & RSS-210 §2.6.

General Field Strength Limits for Transmitters and Receivers at Frequencies above 30 MHz

Frequency (MHz)	Field Strength microvolts/m at 3 meters (watts, e.i.r.p.)	
	Transmitters	Receivers
30 - 88	100 (3 nW)	100 (3 nW)
88 - 216	150 (6.8 nW)	150 (6.8 nW)
216 - 960	200 (12 nW)	200 (12 nW)
Above 960	500 (75 nW)	500 (75 nW)

5.2 Test Setup and Block Diagram

The radiated emissions tests were performed in the 3 meter chamber, using the setup in accordance with ANSI C63.4-2003.

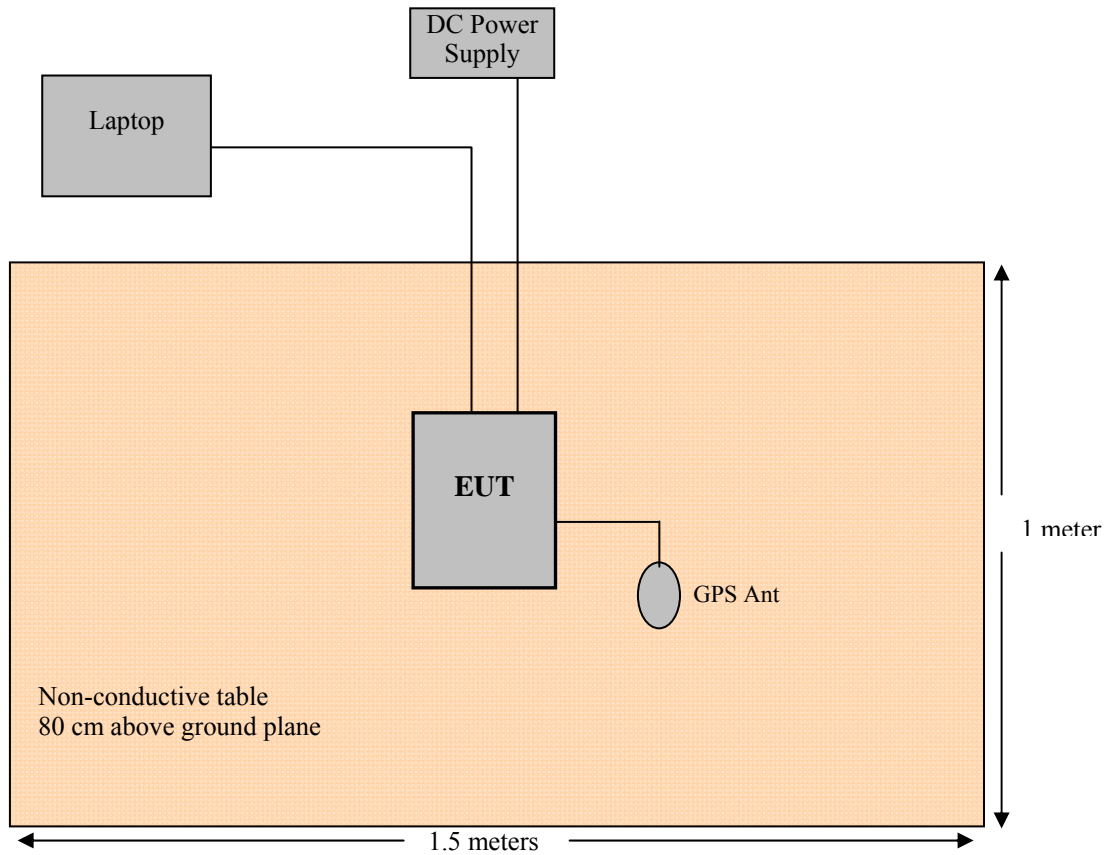

5.3 Test Procedure

Maximizing procedure was performed on the six (6) highest emissions to ensure EUT compliance is with all installation combinations.

All data were recorded in the peak detection mode. Quasi-peak readings was performed only when an emissions was found to be marginal (within -4 dB of specification limits), and are distinguished with a "QP" in the data table.

5.4 Corrected Amplitude & Margin Calculation

The Corrected Amplitude is calculated by adding the Antenna Factor and Cable Factor, and subtracting the Amplifier Gain from the Amplitude reading. The basic equation is as follows:

$$\text{Corrected Amplitude} = \text{Indicated Reading} + \text{Antenna Factor} + \text{Cable Factor} - \text{Amplifier Gain}$$

The "Margin" column of the following data tables indicates the degree of compliance with the applicable limit. For example, a margin of -7 dB means the emissions are 7 dB below the maximum limit. The equation for margin calculation is as follows:

$$\text{Margin} = \text{Corrected Amplitude} - \text{Limit}$$

5.5 Test Equipment List and Details

Manufacturer	Description	Model	Serial Number	Calibration Date
Agilent	PSA Spectrum Analyzer	E4440A	US45303156	2010-08-09
Rohde & Schwarz	EMI Test Receiver	ESCI 1166.5950K03	100337	2010-03-24
Sunol Science Corp	System Controller	SC99V	122303-1	N/R
Sunol Science Corp	Combination Antenna	JB3	A0020106-3	2010-06-16
Hewlett Packard	Pre amplifier	8447D	2944A06639	2010-06-18
A.R.A Inc	Horn antenna	DRG-1181A	1132	2010-11-29
Mini-Circuits	Pre Amplifier	ZVA-183-S	570400946	2010-05-12

* **Statement of Traceability:** BACL Corp. attests that all calibrations have been performed per the NVLAP requirements, traceable to the NIST.

5.6 Test Environmental Conditions

Temperature:	19~23° C
Relative Humidity:	35~44%
ATM Pressure:	101.4~102.1kPa

Testing was performed by Jack Liu on 2011-03-14~2011-03-24.

5.7 Summary of Test Results

According to the test data, the EUT complied with the with the applicable IC Standards, with the closest margins from the limit listed below:

Mode: Receiving			
Margin (dB)	Frequency (MHz)	Polarization (Horizontal/Vertical)	Channel, Range
30-1000 MHz			
-3.72	64.004	Vertical	Middle, 30-1000 MHz
Above 1 GHz			
-	-	-	1-10 GHz

Note: For above 1 GHz, all emissions were on the noise floor level and/or 20 dB below the limit.

1) 30-1000 MHz measured at 10 meters:

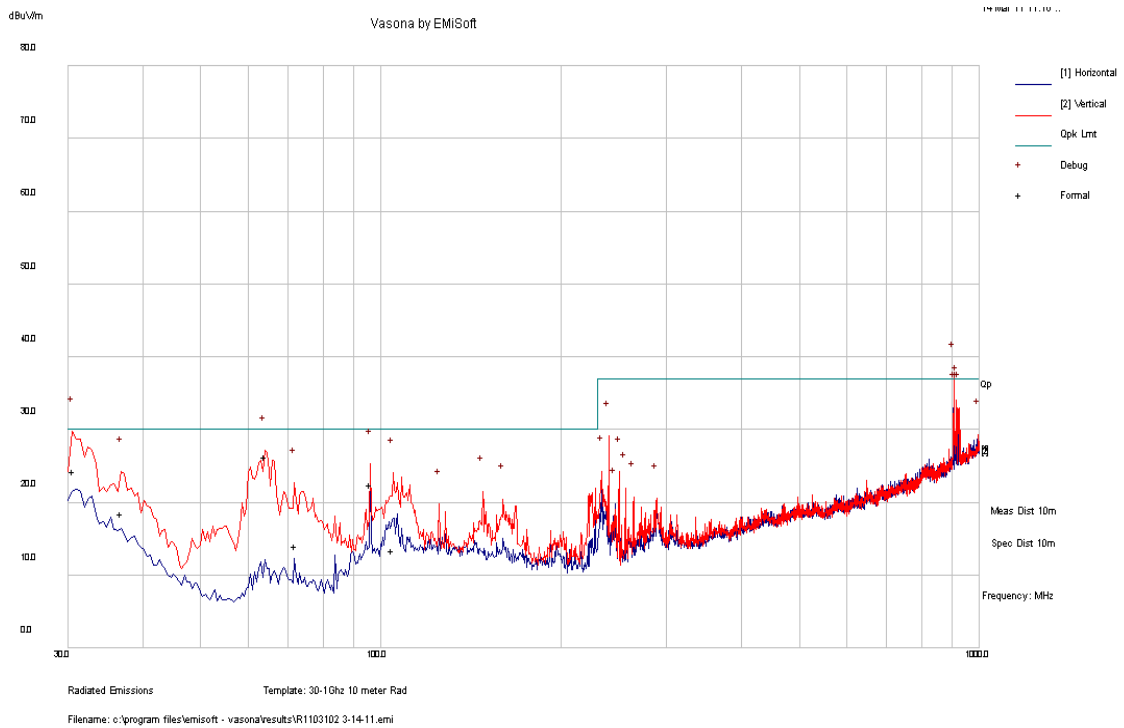

Frequency (MHz)	Corrected Amplitude (dBµV/m)	Antenna Height (cm)	Antenna Polarity (H/V)	Turntable Azimuth (degrees)	Limit (dBµV/m)	Margin (dB)
64.004	26.28	246	V	338	30	-3.72
30.661	24.31	99	V	240	30	-5.69
96.0485	22.49	174	V	284	30	-7.51
36.8665	18.54	98	V	291	30	-11.46
71.9495	14	120	V	92	30	-16.00
104.5548	13.48	228	V	282	30	-16.52

2) Above 1 GHz measured at 3 meters:

Frequency (MHz)	Corrected Amplitude (dBµV/m)	Antenna Height (cm)	Antenna Polarity (H/V)	Turntable Azimuth (degrees)	Limit (dBµV/m)	Margin (dB)
-	-	-	-	-	-	-

Note: All emissions were on the noise floor level and/or 20 dB below the limit.

6 FCC §15.247(i), §2.1091 & IC RSS-102 - RF Exposure Information

6.1 Applicable Standard

According to FCC §15.247(i) and §1.1307(b)(1), systems operating under the provisions of this section shall be operated in a manner that ensures that the public is not exposed to radio frequency energy level in excess of the Commission's guidelines.

According to §1.1310 and §2.1091 RF exposure is calculated.

Limits for General Population/Uncontrolled Exposure

Frequency Range (MHz)	Electric Field Strength (V/m)	Magnetic Field Strength (A/m)	Power Density (mW/cm ²)	Averaging Time (minutes)
Limits for General Population/Uncontrolled Exposure				
0.3-1.34	614	1.63	*(100)	30
1.34-30	824/f	2.19/f	*(180/f ²)	30
30-300	27.5	0.073	0.2	30
300-1500	/	/	f/1500	30
1500-100,000	/	/	1.0	30

f = frequency in MHz

* = Plane-wave equivalent power density

Before equipment certification is granted, the procedure of RSS-102 must be followed concerning the exposure of humans to RF fields.

According to IC RSS-102 Issue 2 section 4.1, RF limits used for general public will be applied to the EUT.

Frequency Range (MHz)	Electric Field (V/m rms)	Magnetic Field (A/m rms)	Power Density (W/m ²)	Averaging Time (Minutes)
0.003 - 1	280	2.19	-	6
1 - 10	280 / f	2.19 / f	-	6
10 - 30	28	2.19 / f	-	6
30 - 300	28	0.073	2*	6
300 - 1 500	1.585 f ^{0.5}	0.0042 f ^{0.5}	f / 150	6
1 500 - 15 000	61.4	0.163	10	6
15 000 - 150 000	61.4	0.163	10	616000 / f ^{1.2}
150 000- 300 000	0.158 f ^{0.5}	4.21 x 10 ⁻⁴ f ^{0.5}	6.67 x 10 ⁻⁵ f	616000 / f ^{1.2}

Note: f is frequency in MHz

* Power density limit is applicable at frequencies greater than 100 MHz

6.2 MPE Prediction

Predication of MPE limit at a given distance, Equation from OET Bulletin 65, Edition 97-01

$$S = PG/4\pi R^2$$

Where: S = power density

P = power input to antenna

G = power gain of the antenna in the direction of interest relative to an isotropic radiator

R = distance to the center of radiation of the antenna

<u>Maximum peak output power at antenna input terminal (dBm):</u>	<u>29.52</u>
<u>Maximum peak output power at antenna input terminal (mW):</u>	<u>895</u>
<u>Prediction distance (cm):</u>	<u>20</u>
<u>Prediction frequency (MHz):</u>	<u>902.7</u>
<u>Maximum Antenna Gain, typical (dBi):</u>	<u>0</u>
<u>Maximum Antenna Gain (numeric):</u>	<u>1</u>
<u>Power density of prediction frequency at 20.0 cm (mW/cm²):</u>	<u>0.178</u>
<u>Power density of prediction frequency at 20.0 cm (W/m²):</u>	<u>1.78</u>
<u>MPE limit for uncontrolled exposure at prediction frequency (mW/cm²):</u>	<u>0.602</u>
<u>MPE limit for uncontrolled exposure at prediction frequency (W/m²):</u>	<u>6.02</u>

Radio Type	Operating Frequency (MHz)	MPE Limit (mw/cm ²)	Conducted Power (mW)	Duty Cycle	Antenna Gain (dBi)	Gain (numeric)	Power Density at 20 cm	% of MPE	Co-located % of MPE
900 MHz Radio ON									
900 MHz Radio	902.7	0.602	895	100%	0.00	1.00	0.1781	29.6%	-
900 MHz Radio with 2.4 GHz FHSS Radio ON									
2.4 GHz FHSS Radio FCC ID: HSW-2410G	2469.81	1.000	69.02	70%	2.00	1.58	0.02	1.5%	31.1%
900 MHz Radio with 2.4 GHz Wi-Fi Radio ON									
2.4 GHz Wi-Fi Radio FCC ID: F4AWLNG1	2412	1.000	142.89	100%	3.00	2.00	0.06	5.7%	35.3%
900 MHz Radio with 2.4 GHz Wi-Fi Radio and 2.4 GHz FHSS Radio ON									
								-	36.8%

6.3 Test Result

The device complies with the MPE limit at 20 cm for uncontrolled exposure.