

FCC PART 15.247

INDUSTRY CANADA RSS-210, ISSUE 7, JUNE 2007



MEASUREMENT AND TEST REPORT

For

Trimble Navigation Limited

935 Stewart Drive, Sunnyvale, CA 94085, USA

Model: 64281-92
FCC ID: JUP-6248192
IC ID: 1756A-6248192

Report Type: <input checked="" type="checkbox"/> Original Report		Product Type: 900 MHz FHSS Radio Transceiver Module	
Test Engineer(s):	Choon Sian Ooi 		
Report Number:	R0711021		
Test Date(s)	2007-11-05, 2007-11-20, 2007-11-28		
Report Date:	2007-12-12		
Reviewed By:	Hans Mellberg, VP of Engineering 		
Prepared By: (24)	Bay Area Compliance Laboratories Corp. (BACL) 1274 Anvilwood Ave. Sunnyvale, CA 94089, USA Tel: (408) 732-9162 Fax: (408) 732-9164		

Note: This test report is for the customer shown above and their specific product only. It may not be duplicated or used in part without prior written consent from Bay Area Compliance Laboratories Corp. This report **must not** be used by the customer to claim product certification, approval, or endorsement by NVLAP, NIST, or any agency of the Federal Government

TABLE OF CONTENTS

1	GENERAL INFORMATION.....	5
1.1	PRODUCT DESCRIPTION FOR EQUIPMENT UNDER TEST (EUT).....	5
1.2	MECHANICAL DESCRIPTION OF EUT.....	5
1.3	EUT PHOTO.....	5
1.4	ANTENNA DESCRIPTION.....	6
1.5	OBJECTIVE.....	7
1.6	RELATED SUBMITTAL(S)/GRANT(S).....	7
1.7	TEST METHODOLOGY.....	7
1.8	MEASUREMENT UNCERTAINTY.....	7
1.9	TEST FACILITY.....	8
2	SYSTEM TEST CONFIGURATION.....	9
2.1	JUSTIFICATION.....	9
2.2	EUT EXERCISE SOFTWARE.....	9
2.3	SPECIAL ACCESSORIES.....	9
2.4	EQUIPMENT MODIFICATIONS.....	9
2.5	LOCAL SUPPORT EQUIPMENT LIST AND DETAILS.....	9
2.6	HOST SYSTEM DETAILS.....	9
2.7	HOST SYSTEM POWER SUPPLY INFORMATION.....	9
2.8	TEST SETUP BLOCK DIAGRAMS.....	10
3	SUMMARY OF TEST RESULTS.....	11
4	FCC §15.247 (i) and §2.1091, IC RSS-Gen 5.5 & RSS-102 - RF Exposure.....	12
4.1	APPLICABLE STANDARD.....	12
4.2	MPE PREDICTION.....	12
4.3	TEST RESULT.....	12
5	FCC §15.203, IC RSS-Gen §7.1.4 – Antenna Requirement.....	13
5.1	APPLICABLE STANDARD.....	13
5.2	RESULT.....	13
6	FCC §15.207 (a), IC RSS-Gen §7.2.2 - Conducted Emissions.....	17
6.1	APPLICABLE STANDARD.....	17
6.2	TEST SETUP.....	17
6.3	TEST EQUIPMENT LIST AND DETAILS.....	17
6.4	TEST PROCEDURE.....	18
6.5	SUMMARY OF TEST RESULTS.....	18
	HOT CONDUCTOR MODE.....	19
	QP MEASUREMENTS.....	19
	AVERAGE MEASUREMENTS.....	19
	NEUTRAL CONDUCTOR MODE.....	20
	QP MEASUREMENTS.....	20
	AVERAGE MEASUREMENTS.....	20
7	FCC §15.247(d), RSS-210 § A8.5 & RSS-Gen 7.2 - Spurious Emissions at Antenna Terminals.....	21
7.1	APPLICABLE STANDARD.....	21
7.2	MEASUREMENT PROCEDURE.....	21
7.3	TEST EQUIPMENT.....	21
7.4	TEST SETUP DIAGRAM.....	21
7.5	ENVIRONMENTAL CONDITIONS.....	22
7.6	MEASUREMENT RESULTS.....	22
8	FCC §15.205, §15.209 & §15.247(c), IC RSS-210 §A8.5 - Spurious Radiated Emissions.....	30
8.1	APPLICABLE STANDARD.....	30
8.2	TEST SETUP.....	31
8.3	EUT SETUP.....	31

8.4 TEST EQUIPMENT LIST AND DETAILS..... 32

8.5 TEST PROCEDURE 32

8.6 CORRECTED AMPLITUDE & MARGIN CALCULATION 32

8.7 ENVIRONMENTAL CONDITIONS 33

8.8 SUMMARY OF TEST RESULTS 33

8.9 RADIATED SPURIOUS EMISSIONS TEST DATA 34

9 RSS-210 § 2.6 Receiver Spurious Radiated Emissions43

9.1 TEST SETUP 43

9.2 EQUIPMENT LISTS AND DETAILS..... 43

9.3 ENVIRONMENTAL CONDITIONS 43

9.4 TEST PROCEDURE 43

9.5 CORRECTED AMPLITUDE & MARGIN CALCULATION 43

9.6 SUMMARY OF TEST RESULTS 44

10 FCC §15.247(a) (1), RSS-210 § A8.1(c) – 20 dB Bandwidth & 99% Bandwidth45

10.1 APPLICABLE STANDARD 45

10.2 MEASUREMENT PROCEDURE..... 45

10.3 EQUIPMENT LIST..... 45

10.4 ENVIRONMENTAL CONDITIONS 45

10.5 SUMMARY OF TEST RESULTS 46

11 §15.247 (a) (1) & RSS-210 §A8.1 (b) – Hopping Channel Separation.....48

11.1 APPLICABLE STANDARD 48

11.2 MEASUREMENT PROCEDURE..... 48

11.3 TEST EQUIPMENT 48

11.4 TEST SETUP DIAGRAM 48

11.5 ENVIRONMENTAL CONDITIONS 49

11.6 MEASUREMENT RESULTS..... 49

12 FCC §15.247(b) (2), RSS210 § A8.4 - Peak Output Power Measurement51

12.1 APPLICABLE STANDARD 51

12.2 MEASUREMENT PROCEDURE..... 51

12.3 EQUIPMENT LIST..... 51

12.4 ENVIRONMENTAL CONDITIONS 52

12.5 MEASUREMENT RESULT 52

13 §15.247(a)(1)(i) & RSS-210 § A8.1 (c) - Number of Hopping Frequencies Used.....54

13.1 STANDARD APPLICABLE 54

13.2 MEASUREMENT PROCEDURE..... 54

13.3 TEST EQUIPMENT LIST AND DETAILS..... 54

13.4 TEST SETUP DIAGRAM 54

13.5 ENVIRONMENTAL CONDITIONS 55

13.6 MEASUREMENT RESULT 55

14 §15.247(a) (1) (i), RSS-210 §A8.1 (c) - Dwell Time57

14.1 APPLICABLE STANDARD 57

14.2 MEASUREMENT PROCEDURE..... 57

14.3 TEST EQUIPMENT LIST AND DETAILS..... 57

14.4 TEST SETUP DIAGRAM 57

14.5 ENVIRONMENTAL CONDITIONS 58

14.6 MEASUREMENT RESULTS..... 58

15 FCC §15.247(d), RSS-210 § A8.5 - 100 kHz Bandwidth of Band Edges62

15.1 APPLICABLE STANDARD 62

15.2 MEASUREMENT PROCEDURE..... 62

15.3 EQUIPMENT LIST..... 62

15.4 ENVIRONMENTAL CONDITIONS 62

16 EXHIBIT A – FCC & IC EQUIPMENT LABELING REQUIREMENTS64

16.1 FCC § 2.925 IDENTIFICATION OF EQUIPMENT 64

16.2 FCC ID LABELING REQUIREMENTS AS PER FCC § 15.19 64

16.3 SPECIFICATIONS: AS PER RSS GEN 5.2 EQUIPMENT LABELING: 65

16.4 FCC ID & IC PRODUCT LABEL 65

16.5 SUGGESTED LABEL LOCATION (EUT TOP VIEW) 65

17 EXHIBIT B - TEST SETUP PHOTOGRAPHS66

17.1	CONDUCTED EMISSIONS – FRONT VIEW	66
17.2	CONDUCTED EMISSIONS – SIDE VIEW.....	66
17.3	RECEIVER RADIATED EMISSIONS – FRONT VIEW	67
17.4	RECEIVER RADIATED EMISSIONS – REAR VIEW.....	67
17.5	TRANSMITTER RADIATED SPURIOUS EMISSIONS – FRONT VIEW.....	68
17.6	TRANSMITTER RADIATED SPURIOUS EMISSIONS – REAR VIEW	68
18	EXHIBIT C - EUT PHOTOGRAPHS.....	69
18.1	EUT – TOP VIEW	69
18.2	EUT – BOTTOM VIEW.....	69
18.3	EUT PCB 1 (WITH RF SHIELDING)	70
18.4	EUT PCB 1 (WITHOUT RF SHIELDING).....	70
18.5	EUT PCB 2 (WITH RF SHIELDING)	71
18.6	EUT PCB 2 (WITHOUT RF SHIELDING).....	71
18.7	EUT EXTERNAL ANTENNA 1	72
18.8	EUT EXTERNAL ANTENNA 2	72
18.9	EUT EXTERNAL ANTENNA 3	73

1 GENERAL INFORMATION

1.1 Product Description for Equipment under Test (EUT)

The *Trimble Navigation Limited* product, *model: 62481-92* or the “EUT” as referred to in this report, is a 900 MHz FHSS Radio Transceiver Module.

The transceiver uses 50 channels for frequency hopping in the 902.0 to 928 MHz band. The lowest channel is centered at 902.621 MHz. The highest channel is centered at 927.88 MHz.

The transceiver uses BPSK modulation

1.2 Mechanical Description of EUT

The Trimble Navigation Limited product, *model: 62481-92* is a 900 MHz FHSS Radio Transceiver Module and measures approximately 17 cm (L) x 9 cm (W) x 5 cm (H), weighing approximately 400 g.

1.3 EUT Photo

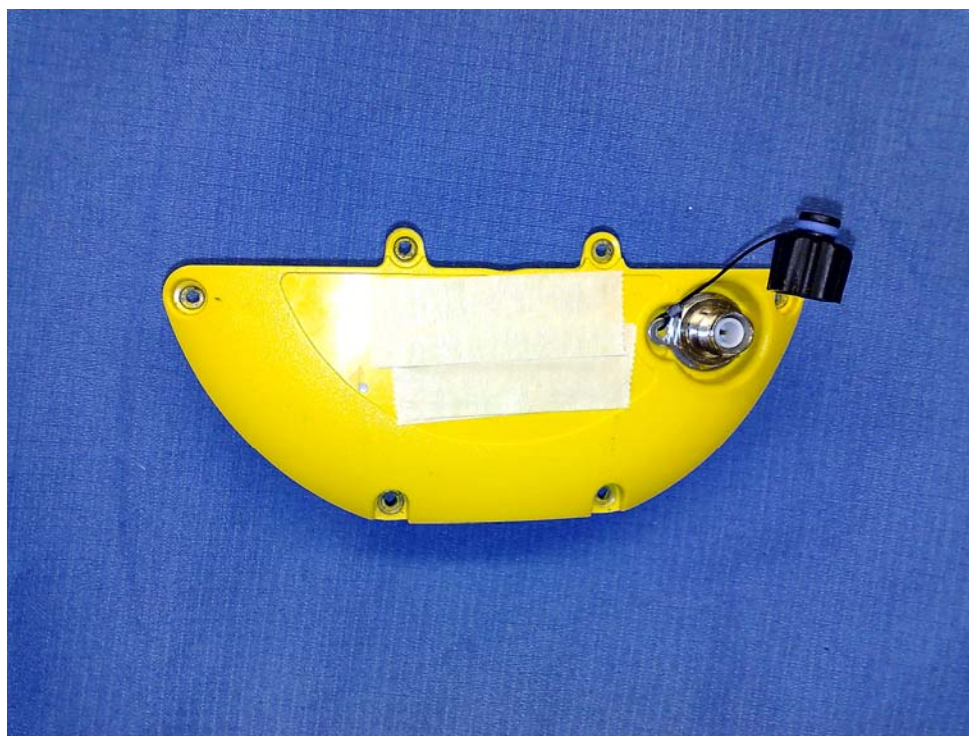

Please refer to Exhibit C for addition EUT photographs.

1.4 Antenna Description

Item Number	Model/Type	
External Antenna 1	Model number:	32318
	Antenna Manufacturer:	Trimble Navigation
	Frequency :	890-960 MHz
	Maximum Gain	3 dBi
	Antenna Type/ Pattern:	Whip/ Omni-Directional
	Terminations:	Reverse Polarity TN Connector
	Measurement:	Length: 56 cm (L) x 4 cm (W)
External Antenna 2	Model number:	32317
	Antenna Manufacturer:	Trimble Navigation
	Frequency :	890-960 MHz
	Maximum Gain	0 dBi
	Antenna Type/ Pattern:	Whip/ Omni-Directional
	Terminations:	Reverse Polarity Connector
	Measurement:	Length: 33 cm (L) x 4 cm (W)
External Antenna 3	Model number:	EXE902TNSP
	Antenna Manufacturer:	Centurion Wireless Technologies, Inc.
	Frequency :	896-940 MHz
	Maximum Gain	2.5 dBi
	Antenna Type/ Pattern:	Dipole/ Omni-Directional
	Terminations:	Reverse Polarity TN Connector
	Measurement:	Length: 17.8 cm (L) x 1.5 cm (W)

1.5 Objective

This Modular Approval report is prepared on behalf of *Trimble Navigation Limited* in accordance with Part 2, Subpart J, Part 15, Subparts A, B and C of the Federal Communication Commissions rules and Industry Canada RSS-210 Issue 7, June 2007 standard.

The objective is to determine compliance with FCC and IC standards, rules and limits for this device including:

- RF Exposure
- Antenna Requirement
- Conducted Emissions
- Spurious Emissions at Antenna Port
- Radiated Spurious Emissions
- Restricted Band
- Receiver Spurious Emissions
- Hopping Channel Separation
- 20 dB Bandwidth & 99% Bandwidth
- Number of Hopping Frequencies Used
- Dwell Time of Each Frequency
- Maximum Peak Output Power
- 100 kHz Bandwidth of Frequency Band Edge

1.6 Related Submittal(s)/Grant(s)

No related submittals.

1.7 Test Methodology

All measurements contained in this report were conducted in accordance with ANSI C63.4-2003, American National Standard for Methods of Measurement of Radio-Noise Emissions from Low-Voltage Electrical and Electronic Equipment in the range of 9 kHz to 40 GHz.

1.8 Measurement Uncertainty

All measurements involve certain levels of uncertainties, especially in field of EMC. The factors contributing to uncertainties are spectrum analyzer, cable loss, antenna factor calibration, antenna directivity, antenna factor variation with height, antenna phase center variation, antenna factor frequency interpolation, measurement distance variation, site imperfections, mismatch (average), and system repeatability.

Based on NIS 81, The Treatment of Uncertainty in EMC Measurements, the values range from +2.0 for Conducted Emissions tests and +4.0 dB for Radiated Emissions tests are the most accurate estimates pertaining to uncertainty of EMC measurements at BACL.

Detailed instrumentation measurement uncertainties can be found in BACL report QAP-018.

All radiated and conducted emissions measurement was performed at Bay Area Compliance Laboratory, Corp. The radiated testing was performed at an antenna-to-EUT distance of 3 meters.

1.9 Test Facility

The test site used by BACL Corp. to collect radiated and conducted emissions measurement data is located at its facility in Sunnyvale, California, USA.

The test sites at BACL have been fully described in reports submitted to the Federal Communication Commission (FCC) and Voluntary Control Council for Interference (VCCI). The details of these reports has been found to be in compliance with the requirements of Section 2.948 of the FCC Rules on February 11 and December 10, 1997 and Article 8 of the VCCI regulations on December 25, 1997. The facility also complies with the radiated and AC line conducted test site criteria set forth in ANSI C63.4-2003.

The Federal Communications Commission, Industry Canada, and Voluntary Control Council for Interference has the reports on file and is listed under FCC registration number: 90464, IC registration number: 3062A, and VCCI Registration Number: C-2463 and R-2698. The test site has been approved by the FCC, IC, and VCCI for public use and is listed in the FCC Public Access Link (PAL) database.

Additionally, BACL is a National Institute of Standards and Technology (NIST) accredited laboratory, under the National Voluntary Laboratory Accredited Program (Lab Code 200167-0). The current scope of accreditations can be found at <http://ts.nist.gov/Standards/scopes/2001670.htm>

2 SYSTEM TEST CONFIGURATION

2.1 Justification

The host system was configured for testing according to ANSI C63.4-2003.

The EUT was tested in the testing mode to represent *worst*-case results during the final qualification test.

2.2 EUT Exercise Software

Provided by Manufacturer

2.3 Special Accessories

The EUT was installed in a host system to simulate real world operating conditions.

2.4 Equipment Modifications

No modifications were made to the EUT.

2.5 Local Support Equipment List and Details

Manufacturer	Description	Model	Serial Number
Dell	Laptop	D620	-

2.6 Host System Details

Manufacturer	Description	Model	Serial Number
Trimble Navigation	GPS Receiver	SPSx81	8978

2.7 Host System Power Supply Information

Manufacturer	Description	Model/ Rev. #	Serial Number
AULT Korea Corp.	ITE Power Supply	PW174KA1802FXX	82-31-299-1234

2.8 Test Setup Block Diagrams

Conducted Emissions

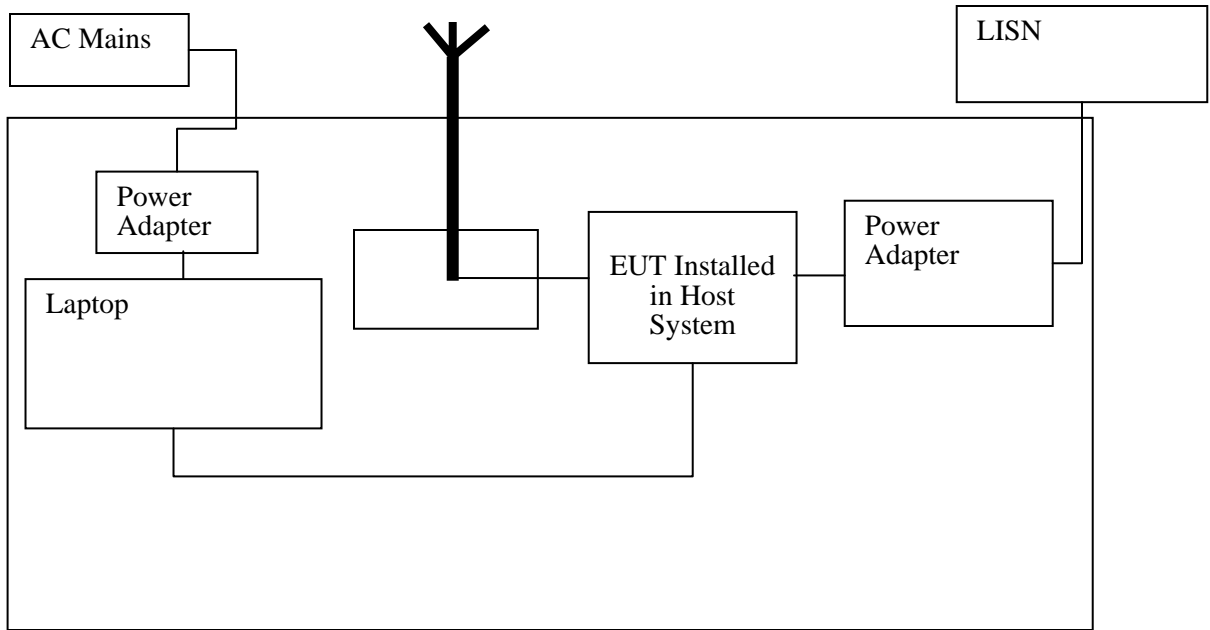

Radiated Emissions

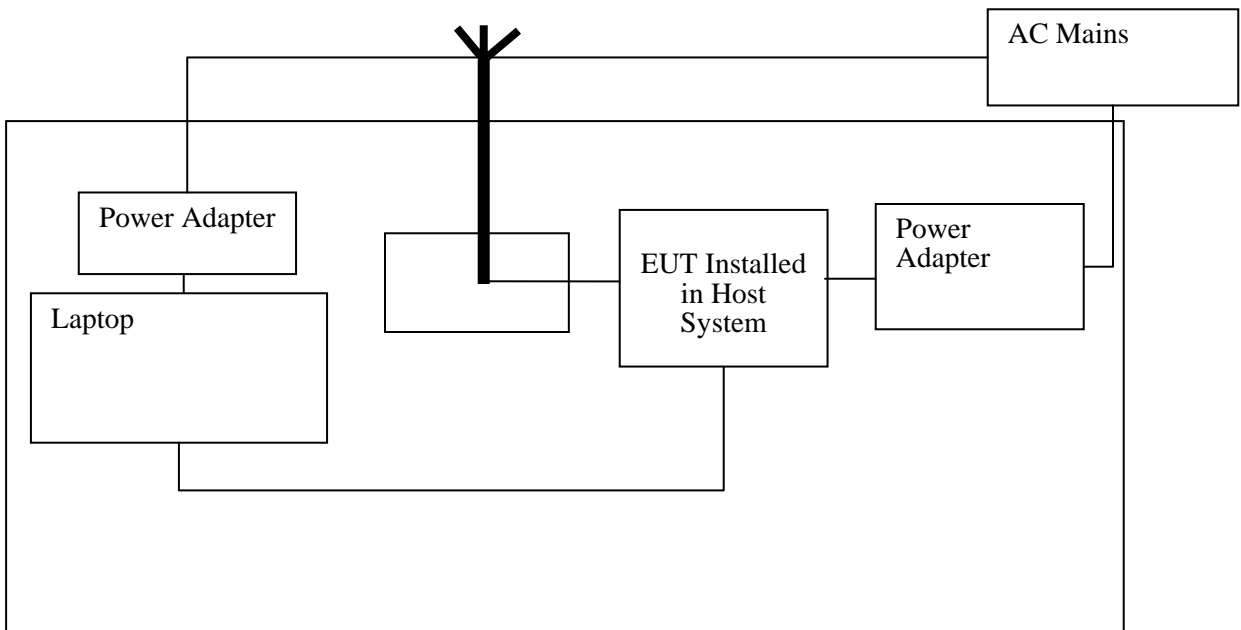

3 SUMMARY OF TEST RESULTS

Results reported relate only to the product tested.

FCC 15C / RSS-210 Rules	Description of Test	Result	Note
FCC §15.247 (i) and §2.1091, IC RSS-Gen 5.5 & RSS-102	RF Exposure	Compliant	-
FCC §15.203, IC RSS-Gen §7.1.4	Antenna Requirement	Compliant	-
FCC §15.207 (a), IC RSS-Gen §7.2.2	Conducted Emissions	Compliant	-
FCC §15.247(d), RSS210 § A8.5 § RSS-Gen §7.2	Spurious Emissions at Antenna Port	Compliant	-
FCC §15.205, §15.209 & §15.247(c), IC RSS-210 §A8.5	Radiated Spurious Emissions	Compliant	-
FCC §15.205, RSS-210 §A8.5	Restricted Band	Compliant	-
§15.109 & RSS-Gen §6(a)	Receiver Spurious Emissions	Compliant	-
§15.247 (a)(1), RSS-210 §A8.1 (a)	20 dB Bandwidth & 99% Bandwidth	Compliant	-
§15.247 (a)(1), RSS-210 §A8.1(2)	Hopping Channel Separation	Compliant	-
§15.247 (a)(1)(iii), RSS-210 §A8.1(4)	Number of Hopping Frequencies Channel Used	Compliant	-
§15.247 (a)(1)(iii), RSS-210 §A8.1(4)	Dwell Time	Compliant	-
§15.247 (b)(3), RSS210 § A8.4	Maximum Peak Output Power	Compliant	-
§ 15.247 (d), RSS210 § A8.5	100 kHz Bandwidth of Frequency Band Edge	Compliant	-

4 FCC §15.247 (i) and §2.1091, IC RSS-Gen 5.5 & RSS-102 - RF Exposure

4.1 Applicable Standard

According to §15.247(e)(i) and §1.1307(b)(1), systems operating under the provisions of this section shall be operated in a manner that ensures that the public is not exposed to radio frequency energy level in excess of the Commission's guidelines.

According to §1.1310 and §2.1091 RF exposure is calculated.

Limits for General Population/Uncontrolled Exposure

Frequency Range (MHz)	Electric Field Strength (V/m)	Magnetic Field Strength (A/m)	Power Density (mW/cm ²)	Averaging Time (minutes)
Limits for General Population/Uncontrolled Exposure				
0.3-1.34	614	1.63	*(100)	30
1.34-30	824/f	2.19/f	*(180/f ²)	30
30-300	27.5	0.073	0.2	30
300-1500	/	/	f/1500	30
1500-100,000	/	/	1.0	30

f = frequency in MHz

* = Plane-wave equivalent power density

4.2 MPE Prediction

Prediction of MPE limit at a given distance

Equation from page 18 of OET Bulletin 65, Edition 97-01

$$S = PG/4\pi R^2$$

Where: S = power density

P = power input to antenna

G = power gain of the antenna in the direction of interest relative to an isotropic radiator

R = distance to the center of radiation of the antenna

Maximum peak output power at antenna input terminal (dBm):29.66

Maximum peak output power at antenna input terminal (mW):924.698

Prediction distance (cm):20

Prediction frequency (MHz):928

Maximum Antenna Gain, typical (dBi):5

Maximum Antenna Gain (numeric):3.16

Power density of prediction frequency at 20.0 cm (mW/cm²):0.581

MPE limit for uncontrolled exposure at prediction frequency (mW/cm²):0.619

4.3 Test Result

The power density level at 20 cm is 0.581 mW/cm², which is below the uncontrolled exposure limit of 0.619 mW/cm² at 928 MHz.

5 FCC §15.203, IC RSS-Gen §7.1.4 – Antenna Requirement

5.1 Applicable Standard

According to § 15.203, an intentional radiator shall be designed to ensure that no antenna other than that furnished by the responsible party shall be used with the device.

And according to § 15.247 (b)(4), if transmitting antennas of directional gain greater than 6 dBi are used the power shall be reduced by the amount in dB that the directional gain of the antenna exceeds 6 dBi.

The antennas for the EUT are two whip antennas which connect to the EUT via a RF cable and one dipole antenna which connects directly to the EUT. The gains of the whip antennas used for transmitting are: 3 dBi and 0 dBi. The dipole antenna is 2 dBi. Please see the photos below for details.

5.2 Result

The Antennas used are: 2 whip antennas with gains of: 3 dBi, and 0 dBi, and a dipole antenna with a gain of: 2 dBi. All antennas use reverse polarity TNC which complies with the unique connector requirement.

Item Number	Model/Type	
External Antenna 1	Model number:	32318
	Antenna Manufacturer:	Trimble Navigation
	Frequency :	890-960 MHz
	Maximum Gain	3 dBi
	Antenna Type/ Pattern:	Whip/ Omni-Directional
	Terminations:	Positive Male-Female
	Measurement:	Length: 56 cm (L) x 4 cm (W)
External Antenna 2	Model number:	32317
	Antenna Manufacturer:	Trimble Navigation
	Frequency :	890-960 MHz
	Maximum Gain	0 dBi
	Antenna Type/ Pattern:	Whip/ Omni-Directional
	Terminations:	Positive Male-Female
	Measurement:	Length: 33 cm (L) x 4 cm (W)
External Antenna 3	Model number:	EXE902TNSP
	Antenna Manufacturer:	Centurion Wireless Technologies, Inc.
	Frequency :	896-940 MHz
	Maximum Gain	2.5 dBi
	Antenna Type/ Pattern:	Dipole/ Omni-Directional
	Terminations:	Reverse Polarity TN Connector
	Measurement:	Length: 17.8 cm (L) x 1.5 cm (W)

Please refer to the antenna photos below:

External Antenna 1:



External Antenna 2:



External Antenna 3:



Compliant

N/A

6 FCC §15.207 (a), IC RSS-Gen §7.2.2 - Conducted Emissions

6.1 Applicable Standard

According to FCC §15.207 (a) Except as shown in paragraphs (b) and (c) of this section, for an intentional radiator that is designed to be connected to the public utility (AC) power line, the radio frequency voltage that is conducted back onto the AC power line on any frequency or frequencies within the band 150 kHz to 30 MHz shall not exceed the limits in the following table, as measured using a 50 μ H/50 ohms line impedance stabilization network (LISN). Compliance with the provisions of this paragraph shall be based on the measurement of the radio frequency voltage between each power line and ground at the power terminal. The lower limit applies at the boundary between the frequencies ranges.

Frequency of Emission (MHz)	Conducted limit (dB μ V)	
	Quasi-peak	Average
0.15-0.5	66 to 56*	56 to 46*
0.5-5	56	46
5-30	60	50

**Decreases with the logarithm of the frequency*

6.2 Test Setup

The measurement was performed at shield room, using the setup per ANSI C63.4 – 2003 measurement procedure. The specification used was FCC Class B limits.

External I/O cables were draped along the edge of the test table and bundle when necessary.

The EUT was connected with LISN-1.

6.3 Test Equipment List and Details

Manufacturer	Description	Model	Serial Number	Calibration Date
Rohde & Schwarz	EMI Test Receiver	ESCI 1166.595 0K03	100044	2007-02-19
Solar Electronics CO	Artificial-Mains Network	9252-50-R- 24-N	0511213	2007-07-30

*** Statement of Traceability:** BACL Corp. attests that all calibrations have been performed per the NVLAP requirements, traceable to the NIST.

6.4 Test Procedure

During the conducted emissions test, the power cord of the EUT was connected to the mains outlet of the LISN-1.

Maximizing procedure was performed on the six (6) highest emissions of the EUT.

All data was recorded in the peak detection mode, quasi-peak and average. Quasi-Peak readings are distinguished with a “QP”. Average readings are distinguished with an “Ave”.

Environmental Conditions

Temperature:	24 ° C
Relative Humidity:	65 %
ATM Pressure:	1020 mbar

**The testing was performed by Choon Sian Ooi on 2007-11-20.*

6.5 Summary of Test Results

According to the recorded data in following table, the EUT complied with the applicable FCC Rules and IC Standards, conducted emissions limits for Class B devices, with the *worst* margin reading of:

Mode: 120V/ 60 Hz			
Margin (dB)	Frequency (MHz)	Conductor (Hot/Neutral)	Range (MHz)
-8.4	0.521000	Hot	0.15 to 30

Please refer to the following plots and tables for complete test results

Conducted Emissions Test plot & data

Hot Conductor Mode

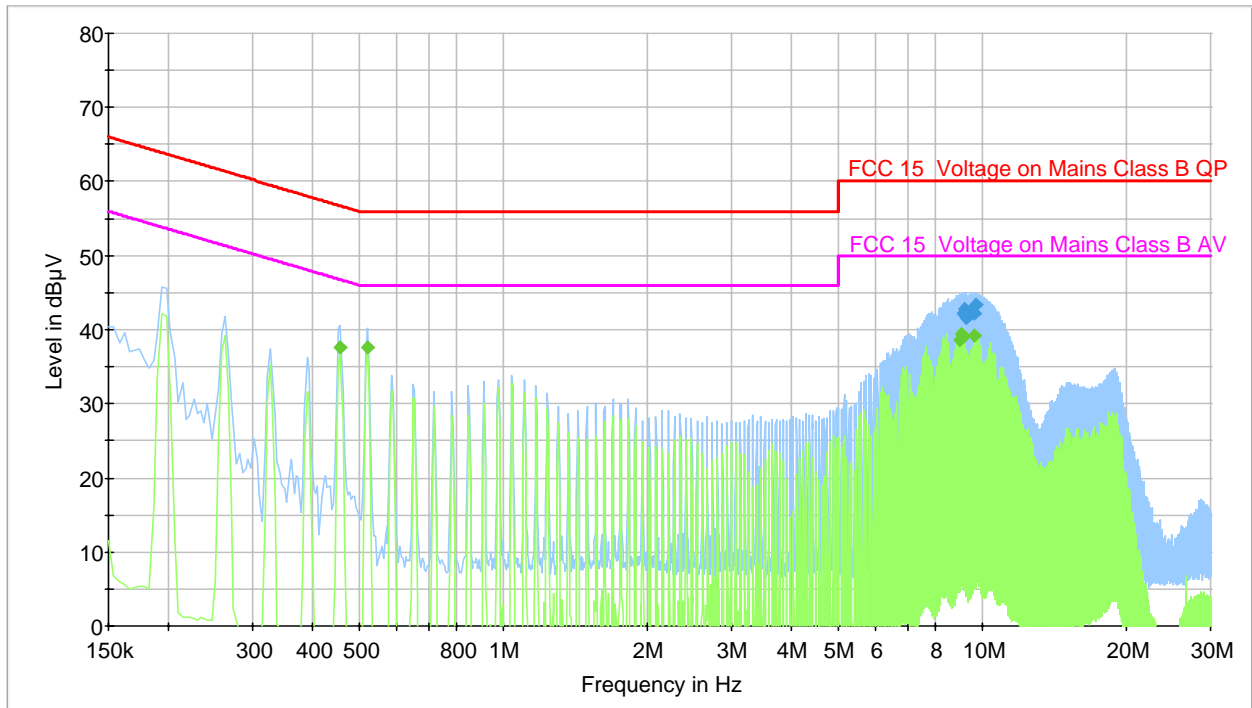

QP Measurements

Frequency (MHz)	Quasi-Peak (dBµV)	Conductor (H/N)	Corrected Factor (dB)	Limit (dBµV)	Margin (dB)
9.709000	43.4	H	12.4	56.0	-16.6
9.189000	42.8	H	12.4	62.3	-17.2
9.513000	42.6	H	12.4	56.0	-17.4
9.121000	42.2	H	12.4	64.8	-17.8
9.645000	42.2	H	12.4	56.0	-17.9
9.253000	41.6	H	12.4	57.6	-18.4

Average Measurements

Frequency (MHz)	Average (dBµV)	Conductor (H/N)	Corrected Factor (dB)	Limit (dBµV)	Margin (dB)
0.521000	37.6	H	12.3	46.0	-8.4
0.457000	37.5	H	12.3	46.7	-9.2
9.057000	39.4	H	12.4	50.0	-10.6
9.641000	39.1	H	12.4	50.0	-10.9
9.121000	39.0	H	12.4	50.0	-11.0
8.993000	38.6	H	12.4	50.0	-11.4

Neutral Conductor Mode

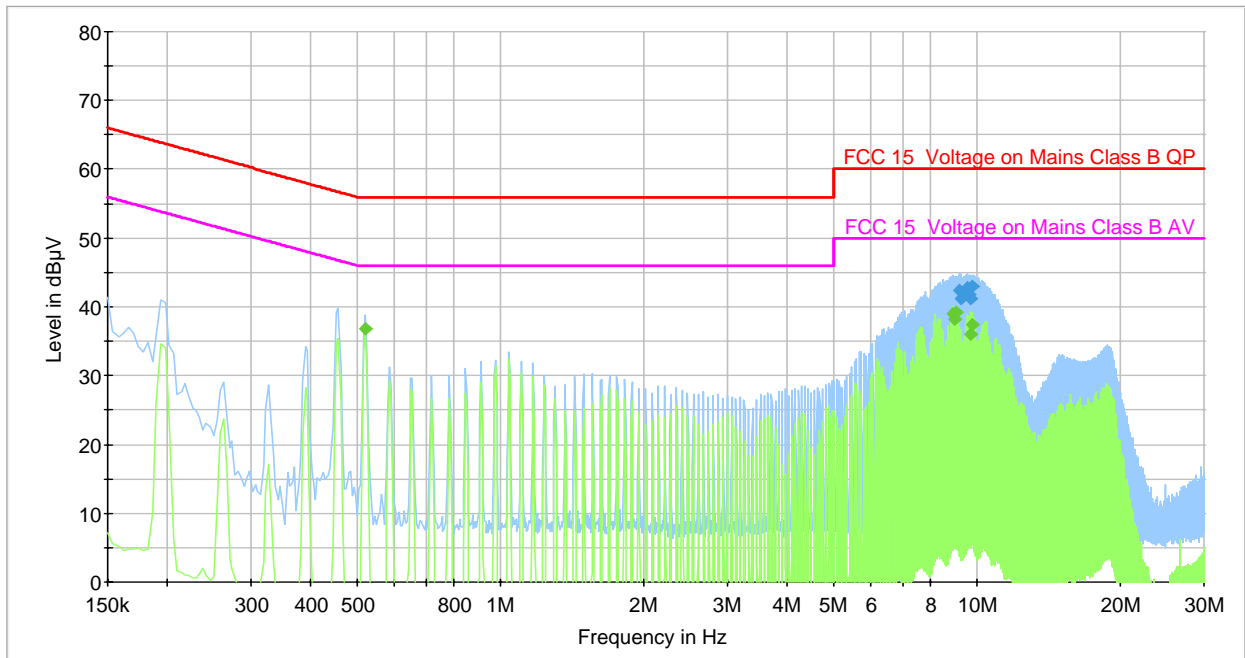

QP Measurements

Frequency (MHz)	Quasi-Peak (dBµV)	Conductor (H/N)	Corrected Factor (dB)	Limit (dBµV)	Margin (dB)
9.774000	43.0	N	12.4	60.0	-17.0
9.578000	42.8	N	12.4	60.0	-17.2
9.190000	42.5	N	12.4	60.0	-17.5
9.642000	41.9	N	12.4	60.0	-18.1
9.254000	41.2	N	12.4	60.0	-18.8
9.706000	41.2	N	12.4	60.0	-18.8

Average Measurements

Frequency (MHz)	Average (dBµV)	Conductor (H/N)	Corrected Factor (dB)	Limit (dBµV)	Margin (dB)
0.522000	36.8	N	12.3	46.0	-9.2
9.058000	39.2	N	12.4	50.0	-10.8
8.926000	38.9	N	12.4	50.0	-11.1
8.990000	38.2	N	12.4	50.0	-11.8
9.774000	37.3	N	12.4	50.0	-12.7
9.706000	35.9	N	12.4	50.0	-14.1

7 FCC §15.247(d), RSS-210 § A8.5 & RSS-Gen 7.2 - Spurious Emissions at Antenna Terminals

7.1 Applicable Standard

According to §15.247 (d) In any 100 kHz bandwidth outside the frequency band in which the spread spectrum or digitally modulated intentional radiator is operating, the radio frequency power that is produced by the intentional radiator shall be at least 20 dB below that in the 100 kHz bandwidth within the band that contains the highest level of the desired power, based on either an RF conducted or a radiated measurement, provided the transmitter demonstrates compliance with the peak conducted power limits. If the transmitter complies with the conducted power limits based on the use of RMS averaging over a time interval, as permitted under paragraph (b)(3) of this section, the attenuation required under this paragraph shall be 30 dB instead of 20 dB. Attenuation below the general limits specified in §15.209(a) is not required. In addition, radiated emissions which fall in the restricted bands, as defined in §15.205(a), must also comply with the radiated emission limits specified in §15.209(a) (see §15.205(c)).

7.2 Measurement Procedure

1. Check the calibration of the measuring instrument (SA) using either an internal calibrator or a known signal from an external generator.
2. Position the EUT on a bench without connection to measurement instrument. Turn on the EUT and connect its antenna terminal to measurement instrument via a low loss cable. Then set it to any one measured frequency within its operating range, and make sure the instrument is operated in its linear range.
3. Set the SA on Max-Hold Mode, and then keep the EUT in transmitting mode. Record all the signals from each channel until each one has been recorded.
4. Set the SA on View mode and then plot the result on SA screen.
5. Repeat above procedures until all frequencies measured were complete.

7.3 Test Equipment

Manufacturer	Description	Model Number	Serial Number	Calibration Date
Agilent	Spectrum Analyzer	E4446A	US44300386	2007-04-26

* **Statement of Traceability: BACL Corp.** attests that all calibrations have been performed per the NVLAP requirements, traceable to the NIST.

7.4 Test Setup Diagram

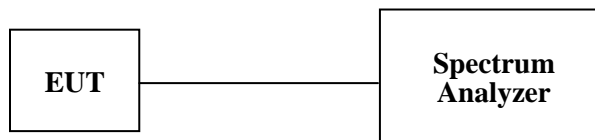

7.5 Environmental Conditions

Temperature:	28.5 °C
Relative Humidity:	45 %
ATM Pressure:	102.7 kPa

*The testing was performed by Choon Sian Ooi on 2007-11-28

Please refer to the following plots.

7.6 Measurement Results

Low Channel

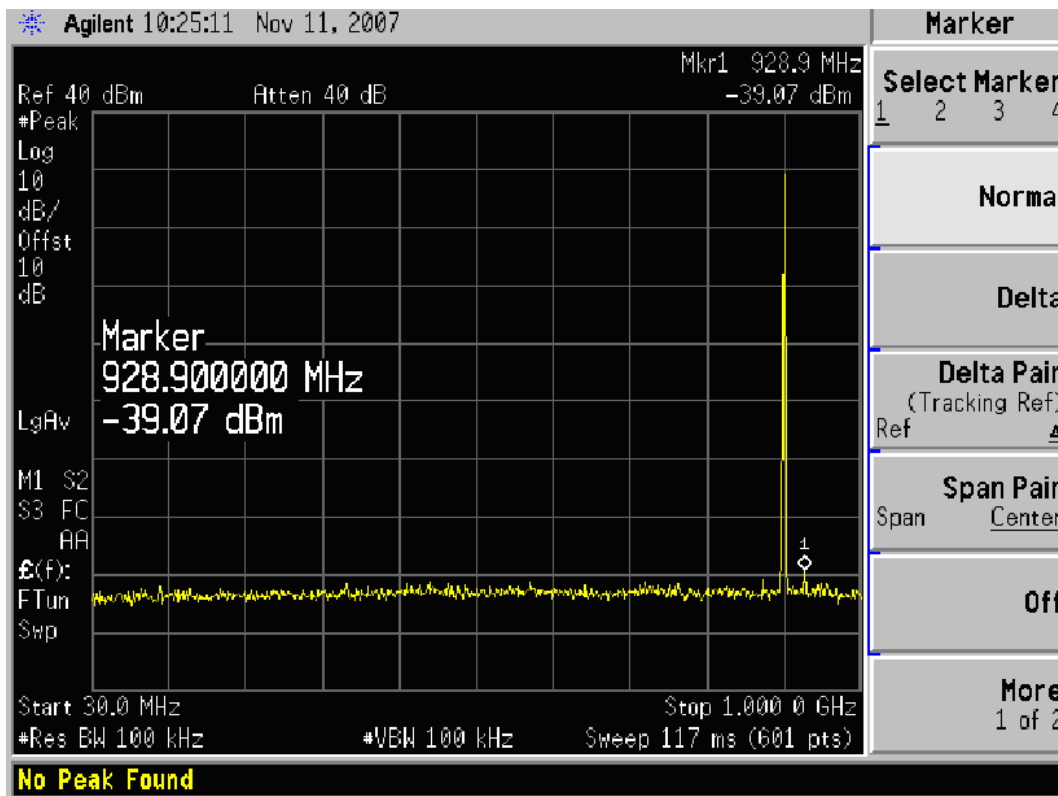

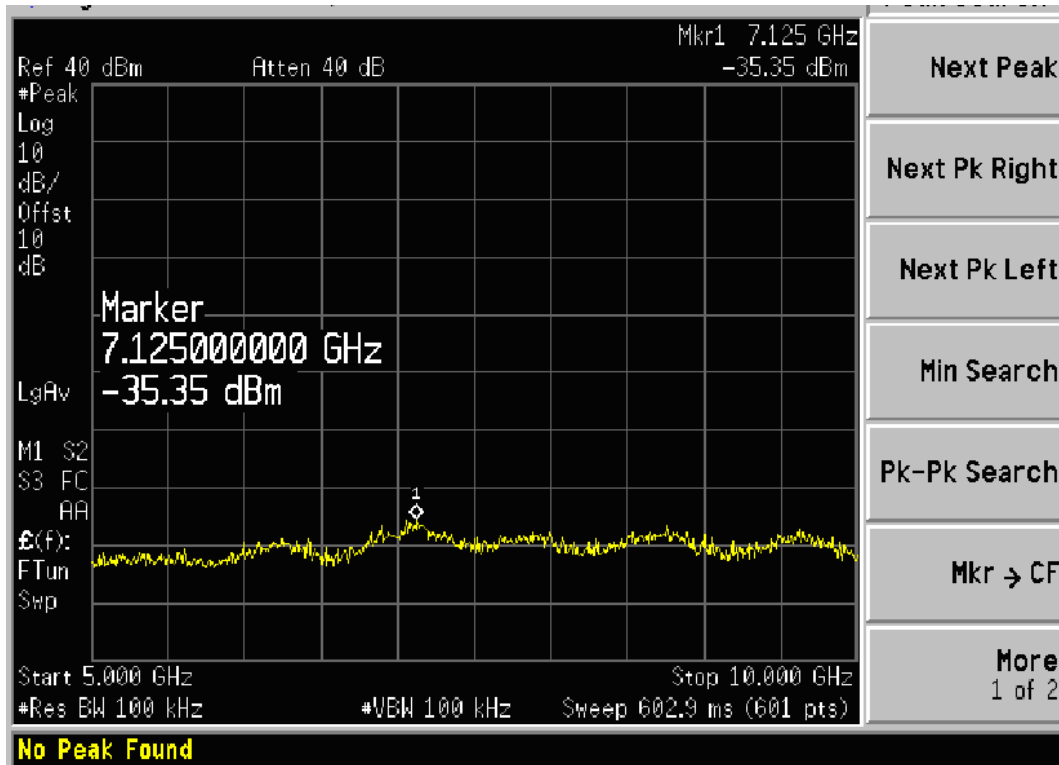
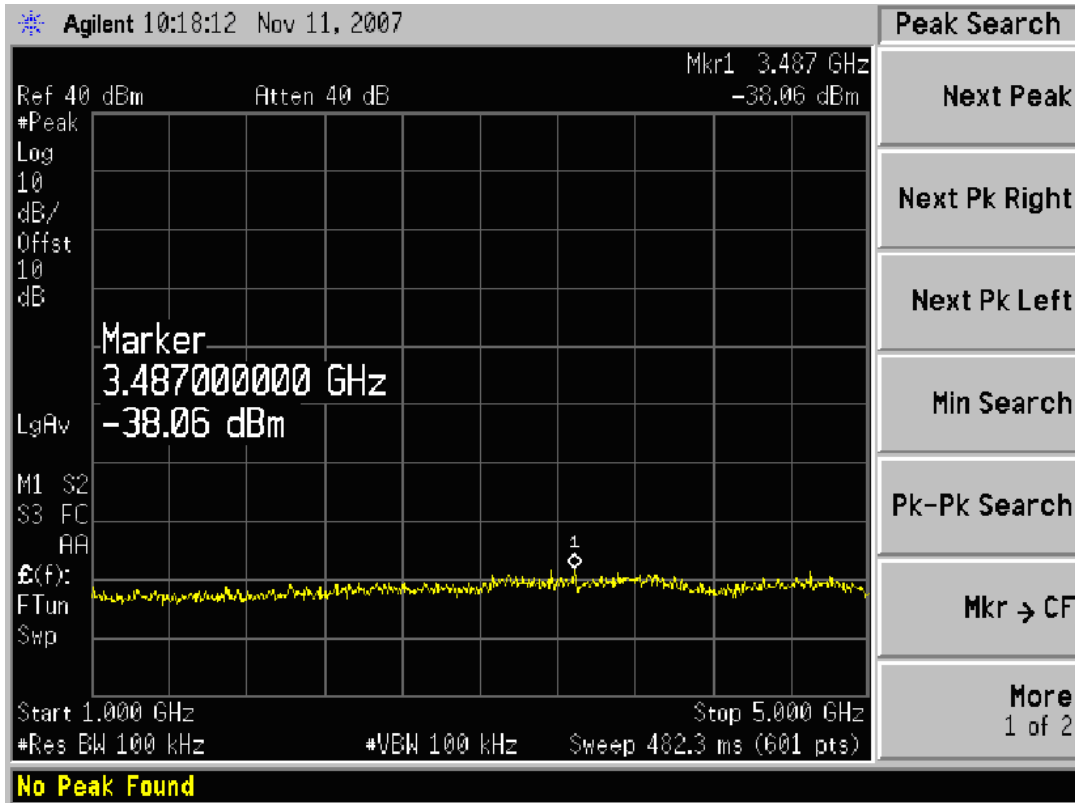

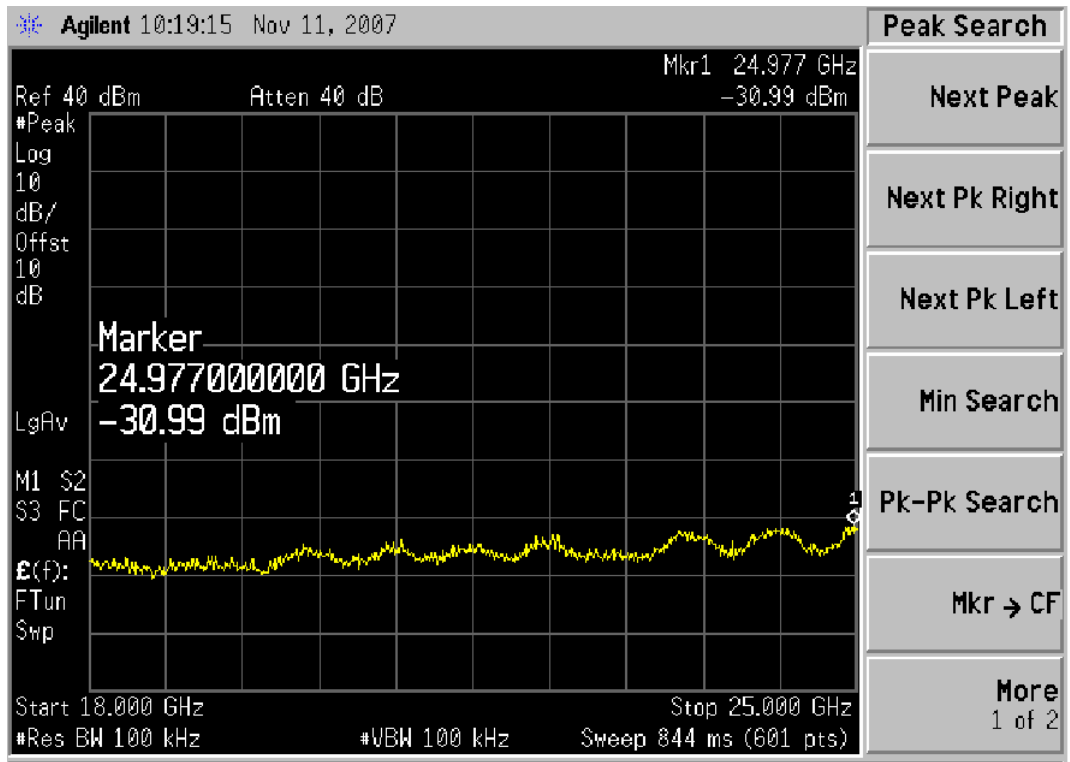
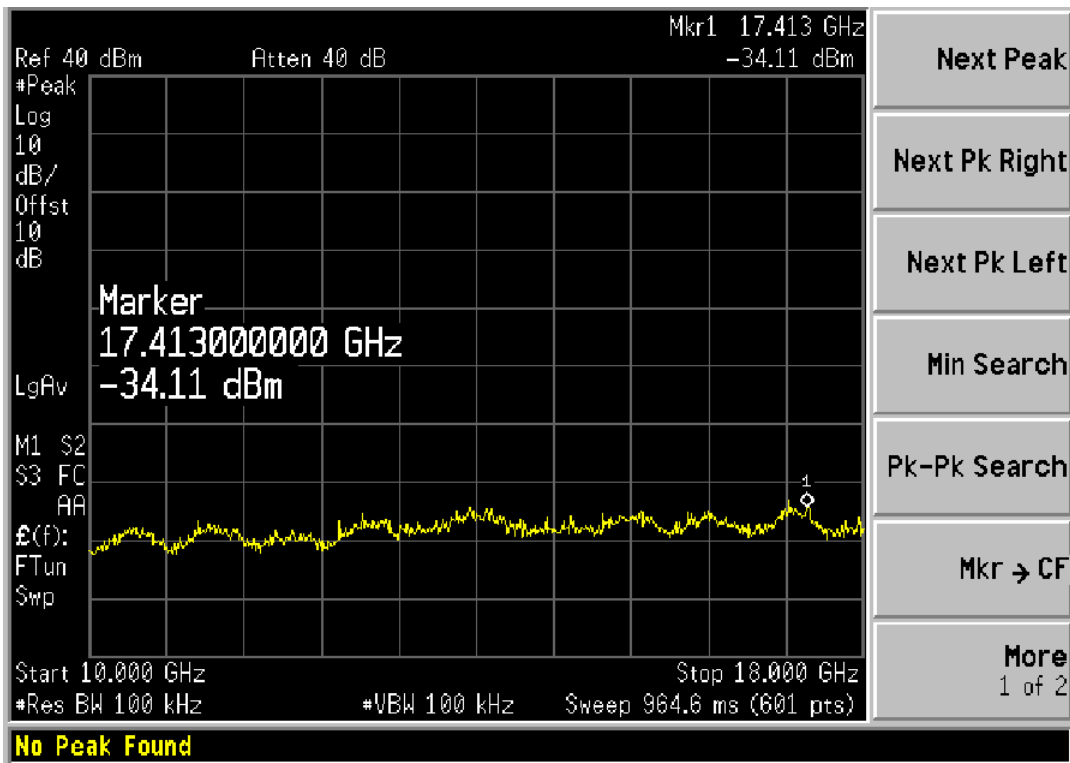

Middle Channel

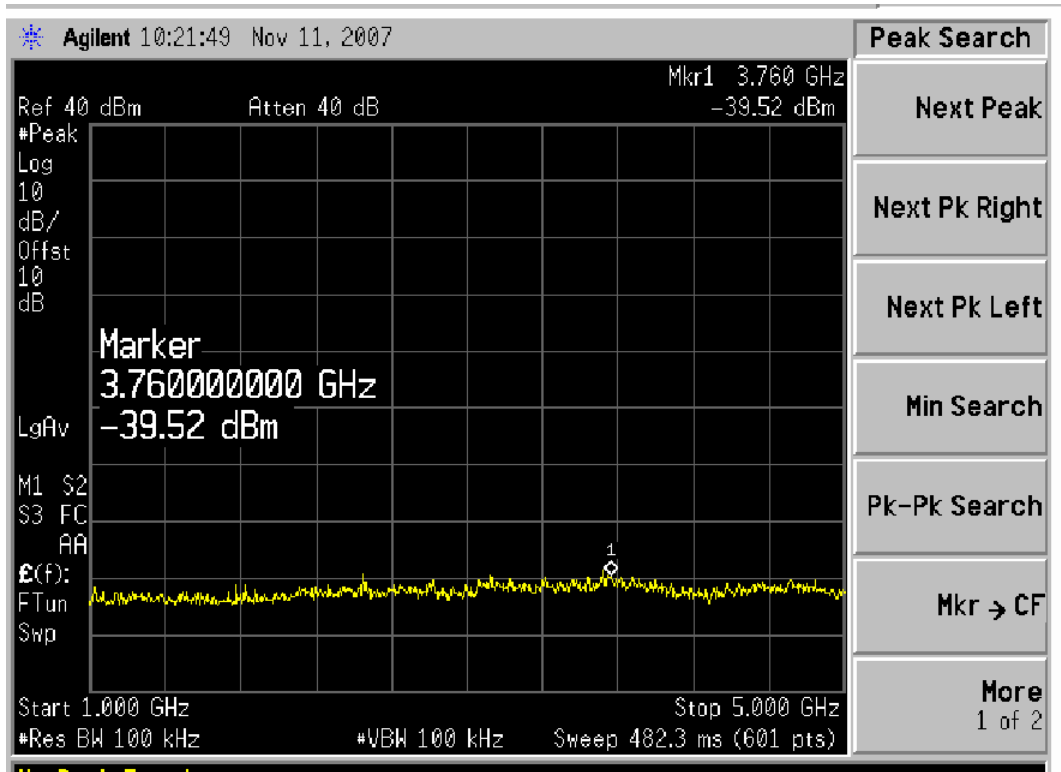
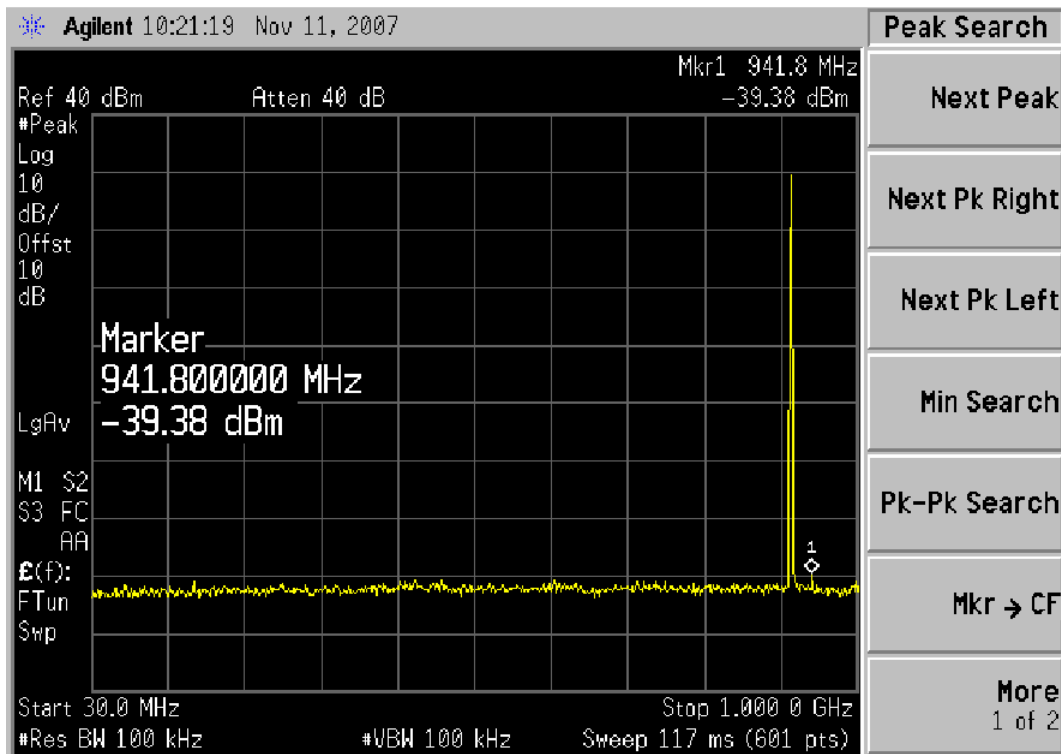

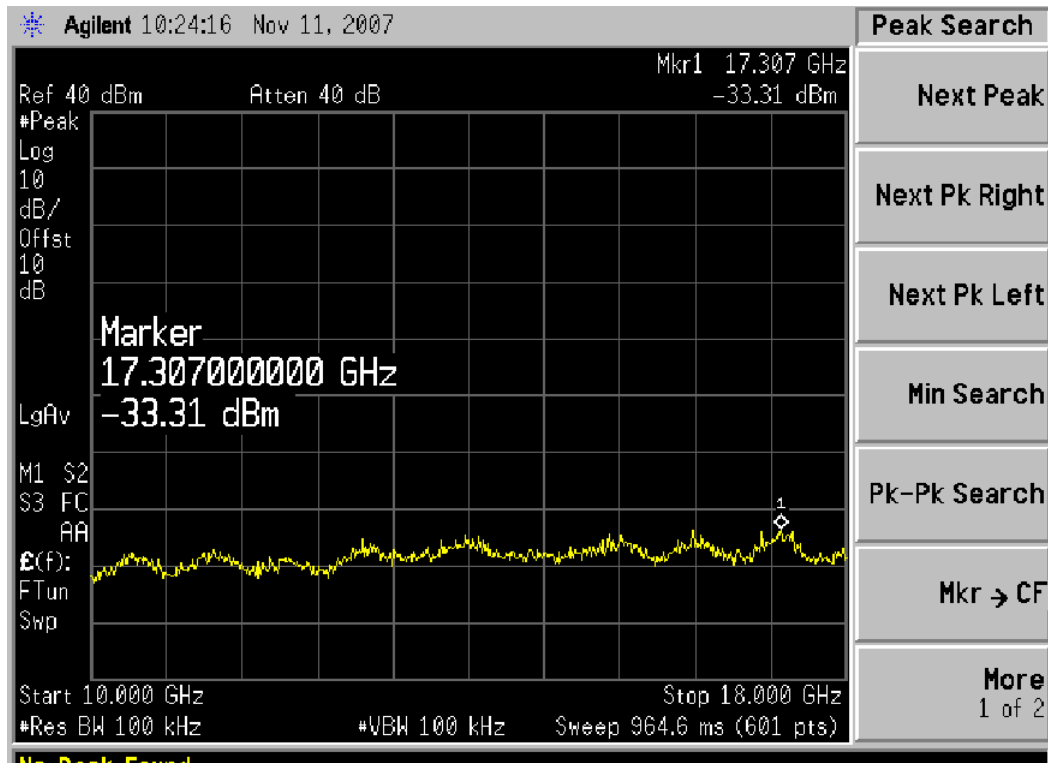
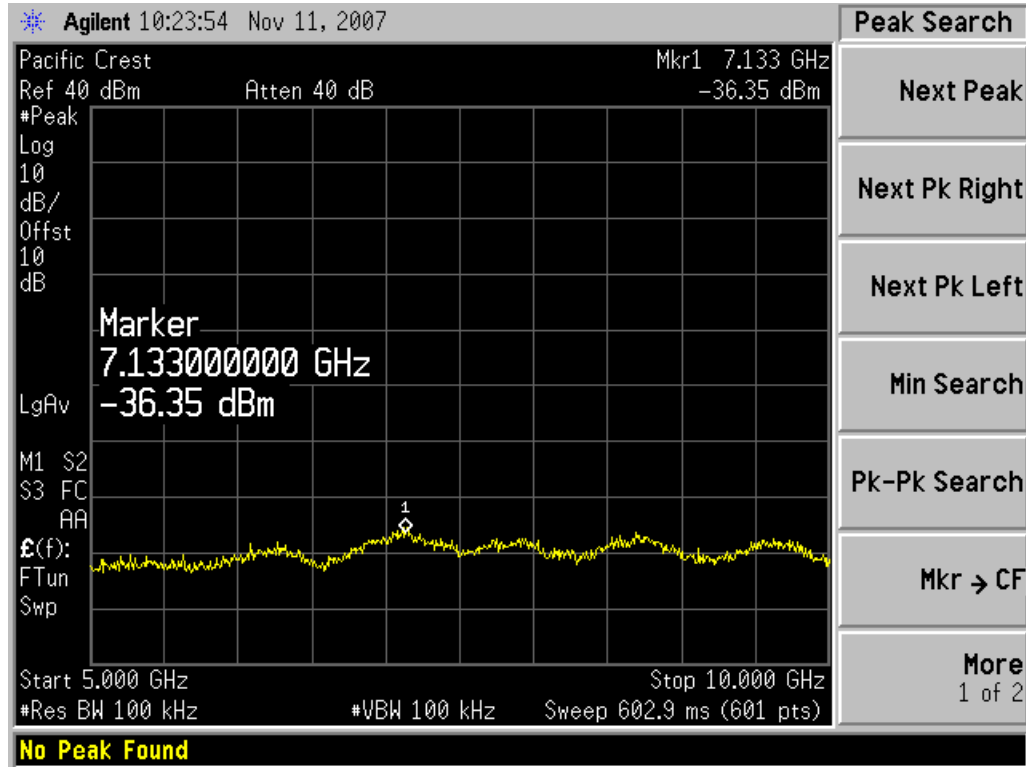

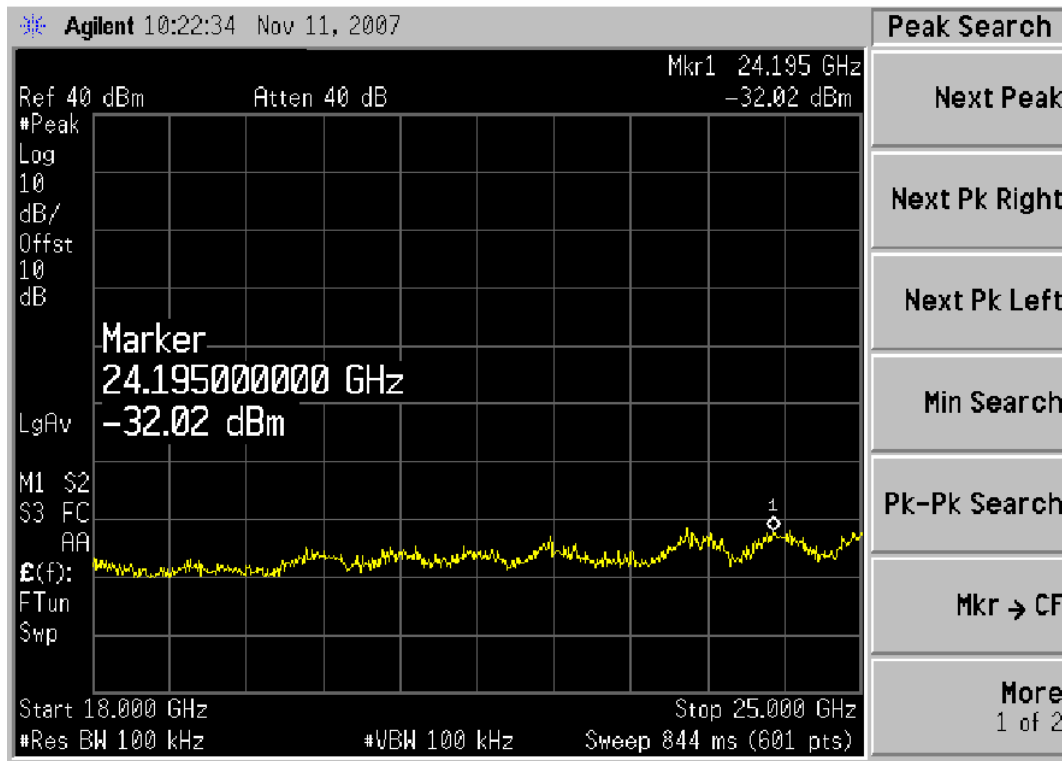

High Channel

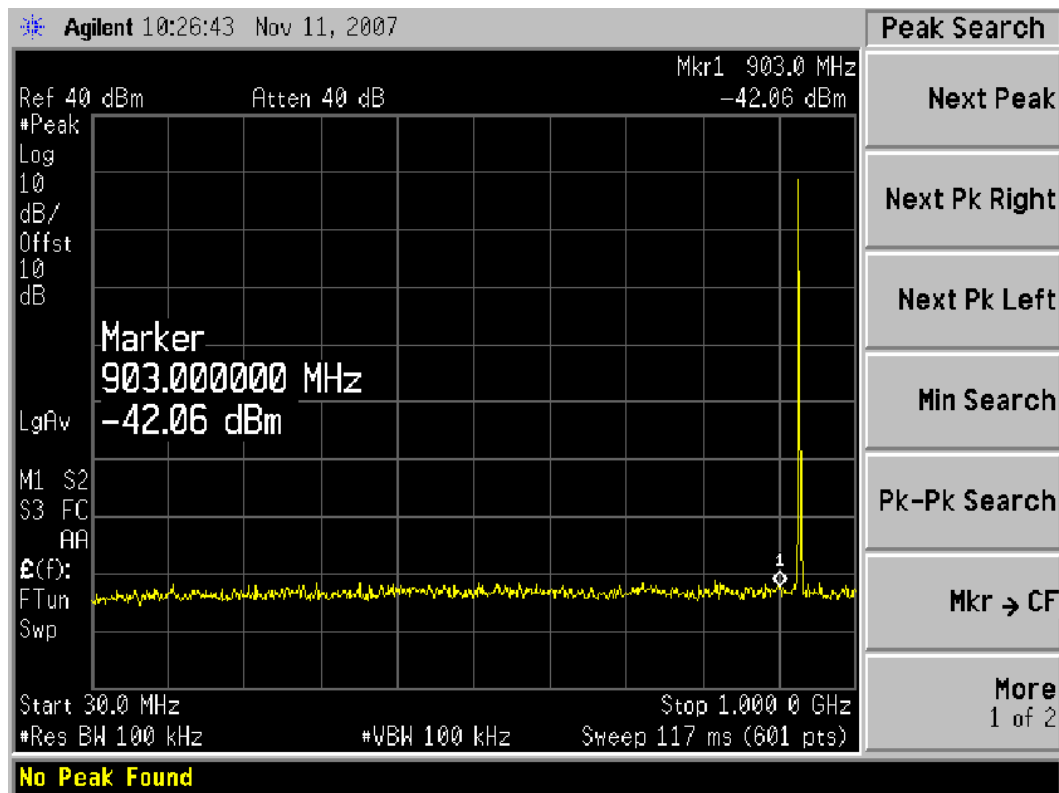

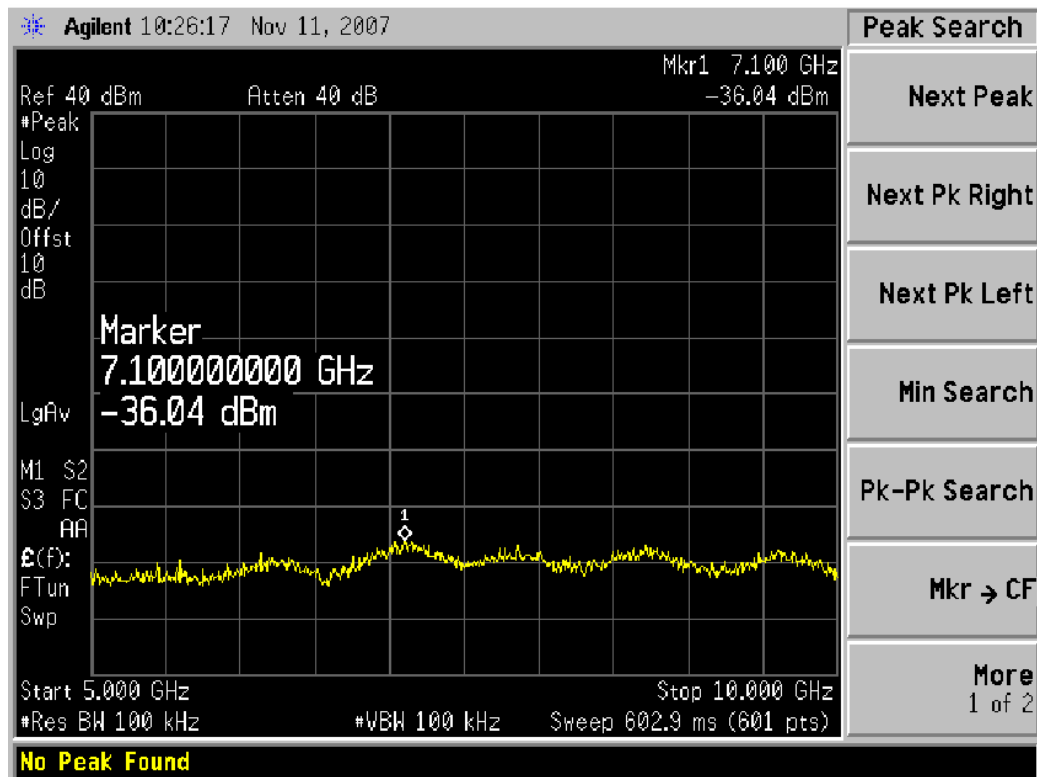
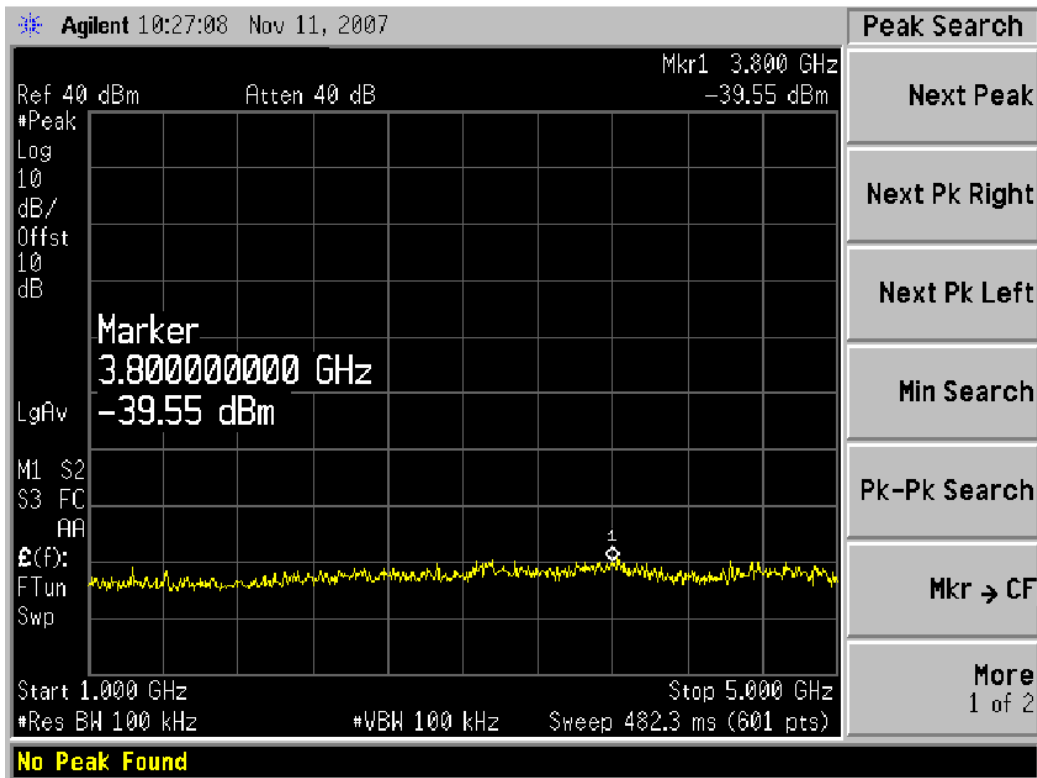

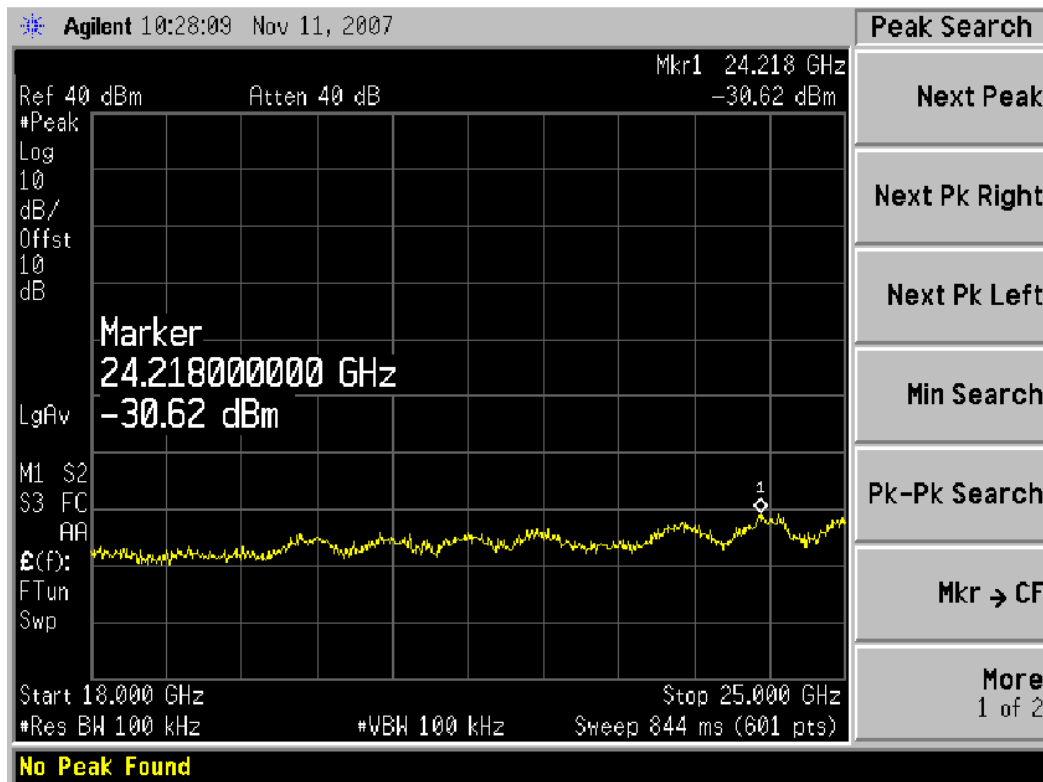
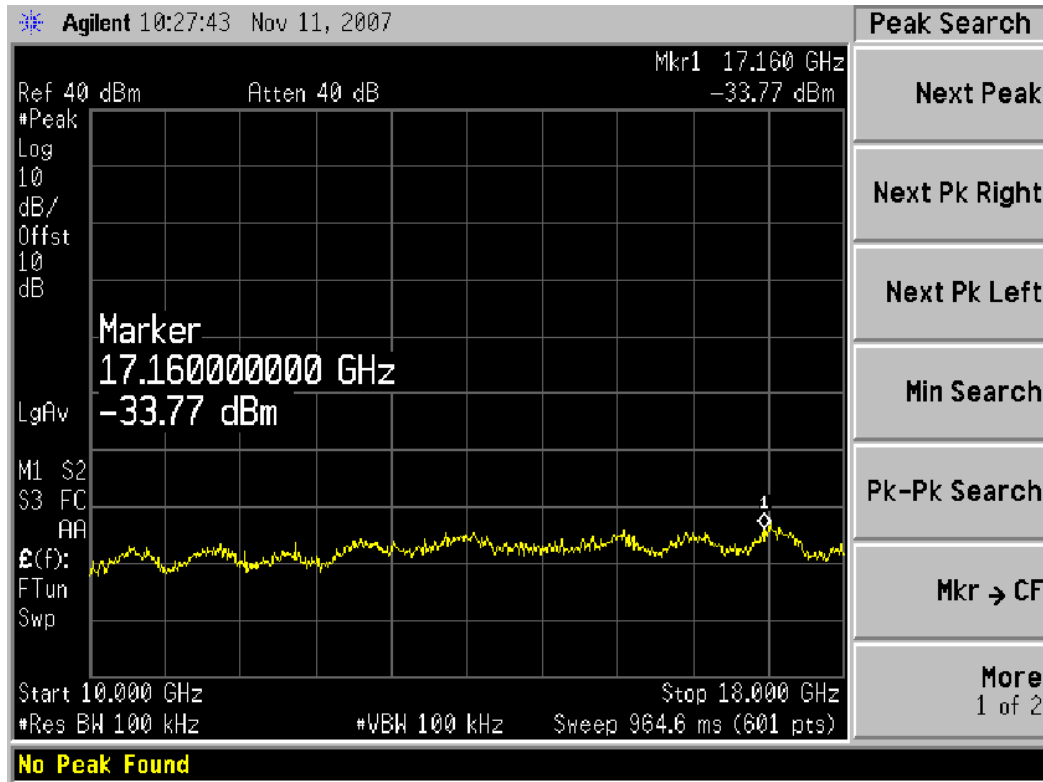

8 FCC §15.205, §15.209 & §15.247(c), IC RSS-210 §A8.5 - Spurious Radiated Emissions

8.1 Applicable Standard

As per FCC §15.35(d): Unless otherwise specified, on any frequency or frequencies above 1000 MHz, the radiated emission limits are based on the use of measurement instrumentation employing an average detector function. Unless otherwise specified, measurements above 1000 MHz shall be performed using a minimum resolution bandwidth of 1 MHz.

As per FCC §15.209(a): Except as provided elsewhere in this Subpart, the emissions from an intentional radiator shall not exceed the field strength levels specified in the following table

Frequency (MHz)	Field Strength (micro volts/meter)	Measurement Distance (meters)
0.009 - 0.490	2400/F(kHz)	300
0.490 - 1.705	24000/F(kHz)	30
1.705 - 30.0	30	30
30 - 88	100**	3
88 - 216	150**	3
216 - 960	200**	3
Above 960	500	3

** Except as provided in paragraph (g), fundamental emissions from intentional radiators operating under this Section shall not be located in the frequency bands 54-72 MHz, 76-88 MHz, 174-216 MHz or 470-806 MHz. However, operation within these frequency bands is permitted under other sections of this Part, e.g., Sections 15.231 and 15.241.

As per FCC §15.247(c)(1)(i): Systems operating in the 2400-2483.5 MHz band that are used exclusively for fixed, point-to-point operations may employ transmitting antennas with directional gain greater than 6 dBi provided the maximum conducted output power of the intentional radiator is reduced by 1 dB for every 3 dB that the directional gain of the antenna exceeds 6 dBi.

As Per FCC §15.205(a) except as show in paragraph (d) of this section, only spurious emissions are permitted in any of the frequency bands listed below:

MHz	MHz	MHz	GHz
0.090 – 0.110	16.42 – 16.423	960 – 1240	4.5 – 5.15
0.495 – 0.505	16.69475 – 16.69525	1300 – 1427	5.35 – 5.46
2.1735 – 2.1905	25.5 – 25.67	1435 – 1626.5	7.25 – 7.75
4.125 – 4.128	37.5 – 38.25	1645.5 – 1646.5	8.025 – 8.5
4.17725 – 4.17775	73 – 74.6	1660 – 1710	9.0 – 9.2
4.20725 – 4.20775	74.8 – 75.2	1718.8 – 1722.2	9.3 – 9.5
6.215 – 6.218	108 – 121.94	2200 – 2300	10.6 – 12.7
6.26775 – 6.26825	123 – 138	2310 – 2390	13.25 – 13.4
6.31175 – 6.31225	149.9 – 150.05	2483.5 – 2500	14.47 – 14.5
8.291 – 8.294	156.52475 – 156.52525	2690 – 2900	15.35 – 16.2
8.362 – 8.366	156.7 – 156.9	3260 – 3267	17.7 – 21.4
8.37625 – 8.38675	162.0125 – 167.17	3.332 – 3.339	22.01 – 23.12
8.41425 – 8.41475	167.72 – 173.2	3 3458 – 3 358	23.6 – 24.0
12.29 – 12.293	240 – 285	3.600 – 4.400	31.2 – 31.8
12.51975 – 12.52025	322 – 335.4		36.43 – 36.5
12.57675 – 12.57725	399.9 – 410		Above 38.6
13.36 – 13.41	608 – 614		

As per FCC §15.247 (d) In any 100 kHz bandwidth outside the frequency band in which the spread spectrum or digitally modulated intentional radiator is operating, the radio frequency power that is produced by the intentional radiator shall be at least 20 dB below that in the 100 kHz bandwidth within the band that contains the highest level of the desired power, based on either an RF conducted or a radiated measurement, provided the transmitter demonstrates compliance with the peak conducted power limits. If the transmitter complies with the conducted power limits based on the use of RMS averaging over a time interval, as permitted under paragraph (b)(3) of this section, the attenuation required under this paragraph shall be 30 dB instead of 20 dB. Attenuation below the general limits specified in §15.209(a) is not required. In addition, radiated emissions which fall in the restricted bands, as defined in §15.205(a), must also comply with the radiated emission limits specified in §15.209(a) (see §15.205(c)).

IC RSS-GEN §4.9 the measurement method shall be described in the test report. The same parameter, peak power or average power, used for the transmitter output power measurement shall be used for unwanted emission measurements. The search for unwanted emissions shall be from the lowest frequency internally generated or used in the device (local oscillator, intermediate or carrier frequency), or from 30 MHz, whichever is the lower, to the 5th harmonic of the highest frequency generated without exceeding 40 GHz.

8.2 Test Setup

The radiated emissions tests were performed in the 3-meter open area test site, using the setup in accordance with ANSI C63.4-2003. The specification used was the FCC 15 Subpart C limits.

8.3 EUT Setup

The radiated emissions tests were performed using the setup accordance with the ANSI C63.4-2003. The specification used was the FCC 15C limits.

The spacing between the peripherals was 10 centimeters.

External I/O cables were draped along the edge of the test table and bundle when necessary.

8.4 Test Equipment List and Details

Manufacturer	Description	Model	Serial Number	Calibration Date
Agilent	Spectrum Analyzer	E4446A	US44300386	2007-04-26
Sonoma Instruments	Pre amplifier	317	260407	2007-04-26
HP	Pre amplifier	8449B	3147A00400	2006-08-21
Sunol Science Corp	Combination Antenna	JB3 Antenna	A020106-3	2007-03-05
A.R.A	Antenna Horn	DRG-118/A	1132	2007-06-18

* **Statement of Traceability:** BACL attests that all calibrations have been performed per the NVLAP requirements, traceable to NIST.

8.5 Test Procedure

For the radiated emissions test, the EUT, and all support equipment power cords was connected to the AC floor outlet.

Maximizing procedure was performed on the highest emissions to ensure that the EUT complied with all installation combinations.

The EUT is set 3 meters away from the testing antenna, which is varied from 1-4 meters, and the EUT is placed on a turntable, which is 0.8 meter above ground plane, the table shall be rotated for 360 degrees to find out the highest emission. The receiving antenna should be changed the polarization both of horizontal and vertical.

The spectrum analyzer or receiver is set as:

Below 1000MHz:

$$\text{RBW} = 100 \text{ kHz} / \text{VBW} = 300 \text{ kHz} / \text{Sweep} = \text{Auto}$$

Above 1000MHz:

- (1) Peak: RBW = 1MHz / VBW = 1MHz / Sweep = Auto
- (2) Average: RBW = 1MHz / VBW = 10Hz / Sweep = Auto

8.6 Corrected Amplitude & Margin Calculation

The Corrected Amplitude is calculated by adding the Antenna Factor and Cable Factor, and subtracting the Amplifier Gain from the Amplitude reading. The basic equation is as follows:

$$\text{Corrected Amplitude} = \text{Indicated Reading} + \text{Antenna Factor} + \text{Cable Factor} - \text{Amplifier Gain}$$

The “**Margin**” column of the following data tables indicates the degree of compliance with the applicable limit. For example, a margin of -7dB means the emission is 7dB below the maximum limit.

The equation for margin calculation is as follows:

$$\text{Margin} = \text{Corrected Amplitude} - \text{Limit}$$

8.7 Environmental Conditions

Temperature:	28.5 °C
Relative Humidity:	45 %
ATM Pressure:	102.7 kPa

*The testing was performed by Choon Sian Ooi on 2007-11-20.

8.8 Summary of Test Results

According to the data hereinafter, the EUT complied with the applicable FCC Rules and IC Standards, and had the worst margin readings of:

Low Channel:

Mode: Data Transmit			
Margin (dB)	Frequency (MHz)	Polarization (Horizontal/Vertical)	Range (MHz)
-2.8	956.108750	Vertical	30 to 1000
Margin (dB)	Frequency (MHz)	Polarization (Horizontal/Vertical)	Range (MHz)
-21.96	1000	Vertical	1000 to 1500
Margin (dB)	Frequency (MHz)	Polarization (Horizontal/Vertical)	Range (MHz)
-4.72	2800.124	Vertical	1500 to 10000

Middle Channel:

Mode: Data Transmit			
Margin (dB)	Frequency (MHz)	Polarization (Horizontal/Vertical)	Range (MHz)
-2.9	861.836250	Vertical	30 to 1000
Margin (dB)	Frequency (MHz)	Polarization (Horizontal/Vertical)	Range (MHz)
-23.22	1022.711	Vertical	1000 to 1500
Margin (dB)	Frequency (MHz)	Polarization (Horizontal/Vertical)	Range (MHz)
-5.74	2847.862	Vertical	1500 to 10000

High Channel:

Mode: Data Transmit			
Margin (dB)	Frequency (MHz)	Polarization (Horizontal/Vertical)	Range (MHz)
-6.4	874.082500	Vertical	30 to 1000
Margin (dB)	Frequency (MHz)	Polarization (Horizontal/Vertical)	Range (MHz)
-24.77	1047.179	Vertical	1000 to 1500
Margin (dB)	Frequency (MHz)	Polarization (Horizontal/Vertical)	Range (MHz)
-4.6	2799.931	Vertical	1500 to 10000

8.9 Radiated Spurious Emissions Test Data

Low channel

30 to 1000 MHz

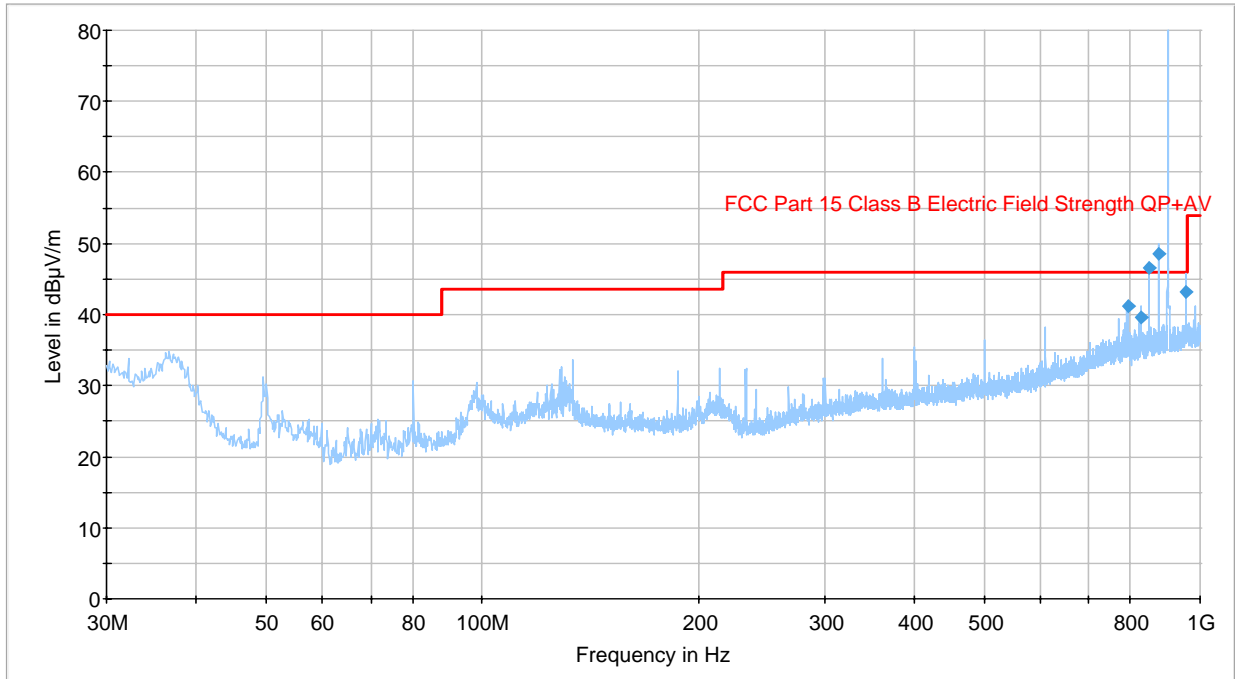

Frequency (MHz)	Quasi-Peak (dBµV/m)	Antenna Height (cm)	Polarity (H/V)	Turntable Position (deg)	Limit (dBµV/m)	Margin (dB)
956.108750	43.2	100.8	V	169.0	46.0	-2.8
795.633750	41.2	100.8	V	307.0	46.0	-4.8
829.281250	39.5	101.0	V	342.0	46.0	-6.5
*875.841250	48.5	100.8	V	6.0	97.15	-48.65
*849.105000	46.6	100.9	V	350.0	97.15	-50.55

*97.15 dBuV/m limit is fundamental field strength 127.15 dBuV/m – 30dBc

1000 to 1500 MHz

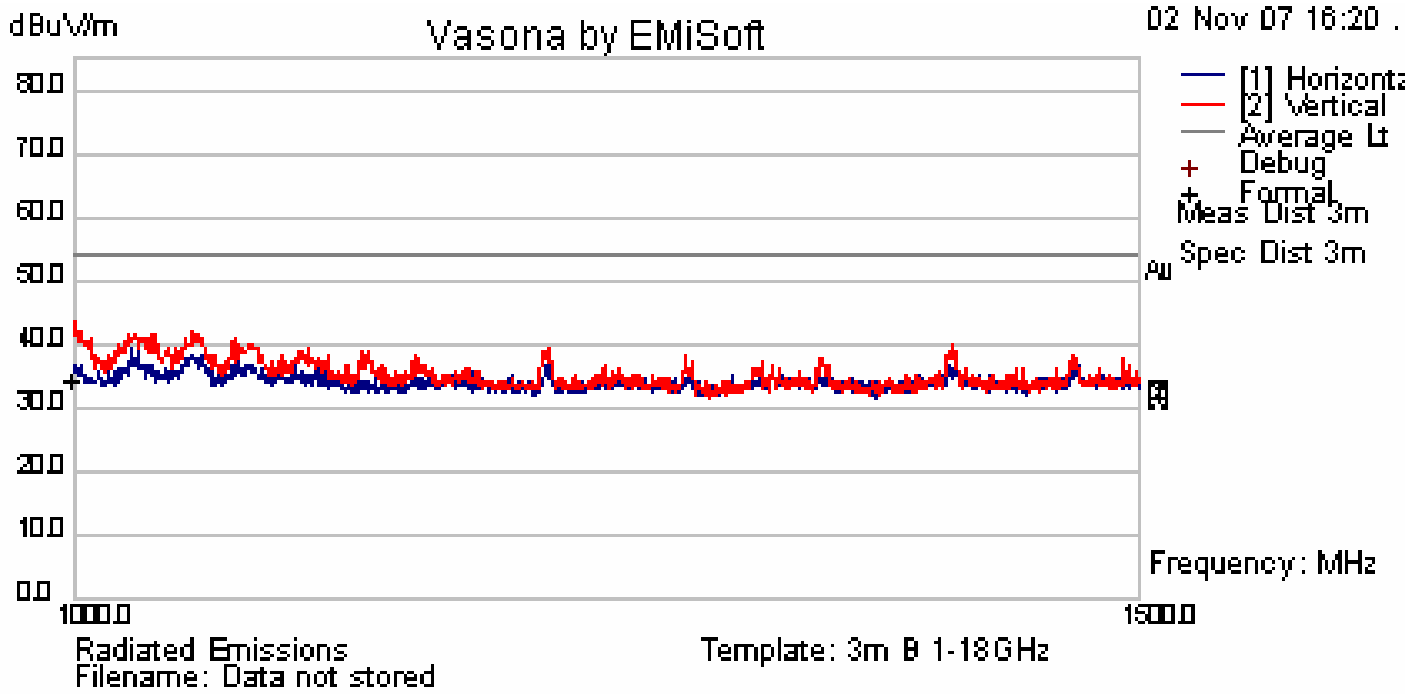

Freq. (MHz)	Cable Loss (dB)	AF (dB)	Level (dBuV/m)	Measurement Type	Pol. (H/V)	Hgt (cm)	Azt Deg	Limit (dBuV/m)	Margin (dB)
1000	1.49	-14.06	32.04	Average Max	V	98	29	54	-21.96

1500 to 10000 MHz

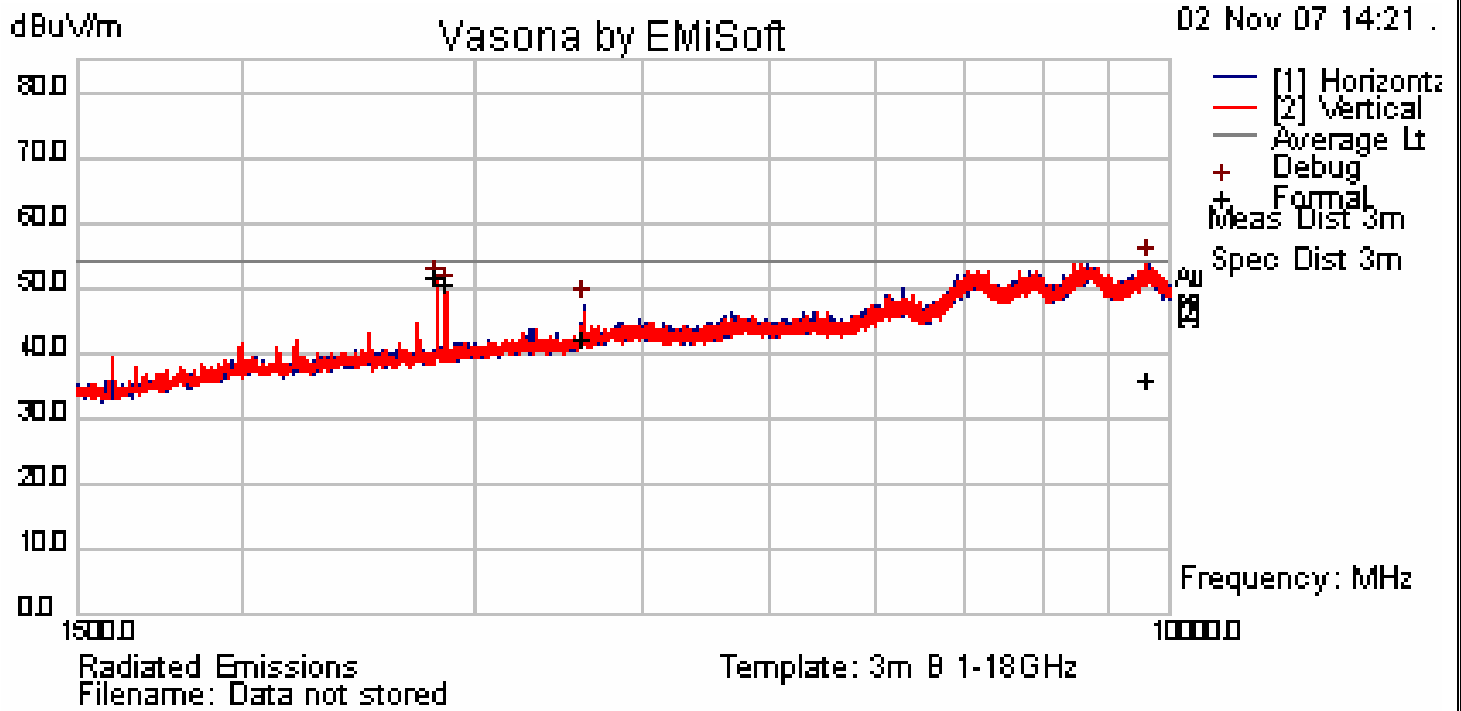

Freq. (MHz)	Cable Loss (dB)	AF (dB)	Level (dBuV/m)	Measurement Type	Pol. (H/V)	Hgt (cm)	Azt Deg	Limit (dBuV/m)	Margin (dB)
2800.124	2.4	-7.03	49.28	Average Max	V	98	33	54	-4.72
2847.797	2.42	-6.88	48.07	Average Max	V	114	36	54	-5.93
3610.444	2.73	-5.38	39.89	Average Max	H	116	281	54	-14.11
9632.762	4.68	1.74	33.4	Average Max	H	268	105	54	-20.6

Middle channel

30 to 1000 MHz

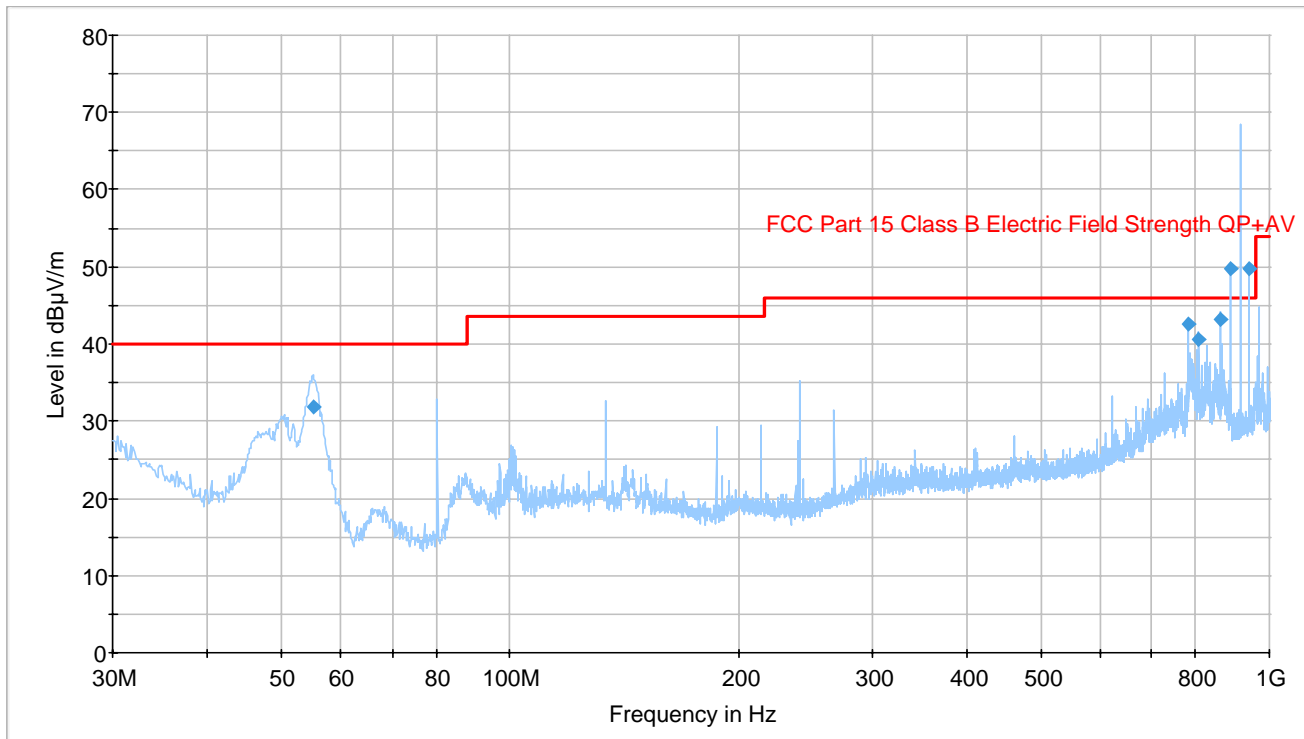

Frequency (MHz)	Quasi-Peak (dBµV/m)	Antenna Height (cm)	Polarity (H/V)	Turntable Position (deg)	Limit (dBµV/m)	Margin (dB)
861.836250	43.1	100.2	V	339.0	46.0	-2.9
781.630000	42.6	100.8	V	288.0	46.0	-3.4
808.365000	40.6	98.2	V	4.0	46.0	-5.4
55.158750	31.9	100.9	V	322.0	40.0	-8.1
*888.632500	49.7	99.9	V	174.0	97.15	-47.45
*942.103750	49.7	142.8	V	24.0	97.15	-47.45

*97.15 dBuV/m limit is fundamental field strength 127.15 dBuV/m – 30dBc

1000 to 1500 MHz

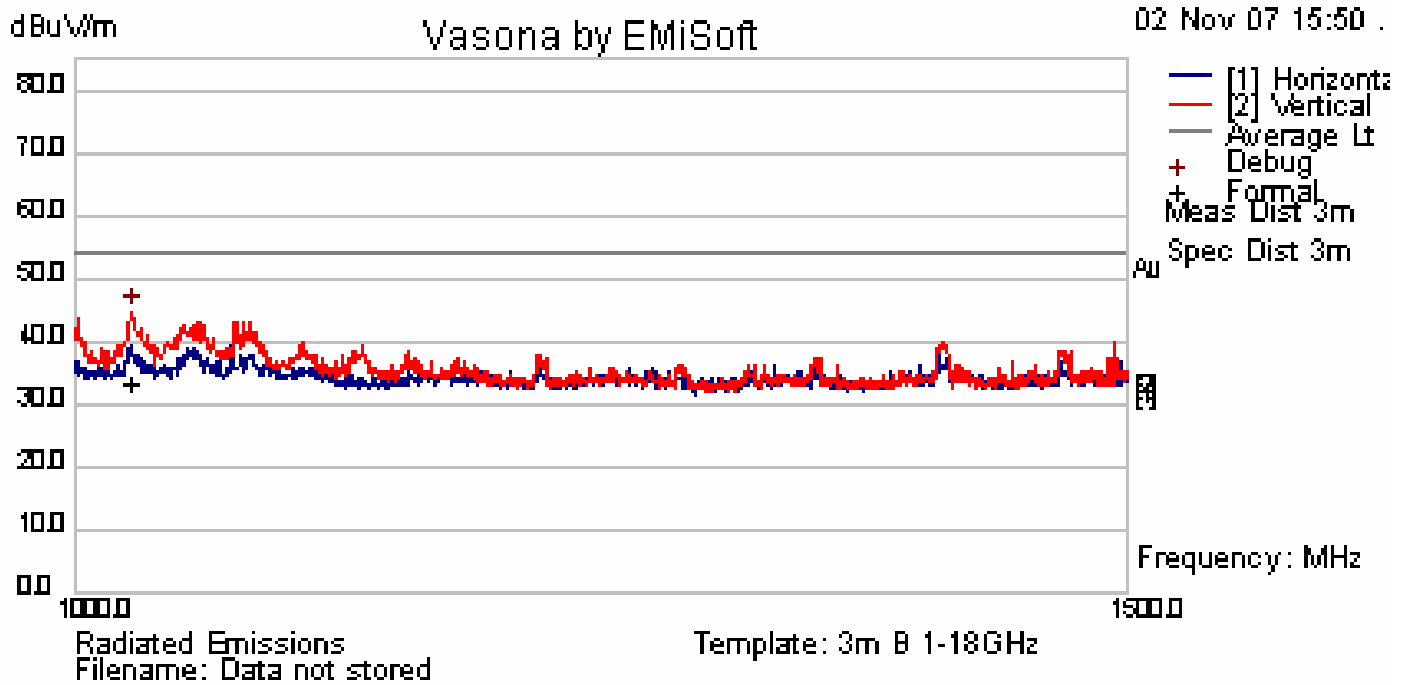

Freq. (MHz)	Cable Loss (dB)	AF (dB)	Level (dBuV/m)	Measurement Type	Pol. (H/V)	Hgt (cm)	Azt Deg	Limit (dBuV/m)	Margin (dB)
1022.711	1.5	-13.99	30.78	Average Max	V	100	12	54	-23.22

1500 to 10000 MHz

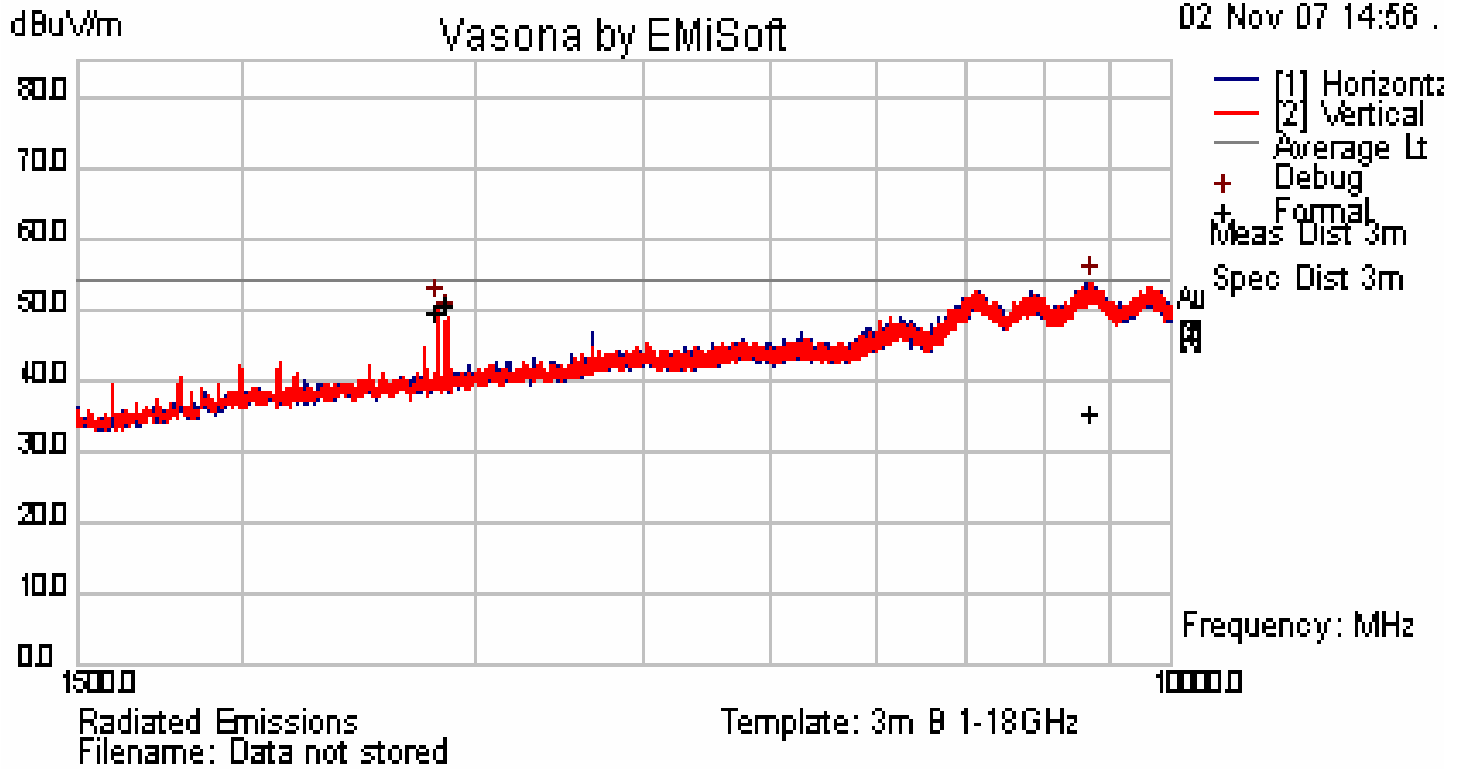

Freq. (MHz)	Cable Loss (dB)	AF (dB)	Level (dBuV/m)	Measurement Type	Pol. (H/V)	Hgt (cm)	Azt Deg	Limit (dBuV/m)	Margin (dB)
2847.862	2.42	-6.88	48.26	Average Max	V	96	33	54	-5.74
2800.054	2.4	-7.03	47.2	Average Max	V	111	34	54	-6.8
8714.542	4.36	1.57	32.93	Average Max	V	134	263	54	-21.07

High channel

30 to 1000 MHz

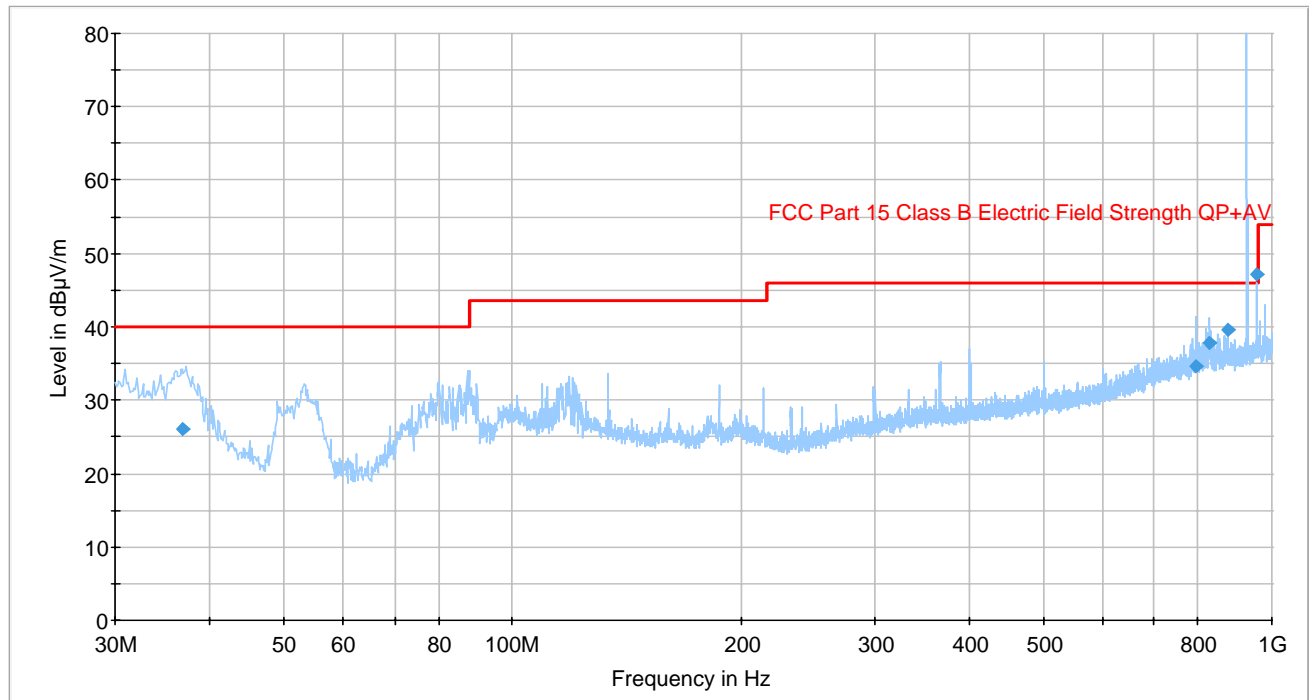

Frequency (MHz)	Quasi-Peak (dBµV/m)	Antenna Height (cm)	Polarity (H/V)	Turntable Position (deg)	Limit (dBµV/m)	Margin (dB)
874.082500	39.6	100.8	V	28.0	46.0	-6.4
829.220000	37.9	101.0	V	339.0	46.0	-8.1
793.815000	34.6	100.8	V	6.0	46.0	-11.4
36.735000	26.0	118.0	V	350.0	40.0	-14.0
*954.350000	47.1	143.0	V	6.0	97.15	-50.05

*97.15 dBuV/m limit is fundamental field strength 127.15 dBuV/m – 30dBc

1000 to 1500 MHz

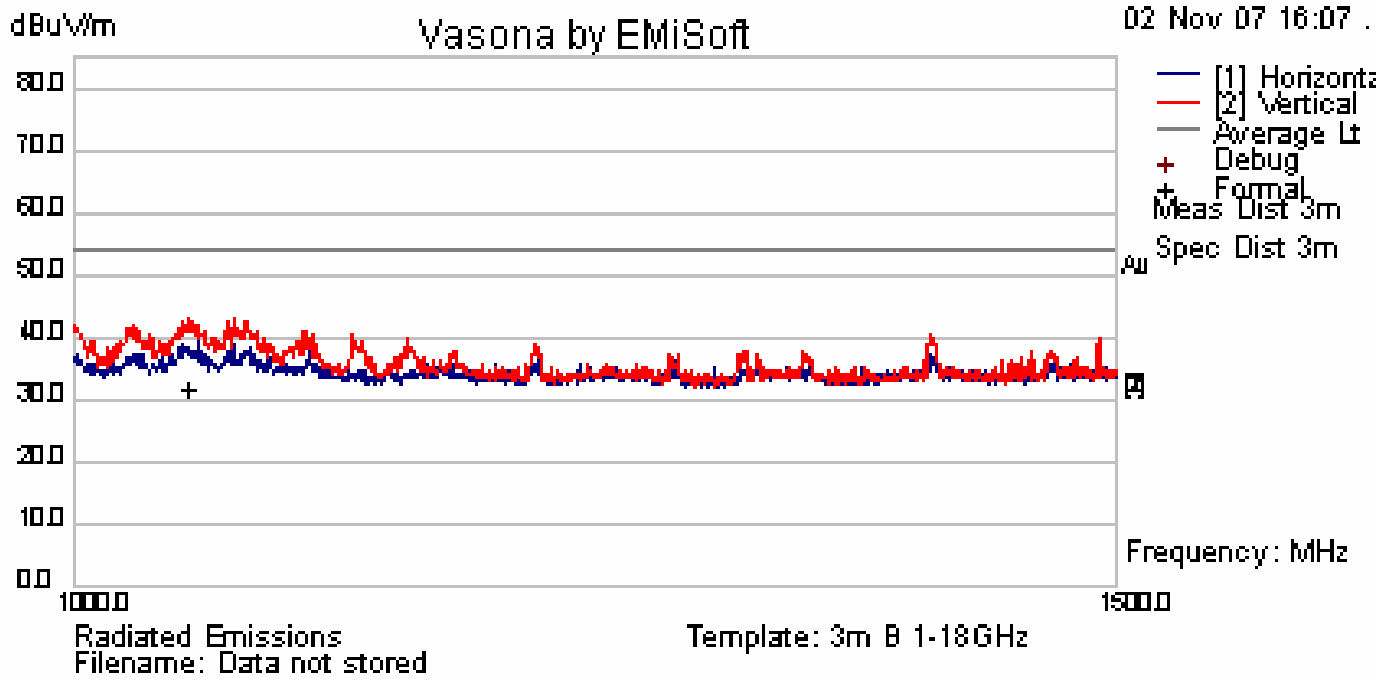

Freq. (MHz)	Cable Loss (dB)	AF (dB)	Level (dBuV/m)	Measurement Type	Pol. (H/V)	Hgt (cm)	Azt Deg	Limit (dBuV/m)	Margin (dB)
1047.179	1.51	-13.92	29.23	Average Max	V	103	170	54	-24.77

1500 to 10000 MHz

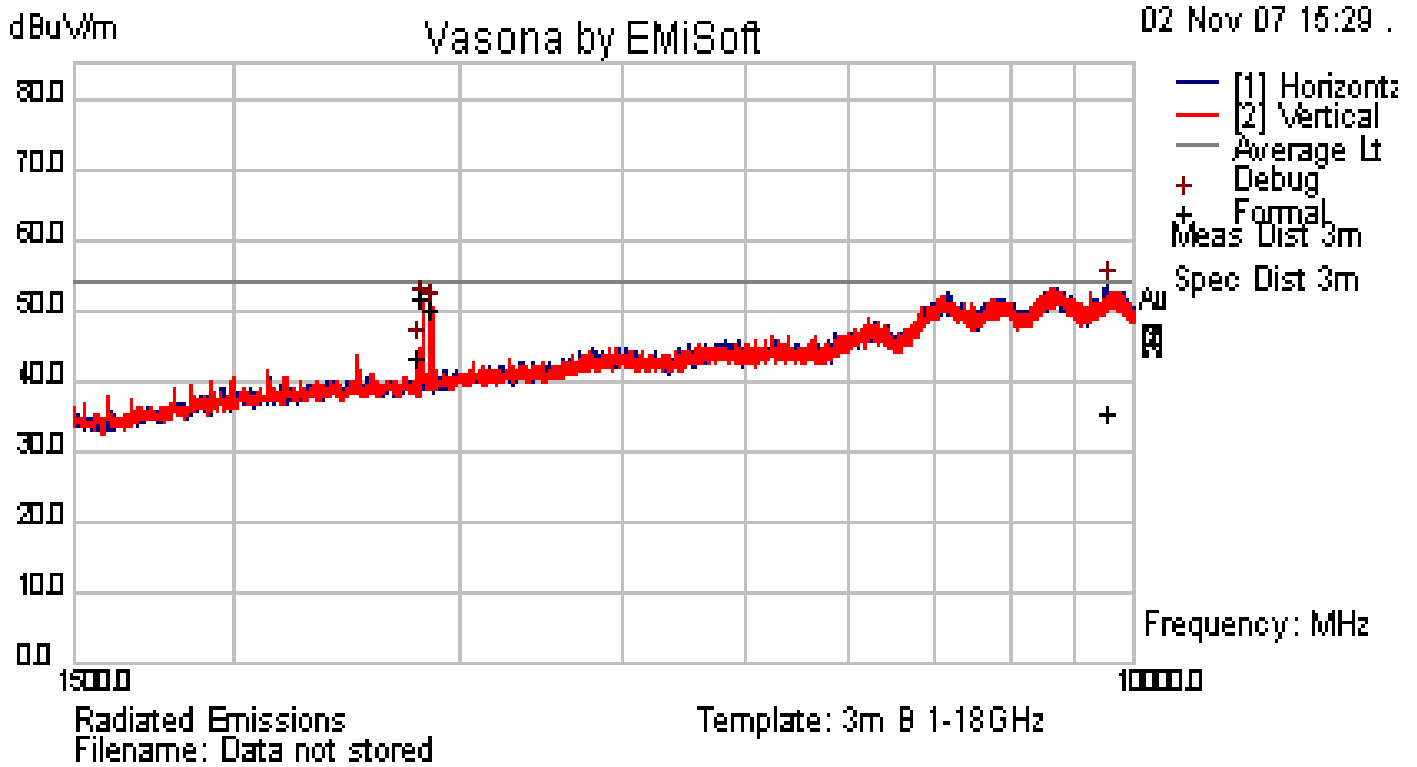

9 RSS-210 § 2.6 Receiver Spurious Radiated Emissions

9.1 Test Setup

The radiated emissions tests were performed in the 3 meter chamber, using the setup in accordance with ANSI C63.4-2003.

9.2 Equipment Lists and Details

Manufacturer	Description	Model	Serial Number	Calibration Date
Agilent	Spectrum Analyzer	E4446A	US44300386	2007-04-26
Sonoma Instrument	Amplifier Broadband (10 kHz - 2500 MHz)	317	260407	2007-04-26
Sunol Science Corp.	30MHz ~ 3 GHz Antenna	JB3	A020106-3/S006628	2007-03-05

Statement of Traceability: BACL Corp. attests that all calibrations have been performed per the NVLAP requirements, traceable to the NIST.

9.3 Environmental Conditions

Temperature:	28.5 °C
Relative Humidity:	45 %
ATM Pressure:	102..7 kPa

**The testing was performed by Choon Sian Ooi on 2007-11-05*

9.4 Test Procedure

Maximizing procedure was performed on the six (6) highest emissions to ensure EUT compliance is with all installation combinations.

All data were recorded in the peak detection mode. Quasi-peak readings was performed only when an emissions was found to be marginal (within -4 dB of specification limits), and are distinguished with a "QP" in the data table.

9.5 Corrected Amplitude & Margin Calculation

The Corrected Amplitude is calculated by adding the Antenna Factor and Cable Factor, and subtracting the Amplifier Gain from the Amplitude reading. The basic equation is as follows:

$$\text{Corrected Amplitude} = \text{Indicated Reading} + \text{Antenna Factor} + \text{Cable Factor} - \text{Amplifier Gain}$$

The "**Margin**" column of the following data tables indicates the degree of compliance with the applicable limit. For example, a margin of -7dB means the emissions are 7dB below the maximum limit for Class B. The equation for margin calculation is as follows:

$$\text{Margin} = \text{Corrected Amplitude} - \text{Class B Limit}$$

9.6 Summary of Test Results

According to the test data,, the EUT complied with the with the applicable FCC rules and IC Standards, with the closest margins from the limit listed below:

Radiated Emissions Test Data @ 3meter

-4.12 dB at 133.77 MHz in the Horizontal polarization

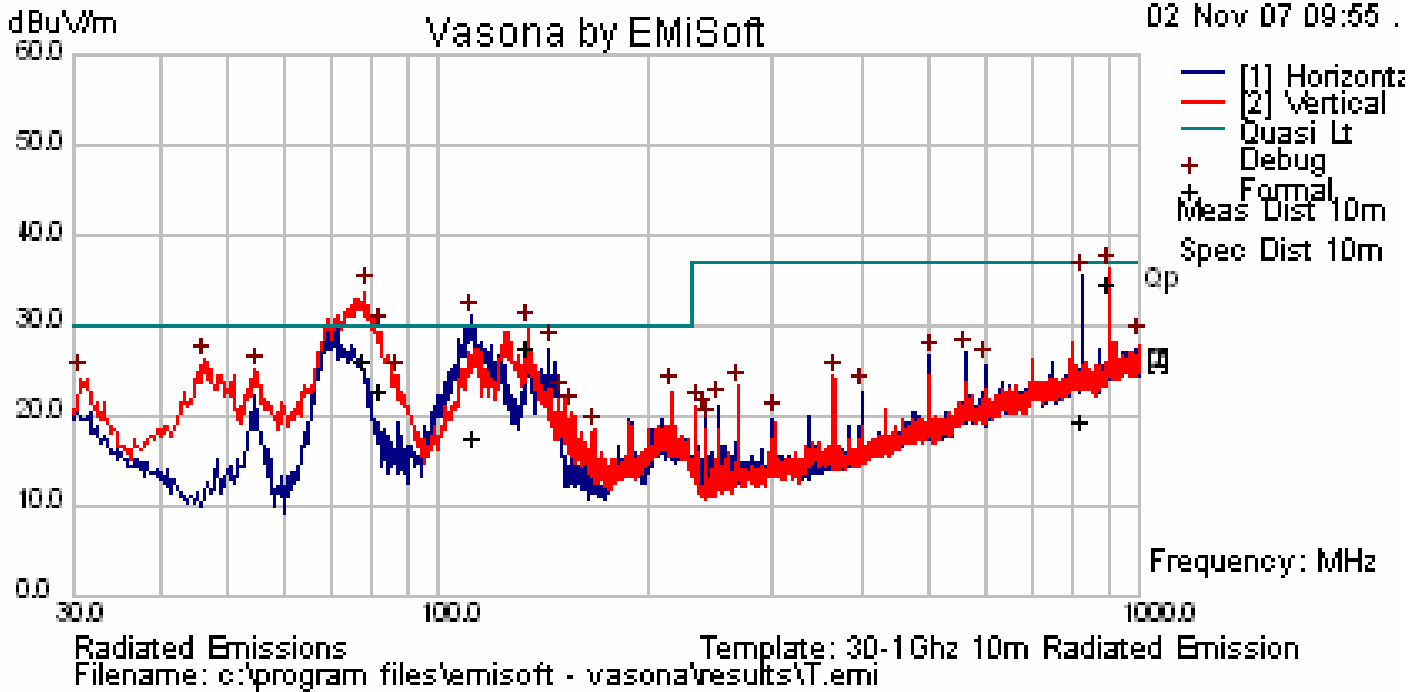

Quasi-Peak Measurements

Frequency (MHz)	Quasi-Peak (dBµV/m)	Antenna Height (cm)	Polarity (H/V)	Turntable Position (degrees)	Limit (dBµV/m)	Margin (dB)
133.77	25.88	H	359	275	30	-4.12
902.602	32.8	V	113	2	37	-4.2
78.078	24.21	V	380	25	30	-5.79
82.844	20.91	V	180	276	30	-9.09
111.647	15.91	H	180	278	30	-14.09
830.199	17.72	H	279	281	37	-19.28

10 FCC §15.247(a) (1), RSS-210 § A8.1(c) – 20 dB Bandwidth & 99% Bandwidth

10.1 Applicable Standard

According to §15.247(a)(1)(i) and RSS-210 §A8.1 (c), The maximum allowed 20 dB bandwidth of the hopping channel is 500 kHz.

10.2 Measurement Procedure

1. Check the calibration of the measuring instrument using either an internal calibrator or a known signal from an external generator.
2. Position the EUT without connection to measurement instrument. Turn on the EUT and connect it to measurement instrument. Then set it to any one convenient frequency within its operating range. Set a reference level on the measuring instrument equal to the highest peak value.
3. Measure the frequency difference of two frequencies that were attenuated 6 dB from the reference level. Record the frequency difference as the emissions bandwidth. (6 dB bandwidth for DTS)
4. Repeat above procedures until all frequencies measured were complete.

10.3 Equipment List

Manufacturer	Description	Model	Serial Number	Calibration Date
Agilent	Spectrum Analyzer	E4446A	US44300386	2007-04-26

* **Statement of Traceability:** **BACL Corp.** attests that all calibrations have been performed per the NVLAP requirements, traceable to the NIST.

10.4 Environmental Conditions

Temperature:	28.5 °C
Relative Humidity:	45 %
ATM Pressure:	102..7 kPa

*The testing was performed by Choon Sian Ooi on 2007-11-28.

10.5 Summary of Test Results

Channel	20 dB Channel Bandwidth (kHz)	99% Channel Bandwidth (kHz)
Low	398.445	389.4943
Middle	394.890	392.2335
High	399.210	400.5802

Please refer to the following plots for detailed test results

Low Channel

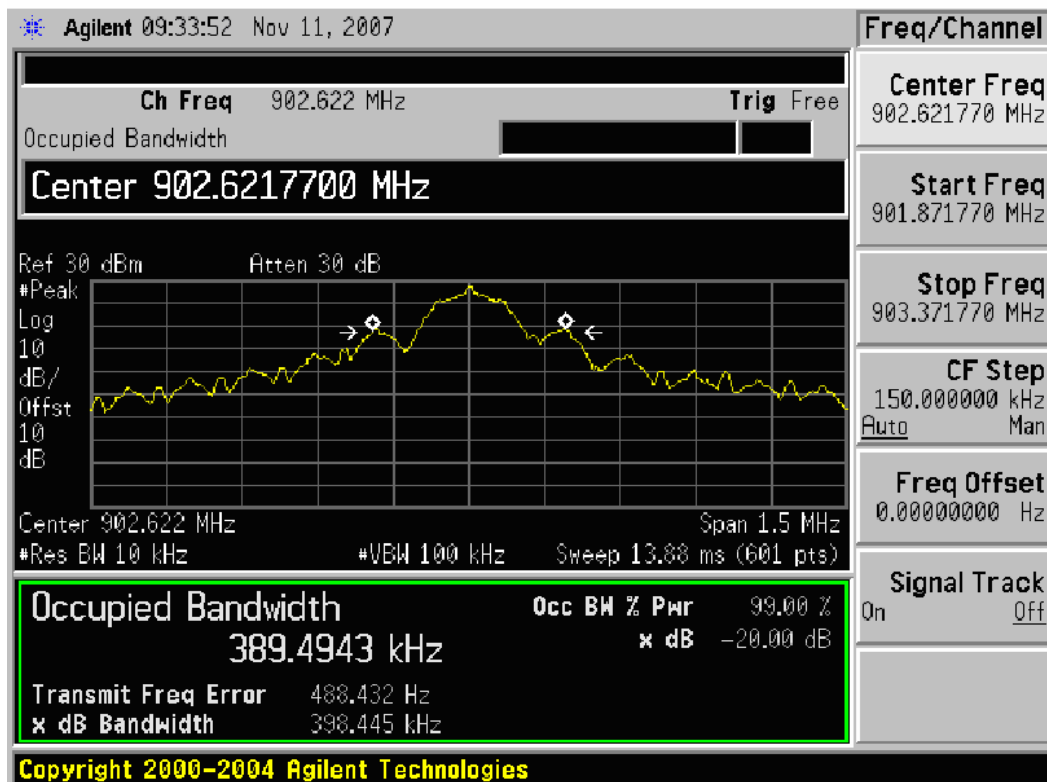

Middle Channel

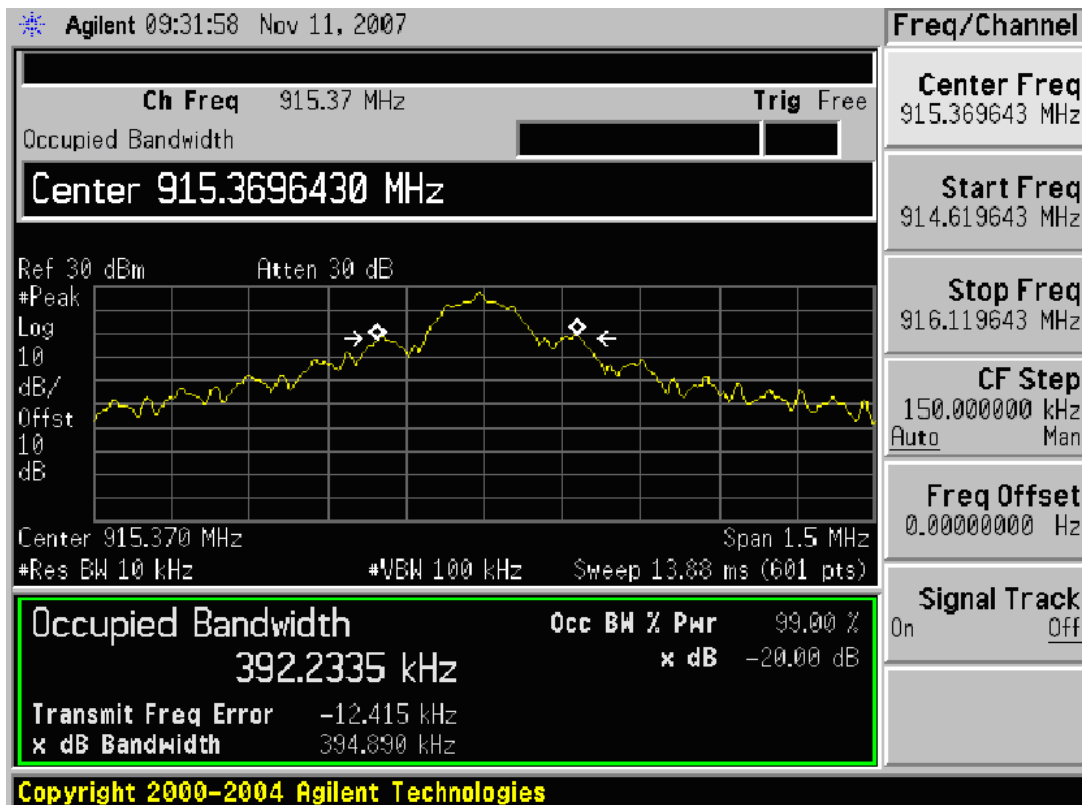

High Channel

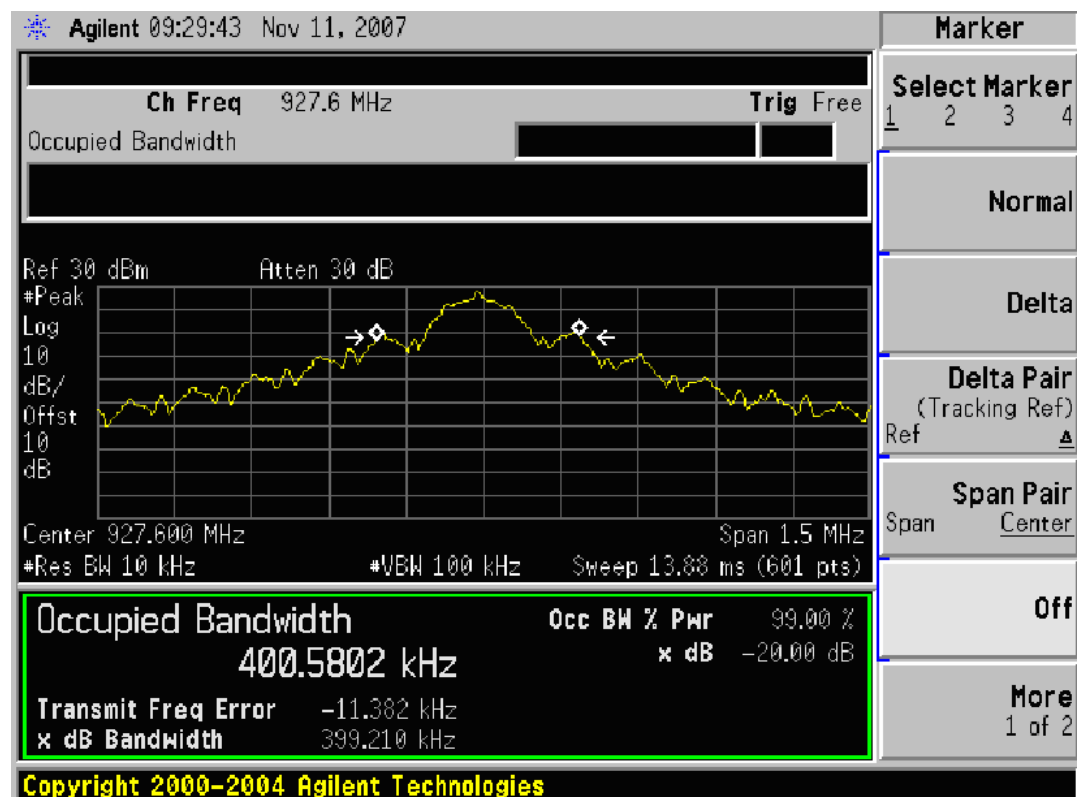

11 §15.247 (a) (1) & RSS-210 §A8.1 (b) – Hopping Channel Separation

11.1 Applicable Standard

According to §15.247(a)(1) and RSS-210 §A8.1 (b), frequency hopping system shall have, hopping channel carrier frequencies separated by a minimum of 25 kHz or the 20 dB bandwidth of the hopping channel, whichever is greater. The system shall hop to channel frequencies that are selected at the system hopping rate from a pseudo randomly ordered list of hopping frequencies.

11.2 Measurement Procedure

1. Check the calibration of the measuring instrument (SA) using either an internal calibrator or a known signal from an external generator.
2. Position the EUT on a bench without connection to measurement instrument Turn on the EUT and connect it to measurement instrument. Then set it to any one convenient frequency within its operating range.
3. By using the Max-Hold function record the separation of two adjacent channels.
4. Measure the frequency difference of these two adjacent channels by SA MARK function, and then plot the result on SA screen.
5. Repeat above procedures until all frequencies measured were complete.

11.3 Test Equipment

Manufacturer	Description	Model Number	Serial Number	Calibration Date
Agilent	Spectrum Analyzer	E4446A	US44300386	2007-04-26

* **Statement of Traceability:** **BACL Corp.** attests that all calibrations have been performed per the NVLAP requirements, traceable to the NIST.

11.4 Test Setup Diagram

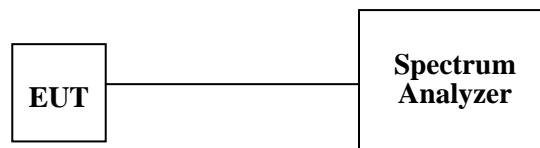

11.5 Environmental Conditions

Temperature:	28.5 °C
Relative Humidity:	45 %
ATM Pressure:	102.7 kPa

*The testing was performed by Choon Sian Ooi on 2007-11-28.

11.6 Measurement Results

Channel	Channel Separation (kHz)	Limit > 20 dB BW >(kHz)	Result
Low	511	398.445	Compliant
Middle	511	394.890	Compliant
High	511	399.210	Compliant

Please refer to the following plots:

Low Channel

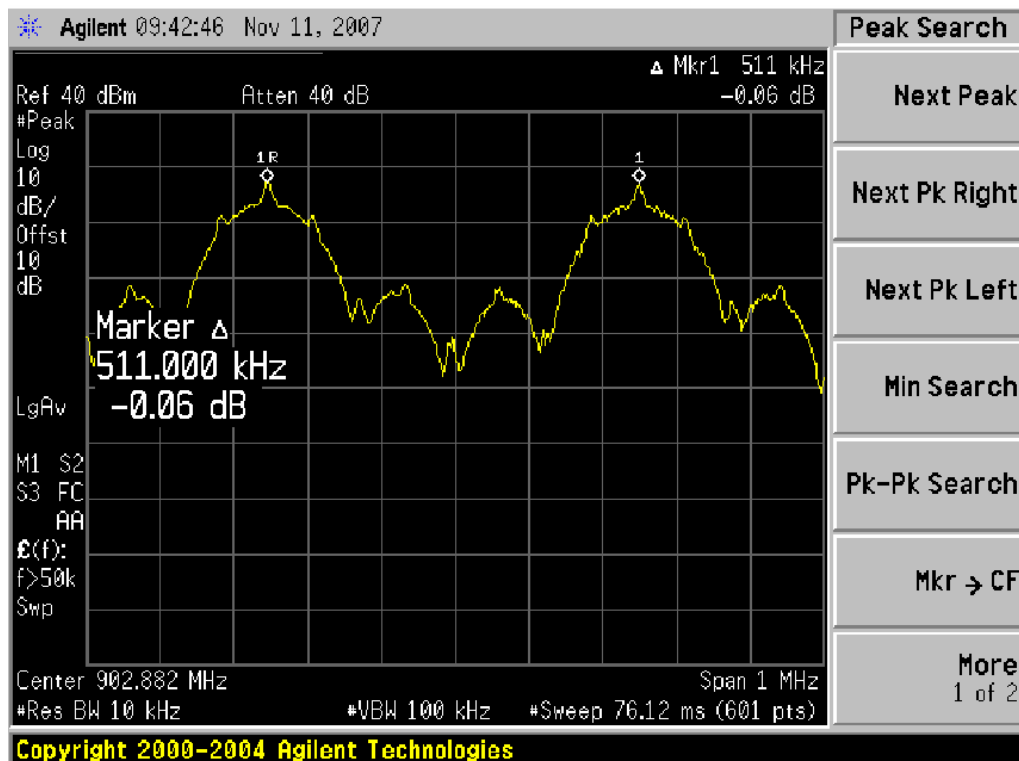

Middle Channel

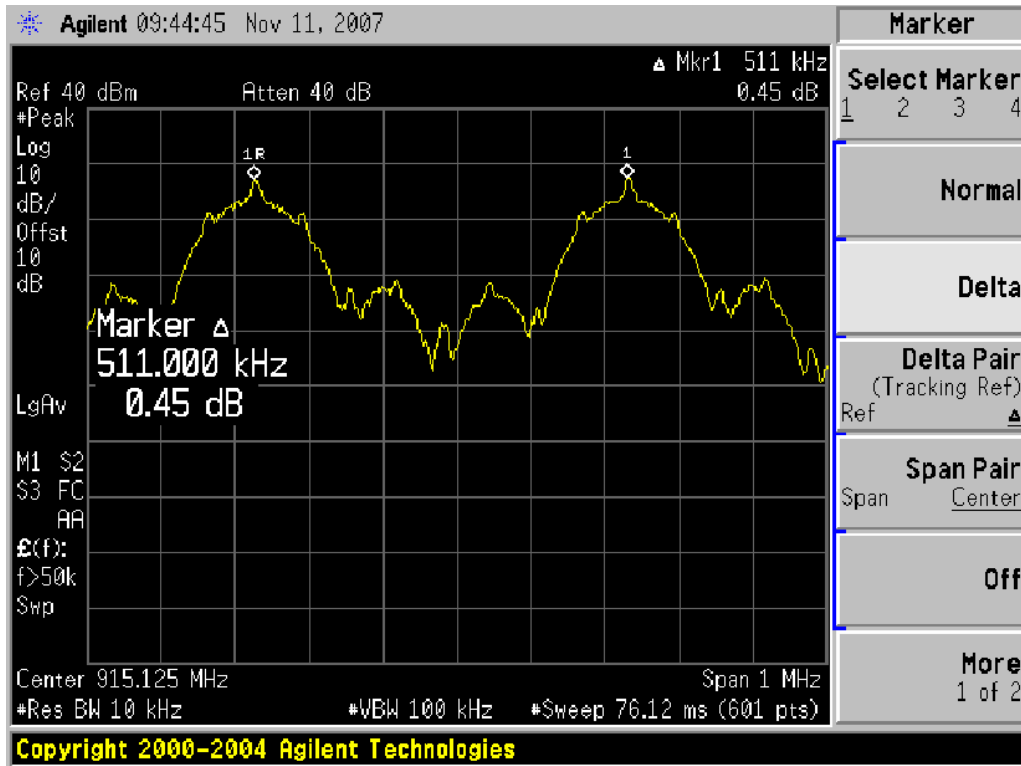

High Channel

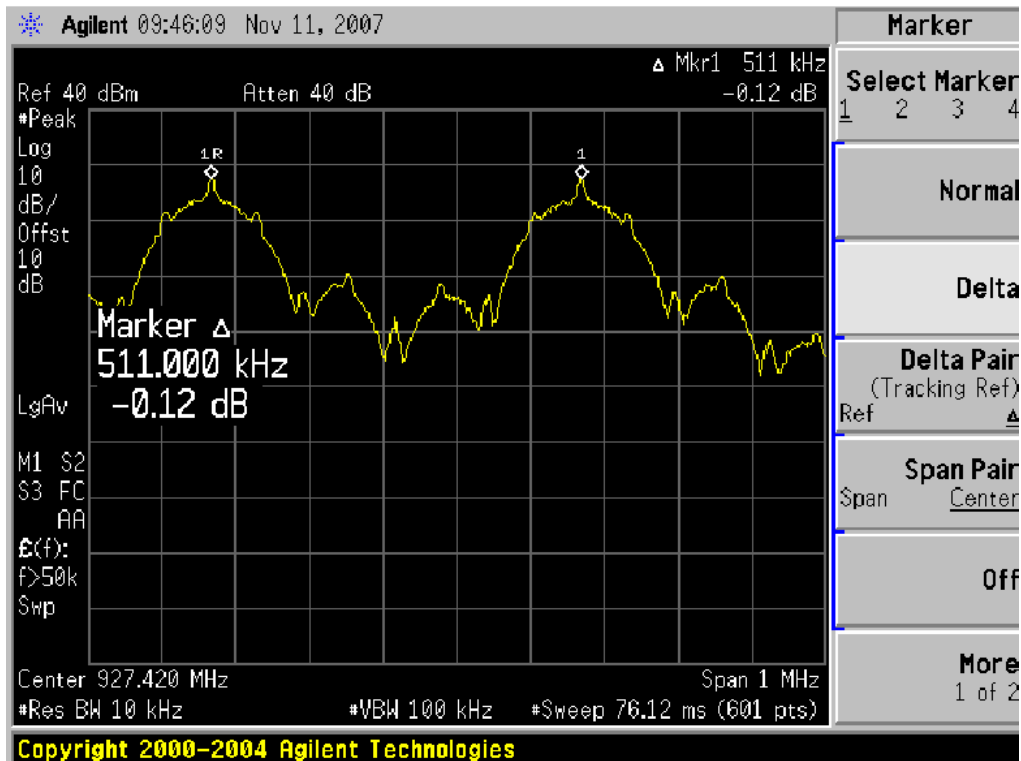

12 FCC §15.247(b) (2), RSS210 § A8.4 - Peak Output Power Measurement

12.1 Applicable Standard

The maximum peak output power of the intentional radiator shall not exceed the following:

§15.247(b) (2) and RSS210 §A8.4 (1): for frequency hopping systems employing at least 50 hopping channels in the 902–928 MHz band: 1 Watt.

12.2 Measurement Procedure

1. Place the EUT on a bench and set it in transmitting mode.
2. Remove the antenna from the EUT and then connect a low loss RF cable from the antenna port to a spectrum analyzer.
3. Add a correction factor to the display.
4. Spectrum analyzer settings:

Span = approximately 5 times the 20 dB bandwidth, centered on a hopping channel

RBW > the 20 dB bandwidth of the emission being measured

VBW ≥ RBW

Sweep = auto

Detector function = peak

Trace = max hold

Allow the trace to stabilize. Use the marker-to-peak function to set the marker to the peak of the emission. The indicated level is the peak output power (see the NOTE above regarding external attenuation and cable loss). The limit is specified in one of the subparagraphs of this Section. Submit this plot. A peak responding power meter may be used instead of a spectrum analyzer.

12.3 Equipment List

Manufacturer	Description	Model	Serial Number	Calibration Date
Agilent	Spectrum Analyzer	E4446A	US44300386	2007-04-26

* **Statement of Traceability: BACL Corp.** attests that all calibrations have been performed per the NVLAP requirements, traceable to the NIST.

12.4 Environmental Conditions

Temperature:	28.5 °C
Relative Humidity:	45 %
ATM Pressure:	102.7 kPa

**The testing was performed by Choon Sian Ooi on 2007-11-28*

12.5 Measurement Result

Channel	Max Peak Output Power		Limit (mW)	Result
	(dBm)	(mW)		
Low	29.66	924.698	1000	Compliant
Mid	29.37	864.967	1000	Compliant
High	28.81	760.326	1000	Compliant

Please see the following plots:

Low Channel

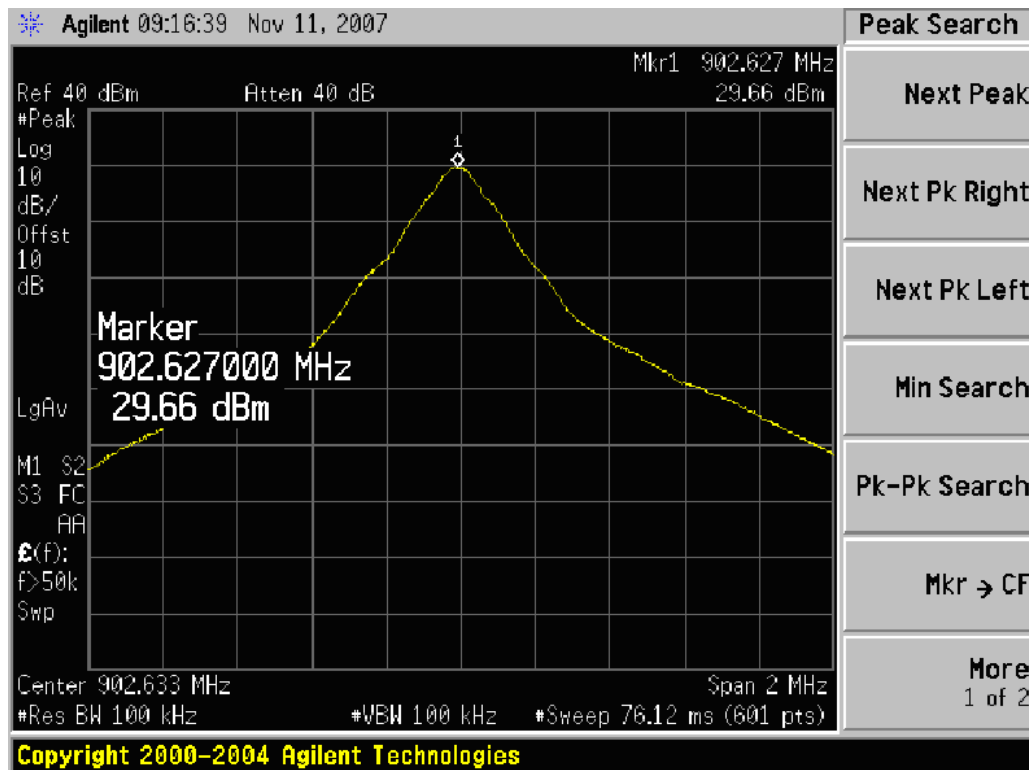

Middle Channel

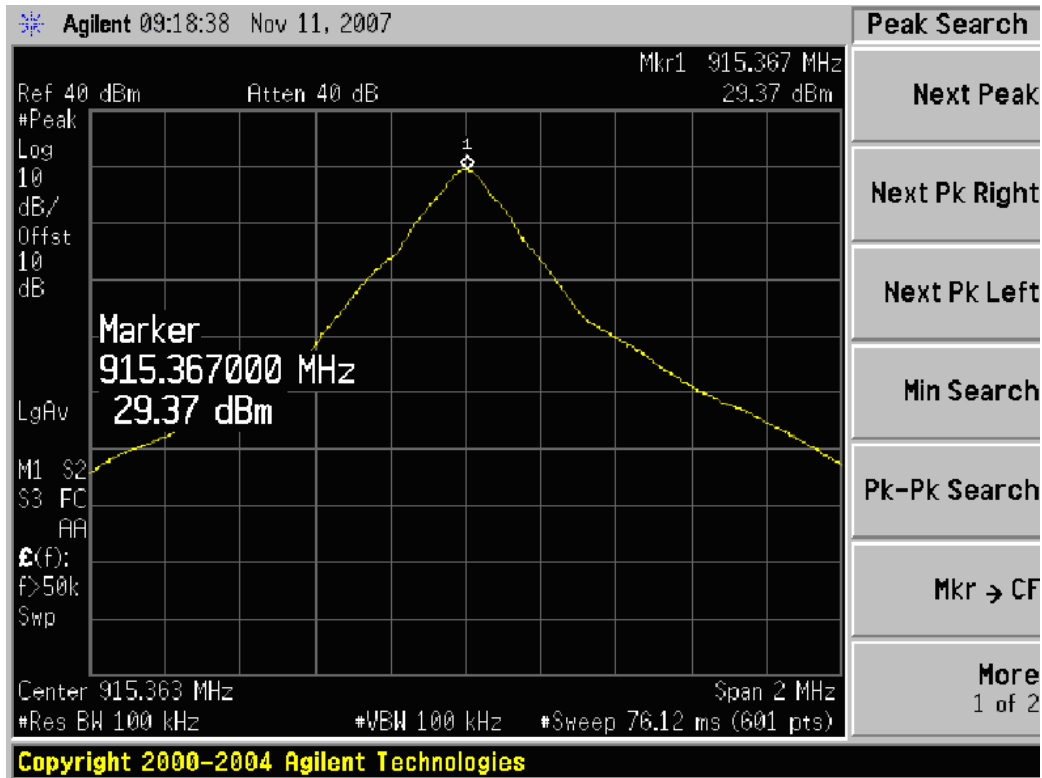

High Channel

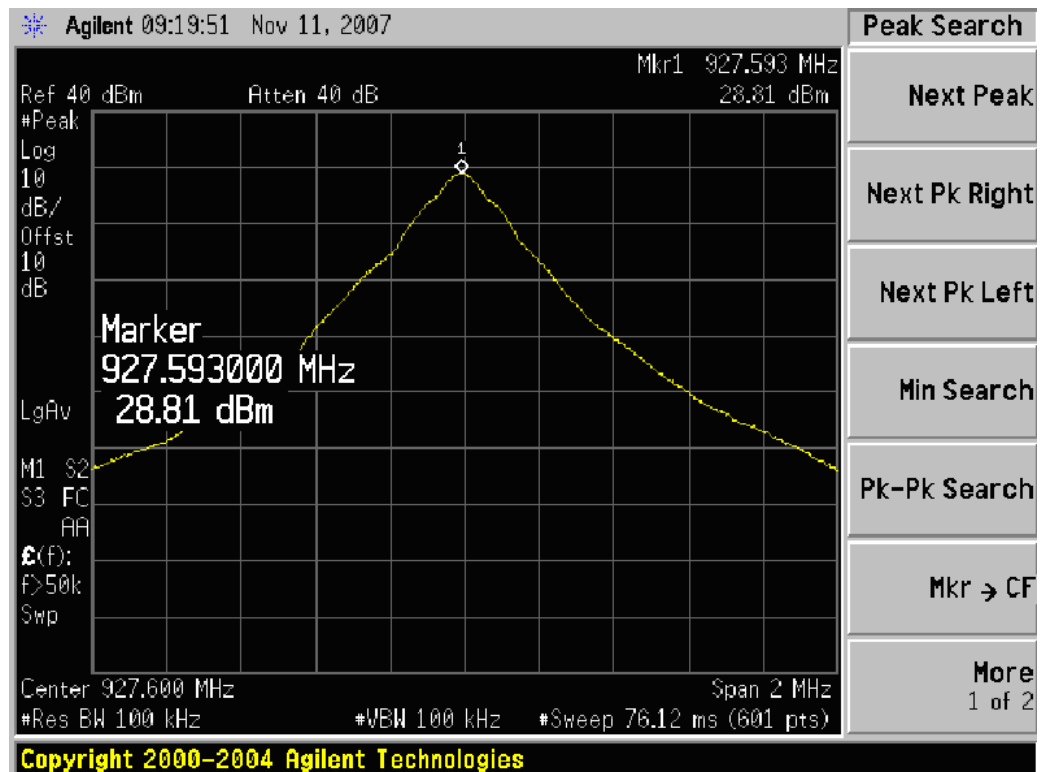

13 §15.247(a)(1)(i) & RSS-210 § A8.1 (c) - Number of Hopping Frequencies Used

13.1 Standard Applicable

According to §15.247(a)(1)(i) and RSS-210 §A8.1 (c), For frequency hopping systems operating in the 902–928 MHz band: if the 20 dB bandwidth of the hopping channel is less than 250 kHz, the system shall use at least 50 hopping frequencies and the average time of occupancy on any frequency shall not be greater than 0.4 seconds within a 20 second period; if the 20 dB bandwidth of the hopping channel is 250 kHz or greater, the system shall use at least 25 hopping frequencies and the average time of occupancy on any frequency shall not be greater than 0.4 seconds within a 10 second period.

13.2 Measurement Procedure

1. Check the calibration of the measuring instrument (SA) using either an internal calibrator or a known signal from an external generator.
2. Position the EUT on the bench without connection to measurement instrument. Turn on the EUT and connect its antenna terminal to measurement instrument via a low loss cable. Then set it to any one measured frequency within its operating range, and make sure the instrument is operated in its linear range.
3. Set the SA on Max-Hold Mode, and then keep the EUT in hopping mode. Record all the signals from each channel until each one has been recorded.
4. Set the SA on View mode and then plot the result on SA screen.
5. Repeat above procedures until all frequencies measured were complete.

13.3 Test Equipment List and Details

Manufacturer	Description	Model Number	Serial Number	Calibration Date
Agilent	Spectrum Analyzer	E4446A	US44300386	2007-04-26

* **Statement of Traceability:** **BACL Corp.** attests that all calibrations have been performed per the NVLAP requirements, traceable to the NIST.

13.4 Test Setup Diagram

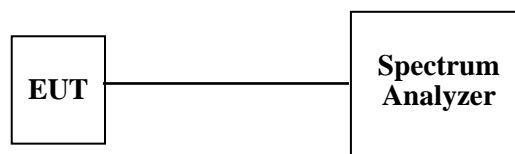

13.5 Environmental Conditions

Temperature:	28 °C
Relative Humidity:	42 %
ATM Pressure:	102.0 kPa

**The testing was performed by Choon Sian Ooi on 2007-11-28*

13.6 Measurement Result

Frequency Range (MHz)	Number of Hopping Channels	Limit
902-928	50	>15

Please refer to the following plots:

Plot-1: Number of Channels: 27

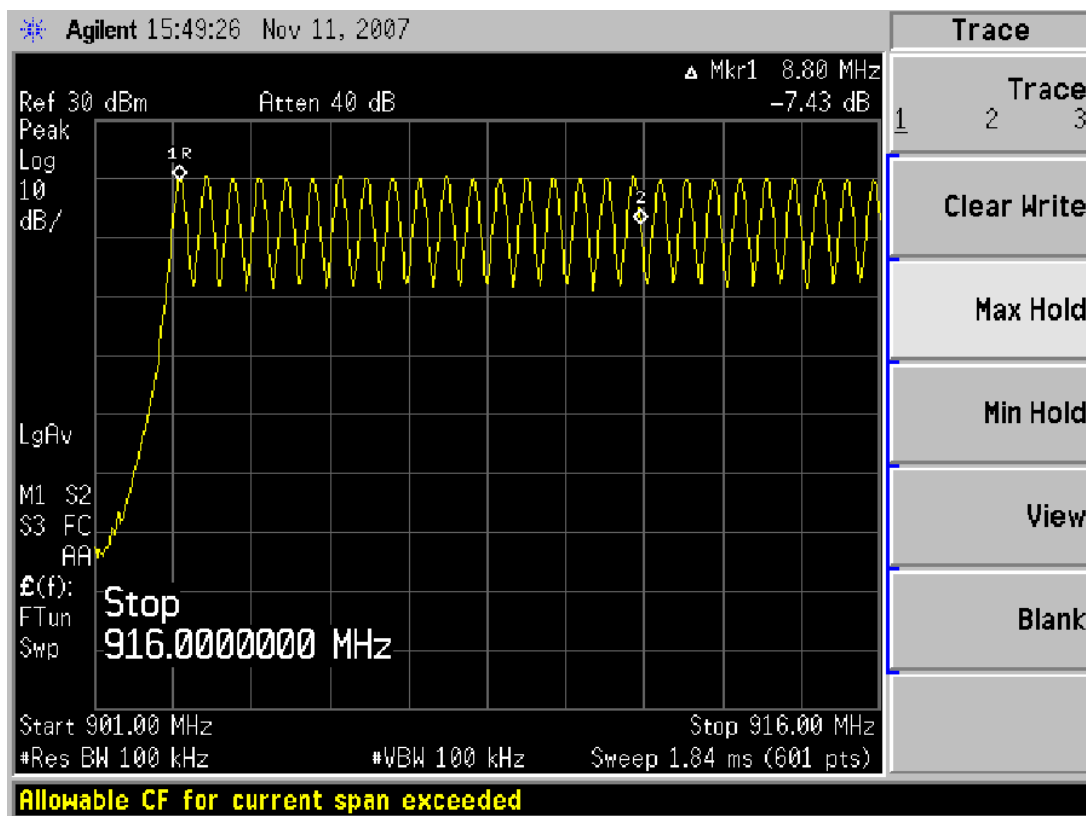

Plot-2: Number of Channels: 23

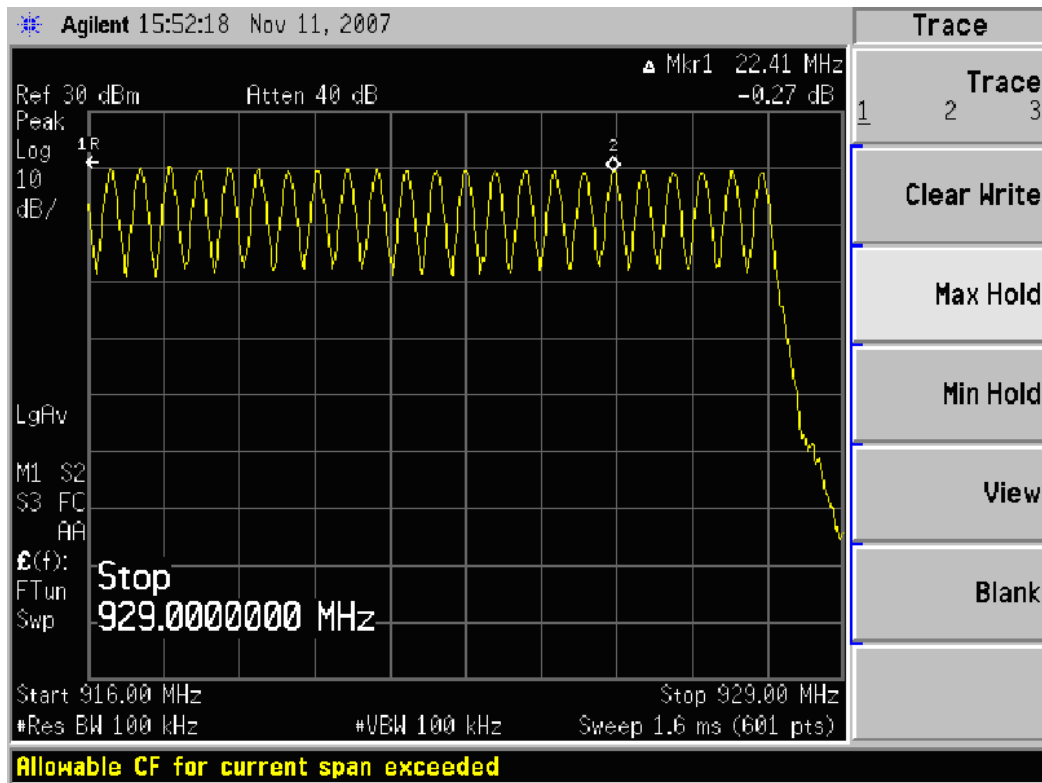

14 §15.247(a) (1) (i), RSS-210 §A8.1 (c) - Dwell Time

14.1 Applicable Standard

According to §15.247 (a)(1)(i) and RSS-210 §A8.1 (c), For frequency hopping systems operating in the 902–928 MHz band: if the 20 dB bandwidth of the hopping channel is less than 250 kHz, the system shall use at least 50 hopping frequencies and the average time of occupancy on any frequency shall not be greater than 0.4 seconds within a 20 second period; if the 20 dB bandwidth of the hopping channel is 250 kHz or greater, the system shall use at least 25 hopping frequencies and the average time of occupancy on any frequency shall not be greater than 0.4 seconds within a 10 second period.

14.2 Measurement Procedure

1. Check the calibration of the measuring instrument using either an internal calibrator or a known signal from an external generator.
2. Position the EUT was set without connection to measurement instrument. Turn on the EUT and connect its antenna terminal to measurement instrument via a low loss cable. Then set it to any one measured frequency within its operating range, and make sure the instrument is operated in its linear range.
3. Adjust the center frequency of SA on any frequency be measured and set SA to zero span mode. And then, set RBW and VBW of spectrum analyzer to proper value.
4. Measure the time duration of one transmission on the measured frequency. And then plot the result with time difference of this time duration.
5. Repeat above procedures until all frequencies measured were complete.

14.3 Test Equipment List and Details

Manufacturer	Description	Model Number	Serial Number	Calibration Date
Agilent	Spectrum Analyzer	E4446A	US44300386	2007-04-26

* **Statement of Traceability:** **BACL Corp.** attests that all calibrations have been performed per the NVLAP requirements, traceable to the NIST.

14.4 Test Setup Diagram

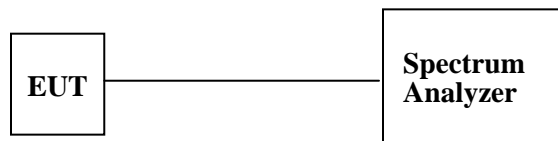

14.5 Environmental Conditions

Temperature:	28.5 °C
Relative Humidity:	45 %
ATM Pressure:	102.7 kPa

**The testing was performed by Choon Sian Ooi on 2007-11-28*

14.6 Measurement Results

Channel	Pulse Width (ms)	Pulse Quantity Per 20 Sec	Dwell Time (sec.)	Limit (Sec.)	Result
Low	45.6496	3	0.136949	0.4	Compliant
Mid	46.0928	3	0.138278	0.4	Compliant
High	45.428	2	0.090856	0.4	Compliant

Please refer the following plots.

Low Channel

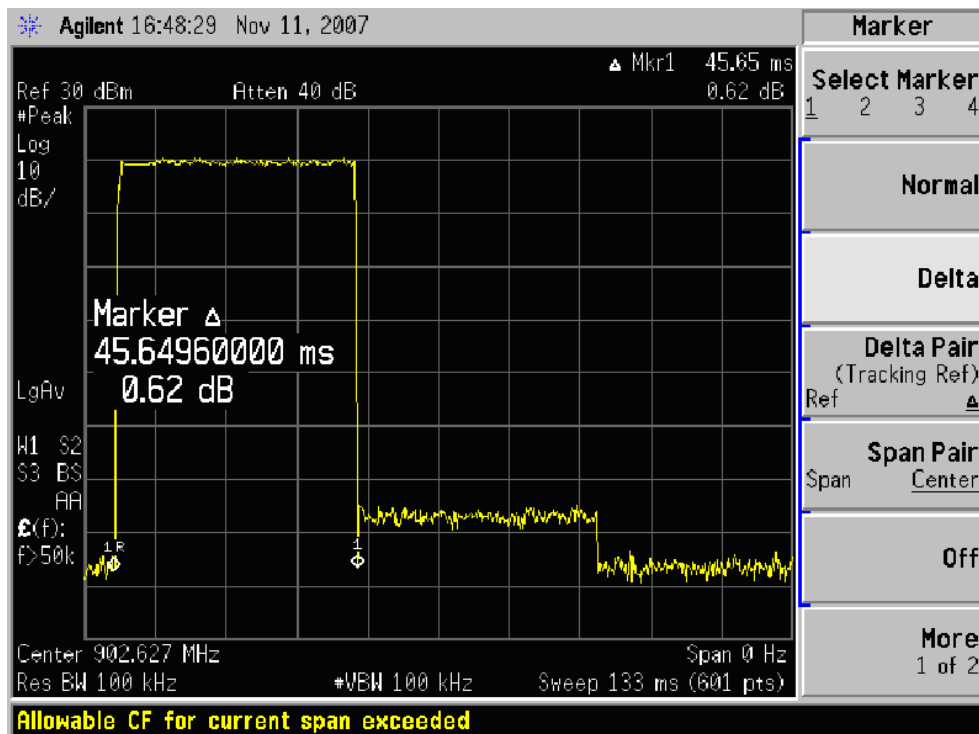
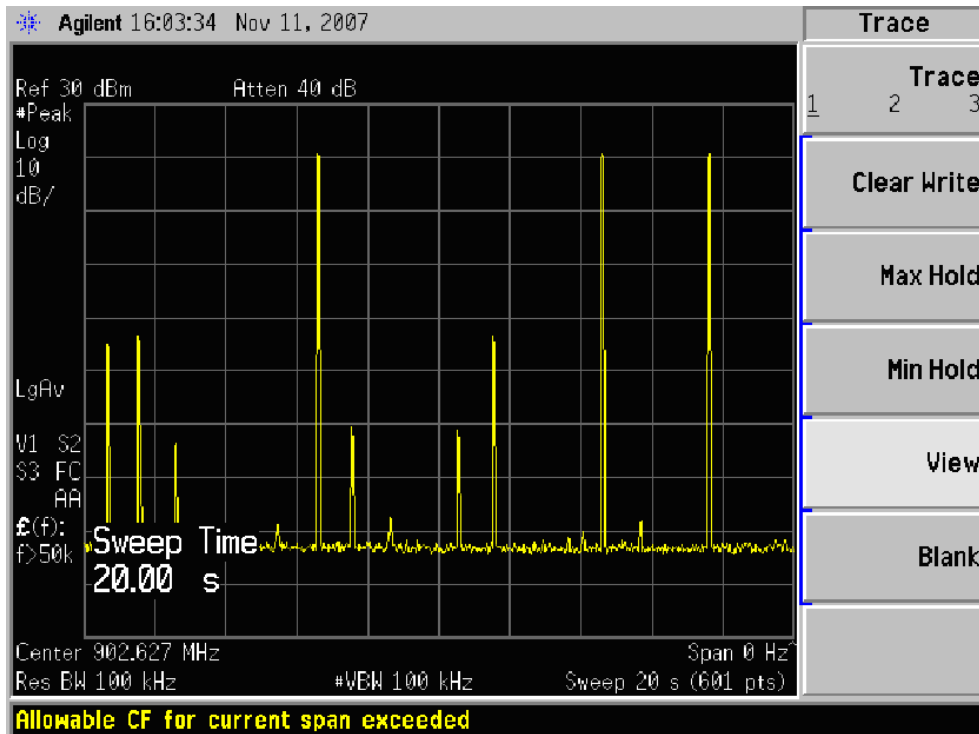

Middle Channel

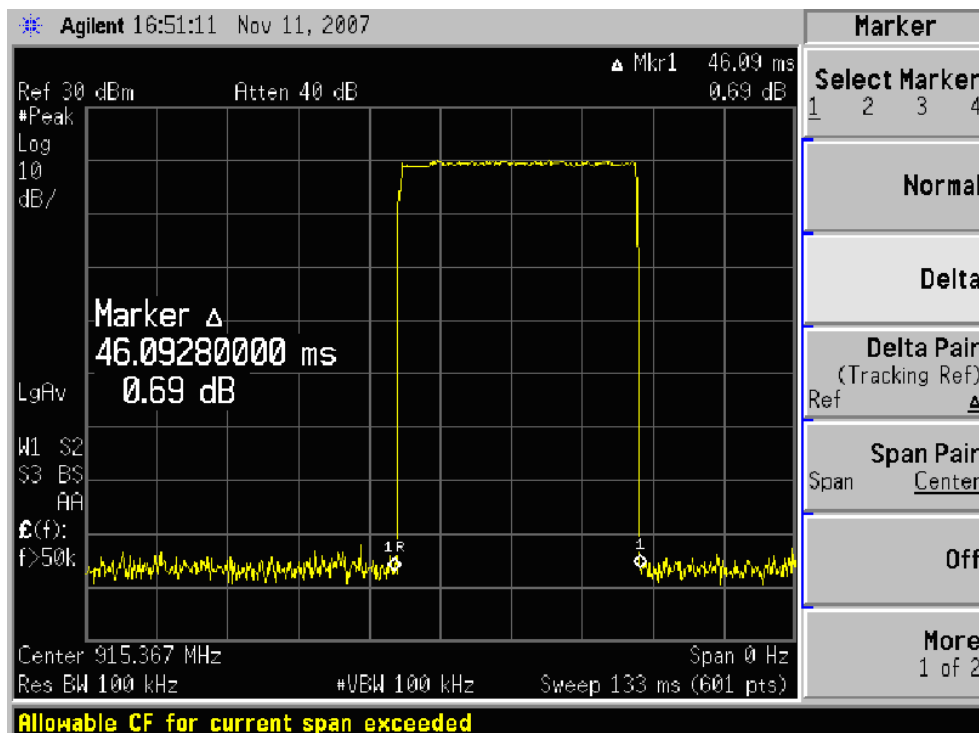
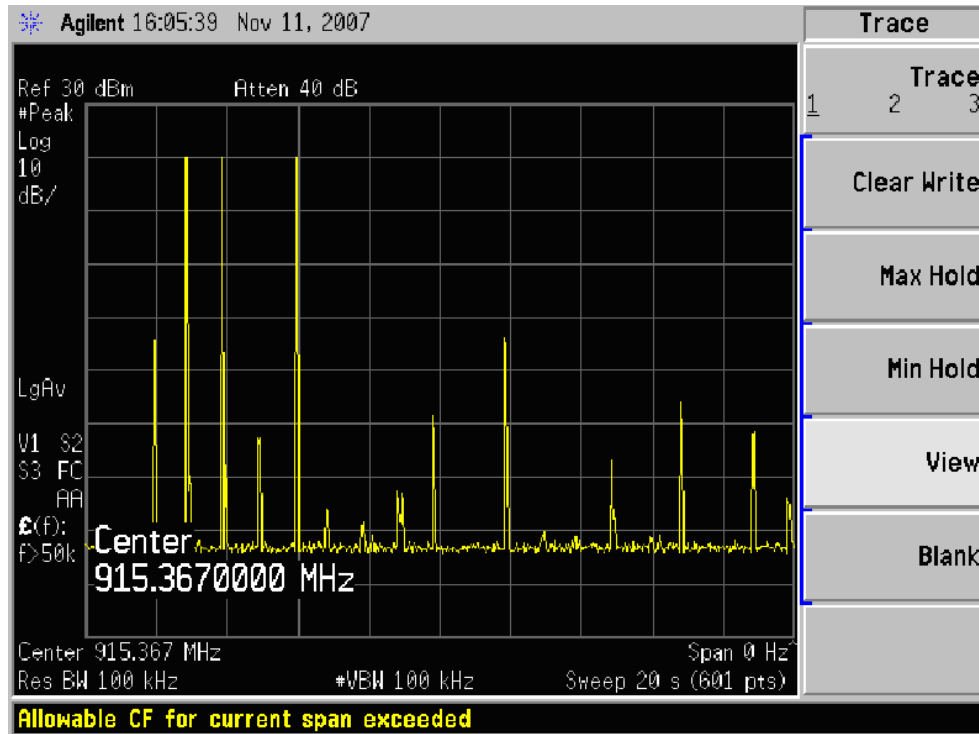

High Channel

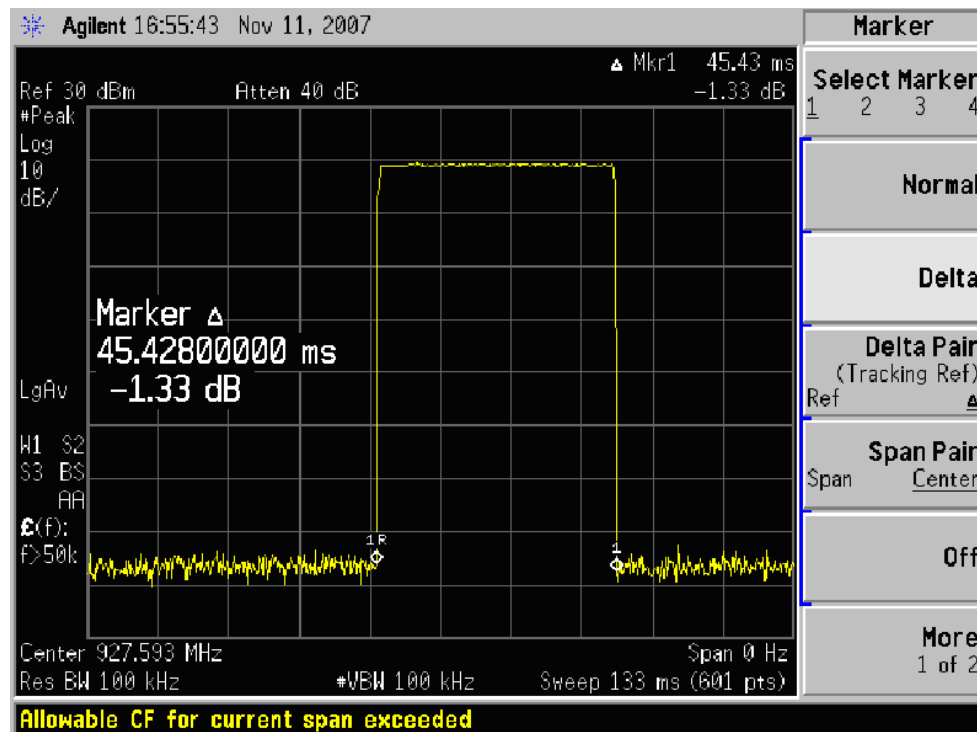
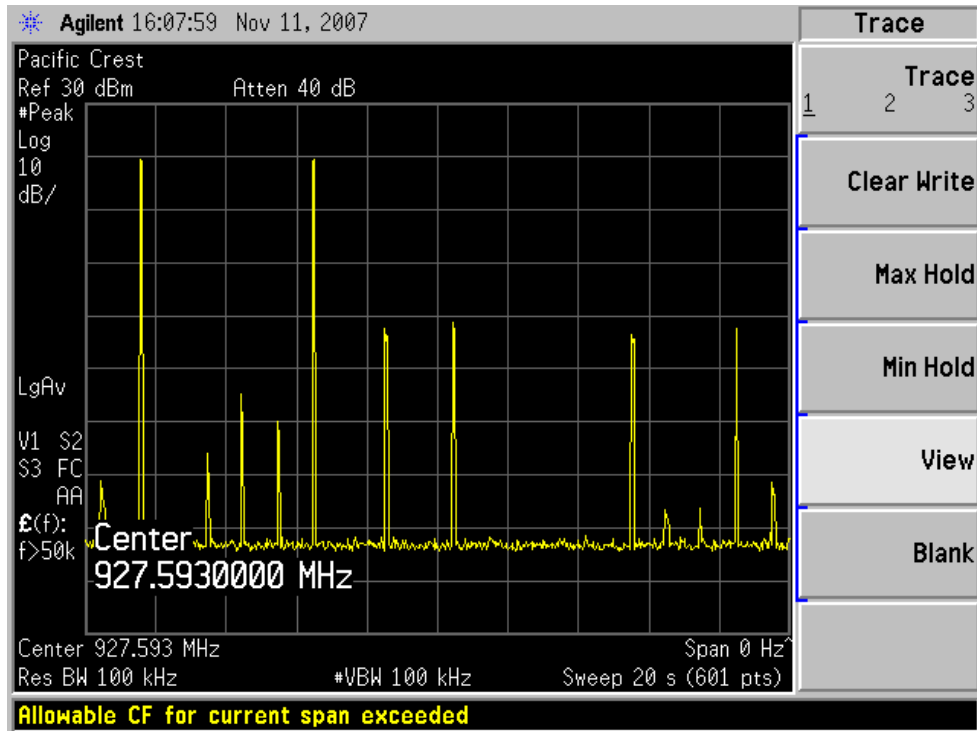

15 FCC §15.247(d), RSS-210 § A8.5 - 100 kHz Bandwidth of Band Edges

15.1 Applicable Standard

According to §15.247(d), in *any* 100 kHz bandwidth outside the frequency bands in which the spread spectrum intentional radiator is operating, the radio frequency power that is produced by the intentional radiator shall be at least 20 dB below that in the 100 kHz bandwidth within the band that contains the highest level of the desired power, based on either an RF conducted or a radiated measurement. In addition, radiated emissions which fall in the restricted bands, as defined in §15.205(a), must also comply with the radiated emissions limits specified in §15.209(a) see §15.205(c).

RSS210§ A8.5: In any 100 kHz bandwidth outside the frequency band in which the spread spectrum or digitally modulated device is operating, the radio frequency power that is produced shall be at least 20 dB below that in the 100 kHz bandwidth within the band that contains the highest level of the desired power, based on either an RF conducted or a radiated measurement, provided the transmitter demonstrates compliance with the peak conducted power limits. If the transmitter complies with the conducted power limits based on the use of RMS averaging over a time interval, as permitted under section A8.4(4), the attenuation required shall be 30 dB instead of 20 dB. Attenuation below the general limits specified in Tables 2 and 3 is not required. In addition, radiated emissions which fall in the restricted bands of Table 1 must also comply with the radiated emissions limits specified in Tables 2 and 3.

15.2 Measurement Procedure

1. Check the calibration of the measuring instrument using either an internal calibrator or a known signal from an external generator.
2. Position the EUT without connection to measurement instrument. Turn on the EUT and connect its antenna terminal to measurement instrument via a low loss cable. Then set it to any one measured frequency within its operating range, and make sure the instrument is operated in its linear range.
3. Set both RBW and VBW of spectrum analyzer to 100 kHz with a convenient frequency span including 100 kHz bandwidth from band edge.
4. Measure the highest amplitude appearing on spectral display and set it as a reference level. Plot the graph with marking the highest point and edge frequency.
5. Repeat above procedures until all measured frequencies were complete.

15.3 Equipment List

Manufacturer	Description	Model	Serial Number	Calibration Date
Agilent	Spectrum Analyzer	E4446A	US44300386	2007-04-26

* **Statement of Traceability:** **BACL Corp.** attests that all calibrations have been performed per the NVLAP requirements, traceable to the NIST.

15.4 Environmental Conditions

Temperature:	28.5 °C
Relative Humidity:	45 %
ATM Pressure:	102.7 kPa

The testing was performed by Choon Sian Ooi on 2007-11-28

Please Refer to the Following Plots

Low Channel

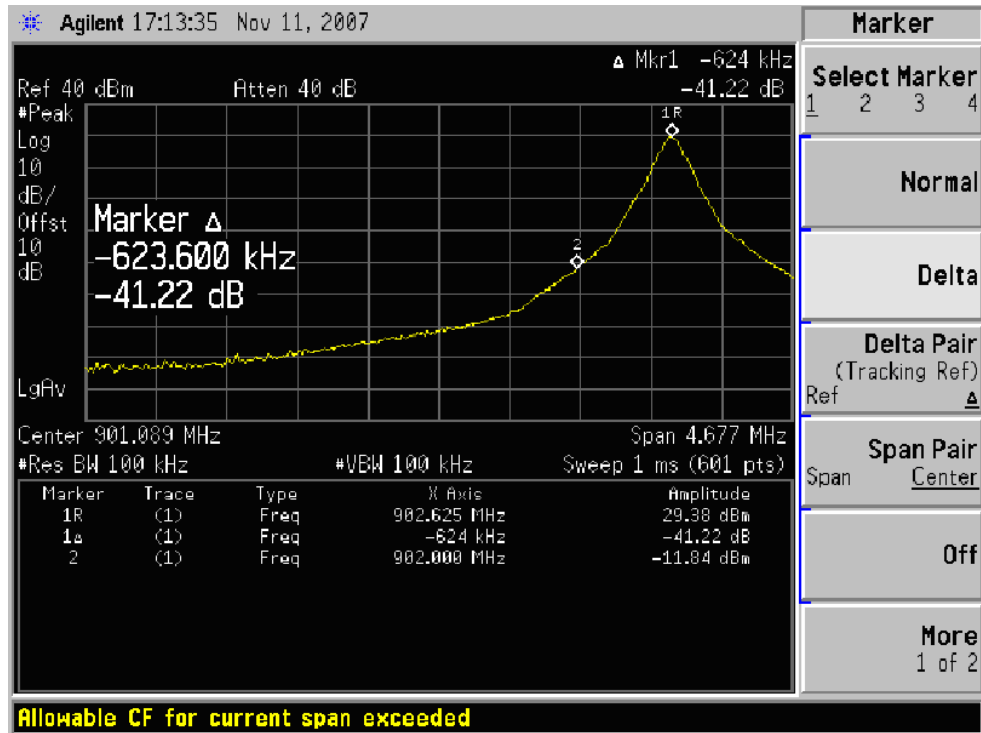

High Channel

