



FCC PART 15.247
INDUSTRY CANADA RSS-210, ISSUE 7, JUNE 2007
MEASUREMENT AND TEST REPORT

For
Trimble Navigation Limited

935 Stewart Drive
Sunnyvale, CA 94085, USA

FCC ID: JUP-5580090
IC: 1756A-5580090

This Report Concerns: <input checked="" type="checkbox"/> Supplemental Report	Equipment Type: GPS Receiver with 900MHz FHSS Transceiver
Test Engineer:	Xiao Ming Hu 
Report Number:	R0805301-247
Report Date:	2008-06-03
Reviewed By:	Boni Baniqued RF Sr. Engineer 
Prepared By: (i0)	Bay Area Compliance Laboratories Corp. (BACL) 1274 Anvilwood Ave. Sunnyvale, CA 94089 Tel: (408) 732-9162 Fax: (408) 732-9164 www.baclcorp.com

Note: This test report is prepared for the customer shown above and for the device described herein. It may not be duplicated or used in part without prior written consent from Bay Area Compliance Laboratories Corp. This report **must not** be used by the customer to claim product certification, approval, or endorsement by NVLAP*, NIST, or any agency of the Federal Government.
* This report may contain data that are not covered by the NVLAP accreditation and are marked with an asterisk "*" en-2

TABLE OF CONTENTS

1	GENERAL INFORMATION	4
1.1	PRODUCT DESCRIPTION FOR EQUIPMENT UNDER TEST (EUT)	4
1.2	MECHANICAL DESCRIPTION	4
1.3	EUT PHOTO	4
1.4	OBJECTIVE	5
1.5	RELATED SUBMITTAL(S)/ GRANT(S)	5
1.6	TEST METHODOLOGY	5
1.7	MEASUREMENT UNCERTAINTY	5
1.8	TEST FACILITY	5
2	SYSTEM TEST CONFIGURATION	7
2.1	JUSTIFICATION	7
2.2	SPECIAL ACCESSORIES	7
2.3	EQUIPMENT MODIFICATIONS	7
2.4	POWER SUPPLY AND LINE FILTERS	7
2.5	INTERNAL CONFIGURATION	7
2.6	LOCAL SUPPORT EQUIPMENT LIST AND DETAILS	7
2.7	INTERFACE PORTS AND CABLING	7
2.8	TEST SETUP BLOCK DIAGRAM	8
3	SUMMARY OF TEST RESULTS FOR FCC PART 15C & IC RSS-210	9
4	FCC §15.205, §15.209 & §15.247(C), IC RSS-210 §A8.5 - SPURIOUS RADIATED EMISSIONS	10
4.1	APPLICABLE STANDARD	10
4.2	TEST SETUP	11
4.3	TEST EQUIPMENT LIST AND DETAILS	12
4.4	ENVIRONMENTAL CONDITIONS	12
4.5	TEST PROCEDURE	12
4.6	CORRECTED AMPLITUDE & MARGIN CALCULATION	12
4.7	SUMMARY OF TEST RESULTS	13
4.8	RADIATED SPURIOUS EMISSIONS TEST DATA	13
5	EXHIBIT A – FCC & IC EQUIPMENT LABELING REQUIREMENTS	15
5.1	FCC § 2.925 IDENTIFICATION OF EQUIPMENT	15
5.2	FCC ID LABELING REQUIREMENTS AS PER FCC § 15.19	15
5.3	IC ID LABELING REQUIREMENTS AS PER RSS-GEN § 5.2	15
5.4	SUGGESTED FCC ID & IC LABEL	16
6	EXHIBIT B TEST SETUP PHOTOS	17
6.1	RADIATED EMISSIONS – FRONT VIEW	17
6.2	RADIATED EMISSIONS – REAR VIEW	17
7	EXHIBIT C - EUT PHOTOGRAPHS	18
7.1	EUT- TOP SIDE VIEW	18
7.2	EUT- BOTTOM SIDE VIEW	18
7.3	EUT- FRONT SIDE VIEW	19
7.4	EUT- REAR SIDE VIEW	19
7.5	EUT- MAIN BOARD A-TOP SIDE VIEW	20
7.6	EUT- MAIN BOARD A -BOTTOM SIDE VIEW	20

7.7	EUT- DISPLAY BOARD ASSEMBLY VIEW	21
7.8	EUT- TERMINAL BOARD ASSEMBLY VIEW	21
7.9	EUT- 900MHZ RADIO BOARD WITH RF SHIELD-TOP SIDE VIEW	22
7.10	EUT- 900MHZ RADIO BOARD WITHOUT RF SHIELD-TOP SIDE VIEW	22
7.11	EUT- 900MHZ RADIO BOARD -BOTTOM SIDE VIEW	23
7.12	EUT- GPS RECEIVER ANTENNA.....	23
7.13	EUT- 5 DBI ANTENNA	24
7.14	EUT- AC/DC POWER SUPPLY-VIEW	24

1 GENERAL INFORMATION

1.1 Product Description for Equipment under Test (EUT)

The *Trimble Navigation Limited* Product, *FCC ID: JUP-5580090, IC: 1756A-5580090, model: Wamel* or the “EUT” as referred to this report is a triple-frequency GPS plus GLONASS receiver with the ability to receive OmniSTAR corrections. The SPS851 can operate as a base station or rover. The receiver can be configured using the keypad and display, web browser, or Trimble SCS900 Site Controller software. The SPS851 makes it easy to set up a mobile base station or a permanent base station for continuous operation. The SPS851 is also an ideal mobile receiver for semi-permanent mounting on vehicles and marine vessels. The SPS851 has an optional 900 MHz FHSS transceiver used to transmit or receive RTK (Real Time Kinematic) GPS data. The SPS851 also has an Infineon Bluetooth module PBA31308 for Bluetooth connectivity with other devices. The SPS751, SPS651 and SPS551 are less functional versions of the SPSx51 family, with fewer options than the SPS851. The AgGPS RTK Base 900, AgGPS 432 and AgGPS 442 are equivalent products aimed for the agricultural industry. All aforementioned models will be referred to in internal documentation as models: 58555-6X, 58555-90, and 58555-00.

1.2 Mechanical Description

The EUT is a 900 MHz FHSS Radio Transceiver of metallic construction that measures approximately 226 mm (L) x 121 mm (W) x 57 mm (H) and weighs 1652 grams.

** The test data gathered are from typical production sample, serial number: 4612K00874, provided by the manufacturer.*

1.3 EUT Photo

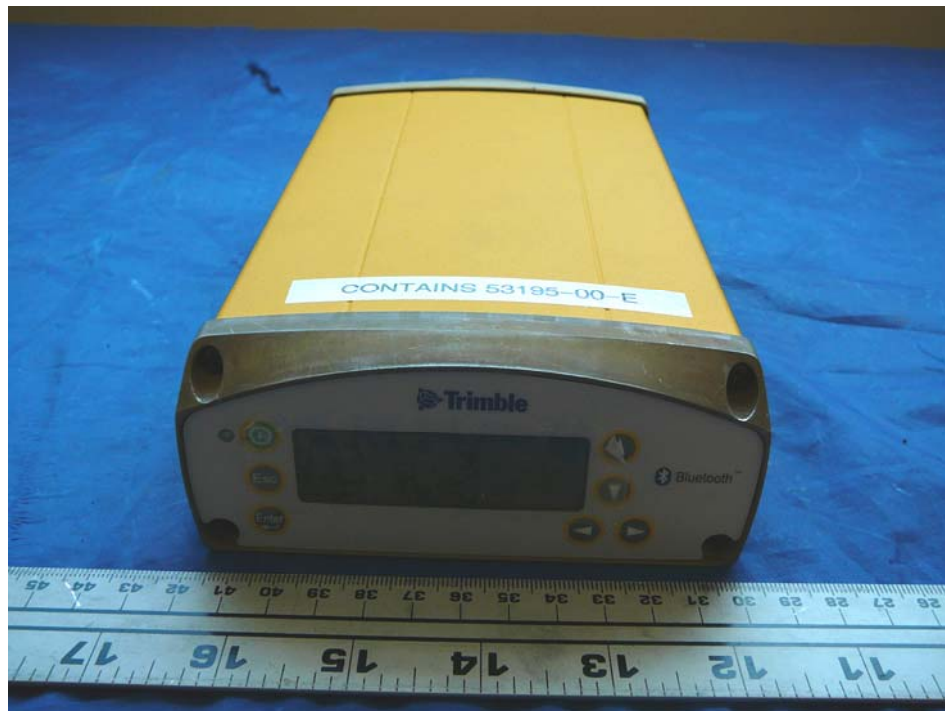

Please see additional photos in Exhibit C

1.4 Objective

This report is prepared on behalf of Trimble Navigation limited in accordance with Part 2, Subpart J, Part 15, Subparts A, B and C of the Federal Communication Commissions rules and Industry Canada RSS-210 Issue 7, June 2007 standard.

The objective is to determine compliance with FCC and IC standards, rules and limits for this device including:

- Radiated Spurious Emissions
- Restricted Band

1.5 Related Submittal(s)/ Grant(s)

The original non-RoHS 900MHz FHSS Radio was tested in Elliott Lab with FCC ID: JUP-5580090 and IC ID: 1756A-5580090. Additional testing was performed.

Please refer to original report number R61810 which was prepared by Elliott Lab for other FCC 15.247 radio tests which include Channel Bandwidth, Channel Output Power, Channel Separation and Number of Channels.

1.6 Test Methodology

All measurements contained in this report were conducted in accordance with ANSI C63.4-2003.

1.7 Measurement Uncertainty

All measurements involve certain levels of uncertainties, especially in field of EMC. The factors contributing to uncertainties are spectrum analyzer, cable loss, antenna factor calibration, antenna directivity, antenna factor variation with height, antenna phase center variation, antenna factor frequency interpolation, measurement distance variation, site imperfections, mismatch (average), and system repeatability.

Based on NIS 81, The Treatment of Uncertainty in EMC Measurements, the values range from ± 2.0 dB for Conducted Emissions tests and ± 4.0 dB for Radiated Emissions tests are the most accurate estimates pertaining to uncertainty of EMC measurements at BACL.

Detailed instrumentation measurement uncertainties can be found in BACL report QAP-018.

1.8 Test Facility

The test site used by BACL Corp. to collect radiated and conducted emissions measurement data is located at its facility in Sunnyvale, California, USA.

The test site at BACL Corp. has been fully described in reports submitted to the Federal Communication Commission (FCC) and Voluntary Control Council for Interference (VCCI). The details of these reports have been found to be in compliance with the requirements of Section 2.948 of the FCC Rules on February 11, 1997 and December 10, 1997 and Article 8 of the VCCI regulations on December 25, 1997. The facility also complies with the test methods and procedures set forth in ANSI C63.4-2003 & TIA/EIA-603.

The Federal Communications Commission and Voluntary Control Council for Interference have the reports on file and they are listed under FCC registration number: 90464 and VCCI Registration No.: R-2463 and C-2698. The test site has been approved by the FCC and VCCI for public use and is listed in the FCC Public Access Link (PAL) database.

Additionally, BACL Corp. is a National Institute of Standards and Technology (NIST) accredited laboratory under the National Voluntary Laboratory Accredited Program (Lab Code 200167-0). The current scope of accreditations can be found at <http://ts.nist.gov/ts/htdocs/210/214/scopes/2001670.htm>.

2 SYSTEM TEST CONFIGURATION

2.1 Justification

The EUT was configured for testing according to ANSI C63.4-2003.

The EUT was tested in the normal (native) operating mode to represent *worst*-case results during the final qualification test.

2.2 Special Accessories

As shown in following test block diagram, all interface cables used for compliance testing are shielded.

2.3 Equipment Modifications

N/A

2.4 Power Supply and Line Filters

Manufacturer	Description	Model	Serial Number
AULT	AC Adaptor (base)	PW174KA1802F02	NA

2.5 Internal Configuration

Manufacturer	Description	Part Number	Rev
Trimble Navigation	Main Board A	55212-20-C	7
Trimble Navigation	Display PCB Board	PW-130-10K	NA
Trimble Navigation	Main Board B	55212-C	NA

2.6 Local Support Equipment List and Details

Manufacturer	Description	Model	Serial Number
Dell	Laptop	Latitude D620	-
Trimble Navigation	5 dBi Antenna	-	NA
Trimble Navigation	GPS Receiver Antenna	ZEHYR model 2	-

2.7 Interface Ports and Cabling

Cable Description	Length (m)	From	To
Serial Cable	<3m	EUT	Laptop

2.8 Test Setup Block Diagram

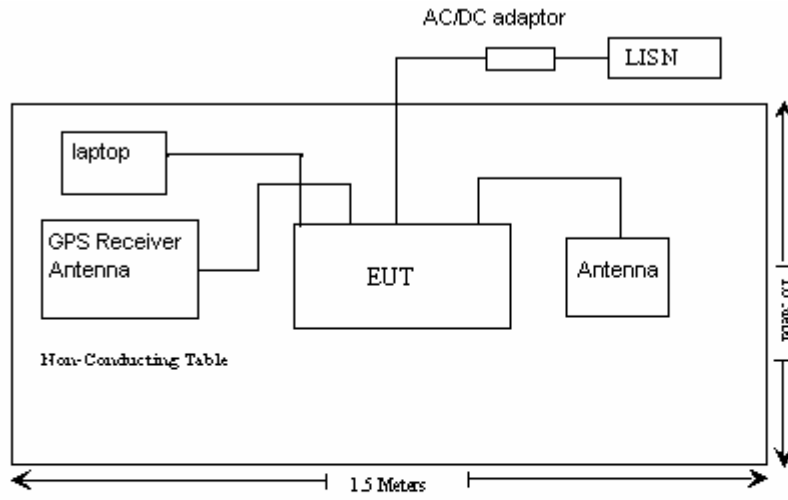

3 SUMMARY OF TEST RESULTS FOR FCC PART 15C & IC RSS-210

FCC 15C / RSS-210 Rules	Description of Test	Result
FCC §15.247 (i) and §2.1091, IC RSS-Gen 5.5 & RSS-102	RF Exposure	Please refer to Original Report*
FCC §15.203, IC RSS-Gen §7.1.4	Antenna Requirement	Please refer to Original Report*
FCC §15.207 (a), IC RSS-Gen §7.2.2	Conducted Emissions	Please refer to Original Report*
FCC §2.1051 & §15.247(d), RSS210 § A8.5 § RSS-Gen §7.2	Spurious Emissions at Antenna Port	Please refer to Original Report*
FCC §15.205, §15.209 & §15.247(c), IC RSS-210 §A8.5	Radiated Spurious Emissions	Compliant
FCC §15.205, RSS-210 §A8.5	Restricted Band	Compliant
§15.109, 15.209 (a) & §15.247(d), RSS-Gen §6(a)	Receiver Spurious Emissions	Please refer to Original Report*
§15.247 (a)(1), RSS-210 §A8.1 (a)	20 dB Bandwidth & 99% Bandwidth	Please refer to Original Report*
§15.247 (a)(1), RSS-210 §A8.1(2)	Hopping Channel Separation	Please refer to Original Report*
§15.247 (a)(1)(iii), RSS-210 §A8.1(4)	Number of Hopping Frequencies Channel Used	Please refer to Original Report*
§15.247 (a)(1)(iii), RSS-210 §A8.1(4)	Dwell Time	Please refer to Original Report*
§15.247 (b)(3), RSS210 § A8.4	Maximum Peak Output Power	Please refer to Original Report*
§ 15.247 (d), RSS210 § A8.5	100 kHz Bandwidth of Frequency Band Edge	Please refer to Original Report*

*Original submission FCC ID: JUP-5580090 filed 2006-03-13.

*Original submission IC: 1756A-5580090 filed 2007-03-29.

4 FCC §15.205, §15.209 & §15.247(c), IC RSS-210 §A8.5 - Spurious Radiated Emissions

4.1 Applicable Standard

As per FCC §15.35(d): Unless otherwise specified, on any frequency or frequencies above 1000 MHz, the radiated emission limits are based on the use of measurement instrumentation employing an average detector function. Unless otherwise specified, measurements above 1000 MHz shall be performed using a minimum resolution bandwidth of 1 MHz.

As per FCC §15.209(a): Except as provided elsewhere in this Subpart, the emissions from an intentional radiator shall not exceed the field strength levels specified in the following table

Frequency (MHz)	Field Strength (micro volts/meter)	Measurement Distance (meters)
0.009 - 0.490	2400/F(kHz)	300
0.490 - 1.705	24000/F(kHz)	30
1.705 - 30.0	30	30
30 - 88	100**	3
88 - 216	150**	3
216 - 960	200**	3
Above 960	500	3

** Except as provided in paragraph (g), fundamental emissions from intentional radiators operating under this Section shall not be located in the frequency bands 54-72 MHz, 76-88 MHz, 174-216 MHz or 470-806 MHz. However, operation within these frequency bands is permitted under other sections of this Part, e.g., Sections 15.231 and 15.241.

As per FCC §15.247(c)(1)(i): Systems operating in the 2400-2483.5 MHz band that are used exclusively for fixed, point-to-point operations may employ transmitting antennas with directional gain greater than 6 dBi provided the maximum conducted output power of the intentional radiator is reduced by 1 dB for every 3 dB that the directional gain of the antenna exceeds 6 dBi.

As Per FCC §15.205(a) except as show in paragraph (d) of this section, only spurious emissions are permitted in any of the frequency bands listed below:

F (MHz)	F (MHz)	F (MHz)	F (GHz)
0.090 – 0.110	16.42 – 16.423	960 – 1240	4.5 – 5.15
0.495 – 0.505	16.69475 – 16.69525	1300 – 1427	5.35 – 5.46
2.1735 – 2.1905	25.5 – 25.67	1435 – 1626.5	7.25 – 7.75
4.125 – 4.128	37.5 – 38.25	1645.5 – 1646.5	8.025 – 8.5
4.17725 – 4.17775	73 – 74.6	1660 – 1710	9.0 – 9.2
4.20725 – 4.20775	74.8 – 75.2	1718.8 – 1722.2	9.3 – 9.5
6.215 – 6.218	108 – 121.94	2200 – 2300	10.6 – 12.7
6.26775 – 6.26825	123 – 138	2310 – 2390	13.25 – 13.4
6.31175 – 6.31225	149.9 – 150.05	2483.5 – 2500	14.47 – 14.5
8.291 – 8.294	156.52475 – 156.52525	2690 – 2900	15.35 – 16.2
8.362 – 8.366	156.7 – 156.9	3260 – 3267	17.7 – 21.4
8.37625 – 8.38675	162.0125 – 167.17	3.332 – 3.339	22.01 – 23.12
8.41425 – 8.41475	167.72 – 173.2	3.3458 – 3.358	23.6 – 24.0
12.29 – 12.293	240 – 285	3600 – 4400	31.2 – 31.8
12.51975 – 12.52025	322 – 335.4		36.43 – 36.5
12.57675 – 12.57725	399.9 – 410		Above 38.6
13.36 – 13.41	608 – 614		

As per FCC §15.247 (d) In any 100 kHz bandwidth outside the frequency band in which the spread spectrum or digitally modulated intentional radiator is operating, the radio frequency power that is produced by the intentional radiator shall be at least 20 dB below that in the 100 kHz bandwidth within the band that contains the highest level of the desired power, based on either an RF conducted or a radiated measurement, provided the transmitter demonstrates compliance with the peak conducted power limits. If the transmitter complies with the conducted power limits based on the use of RMS averaging over a time interval, as permitted under paragraph (b)(3) of this section, the attenuation required under this paragraph shall be 30 dB instead of 20 dB. Attenuation below the general limits specified in §15.209(a) is not required. In addition, radiated emissions which fall in the restricted bands, as defined in §15.205(a), must also comply with the radiated emission limits specified in §15.209(a) (see §15.205(c)).

IC RSS-GEN §4.9 the measurement method shall be described in the test report. The same parameter, peak power or average power, used for the transmitter output power measurement shall be used for unwanted emission measurements. The search for unwanted emissions shall be from the lowest frequency internally generated or used in the device (local oscillator, intermediate or carrier frequency), or from 30 MHz, whichever is the lower, to the 5th harmonic of the highest frequency generated without exceeding 40 GHz.

4.2 Test Setup

The radiated emissions tests were performed in the shielded room, using the setup in accordance with ANSI C63.4-2003. The specification used was the FCC 15 Subpart C limits.

4.3 Test Equipment List and Details

Manufacturer	Description	Model	Serial Number	Calibration Date
HP	Pre amplifier	8447D	2944A07030	2007-11-12
Agilent	Pre amplifier	8449B	3008A01978	2007-11-02
Sunol Science	Combination Antenna	JB1 Antenna	A013105-3	2008-03-25
Antenna Research Associates, Inc.	Horn Antenna	DRG-118/A	1132	2007-06-18
Rohde & Schwarz	EMI Test Receiver	ESCI 1166.595 0K03	1000337	2008-04-21
Sunol Science	System Controller	SC99V	122303-1	NR
Agilent	Spectrum analyzer	E4440A	MY44303352	2008-04-28

* **Statement of Traceability: BACL Corp.** attests that all calibrations have been performed per the NVLAP requirements, traceable to the NIST.

4.4 Environmental Conditions

Temperature:	20° C
Relative Humidity:	400 %
ATM Pressure:	1012 mbar

*The testing was performed by Xiao Ming Hu on 2008-05-30.

4.5 Test Procedure

Maximizing procedure was performed on the six (6) highest emissions to ensure EUT compliance is with all installation combinations.

All data were recorded in the peak detection mode. Quasi-peak readings was performed only when an emissions was found to be marginal (within -4 dB of specification limits), and are distinguished with a "QP" in the data table.

4.6 Corrected Amplitude & Margin Calculation

The Corrected Amplitude is calculated by adding the Antenna Factor and Cable Factor, and subtracting the Amplifier Gain from the Amplitude reading. The basic equation is as follows:

$$\text{Corrected Amplitude} = \text{Indicated Reading} + \text{Antenna Factor} + \text{Cable Factor} - \text{Amplifier Gain}$$

The "**Margin**" column of the following data tables indicates the degree of compliance with the applicable limit. For example, a margin of -7dB means the emissions are 7dB below the maximum limit. The equation for margin calculation is as follows:

$$\text{Margin} = \text{Corrected Amplitude} - \text{Limit}$$

4.7 Summary of Test Results

According to the data hereinafter, the EUT complied with the FCC Title 47, Part 15 sections 15.205, 15.209 and Subpart C 15.247 standards' limits, and had the margin from the limits of:

Radiated spurious emissions above 1GHz

-12.47 dB at 8704.518 MHz in the **Vertical** polarization, 1 GHz –10 GHz, Low Channel

-14.6 dB at 8728.332 MHz in the **Vertical** polarization, 1 GHz – 10 GHz, Middle Channel

-14.87 dB at 9795.072 MHz in the **Horizontal** polarization, 1 GHz – 10 GHz, High Channel

4.8 Radiated Spurious Emissions Test Data

Low Channel @ 902.621MHz

Frequency (MHz)	Raw data (dBuV/m)	Cable Loss (dB)	Antenna Factor & Pre Amp Gain (dB)	Corrected Reading (dBuV/m)	Measurement Type (PK/AV)	Ant. Polarity (V/H)	Ant. Height (cm)	Azt (Deg)	Limit (dBuV/m)	Margin (dB)
8704.518	28.00	11.17	2.36	41.53	AV	V	198	49	54	-12.47
1804.894	61.13	4.94	-9.4	56.67	PK	V	200	0	74	-17.33
8703.057	41.68	11.17	2.36	55.21	PK	V	100	0	74	-18.79
1805.226	27.23	4.83	-10.43	21.63	AV	V	169	263	54	-32.37

Middle Channel @ 914.8496MHz

Frequency (MHz)	Raw data (dBuV/m)	Cable Loss (dB)	Antenna Factor & Pre Amp Gain (dB)	Corrected Reading (dBuV/m)	Measurement Type (PK/AV)	Ant. Polarity (V/H)	Ant. Height (cm)	Azt (Deg)	Limit (dBuV/m)	Margin (dB)
8728.438	25.85	11.19	2.35	39.4	AV	V	171	45	54	-14.6
8728.322	41.38	11.19	2.35	54.92	PK	V	200	0	74	-19.08
1892.701	50.56	4.94	-9.37	46.14	PK	V	100	0	74	-27.86
1894.277	29.86	4.95	-9.35	25.46	AV	V	98	209	54	-28.54
1995.367	26.7	5.07	-8.21	23.56	AV	V	186	244	54	-30.44
1996.569	46.12	5.08	-8.2	42.99	PK	V	100	0	74	-31.01
1447.6	28.34	4.32	-12.4	20.26	AV	V	160	14	54	-33.74
1449.158	47.4	4.32	-12.4	39.33	PK	V	100	0	74	-34.67

High Channel @ 927.5877MHz

Frequency (MHz)	Raw data (dBuV/m)	Cable Loss (dB)	Antenna Factor & Pre Amp Gain (dB)	Corrected Reading (dBuV/m)	Measurement Type (PK/AV)	Ant. Polarity (V/H)	Ant. Height (cm)	Azt (Deg)	Limit (dBuV/m)	Margin (dB)
9794.851	24.9	11.9	2.33	39.13	AV	H	148	103	54	-14.87
9795.072	41.32	11.9	2.33	55.54	PK	H	100	0	74	-18.46
1665.315	54.2	4.63	-11.52	47.31	PK	H	100	0	74	-26.69
1666.731	31.81	4.63	-11.51	24.93	AV	H	140	247	54	-29.07