



Canada

RF Test Report

As per

RSS-137 Issue 2:2009 & FCC Part 90 Subpart M:2015

Location and Monitoring Service (LMS)
Operation in the 902 -928 MHz Band
on the

JANUS™ Front Mount Exterior OBU
Model: 801800C-TAB

Issued by:

TÜV SÜD Canada Inc.
11 Gordon Collins Dr,
Gormley, ON, L0H 1G0
Canada
Ph: (905) 883-7255

Testing produced for
kapsch >>>
See Appendix A for full client &
EUT details.

Prepared by

Jadon Bull,
Project Engineer

Reviewed by

Scott Drysdale,
EMC Regional Manager



Testing Laboratory
Certificate #2955.02



Registration #
CA6844



Client	Kapsch TrafficCom Canada Inc.	
Product	JANUS™ Front Mount Exterior OBU Model: 801800C-TAB	
Standard(s)	RSS 137 Issue 2:2009 FCC Part 90 Subpart M:2015	

Table of Contents

Table of Contents	2
Report Scope	3
Summary	4
Test Results Summary	5
Notes, Justifications, or Deviations	6
Sample Calculation(s).....	6
Applicable Standards, Specifications and Methods.....	7
Document Revision Status	8
Definitions and Acronyms	9
Testing Facility	10
Calibrations and Accreditations	10
Testing Environmental Conditions and Dates	11
Detailed Test Results Section	12
Output Power and Antenna Heights	13
Occupied Bandwidth.....	15
Emission Mask.....	19
Temperature Frequency Stability.....	29
Appendix A – EUT Summary.....	31
Appendix B – EUT and Test Setup Photos.....	33

Client	Kapsch TrafficCom Canada Inc.	
Product	JANUS™ Front Mount Exterior OBU Model: 801800C-TAB	
Standard(s)	RSS 137 Issue 2:2009 FCC Part 90 Subpart M:2015	

Report Scope

This report addresses the EMC verification testing and test results of the **JANUS™ Front Mount Exterior OBU, Model: 801800C-TAB**, and is herein referred to as EUT (Equipment Under Test). The EUT was tested for compliance against the following standards:

RSS-137 Issue 2:2009

FCC Part 90 Subpart M:2015

Test procedures, results, justifications, and engineering considerations, if any, follow later in this report.

The results contained in this report relate only to the item(s) tested.

This report does not imply product endorsement by any government, accreditation agency, or TÜV SÜD Canada Inc.

Opinions or interpretations expressed in this report, if any, are outside the scope of TÜV SÜD Canada Inc. accreditations. Any opinions expressed do not necessarily reflect the opinions of TÜV SÜD Canada Inc., unless otherwise stated.

Client	Kapsch TrafficCom Canada Inc.	
Product	JANUS™ Front Mount Exterior OBU Model: 801800C-TAB	
Standard(s)	RSS 137 Issue 2:2009 FCC Part 90 Subpart M:2015	

Summary

The results contained in this report relate only to the item(s) tested.

EUT:	JANUS™ Front Mount Exterior OBU Model: 801800C-TAB
FCC Certification #, FCC ID:	JQU801800C
Industry Canada Certification #, IC:	2665A-801800C
EUT passed all tests performed	Yes
Tests conducted by	Jadon Bull
Report Reviewed by	Scott Drysdale

For testing dates, see "Testing Environmental Conditions and Dates".

Client	Kapsch TrafficCom Canada Inc.	
Product	JANUS™ Front Mount Exterior OBU Model: 801800C-TAB	
Standard(s)	RSS 137 Issue 2:2009 FCC Part 90 Subpart M:2015	

Test Results Summary

Standard/Method	Description	Class/Limit	Result
FCC 90.205 RSS-137 Clause 6.4	Output Power	30 W	Pass
FCC 90.207 RSS-137 Clause 6.2	Types of Modulation	--	Pass See Justification
FCC 90.209 RSS-137 Clause 6.1.2	Occupied Bandwidth	902 - 904 MHz: 2 MHz 909.75 – 921.75 MHz 12 MHz	Pass
FCC 90.210 (K) RSS-137 Clause 6.5.3	Spurious antenna port conducted emissions	55 + 10 log ₁₀ P _{max} dB.	Pass
FCC 90.210 RSS-137 Clause 6.5.3	Spurious radiated emissions	55 + 10 log ₁₀ P _{max} dB.	Pass
FCC 90.213 RSS-137 Clause 6.3	Frequency stability	2.5 ppm	N/A See Justification
FCC 90.214	Transient Behavior	--	N/A See Justification
Overall Result			Pass

If the product as tested or otherwise complies with the specification, the EUT is deemed to comply with the requirement and is deemed a 'PASS' grade. If not 'FAIL' grade will be issued. Note that 'PASS' / 'FAIL' grade is independent of any measurement uncertainties. A 'PASS' / 'FAIL' grade within measurement uncertainty is marked with a '*'.

Client	Kapsch TrafficCom Canada Inc.	
Product	JANUS™ Front Mount Exterior OBU Model: 801800C-TAB	
Standard(s)	RSS 137 Issue 2:2009 FCC Part 90 Subpart M:2015	

Notes, Justifications, or Deviations

The following notes, justifications for tests not performed or deviations from the above listed specifications apply:

For the Types of Emissions Requirement (FCC 90.207), the EUT uses Shaped ON-OFF Keying to transmit information. According to FCC 2.201, the EUT is classified as K1D type of emission and is therefore allowable under FCC 90.207.

For the Frequency Stability Requirement (FCC 90.213), the EUT is a mobile transponder and therefore is not subject to frequency tolerance restrictions as per FCC 90.213(a)(13). However, this test was performed, and results are included in this test report for information purposes only as requested by the client.

For the Transient Behavior Requirement (FCC 90.214), the EUT operates in the 902-928 MHz band, and therefore this requirement is not applicable.

For the requirements of FCC 90.210 (K) and FCC 2.1053 Measurements required: Field strength of spurious radiation. Spurious radiated emissions of the EUT was performed at 3 meters. The limit specified in FCC 90.210 (K) is: On any frequency outside the licensee's sub-band edges, the peak power of any emission shall be attenuated by $55 + 10 \log(P)$ where P is the highest emission (Watts) of the transmitter. For all intents and purposes, the limit is -25 dBm ERP. The 3 meter field strength limit for the EUT is given below:

$$E(\text{dB}\mu\text{V/m}) = \text{ERIP}(\text{dBm}) + 95.2$$

$$\text{Where EIRP} = \text{ERP} + 2.15$$

$$E(\text{dB}\mu\text{V/m}) = \text{ERP}(\text{dBm}) + 97.35$$

$$E(\text{dB}\mu\text{V/m}) = -25 \text{ dBm} + 97.35 = 72.35 \text{ dB}\mu\text{V}$$

This limit is applicable to all emission at 3 meter measurement distance.

Sample Calculation(s)

Radiated Emission Test

Margin = Limit – (Received Signal + Antenna Factor + Cable Loss – Pre-Amp Gain)

Margin = $50.5 \text{ dB}\mu\text{V/m} - (50 \text{ dB}\mu\text{V} + 10 \text{ dB} + 2.5 \text{ dB} - 20 \text{ dB})$

Margin = 8.0 dB (pass)

Client	Kapsch TrafficCom Canada Inc.	
Product	JANUS™ Front Mount Exterior OBU Model: 801800C-TAB	
Standard(s)	RSS 137 Issue 2:2009 FCC Part 90 Subpart M:2015	

Applicable Standards, Specifications and Methods

ANSI C63.4:2014	Methods of Measurement of Radio-Noise Emissions from Low-Voltage Electrical and Electronic Equipment in the Range of 9 kHz to 40 GHz
ANSI C63.26:2015	American National Standard for Compliance Testing of Transmitters Used in Licensed Radio Services
ANSI/TIA-603-E	Land Mobile FM or PM Communications Equipment Measurement and Performance Standards
CFR 47 FCC Part 2 Subpart J	Code of Federal Regulations – Equipment Authorization Procedure
CFR 47 FCC Part 90	Code of Federal Regulations – Private Land Mobile Radio Services
FCC KDB 412172	D01 Determining ERP and EIRP v01
RSS 137 Issue 2:2009	Spectrum Management and Telecommunications. Radio Standards Specification, Location and Monitoring Service in the Band 902-928 MHz.
RSS-GEN Issue 5 2018	General Requirements and Information for the Certification of Radio Apparatus
ISO/IEC 17025:2017	General Requirements for the Competence of Testing and Calibration Laboratories

Client	Kapsch TrafficCom Canada Inc.	
Product	JANUS™ Front Mount Exterior OBU Model: 801800C-TAB	
Standard(s)	RSS 137 Issue 2:2009 FCC Part 90 Subpart M:2015	

Document Revision Status

Revision	Date	Description
000	August 25, 2023	Initial Release

Client	Kapsch TrafficCom Canada Inc.	
Product	JANUS™ Front Mount Exterior OBU Model: 801800C-TAB	
Standard(s)	RSS 137 Issue 2:2009 FCC Part 90 Subpart M:2015	

Definitions and Acronyms

The following definitions and acronyms are applicable in this report.
See also ANSI C63.14.

AE – Auxiliary Equipment. A digital accessory that feeds data into or receives data from another device (host) that in turn, controls its operation.

BW – Bandwidth. Unless otherwise stated, this refers to the 6 dB bandwidth.

EMC – Electro-Magnetic Compatibility. The ability of an equipment or system to function satisfactorily in its electromagnetic environment without introducing intolerable electromagnetic disturbances to anything in that environment.

EMI – Electro-Magnetic Immunity. The ability to maintain a specified performance when the equipment is subjected to disturbance (unwanted) signals of specified levels.

EUT – Equipment Under Test. A device or system being evaluated for compliance that is representative of a product to be marketed.

ITE – Information Technology Equipment with a primary function(s) of entry, storage, display, retrieval, transmission, processing, switching, or control, of data.

LISN – Line Impedance Stabilization Network

NCR – No Calibration Required

RF – Radio Frequency

Client	Kapsch TrafficCom Canada Inc.	
Product	JANUS™ Front Mount Exterior OBU Model: 801800C-TAB	
Standard(s)	RSS 137 Issue 2:2009 FCC Part 90 Subpart M:2015	

Testing Facility

Testing for EMC on the EUT was carried out at TÜV SÜD Canada testing lab near Toronto, Ontario. The testing lab has calibrated 3m semi-anechoic chambers which allow measurements on a EUT that has a maximum width or length of up to 2m and a height of up to 3m. The testing lab also has a calibrated 10m Open Area Test Site (OATS). The chambers are equipped with a turntable that is capable of testing devices up to 5000lb in weight and are equipped with a mast that controls the polarization and height of the antenna. Control of the mast occurs in the control room adjoining the shielded chamber. This facility is capable of testing products that are rated for single phase or 3-phase AC input and DC capability is also available. Radiated emission measurements are performed using a BiLog antenna and a Horn antenna where applicable. Conducted emissions, unless otherwise stated, are performed using a LISN and using the vertical ground plane if applicable.

Calibrations and Accreditations

The 3m semi-anechoic chamber is registered with Federal Communications Commission (FCC, CA6844), Innovation, Science and Economic Development Canada (ISED, 6844A-3) and Voluntary Control Council for Interference (VCCI, R-14023, G-20072, C-14498, and T-20060). This chamber was calibrated for Normalized Site Attenuation (NSA) using test procedures outlined in ANSI C63.4 "Methods of Measurement of Radio-Noise Emissions from Low-Voltage Electrical and Electronic Equipment in the Range of 9 kHz to 40 GHz". The chamber is lined with ferrite tiles and absorption cones to minimize any undesired reflections. The NSA data is kept on file at TÜV SÜD Canada. For radiated susceptibility testing, a 16 point field calibration has been performed on the chamber. The field uniformity data is kept on file at TÜV SÜD Canada. TÜV SÜD Canada Inc. is accredited to ISO 17025 by A2LA with Testing Certificate #2955.02. The laboratory's current scope of accreditation listing can be found as listed on the A2LA website. All measuring equipment is calibrated on an annual or biennial basis as listed for each respective test.

Client	Kapsch TrafficCom Canada Inc.	
Product	JANUS™ Front Mount Exterior OBU Model: 801800C-TAB	
Standard(s)	RSS 137 Issue 2:2009 FCC Part 90 Subpart M:2015	

Testing Environmental Conditions and Dates

Following environmental conditions were recorded in the facility during time of testing

Date	Test	Initials	Temperature (°C)	Humidity (%)	Pressure (kPa)
7/26/2023	Radiated Emissions	JB	24.8	52.9	101.5
7/26/2023	Antenna Conducted Emissions	JB	24.8	52.9	101.5
7/28/2023	Frequency Stability	JB	25.3	58.4	101.5

Client	Kapsch TrafficCom Canada Inc.	
Product	JANUS™ Front Mount Exterior OBU Model: 801800C-TAB	
Standard(s)	RSS 137 Issue 2:2009 FCC Part 90 Subpart M:2015	

Detailed Test Results Section

Client	Kapsch TrafficCom Canada Inc.	
Product	JANUS™ Front Mount Exterior OBU Model: 801800C-TAB	
Standard(s)	RSS 137 Issue 2:2009 FCC Part 90 Subpart M:2015	

Output Power and Antenna Heights

Purpose

The purpose of this test is to ensure that the maximum power conducted to the radiating element does not exceed the limits specified.

Limits

The limits are defined in FCC Part 90.205 (l) and RSS 137 Clause 6.4 as per the following paragraph:

902-928 MHz. LMS systems operating pursuant to subpart M of this part in the 902-927.25 MHz band will be authorized a maximum of 30 watts ERP. LMS equipment operating in the 927.25-928 MHz band will be authorized a maximum of 300 watts ERP. ERP must be measured as peak envelope power. Antenna heights will be as specified in §90.353(h).

Results

The EUT passed.

The EUT supports one protocol and operates only on a single channel. The EUT has a PCB antenna. Thus, antenna height is not applicable.

Radiated measurements were performed because the antenna is a PCB trace; the antenna gain is not accurately known and due to the impedance mismatch between the spectrum analyzer and the modified unit with antenna connector. KDB 412172 is used to determine the ERP of the EUT from a measured field.

$$P = \frac{(E*d)^2}{30}$$

Where:

- P is the EIRP in Watts
- E is the Electric Field in V/m
- d is distance in meters

$P(\text{dBm}) = E (\text{dBuV/m}) - 95.23$ for a measurement distance of 3 m.

and

$ERP = EIRP - 2.15$

Client	Kapsch TrafficCom Canada Inc.	
Product	JANUS™ Front Mount Exterior OBU Model: 801800C-TAB	
Standard(s)	RSS 137 Issue 2:2009 FCC Part 90 Subpart M:2015	

Graph(s)

The graph shown below are maximized peak measurement graphs measured with a resolution bandwidth greater OBW of the EUT over a full 0-360° and the polarity of the measuring antenna in the same polarity as the EUT's antenna.

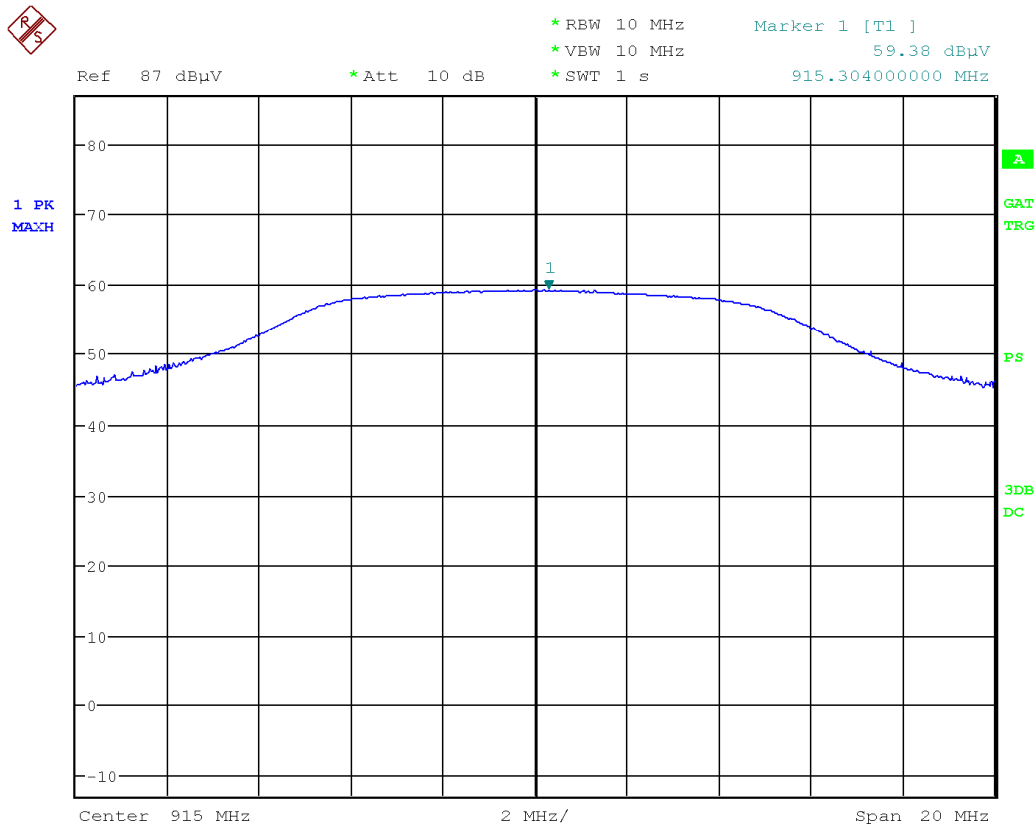

Date: 26.JUL.2023 12:15:55

Peak E-Field

Client	Kapsch TrafficCom Canada Inc.	
Product	JANUS™ Front Mount Exterior OBU Model: 801800C-TAB	
Standard(s)	RSS 137 Issue 2:2009 FCC Part 90 Subpart M:2015	

Frequency	Raw Reading (dBuV)	Antenna Factor (dB)	Attenuator Factor (dB)	Cable Factor (dB)	E-Field (dBuV/m)	ERP (dBm)	ERP (mW)
915	59.38	29.5	10.0	1.84	100.72	3.34	2.16

Note: See ‘Appendix B – EUT & Test Setup Photographs’ for photos showing the test set-up.

Test Equipment List

Equipment	Model No.	Manufacturer	Last Calibration / Verification Date	Next Calibration / Verification Date	Asset #
Spectrum Analyzer	ESU 40	Rohde & Schwarz	Feb. 11, 2022	Feb. 11, 2024	GEMC 233
BiLog Antenna	3142-C	ETS-Lindgren	Dec. 7, 2022	Dec. 7, 2024	GEMC 8
Attenuator 6 dB	612-6-1	Meca Electronics, Inc	NCR	NCR	GEMC 287
Attenuator 10 dB	6N10W-10	Inmet	NCR	NCR	GEMC 349
RF Cable <1GHz	LMR-400	LexTec	NCR	NCR	GEMC 274
RF Cable <1GHz	Sucoflex 104A	Huber+Suhner	NCR	NCR	GEMC 271
Emissions Software	V2.1.2	TUV SUD Canada, Inc.	NCR	NCR	GEMC 361

Occupied Bandwidth

Purpose

The purpose of this test is to ensure that the bandwidth occupied exceeds a stated minimum. This helps ensure the utilization of the frequency allocation is sufficiently wide. This also helps prevent corruption of data by ensuring adequate data separation to distinguish the reception of the intended information.

Limits

The Limit is as specified in FCC Part 90.209 and RSS-137 Clause 6.1.2.

The maximum authorized bandwidth shall be 12 MHz for non-multilateration LMS operations in the band 909.75-921.75 MHz and 2 MHz in the band 902.00-904.00 MHz.

Client	Kapsch TrafficCom Canada Inc.	
Product	JANUS™ Front Mount Exterior OBU Model: 801800C-TAB	
Standard(s)	RSS 137 Issue 2:2009 FCC Part 90 Subpart M:2015	

The maximum authorized bandwidth for multilateration LMS operations shall be 5.75 MHz in the 904.00-909.75 MHz band; 2 MHz in the 919.5-921.75 MHz band; 5.75 MHz in the 921.75-927.25 MHz band and its associated 927.25-927.50 MHz narrowband forward link; and 8.00 MHz if the 919.75-921.75 MHz and 921.75-927.25 MHz bands and their associated 927.25-927.50 MHz and 927.50-927.75 MHz narrowband forward links are aggregated.

Results

The EUT passed.

Frequency (MHz)	99% Bandwidth (MHz)	20 dB BW (MHz)
915.0	8.44	5.12

Client	Kapsch TrafficCom Canada Inc.	
Product	JANUS™ Front Mount Exterior OBU Model: 801800C-TAB	
Standard(s)	RSS 137 Issue 2:2009 FCC Part 90 Subpart M:2015	

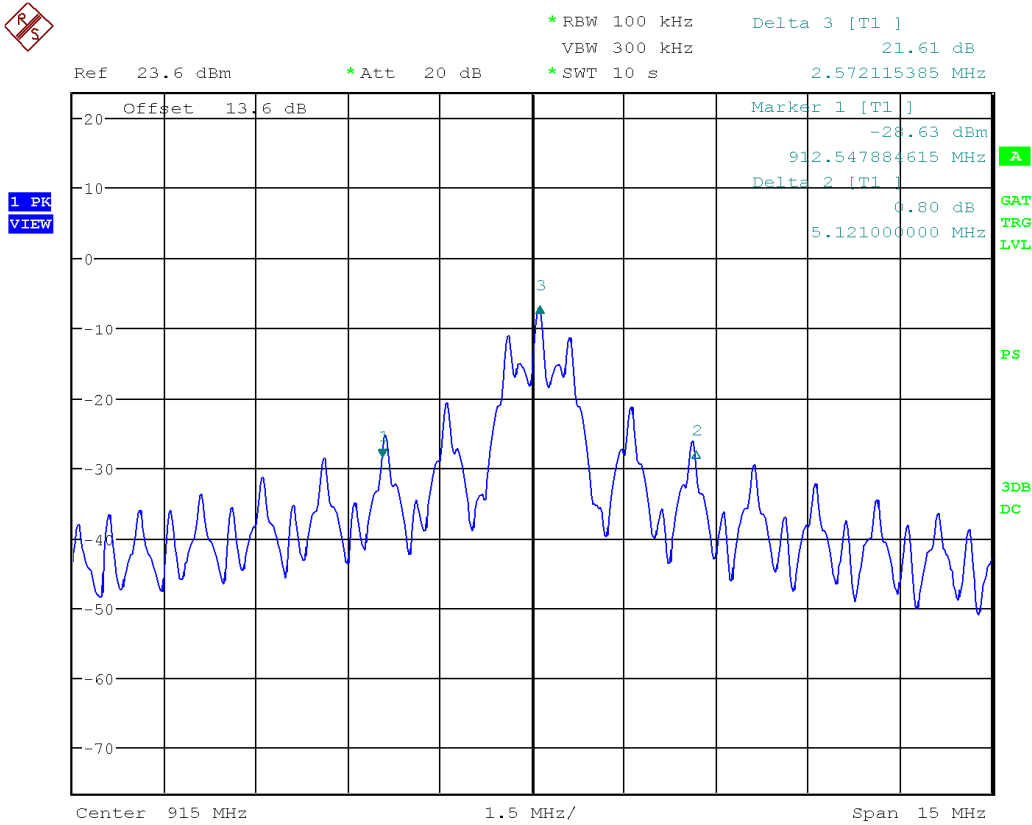

Date: 26.JUL.2023 15:45:42

20 dB Bandwidth

Note: See 'Appendix B – EUT & Test Setup Photographs' for photos showing the test set-up.

Test Equipment List

Equipment	Model No.	Manufacturer	Last Calibration Date	Next Calibration Date	Asset #
Spectrum Analyzer	ESU 40	Rohde & Schwarz	Feb. 11, 2022	Feb. 11, 2024	GEMC 233
Attenuator 10 dB	8493B	Agilent	NCR	NCR	GEMC 133

Client	Kapsch TrafficCom Canada Inc.	
Product	JANUS™ Front Mount Exterior OBU Model: 801800C-TAB	
Standard(s)	RSS 137 Issue 2:2009 FCC Part 90 Subpart M:2015	

Emission Mask

Purpose

The purpose of this test is to ensure that the maximum power conducted to the radiating element at frequencies outside of the authorized spectrum does not exceed the limits specified. This ensures that the only the intended signal is delivered to the radiating element.

Limits

The Limit is as specified in FCC Part 90.210 (K) and RSS-137 Clause 6.5.3

Emission Mask K—(1) Wideband multilateration transmitters. For transmitters authorized under subpart M to provide forward or reverse links in a multilateration system in the subbands 904-909.75 MHz, 921.75-927.25 MHz and 919.75-921.75 MHz, and which transmit an emission occupying more than 50 kHz bandwidth: in any 100 kHz band, the center frequency of which is removed from the center of authorized sub-band(s) by more than 50 percent of the authorized bandwidth, the power of emissions shall be attenuated below the transmitter output power, as specified by the following equation, but in no case less than 31 dB:

$$A=16+0.4 (D-50)+10 \log B \text{ (attenuation greater than 66 dB is not required)}$$

Where:

- A = attenuation (in decibels) below the maximum permitted output power level
- D = displacement of the center frequency of the measurement bandwidth from the center frequency of the authorized sub-band, expressed as a percentage of the authorized bandwidth B
- B = authorized bandwidth in megahertz.

(2) Narrowband forward link transmitters. For LMS multilateration narrowband forward link transmitters operating in the 927.25-928 MHz frequency band the power of any emission shall be attenuated below the transmitter output power (P) in accordance with following schedule:

On any frequency outside the authorized sub-band and removed from the edge of the authorized sub-band by a displacement frequency (f_a in kHz): at least $116 \log ((f_a+10)/6.1)$ dB or $50 + 10 \log (P)$ dB or 70 dB, whichever is the lesser attenuation.

(3) Other transmitters. For all other transmitters authorized under subpart M that operate in the 902-928 MHz band, the peak power of any emission shall be attenuated below the power of the highest emission contained within the licensee's sub-band in accordance with the following schedule:

Client	Kapsch TrafficCom Canada Inc.	
Product	JANUS™ Front Mount Exterior OBU Model: 801800C-TAB	
Standard(s)	RSS 137 Issue 2:2009 FCC Part 90 Subpart M:2015	

- (i) On any frequency within the authorized bandwidth: Zero dB.
- (ii) On any frequency outside the licensee's sub-band edges: $55 + 10 \log(P)$ dB, where (P) is the highest emission (watts) of the transmitter inside the licensee's sub-band.

(4) In the 902-928 MHz band, the resolution bandwidth of the instrumentation used to measure the emission power shall be 100 kHz, except that, in regard to paragraph (2) of this section, a minimum spectrum analyzer resolution bandwidth of 300 Hz shall be used for measurement center frequencies with 1 MHz of the edge of the authorized subband. The video filter bandwidth shall not be less than the resolution bandwidth.

(5) Emission power shall be measured in peak values.

(6) The LMS sub-band edges for non-multilateration systems for which emissions must be attenuated are 902.00, 904.00, 909.5 and 921.75 MHz.

Note: The EUT is a non- multilateration LMS transmitter. Emission limit (3) applies to the EUT. A $55 + 10 \log(P)$ dB attenuation (or -25 dBm absolute emission level) was applied all frequency from the outside authorized band.

Test procedure is as per eCFR 47 Part 2 Clause 2.1051.

Client	Kapsch TrafficCom Canada Inc.	
Product	JANUS™ Front Mount Exterior OBU Model: 801800C-TAB	
Standard(s)	RSS 137 Issue 2:2009 FCC Part 90 Subpart M:2015	

Conducted Measurements

Results

The EUT passed; it meets the Emissions Mask attenuation requirement at the band edges, measured from the antenna port.

The worst case is presented as a graph for the spectrum. Band edge requirements were shown for the lower band edge at 909.5 MHz in the low band where applicable. Band edge requirements were also shown for the higher band edge at 921.75 MHz in the high band where applicable.

Note: All measurements were made with an attenuator as appropriate to the measurement. The insertion loss was adjusted with Reference Level Offset function in the spectrum analyzer.

Client	Kapsch TrafficCom Canada Inc.	
Product	JANUS™ Front Mount Exterior OBU Model: 801800C-TAB	
Standard(s)	RSS 137 Issue 2:2009 FCC Part 90 Subpart M:2015	

Graph(s)

The graphs shown below shows the peak power output of the device during the antenna conducted measurement during transmit operation of the EUT.

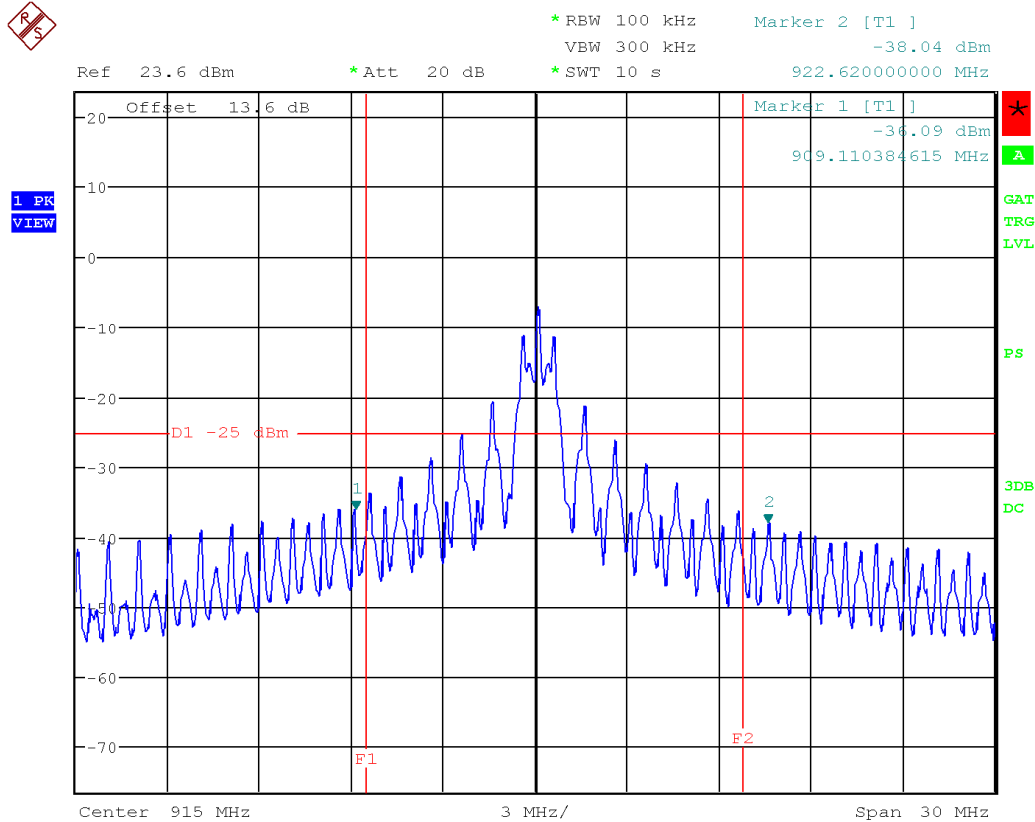

Date: 26.JUL.2023 15:49:56

Emissions Mask – Band Edges

Test Equipment List

Equipment	Model No.	Manufacturer	Last Calibration Date	Next Calibration Date	Asset #
Spectrum Analyzer	ESU 40	Rohde & Schwarz	Feb. 11, 2022	Feb. 11, 2024	GEMC 233

Client	Kapsch TrafficCom Canada Inc.	
Product	JANUS™ Front Mount Exterior OBU Model: 801800C-TAB	
Standard(s)	RSS 137 Issue 2:2009 FCC Part 90 Subpart M:2015	

Attenuator 10 dB	8493B	Agilent	NCR	NCR	GEMC 133
---------------------	-------	---------	-----	-----	----------

Radiated Measurements

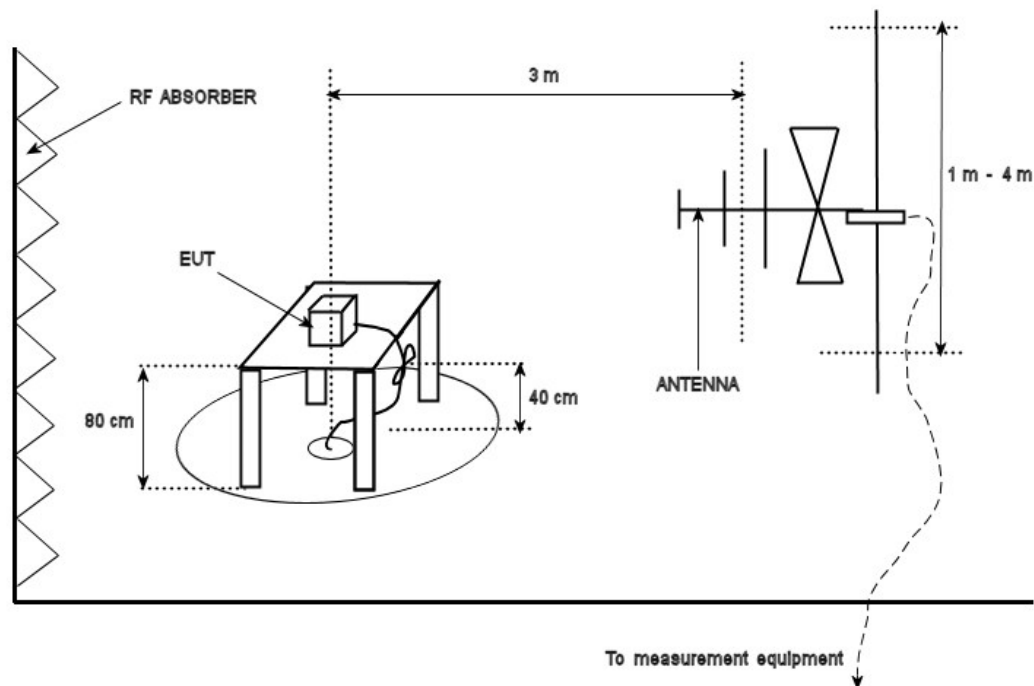

Typical Radiated Emissions Setup

Measurement Uncertainty

The expanded measurement uncertainty is calculated in accordance with CISPR 16-4-2 and is +/-4.4 dB with a 'k=2' coverage factor and a 95% confidence level.

Preliminary Graphs

Note the graphs shown below are for graphical illustration only. For final measurements with the appropriate detector, please refer to the final measurement table where applicable. The graph shown below is a maximized peak measurement graph, measured with a resolution bandwidth greater than the final required detector and over a full 0-360 rotation. This peaking process is done as a worst case measurement. This process enables the detection of frequencies of concern for final measurement, and provides considerable time savings.

The device was scanned to the 10th harmonic (a minimum of a 10 GHz).

Page 23 of 33	Report Issued: 8/25/2023	Report File #: 7169013405RF-000
---------------	--------------------------	---------------------------------

Client	Kapsch TrafficCom Canada Inc.	
Product	JANUS™ Front Mount Exterior OBU Model: 801800C-TAB	
Standard(s)	RSS 137 Issue 2:2009 FCC Part 90 Subpart M:2015	

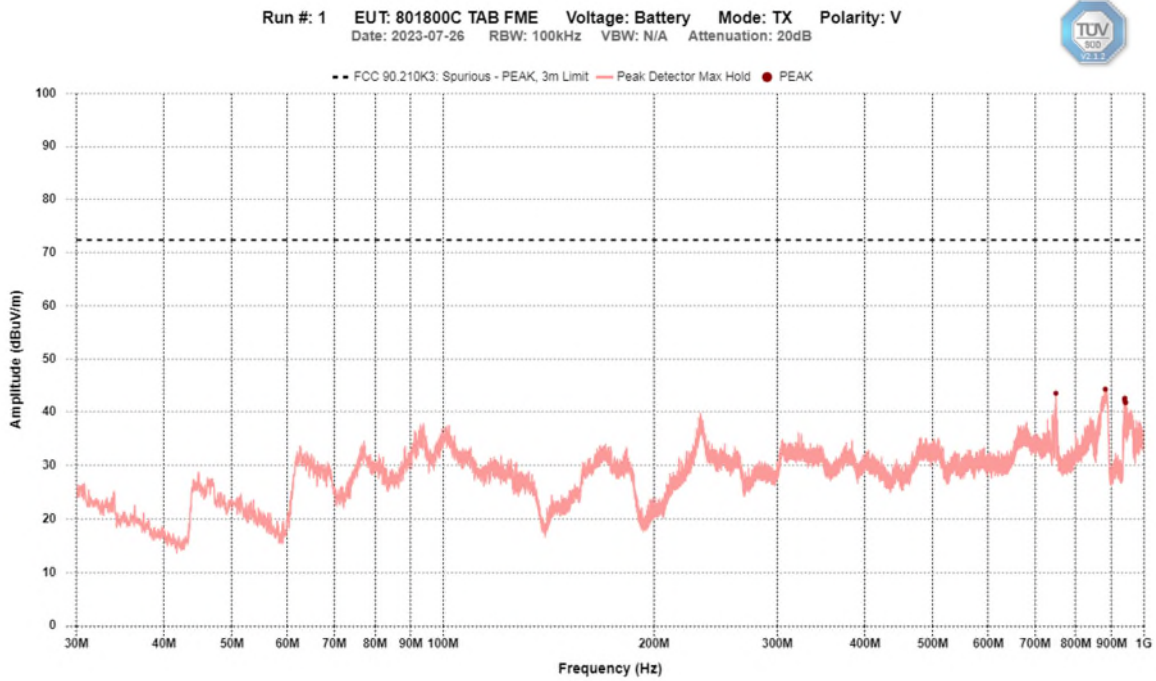

Vertical – Peak Emission Graph
30 MHz – 1 GHz

Client	Kapsch TrafficCom Canada Inc.	
Product	JANUS™ Front Mount Exterior OBU Model: 801800C-TAB	
Standard(s)	RSS 137 Issue 2:2009 FCC Part 90 Subpart M:2015	

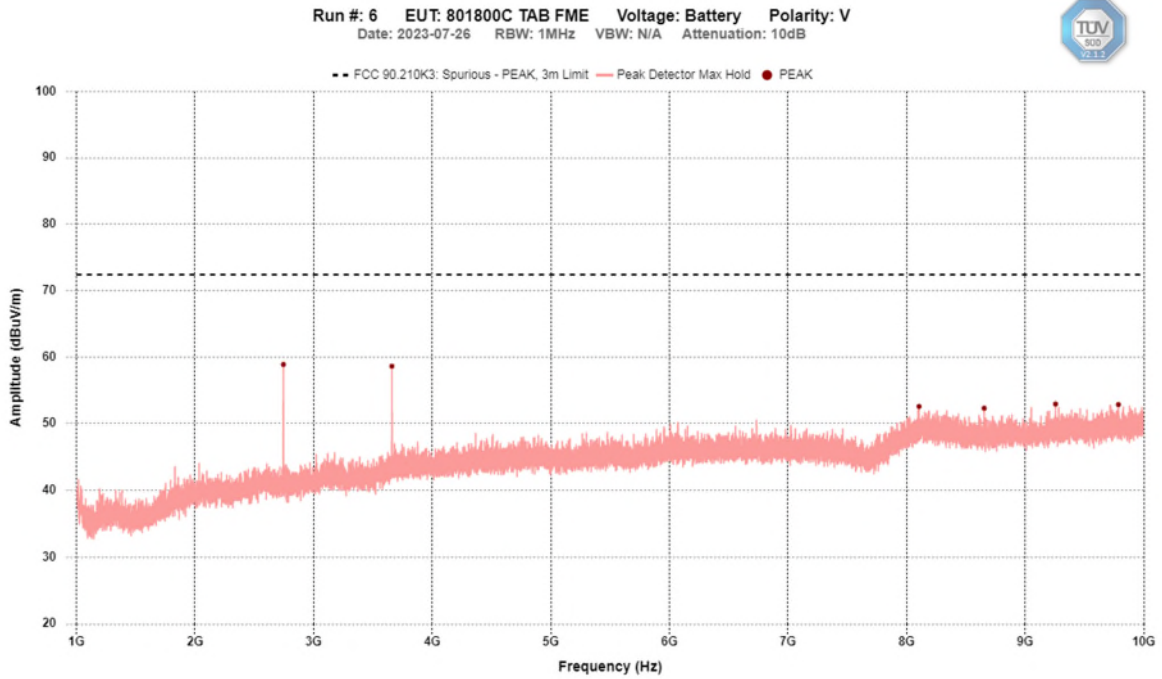

Vertical – Peak Emission Graph
1 GHz – 10 GHz

Client	Kapsch TrafficCom Canada Inc.	
Product	JANUS™ Front Mount Exterior OBU Model: 801800C-TAB	
Standard(s)	RSS 137 Issue 2:2009 FCC Part 90 Subpart M:2015	

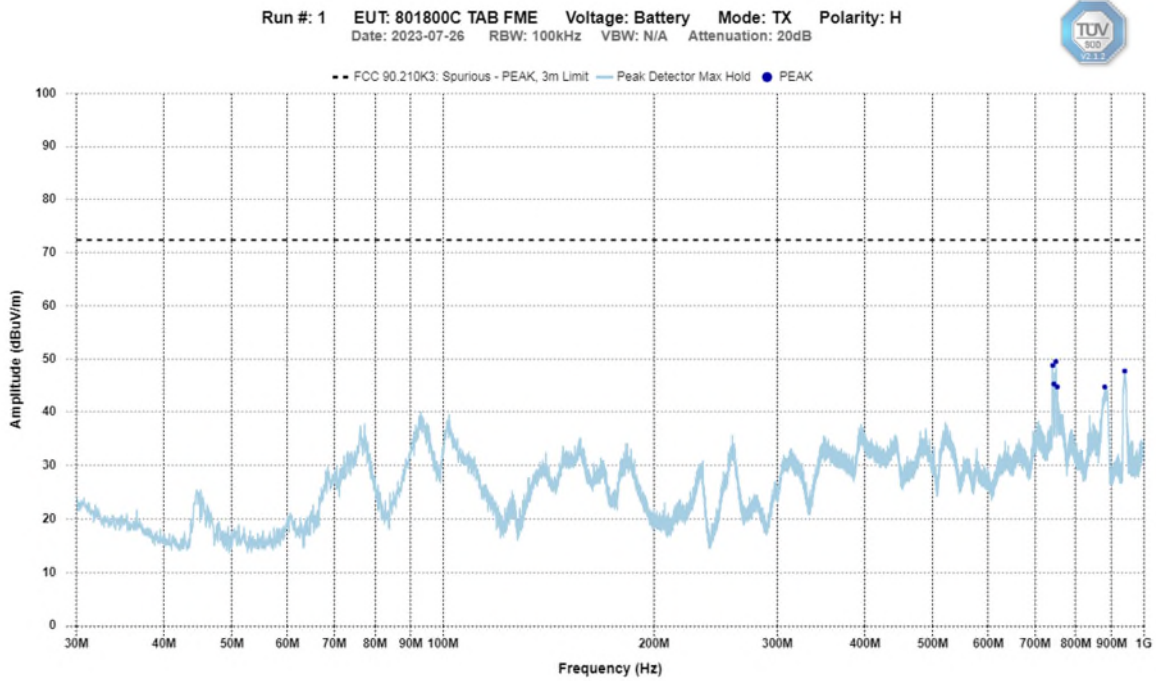

Horizontal – Peak Emission Graph
30 MHz – 1 GHz

Client	Kapsch TrafficCom Canada Inc.	
Product	JANUS™ Front Mount Exterior OBU Model: 801800C-TAB	
Standard(s)	RSS 137 Issue 2:2009 FCC Part 90 Subpart M:2015	

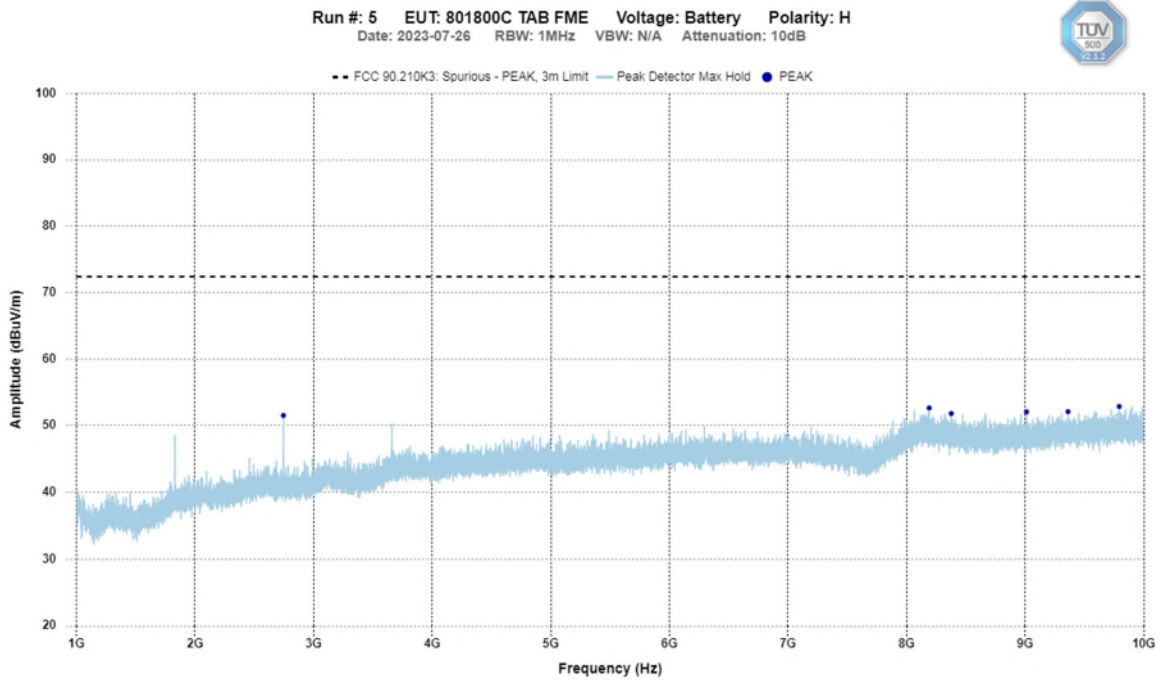

Horizontal – Peak Emission Graph
1 GHz – 10 GHz

Client	Kapsch TrafficCom Canada Inc.	
Product	JANUS™ Front Mount Exterior OBU Model: 801800C-TAB	
Standard(s)	RSS 137 Issue 2:2009 FCC Part 90 Subpart M:2015	

Results

The EUT passed; it meets the Emissions Mask attenuation requirements throughout the frequency range, measured as radiated emissions. No peak emissions were above the limit.

Test Equipment List

Equipment	Model No.	Manufacturer	Last Calibration / Verification Date	Next Calibration / Verification Date	Asset #
Spectrum Analyzer	ESU 40	Rohde & Schwarz	Feb. 11, 2022	Feb. 11, 2024	GEMC 233
BiLog Antenna	3142-C	ETS-Lindgren	Dec. 7, 2022	Dec. 7, 2024	GEMC 8
Horn Antenna 1 – 18 GHz	3117	ETS-Lindgren	Mar. 11, 2022	Mar. 11, 2024	GEMC 340
Attenuator 6 dB	612-6-1	Meca Electronics, Inc	NCR	NCR	GEMC 287
Attenuator 10 dB	6N10W-10	Inmet	NCR	NCR	GEMC 349
Pre-Amp 9 kHz – 1 GHz	LNA 6901	Teseq	Feb. 17, 2023	Feb. 17, 2025	GEMC 168
Pre-Amp 1 – 26.5 GHz	HP 8449B	HP	Mar. 11, 2022	Mar. 11, 2024	GEMC 189
RF Cable <1GHz	LMR-400	LexTec	NCR	NCR	GEMC 274
RF Cable <1GHz	Sucoflex 104A	Huber+Suhner	NCR	NCR	GEMC 271
RF Cable >1GHz	EMC2	MegaPhase	NCR	NCR	GEMC 369
Emissions Software	V2.1.2	TUV SUD Canada, Inc.	NCR	NCR	GEMC 361

Client	Kapsch TrafficCom Canada Inc.	
Product	JANUS™ Front Mount Exterior OBU Model: 801800C-TAB	
Standard(s)	RSS 137 Issue 2:2009 FCC Part 90 Subpart M:2015	

Temperature Frequency Stability

Purpose

The purpose of this test is to ensure that the RF energy unintentionally emitted from the EUT does not exceed the permitted bandwidth during extreme temperature variations. This helps protect radio broadcasts and receivers with spectrum nearby to the equipment under test from unwanted interference. This also helps ensure proper reception of the intended signal by ensuring the transmit frequency is correct in any temperature.

Limit(s) and Method

The methods are given in FCC Part 2.1055. There limits given in FCC Part 90.213.

However, the device meets the following condition:

Fixed non-multilateration transmitters with an authorized bandwidth that is more than 40 kHz from the band edge, intermittently operated hand-held readers, and mobile transponders are not subject to frequency tolerance restrictions.

The EUT is a mobile transponder and therefore is not subject to frequency tolerance restrictions. The test was performed for information purpose.

Frequency tolerances measurements are taken for information purpose. Frequency must be maintained from -30 C to +50 C. The EUT is monitored at each 10 degree increment. At each temperature, the device is checked after a stabilization period required for the device to reach the temperature.

Client	Kapsch TrafficCom Canada Inc.	
Product	JANUS™ Front Mount Exterior OBU Model: 801800C-TAB	
Standard(s)	RSS 137 Issue 2:2009 FCC Part 90 Subpart M:2015	

Measurements

The worst case results are presented, with the frequency shown. The device was checked at each 10 degree increment of temperature.

Temperature (°C)	Measured Frequency (MHz)	Frequency Deviation (PPM)
-30	915.0174	-79.008648
-20	915.026	-69.61066221
-10	915.0492	-44.25795635
0	915.0637	-28.41251519
10	915.0781	-12.67635293
20	915.0897	0
30	915.0955	6.338176465
40	915.0955	6.338176465
50	915.0926	3.169088233

Test Equipment List

Equipment	Model No.	Manufacturer	Last Calibration Date	Next Calibration Date	Asset #
Spectrum Analyzer	ESU 40	Rohde & Schwarz	Feb. 11, 2022	Feb. 11, 2024	GEMC 233
Attenuator 10 dB	8493B	Agilent	NCR	NCR	GEMC 133
Temperature & Humidity Monitor	iTHX-SD	Omega	Feb 1, 2023	Feb 1, 2024	GEMC 282
Temperature & Humidity Chamber	SH-241	Espec	NCR	NCR	CANE196

Client	Kapsch TrafficCom Canada Inc.	
Product	JANUS™ Front Mount Exterior OBU Model: 801800C-TAB	
Standard(s)	RSS 137 Issue 2:2009 FCC Part 90 Subpart M:2015	

Appendix A – EUT Summary

Client	Kapsch TrafficCom Canada Inc.	
Product	JANUS™ Front Mount Exterior OBU Model: 801800C-TAB	
Standard(s)	RSS 137 Issue 2:2009 FCC Part 90 Subpart M:2015	

General EUT Description

Client Details	
Organization / Address	Kapsch TrafficCom Canada Inc 6020 Ambler Drive, Mississauga, Ontario, Canada, L4W 1P1
Contact	Alastair Malarky
Phone	416-451-0223
Email	alastair.malarky@kapsch.net
EUT (Equipment Under Test) Details	
EUT Name	JANUS™ Front Mount Exterior OBU
EUT Model / SN	801800C-TAB
EUT revision	New product
Software version	N/A
Equipment category	902-928 MHz, LMS Non-multilateration, mobile transponder
EUT is powered using	Battery 3.6V Internal to EUT
Transmits RF energy? (describe)	Yes 902-928 MHz, LMS Non-multilateration Listen before Talk – Triggered by part 90 licensed reader Transmits fixed frequency 915 +/- 0.6 MHz Transmits burst OOK Manchester, 500 kbps Internal antenna Rated 3.5 dBm ERP
Basic EUT functionality description	Device responds to specific RF free-space signal (receive) signal and radiates (transmits) short burst of 915 MHz manchester encoded RF free-space signal. It has an integral antenna.
Customer to setup EUT on site?	Yes The EUT requires no setup. The EUT triggering requires setup - see "801800C Test Article Modifications and Instructions" attached
Peripherals required to exercise EUT Ex. Signal generator	Signal generator capable of 20us RF pulses, 133 Hz rate, at 915.75 MHz, Conducted Level >= -8 dBm Radiated source level ~ +40dBm at 3m
Dimensions of product	L 215.9 mm W 46.49 mm H 26.95 mm

For further details for filing purposes, refer to filing package.

Note the EUT is considered to have been received the date of the commencement of the first test, unless otherwise stated. For a close-up picture of the EUT, see 'Appendix B – EUT and Test Setup Photos'.

Page 32 of 33	Report Issued: 8/25/2023	Report File #: 7169013405RF-000
---------------	--------------------------	---------------------------------

Client	Kapsch TrafficCom Canada Inc.	
Product	JANUS™ Front Mount Exterior OBU Model: 801800C-TAB	
Standard(s)	RSS 137 Issue 2:2009 FCC Part 90 Subpart M:2015	

Appendix B – EUT and Test Setup Photos

Refer to the files separate from this test report.