

NOTES, UNLESS OTHERWISE SPECIFIED:

1. CONFIGURE THE READER AS REQUIRED IN ACCORDANCE WITH THE COMMAND CARD PROCEDURE 6090-903. IF NECESSARY, MARK THE FOLLOWING INFORMATION IN AREA SHOWN ON ITEM 7 (PRODUCT LABEL): (INSIDE READER WALL (SEE 6307-303)

A) MODEL NUMBER:

6181 B K T 00 0 0 00 - XYYYY

- CUSTOM CONFIGURATION NUMBERS
- KEYPAD CONFIGURATION OPTIONS
SEE HTOG
- CSN OUTPUT OPTIONS
SEE HTOG
- KEY MANAGEMENT OPTIONS
SEE HTOG
- LED/Speaker CONFIGURATION OPTIONS
SEE HTOG
- HARDWARE OPTIONS
SEE HTOG
- BEZEL COLOR OPTIONS
SEE HTOG
- PRODUCT REVISION
- PRODUCT MODEL NUMBER

B) FINAL ASSEMBLY NUMBER: 6307-300-XX.

C) DATE CODE - SERIAL NUMBER:

WW YY - NNNNN

- SERIAL NUMBER
- YEAR
- WEEK OF YEAR

2. MARK ITEM 5 (SHIPPING LBL):

A) MODEL NUMBER: SEE NOTE 1. A).

B) DATE CODE - LOT NUMBER

WW YY - NNNNN

- LOT NUMBER
- YEAR
- WEEK OF YEAR

3. REMOVE MOUNTING PLATE, PLUG ITEM 6 (MODULE) INTO ITEM 1 (READER). REATTACH MOUNTING PLATE AND APPLY ITEM 7 (LBL, PROD) TO MOUNTING PLATE. PACKAGE REASSEMBLED READER INTO BOX AND APPLY ITEM 3 (SHIPPING LABEL).

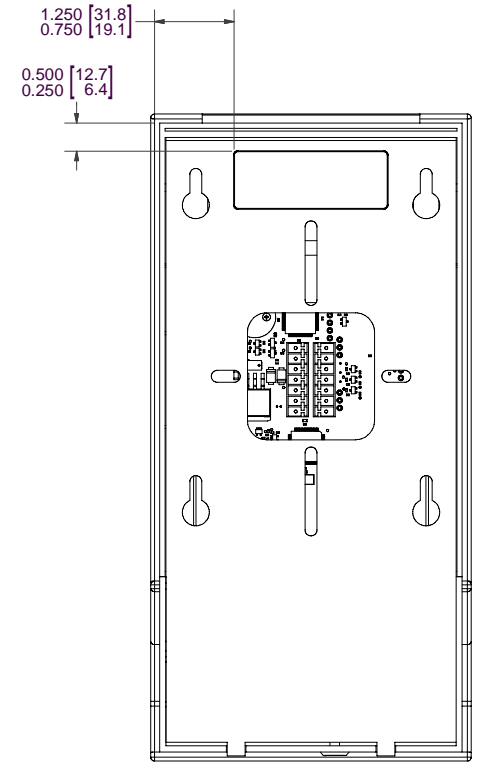
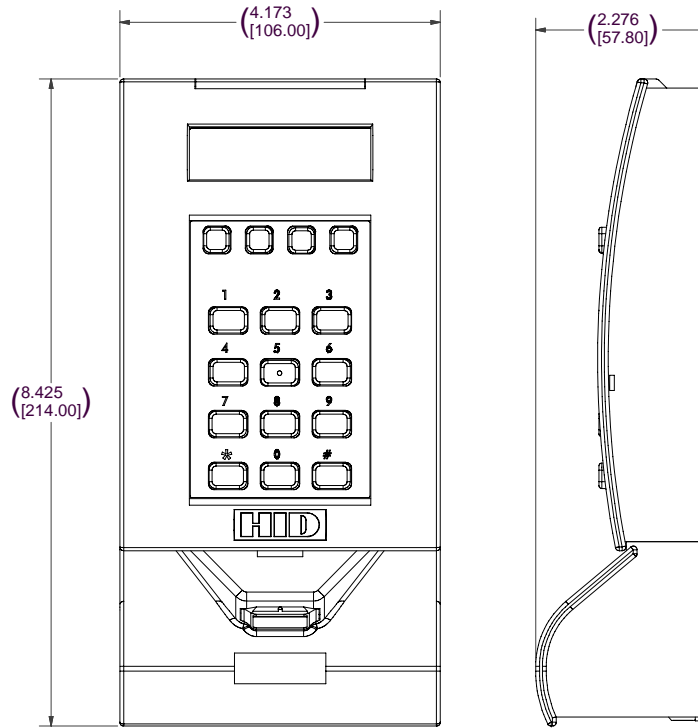
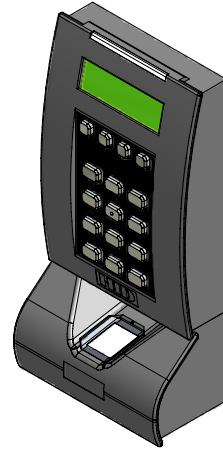
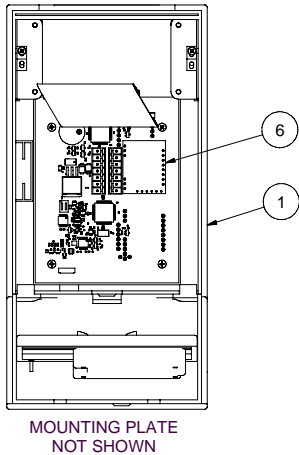

REVISION HISTORY		
REV	ECO#	DESCRIPTION
1	ITG00776	INITIAL DWG
2	ITG00933	UPDATE VIEWS / TITLE BLK / REVISE NOTES
3	ITG01105	ADDED ASSY VIEW / UPDATE NOTES
4	ITG01281	REVISED NOTES 1 & 3 SEE REV 3 FOR WAS / ZONE 3A ITEM 6 WAS ITEM 1 & ITEM 1 WAS ITEM 2
5	ITG01491	ADD PROD LBL LOCATION DIMS

HID GLOBAL CONFIDENTIAL AND PROPRIETARY INFORMATION. THIS DOCUMENT CONTAINS CONFIDENTIAL AND PROPRIETARY INFORMATION, WHICH MAY NOT BE DUPLICATED, PUBLISHED, DISSEMINATED OR DISCLOSED TO UNINTENDED THIRD PARTY RECIPIENTS [OR JUST: "THIRD PARTIES"] OR USED FOR ANY PURPOSE, WITHOUT WRITTEN PERMISSION FROM HID GLOBAL CORPORATION. IF YOU ARE AN UNINTENDED RECIPIENT OF THIS PROPRIETARY INFORMATION OR ARE UNWILLING TO ACCEPT THE ABOVE RESTRICTIONS, PLEASE IMMEDIATELY RETURN THIS DOCUMENT TO HID GLOBAL CORPORATION, 9292 JERONIMO RD., IRVINE, CA 92618-1905.

DIMENSIONS ARE IN INCH/ES [MILLIMETER/S]
UNLESS OTHERWISE SPECIFIED
.XX +/- .01 [.3]
.XXX +/- .005 [.13]
FINISH

DO NOT SCALE DRAWING
SEE SEPARATE APPROVAL LIST
SEE SEPARATE PARTS LIST
THIRD ANGLE PROJECTION
INTERPRET DRAWING PER ANSI/ASME Y14.5M
MATERIAL

IRVINE, CALIFORNIA			
DWG TITLE END ITEM, RWKLB575 ICLASS KEYPAD READER			
SIZE C	CAGE CODE	DWG NO 6181B	REV 5
SCALE: N/A		SHEET: 1 of 1	