

REV	DESCRIPTION	DATE	APPROVED
G	REVISED PER ECO E6030-13		

NOTE: Cover sheet is for Revision Control only, and is not to be sent with document.

REV																							
SHEET	34	35	36	37	38	39	40	41	42	43	44	45	46	47	48	59	50	51					
REV																							
SHEET	16	17	18	19	20	21	22	23	24	25	26	27	28	29	30	31	32	33					
REV STATUS	G	G	G	G	G	G	G	G	G	G	G	G											
OF SHEETS	0	1	2	3	4	5	6	7	8	9	10	11	12	13	14	15							
TOLERANCES	APPROVALS				DATE				HID CORPORATION														
.XX = +/- .03"	DWN G. FOSSEN				072496				IRVINE, CALIFORNIA														
.XXX = +/- .010"	CHK JEBENS				080996				Installation Manual ProxPro Plus Reader														
ANGLES = +/- 1°	APVD MERCADO				080996																		
MATERIAL N/A	APVD EDMISTON				082096																		
FINISH N/A									P/N 6030-900					REV G									
SCALE N/A									SIZE A			SHEET 0 OF 10											



HID CORPORATION

Subsidiary of Palomar Technologies Corporation

Installation Manual – 6030-900 Rev G
ProxPro Plus Wiegand/Clock and Data Reader 6030/8A

Table of Contents

ProxPro Plus System Overview	3
Operation	3
Product Configuration/Ordering Options	3
Installation Notes	4
Cable Notes	4
Installation Procedure	5
Cable Installation	5
Switch Configuration	6
Glass Mount Installation	7
Side Mount Installation	7
Wall Mount Installation	9
Radio Frequency Interference	10
Product Specifications	10
Read Distance	10
Regulatory Requirements (will be applied for)	Error! Bookmark not defined.
Environmental Characteristics	10
Power Requirements	10
Operating Parameters	10

ProxPro Plus System Overview

The ProxPro Plus reader is a self contained proximity reader. This product is derived from the popular ProxPro Reader with added features that include a side cable exit for glass mount locations, and a longer read range.

The two piece polycarbonate enclosure has a cable grommet that seals the cable for the side exit option and a feed through strain relief connector for the rear exit option. A bi-color LED and beeper enhance user feedback. Configurable open collector data outputs provide the Wiegand data to the Host. An internal DIP switch makes the configuration of the outputs, beeper and LED control options simple. Installation of the ProxPro Plus Reader consists of running cable, making wire connections, verifying the DIP switch settings and mounting.

Operation

Access Cards (badges, tags, transponders) are presented to the front or back of the ProxPro Plus reader. The LED is red when the reader is ready to read an access card. The LED turns green and the beeper sounds when the access card is read and the message is transmitted to the Host computer or interface panel. The system is ready for another access card as soon as the LED returns to red. There is an anti-pass-back delay of about one second before it will read the same card. The LED flash is a ¼ of a second long. The operation of the LED and beeper may be controlled by the Host. If Host controlled, the operation will depend on the programmed timing of the Host.

Product Configuration/Ordering Options

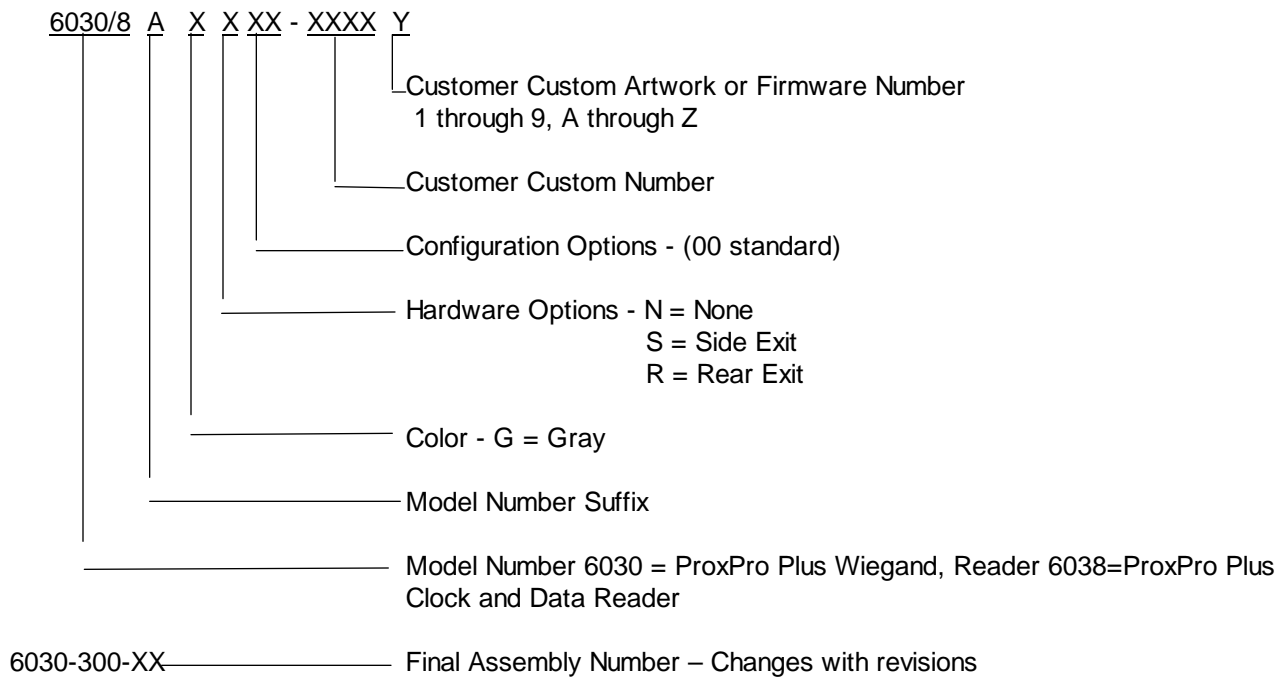

- Standard Wiegand Part Number = 6030AGS00 is a ProxPro Plus, Wiegand, Gray, Side cable exit.

Installation Notes

Near Metal - The typical read distance specification (9.5 inches) refers to operation without metal in the vicinity of the Reader. Use the metal compensation Jumper, P1, if mounting within 2" of a metal surface.

Place the jumper on P1 between pins 1 and 2 when mounting to a metallic surface or to a junction box with a metal cover plate. Otherwise, the jumper should be between pins 2 and 3, the default position (see figure 1).

The ProxPro Plus generates a magnetic field on both sides of the reader. Any metal that conducts electricity, especially metal that contains iron, steel or copper, will interfere with the field and reduce the effective read range (this will happen even if the metal is behind the Reader).

For optimum performance, the Reader should be mounted at least 4 inches away from any metallic surface 7"x7" or larger. Incidental metal such as aluminum and steel studs and conduit can be compensated. Avoid installing conduit and other metal hardware within 1 inch of the back of the Reader.

Power Supply - The ProxPro Plus Reader can be operated over the full range of 10-28.5VDC, 150mA. The Read distance will be slightly higher on 24VDC when compared to 12VDC. A linear supply is recommended. Noise from devices such as switching power supplies, computer monitors and arc welders can reduce the read range or make the unit inoperable. Keep these devices at least 10 ft away from the Reader.

Testing - After wiring the Reader and power supply, the Reader is ready to be tested. Power up the Reader and the LED and Beeper will flash and beep 3 times in a sequence of two short delays and one long delay. This indicates that the micro-controller unit is working properly. Present an ID card to the Reader and the LED should momentarily turn green and the Beeper will sound, indicating a read of the card. If the Reader LED/Beeper is controlled by the Host refer to the Host description of the LED operation.

Tamper Switch - Connect the tamper switch to the Host, if available on the Host. When the cover is removed, the tamper switch is released. The switch contacts available on pins 10 and 11 are either normally open or normally closed dependent upon the position of the jumper on P3. Install the jumper to connect pins 1 and 2 if you need the normally open contact. Select the 2-3 position if you need the normally closed contacts. The normally open and normally closed refer to the condition of the switch when the case is open. The contacts are rated for 50 mA at 28.5 VDC.

Cable Notes

1. When using 5 conductor cable, the power supply and Host must have a common ground (voltage reference).
2. 6 conductor cable is required when using the "Hold" function (Alpha 1296 C or equivalent).
3. 7 conductor cable is required when the "Hold" function is used, and the power supply and Host "ground" are separate (Alpha 1297 C or equivalent).
4. The Wiegand interface cable should be restricted to a length 500 feet. The inner diameter of the cable grommet will accommodate a cable with an outer diameter of .300 inches (maximum).
5. The Cable shield should be connected to the Return Ground on Reader TB1- 5, and left floating at the panel or power supply end of the cable. This configuration is the best for shielding the reader cable from external interference and reducing the likelihood of the Reader causing interference.

Installation Procedure

Cable Installation

Preparation - Determine the desired mounting location for the reader. The reader can be mounted directly to a glass panel using tape (Glass Mount), to the mullion of a glass panel using a side mount bracket (Side Mount), or to an electrical gang box (Wall Mount).

Install Cable - Route the interface cable from the mounting location to the power supply and/or the Host. Refer to "Cable Notes" to determine the best cable to use.

Cable Preparation - Prepare the cable by cutting the cable jacket back 2 inches and strip the wires 1/4 inch. Tinning the wires is not required.

Cable Connections - Disassemble the reader by removing the 4 #8 screws from the back. For the side mount reader feed the cable through the mounting bracket and the 1/4" diameter grommet, this should be a tight fit. For the rear mount reader feed the cable through the strain relief connector and tighten down. Connect the wires to the terminal strip with the minimum length necessary; do not leave extra loops of wire inside the Reader housing. Connect the Reader to the Host according to the terminal description of TB1 below. The descriptions are also labeled on the PCB guard in the reader. Connect the drain line of the shield to terminal 5 (Return). If the drain line is bare, cover it with heat shrink or tape to avoid short circuits to the other wires. The host end of the drain line should be left open.

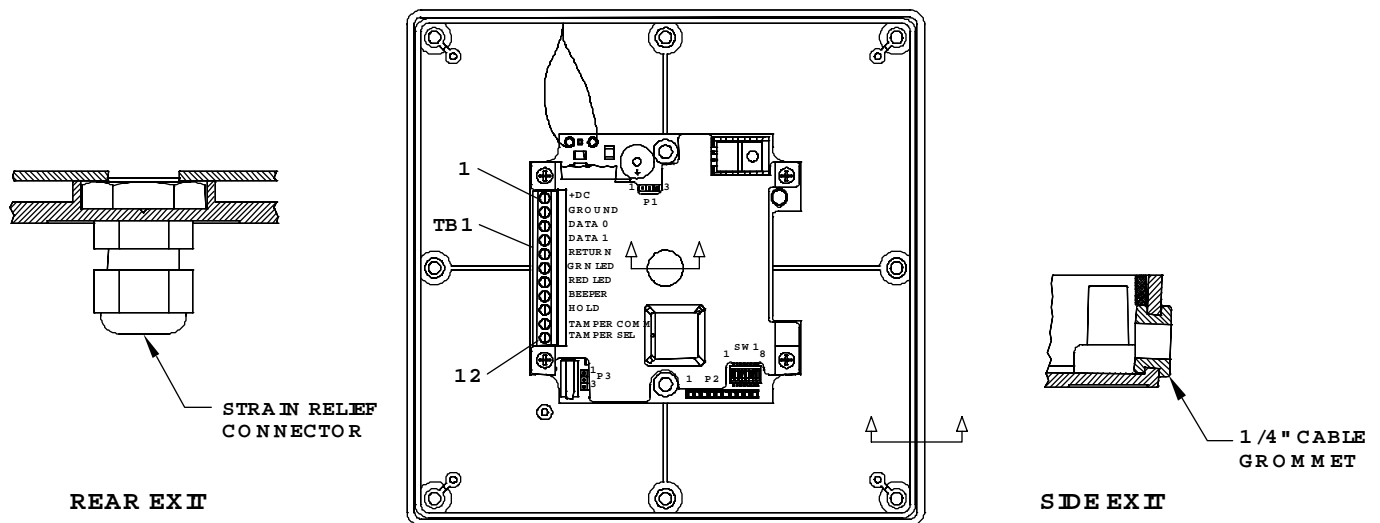

1	2	3	4	5	6	7	8	9	10	11
+DC	Ground	Data0	Data1	Return (Shield)	Green LED	Red LED	Beeper	Hold	Tamper Common	Tamper Select
Red	Black	Green	White	Drain	Orange	Brown	Yellow	Blue	---	---

FIGURE 1
Cable Terminal Connections

Switch Configuration

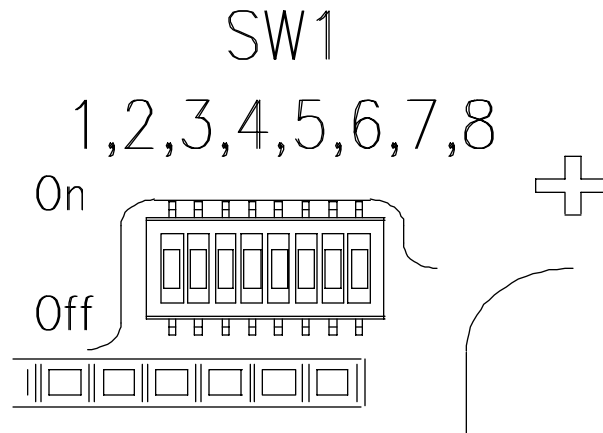

FIGURE 2

Switch description and default settings:

SW1-1 Hardware Identity

When set in the "ON" position the unit is configured for "Wiegand" Interface. The "OFF" position configures the unit for "Clock and Data" Interface.

SW1-2 Beeper Control - On

The Beeper may be enabled or disabled to sound when an access card is read. When enabled, the audible tone is sounded when the a card is successfully read. When the Beeper is disabled, the only method to activate the Beeper is to use the external Beeper control line. The Beeper will turn on when the control line is switched to ground. Switch 2 in the "on" position enables the beeper (the default).

SW1-3 Green LED Control

The Green LED can be configured to turn on, or not turn on when an access card is read. Switch 3 in the "off" position selects the Green LED to be turned on (the default).

SW1-4 Keyboard Operation - Off

Not Available.

SW1-5 LED Dual mode - Off

The default mode for the LED control is the single line control. The LED is normally red and when the access control card is read the LED flashes Green. When "On", this mode allows the user independent control of both Red and Green LED's. This is referred to as the Dual LED mode. When the Red or Green LED Control line is switched to ground the respective LED is turned ON. If both LED's are on the LED appears to glow amber.

SW1- 6 and 7 Data0 and Data1 output pull-up resistor - On, On

The data outputs may be configured as open collector or have pull-ups connected to 5VDC through 1kOhm resistors in the reader. The default (standard) configuration is pull-ups connected, with switches 6 and 7 "On" . Note: When the outputs are configured as open collector, the host panel should provide pull-ups and bias voltage at the panel inputs.

SW1-8

Not used

Glass Mount Installation

Parts List

- | | |
|---|---------------------------|
| 1) ProxPro Plus Reader, Side Cable Exit | qty 1 ea. (included) |
| 2) This Installation Manual | qty 1 ea. (included) |
| 3) Adhesive Foam Tape | qty 3 ft (included) |
| 4) 5 conductor Alpha 1295 C or equivalent. See cable notes. | User supplied |
| | As required, up to 500' |
| 5) Power Supply Requirements | User supplied |
| | Linear, 10-28.5VDC, 120mA |

- Replace cover of reader ensuring that the LED is lined up with the LED lens on the cover.
- Apply labels such that when the reader is mounted they are right side up.
- Apply double sided tape to the tape track on either the front or the back, depending on which side of the glass you are mounting, and secure to glass.

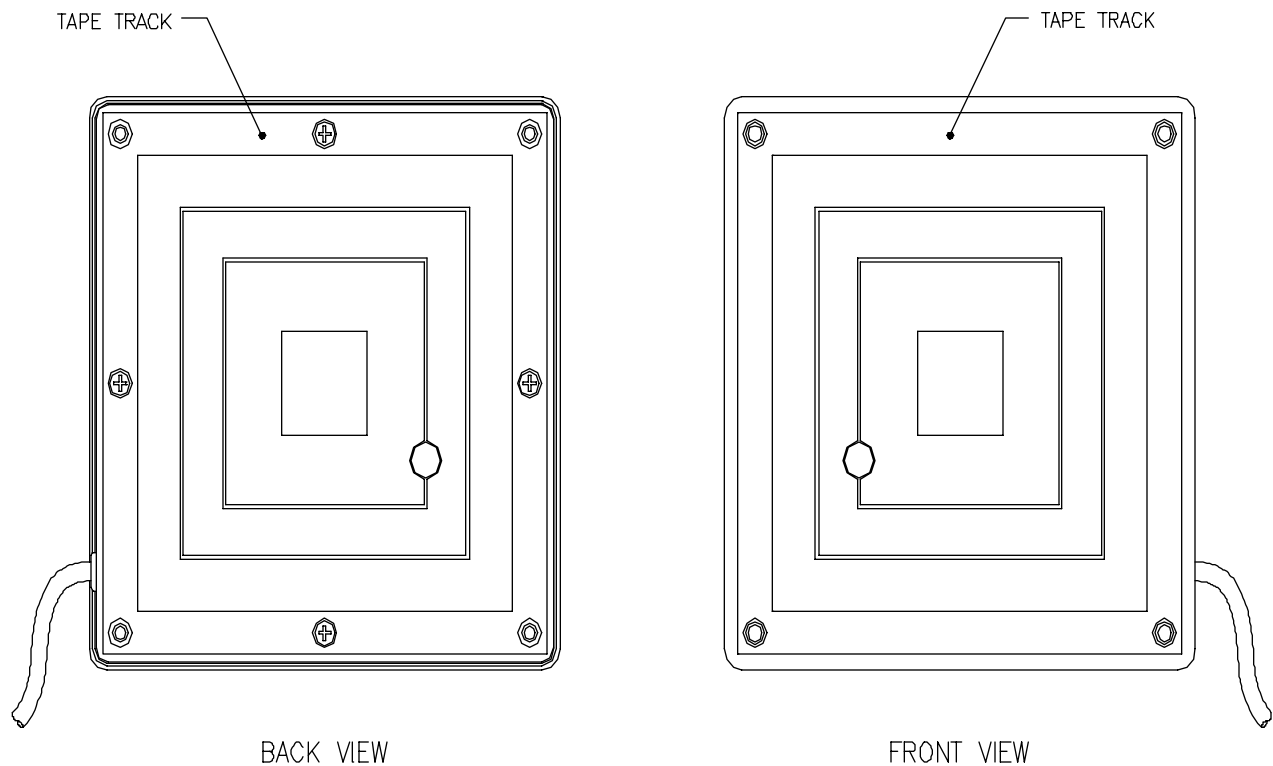

FIGURE 3

Side Mount Installation

Parts List

- | | |
|---|---------------------------|
| 1) ProxPro Plus Reader, Side Cable Exit | qty 1 ea. (included) |
| 2) This Installation Manual | qty 1 ea. (included) |
| 3) Mounting Bracket | qty 1 ea. (included) |
| 4) Screw, self tapping, 8-18 x .750, flat head 100° | qty 2 ea. (included) |
| 5) Screw, machine, 6-32 x .750, pan head, blk | qty 2 ea. (included) |
| 6) Washer, flat #6, black | qty 2 ea. (included) |
| 7) 5 conductor Alpha 1295 C or equivalent. See cable notes. | User supplied |
| | As required, up to 500' |
| 8) Power Supply Requirements | User supplied |
| | Linear, 10-28.5VDC, 120mA |

- Mount bracket to mullion using 8-18 x .750 self tapping screws as close to glass as possible.
- Apply labels such that when the reader is mounted they appear right side up.
- Slip the reader over the standoffs on the mounting bracket and secure using the 6-32 x .750 machine screws and the washers

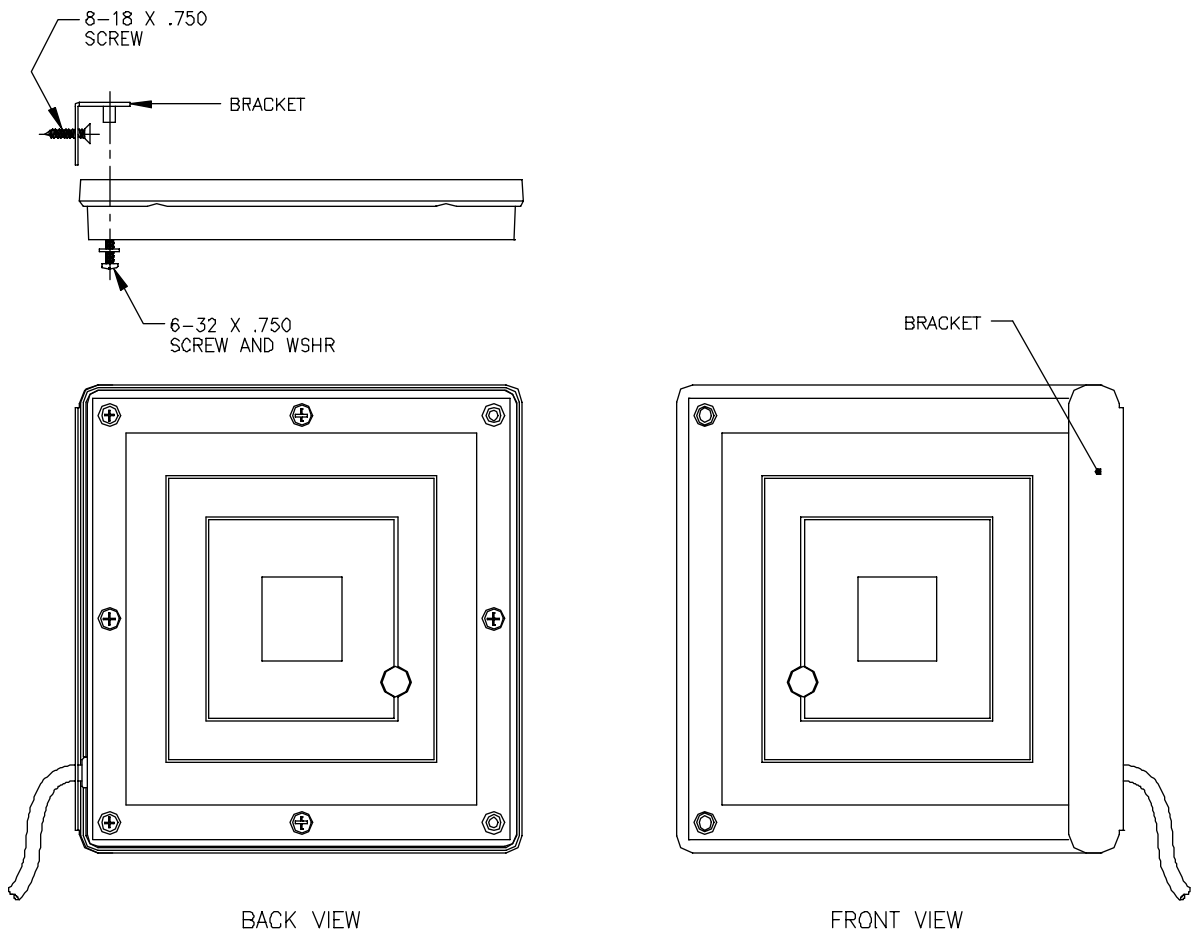

FIGURE 4

Wall Mount Installation parts List

- 1) ProxPro Plus Reader, Rear Cable Exit
- 2) This Installation Manual
- 3) Screw, self tapping, 6-32 x 1.00, pan head
- 4) Screw, machine, 8-32 x .875, flat head 82°, black
- 5) Nut, clinch, black
- 6) 5 conductor Alpha 1295 C or equivalent. See cable notes.
- 7) Power Supply Requirements

qty 1 ea (included)
 qty 1 ea (included)
 qty 2 ea (included)
 qty 4 ea (included)
 qty 4 ea (included)
 User supplied
 As required, up to 500'
 User supplied
 Linear, 10-28.5VDC, 120mA

When using a gang box:

- Drill a $\varnothing .188$ hole in the 2 locations shown in figure 5.
- Insert the 6-32 clinch nuts 4 places in back.
- Mount reader to gang box using 6-32 self tapping screws.
- Return cover using 8-32 machine screws. Ensure that the LED lens on the cover is lined up with the LED.
- Apply "HID" label such that it is right side up.

When not using a gang box:

- Return cover to base using screws provided with reader. Ensure that the LED lens on the cover is lined up with the LED.
- Mount reader to wall using the 4 corner holes in the case.
- Apply the "HID" label such that it is right side up.

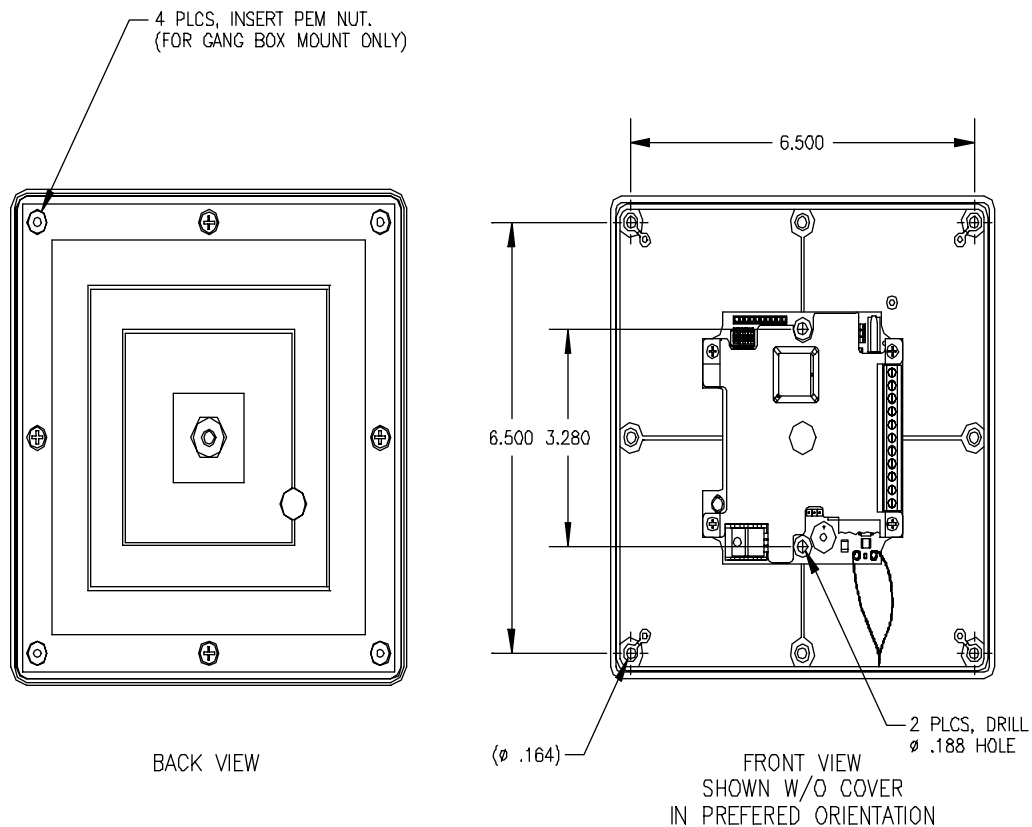

FIGURE 5

Radio Frequency Interference

Motors and electronic devices generate RF noise that may interfere with the reception of the signal from a access card. The effect of RF noise is typically a reduction of read range. The Glass Mount ProxPro is susceptible to RF interference as are all devices that receive RF signals. Examples are radios, televisions, and cellular phones. The read range is affected by the amount of interference (noise) in the area. The Glass Mount ProxPro should not be mounted within ten feet of any monitors (VDTs or CRTs) because the scan frequencies of most monitors include frequencies that may interfere with the signal received from the access control cards.

Product Specifications

Read Distance

➤ Overall Operating Limits (12VDC - minimum)	8.5 inches (21.6 cm)
➤ Non-Metallic Mounting (12VDC - typical)	9.5 inches (37.4 cm)
➤ Mounted on Metal (12VDC - typical)	6.0 inches (15.2 cm)
➤ Overall Operating Limits (24VDC - minimum)	9.0 inches (6.3 cm)
➤ Non-Metallic Mounting (24VDC - typical)	10.5 inches (22.9 cm)
➤ Mounted on Metal (24VDC - typical)	7.0 inches (17.8 cm)

Environmental Characteristics

➤ Designed for listing under UL 294 "Standard for Access Control System Units"	
➤ Operating Temperature Range	-30°C to 65°C (-22°F to 150°F)
➤ Storage Temperature Range	-40°C to 85°C (-40°F to 185°F)
➤ Operating Humidity Range	5% to 95% non-condensing
➤ Operating Vibration Limit	.04 g ² /Hz 20-2000Hz
➤ Operating Shock Limit	30g, 11mS, Half Sine
➤ Enclosure Material	UL Recognized Polycarbonate
➤ Weight	13oz (364gms)

Power Requirements

➤ Power supply	Linear type recommended
➤ Operating Voltage Range	10VDC -28.5VDC
➤ Maximum Average Current 5V/12V	150mA
➤ Transient Protection (all terminals)	UL294
➤ Reverse Voltage Protection	YES
➤ Input Voltage (maximum data-0/1 lines)	28.5VDC
➤ Input Voltage (maximum interface lines)	28.5VDC

Operating Parameters

➤ Excitation Frequency	125KHz
➤ Duty Cycle (alternate power level rate)	20% @ 60mS period
➤ Read and Report Speed (26 bit Wiegand Card)	175mS
➤ Maximum Cable Distance to Host	500 feet (152 meters)
➤ LED Type	Bi-colored Red/Green
➤ LED Operation (host control of red/green)	<.5V on LED control line
➤ Beeper Operation (host control)	<.5V on beeper line
➤ LED Control (default)	internal/single
➤ Beeper Control (default)	Beeper enabled
➤ Anti-Pass Back Delay (default)	1 second
➤ Wiegand Data Pulse Widths (default)	40uS
➤ Wiegand Data Interval (default)	2mS

Note: The above are recommended installation procedures. All local, state and national electrical codes have precedence