

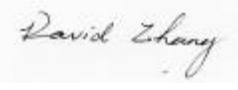

# RF TEST REPORT





Report No.: FCC\_RF\_SL14070701-HID-019\_RFID Rev1.0  
Supersede Report No.: FCC\_RF\_SL14070701-HID-019\_RFID

Applicant	HID Global Corporation		
Product Name	UHF RFID Reader		
Model No.	U90.915		
Test Standard	47CFR15.247: 2013, RSS-210 Issue8: 2010		
Test Method	ANCI C63.4:2009 DA 00-705 Measurement Guidelines for FHSS		
FCC ID	JQ6-ICLASSU90		
IC ID	2236B-ICLASSU90		
Date of test	07/15/2014 - 07/18/2014		
Issue Date	08/14/2014		
Test Result	<u>Pass</u>	Fail	
Equipment complied with the specification			[ x ]
Equipment did not comply with the specification			[ ]
			
David Zhang		Nima Molaei	
Test Engineer		Engineer Reviewer	
This test report may be reproduced in full only Test result presented in this test report is applicable to the tested sample only			

Issued By:  
SIEMIC Laboratories  
775 Montague Expressway, Milpitas, 95035 CA



775 Montague Expressway, Milpitas, CA 95035, USA • Phone: (+1) 408 526 1188 • Facsimile (+1) 408 526 1088

Visit us at: [www.siemic.com](http://www.siemic.com); Follow us at:    

## Laboratory Introduction

SIEMIC, headquartered in the heart of Silicon Valley, with superior facilities in US and Asia, is one of the leading independent testing and certification facilities providing customers with one-stop shop services for Compliance Testing and Global Certifications.



In addition to testing and certification, SIEMIC provides initial design reviews and compliance management throughout a project. Our extensive experience with China, Asia Pacific, North America, European, and International compliance requirements, assures the fastest, most cost effective way to attain regulatory compliance for the global markets.

### Accreditations for Conformity Assessment

Country/Region	Accreditation Body	Scope
USA	FCC, A2LA	EMC , RF/Wireless , Telecom
Canada	IC, A2LA, NIST	EMC, RF/Wireless , Telecom
Taiwan	BSMI , NCC , NIST	EMC, RF, Telecom , Safety
Hong Kong	OFTA , NIST	RF/Wireless ,Telecom
Australia	NATA, NIST	EMC, RF, Telecom , Safety
Korea	KCC/RRA, NIST	EMI, EMS, RF , Telecom, Safety
Japan	VCCI, JATE, TELEC, RFT	EMI, RF/Wireless, Telecom
Mexico	NOM, COFETEL, Caniety	Safety, EMC , RF/Wireless, Telecom
Europe	A2LA, NIST	EMC, RF, Telecom , Safety

### Accreditations for Product Certifications

Country	Accreditation Body	Scope
USA	FCC TCB, NIST	EMC , RF , Telecom
Canada	IC FCB , NIST	EMC , RF , Telecom
Singapore	iDA, NIST	EMC , RF , Telecom
EU	NB	EMC & R&TTE Directive
Japan	MIC (RCB 208)	RF , Telecom
HongKong	OFTA (US002)	RF , Telecom

**CONTENTS**

**1 REPORT REVISION HISTORY .....4**

**2 EXECUTIVE SUMMARY .....5**

**3 CUSTOMER INFORMATION .....5**

**4 TEST SITE INFORMATION .....5**

**5 MODIFICATION .....5**

**6 EUT INFORMATION .....6**

6.1 EUT Description .....6

6.2 Radio Description .....7

6.3 EUT test modes/configuration Description.....7

6.4 EUT Photos - External .....8

6.5 EUT Photos - Internal .....9

6.6 EUT Test Setup Photos .....10

**7 SUPPORTING EQUIPMENT/SOFTWARE AND CABLING DESCRIPTION.....11**

7.1 Supporting Equipment .....11

7.2 Test Software Description .....11

**8 TEST SUMMARY .....12**

**9 MEASUREMENT UNCERTAINTY .....13**

**10 MEASUREMENTS, EXAMINATION AND DERIVED RESULTS .....14**

10.1 Antenna Requirement.....14

10.2 Conducted Emissions.....15

10.3 20dB Bandwidth .....18

10.4 99% Occupied Bandwidth .....21

10.5 Number of Hopping Channel.....23

10.6 Peak Output Power .....25

10.7 Channel Separation .....28

10.8 Time of Occupancy.....31

10.9 100 KHz Bandwidth of Frequency Band Edge.....34

10.10 Radiated Emissions below 1GHz.....36

10.11 Radiated Spurious Emissions above 1GHz.....38

**ANNEX A. TEST INSTRUMENT.....40**

**ANNEX B. USER MANUAL, BLOCK & CIRCUIT DIAGRAM .....41**

**ANNEX C. SIEMIC ACCREDITATION .....42**

## 1 Report Revision History

Report No.	Report Version	Description	Issue Date
FCC_RF_SL14070701-HID-019_RFID	None	Original	07/25/2014
FCC_RF_SL14070701-HID-019_RFID Rev1.0	Rev1.0	Update calculation for dwell time	08/14/2014

## 2 Executive Summary

The purpose of this test program was to demonstrate compliance of following product

Company: HID Global Corporation  
Product: UHF RFID Reader  
Model: U90.915

against the current Stipulated Standards. The specified model product stated above has demonstrated compliance with the Stipulated Standard listed on 1<sup>st</sup> page.

## 3 Customer information

Applicant Name	HID Global Corporation
Applicant Address	15370 Barranca Parkway Irvine, CA 92618
Manufacturer Name	HID Global Corporation
Manufacturer Address	10385 Westmoor Drive, Suite 300, Westminster, CO 80021

## 4 Test site information

Lab performing tests	SIEMIC Laboratories
Lab Address	775 Montague Expressway, Milpitas, CA 95035
FCC Test Site No.	881796
IC Test Site No.	4842D-2
VCCI Test Site No.	A0133

## 5 Modification

Index	Item	Description	Note
-	-	-	-

## 6 EUT Information

### 6.1 EUT Description

Product Name	UHF RFID Reader
Model No.	U90.915
Trade Name	HID
Serial No.	N/A
Input Power (RFID)	12Vdc
Power Adapter Manu/Model	N/A
Power Adapter SN	-
Hardware version	N/A
Software version	N/A
Date of EUT received	07/15/2014
Equipment Class/ Category	Class B
Clock Frequencies	18.432 MHz, 20 MHz and 25 MHz
Port/Connectors	RJ-45, Signal, Relays
Remark	NONE

## 6.2 Radio Description

### Spec for Radio -

Radio Type	UHF RFID
Operating Frequency	902.75-927.25 MHz
Modulation	ASK
Antenna Type	Internal PCB antenna
Antenna Gain	5.37 dBi
Channel Separation	500 KHz
Number of Channels	50

## 6.3 EUT test modes/configuration Description

### Test mode

Test Mode		Note
Test mode1	Below 1GHz-Mode1: UHF cont TX at 915.25MHz	-
Test mode2	Above 1GHz-Mode1: UHF cont TX at 902.75MHz	-
Test mode3	Above 1GHz-Mode2: UHF cont TX at 915.25MHz	-
Test mode4	Above 1GHz-Mode3: UHF cont TX at 927.25MHz	-
Test mode5	-	-
Test mode6	-	-
Test mode7	-	-
Test mode8	-	-
Test mode9	-	-
Remark: NONE		



**6.4 EUT Photos - External**

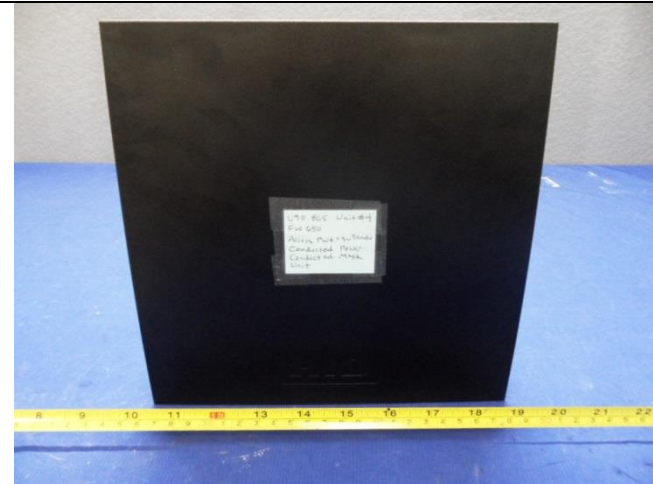

**EUT – Front View**



**EUT – Rear View**

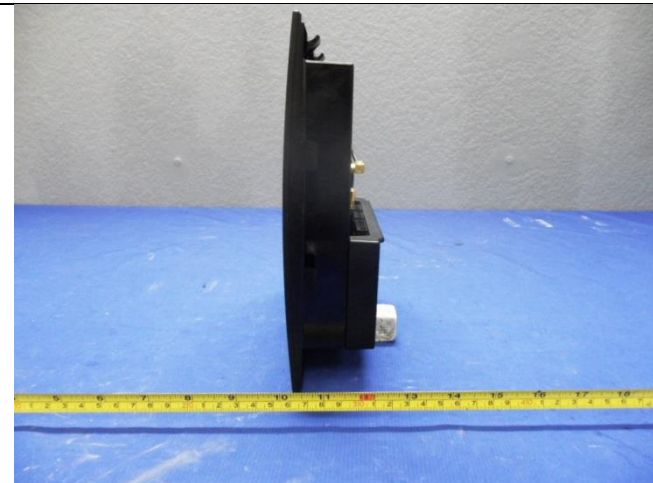

**EUT – Left View**

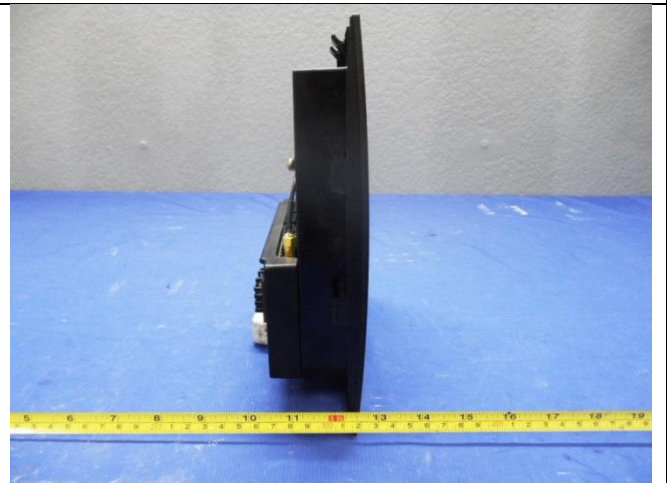

**EUT – Right View**



**EUT – Top View**



**EUT – Bottom View**



**6.5 EUT Photos - Internal**



**EUT With Cover**

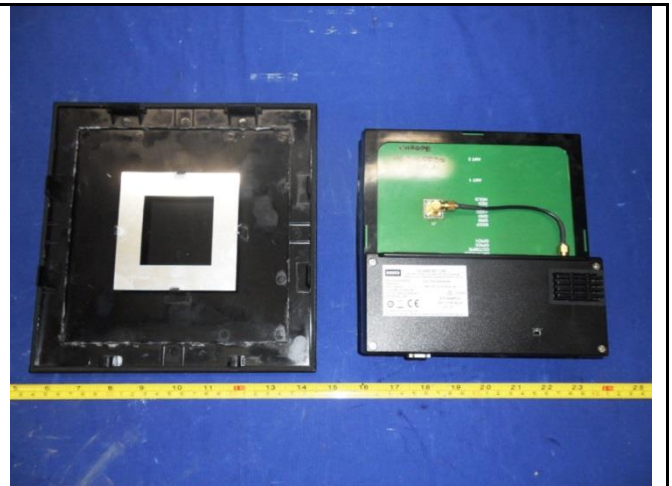

**EUT Without cover**

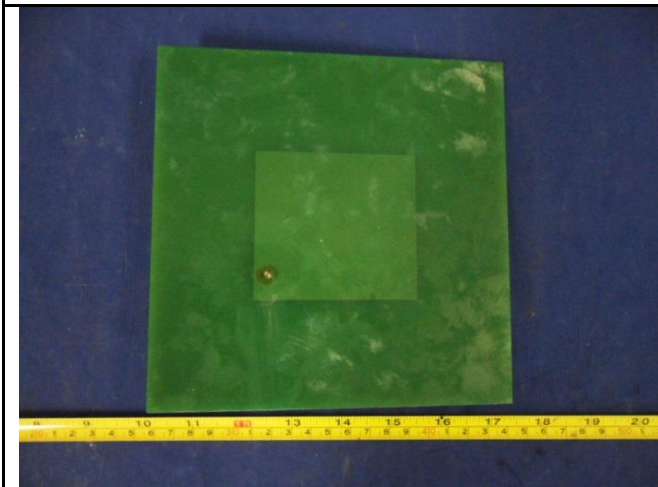

**RFID Antenna - Front View**

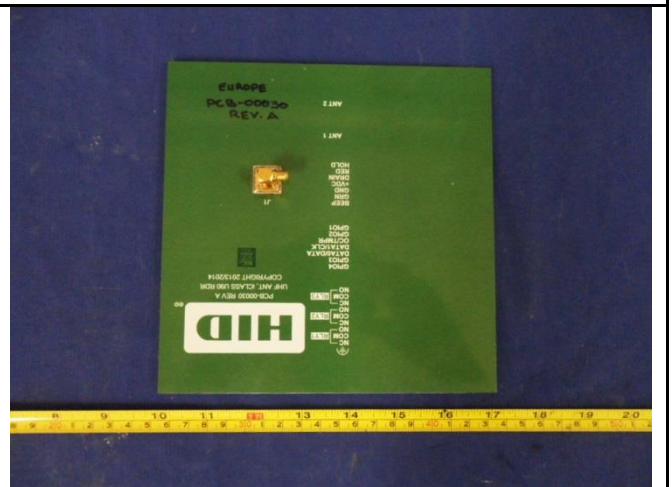

**RFID Antenna - Rear View**

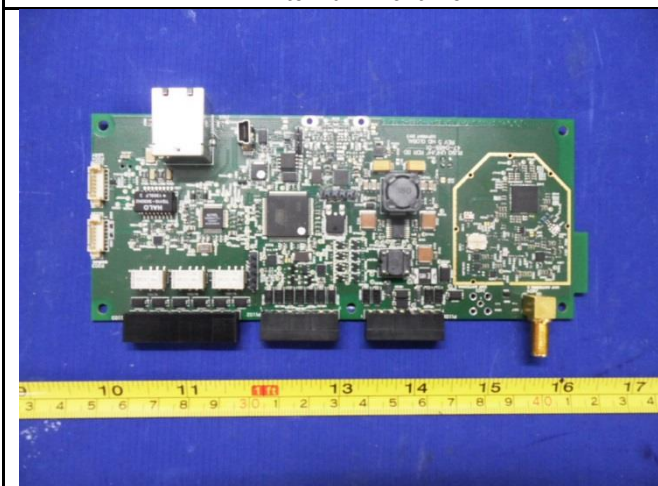

**PCB Controller - Top View**

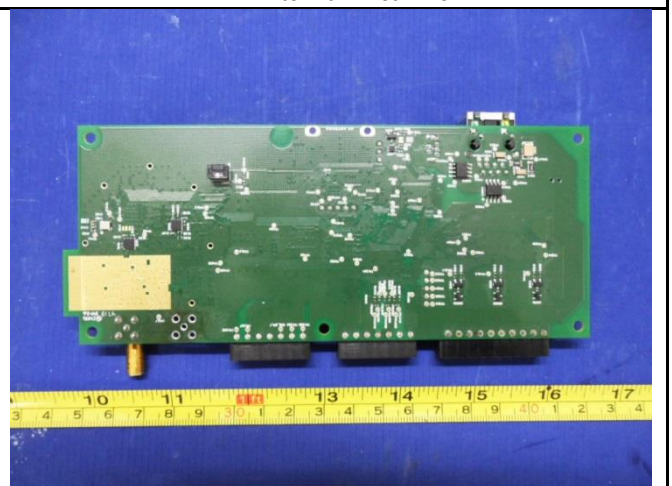

**PCB Controller - Rear View**



**6.6 EUT Test Setup Photos**



**AC Line Conducted Emissions – Front View**



**AC Line Conducted Emissions – Rear View**

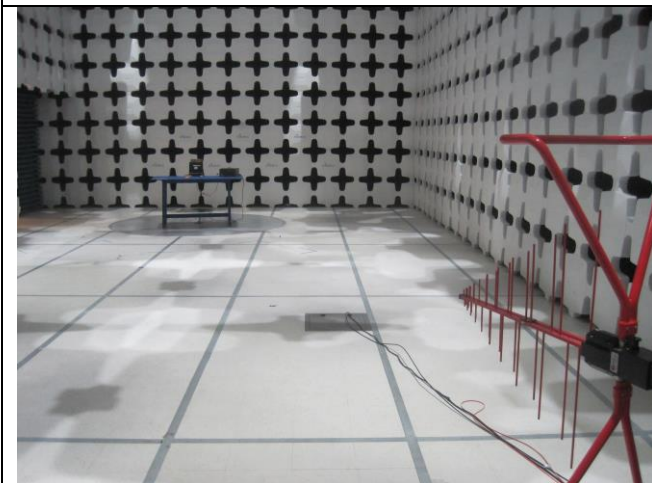

**Radiated Emissions (<1GHz) – Front View**

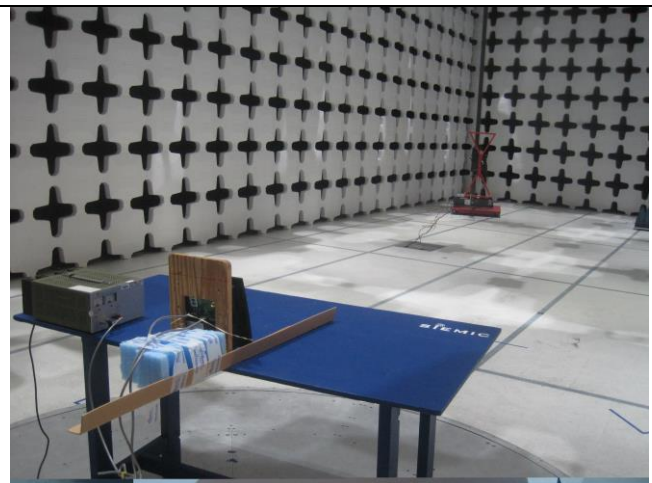

**Radiated Emissions (<1GHz) – Rear View**



**Radiated Emissions (>1GHz) – Front View**

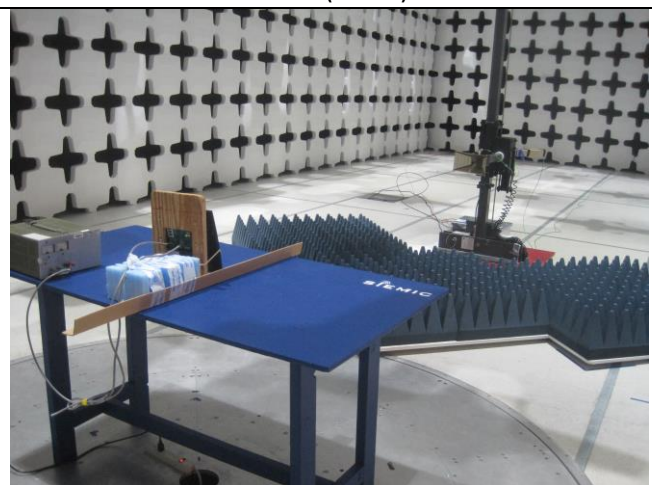

**Radiated Emissions (>1GHz) – Rear View**

## 7 Supporting Equipment/Software and cabling Description

### 7.1 Supporting Equipment

Item	Supporting Equipment Description	Model	Serial Number	Manufacturer	Note
1	Laptop	Type2686	E-A012-03-0857(B)	IBM	-

### 7.2 Test Software Description

Test Item	Software	Description
-	-	-

## 8 Test Summary

Test Item	Test standard		Test Method/Procedure		Pass / Fail
Restricted Band of Operation	FCC	15.205	FCC	ANSI C63.4 – 2009 FCC Public Notice DA 00-705	<input checked="" type="checkbox"/> Pass <input type="checkbox"/> N/A
	IC	RSS 210 (2.2)	IC	-	
AC Conducted Emissions Voltage	FCC	15.207(a)	FCC	ANSI C63.4 – 2009	<input checked="" type="checkbox"/> Pass <input type="checkbox"/> N/A
	IC	RSS Gen (7.2.2)	IC	-	

Test Item	Test standard		Test Method/Procedure		Pass / Fail
Channel Separation	FCC	15.247 (a)(1)	FCC	FCC Public Notice DA 00-705	<input checked="" type="checkbox"/> Pass <input type="checkbox"/> N/A
	IC	RSS210 (A8.1)	IC	-	
Occupied Bandwidth	FCC	15.247(a)(1)	FCC	FCC Public Notice DA 00-705	<input checked="" type="checkbox"/> Pass <input type="checkbox"/> N/A
	IC	RSS210(A8.1)	IC	-	
Bandwidth	FCC	15.247(a)(2)	FCC	FCC Public Notice DA 00-705	<input checked="" type="checkbox"/> Pass <input type="checkbox"/> N/A
	IC	RSS210 (A8.2)	IC	-	
Number of Hopping Channels	FCC	15.247(a)(1)	FCC	FCC Public Notice DA 00-705	<input checked="" type="checkbox"/> Pass <input type="checkbox"/> N/A
	IC	RSS210(A8.1)	IC	-	
Band Edge and Radiated Spurious Emissions	FCC	15.247(d)	FCC	FCC Public Notice DA 00-705	<input checked="" type="checkbox"/> Pass <input type="checkbox"/> N/A
	IC	RSS210(A8.5)	IC	-	
Time of Occupancy	FCC	15.247(a)(1)	FCC	FCC Public Notice DA 00-705	<input checked="" type="checkbox"/> Pass <input type="checkbox"/> N/A
	IC	RSS210(A8.1)	IC	-	
Output Power	FCC	15.247(b)	FCC	FCC Public Notice DA 00-705	<input checked="" type="checkbox"/> Pass <input type="checkbox"/> N/A
	IC	RSS210 (A8.4)	IC	-	
Receiver Spurious Emissions	FCC	15.247(d)		FCC Public Notice DA 00-705	<input checked="" type="checkbox"/> Pass <input type="checkbox"/> N/A
	IC	RSS Gen (4.8)		-	
Antenna Gain > 6 dBi	FCC	15.247(e)	FCC	-	<input type="checkbox"/> Pass <input checked="" type="checkbox"/> N/A
	IC	RSS210(A8.4)	IC	-	
Power Spectral Density	FCC	15.247(e)	FCC	-	<input type="checkbox"/> Pass <input checked="" type="checkbox"/> N/A
	IC	RSS210(A8.3)	IC	-	
Hybrid System Requirement	FCC	15.247(f)	FCC	-	<input type="checkbox"/> Pass <input checked="" type="checkbox"/> N/A
	IC	RSS210(A8.3)	IC	-	
Hopping Capability	FCC	15.247(g)	FCC	-	<input type="checkbox"/> Pass <input checked="" type="checkbox"/> N/A
	IC	RSS210(A8.1)	IC	-	
Hopping Coordination Requirement	FCC	15.247(h)	FCC	-	<input type="checkbox"/> Pass <input checked="" type="checkbox"/> N/A
	IC	RSS210(A8.1)	IC	-	
RF Exposure requirement	FCC	15.247(i)	FCC	-	<input type="checkbox"/> Pass <input checked="" type="checkbox"/> N/A
	IC	RSS Gen(5.5)	IC	-	
Remark	<ol style="list-style-type: none"> <li>All measurement uncertainties do not take into consideration for all presented test results.</li> <li>The applicant shall ensure frequency stability by showing that an emission is maintained within the band of operation under all normal operating conditions as specified in the user's manual.</li> </ol>				

## 9 Measurement Uncertainty

Test Item	Frequency Range	Description	Uncertainty
Band Edge and Radiated Spurious Emissions	30MHz – 1GHz	Confidence level of approximately 95% (in the case where distributions are normal), with a coverage factor of 2 (for EUTs < 0.5m X 0.5m X 0.5m)	+5.6dB/-4.5dB
Band Edge and Radiated Spurious Emissions	1GHz – 40GHz	Confidence level of approximately 95% (in the case where distributions are normal), with a coverage factor of 2 (for EUTs < 0.5m X 0.5m X 0.5m)	+4.3dB/-4.1dB

## 10 Measurements, Examination and Derived Results

### 10.1 Antenna Requirement

Spec	Requirement	Applicable
§15.203	<p>An intentional radiator shall be designed to ensure that no antenna other than that furnished by the responsible party shall be used with the device.</p> <p>Antenna requirement must meet at least one of the following:</p> <p>a) Antenna must be permanently attached to the device.            b) Antenna must use a unique type of connector to attach to the device.            c) Device must be professionally installed. Installer shall be responsible for ensuring that the correct antenna is employed with the device.</p>	<input checked="" type="checkbox"/>
Remark	The RFID antenna is integral to the PCB board permanently to the device which meets the requirement (See Internal Photographs submitted as another Exhibit).	
Result	<input checked="" type="checkbox"/> PASS <input type="checkbox"/> FAIL	

## 10.2 Conducted Emissions

### Conducted Emission Limit

Frequency ranges (MHz)	Limit (dBuV)	
	QP	Average
0.15 ~ 0.5	66 – 56	56 – 46
0.5 ~ 5	56	46
5 ~ 30	60	50

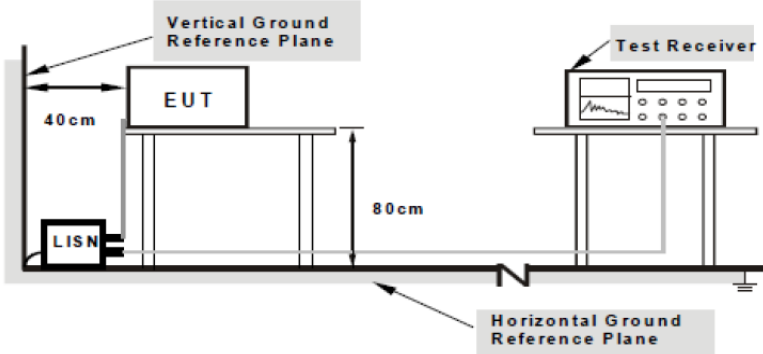
Spec	Item	Requirement	Applicable
47CFR§15.207, RSS210(A8.1)	a)	For Low-power radio-frequency devices that is designed to be connected to the public utility (AC) power line, the radio frequency voltage that is conducted back onto the AC power line on any frequency or frequencies, within the band 150 kHz to 30 MHz, shall not exceed the limits in the following table, as measured using a 50 [mu]H/50 ohms line impedance stabilization network (LISN). The lower limit applies at the boundary between the frequency ranges.	<input checked="" type="checkbox"/>
Test Setup	 <p>Note: 1.Support units were connected to second LISN. 2.Both of LISNs (AMN) are 80cm from EUT and at least 80cm from other units and other metal planes support units.</p>		
Procedure	<ul style="list-style-type: none"> <li>- The EUT and supporting equipment were set up in accordance with the requirements of the standard on top of a 1.5m x 1m x 0.8m high, non-metallic table, as shown in Annex B.</li> <li>- The power supply for the EUT was fed through a 50Ω/50μH EUT LISN, connected to filtered mains.</li> <li>- The RF OUT of the EUT LISN was connected to the EMI test receiver via a low-loss coaxial cable.</li> <li>- All other supporting equipment were powered separately from another main supply.</li> </ul>		
Remark	None		
Result	<input checked="" type="checkbox"/> Pass <input type="checkbox"/> Fail		

Test Data     Yes                       N/A

Test Plot     Yes (See below)             N/A



### 10.2.1 Conducted Emission Test Results (AC Line Test Result)

Environmental Conditions:	Temp (°C):	21.5	Result	Pass
	Humidity (%)	37		
	Atmospheric (mPa):	1028		
Mains Power:	120 VAC/ 60Hz/ Neutral Line			
Tested by:	David Zhang			
Test Date:	07/17/2014			
Remarks:	None			

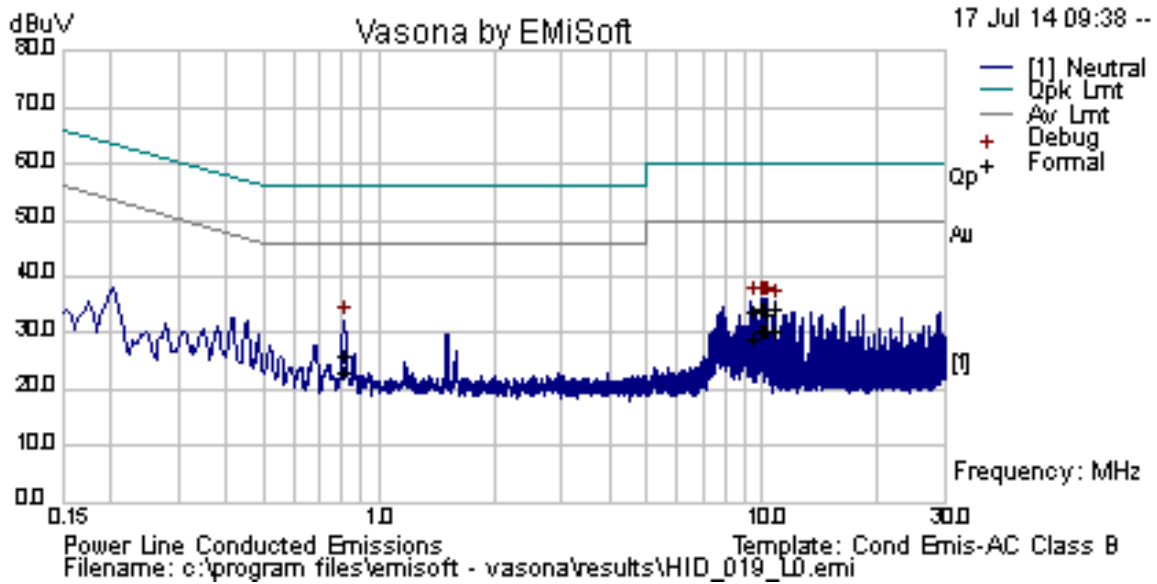

Frequency MHz	Raw dBuV	Cable Loss	Factors dB	Level dBuV	Measurement Type	Line	Limit dBuV	Margin dB	Pass /Fail
0.81	15.00	10.01	0.76	25.78	Quasi Peak	Neutral	56.00	-30.22	Pass
10.24	22.03	10.05	1.44	33.52	Quasi Peak	Neutral	60.00	-26.48	Pass
10.06	22.70	10.05	1.43	34.17	Quasi Peak	Neutral	60.00	-25.83	Pass
9.94	22.87	10.05	1.42	34.33	Quasi Peak	Neutral	60.00	-25.67	Pass
9.39	22.21	10.05	1.37	33.63	Quasi Peak	Neutral	60.00	-26.37	Pass
10.79	22.68	10.05	1.49	34.22	Quasi Peak	Neutral	60.00	-25.78	Pass
0.81	12.24	10.01	0.76	23.02	Average	Neutral	46.00	-22.98	Pass
10.24	18.93	10.05	1.44	30.42	Average	Neutral	50.00	-19.58	Pass
10.06	18.93	10.05	1.43	30.40	Average	Neutral	50.00	-19.60	Pass
9.94	19.01	10.05	1.42	30.48	Average	Neutral	50.00	-19.52	Pass
9.39	17.77	10.05	1.37	29.19	Average	Neutral	50.00	-20.81	Pass
10.79	18.85	10.05	1.49	30.39	Average	Neutral	50.00	-19.61	Pass

Environmental Conditions:	Temp (°C):	21.5	Result	Pass
	Humidity (%)	37		
	Atmospheric (mPa):	1028		
Mains Power:	120 VAC/ 60Hz/ Phase Line			
Tested by:	David Zhang			
Test Date:	07/17/2014			
Remarks:	None			

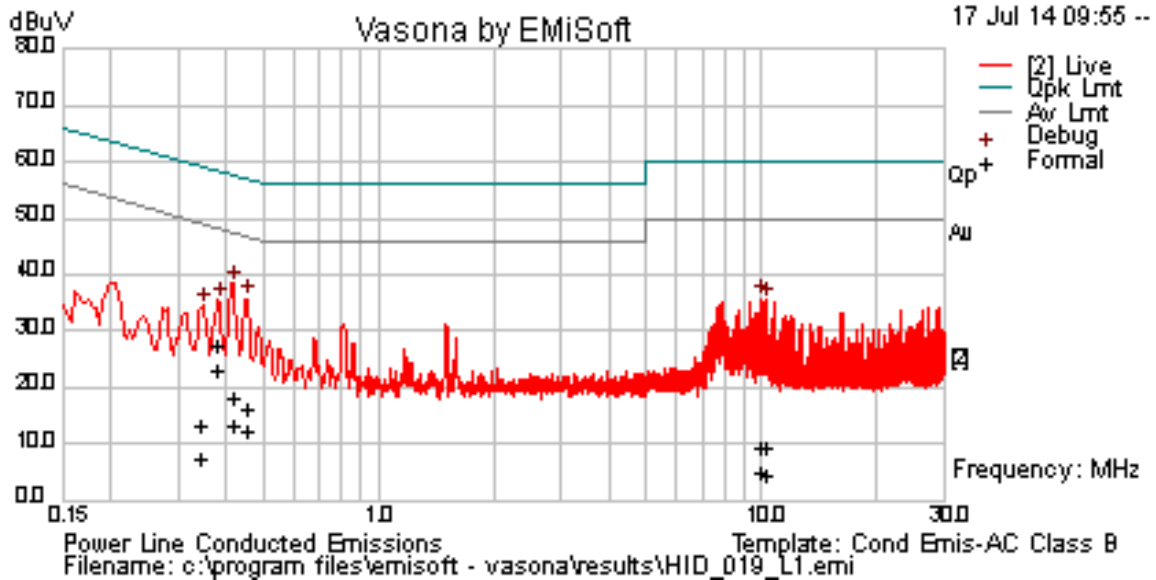

Frequency MHz	Raw dBuV	Cable Loss	Factors dB	Level dBuV	Measurement Type	Line	Limit dBuV	Margin dB	Pass /Fail
0.42	7.50	10.01	0.73	18.24	Quasi Peak	Live	57.52	-39.28	Pass
0.45	5.56	10.01	0.73	16.30	Quasi Peak	Live	56.85	-40.55	Pass
0.38	16.65	10.01	0.72	27.38	Quasi Peak	Live	58.36	-30.98	Pass
9.94	-1.90	10.05	1.42	9.57	Quasi Peak	Live	60.00	-50.43	Pass
0.34	2.56	10.01	0.72	13.29	Quasi Peak	Live	59.10	-45.81	Pass
10.25	-2.31	10.05	1.44	9.18	Quasi Peak	Live	60.00	-50.82	Pass
0.42	2.68	10.01	0.73	13.42	Average	Live	47.52	-34.11	Pass
0.45	1.41	10.01	0.73	12.15	Average	Live	46.85	-34.70	Pass
0.38	12.58	10.01	0.72	23.31	Average	Live	48.36	-25.05	Pass
9.94	-6.73	10.05	1.42	4.74	Average	Live	50.00	-45.26	Pass
0.34	-3.41	10.01	0.72	7.31	Average	Live	49.10	-41.78	Pass
10.25	-7.18	10.05	1.44	4.31	Average	Live	50.00	-45.69	Pass

### 10.3 20dB Bandwidth

**Requirement(s):**

Spec	Item	Requirement	Applicable
47CFR§15.247(a), RSS210(A8.1)(b)	a)	Frequency hopping systems shall have hopping channel carrier frequencies separated by a minimum of 25kHz or the 20dB bandwidth of the hopping channel, whichever is greater. However, frequency hopping systems operated in 2400-2483.5MHz with output power not greater than 125mW, the intervals of hopping channel carrier frequencies shall not be less than 25kHz or two thirds of the 20dB bandwidth of the hopping channel, whichever is greater.	<input type="checkbox"/>
47CFR§15.247(a), RSS210(A8.1)(e)	b)	Frequency hopping systems operating in the 5725-5850MHz band shall use at least 75 hopping frequencies. The maximum 20dB bandwidth of the hopping channel is 1MHz.	<input type="checkbox"/>
Test Setup			
Test Procedure	<p><u>20dB Emission bandwidth measurement procedure</u></p> <ul style="list-style-type: none"> <li>- Set RBW <math>\geq</math> 1% 20dB Bandwidth</li> <li>- Set the video bandwidth (VBW) <math>\geq</math> RBW.</li> <li>- Detector = Peak.</li> <li>- Trace mode = max hold.</li> <li>- Sweep = auto couple.</li> <li>- Allow the trace to stabilize.</li> <li>- Measure the maximum width of the emission that is constrained by the frequencies associated with the two outermost amplitude points (upper and lower frequencies) that are attenuated by 6 dB relative to the maximum level measured in the fundamental emission.</li> </ul>		
Test Date	07/16/2013	Environmental condition	Temperature 22°C Relative Humidity 47% Atmospheric Pressure 1019mbar
Remark	The 20 dB test result and the 2/3 of 20 dB data calculation are for channel separation measurement reference only. There isn't limit for 20 dB bandwidth for this product.		
Result	<input checked="" type="checkbox"/> Pass <input type="checkbox"/> Fail		

**Equipment Setting**

TEST	RBW	VBW	SPAN	Detector	SWEEP	Trace	NOTES
20dB Bandwidth	$\geq$ 1% 20dB bandwidth	$\geq$ RBW	~2 – 3 times 20dBbandwidth	PK	Auto	Maxhold	-

**Test Data**     Yes                                       N/A

**Test Plot**     Yes (See below)                                       N/A

20dB Bandwidth measurement result

Type	Freq (MHz)	Test mode	CH	20dB Bandwidth (KHz)	2/3 20dB Bandwidth (KHz)	Pass/Fail
20dB OBW	902.750	Cont-TX	Low	119.291	79.527	N/A
20dB OBW	915.250	Cont-TX	Mid	111.195	74.130	N/A
20dB OBW	927.250	Cont-TX	High	118.157	78.771	N/A

Test Plots

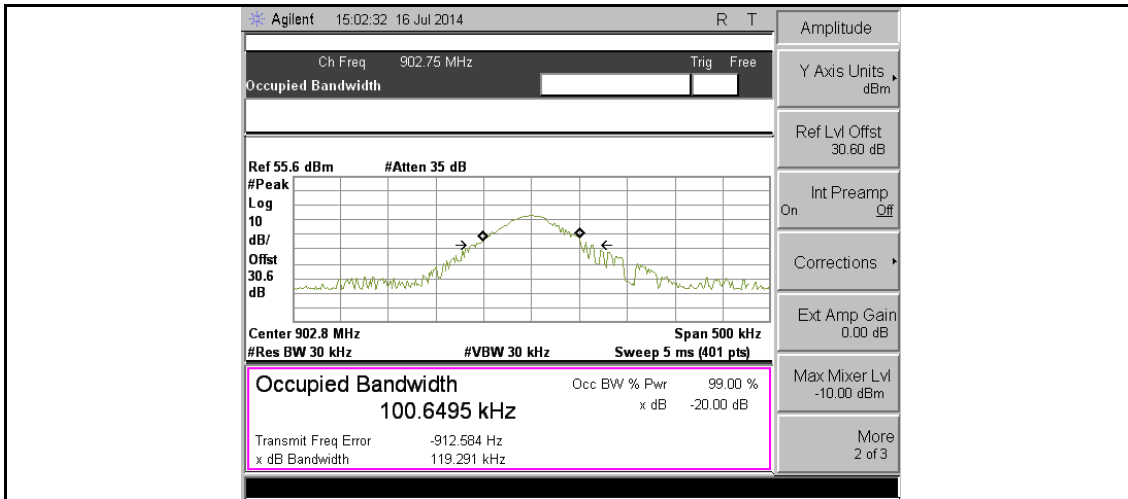

20dB Low CH

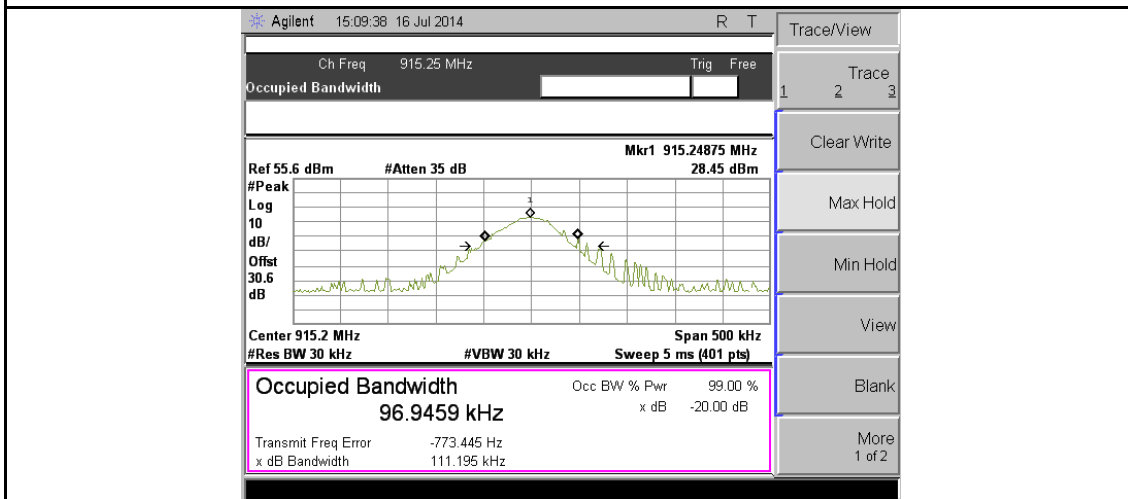

20dB Mid CH

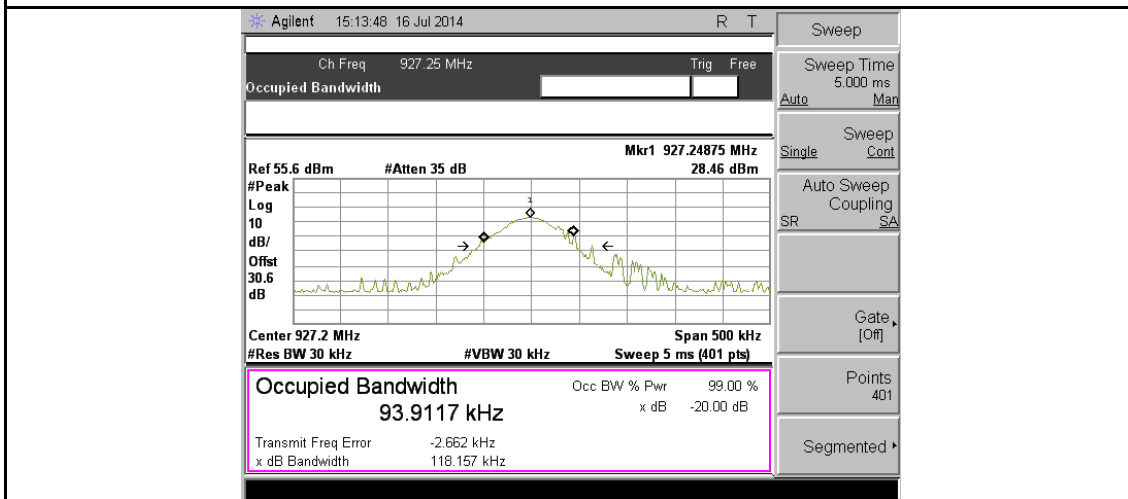

20dB High CH

### 10.4 99% Occupied Bandwidth

**Requirement(s):**

Spec	Requirement	Applicable									
RSS Gen 4.6.1	The transmitter shall be operated at its maximum carrier power measured under normal test conditions. The span of the analyzer shall be set to capture all products of the modulation process, including the emission skirts. The resolution bandwidth shall be set to as close to 1% of the selected span as is possible without being below 1%. The video bandwidth shall be set to 3 times the resolution bandwidth. Video averaging is not permitted. Where practical, a sampling detector shall be used given that a peak or peak hold may produce a wider bandwidth than actual. The trace data points are recovered and directly summed in linear terms. The recovered amplitude data points, beginning at the lowest frequency, are placed in a running sum until 0.5% of the total is reached and that frequency recorded. The process is repeated for the highest frequency data points. This frequency is recorded. The span between the two recorded frequencies is the occupied bandwidth	<input checked="" type="checkbox"/>									
Test Setup											
Procedure	<ol style="list-style-type: none"> <li>EUT was set for low , mid, high channel with modulated mode and highest RF output power.</li> <li>The spectrum analyzer was connected to the antenna terminal.</li> </ol>										
Test Date	07/16/2013	<table border="0"> <tr> <td>Environmental condition</td> <td>Temperature</td> <td>22°C</td> </tr> <tr> <td></td> <td>Relative Humidity</td> <td>47%</td> </tr> <tr> <td></td> <td>Atmospheric Pressure</td> <td>1019mbar</td> </tr> </table>	Environmental condition	Temperature	22°C		Relative Humidity	47%		Atmospheric Pressure	1019mbar
Environmental condition	Temperature	22°C									
	Relative Humidity	47%									
	Atmospheric Pressure	1019mbar									
Remark	-										
Result	<input checked="" type="checkbox"/> Pass <input type="checkbox"/> Fail										

**Equipment Setting**

TEST	RBW	VBW	SPAN	Detector	SWEEP	Trace	NOTES
99% Bandwidth	Close to and greater than 1% of SPAN	3xRBW	≥ EBW	PK	Auto	Maxhold	-

**Test Data**     Yes (See below)       N/A

Channel	Channel Frequency (MHz)	99% Occupied Bandwidth (KHz)
Low	902.750	63.317
Mid	915.250	69.840
High	927.250	61.083

**Test Plot**     Yes (See below)       N/A

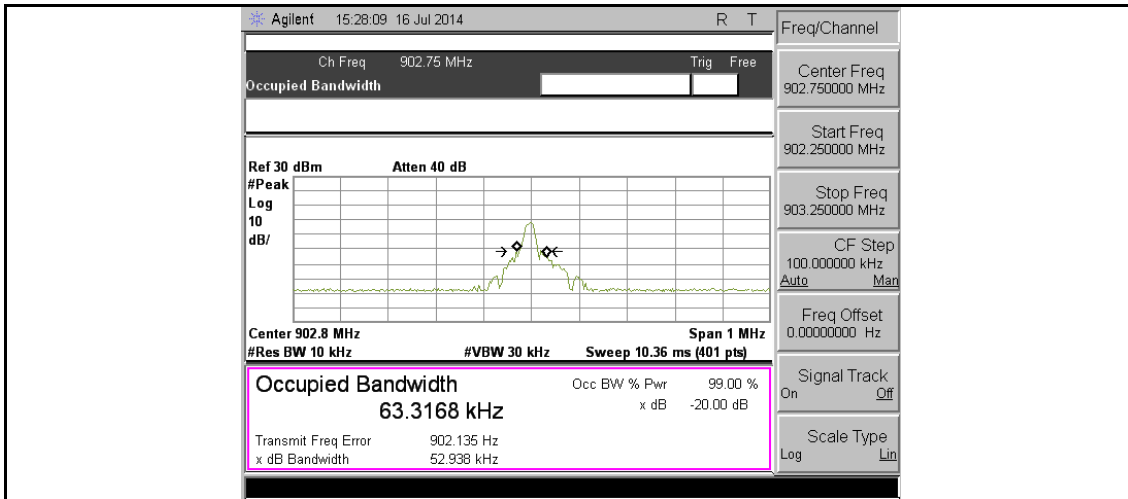

**99% BW Low CH**

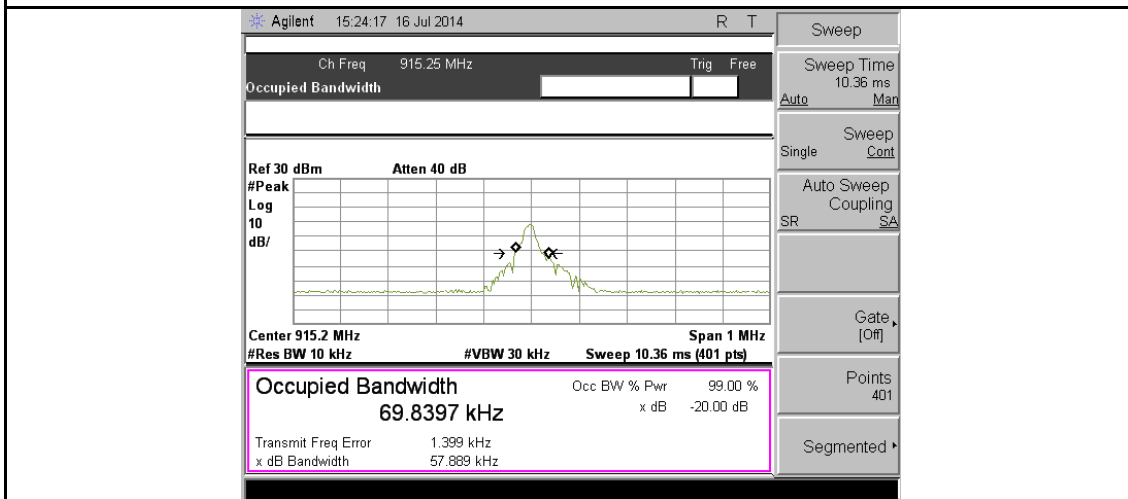

**99% BW Mid CH**

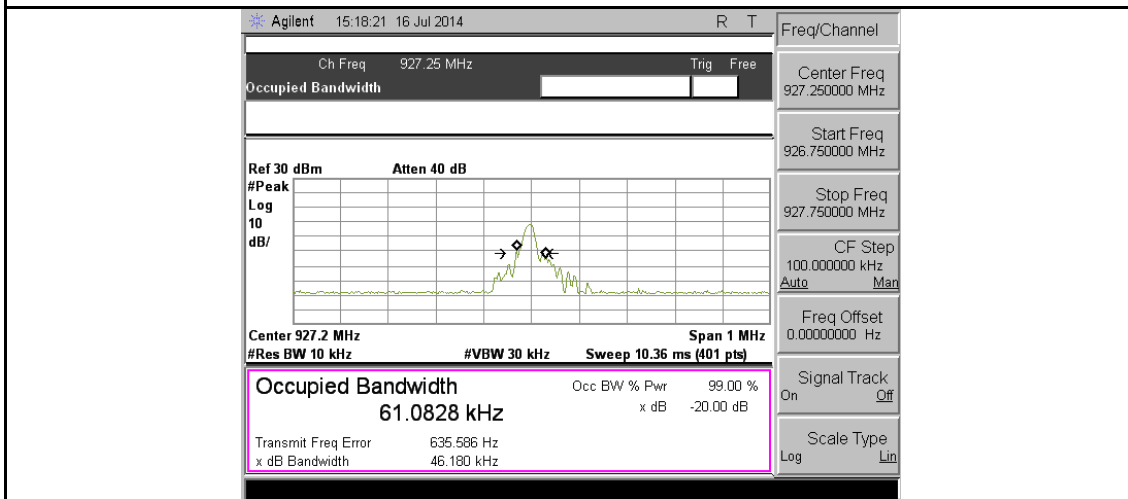

**99% BW High CH**



## 10.5 Number of Hopping Channel

### Requirement(s):

Spec	Item	Requirement	Applicable
47CFR§15.247(a), RSS210(A8.1)	a)	For frequency hopping systems operating in the 902–928 MHz band: if the 20 dB bandwidth of the hopping channel is less than 250 kHz, the system shall use at least 50 hopping frequencies and the average time of occupancy on any frequency shall not be greater than 0.4 seconds within a 20 second period; if the 20 dB bandwidth of the hopping channel is 250 kHz or greater, the system shall use at least 25 hopping frequencies and the average time of occupancy on any frequency shall not be greater than 0.4 seconds within a 10 second period. The maximum allowed 20 dB bandwidth of the hopping channel is 500 kHz	<input checked="" type="checkbox"/>
Test Setup			
Test Procedure	<u>Number of hopping frequencies procedure</u> <ul style="list-style-type: none"> <li>- The EUT must have its hopping function enabled</li> <li>- Span = the frequency band of operation.</li> <li>- Resolution (or IF) Bandwidth (RBW) &gt;= 1% of the span.</li> <li>- Video (or Average) Bandwidth (VBW) &gt;= RBW.</li> <li>- Detector = peak.</li> <li>- Sweep time = auto couple.</li> <li>- Trace mode = max hold.</li> <li>- Allow trace to fully stabilize.</li> <li>- Save the plot</li> </ul>		
Test Date	07/16/2013	Environmental condition	Temperature 22°C Relative Humidity 47% Atmospheric Pressure 1019mbar
Remark	NONE		
Result	<input checked="" type="checkbox"/> Pass <input type="checkbox"/> Fail		

### Equipment Setting

TEST	RBW	VBW	SPAN	Detector	SWEEP	Trace	NOTES
Hopping Channel Number	≥1% Span	≥ RBW	-	PK	Auto	Maxhold	-

Test Data     Yes                       N/A

Test Channel	Channel Number
All CH Hopping	50

Test Plot     Yes (See below)                       N/A

Test Plots

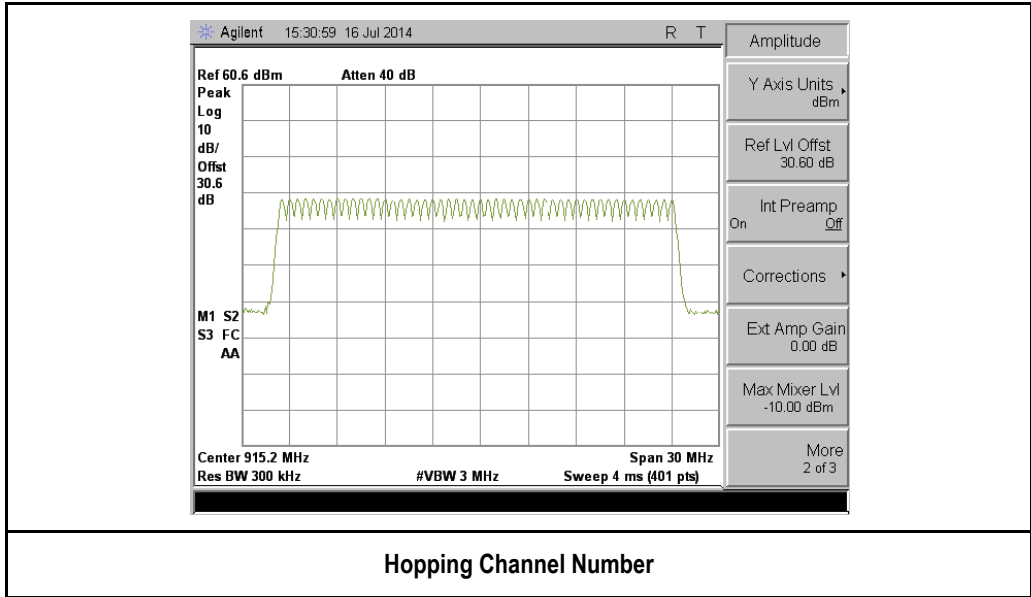

## 10.6 Peak Output Power

### Requirement(s):

Spec	Item	Requirement	Applicable
47CFR§15.247, RSS210(A8.1)	a)	For frequency hopping systems in the 2400-2483.5MHz band employing at least 75 hopping channels, and all frequency hopping systems in the 5725-5850MHz band: below 1 Watt (inclusive).	<input type="checkbox"/>
	b)	For all other frequency hopping systems in the 902-928 MHz band: 1 Watt. The power is converted from watt to dBm, therefore, 1 watt = 30 dBm.	<input checked="" type="checkbox"/>
	c)	frequency hopping systems operated in 2400-2483.5MHz with output power not greater than 125mW, the intervals of hopping channel carrier frequencies shall not be less than 25kHz or two thirds of the 20dB bandwidth of the hopping channel, whichever is greater.	<input type="checkbox"/>
Test Setup			
Test Procedure	<p><u>Maximum output power measurement procedure</u></p> <ul style="list-style-type: none"> <li>- Span = approximately 5 times the 20 dB bandwidth, centered on a hopping channel.</li> <li>- RBW &gt; 1% of the 20 dB bandwidth of the emission being measured;</li> <li>- VBW &gt;= RBW.</li> <li>- Detector = peak.</li> <li>- Sweep time = auto couple.</li> <li>- Trace mode = max hold.</li> <li>- Allow trace to fully stabilize.</li> <li>- Use the marker-to-peak function to set the marker to the peak of the emission. The indicated level is the peak output power.</li> </ul>		
Test Date	07/16/2013	Environmental condition	Temperature 22°C Relative Humidity 47% Atmospheric Pressure 1019mbar
Remark	NONE		
Result	<input checked="" type="checkbox"/> Pass <input type="checkbox"/> Fail		

### Equipment Setting

TEST	RBW	VBW	SPAN	Detector	SWEEP	Trace	NOTES
PK output power	≥1% 20dB bandwidth	≥ RBW	~ 5 times 20dB bandwidth	Peak	Auto	Maxhold	Including Cable loss and Attenuation

Test Data  Yes  N/A

Test Plot  Yes (See below)  N/A

Output Power measurement result

Type	Freq (MHz)	Test mode	CH	Conducted Power (dBm)	Limit (dBm)	Result
Output power	902.75	Cont-TX	Low	28.81	30	Pass
Output power	915.25	Cont-TX	Mid	28.46	30	Pass
Output power	927.25	Cont-TX	High	28.52	30	Pass

Test Plots

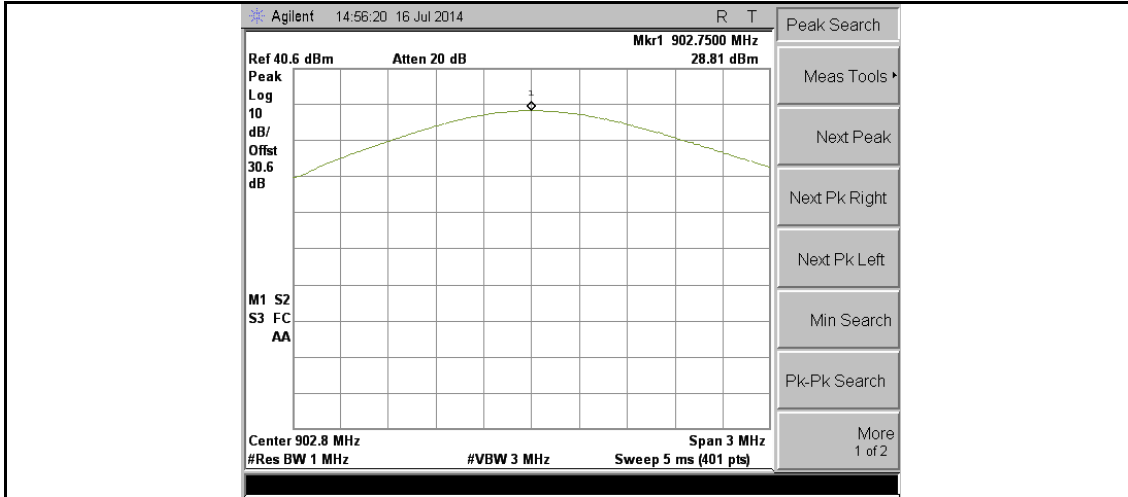

FCC-15.247-PWR-902.75M

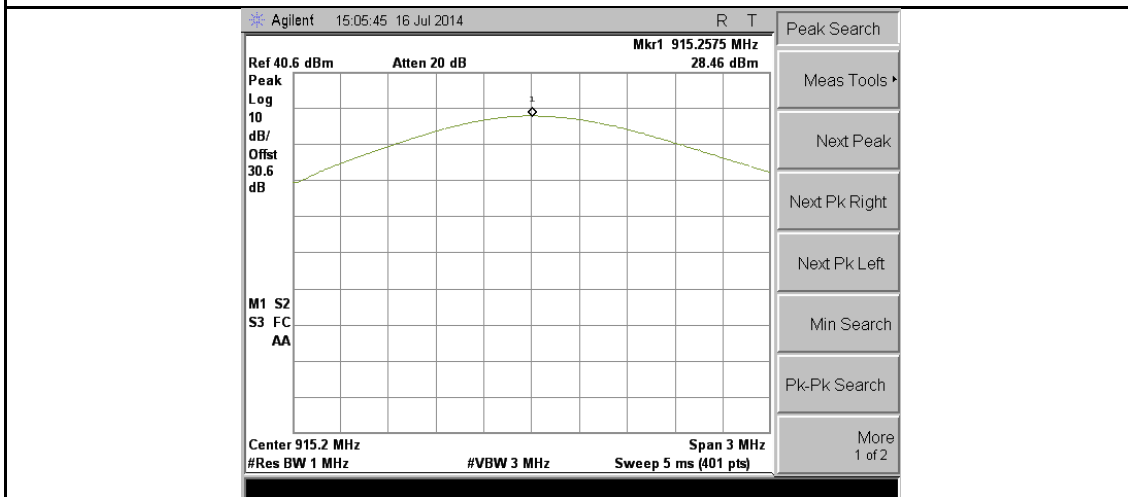

FCC-15.247-PWR-915.25M

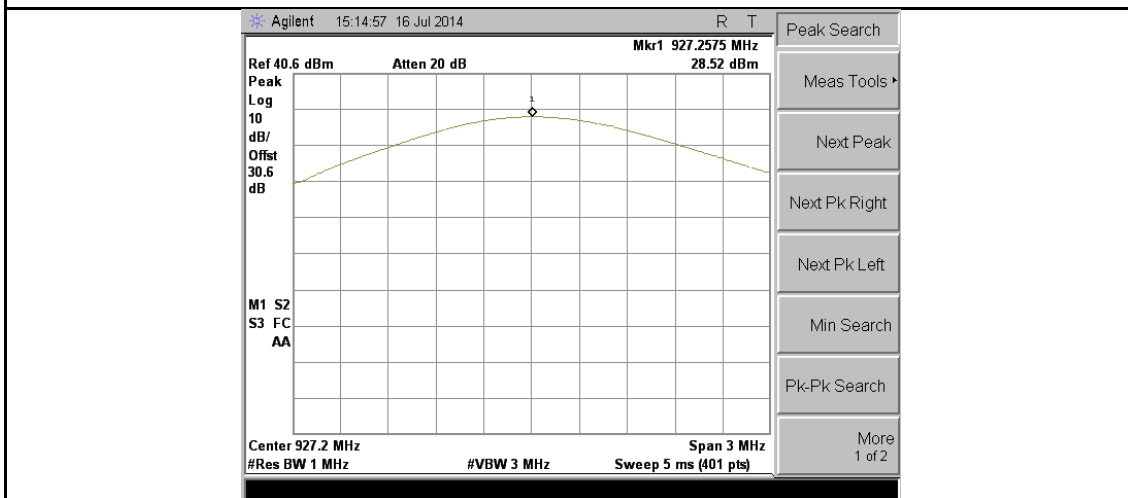

FCC-15.247-PWR-927.25M

## 10.7 Channel Separation

### Requirement(s):

Spec	Item	Requirement	Applicable
47CFR§15.247, RSS210(A8.1)	a)	Frequency hopping systems shall have hopping channel carrier frequencies separated by a minimum of 25 kHz or the 20 dB bandwidth of the hopping channel, whichever is greater.	<input checked="" type="checkbox"/>
Test Setup			
Test Procedure	DA 00-705 Measurement Guidelines for Frequency Hopping Spread Spectrum Systems  <u>Channel Separation procedure</u> <ul style="list-style-type: none"> <li>- The EUT must have its hopping function enabled.</li> <li>- Span = wide enough to capture the peaks of two adjacent channels</li> <li>- Resolution (or IF) Bandwidth (RBW) &gt;= 1% of the span</li> <li>- Video (or Average) Bandwidth (VBW) &gt;= RBW.</li> <li>- Detector = Peak.</li> <li>- Trace mode = max hold.</li> <li>- Use the marker-delta function to determine the separation between the peaks of the adjacent channels.</li> </ul>		
Test Date	07/16/2013	Environmental condition	Temperature 22°C Relative Humidity 47% Atmospheric Pressure 1019mbar
Remark	NONE		
Result	<input checked="" type="checkbox"/> Pass <input type="checkbox"/> Fail		

### Equipment Setting

TEST	RBW	VBW	SPAN	Detector	SWEEP	Trace	NOTES
Channel Separation	≥1% Span	≥ RBW	-	PK	Auto	Maxhold	-

Test Data     Yes                       N/A

Test Plot     Yes (See below)               N/A

Measurement result

Type	Freq (MHz)	Test mode	CH	Result (MHz)	20dB Bandwidth (MHz)	Result
Channel Sep	902.750	Con-TX	Low	0.500	0.119	Pass
Channel Sep	915.250	Con-TX	Mid	0.500	0.111	Pass
Channel Sep	927.250	Con-TX	High	0.500	0.118	Pass



Test Plots

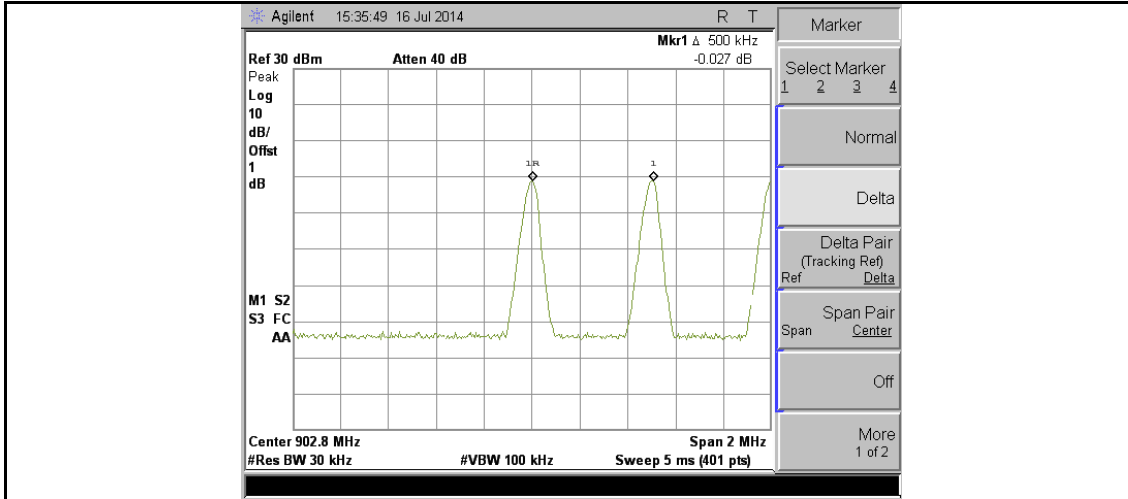

FCC-15.247- Ch Sep-902.75M

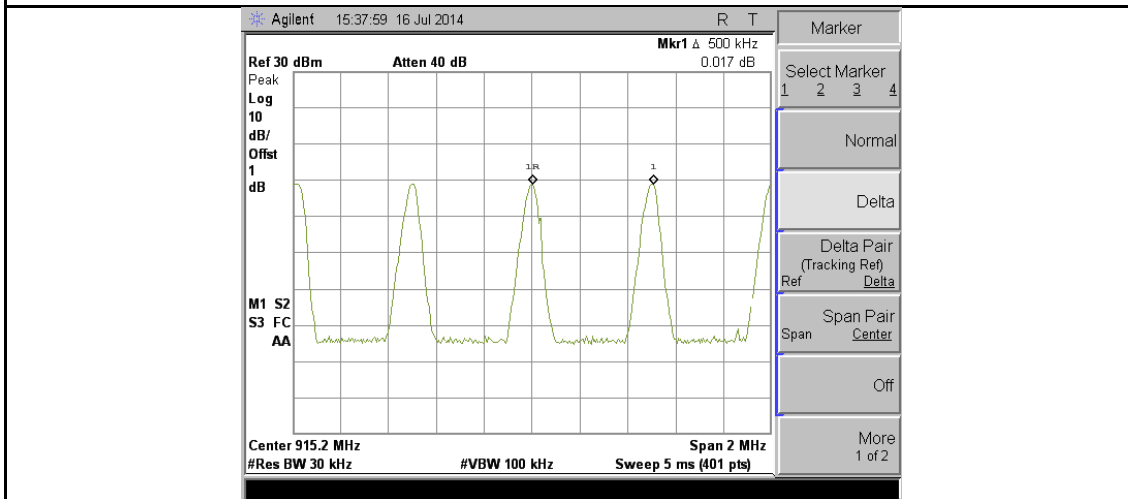

FCC-15.247- Ch Sep-915.25M

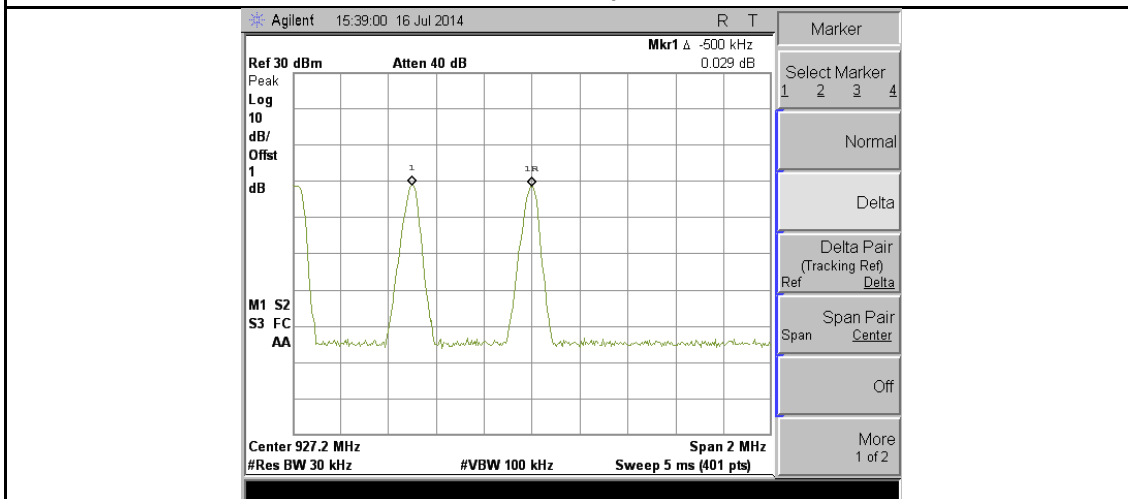

FCC-15.247- Ch Sep-927.25M

## 10.8 Time of Occupancy

### Requirement(s):

Spec	Requirement	Applicable
47CFR§15.247, RSS210(A8.1)	For frequency hopping systems operating in the 902–928 MHz band: if the 20 dB bandwidth of the hopping channel is less than 250 kHz, the system shall use at least 50 hopping frequencies and the average time of occupancy on any frequency shall not be greater than 0.4 seconds within a 20 second period; if the 20 dB bandwidth of the hopping channel is 250 kHz or greater, the system shall use at least 25 hopping frequencies and the average time of occupancy on any frequency shall not be greater than 0.4 seconds within a 10 second period. The maximum allowed 20 dB bandwidth of the hopping channel is 500 kHz	<input checked="" type="checkbox"/>
Test Setup		
Test Procedure	DA 00-705 Measurement Guidelines for Frequency Hopping Spread Spectrum Systems  <u>Channel Separation procedure</u> <ul style="list-style-type: none"> <li>- The EUT must have its hopping function enabled.</li> <li>- Span = zero span</li> <li>- centered on a hopping channel</li> <li>- RBW = 1 MHz; VBW &gt;= RBW</li> <li>- Sweep = as necessary to capture the entire dwell time per hopping channel.</li> <li>- Detector = Peak.</li> <li>- Trace mode = max hold.</li> <li>- If possible, use the marker-delta function to determine the dwell time. If this value varies with different modes of operation (e.g., data rate, modulation format, etc.), repeat this test for each variation.</li> </ul>	
Test Date	07/16/2013	Environmental condition Temperature 22°C Relative Humidity 47% Atmospheric Pressure 1019mbar
Remark	Dwell time = 20 sec / Repetition cycle time * Pulse on time	
Result	<input checked="" type="checkbox"/> Pass <input type="checkbox"/> Fail	

### Equipment Setting

TEST	RBW	VBW	SPAN	Detector	SWEEP	Trace	NOTES
Occupied Time	1MHz	≥ RBW	0Hz	PK	-	Maxhold	-

Test Data     Yes                       N/A

Test Plot     Yes (See below)               N/A

Dwell time measurement result

Type	Freq (MHz)	Test mode	CH	Pulse time (msec)	Cycle period for pulse (msec)	Dwell Time (sec)	Limit (Sec)
Dwell time	902.750	Cont-TX	Low	18.68	5100	0.073	0.4
Dwell time	915.250	Cont-TX	Mid	18.60	5200	0.072	0.4
Dwell time	927.250	Cont-TX	High	16.58	5100	0.065	0.4

Note:

Dwell time = 20 sec / Repetition cycle time \* Pulse on time

**Test Plots**

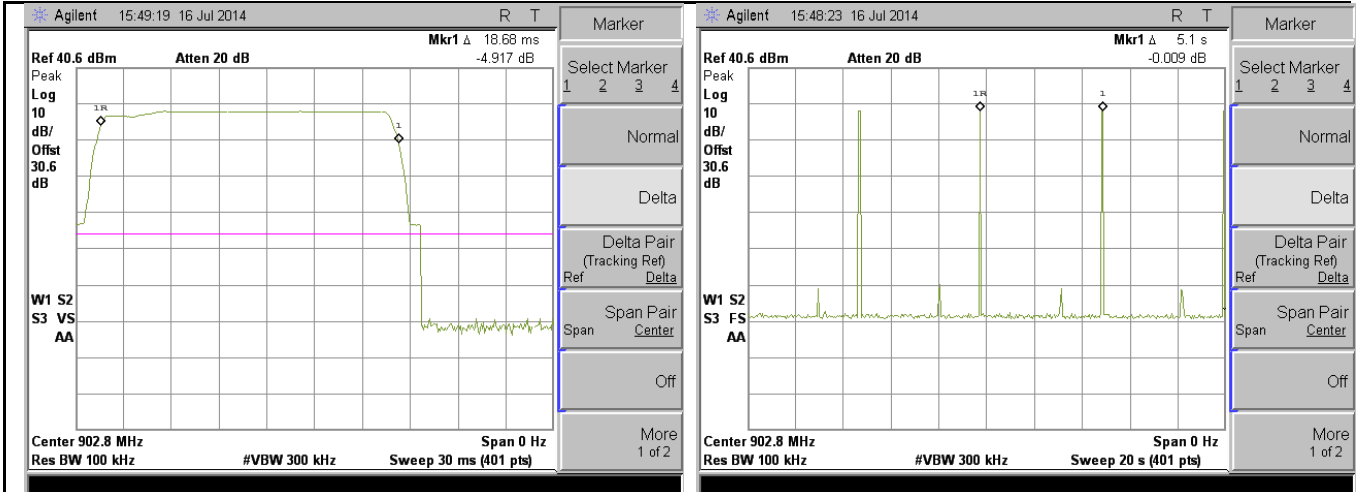

**FCC-15.247-DwT-902.75M**

**FCC-15.247-DwT-Num-904.86M**

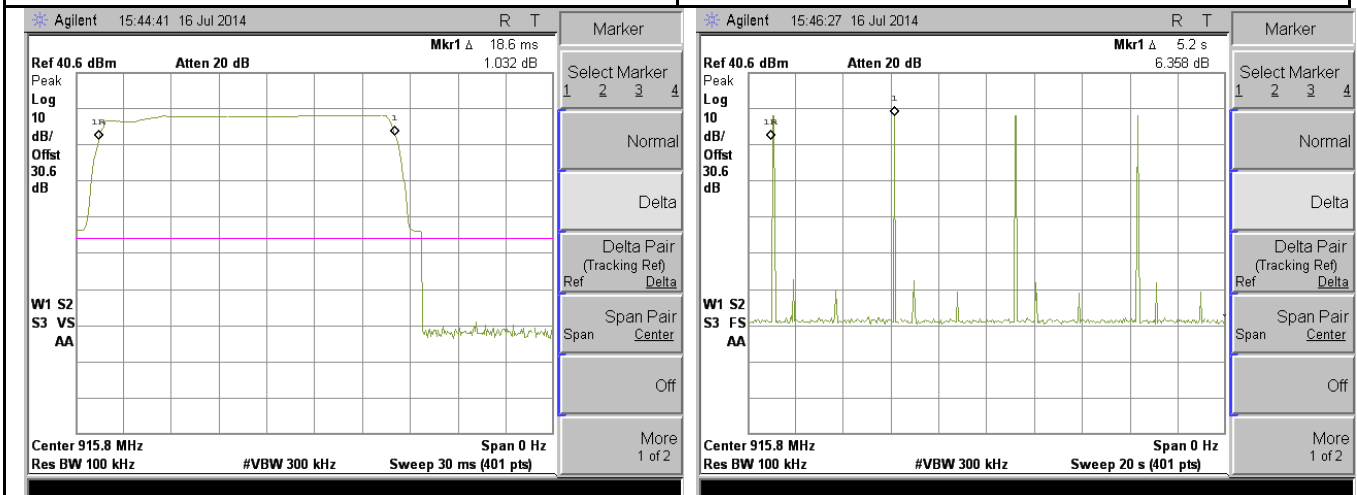

**FCC-15.247-DwT-915.25M**

**FCC-15.247-DwT-Num-915.25M**

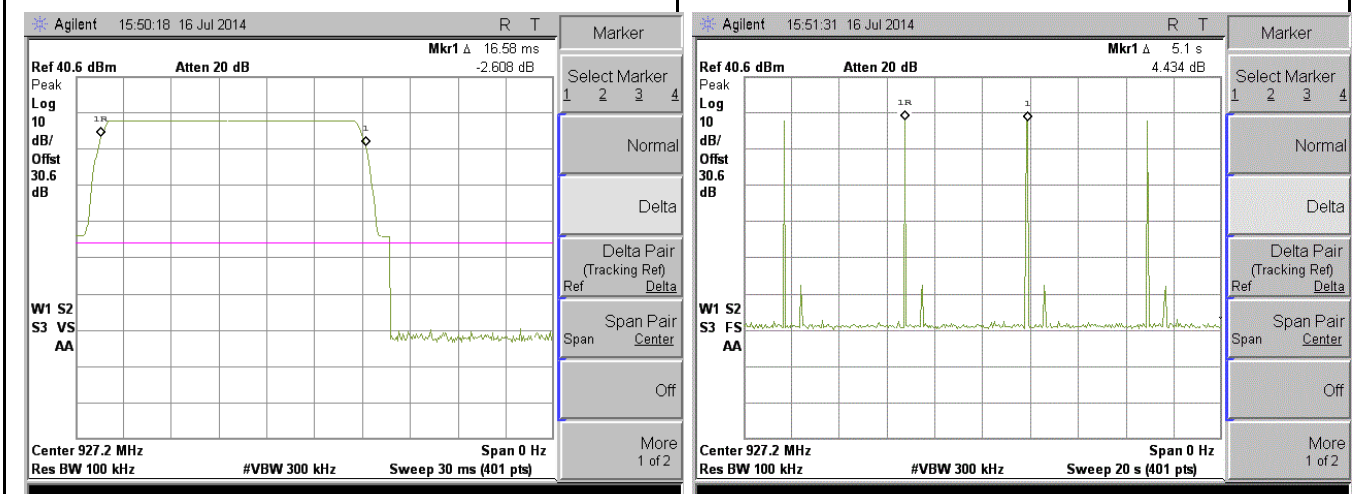

**FCC-15.247-DwT-927.25M**

**FCC-15.247-DwT-Num-927.25M**

### 10.9 100 KHz Bandwidth of Frequency Band Edge

**Requirement(s):**

Spec	Requirement	Applicable									
47 CFR §15.247 (b) RSS-210 (A2.6)	In any 100 kHz bandwidth outside the frequency band in which the spread spectrum intentional radiator is operating, the radio frequency power that is produced by the intentional radiator shall be at least 20 dB below that in the 100 kHz bandwidth within the band that contains the highest level of the desired power, based on either an RF conducted or a radiated measurement. Attenuation below the general limits specified in §15.209(a) is not required	<input checked="" type="checkbox"/>									
Test Setup											
Procedure	<ol style="list-style-type: none"> <li>EUT was set for low , mid, high channel with modulated mode and highest RF output power.</li> <li>The spectrum analyzer was connected to the antenna terminal.</li> <li>RBW=3 KHz, VBW &gt; RBW, Sweep time: auto</li> </ol>										
Test Date	07/16/2014	<table border="1"> <tr> <td>Environmental condition</td> <td>Temperature</td> <td>24°C</td> </tr> <tr> <td></td> <td>Relative Humidity</td> <td>47%</td> </tr> <tr> <td></td> <td>Atmospheric Pressure</td> <td>1019mbar</td> </tr> </table>	Environmental condition	Temperature	24°C		Relative Humidity	47%		Atmospheric Pressure	1019mbar
Environmental condition	Temperature	24°C									
	Relative Humidity	47%									
	Atmospheric Pressure	1019mbar									
Remark	-										
Result	<input checked="" type="checkbox"/> Pass <input type="checkbox"/> Fail										

**Test Data**     Yes (See below)       N/A

Band Edge – Single Channel Cont-TX

Channel	Channel Frequency (MHz)	Measured (dB)	Limit (dB)	Pass/Fail
Low	902.750	56.78	More than 20	Pass
High	927.250	57.76	More than 20	Pass

Band Edge – Hopping mode

Channel	Channel Frequency (MHz)	Measured (dB)	Limit (dB)	Pass/Fail
Low	902.750	56.60	More than 20	Pass
High	927.250	57.76	More than 20	Pass

**Test Plot**     Yes (See below)       N/A

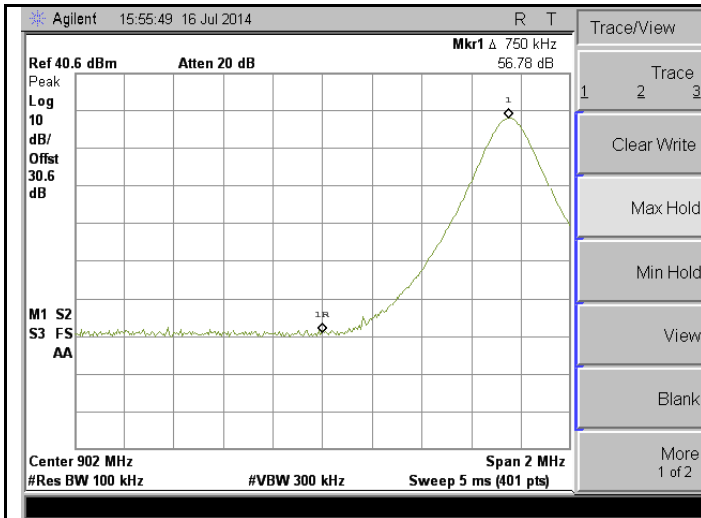

**Band Edge-Low Channel (Single CH Cont-TX)**

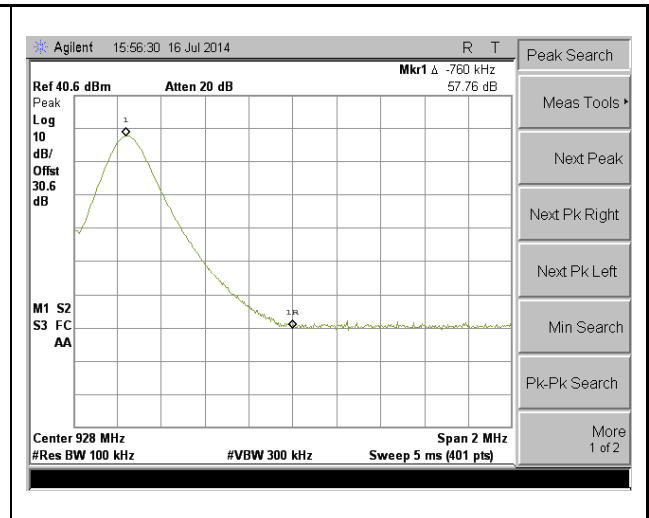

**Band Edge-High Channel (Single CH Cont-TX)**

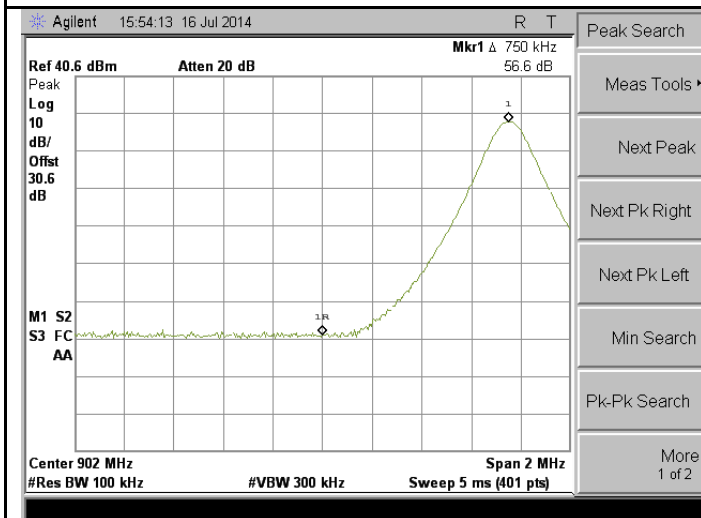

**Band Edge-Low Channel (Hopping mode)**

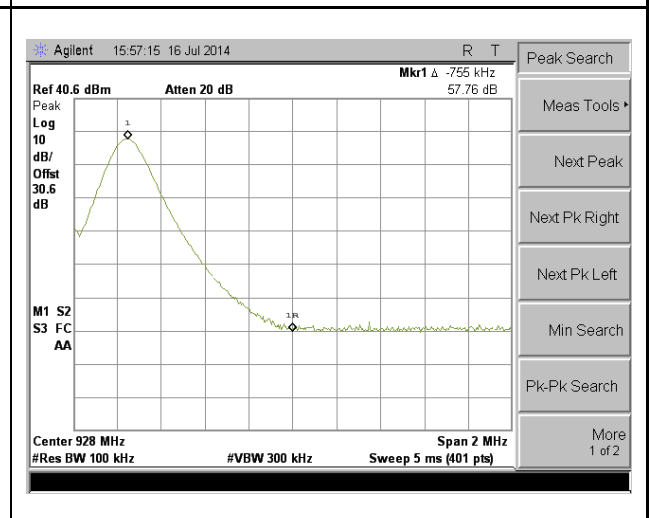

**Band Edge-High Channel (Hopping mode)**

**10.10 Radiated Emissions below 1GHz**

**Requirement(s):**

Spec	Item	Requirement	Applicable										
47CFR§15.247(d), RSS210(A8.5)	a)	Except higher limit as specified elsewhere in other section, the emissions from the low-power radio-frequency devices shall not exceed the field strength levels specified in the following table and the level of any unwanted emissions shall not exceed the level of the fundamental emission. The tighter limit applies at the band edges  <table border="1"> <thead> <tr> <th>Frequency range (MHz)</th> <th>Field Strength (uV/m)</th> </tr> </thead> <tbody> <tr> <td>30 – 88</td> <td>100</td> </tr> <tr> <td>88 – 216</td> <td>150</td> </tr> <tr> <td>216 960</td> <td>200</td> </tr> <tr> <td>Above 960</td> <td>500</td> </tr> </tbody> </table>	Frequency range (MHz)	Field Strength (uV/m)	30 – 88	100	88 – 216	150	216 960	200	Above 960	500	<input checked="" type="checkbox"/>
Frequency range (MHz)	Field Strength (uV/m)												
30 – 88	100												
88 – 216	150												
216 960	200												
Above 960	500												
Test Setup													
Procedure		<ol style="list-style-type: none"> <li>The EUT was switched on and allowed to warm up to its normal operating condition.</li> <li>The test was carried out at the selected frequency points obtained from the EUT characterisation. Maximization of the emissions, was carried out by rotating the EUT, changing the antenna polarization, and adjusting the antenna height in the following manner:               <ol style="list-style-type: none"> <li>Vertical or horizontal polarisation (whichever gave the higher emission level over a full rotation of the EUT) was chosen.</li> <li>The EUT was then rotated to the direction that gave the maximum emission.</li> <li>Finally, the antenna height was adjusted to the height that gave the maximum emission.</li> </ol> </li> <li>A Quasi-peak measurement was then made for that frequency point.</li> <li>Steps 2 and 3 were repeated for the next frequency point, until all selected frequency points were measured.</li> </ol>											
Remark		NONE											
Result		<input checked="" type="checkbox"/> Pass <input type="checkbox"/> Fail											

**Test Data**     Yes (See below)       N/A

**Test Plot**     Yes (See below)       N/A



### Radiated Emission Test Results (Below 1GHz)

Test specification	below 1GHz			Result	Pass
Environmental Conditions:	Temp (°C):	22			
	Humidity (%)	46			
	Atmospheric (mPa):	1008			
Mains Power:	12VDC				
Tested by:	David Zhang				
Test Date:	07/16/2014				
Remarks:	UHF RFID @ 915.25MHz, Cont-TX, measured at 10 m distance Emission at 915MHz is fundamental frequency				

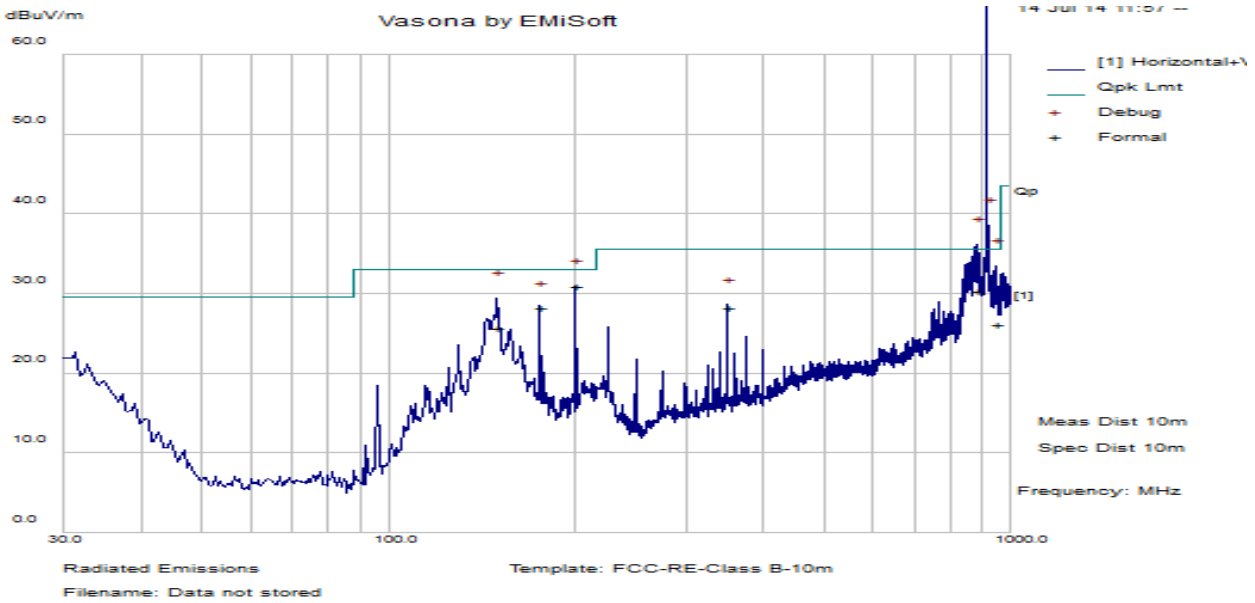

Frequency MHz	Raw dBuV	Cable Loss	AF dB	Level dBuV/m	Measurement Type	Pol	Hgt cm	Azt Deg	Limit dBuV/m	Margin dB	Pass /Fail
879.85	42.95	4.97	-17.64	30.28	Quasi Max	V	181	336	35.50	-5.22	Pass
199.99	56.34	2.50	-27.93	30.91	Quasi Max	H	309	91	33.00	-2.09	Pass
943.19	38.42	5.08	-17.40	26.10	Quasi Max	H	282	352	35.50	-9.40	Pass
149.12	51.44	2.22	-27.89	25.76	Quasi Max	V	111	258	33.00	-7.24	Pass
174.99	54.96	2.37	-29.07	28.27	Quasi Max	V	130	147	33.00	-4.73	Pass
349.98	50.74	3.18	-25.67	28.25	Quasi Max	H	225	125	35.50	-7.25	Pass

### 10.11 Radiated Spurious Emissions above 1GHz

**Requirement(s):**

Spec	Item	Requirement	Applicable
47CFR§15.247(d), RSS210(A8.5)	a)	For non-restricted band, In any 100 kHz bandwidth outside the frequency band in which the spread spectrum or digitally modulated intentional radiator is operating, the radio frequency power that is produced by the intentional radiator shall be at least 20 dB or 30dB below that in the 100 kHz bandwidth within the band that contains the highest level of the desired power, determined by the measurement method on output power to be used. Attenuation below the general limits specified in § 15.209(a) is not required  <input checked="" type="checkbox"/> 20 dB down <input type="checkbox"/> 30 dB down	<input checked="" type="checkbox"/>
	b)	or restricted band, emission must also comply with the radiated emission limits specified in 2.8	<input checked="" type="checkbox"/>

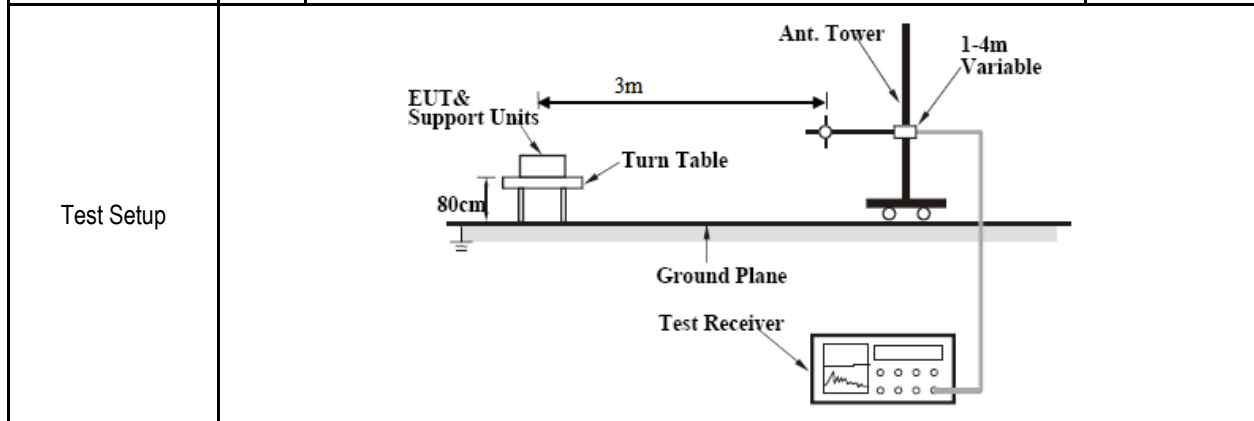

**Procedure**

- The EUT was switched on and allowed to warm up to its normal operating condition.
- The test was carried out at the selected frequency points obtained from the EUT characterisation. Maximization of the emissions, was carried out by rotating the EUT, changing the antenna polarization, and adjusting the antenna height in the following manner:
  - Vertical or horizontal polarisation (whichever gave the higher emission level over a full rotation of the EUT) was chosen.
  - The EUT was then rotated to the direction that gave the maximum emission.
  - Finally, the antenna height was adjusted to the height that gave the maximum emission.
- An average measurement was then made for that frequency point.
- Steps 2 and 3 were repeated for the next frequency point, until all selected frequency points were measured.

Test Date	07/16/2014	Environmental condition	Temperature 22°C Relative Humidity 46% Atmospheric Pressure 1008mbar
Remark	None		
Result	<input checked="" type="checkbox"/> Pass <input type="checkbox"/> Fail		

TEST	RBW	VBW	SPAN	Detector	SWEEP	Trace	NOTES
Radiated Spurious Emission	1MHz	3MHz	1GHz - 10 GHz	Peak	Auto	Max hold	PK meas
Radiated Spurious Emission	1MHz	10Hz	1GHz - 10 GHz	Peak	Auto	Max hold	Ave meas

**Test Data**     Yes (See below)     N/A

**Test Plot**     Yes (See below)     N/A

## Radiated Emission Test Results (Above 1GHz)

### Above 1GHz-10GHz- Mode2: RFID Low (902.75MHz)

Frequency MHz	Raw dBuV	Cable Loss	AF dB	Level dBuV/m	Measurement Type	Pol	Hgt cm	Azt Deg	Limit dBuV/m	Margin dB	Pass /Fail
4949.75	43.13	10.25	3.15	56.53	Peak Max	H	391	220	74.00	-17.47	Pass
2470.35	41.89	7.13	-6.69	42.33	Peak Max	V	154	334	74.00	-31.67	Pass
1805.54	49.45	6.21	-10.50	45.17	Peak Max	V	241	346	74.00	-16.47	Pass
4949.75	29.66	10.25	3.15	43.06	Average Max	H	391	220	54.00	-10.94	Pass
2470.35	28.79	7.13	-6.69	29.23	Average Max	V	154	334	54.00	-15.47	Pass
1805.54	33.56	6.21	-10.50	29.28	Average Max	V	241	346	54.00	-24.72	Pass

### Above 1GHz-10GHz- Mode2: RFID Low (915.25MHz)

Frequency MHz	Raw dBuV	Cable Loss	AF dB	Level dBuV/m	Measurement Type	Pol	Hgt cm	Azt Deg	Limit dBuV/m	Margin dB	Pass /Fail
4589.03	41.11	9.65	2.52	53.28	Peak Max	H	113	132	74.00	-20.72	Pass
5799.94	47.28	9.93	2.63	59.84	Peak Max	H	120	179	74.00	-14.16	Pass
1828.79	43.87	6.23	-10.37	39.73	Peak Max	V	298	58	74.00	-34.27	Pass
4589.03	28.26	9.65	2.52	40.44	Average Max	H	113	132	54.00	-15.47	Pass
5799.94	31.37	9.93	2.63	43.93	Average Max	H	120	179	54.00	-10.07	Pass
1828.79	29.84	6.23	-10.37	25.69	Average Max	V	298	58	54.00	-14.47	Pass

### Above 1GHz-10GHz- Mode2: RFID Low (927.25MHz)

Frequency MHz	Raw dBuV	Cable Loss	AF dB	Level dBuV/m	Measurement Type	Pol	Hgt cm	Azt Deg	Limit dBuV/m	Margin dB	Pass /Fail
4938.64	43.38	10.23	3.13	56.74	Peak Max	H	298	169	74.00	-17.26	Pass
3967.64	40.79	9.27	1.36	51.41	Peak Max	V	169	131	74.00	-16.47	Pass
1854.50	46.09	6.24	-10.24	42.10	Peak Max	V	167	197	74.00	-31.90	Pass
4938.64	29.50	10.23	3.13	42.86	Average Max	H	298	169	54.00	-15.47	Pass
3967.64	28.00	9.27	1.36	38.63	Average Max	V	169	131	54.00	-15.37	Pass
1854.50	32.82	6.24	-10.24	28.82	Average Max	V	167	197	54.00	-14.47	Pass

## Annex A. TEST INSTRUMENT















Instrument	Model	Manufacturer	Serial #	Cal Due	In use
<b><u>Conducted Emission</u></b>					
EMI Receiver	ESHS10	Rohde & Schwarz	830223/0009	2015.04.04	<input checked="" type="checkbox"/>
EMI Analyser	FSIQ7	Rohde & Schwarz	825555/013	2015.04.04	<input checked="" type="checkbox"/>
LISN	ESH2-Z5	Rohde & Schwarz	861741/013	2014.11.13	<input checked="" type="checkbox"/>
LISN	MN2050B	CHASE	1018	2014.07.24	<input checked="" type="checkbox"/>
TLISN	ISN T800	TESEQ	30814	2015.01.23	<input checked="" type="checkbox"/>
<b><u>Radiated Emission</u></b>					
3 Meters SAC	3M	ETS-Lindgren	N/A	2014.10.13	<input checked="" type="checkbox"/>
10 Meters SAC	10M	ETS-Lindgren	N/A	2015.06.05	<input checked="" type="checkbox"/>
EMI Test Receiver	ESL6	Rohde & Schwarz	100178	2015.04.01	<input checked="" type="checkbox"/>
Bi-Log Antenna	JB1	Sunol Sciences	A030702	2015.07.13	<input checked="" type="checkbox"/>
Horn Antenna	3115	EMCO	10SL0059	2015.04.26	<input checked="" type="checkbox"/>
Pre-Amplifier (9kHz-7GHz)	LPA-6-30	RF Bay, Inc.	11140711	2015.02.18	<input checked="" type="checkbox"/>
Pre-Amplifier (1-26.5GHz)	8449B	HP	3008A00715	2015.05.30	<input checked="" type="checkbox"/>
<b><u>RF Conducted Measurement</u></b>					
Spectrum Analyzer	N9010A	Agilent	MY50210206	2015.05.30	<input checked="" type="checkbox"/>
Spectrum Analyzer	E4407B	Agilent	US88441016	2015.05.31	<input checked="" type="checkbox"/>
R & S Receiver	ESIB 40	Rohde & Schwarz	100179	2015.04.20	<input checked="" type="checkbox"/>







Test report No.	FCC_RF_SL14070701-HID-019_RFID Rev1.0
Page	41 of 43

## **Annex B. USER MANUAL, BLOCK & CIRCUIT DIAGRAM**

Please see attachment

## Annex C. SIEMIC Accreditation

Accreditations	Document	Scope / Remark
ISO 17025 (A2LA)		Please see the documents for the detailed scope
ISO Guide 65 (A2LA)		Please see the documents for the detailed scope
TCB Designation		A1, A2, A3, A4, B1, B2, B3, B4, C
FCC DoC Accreditation		FCC Declaration of Conformity Accreditation
FCC Site Registration		3 meter site
FCC Site Registration		10 meter site
IC Site Registration		3 meter site
IC Site Registration		10 meter site
EU NB		<b>Radio &amp; Telecommunications Terminal Equipment:</b> EN45001 – EN ISO/IEC 17025
		<b>Electromagnetic Compatibility:</b> EN45001 – EN ISO/IEC 17025
Singapore iDA CB(Certification Body)		Phase I, Phase II
Vietnam MIC CAB Accreditation		Please see the document for the detailed scope
HongKong OFCA		<b>(Phase II)</b> OFCA Foreign Certification Body for Radio and Telecom
		<b>(Phase I)</b> Conformity Assessment Body for Radio and Telecom
Industry Canada CAB		<b>Radio:</b> Scope A – All Radio Standard Specification in Category I
		<b>Telecom:</b> CS-03 Part I, II, V, VI, VII, VIII

Japan Recognized Certification Body Designation		<p><b>Radio</b> : A1. Terminal equipment for purpose of calling</p> <p><b>Telecom</b> : B1. Specified radio equipment specified in Article 38-2, Paragraph 1, Item 1 of the Radio Law</p>
Korea CAB Accreditation		<p><b>EMI</b>: KCC Notice 2008-39, RRL Notice 2008-3: CA Procedures for EMI          KN22: Test Method for EMI  <b>EMS</b>: KCC Notice 2008-38, RRL Notice 2008-4: CA Procedures for EMS          KN24, KN61000-4-2, -4-3, -4-4, -4-5, -4-6, -4-8, -4-11: Test Method for EMS</p>
		<p><b>Radio</b>: RRL Notice 2008-26, RRL Notice 2008-2, RRL Notice 2008-10, RRL Notice 2007-49, RRL Notice 2007-20, RRL Notice 2007-21, RRL Notice 2007-80, RRL Notice 2004-68</p>
		<p><b>Telecom</b>: President Notice 20664, RRL Notice 2007-30, RRL Notice 2008-7 with attachments 1, 3, 5, 6; President Notice 20664, RRL Notice 2008-7 with attachment 4</p>
Taiwan NCC CAB Recognition		LP0002, PSTN01, ADSL01, ID0002, IS6100, CNS14336, PLMN07, PLMN01, PLMN08
Taiwan BSMI CAB Recognition		CNS 13438
Japan VCCI		R-3083: Radiation 3 meter site
		C-3421: Main Ports Conducted Interference Measurement
		T-1597: Telecommunication Ports Conducted Interference Measurement
Australia CAB Recognition		<p><b>EMC</b>: AS/NZS CISPR 11, AS/NZS CISPR 14.1, AS/NZS CISPR22, AS/NZS 61000.6.3, AS/NZS 61000.6.4</p>
		<p><b>Radiocommunications</b>: AS/NZS 4281, AS/NZS 4268, AS/NZS 4280.1, AS/NZS 4280.2, AS/NZS 4295, AS/NZS 4582, AS/NZS 4583, AS/NZS 4769.1, AS/NZS 4769.2, AS/NZS 4770, AS/NZS 4771</p>
		<p><b>Telecommunications</b>: AS/ACIF S002:05, AS/ACIF S003:06, AS/ACIF S004:06 AS/ACIF S006:01, AS/ACIF S016:01, AS/ACIF S031:01, AS/ACIF S038:01, AS/ACIF S040:01, AS/ACIF S041:05, AS/ACIF S043.2:06, AS/ACIF S60950.1</p>
Australia NATA Recognition		AS/ACIF S002, AS/ACIF S003, AS/ACIF S004, AS/ACIF S006, AS/ACIF S016, AS/ACIF S031, AS/ACIF S038, AS/ACIF S040, AS/ACIF S041, AS/ACIF S043.2