



041838  
Rev. A  
10/2021

Please read before installing

Model Number

Ratings

**Important Notes:**

- Use copper conductors only.
- Check to see that the device type and rating is suitable for the application.
- **DO NOT** install if product has any visible damage.
- If moisture or condensation is evident, allow the product to dry completely before installation.
- Operate between 32 °F and 131 °F (0 °C and 55 °C), ambient.
- 0% to 90% humidity, non-condensing.
- For indoor use only.
- Sensor should be mounted to fixture in orientation that makes it parallel to the floor when fixture is installed in ceiling.
- Clean only with soft, damp cloth, no chemical cleaners.
- **DO NOT** paint.

**Default Functionality**

On power up performs a startup test sequence and will then stay at 100% intensity until associated to an Athena system.

English

**\* For set-up, programming, and troubleshooting please refer to the installation instructions included with the hub or at www.lutron.com**

**FCC information and IC information**

This device complies with part 15 of the FCC Rules and Industry Canada license-exempt RSS standard(s). Operation is subject to the following two conditions: (1) This device may not cause interference, and (2) this device must accept any interference, including interference that may cause undesired operation. Modifications not expressly approved by Lutron Electronics Co., Inc. could void the user's authority to operate this equipment.

**NOTE:** This equipment has been tested and found to comply with the limits for a Class B digital device, pursuant to part 15 of the FCC Rules. These limits are designed to provide reasonable protection against harmful interference in a residential installation. This equipment generates, uses and can radiate radio frequency energy and, if not installed and used in accordance with the instructions, may cause harmful interference to radio communications. However, there is no guarantee that interference will not occur in a particular installation. If this equipment does cause harmful interference to radio or television reception, which can be determined by turning the equipment off and on, the user is encouraged to try to correct the interference by one or more of the following measures:

- Re-orient or relocate the receiving antenna.
- Increase the separation between the equipment and receiver.
- Connect the equipment into an outlet on a circuit different from that to which the receiver is connected.

This equipment complies with FCC/ISED radiation exposure limits set forth for an uncontrolled environment. The user should avoid prolonged exposure within 20 cm of the antenna, which may exceed FCC/ISED radio frequency exposure limits.

**Required Components**

For each fixture, you will need:

**One Interface**

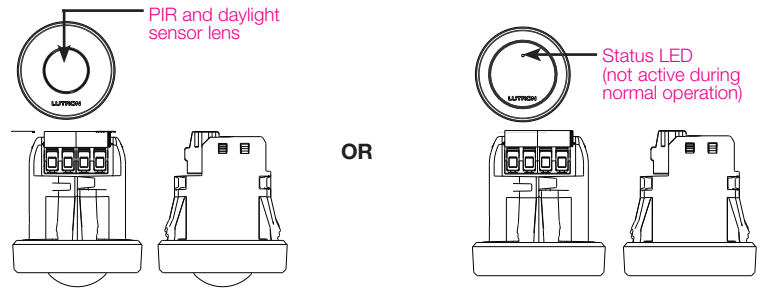

At least one driver with self-powered DALI link

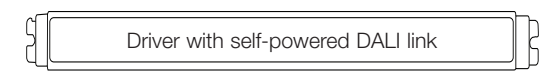

**Start Here**

**1. Connect Wires using Diagram Below**

- Vive Integral Fixture control contains two 18 AWG (0.75 mm<sup>2</sup>), solid copper wires.

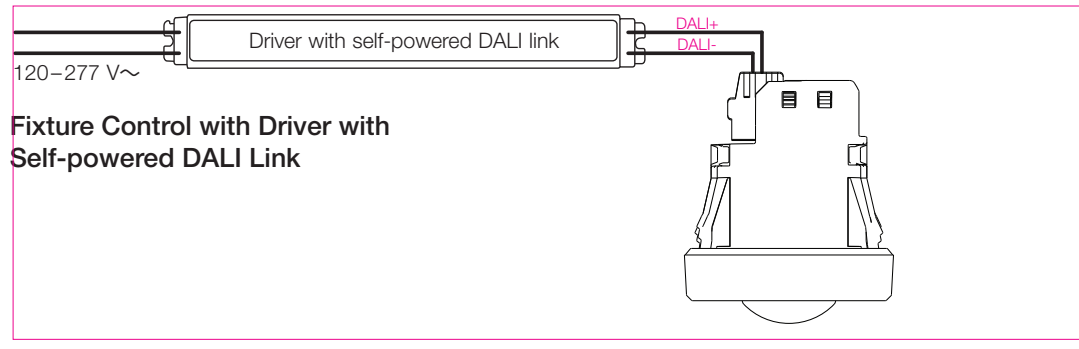

For applications that require more drivers than shown here, contact the driver manufacturer.

**Note:** When using multiple drivers with self-powered DALI link, DALI+ from the drivers must be tied together and the DALI- from the drivers must be tied together. Do NOT mix "+" and "-" when using multiple drivers.

\* Total supply current on the link not to exceed 250 mA

**2. Install Interface**

- Ensure knockout/cutout and adjacent surfaces are free from burrs, oil, chemicals, debris, etc.
- Do not push on the PIR lens to install
- Push firmly on the interface around the entire perimeter until it sits flush against the intended fixture mounting surface.
- Do not fully enclose within the metal fixture.
- Athena wireless node support solid and flexible conductors of 26-16 AWG (0.2-1.5 mm<sup>2</sup>).
- Wiring guide for

**3. Basic Functionality End-of-Line Test**

1. Provide power to the fixture.
2. Fixture will go to the driver's previous light level for 5 seconds.
3. Interface will automatically start its test sequence and cycle between the following states -
  - Maximum intensity, maximum cool color temperature
  - Maximum intensity, maximum warm color temperature
  - Minimum intensity, maximum warm color temperature
  - Maximum intensity, maximum cool color temperature
4. Remove power.

**Wiring Guide**

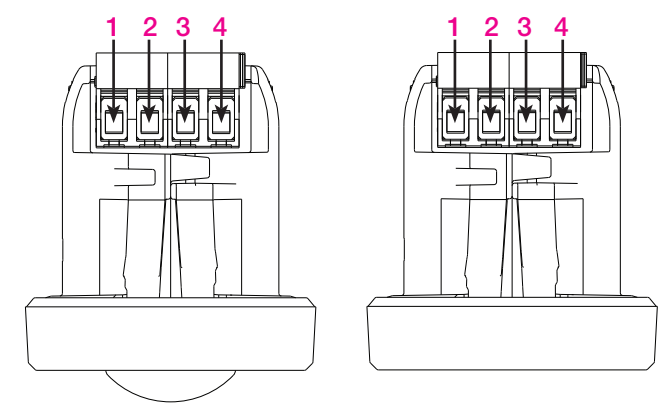

Connector Position	DALI Function	0-10V Function
1	DALI+	AUX+
2	DALI-	AUX-
3	N/C	SIG+
4	N/C	SIG-/DGND

**Troubleshooting\***

www.lutron.com/support

Symptom	Solution
Sensor does not respond to motion.	Not associated.
Lights do not dim or turn ON as expected.	Ensure that control lines are wired properly. Verify that the driver with self-powered DALI link has the DALI power supply activated. See driver manufacturer for details.
Lights are unstable at low-end.	Adjust low-end trim. Refer to Athena documentation on www.lutron.com.
The "Raise" button on the control does not increase the light level.	The lights cannot be raised above the Daylighting light level using a control. If it is critical to override the daylight level, disable daylighting from the Athena application.
End-of-Line Test does not affect color temperature of fixture.	Color temperature control is not supported in 0-10V control applications. If using DALI, confirm that driver supports color temperature control via IEC62386-209.

\*Note: These could apply to either the OEM or to the end customer.

5-year Warranty: http://www.lutron.com/TechnicalDocumentLibrary/3601321.pdf

French translation of the IC information

Information de la FCC/IC

Ce dispositif est conforme à la section 15 des règlements du FCC et des standards CNR exempt de licence d'Industrie Canada. L'opération est sous réserve des deux conditions suivantes :

- (1) Cet appareil ne peut causer d'interférence nuisible, et
- (2) Cet appareil doit tolérer toute interférence, même celle pouvant affecter son fonctionnement. Tout changement ou modification sans l'autorisation expresse de Lutron Electronics Co., Inc. pourrait annuler le droit d'utiliser cet équipement.

REMARQUE : Cet équipement a été testé et jugé conforme aux limites applicables aux dispositifs numériques Classe B, conformément à la section 15 des règles de la FCC. Ces limites sont conçues pour procurer une protection raisonnable contre les perturbations nuisibles en application résidentielle. Cet équipement génère, utilise et peut radier l'énergie de fréquences radiophoniques. S'il n'est pas installé et utilisé selon les directives, peut causer des interférences radiophoniques nuisibles. Cependant, il n'y a aucune garantie à l'effet qu'aucune interférence ne se produira dans une installation précise. Si votre équipement produit de l'interférence à la réception radiophonique ou télévisuelle, ce qui peut être détecté en coupant et refermant l'alimentation au système d'éclairage. Dans le cas d'interférence, l'utilisateur sera contraint d'essayer de corriger la situation par un ou plusieurs des moyens suivants :

- Réorienter ou re-localiser l'antenne de réception
- Augmenter la distance séparant l'équipement et le récepteur
- Brancher l'équipement sur un circuit différent que celui sur lequel le récepteur est branché
- Demander l'aide du distributeur ou d'un technicien expérimenté en radio et télévision

Cet équipement est conforme aux limites d'exposition aux radiations de la FCC définies pour un environnement non contrôlé. L'utilisateur doit éviter une exposition prolongée à moins de 20 cm de l'antenne, qui peut dépasser les limites d'exposition aux fréquences radio de la FCC.