



**FCC CFR47 PART 15 SUBPART C
INDUSTRY CANADA RSS-210 ISSUE 9**

SETUP PHOTOS

FOR

DIMMER MODULE

MODEL NUMBER: RMJS-ECO32-SZ

**FCC ID: JPZ0118
IC: 2851A-JPZ0118**

REPORT NUMBER: R12388606-E1

ISSUE DATE: 11 September 2018

**Prepared for
LUTRON ELECTRONICS CO., INC.
7200 SUTER ROAD
COOPERSBURG, PA 18036, USA**

**Prepared by
UL LLC
12 LABORATORY DR.
RESEARCH TRIANGLE PARK, NC 27709 USA
TEL: (919) 549-1400**



Revision History

<u>Ver.</u>	<u>Issue Date</u>	<u>Revisions</u>	<u>Revised By</u>
1	2018-09-11	Initial Issue	Brian T. Kiewra

TABLE OF CONTENTS

1. SETUP DIAGRAM FOR TESTS	4
2. SETUP PHOTOS.....	5
END OF REPORT	10

1. SETUP DIAGRAM FOR TESTS

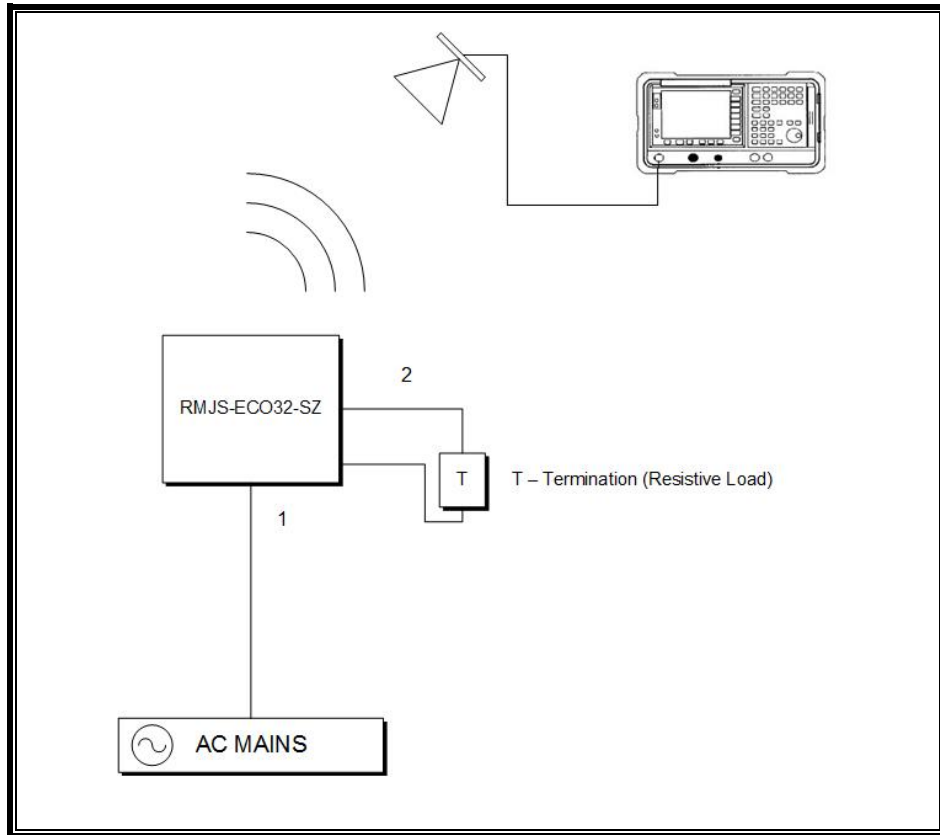

2. SETUP PHOTOS

ANTENNA PORT

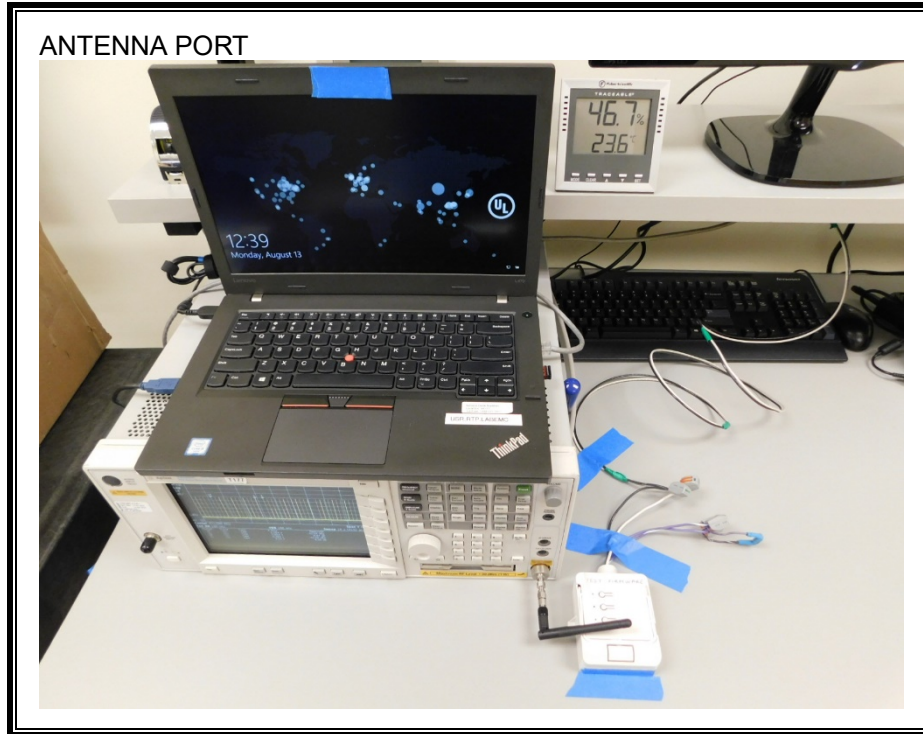

RADIATED EMISSIONS

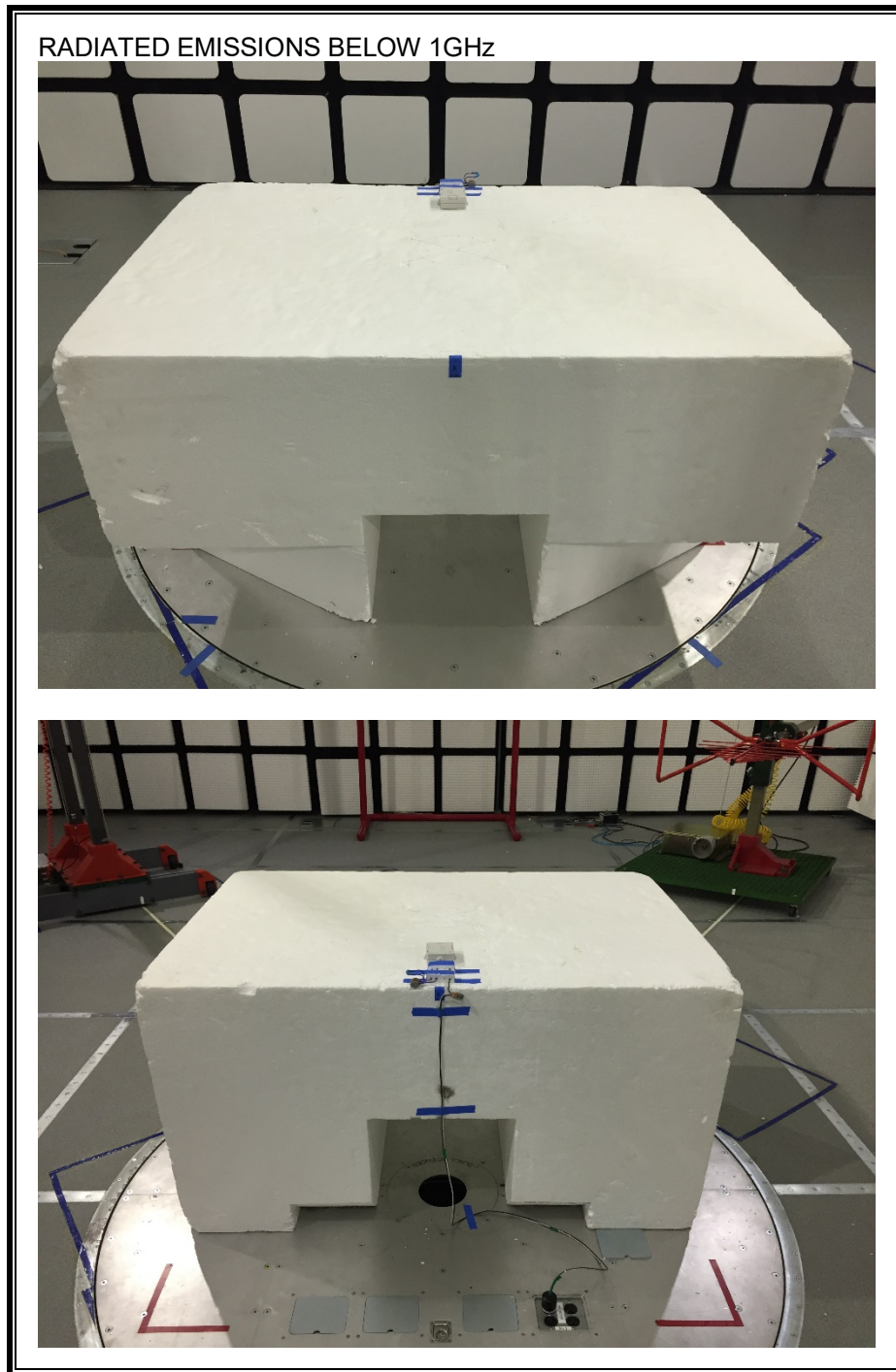

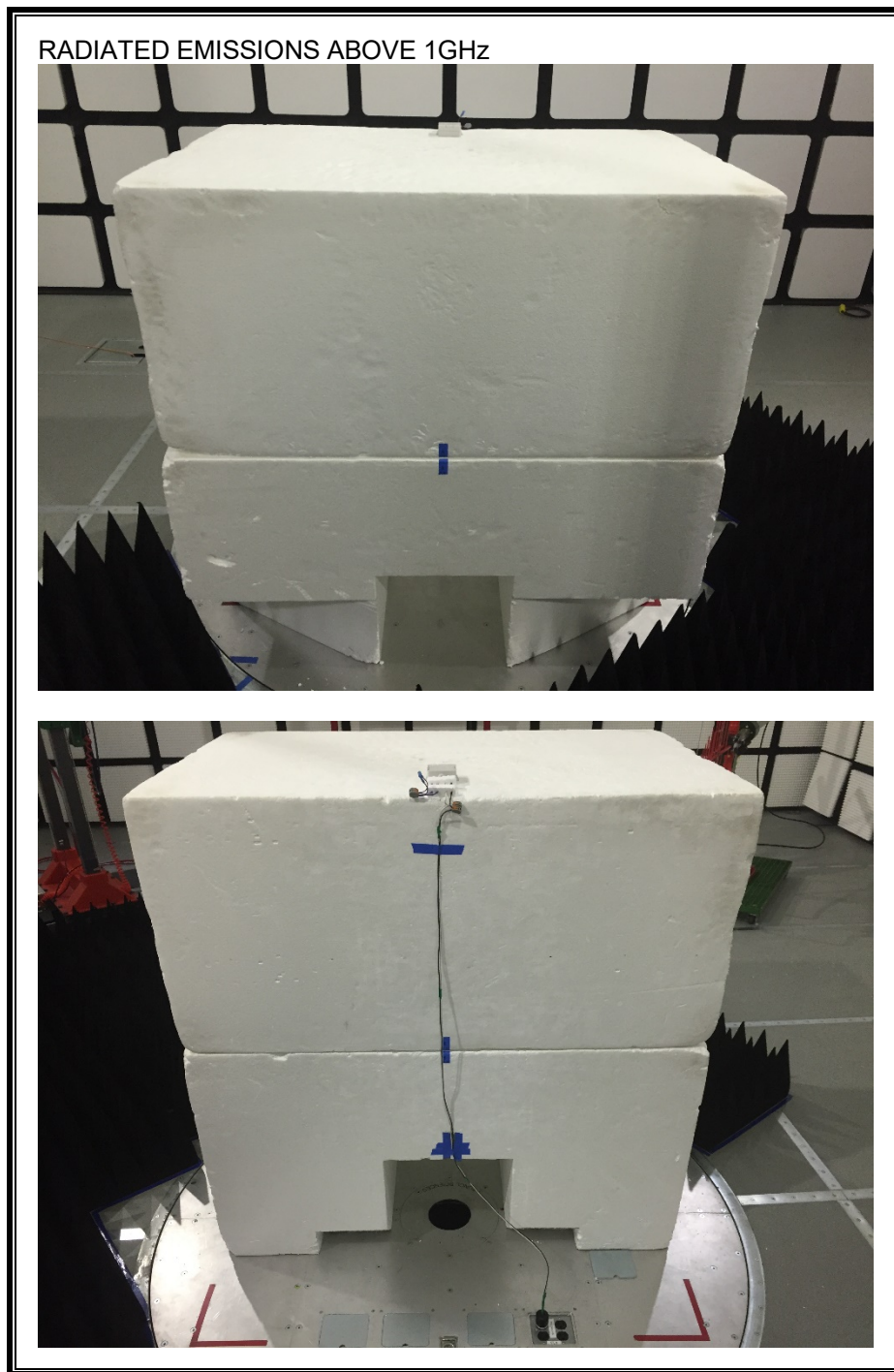

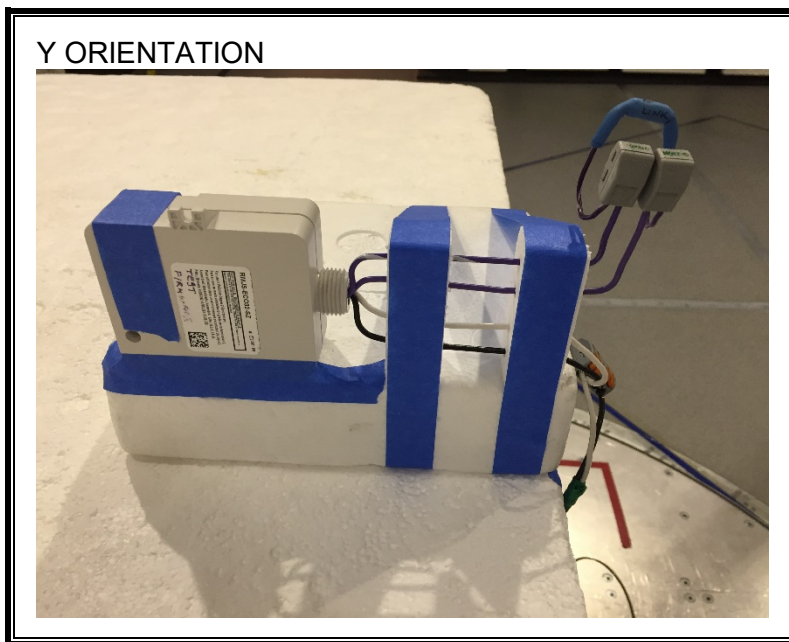
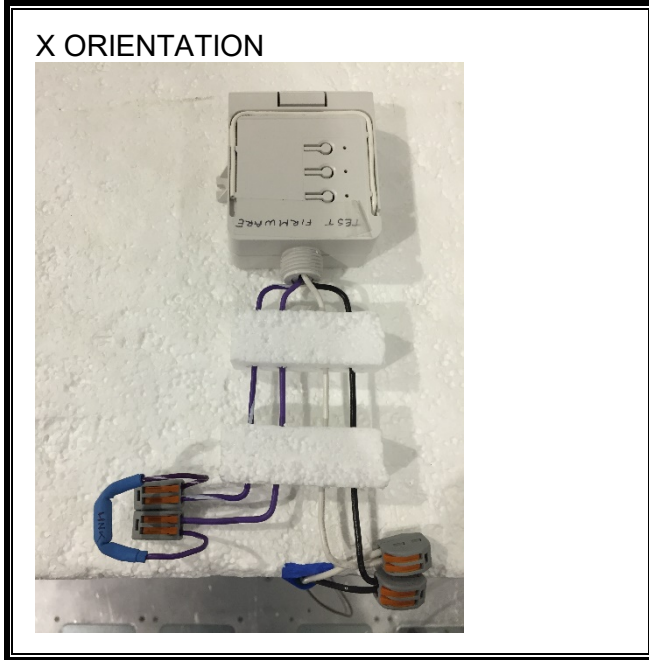



AC MAINS LINE CONDUCTED EMISSION

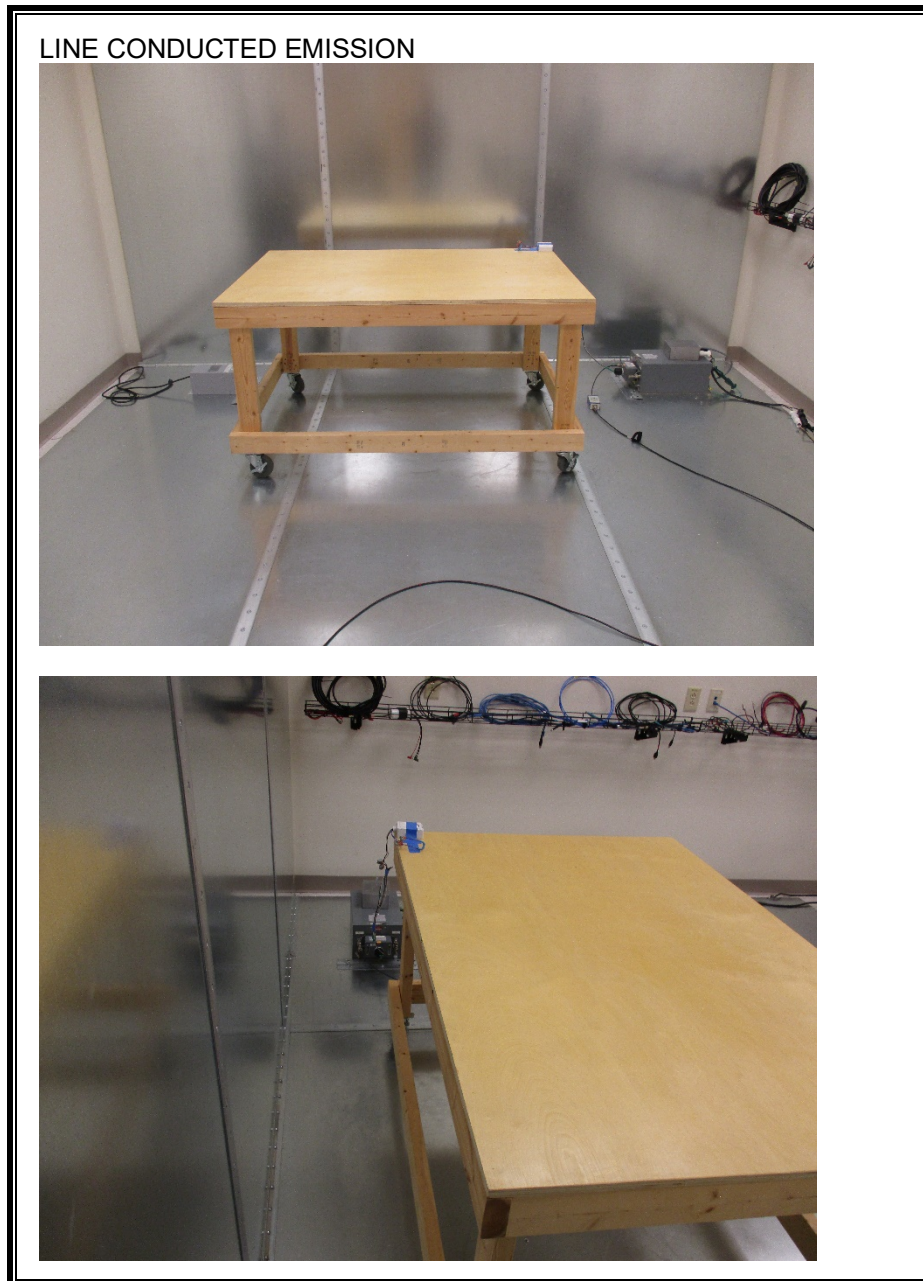

END OF REPORT