



MET Laboratories, Inc. *Safety Certification - EMI - Telecom Environmental Simulation*

914 WEST PATAPSCO AVENUE • BALTIMORE, MARYLAND 21230-3432 • PHONE (410) 354-3300 • FAX (410) 354-3313
33439 WESTERN AVENUE • UNION CITY, CALIFORNIA 94587 • PHONE (510) 489-6300 • FAX (510) 489-6372
3162 BELICK STREET • SANTA CLARA, CA 95054 • PHONE (408) 748-3585 • FAX (510) 489-6372
13501 MCCALLEN PASS • AUSTIN, TEXAS 78753 • PHONE (512) 287-2500 • FAX (512) 287-2513

May 4, 2017

Lutron Electronics Co., Inc.
7200 Suter Road
Coopersburg, PA 18036

Dear Dan Osle,

Enclosed is the EMC Wireless test report for compliance testing of the Lutron Electronics Co., Inc., Wireless Fixture Sensor as tested to the requirements of Title 47 of the CFR, Ch. 1 (10-1-06 ed.), FCC Part 15 Subpart C for Intentional Radiators.

Thank you for using the services of MET Laboratories, Inc. If you have any questions regarding these results or if MET can be of further service to you, please feel free to contact me.

Sincerely yours,
MET LABORATORIES, INC.

Jennifer Warnell
Documentation Department

Reference: (\Lutron Electronics Co., Inc.\EMC93815-FCC231 Rev. 2)

Certificates and reports shall not be reproduced except in full, without the written permission of MET Laboratories, Inc. .



MET Laboratories, Inc. *Safety Certification - EMI - Telecom Environmental Simulation*

914 WEST PATAPSCO AVENUE • BALTIMORE, MARYLAND 21230-3432 • PHONE (410) 354-3300 • FAX (410) 354-3313

33439 WESTERN AVENUE • UNION CITY, CALIFORNIA 94587 • PHONE (510) 489-6300 • FAX (510) 489-6372

3162 BELICK STREET • SANTA CLARA, CA 95054 • PHONE (408) 748-3585 • FAX (510) 489-6372

13501 MCCALLEN PASS • AUSTIN, TEXAS 78753 • PHONE (512) 287-2500 • FAX (512) 287-2513

**Electromagnetic Compatibility Criteria
Test Report**

for the

**Lutron Electronics Co., Inc.
Wireless Fixture Sensor**

Tested under
the FCC Certification Rules
contained in
Title 47 of the CFR, Part 15.231 Subpart C
for Intentional Radiators

MET Report: EMC93815-FCC231 Rev. 2

May 4, 2017

Prepared For:

**Lutron Electronics Co., Inc.
7200 Suter Road
Coopersburg, PA 18036**

Prepared By:
MET Laboratories, Inc.
914 W. Patapsco Ave.
Baltimore, MD 21230

Electromagnetic Compatibility Criteria Test Report

for the

Lutron Electronics Co., Inc.
Wireless Fixture Sensor

Tested under
the FCC Certification Rules
contained in
Title 47 of the CFR, Part 15.231 Subpart C
for Intentional Radiators



Djed Mouada, Project Engineer
Electromagnetic Compatibility Lab



Jennifer Warnell
Documentation Department

Engineering Statement: The measurements shown in this report were made in accordance with the procedures indicated, and the emissions from this equipment were found to be within the limits applicable. I assume full responsibility for the accuracy and completeness of these measurements, and for the qualifications of all persons taking them. It is further stated that upon the basis of the measurements made, the equipment tested is capable of operation in accordance with the requirements of FCC Rules Part 15.231 under normal use and maintenance.



Asad Bajwa,
Director, Electromagnetic Compatibility Lab

Report Status Sheet

Revision	Report Date	Reason for Revision
∅	April 7, 2017	Initial Issue.
1	April 18, 2017	Engineer corrections.
2	May 4, 2017	Corrections to Duty Cycle.

Table of Contents

I.	Executive Summary	1
	A. Purpose of Test	2
	B. Executive Summary	2
II.	Equipment Configuration	3
	A. Overview	4
	B. References	5
	C. Test Site	5
	D. Description of Test Sample	5
	E. Equipment Configuration	6
	F. Support Equipment	6
	G. Ports and Cabling Information	6
	H. Mode of Operation	6
	I. Modifications	6
	a) Modifications to EUT	6
	b) Modifications to Test Standard	6
	J. Disposition of EUT	6
III.	Electromagnetic Compatibility Criteria for Intentional Radiators	7
	§ 15.203 Antenna Requirement	8
	§ 15.207(a) Conducted Emissions Limits	9
	§ 15.231(a) Periodic Operation Requirements	12
	§ 15.231(c) Field Strength of Fundamental and Harmonics	16
	§ 15.231(c) 20dB Bandwidth	22
IV.	Test Equipment	24
V.	Certification & User's Manual Information	26
	A. Certification Information	27
	B. Label and User's Manual Information	31

List of Tables

Table 1. Executive Summary of EMC Part 15.231 Compliance Testing	2
Table 2. EUT Summary Table.....	4
Table 3. References	5
Table 4. Equipment Configuration	6
Table 5. Support Equipment.....	6
Table 6. Ports and Cabling Information	6
Table 7. Conducted Limits for Intentional Radiators from FCC Part 15 § 15.207(a)	9
Table 8. Conducted Emissions, 15.207(a), Phase Line, Test Results.....	10
Table 9. Conducted Emissions, 15.207(a), Neutral Line, Test Results	11
Table 10. Field Strength of Fundamental, Test Results.....	17
Table 11. 867 MHz Emission Investigation	17
Table 12. Test Equipment List	25

List of Plots

Plot 1. Conducted Emissions, 15.207(a), Phase Line.....	10
Plot 2. Conducted Emissions, 15.207(a), Neutral Line	11
Plot 3. Periodic Operation, 5sec. Requirements, Low Channel.....	13
Plot 4. Periodic Operation, 5sec. Requirements, High Channel	13
Plot 5. Duty Cycle, Period.....	14
Plot 6. Duty Cycle, 100ms Sweep	14
Plot 7. Duty Cycle, Burst On Time	15
Plot 8. Field Strength of Fundamental, Low Channel, 431.5 MHz	18
Plot 9. Field Strength of Fundamental, High Channel, 436.6 MHz	18
Plot 10. Spurious Emissions, 30 MHz – 1 GHz, Low Channel	19
Plot 11. Spurious Emissions, 30 MHz – 1 GHz, High Channel	19
Plot 12. Spurious Emissions, 1 GHz – 18 GHz, Average, Low Channel	20
Plot 13. Spurious Emissions, 1 GHz – 18 GHz, Average, High Channel	20
Plot 14. Spurious Emissions, 1 GHz – 18 GHz, Peak, Low Channel.....	21
Plot 15. Spurious Emissions, 1 GHz – 18 GHz, Peak, High Channel	21

List of Figures

Figure 1. Block Diagram of Test Configuration.....	5
--	---

List of Terms and Abbreviations

AC	Alternating Current
ACF	Antenna Correction Factor
Cal	Calibration
<i>d</i>	Measurement Distance
dB	Decibels
dBμA	Decibels above one microamp
dBμV	Decibels above one microvolt
dBμA/m	Decibels above one microamp per meter
dBμV/m	Decibels above one microvolt per meter
DC	Direct Current
E	Electric Field
EUT	Equipment Under Test
<i>f</i>	Frequency
FCC	Federal Communications Commission
GRP	Ground Reference Plane
H	Magnetic Field
HCP	Horizontal Coupling Plane
Hz	Hertz
kHz	kilohertz
kPa	kilopascal
kV	kilovolt
LISN	Line Impedance Stabilization Network
MHz	Megahertz
μH	microhenry
μ	microfarad
μs	microseconds
PRF	Pulse Repetition Frequency
RF	Radio Frequency
RMS	Root-Mean-Square
TWT	Traveling Wave Tube
V/m	Volts per meter
VCP	Vertical Coupling Plane

I. Executive Summary

A. Purpose of Test

An EMC evaluation was performed to determine compliance of the Lutron Electronics Co., Inc. Wireless Fixture Sensor, with the requirements of Part 15, §15.231. All references are to the most current version of Title 47 of the Code of Federal Regulations in effect. In accordance with §2.1033, the following data is presented in support of the Certification of the Wireless Fixture Sensor. Lutron Electronics Co., Inc. should retain a copy of this document which should be kept on file for at least two years after the manufacturing of the Wireless Fixture Sensor, has been **permanently** discontinued.

B. Executive Summary

The following tests were conducted on a sample of the equipment for the purpose of demonstrating compliance with Part 15, §15.231, in accordance with Lutron Electronics Co., Inc., purchase order number 5142425. All tests were conducted using measurement procedure ANSI C63.4-2014.

FCC Reference	Description	Results
§15.203	Antenna Requirement	Compliant
§15.207(a)	Conducted Emission Limits	Compliant
§15.231(a)	Periodic Operation Requirements	Compliant
§15.231(b)	Field Strength of Fundamentals and Harmonics	Compliant
§15.231(c)	20dB Bandwidth	Compliant

Table 1. Executive Summary of EMC Part 15.231 Compliance Testing

II. Equipment Configuration

A. Overview

MET Laboratories, Inc. was contracted by Lutron Electronics Co., Inc. to perform testing on the Wireless Fixture Sensor, under Lutron Electronics Co., Inc.'s purchase order number 5142425.

This document describes the test setups, test methods, required test equipment, and the test limit criteria used to perform compliance testing of the Lutron Electronics Co., Inc., Wireless Fixture Sensor.

The results obtained relate only to the item(s) tested.

Model(s) Tested:	Wireless Fixture Sensor	
Model(s) Covered:	Wireless Fixture Sensor	
EUT Specifications:	Primary Power: 20.5 VDC	
	FCC ID: JPZ0116	
	Max Field Strength:	79.38 dB μ V/m
	EUT Frequency Ranges:	431.5 MHz and 436.6 MHz
Analysis:	The results obtained relate only to the item(s) tested.	
Environmental Test Conditions:	Temperature: 15-35° C	
	Relative Humidity: 30-60%	
	Barometric Pressure: 860-1060 mbar	
Evaluated by:	Djed Mouada	
Report Date(s):	May 4, 2017	

Table 2. EUT Summary Table

B. References

CFR 47, Part 15, Subpart C	Federal Communication Commission, Code of Federal Regulations, Title 47, Part 15: General Rules and Regulations, Allocation, Assignment, and Use of Radio Frequencies
ANSI C63.4:2014	Methods and Measurements of Radio-Noise Emissions from Low-Voltage Electrical And Electronic Equipment in the Range of 9 kHz to 40 GHz
ISO/IEC 17025:2005	General Requirements for the Competence of Testing and Calibration Laboratories
ANSI C63.10-2013	American National Standard for Testing Unlicensed Wireless Devices

Table 3. References

C. Test Site

All testing was performed at MET Laboratories, Inc., 914 W. Patapsco Ave., Baltimore, MD 21230. All equipment used in making physical determinations is accurate and bears recent traceability to the National Institute of Standards and Technology.

Radiated Emissions measurements were performed in a 3 meter semi-anechoic chamber (equivalent to an Open Area Test Site). In accordance with §2.948(a)(3), a complete site description is contained at MET Laboratories.

D. Description of Test Sample

The Wireless Fixture Sensor (referred to as EUT hereafter) is a Luminaire or ceiling tile mounted sensor. Device contains an FM transceiver and an antenna, which is not accessible to the user. The purpose of the RF communication is to receive command signals and transmit status back to the lighting control system.

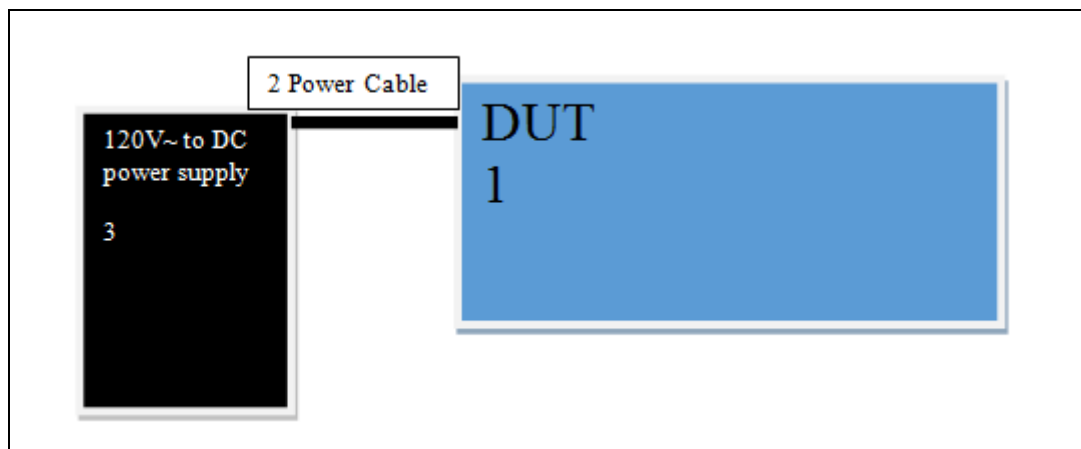

Figure 1. Block Diagram of Test Configuration

E. Equipment Configuration

Ref. ID	Slot #	Name / Description	Model Number	Part Number	Serial Number	Revision
1	1	DUT	DFCSJ-OEM-OCC	--	--	A

Table 4. Equipment Configuration

F. Support Equipment

Ref. ID	Name / Description	Manufacturer	Model Number
3	AC to DC power supply	Glacial Power	GP-DP004N-16V

Table 5. Support Equipment

G. Ports and Cabling Information

Ref. ID	Port name on EUT	Cable Description or reason for no cable	Qty.	Length as tested (m)	Max Length (m)	Shielded? (Y/N)	Termination Box ID & Port Name
2	DC Input	2 conductor, 18 awg	1	2		No	

Table 6. Ports and Cabling Information

H. Mode of Operation

Agency Software, will select between Constant Wave, Constant Packet, Constant Transmit modes of Wireless operation. Will also allow the selection of High Low and Center channel in the 431-437 MHz range

As shipped software will behave as a normal device to be used for bandwidth

Devices with both software images will be provide one with the antenna installed another with and SMA connector for conducted testing.

I. Modifications

a) Modifications to EUT

No modifications were made to the EUT.

b) Modifications to Test Standard

No modifications were made to the test standard.

J. Disposition of EUT

The test sample including all support equipment submitted to the Electro-Magnetic Compatibility Lab for testing was returned to Lutron Electronics Co., Inc. upon completion of testing.

III. Electromagnetic Compatibility Criteria for Intentional Radiators

Electromagnetic Compatibility Criteria for Intentional Radiators

§ 15.203 Antenna Requirement

Test Requirement: § 15.203: An intentional radiator shall be designed to ensure that no antenna other than that furnished by the responsible party shall be used with the device. The use of a permanently attached antenna or of an antenna that uses a unique coupling to the intentional radiator shall be considered sufficient to comply with the provisions of this section. The manufacturer may design the unit so that a broken antenna can be replaced by the user, but the use of a standard antenna jack or electrical connector is prohibited.

The structure and application of the EUT were analyzed to determine compliance with Section 15.203 of the Rules. Section 15.203 states that the subject device must meet at least one of the following criteria:

- a.) Antenna must be permanently attached to the unit.
- b.) Antenna must use a unique type of connector to attach to the EUT.
- c.) Unit must be professionally installed. Installer shall be responsible for verifying that the correct antenna is employed with the unit.

Results: The EUT as tested is compliant the criteria of §15.203. The EUT has an integral antenna.

Test Engineer(s): Djed Mouada

Test Date(s): 03/20/17

Electromagnetic Compatibility Criteria for Intentional Radiators

§ 15.207(a) Conducted Emissions Limits

Test Requirement(s): § 15.207 (a): For an intentional radiator that is designed to be connected to the public utility (AC) power line, the radio frequency voltage that is conducted back onto the AC power line on any frequency or frequencies, within the band 150 kHz to 30MHz, shall not exceed the limits in the following table, as measured using a 50 μ H/50 Σ line impedance stabilization network (LISN). Compliance with the provisions of this paragraph shall be based on the measurement of the radio frequency voltage between each power line and ground at the power terminal. The lower limit applies at the boundary between the frequency ranges.

Frequency range (MHz)	§ 15.207(a), Conducted Limit (dB μ V)	
	Quasi-Peak	Average
* 0.15- 0.45	66 - 56	56 - 46
0.45 - 0.5	56	46
0.5 - 30	60	50

Table 7. Conducted Limits for Intentional Radiators from FCC Part 15 § 15.207(a)

Test Procedure: The EUT was placed on a 0.8 m-high wooden table inside a screen room. The EUT was situated such that the back of the EUT was 0.4 m from one wall of the vertical ground plane, and the remaining sides of the EUT were no closer than 0.8 m from any other conductive surface. The EUT was powered from a 50 Ω /50 μ H Line Impedance Stabilization Network (LISN). The EMC receiver scanned the frequency range from 150 kHz to 30 MHz. Conducted Emissions measurements were made in accordance with *ANSI C63.4-2014 "Methods and Measurements of Radio-Noise Emissions from Low-Voltage Electrical and Electronic Equipment in the Range of 9kHz to 40 GHz"*. The measurements were performed over the frequency range of 0.15 MHz to 30 MHz using a 50 Ω /50 μ H LISN as the input transducer to an EMC/field intensity meter. For the purpose of this testing, the transmitter was turned on. Scans were performed with the transmitter on.

Test Results: The EUT was compliant with this requirement. Measured emissions were within applicable limits.

Test Engineer(s): Djed Mouada

Test Date(s): 03/20/17

15.207(a) Conducted Emissions Test Results

Frequency (MHz)	Uncorrected Meter Reading (dB μ V) QP	Cable Loss (dB)	Corrected Measurement (dB μ V) QP	Limit (dB μ V) QP	Margin (dB) QP	Uncorrected Meter Reading (dB μ V) Avg.	Cable Loss (dB)	Corrected Measurement (dB μ V) AVG	Limit (dB μ V) AVG	Margin (dB) AVG
0.162	48	0	48	65.36	-17.36	40.92	0	40.92	55.36	-14.44
0.322	27.92	0	27.92	59.66	-31.74	17.22	0	17.22	49.66	-32.44
0.6521	38.44	0	38.44	56	-17.56	33.22	0	33.22	46	-12.78
6.441	19.3	0	19.3	60	-40.7	11.45	0	11.45	50	-38.55
11.24	18.18	0	18.18	60	-41.82	10.03	0	10.03	50	-39.97
25.65	10.08	0	10.08	60	-49.92	3.32	0	3.32	50	-46.68

Table 8. Conducted Emissions, 15.207(a), Phase Line, Test Results

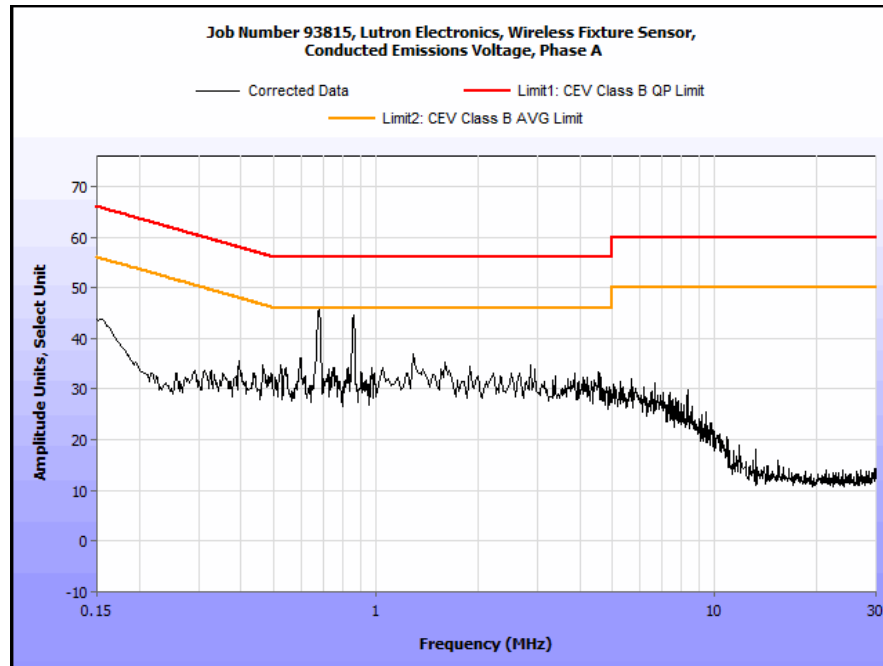

Plot 1. Conducted Emissions, 15.207(a), Phase Line

15.207(a) Conducted Emissions Test Results

Frequency (MHz)	Uncorrected Meter Reading (dBμV) QP	Cable Loss (dB)	Corrected Measurement (dBμV) QP	Limit (dBμV) QP	Margin (dB) QP	Uncorrected Meter Reading (dBμV) Avg.	Cable Loss (dB)	Corrected Measurement (dBμV) AVG	Limit (dBμV) AVG	Margin (dB) AVG
0.153	52	0	52	65.84	-13.84	41.94	0	41.94	55.84	-13.9
0.324	29.65	0	29.65	59.6	-29.95	16.32	0	16.32	49.6	-33.28
0.6788	41.88	0	41.88	56	-14.12	38.11	0	38.11	46	-7.89
5.365	22.94	0	22.94	60	-37.06	8.966	0	8.966	50	-41.034
10.2	16.18	0	16.18	60	-43.82	3.708	0	3.708	50	-46.292
20.98	7.195	0	7.195	60	-52.805	1.16	0	1.16	50	-48.84

Table 9. Conducted Emissions, 15.207(a), Neutral Line, Test Results

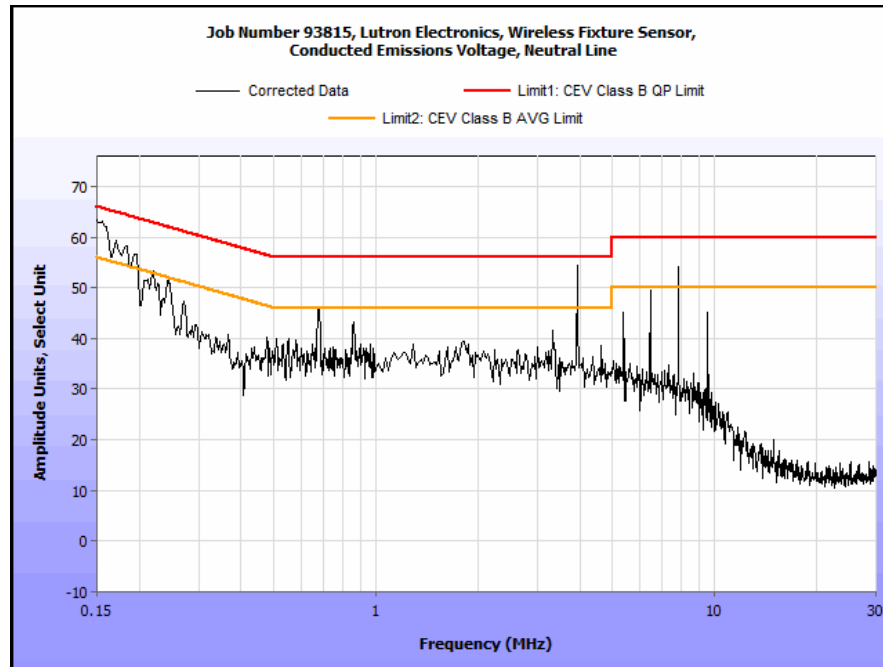

Plot 2. Conducted Emissions, 15.207(a), Neutral Line

Electromagnetic Compatibility Criteria for Intentional Radiators

§ 15.231 (a) Periodic Operation Requirements

- Test Requirement(s):** § 15.231 (a): (a) The provisions of this section are restricted to periodic operation within the band 40.66–40.70 MHz and above 70 MHz. Except as shown in paragraph (e) of this section, the intentional radiator is restricted to the transmission of a control signal such as those used with alarm systems, door openers, remote switches, etc. Continuous transmissions, voice, video and the radio control of toys are not permitted. Data is permitted to be sent with a control signal. The following conditions shall be met to comply with the provisions for this periodic operation: (1) A manually operated transmitter shall employ a switch that will automatically deactivate the transmitter within not more than 5 seconds of being released. (2) A transmitter activated automatically shall cease transmission within 5 seconds after activation.
- Test Procedure:** The EUT employs a manual switch. The switch on the EUT was released approximately 2 seconds into the sweep as shown below. As can be seen from the plot the EUT stops transmitting within 5 seconds. Marker 1 shows the end of transmission.
- Test Results:** The EUT was compliant with the requirements of this section.
- Test Engineer(s):** Djed Mouada
- Test Date(s):** 03/20/17

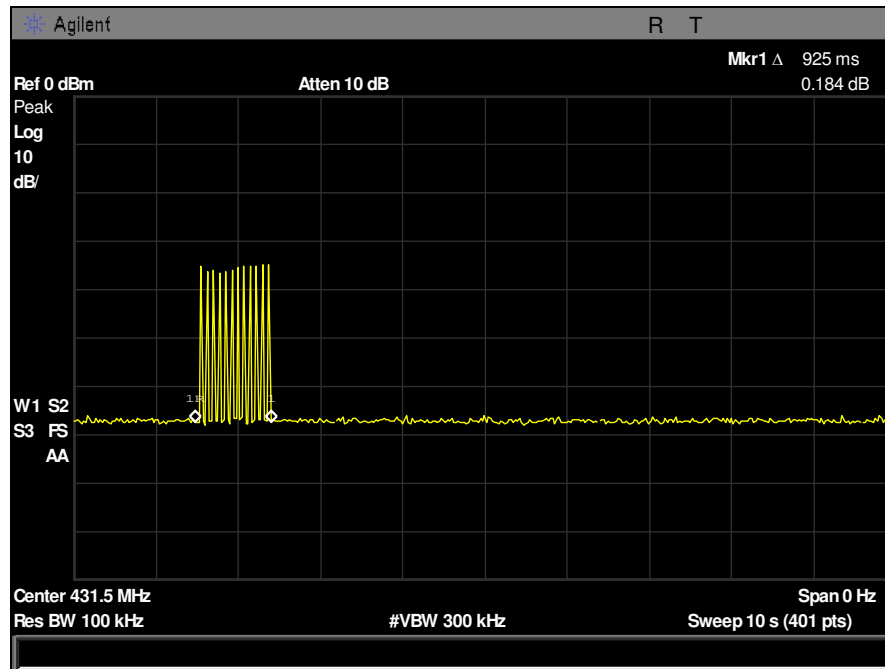

Plot 3. Periodic Operation, 5sec. Requirements, Low Channel

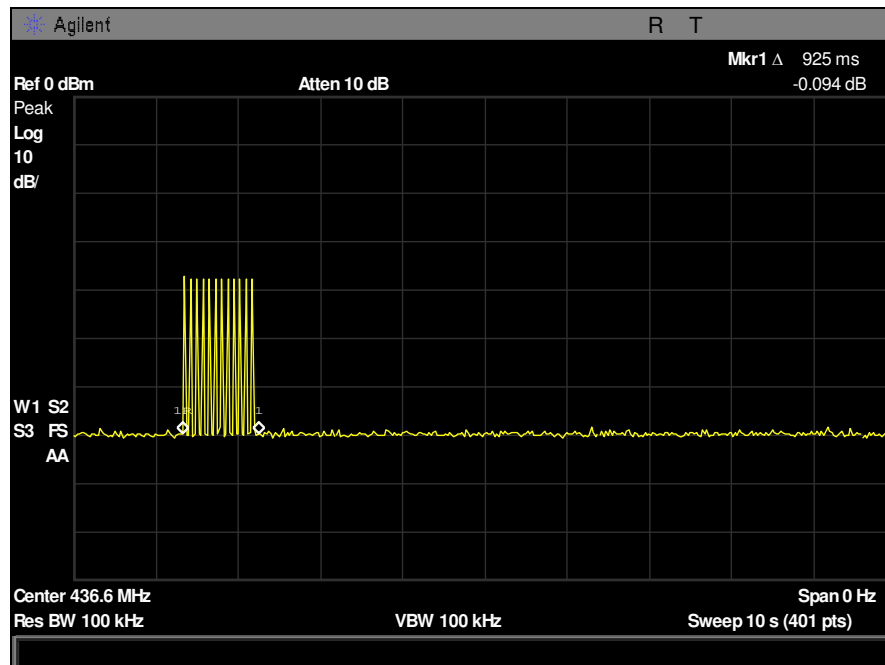

Plot 4. Periodic Operation, 5sec. Requirements, High Channel

Duty Cycle Calculation:

On time 5.133 ms

Number of bursts 2

DC = (5.133)/73.12= 7.0199%

Duty cycle correction factor $20 \log(0.10266)=23.03$ dB but the maximum DCCF is 20dB.

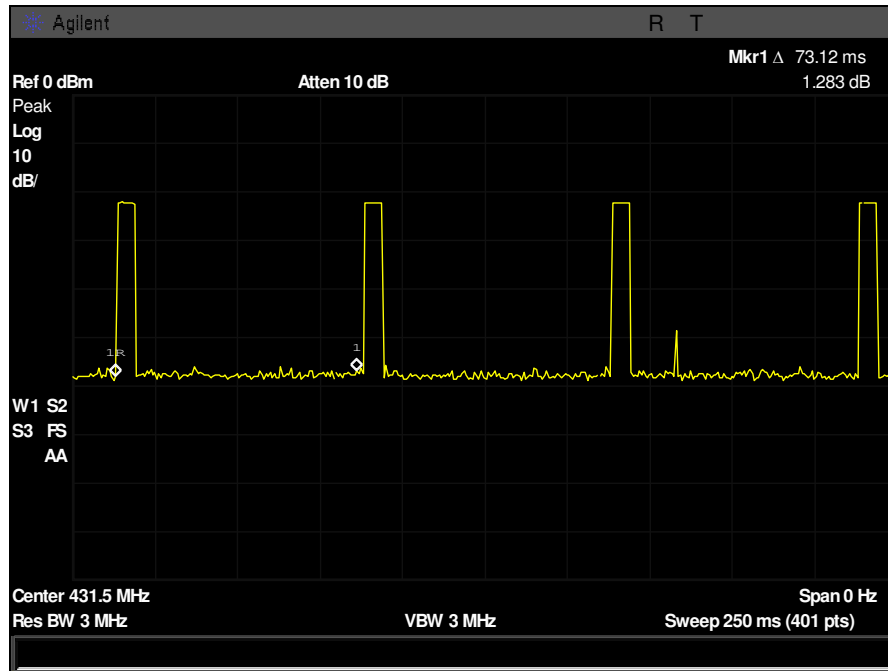

Plot 5. Duty Cycle, Period

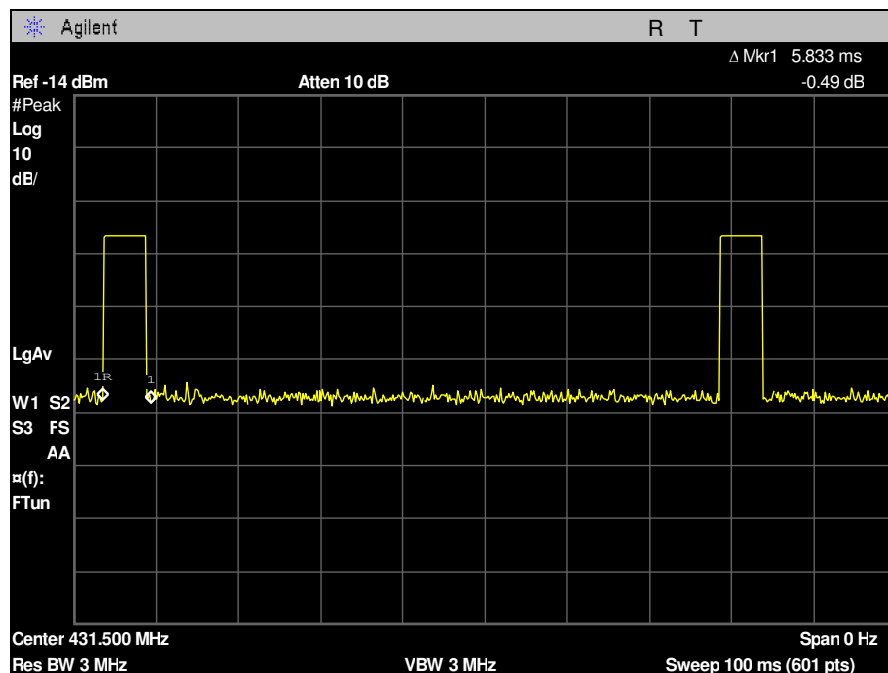

Plot 6. Duty Cycle, 100ms Sweep

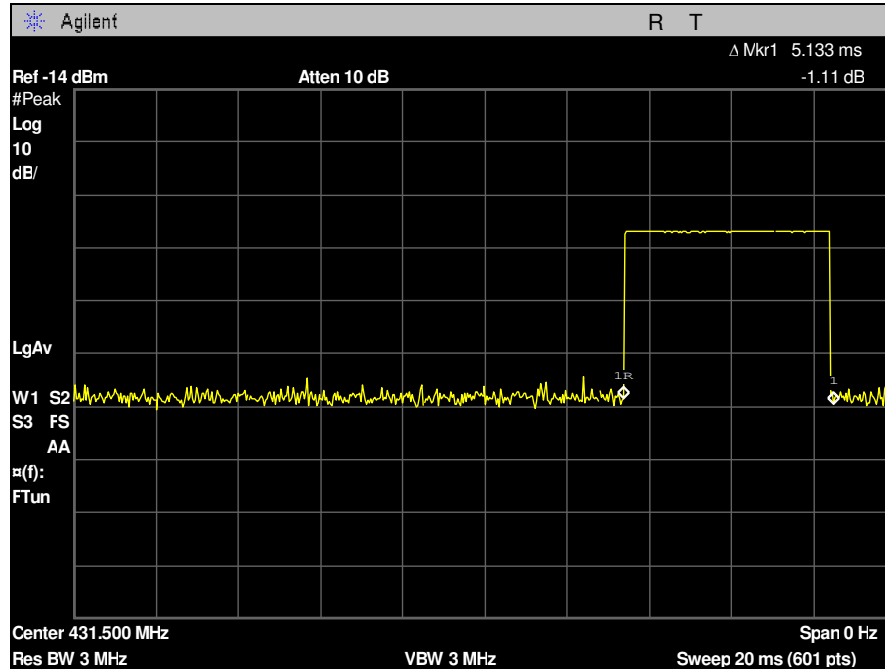

Plot 7. Duty Cycle, Burst On Time

Electromagnetic Compatibility Criteria for Intentional Radiators

§ 15.231(b) Field Strength of Fundamental and Harmonics

Test Requirements: §15.231(b): In addition to the provisions of §15.205, the field strength of emissions from intentional radiators operated under this section shall not exceed the following:

Fundamental frequency (MHz)	Field strength of fundamental (microvolts/ meter)	Field strength of spurious emissions (microvolts/meter)
40.66– 40.70	2,250	225
70–130	1,250	125
130–174	1,250* to 3,750	125* to 375
174–260	3,750	375
260–470	3,750* to 12,500	375* to 1,250
Above 470	12,500	1,250

Note: * Linear Interpolations

(1) The above field strength limits are specified at a distance of 3 meters. The tighter limits apply at the band edges. (2) Intentional radiators operating under the provisions of this section shall demonstrate compliance with the limits on the field strength of emissions, as shown in the above table, based on the average value of the measured emissions. As an alternative, compliance with the limits in the above table may be based on the use of measurement instrumentation with a CISPR quasi-peak detector. The specific method of measurement employed shall be specified in the application for equipment authorization. If average emission measurements are employed, the provisions in §15.35 for averaging pulsed emissions and for limiting peak emissions apply. Further, compliance with the provisions of §15.205 shall be demonstrated using the measurement instrumentation specified in that section. (3) The limits on the field strength of the spurious emissions in the above table are based on the fundamental frequency of the intentional radiator. Spurious emissions shall be attenuated to the average (or, alternatively, CISPR quasi-peak) limits shown in this table or to the general limits shown in §15.209, whichever limit permits a higher field strength.

The field strength limit determined by the fundamental frequency of the EUT of 431.5, MHz, and 436.6 MHz in accordance with 15.231(b), is not to exceed **80.74dBuV/m**, , and 80.91 dBuV/m respectively .

Test Procedure: The EUT was placed in a 3m semi anechoic chamber. A log periodic antenna was placed 3m from the EUT and used to measure the field strength of the fundamental. The EUT was rotated about all three orthogonal axis. The peak field strength was measured and then the average was calculated from the peak value by correcting for duty cycle. The correction factor as calculated above is -20 dB.

For harmonics measurements above 1 GHz, a horn antenna was used 1m from the EUT. A preamp was used to measure the harmonics.

Test Results: Equipment was compliant with § 15.231 (b).

Test Engineer(s): Djed Mouada

Test Date(s): 03/20/17

Frequency MHz	Measured Field Strength (dB μ V/m)	Duty Cycle Correction Factor (dB)	corrected Field Strength (dB μ V/m)	Field Strength Limit (dB μ V/m)	Margin
431.5	99.15	20	79.15	80.745	-1.5595
436.6	97.85	20	77.85	80.912	-3.062

Table 10. Field Strength of Fundamental, Test Results

Frequency (MHz)	EUT Azimuth (Degrees)	Antenna Polarity (H/V)	Antenna HEIGHT (m)	Uncorrected EMI Meter Reading (dBuV)	Antenna Correction Factor (dB/m) (+)	Cable Loss/Pre-amp (dB) (+)	Distance Correction Factor (dB) (-)	Corrected Amplitude (dBuV/m)	Limit (dBuV/m)	Margin (dB)	Pass/Fail
867.1818	169	H	1.4313	8.01	22.7	4.39	0	35.1	46	-10.9	pass
867.1818	169	V	1.4313	10.27	22.7	4.39	0	37.36	46	-8.64	pass

Table 11. 867 MHz Emission Investigation

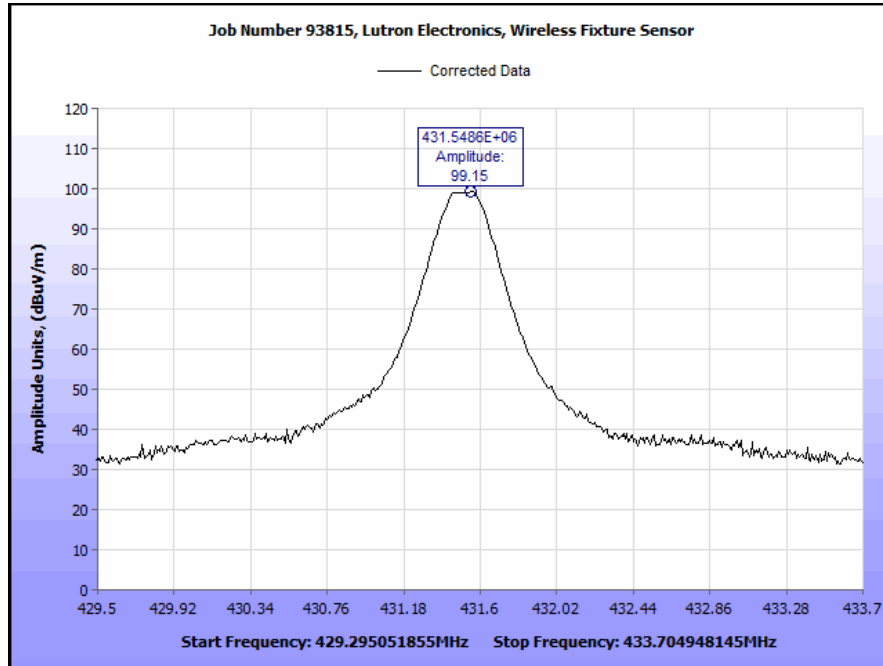

Plot 8. Field Strength of Fundamental, Low Channel, 431.5 MHz

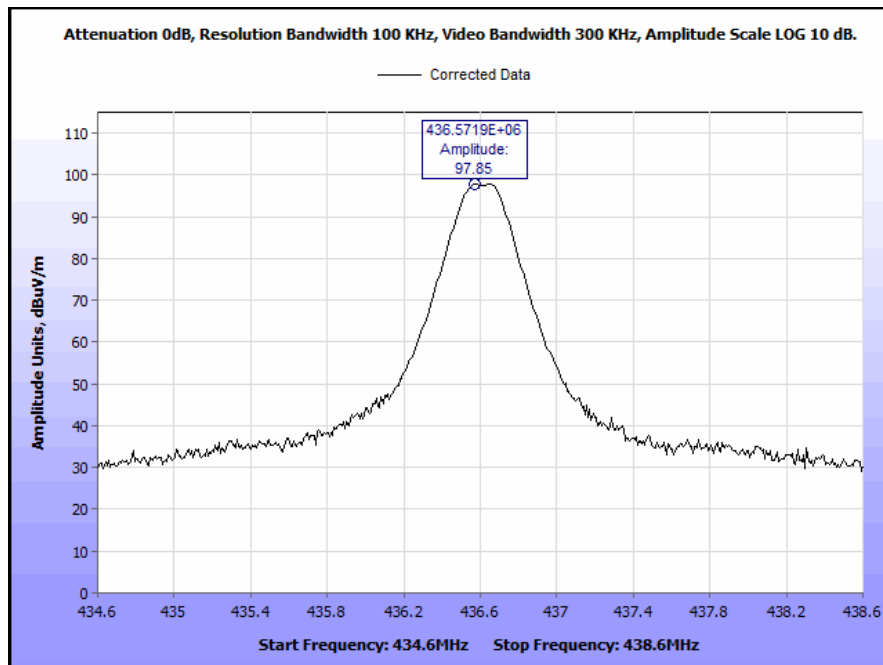

Plot 9. Field Strength of Fundamental, High Channel, 436.6 MHz

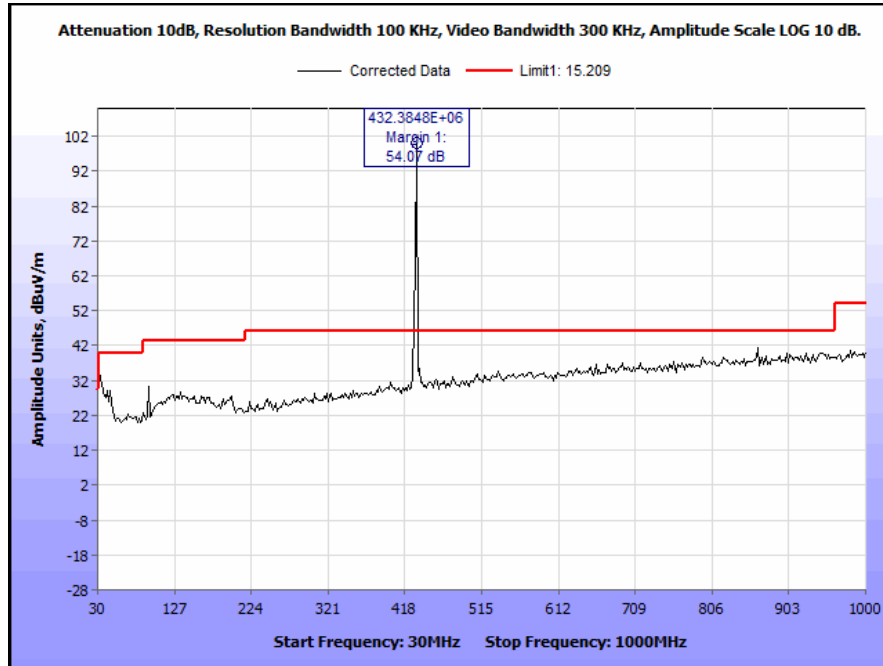

Plot 10. Spurious Emissions, 30 MHz – 1 GHz, Low Channel

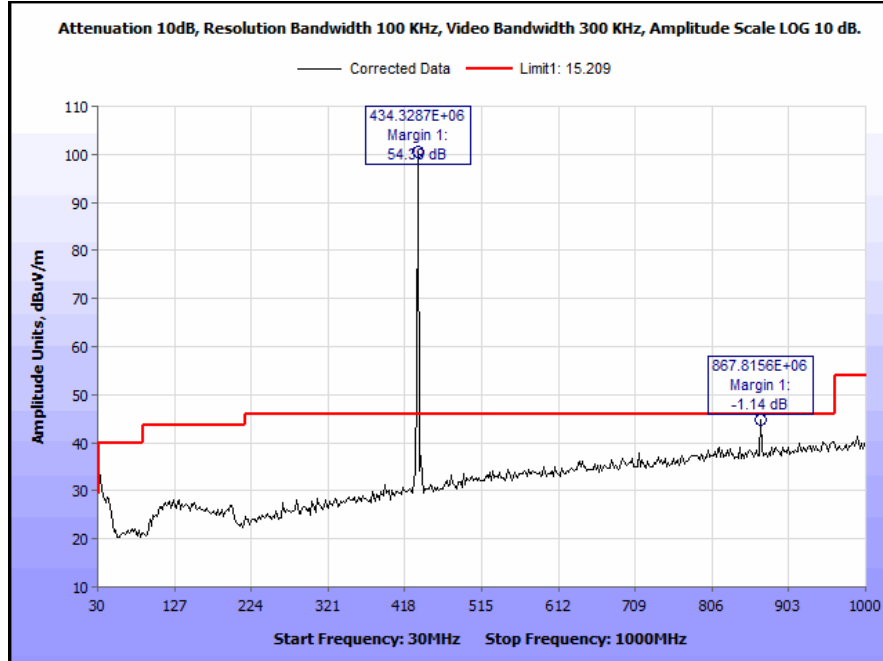

Plot 11. Spurious Emissions, 30 MHz – 1 GHz, High Channel

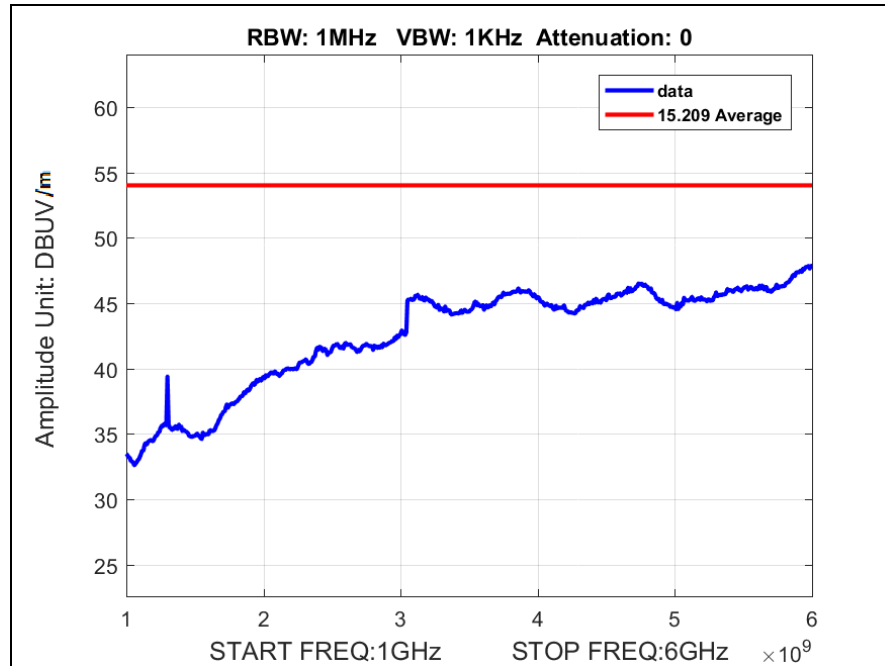

Plot 12. Spurious Emissions, 1 GHz – 18 GHz, Average, Low Channel

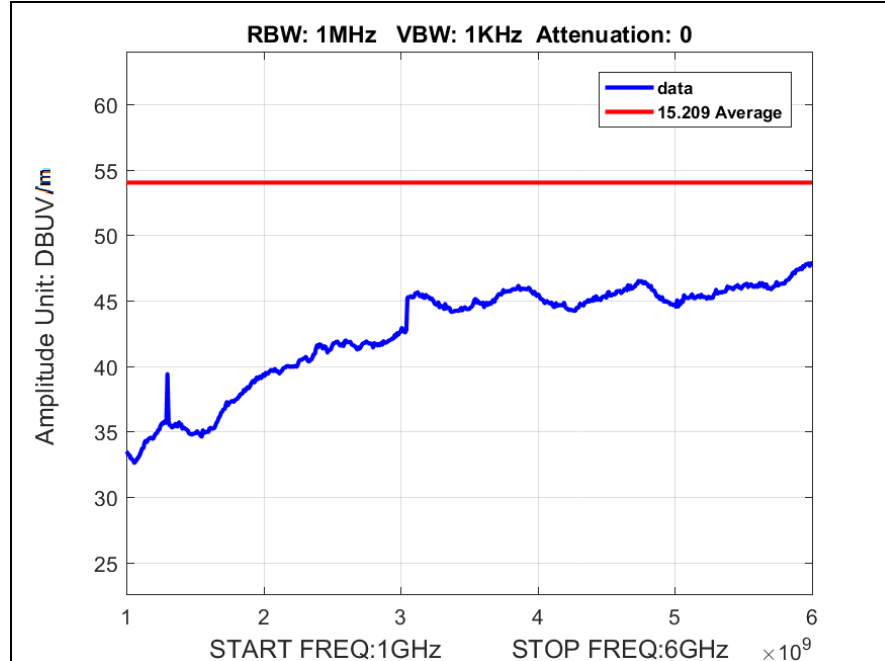

Plot 13. Spurious Emissions, 1 GHz – 18 GHz, Average, High Channel

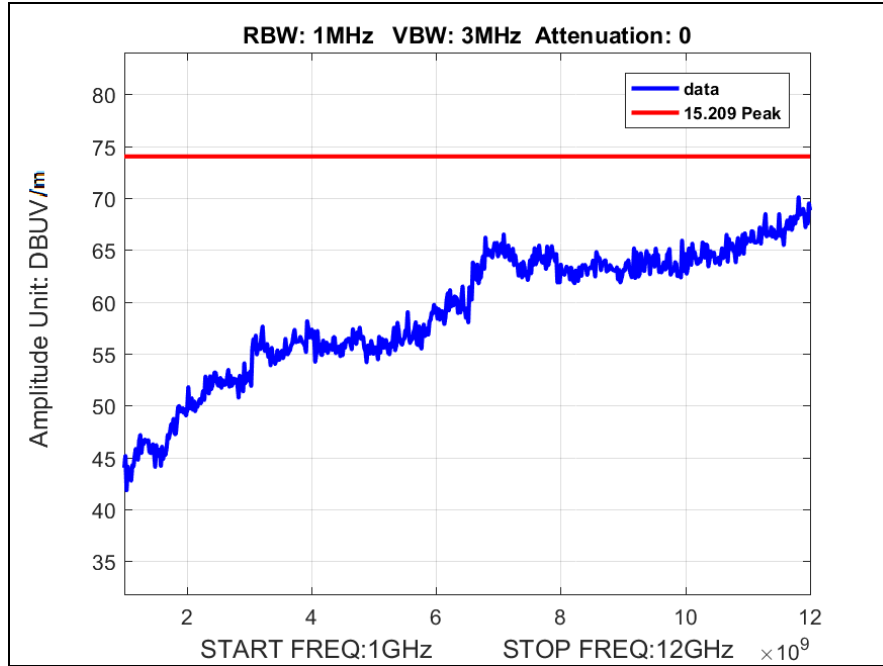

Plot 14. Spurious Emissions, 1 GHz – 18 GHz, Peak, Low Channel

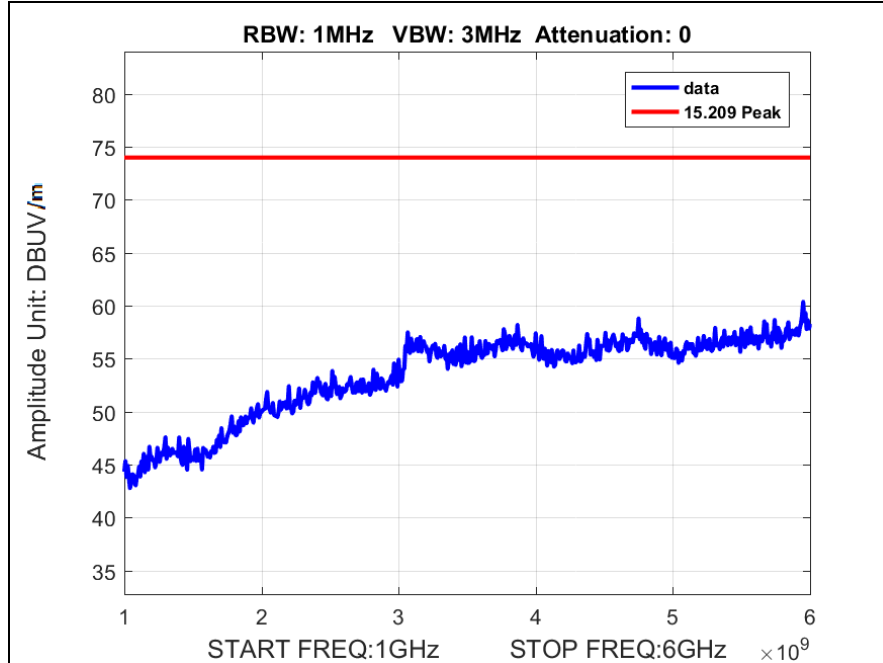

Plot 15. Spurious Emissions, 1 GHz – 18 GHz, Peak, High Channel

Electromagnetic Compatibility Criteria for Intentional Radiators

§ 15.231(c) 20dB Bandwidth

Test Requirements: §15.231(c): The bandwidth of the emission shall be no wider than 0.25% of the center frequency for devices operating above 70MHz and below 900MHz. For devices operating above 900MHz, the emission shall be no wider than 0.5% of the center frequency. Bandwidth is determined at the points 20dB down from the modulated carrier.

Test Results: Equipment was compliant with § 15.231(c).

Test Engineer(s): Djed Mouada

Test Date(s): 03/20/17

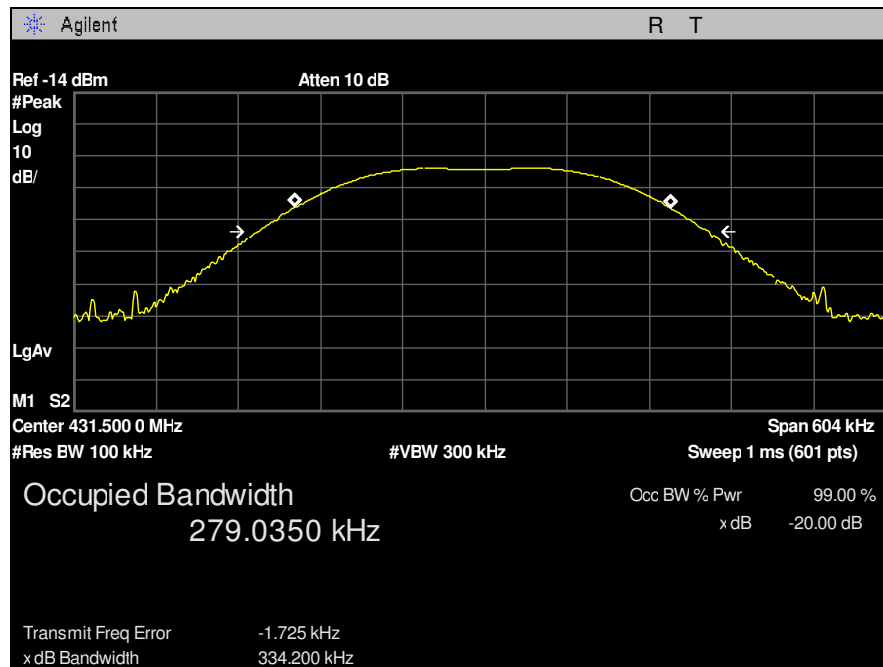

Plot 8. 20 dB Bandwidth, Low Channel

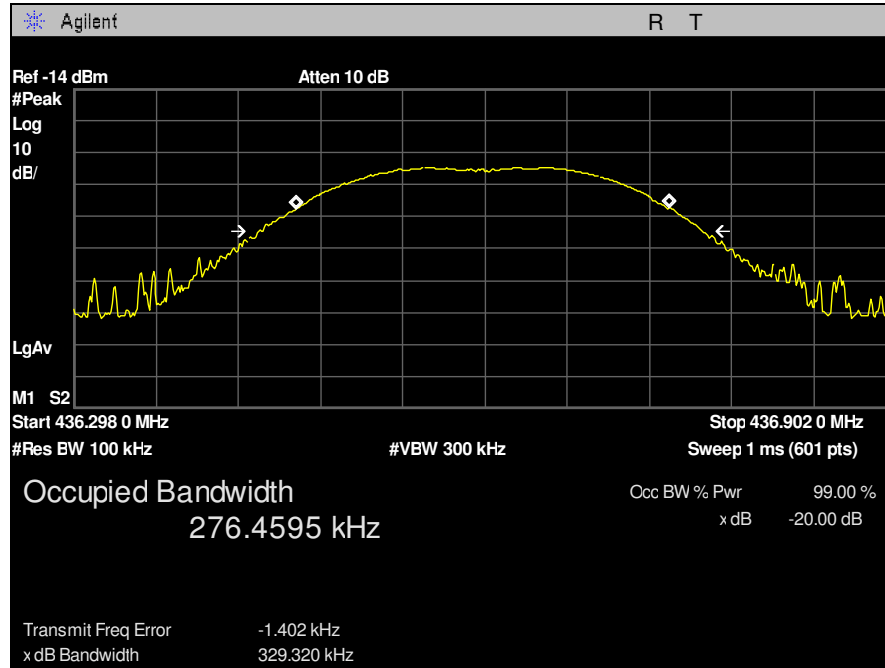

Plot 8. 20 dB Bandwidth, High Channel

IV. Test Equipment

Test Equipment

Calibrated test equipment utilized during testing was maintained in a current state of calibration per the requirements of ISO/IEC 17025:2005.

MET Asset #	Equipment	Manufacturer	Model	Last Cal Date	Cal Due Date
1T4829	SPECTRUM ANALYZER	AGILENT TECHNOLOGIES	E4407B	2/20/2017	2/20/2018
1T4212	LISN; SWITCH	SOLAR ELECTRONICS COMPANY	9252-R-24-BNC	2/15/2017	2/15/2018
1T4409	EMI RECEIVER	ROHDE & SCHWARZ	ESIB7	12/07/2016	12/07/2018
1T4753	ANTENNA - BILOG	SUNOL SCIENCES	JB6	10/24/2016	04/24/2018
1T4300B	SEMI-ANECHOIC 3M CHAMBER # 1 D (2043A-1) (IC)	EMC TEST SYSTEMS	NONE	01/11/2015	01/11/2018
1T4483	ANTENNA; HORN	ETS-LINDGREN	3117	10/08/2015	04/08/2017

Table 12. Test Equipment List

V. Certification & User's Manual Information

Certification & User's Manual Information

A. Certification Information

The following is extracted from Title 47 of the Code of Federal Regulations, Part 2, Subpart I — Marketing of Radio frequency devices:

§ 2.801 Radio-frequency device defined.

As used in this part, a radio-frequency device is any device which in its operation is capable of Emitting radio-frequency energy by radiation, conduction, or other means. Radio- frequency devices include, but are not limited to:

- (a) The various types of radio communication transmitting devices described throughout this chapter.
- (b) *The incidental, unintentional and intentional radiators defined in Part 15 of this chapter.*
- (c) The industrial, scientific, and medical equipment described in Part 18 of this chapter.
- (d) Any part or component thereof which in use emits radio-frequency energy by radiation, conduction, or other means.

§ 2.803 Marketing of radio frequency devices prior to equipment authorization.

- (a) Except as provided elsewhere in this chapter, no person shall sell or lease, or offer for sale or lease (including advertising for sale or lease), or import, ship or distribute for the purpose of selling or leasing or offering for sale or lease, any radio frequency device unless:
 - (1) In the case of a device subject to certification, such device has been authorized by the Commission in accordance with the rules in this chapter and is properly identified and labeled as required by §2.925 and other relevant sections in this chapter; or
 - (2) In the case of a device that is not required to have a grant of equipment authorization issued by the Commission, but which must comply with the specified technical standards prior to use, such device also complies with all applicable administrative (including verification of the equipment or authorization under a Declaration of Conformity, where required), technical, labeling and identification requirements specified in this chapter.
- (d) Notwithstanding the provisions of paragraph (a) of this section, the offer for sale solely to business, commercial, industrial, scientific or medical users (but not an offer for sale to other parties or to end users located in a residential environment) of a radio frequency device that is in the conceptual, developmental, design or pre-production stage is permitted prior to equipment authorization or, for devices not subject to the equipment authorization requirements, prior to a determination of compliance with the applicable technical requirements *provided* that the prospective buyer is advised in writing at the time of the offer for sale that the equipment is subject to the FCC rules and that the equipment will comply with the appropriate rules before delivery to the buyer or to centers of distribution.

- (e)(1) Notwithstanding the provisions of paragraph (a) of this section, prior to equipment authorization or determination of compliance with the applicable technical requirements any radio frequency device may be operated, but not marketed, for the following purposes and under the following conditions:
- (i) *Compliance testing*;
 - (ii) Demonstrations at a trade show provided the notice contained in paragraph (c) of this section is displayed in a conspicuous location on, or immediately adjacent to, the device;
 - (iii) Demonstrations at an exhibition conducted at a business, commercial, industrial, scientific or medical location, but excluding locations in a residential environment, provided the notice contained in paragraphs (c) or (d) of this section, as appropriate, is displayed in a conspicuous location on, or immediately adjacent to, the device;
 - (iv) Evaluation of product performance and determination of customer acceptability, provided such operation takes place at the manufacturer's facilities during developmental, design or pre-production states; or
 - (v) Evaluation of product performance and determination of customer acceptability where customer acceptability of a radio frequency device cannot be determined at the manufacturer's facilities because of size or unique capability of the device, provided the device is operated at a business, commercial, industrial, scientific or medical user's site, but not at a residential site, during the development, design or pre-production stages.
- (e)(2) For the purpose of paragraphs (e)(1)(iv) and (e)(1)(v) of this section, the term *manufacturer's facilities* includes the facilities of the party responsible for compliance with the regulations and the manufacturer's premises, as well as the facilities of other entities working under the authorization of the responsible party in connection with the development and manufacture, but not the marketing, of the equipment.
- (f) For radio frequency devices subject to verification and sold solely to business, commercial, industrial, scientific and medical users (excluding products sold to other parties or for operation in a residential environment), parties responsible for verification of the devices shall have the option of ensuring compliance with the applicable technical specifications of this chapter at each end user's location after installation, provided that the purchase or lease agreement includes a proviso that such a determination of compliance be made and is the responsibility of the party responsible for verification of the equipment.

Certification & User's Manual Information

The following is extracted from Title 47 of the Code of Federal Regulations, Part 2, Subpart J — Equipment Authorization Procedures:

§ 2.901 Basis and Purpose

- (a) In order to carry out its responsibilities under the Communications Act and the various treaties and international regulations, and in order to promote efficient use of the radio spectrum, the Commission has developed technical standards for radio frequency equipment and parts or components thereof. The technical standards applicable to individual types of equipment are found in that part of the rules governing the service wherein the equipment is to be operated.¹ *In addition to the technical standards provided, the rules governing the service may require that such equipment be verified by the manufacturer or importer, be authorized under a Declaration of Conformity, or receive an equipment authorization from the Commission by one of the following procedures: certification or registration.*
- (b) The following sections describe the verification procedure, the procedure for a Declaration of Conformity, and the procedures to be followed in obtaining certification from the Commission and the conditions attendant to such a grant.

§ 2.907 Certification.

- (a) Certification is an equipment authorization issued by the Commission, based on representation and test data submitted by the applicant.
- (b) Certification attaches to all units subsequently marketed by the grantee which are identical (see Section 2.908) to the sample tested except for permissive changes or other variations authorized by the Commission pursuant to Section 2.1043.

¹ In this case, the equipment is subject to the rules of Part 15. More specifically, the equipment falls under Subpart B (of Part 15), which deals with unintentional radiators.

Certification & User's Manual Information

§ 2.948 Description of measurement facilities.

- (a) Each party making measurements of equipment that is subject to an equipment authorization under Part 15 or Part 18 of this chapter, regardless of whether the measurements are filed with the Commission or kept on file by the party responsible for compliance of equipment marketed within the U.S. or its possessions, shall compile a description of the measurement facilities employed.
- (1) If the measured equipment is subject to the verification procedure, the description of the measurement facilities shall be retained by the party responsible for verification of the equipment.
- (i) *If the equipment is verified through measurements performed by an independent laboratory, it is acceptable for the party responsible for verification of the equipment to rely upon the description of the measurement facilities retained by or placed on file with the Commission by that laboratory. In this situation, the party responsible for the verification of the equipment is not required to retain a duplicate copy of the description of the measurement facilities.*
- (ii) If the equipment is verified based on measurements performed at the installation site of the equipment, no specific site calibration data is required. It is acceptable to retain the description of the measurement facilities at the site at which the measurements were performed.
- (2) If the equipment is to be authorized by the Commission under the certification procedure, the description of the measurement facilities shall be filed with the Commission's Laboratory in Columbia, Maryland. The data describing the measurement facilities need only be filed once but must be updated as changes are made to the measurement facilities or as otherwise described in this section. At least every three years, the organization responsible for filing the data with the Commission shall certify that the data on file is current.

Certification & User's Manual Information

Label and User's Manual Information

The following is extracted from Title 47 of the Code of Federal Regulations, Part 15, Subpart A — General:

§ 15.19 Labeling requirements.

(a) *In addition to the requirements in Part 2 of this chapter, a device subject to certification or verification shall be labeled as follows:*

- (1) Receivers associated with the operation of a licensed radio service, e.g., FM broadcast under Part 73 of this chapter, land mobile operation under Part 90, etc., shall bear the following statement in a conspicuous location on the device:

This device complies with Part 15 of the FCC Rules. Operation is subject to the condition that this device does not cause harmful interference.

- (2) A stand-alone cable input selector switch, shall bear the following statement in a conspicuous location on the device:

This device is verified to comply with Part 15 of the FCC Rules for use with cable television service.

- (3) All other devices shall bear the following statement in a conspicuous location on the device:

This device complies with Part 15 of the FCC Rules. Operation is subject to the following two conditions: (1) This device may not cause harmful interference, and (2) this device must accept any interference received, including interference that may cause undesired operation.

- (4) Where a device is constructed in two or more sections connected by wires and marketed together, the statement specified under paragraph (a) of this section is required to be affixed only to the main control unit.

- (5) When the device is so small or for such use that it is not practicable to place the statement specified under paragraph (a) of this section on it, the information required by this paragraph shall be placed in a prominent location in the instruction manual or pamphlet supplied to the user or, alternatively, shall be placed on the container in which the device is marketed. However, the FCC identifier or the unique identifier, as appropriate, must be displayed on the device.

§ 15.21 Information to user.

The users manual or instruction manual for an intentional or unintentional radiator shall caution the user that changes or modifications not expressly approved by the party responsible for compliance could void the user's authority to operate the equipment.

Verification & User's Manual Information

The following is extracted from Title 47 of the Code of Federal Regulations, Part 15, Subpart B — Unintentional Radiators:

§ 15.105 Information to the user.

- (a) For a Class A digital device or peripheral, the instructions furnished the user shall include the following or similar statement, placed in a prominent location in the text of the manual:

Note: This equipment has been tested and found to comply with the limits for a Class A digital device, pursuant to Part 15 of the FCC Rules. These limits are designed to provide reasonable protection against harmful interference when the equipment is operated in a commercial environment. This equipment generates, uses, and can radiate radio frequency energy and, if not installed and used in accordance with the instruction manual, may cause harmful interference to radio communications. Operation of this equipment in a residential area is likely to cause harmful interference in which case the user will be required to correct the interference at own expense.

- (b) For a Class B digital device or peripheral, the instructions furnished the user shall include the following or similar statement, placed in a prominent location in the text of the manual:

Note: This equipment has been tested and found to comply with the limits for a Class B digital device, pursuant to Part 15 of the FCC Rules. These limits are designed to provide reasonable protection against harmful interference when the equipment is operated in a residential environment. This equipment generates, uses, and can radiate radio frequency energy and, if not installed and used in accordance with the instruction manual, may cause harmful interference to radio communications. However, there is no guarantee that interference will not occur in a particular installation. If this equipment does cause harmful interference to radio or television reception, which can be determined by turning the equipment off and on, the user is encouraged to try to correct the interference by one or more of the following measures:

- Reorient or relocate the receiving antenna.
- Increase the separation between the equipment and receiver.
- Connect the equipment into an outlet on a circuit different from that to which the receiver is connected.
- Consult the dealer or an experienced radio/TV technician for help.

End of Report