

Serena 4-Group RF Remote Control

Model CS-YJ-4GC-WH • For Serena® Powered Window Shades • Setup Guide—Please Read Before Operating

Device Description

The Serena® 4-Group RF handheld remote control provides remote shade operation from the palm of your hand. The radio frequency enabled control transmits signals to compatible Lutron® shades and shading systems. To access advanced features, please refer to the installation and operation instructions for the Lutron device(s) under control.

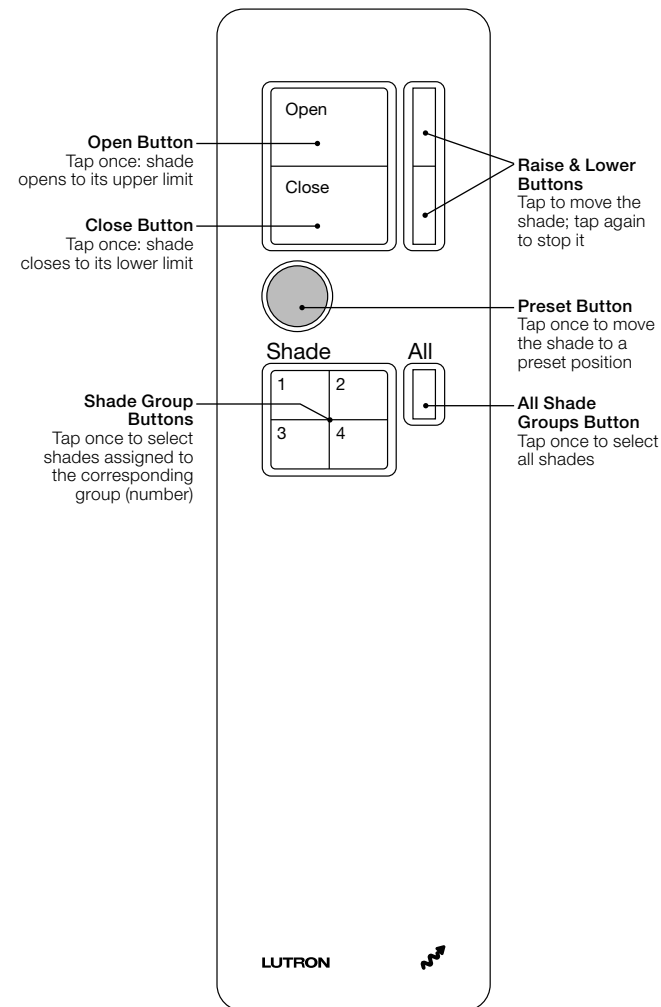

Battery Replacement

The Serena® 4-Group RF handheld remote control uses 2 AAA alkaline batteries which are pre-installed (see diagram). DO NOT use NiCad or rechargeable batteries.

To replace batteries:

- Remove the battery cover.
- Replace with 2 size AAA alkaline batteries as shown.
- Replace the battery cover.

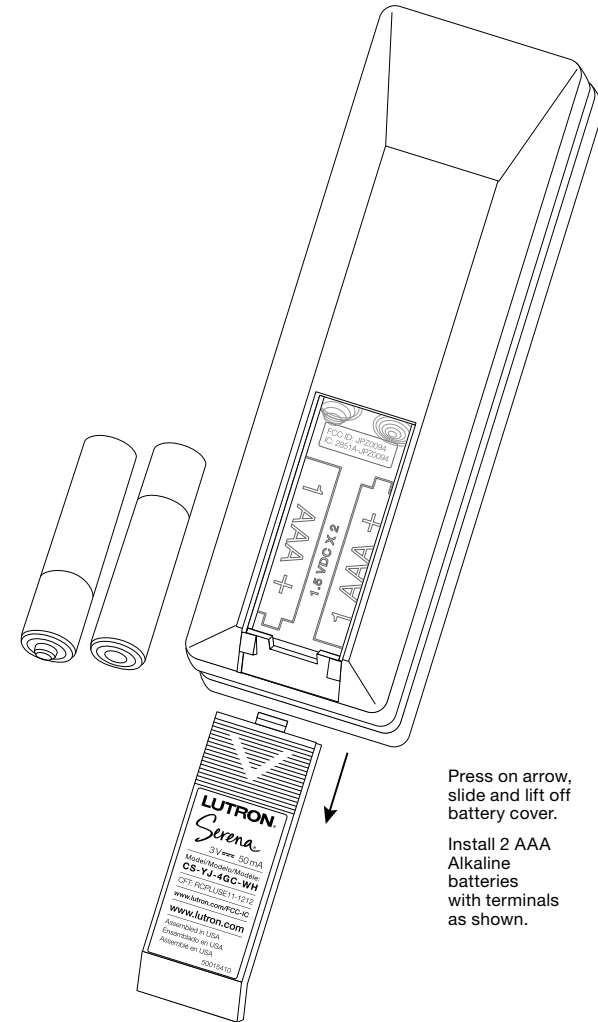

The Serena® 4-Group RF remote control is safe for use around baths and spas.
NOTICE: DO NOT submerge in water.

Troubleshooting

Symptom	Probable Cause and Action
Buttons don't light up when they are pressed.	Dead, low, or no battery in wireless control. • Install new battery. Battery is installed incorrectly (reversed polarity). • Install battery as indicated in the Battery Replacement section.
A specific window treatment does not respond when a button is pressed.	The window treatment is not assigned to the control. Devices are out of range. • Check to make sure all remote controls, keypads, dimmers, switches and shades/ draperies are within 30 ft (9 m) of each other.

Limited Warranty

Lutron will, at its option, repair or replace any unit that is defective in materials or manufacture within one year after purchase. For warranty service, return unit to place of purchase or mail to Lutron at 7200 Suter Rd, Coopersburg, PA 18036-1299, postage pre-paid.

This warranty is in lieu of all other express warranties, and the implied warranty of merchantability is limited to one year from purchase. This warranty does not cover the cost of installation, removal, or reinstallation, or damage resulting from misuse, abuse, or damage from improper wiring or installation. This warranty does not cover incidental or consequential damages.

LUTRON'S LIABILITY ON ANY CLAIM FOR DAMAGES ARISING OUT OF OR IN CONNECTION WITH THE MANUFACTURE, SALE, INSTALLATION, DELIVERY, OR USE OF THE UNIT SHALL NEVER EXCEED THE PURCHASE PRICE OF THE UNIT.

This warranty gives you specific legal rights, and you may have other rights which vary from state to state. Some states do not allow the exclusion or limitation of incidental or consequential damages, or limitation on how long an implied warranty may last, so the above limitations may not apply to you.

These products may be covered under the following U.S. patents/ DES 391,924; and corresponding foreign patents.

Lutron, the Sunburst logo, Maestro IR, GRAFIK Eye, Sivoia, Sivoia QED, and Spacer System are registered trademarks of Lutron Electronics Co., Inc.

©2011 Lutron Electronics Co., Inc.

For Assistance:

WORLD HEADQUARTERS

Lutron Electronics Co., Inc.
7200 Suter Road
Coopersburg, PA 18036
United States
Tel: +1.610.282.3800
Fax: +1.610.282.1243

ASIAN HEADQUARTERS

Lutron GL Ltd.
15 Hoe Chiang Road
#07-03 Tower Fifteen
Singapore 089316
Tel: +65.6220.4666
Fax: +65.6220.4333
lutronsea@lutron.com

Spain-Madrid

Tel: +34.91.567.84.79
Fax: +34.91.567.84.79
FREEPHONE
900.948.944

Spain-Barcelona

Tel: +34.93.496.57.42
Fax: +34.93.496.57.50
FREEPHONE
0900.948.944

EUROPEAN HEADQUARTERS

Lutron EA Ltd.
6 Sovereign Close
London, E1W 3JF
United Kingdom
Tel: +44.(0)20.7702.0657
Fax: +44.(0)20.7480.6899

ADDITIONAL LUTRON SALES OFFICES:

Germany
Tel: +49.309.710.4590
Fax: +49.309.710.4591
FREEPHONE
00800.5887.6635

Hong Kong

Tel: +852.2104.7733
Fax: +852.2104.7633

Beijing

Tel: +86.10.5877.1817
Fax: +86.10.5877.1816

Shanghai

Tel: +86.21.6288.1473
Fax: +86.21.6288.1751

CUSTOMER SERVICE/ORDERING

USA: +1.610.282.3800
08.00 - 20.00 EST
UK: +44-(0)20.7702.0657
09.00 - 18.00 GMT

France

Lutron LTC, S.A.R.L.
90 rue de Villiers
92300 Levallois-Perret,
France
Tel: +33-(0)1.41.05.42.80
Fax: +33-(0)1.41.05.01.80
FREEPHONE:
0800.90.12.18
lutronfrance@lutron.com

Singapore

Tel: +65.6220.4666
Fax: +65.6220.4333

Japan

Tel: +81.3.5575.8411
Fax: +81.3.5575.8420

INTERNET:

www.lutron.com
shadinginfo@lutron.com