



Zacta

TEST REPORT

Report number : Z071C-13393

Issue date : October 25, 2013

The device, as described herewith, was tested pursuant to applicable test procedure and complies with the requirements of;

FCC Part15 Subpart C

The test results are traceable to the international or national standards.

Applicant	: KYOCERA Corporation
Equipment under test (EUT)	: Mobile Phone
Model number	: KYY08
FCC ID	: JOYKYY08

Date of test : October 7,8,15-17, 2013
 Test place : TÜV SÜD Zacta Ltd. Yonezawa Testing Center
 4149-7 Hachimanpara 5-chome
 Yonezawa-shi Yamagata 992-1128 Japan
 Phone: +81-238-28-2880 Fax: +81-238-28-2888
 Test results : Complied

The results in this report are applicable only to the equipment tested.
 This report shall not be re-produced except in full without the written approval of TÜV SÜD Zacta Ltd.
 This test report must not be used by client to claim product certification, approval, or endorsement by NVLAP, NIST, or any agency of the federal government.

Tested by : Chiaki Kanno
 Chiaki Kanno

Authorized by : Eiji Akiba
 Eiji Akiba
 Deputy General Manager of EMC Technical Department

NVLAP[®]
 NVLAP LAB CODE 200306-0



Table of contents

	Page
1. Summary of Test	4
1.1 Purpose of test	4
1.2 Standards	4
1.3 List of applied test to the EUT	4
1.4 Modification to the EUT by laboratory	4
2. Equipment Under Test	5
2.1 General Description of equipment	5
2.2 EUT information	5
2.3 Variation of the family model(s)	6
2.4 Operating channels and frequencies	6
2.5 Description of Test mode	7
2.6 Operating mode	7
3. Configuration of equipment	8
3.1 Equipment(s) used	8
3.2 Cable(s) used	8
3.3 System configuration	9
4. 20dB Bandwidth	10
4.1 Measurement procedure	10
4.2 Limit	10
4.3 Measurement result	10
4.4 Trace data	11
5. Carrier Frequency Separation	13
5.1 Measurement procedure	13
5.2 Limit	13
5.3 Measurement result	13
5.4 Trace data	14
6. Number of Hopping Frequencies	15
6.1 Measurement procedure	15
6.2 Limit	15
6.3 Measurement result	15
6.4 Trace data	16
7. Time of Occupancy (Dwell Time)	18
7.1 Measurement procedure	18
7.2 Limit	18
7.3 Measurement result	18
7.4 Trace data	19
8. Maximum Peak Output Power	21
8.1 Measurement procedure	21
8.2 Limit	21
8.3 Measurement result	21
8.4 Trace data	22
9. Band Edge Compliance of RF Conducted Emissions	24
9.1 Measurement procedure	24



Zacta

9.2 Limit.....	24
9.3 Measurement result.....	24
9.4 Trace data	26
10. Spurious emissions - Conducted -	28
10.1 Measurement procedure.....	28
10.2 Limit.....	28
10.3 Measurement result.....	28
10.4 Trace data	29
11. Spurious Emissions - Radiated -.....	35
11.1 Measurement procedure	35
11.2 Calculation method.....	36
11.3 Limit.....	36
11.4 Test data.....	37
12. Restricted Band of Operation.....	39
12.1 Measurement procedure.....	39
12.2 Limit.....	39
12.3 Measurement Result.....	39
12.4 Test data.....	40
13. AC Power Line Conducted Emissions.....	44
13.1 Measurement procedure.....	44
13.2 Calculation method.....	44
13.3 Limit.....	44
13.4 Test data.....	45
14. Antenna requirement	46
15. Uncertainty of measurement.....	47
16. Laboratory description	48
Appendix A. Test equipment	49



Zacta

1. Summary of Test

1.1 Purpose of test

It is the original test in order to verify conformance to FCC Part 15 Subpart C.

1.2 Standards

CFR47 FCC Part 15 Subpart C

1.2.1 Test Methods

ANSI C63.4-2009

1.2.2 Deviation from standards

None

1.3 List of applied test to the EUT

Test items Section	Test items	Condition	Result
15.247(a)(1)	20dB Bandwidth	Conducted	PASS
15.247(a)(1)	Carrier Frequency Separation	Conducted	PASS
15.247(a)(1)(iii)	Number of Hopping Frequencies	Conducted	PASS
15.247(a)(1)(iii)	Time of Occupancy (Dwell Time)	Conducted	PASS
15.247(b)(3)	Maximum Peak Output Power	Conducted	PASS
15.247(d)	Band Edge Compliance of RF Conducted Emissions	Conducted	PASS
15.247(d) 15.205 15.209	Spurious Emissions	Conducted Radiated	PASS
15.247(d) 15.205 15.209	Restricted Bands of Operation	Radiated	PASS
15.207	AC Power Line Conducted Emissions	Conducted	PASS

1.3.1 Test set up

Table-Top

1.4 Modification to the EUT by laboratory

None



Zacta

2. Equipment Under Test

2.1 General Description of equipment

EUT is the Mobile Phone.

2.2 EUT information

Applicant	:	KYOCERA Corporation Yokohama Office 2-1-1 Kagahara, Tsuzuki-ku, Yokohama-shi, Kanagawa, Japan Phone: +81-45-943-6253 Fax: +81-45-943-6314
Equipment under test	:	Mobile Phone
Trade name	:	Kyocera
Model number	:	KYY08
Serial number	:	N/A
EUT condition	:	Pre-Production
Max. frequency	:	1GHz
Power ratings	:	Battery: DC 3.7 V
Size	:	(W) 49 × (D) 16.5 × (H) 112 mm
Environment	:	Indoor and Outdoor use
Terminal limitation	:	-20°C to 60°C
RF Specification Protocol	:	Bluetooth 2.1 + EDR
Frequency range	:	2402MHz-2480MHz
Number of RF Channels	:	79 Channels
Modulation type/ Data rate	:	FHSS: GFSK (1Mbps), π/4-DQPSK (2Mbps), 8-DPSK (3Mbps)
Channel separation	:	1MHz
Output power	:	6.934mW (DH5) 5.808mW (3-DH5)
Antenna type	:	Internal antenna
Antenna gain	:	0dBi

2.3 Variation of the family model(s)

Not applicable

2.4 Operating channels and frequencies

Channel	Frequency [MHz]	Channel	Frequency [MHz]	Channel	Frequency [MHz]
0	2402	27	2429	54	2456
1	2403	28	2430	55	2457
2	2404	29	2431	56	2458
3	2405	30	2432	57	2459
4	2406	31	2433	58	2460
5	2407	32	2434	59	2461
6	2408	33	2435	60	2462
7	2409	34	2436	61	2463
8	2410	35	2437	62	2464
9	2411	36	2438	63	2465
10	2412	37	2439	64	2466
11	2413	38	2440	65	2467
12	2414	39	2441	66	2468
13	2415	40	2442	67	2469
14	2416	41	2443	68	2470
15	2417	42	2444	69	2471
16	2418	43	2445	70	2472
17	2419	44	2446	71	2473
18	2420	45	2447	72	2474
19	2421	46	2448	73	2475
20	2422	47	2449	74	2476
21	2423	48	2450	75	2477
22	2424	49	2451	76	2478
23	2425	50	2452	77	2479
24	2426	51	2453	78	2480
25	2427	52	2454		
26	2428	53	2455		

2.5 Description of Test mode

The EUT had been tested under operating condition.
There are three channels have been tested as following:

Tested Channel	Frequency [MHz]
Low	2402
Middle	2441
High	2480

The pre-test has been conducted to determine the worst-case mode from all possible combinations between available modulations, data rates.

Tested Channel	Modulation Technology	Modulation Type	Packet Type
Low, Middle, High	FHSS	GFSK	DH5
Low, Middle, High	FHSS	8-DPSK	3-DH5

The field strength of spurious emissions was measured at each position of all three axis X, Y and Z to compare the level, and the maximum noise.
The worst emission was found in Z axis and the worst case recorded.

2.6 Operating mode

[Tx mode]

- i) Bluetooth test program setup to the DM tool
- ii) Select a test mode
 - Operating frequency:
 - No hopping (Channel Low: 2402MHz, Channel Middle: 2441MHz, Channel High: 2480MHz)
 - Hopping
 - Packet type: DH5, 3-DH5
- iii) Start test mode

[Rx mode]

- i) Bluetooth test program setup to the DM tool
- ii) Select a test mode
 - Operating frequency: Channel Low: 2402MHz, Channel Middle: 2441MHz, Channel High: 2480MHz
- iii) Start test mode



3. Configuration of equipment

3.1 Equipment(s) used

No.	Equipment	Company	Model No.	Serial No.	FCC ID / DoC	Comment
1	Mobile Phone	KYOCERA	KYY08	N/A	JOYKYY08	EUT
2	AC Adapter	KDDI	0203PQA	HT-VLA	-	*
3	Personal Computer	FUJITSU	FMVNC4DC3	CP27202	DoC	-
4	AC Adapter for PC	FUJITSU	ADP-602HA	CP281868-01	-	-

*: AC power line Conducted Emission Test.

3.2 Cable(s) used

No.	Cable	Length[m]	Shield	Connector	Comment
a	USB cable	0.9	Yes	Metal	-
b	USB cable	2.0	Yes	Metal	-
c	DC cable	1.9	No	Plastic	-
d	AC power cord for PC AC Adapter	2.0	No	Plastic	-

3.3 System configuration

[Radiated Emission and Antenna port Conducted Test]

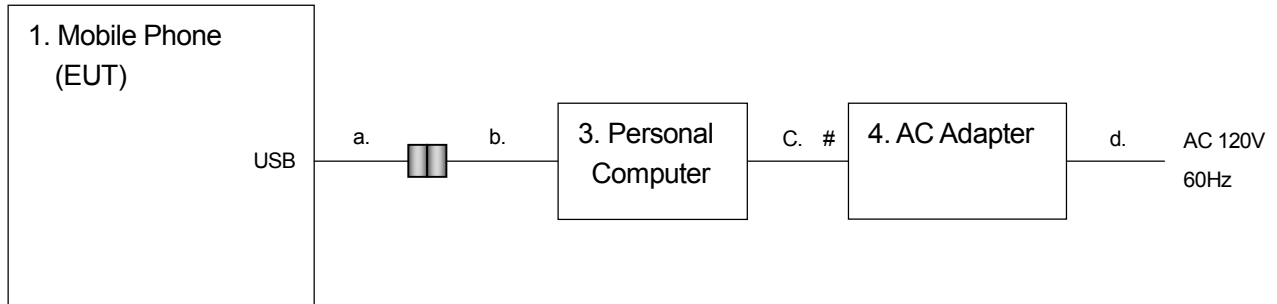



 : Connector

: Un-detachable cable

Note: Numbers assigned to equipment or cables on this diagram correspond to the list in “3.1 Equipment(s) used” and “3.2 Cable(s) used”.

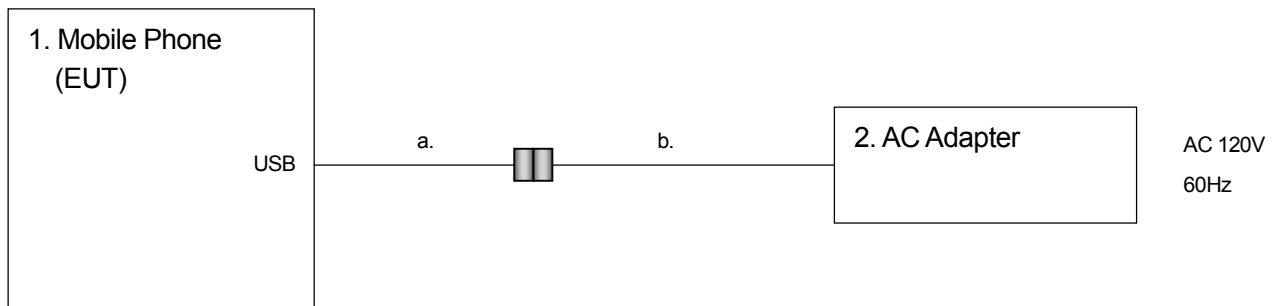
[AC Power Line Conducted Emission Test]



 : Connector

Note: Numbers assigned to equipment or cables on this diagram correspond to the list in “3.1 Equipment(s) used” and “3.2 Cable(s) used”.

4. 20dB Bandwidth

4.1 Measurement procedure [FCC 15.247(a)(1)]

The bandwidth at 20dB down from the highest inband spectral density is measured with a spectrum analyzer connected to the antenna terminal, while EUT is operating in transmission mode at the appropriate center frequency.

The spectrum analyzer is set to;

- RBW=30kHz, VBW=100kHz, Span=3MHz, Sweep=auto, Detector=Peak, Trace mode=Max hold

The EUT was set to operate with following conditions.

- No hopping [Channel Low: 2402MHz, Channel Middle: 2441MHz, Channel High: 2480MHz]

The test mode of EUT is as follows.

- Tx mode

- Test configuration

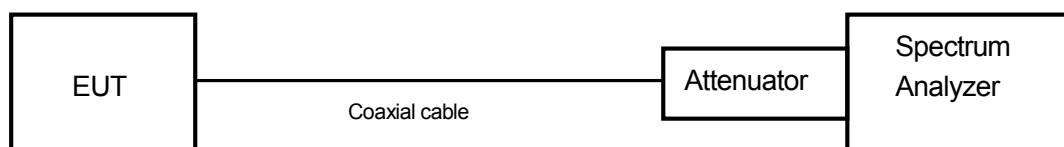

4.2 Limit

None

4.3 Measurement result

Date : Oct. 7, 2013
 Temperature : 26.0 [°C]
 Humidity : 58.0 [%]
 Test place : Shielded room

Test personnel :

Tested by :

Chiaki Kanno

Channel	Frequency [MHz]	20dB bandwidth [MHz]	
		DH5	3-DH5
Low	2402	1.001	1.293
Middle	2441	0.965	1.291
High	2480	0.968	1.292



Zacta

4.4 Trace data
[DH5]

Channel Low

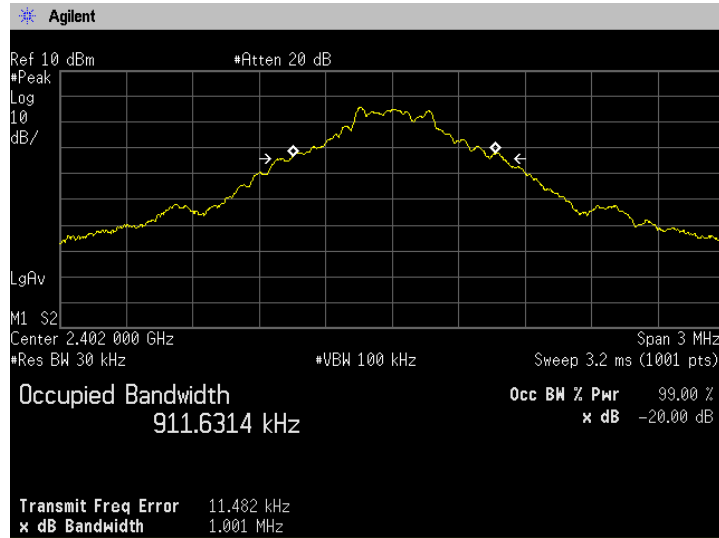

Channel Middle

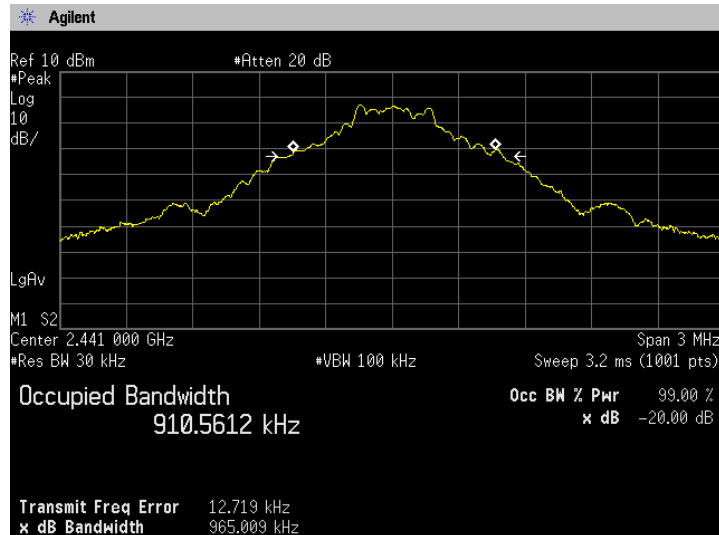

Channel High

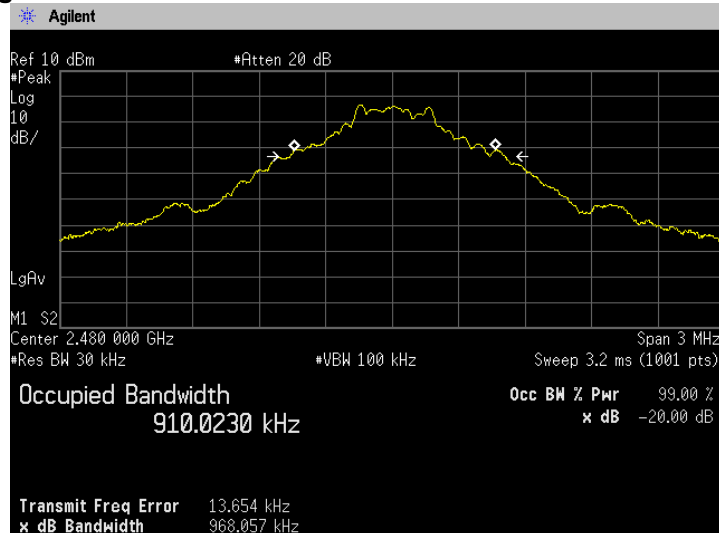



Zacta

[3-DH5]

Channel Low

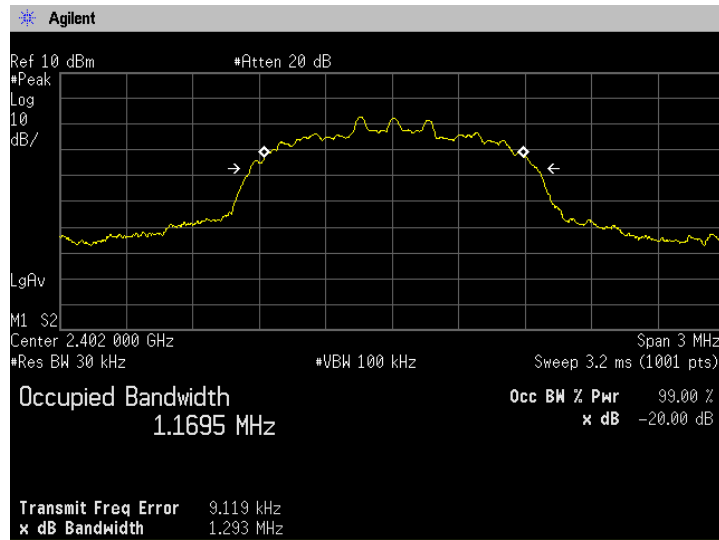

Channel Middle

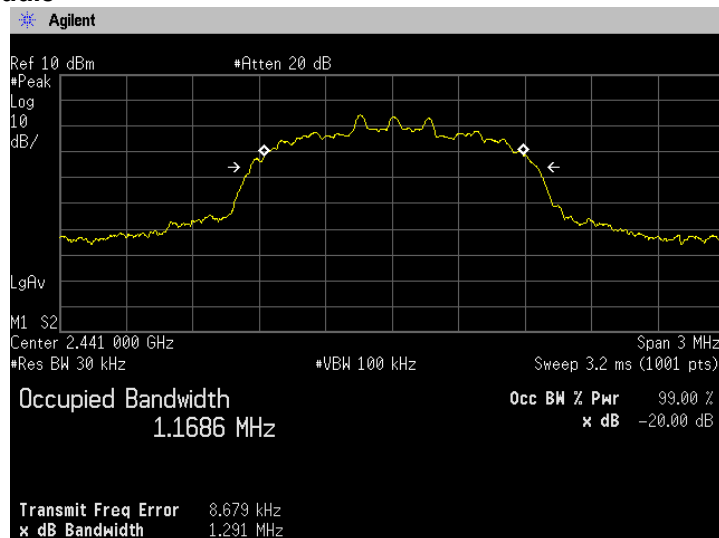

Channel High

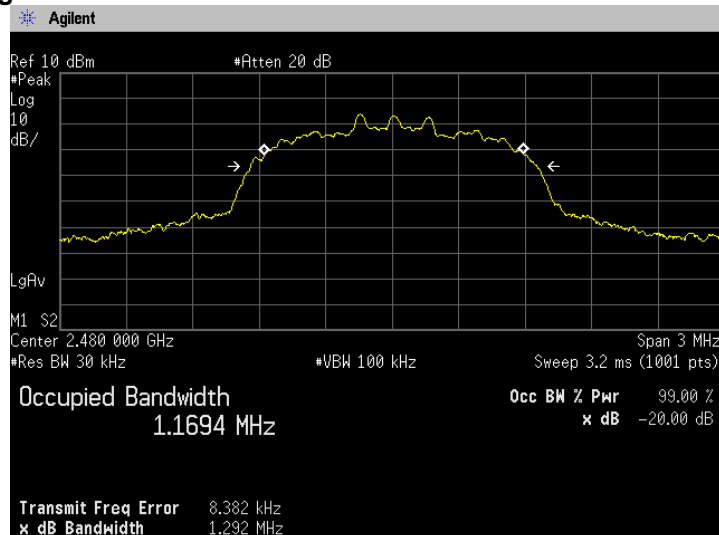

5. Carrier Frequency Separation

5.1 Measurement procedure

[FCC 15.247(a)(1)]

The adjacent channel interval is measured with a spectrum analyzer connected to the antenna terminal, while EUT is operating in transmission mode at the appropriate center frequency.

The spectrum analyzer is set to;

- RBW=30kHz, VBW=30kHz, Span=3MHz, Sweep=auto, Detector=Peak, Trace mode=Max hold

The EUT was set to operate with following conditions.

- Hopping [Channel Middle: 2441MHz]

The test mode of EUT is as follows.

- Tx mode

- Test configuration

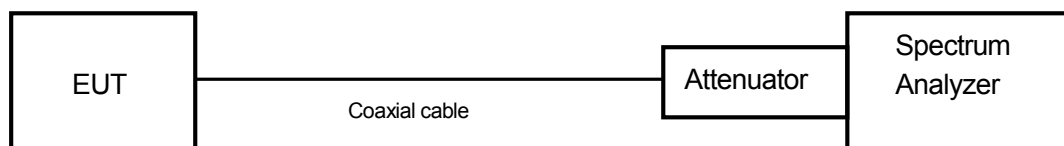

5.2 Limit

System shall have hopping channel carrier frequencies separated by a minimum of, 25kHz or two-thirds of the 20dB bandwidth of the hopping channel, whichever is greater.

5.3 Measurement result

Date : Oct. 7, 2013
 Temperature : 26.0 [°C]
 Humidity : 58.0 [%]
 Test place : Shielded room

Test personnel :

Tested by :

Chiaki Kanno

Packet type	Channel separation [MHz]	Limit [MHz]	Result
DH5	1.017	>two-thirds of the 20dB Bandwidth =667kHz	PASS
3-DH5	1.020	>two-thirds of the 20dB Bandwidth =862kHz	PASS



Zacta

5.4 Trace data [DH5]

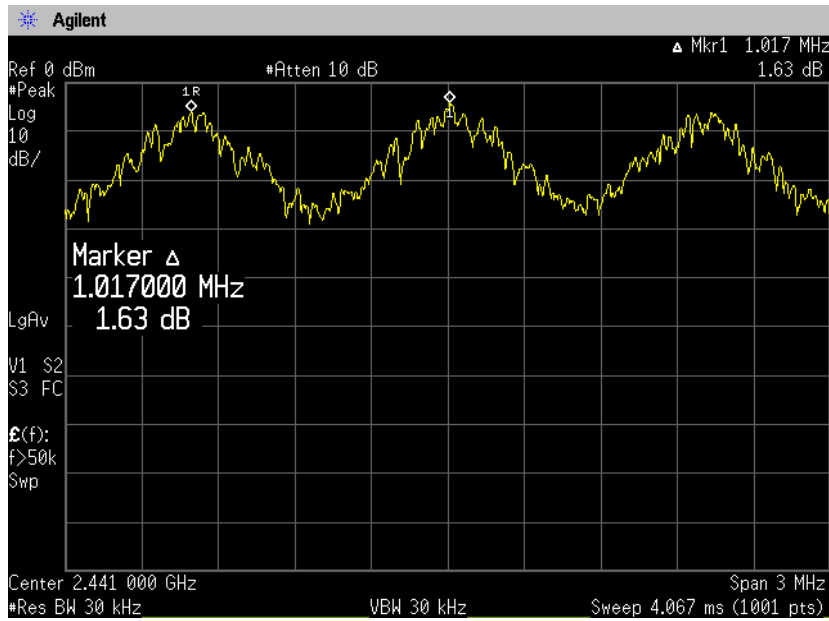

[3-DH5]

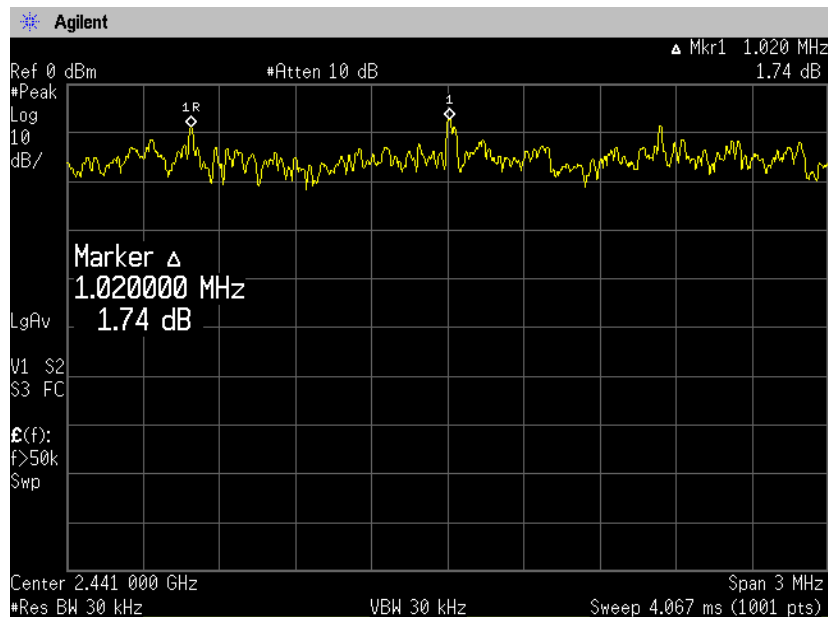

6. Number of Hopping Frequencies

6.1 Measurement procedure

[FCC 15.247(a)(1)(iii)]

The number of hopping channels is measured with a spectrum analyzer connected to the antenna terminal, while EUT is operating in transmission mode at the appropriate center frequency.

The spectrum analyzer is set to;

- RBW=510kHz, VBW=510kHz, Span=Arbitrary setting, Sweep=auto, Detector=Peak,
Trace mode=Max hold

The EUT was set to operate with following conditions.

- Hopping

The test mode of EUT is as follows.

- Tx mode

- Test configuration

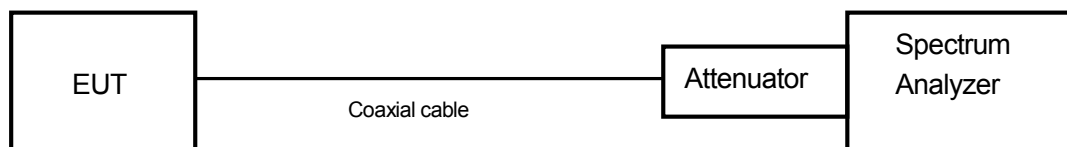

6.2 Limit

Shall have more than 15 channels.

6.3 Measurement result

Date : Oct. 7, 2013
 Temperature : 26.0 [°C]
 Humidity : 58.0 [%]
 Test place : Shielded room

Test personnel :

Tested by :

Chiaki Kanno

Number of channels	Limit	Result
79	≥15 channel	PASS



Zacta

6.4 Trace data [DH5]

Low

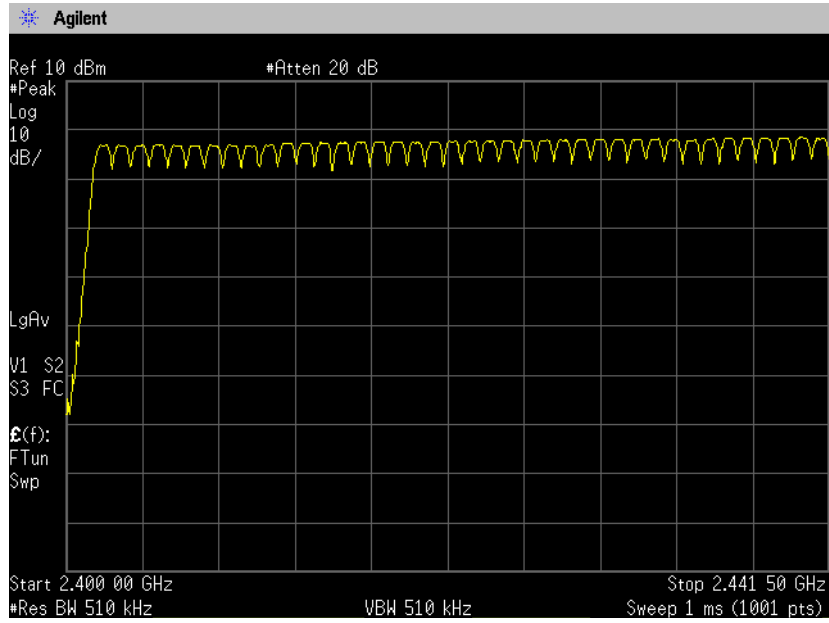

High

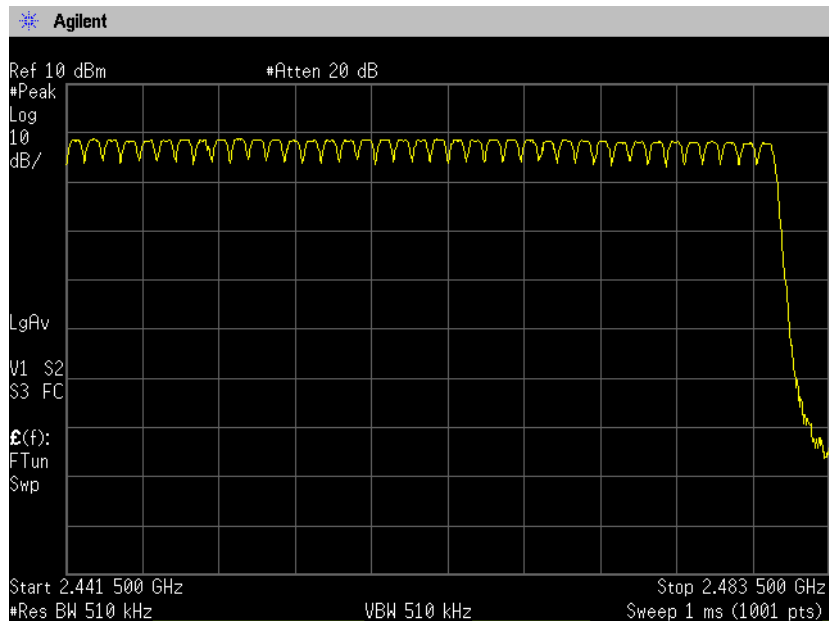



Zacta

[3-DH5]

Low

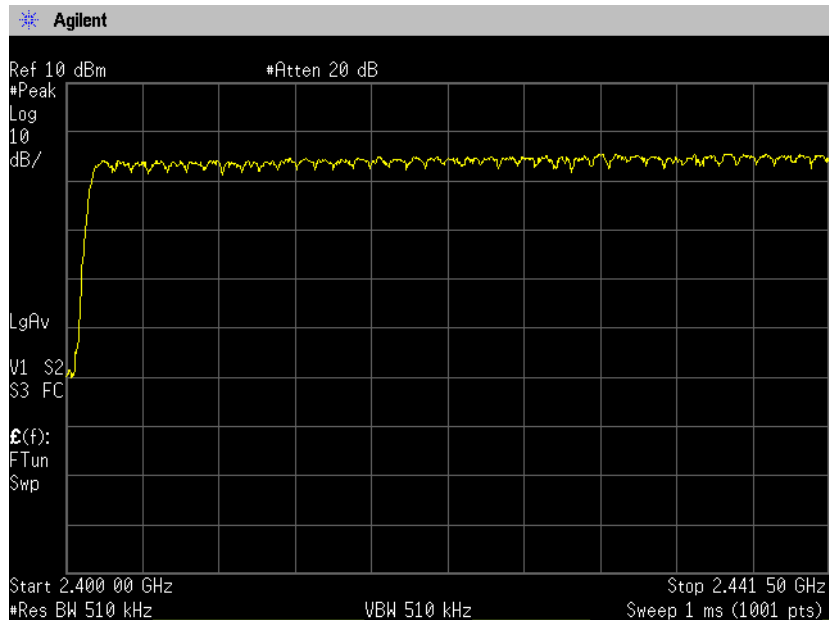

High

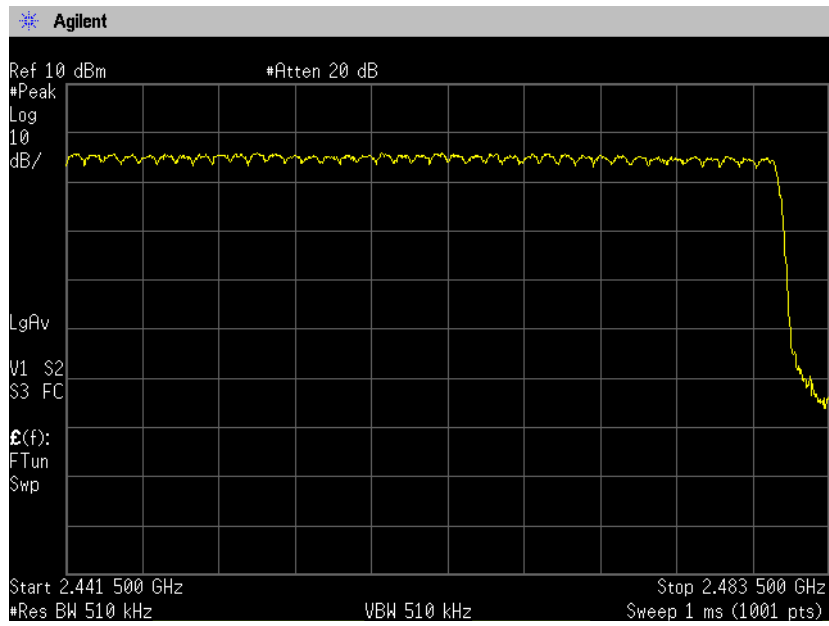

7. Time of Occupancy (Dwell Time)

7.1 Measurement procedure [FCC 15.247(a)(1)(iii)]

The time occupancy of hopping channel is measured with a spectrum analyzer connected to the antenna terminal, while EUT is operating in transmission mode at the appropriate center frequency.

The spectrum analyzer is set to;

- RBW=1MHz, VBW=1MHz, Span=0Hz, Sweep=5ms, Detector=Peak, Trace mode=Single

The EUT was set to operate with following conditions.

- Hopping

The test mode of EUT is as follows.

- Tx mode

- Test configuration

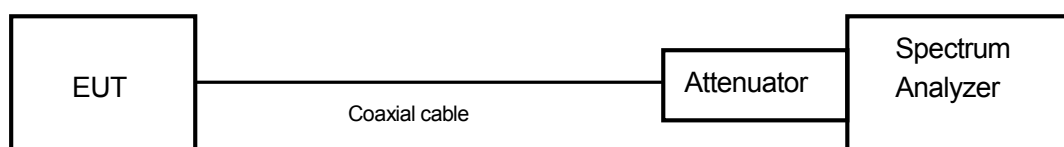

7.2 Limit

The average time of occupancy on any channel shall not be greater than 0.4 seconds within a period of 0.4 seconds multiplied by the number of hopping channels employed.

7.3 Measurement result

Date : Oct. 7, 2013
 Temperature : 26.0 [°C]
 Humidity : 58.0 [%]
 Test place : Shielded room

Test personnel :

Tested by :

Chiaki kanno

Channel	Frequency (MHz)	Packet type	Dwell time (ms)	Occupancy time of 31.6 seconds (s)	Limit	Result
Low	2402	DH5	2.895	0.309	<0.4s	PASS
		3-DH5	2.900	0.309	<0.4s	PASS
Middle	2441	DH5	2.895	0.309	<0.4s	PASS
		3-DH5	2.900	0.309	<0.4s	PASS
High	2480	DH5	2.895	0.309	<0.4s	PASS
		3-DH5	2.900	0.309	<0.4s	PASS

$DH5/3-DH5 = \text{Dwell time (ms)} \times 1600 / 6 / 79 \times 31.6$

The hopping rates of Bluetooth devices change with different types of payload. The longer the payload is, the slower the hopping rate. The hopping rate scenario is defined in Bluetooth core specification.

Calculation:

Occupancy time of 31.6 seconds* = time domain slot length x hop rate / number of hopper channel / 79 / x 31.6

Ex.) for Channel Middle, DH5 = 2.890ms x 1600 / 6 / 79 x 31.6 = 308ms



Zacta

7.4 Trace data [DH5]

Channel Low

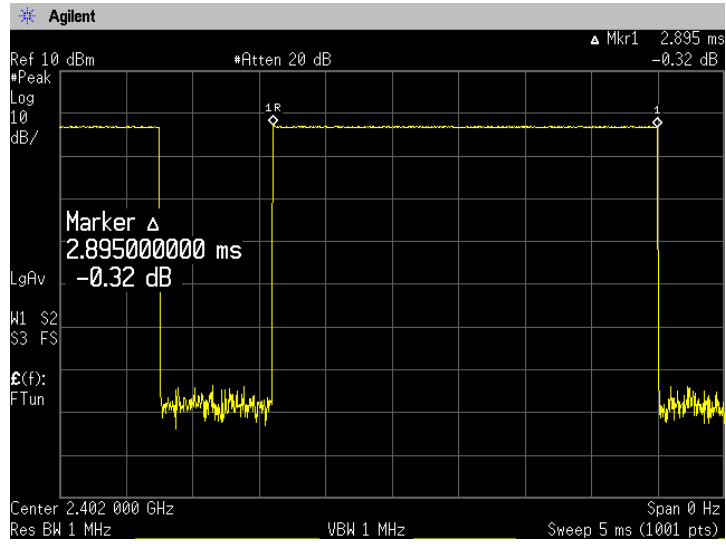

Channel Middle

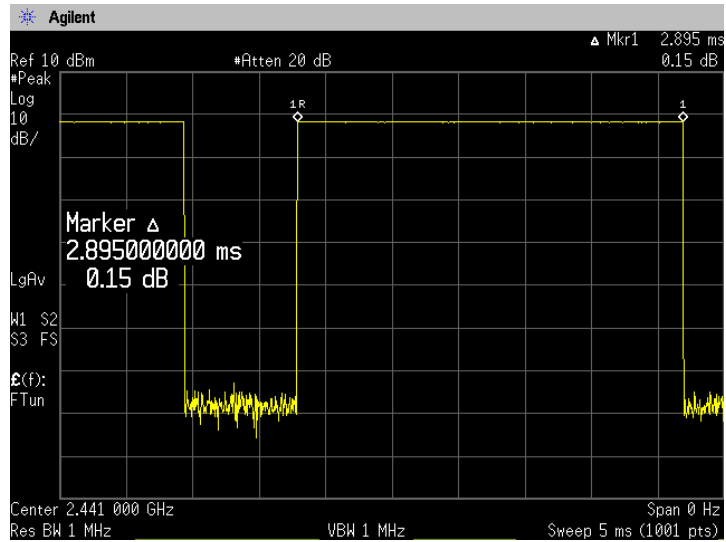

Channel High

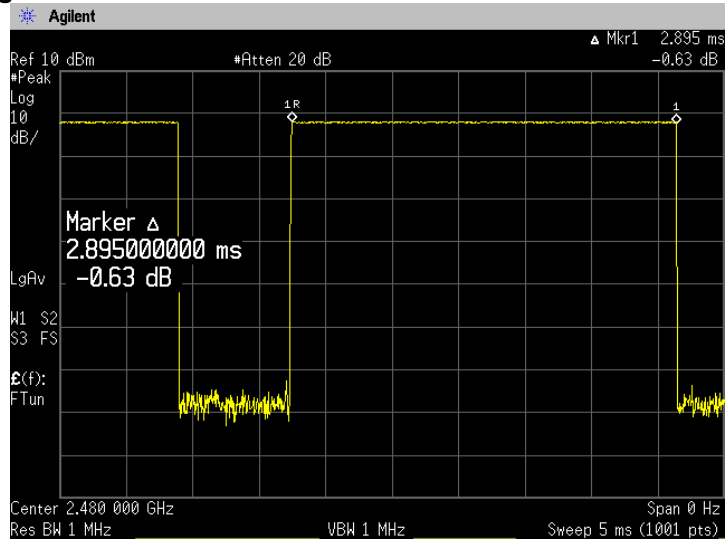

[3-DH5]

Channel Low

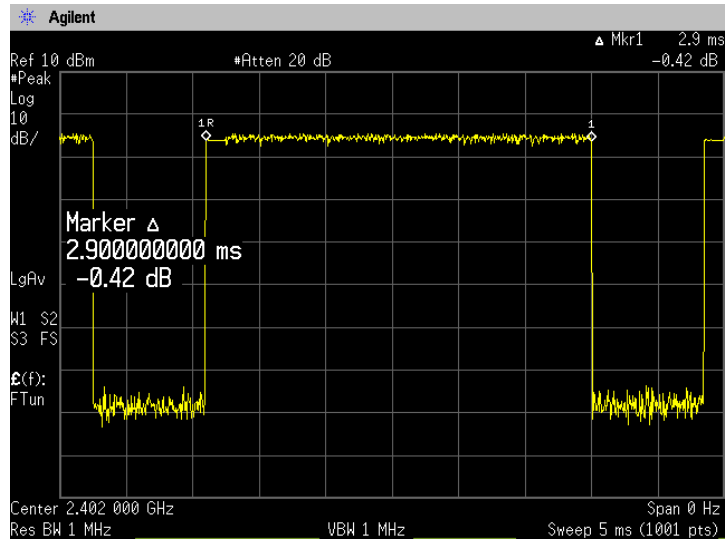

Channel Middle

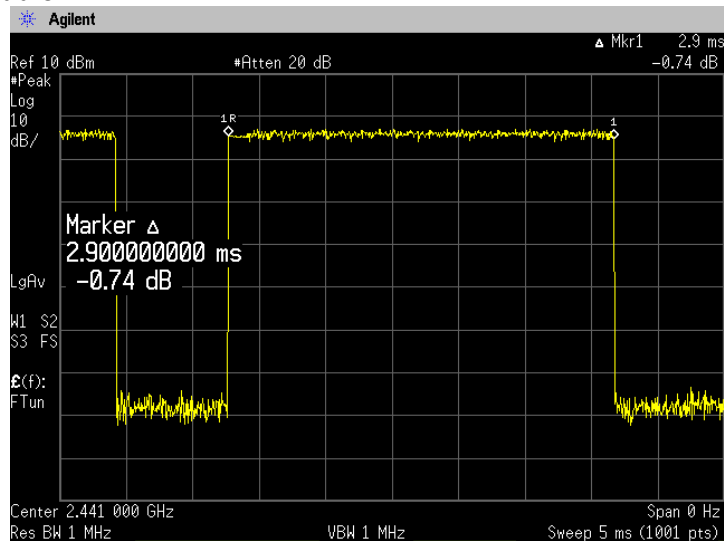

Channel High

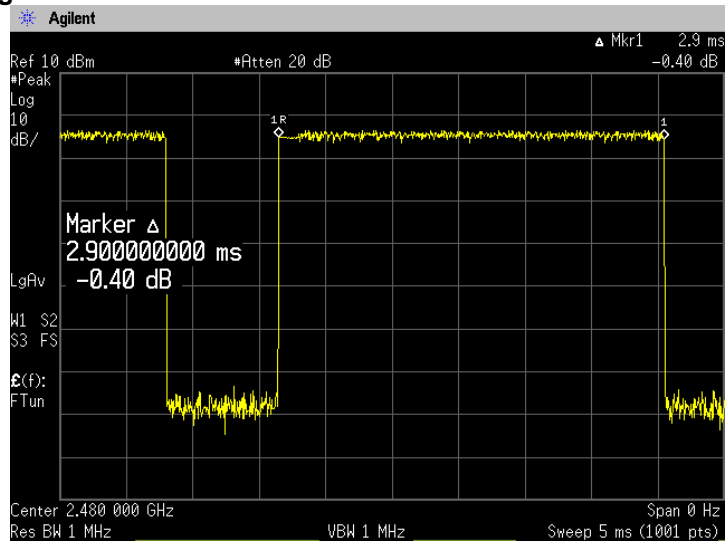

8. Maximum Peak Output Power

8.1 Measurement procedure [FCC 15.247(b)(3), 15.31(e)]

The peak power is measured with a spectrum analyzer connected to the antenna terminal, while EUT is operating in transmission mode at the appropriate center frequency.

The spectrum analyzer is set to;

- RBW=3MHz, VBW=3MHz, Span=10MHz, Sweep=auto, Detector=Peak, Trace mode=Max hold

The EUT was set to operate with following conditions.

- No hopping [Channel Low: 2402MHz, Channel Middle: 2441MHz, Channel High: 2480MHz]

The test mode of EUT is as follows.

- Tx mode

- Test configuration

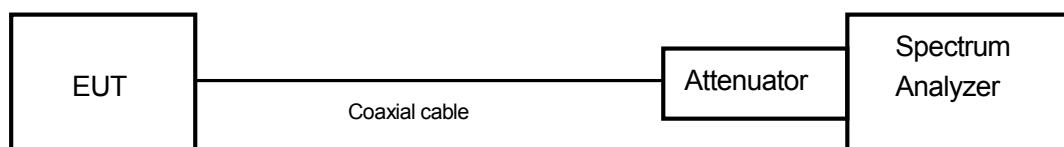

8.2 Limit

0.125 W or less

8.3 Measurement result

Date : Oct. 8, 2013
 Temperature : 24.0 [°C]
 Humidity : 64.0 [%]
 Test place : Shielded room

Test personnel :

Tested by :

Chiaki kanno

Channel	Frequency (MHz)	Packet type	Reading (dBm)	Factor (dB)	Level (dBm)	Peak Output Power (mW)	Limit (mW)	Result
Low	2402	DH5	-2.82	9.87	7.05	5.070	≤125	PASS
		3-DH5	-3.74	9.87	6.13	4.102	≤125	PASS
Middle	2441	DH5	-1.46	9.87	8.41	6.934	≤125	PASS
		3-DH5	-2.23	9.87	7.64	5.808	≤125	PASS
High	2480	DH5	-1.84	9.87	8.03	6.353	≤125	PASS
		3-DH5	-2.62	9.87	7.25	5.309	≤125	PASS

Calculation;

$$\text{Reading (dBm)} + \text{Factor (dB)} = \text{Level (dBm)}$$

$$10 \log P = \text{Level (dBm)}$$

$$P = 10^{(\text{Maximum Peak Output Power} / 10)} \text{ (mW)}$$



Zacta

8.4 Trace data [DH5]

Channel Low

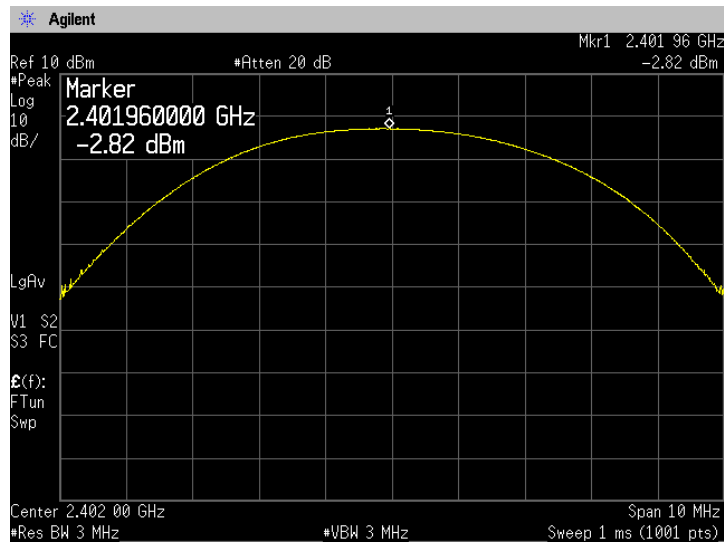

Channel Middle

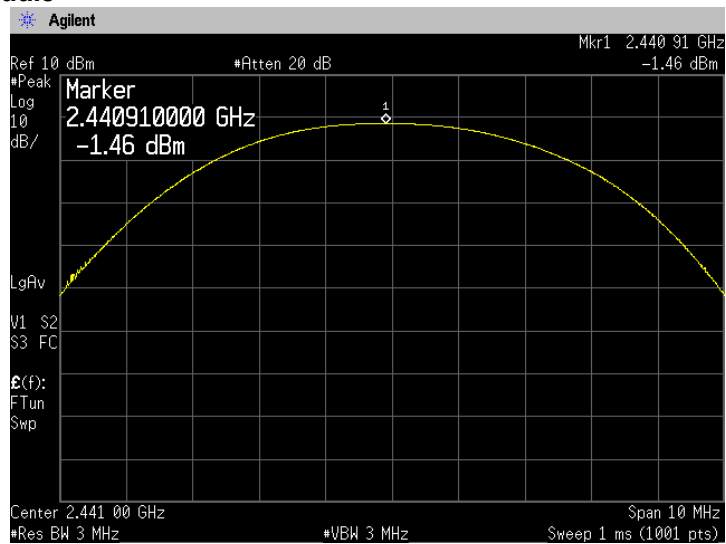

Channel High

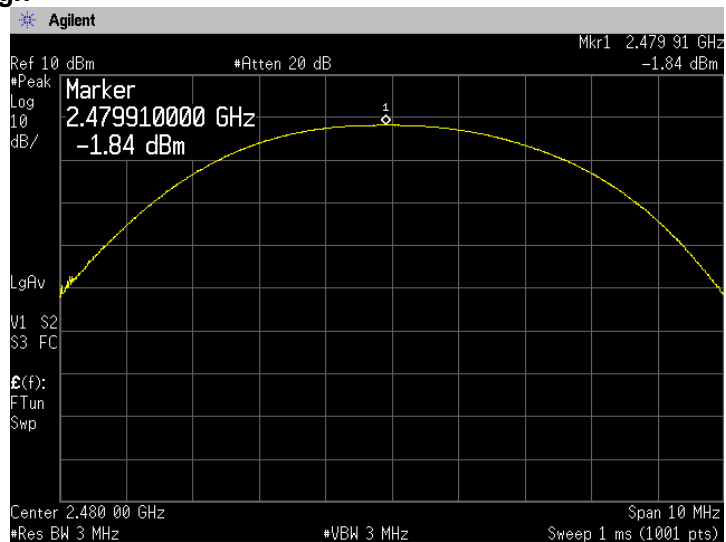



Zacta

[3-DH5]

Channel Low

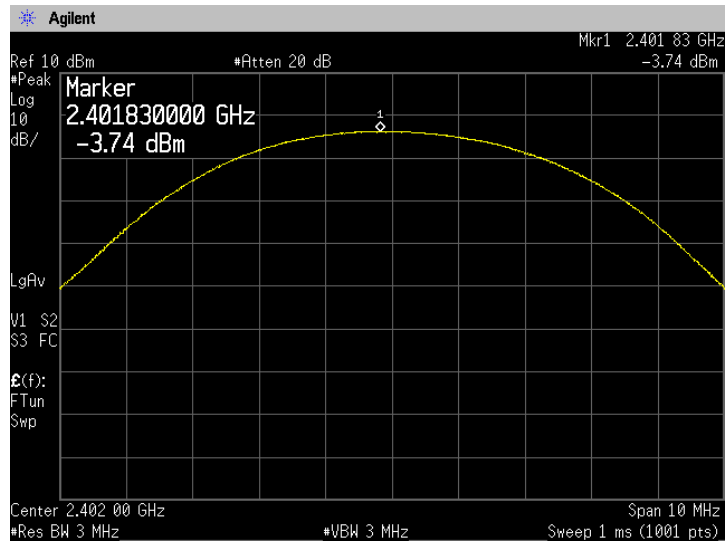

Channel Middle

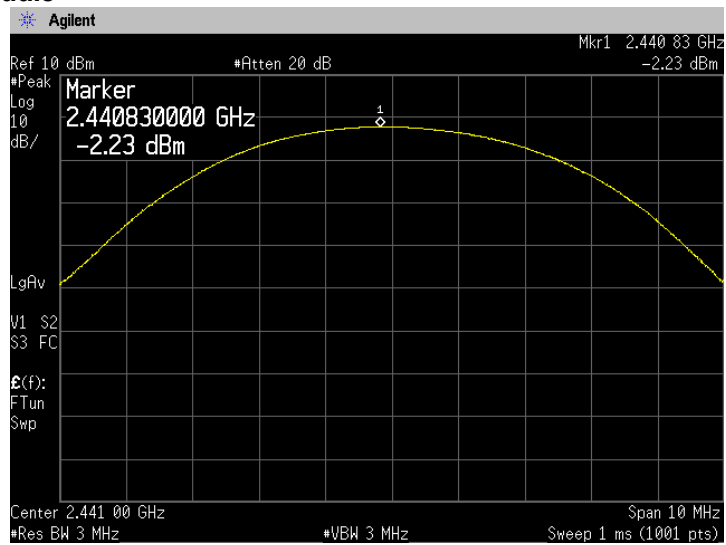

Channel High

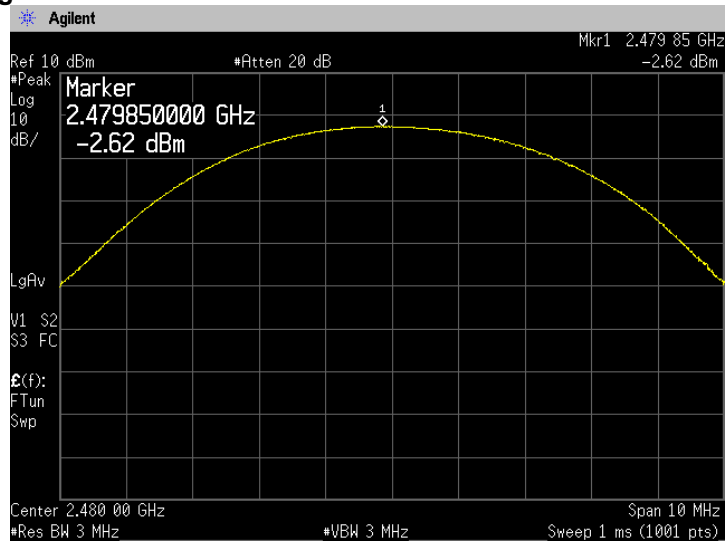

9. Band Edge Compliance of RF Conducted Emissions

9.1 Measurement procedure [FCC 15.247(d)]

The Band Edge is measured with a spectrum analyzer connected to the antenna terminal, while EUT is operating in transmission mode at the appropriate center frequency.

The spectrum analyzer is set to;

- RBW=100kHz, VBW=100kHz, Span=Arbitrary setting, Sweep=auto, Detector=Peak, Trace mode=Max hold

The EUT was set to operate with following conditions.

- No hopping [Channel Low: 2402MHz, Channel High: 2480MHz]
- Hopping

The test mode of EUT is as follows.

- Tx mode

- Test configuration

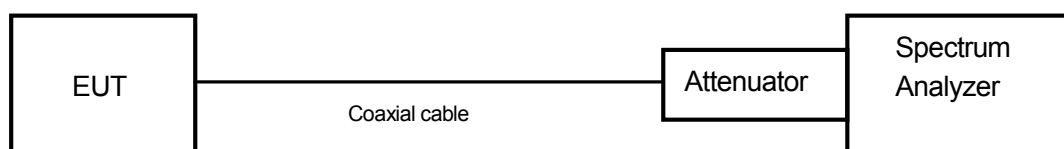

9.2 Limit

In any 100kHz bandwidth outside the frequency band the radio frequency power that is produced by the intentional radiator shall be at least 20dB below that in the 100kHz bandwidth within the band that contains the highest level of the desired power.

9.3 Measurement result

Date : Oct. 7, 2013
 Temperature : 26.0 [°C]
 Humidity : 58.0 [%]
 Test place : Shielded room

Test personnel :

Tested by :

Chiaki Kanno

[Hopping]

Channel	Frequency (MHz)	Packet type	RF Power Level (dBm)	Band-edge Frequency (MHz)	Band-edge Level (dBm)	Difference Level (dBm)	Limit (dBm)	Result
Low	2402	DH5	-3.58	2389.91	-70.99	67.41	At least 20dB below from peak of RF	PASS
		3-DH5	-8.62	2389.91	-71.44	62.82		PASS
High	2480	DH5	-1.94	2483.52	-70.57	68.63	At least 20dB below from peak of RF	PASS
		3-DH5	-6.28	2484.40	-65.46	59.18		PASS



Zacta

[No hopping]

Channel	Frequency (MHz)	Packet type	RF Power Level (dBm)	Band-edge Frequency (MHz)	Band-edge Level (dBm)	Difference Level (dBm)	Limit (dBm)	Result
Low	2402	DH5	-3.12	2389.84	-71.48	68.36	At least 20dB	PASS
		3-DH5	-6.14	2389.81	-71.10	64.96		PASS
High	2480	DH5	-2.10	2483.77	-68.61	66.51	below from peak of RF	PASS
		3-DH5	-5.22	2483.52	-62.98	57.76		PASS



Zacta

9.4 Trace data
[Hopping]
Channel Low
DH5

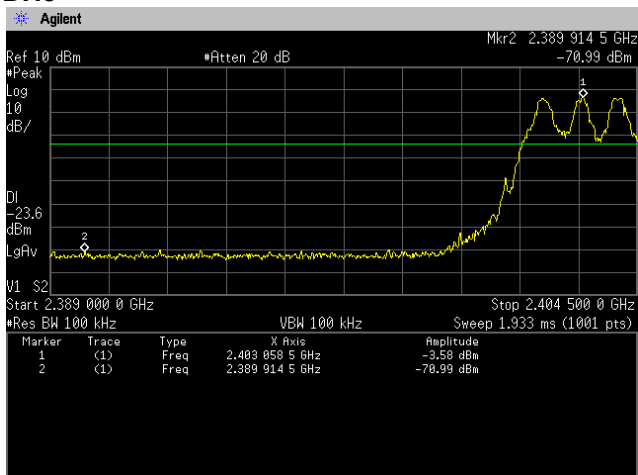

3-DH5

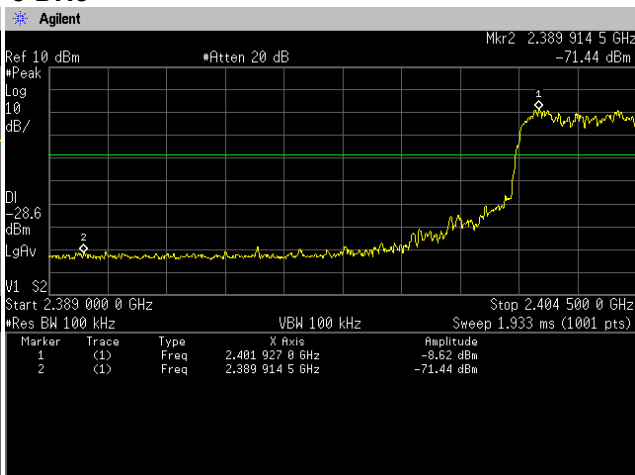

Channel High
DH5

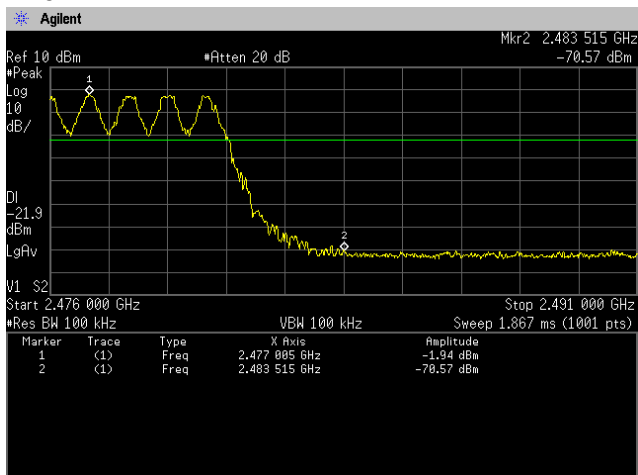

3-DH5

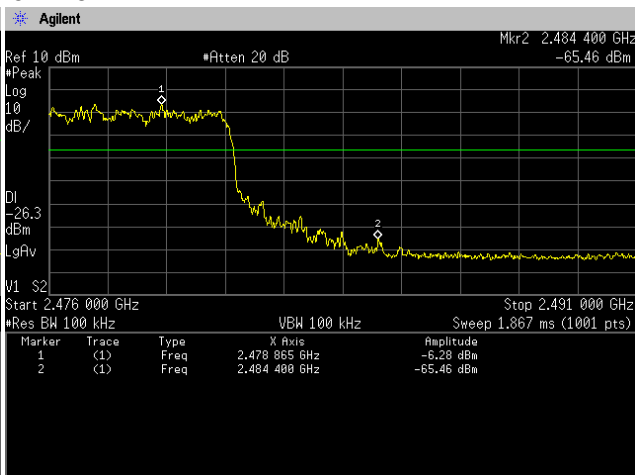



Zacta

**[No hopping]
Channel Low
DH5**

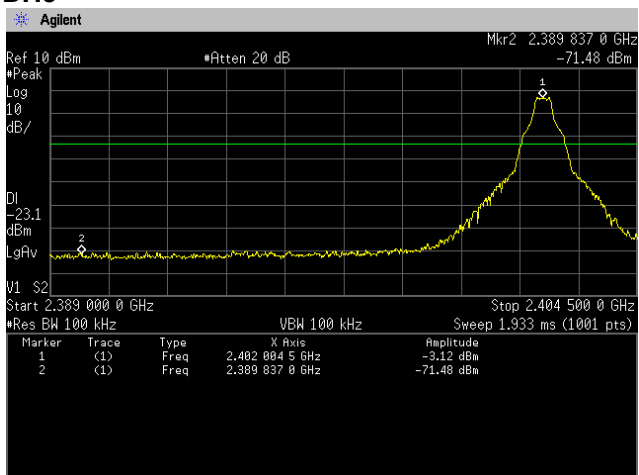

3-DH5

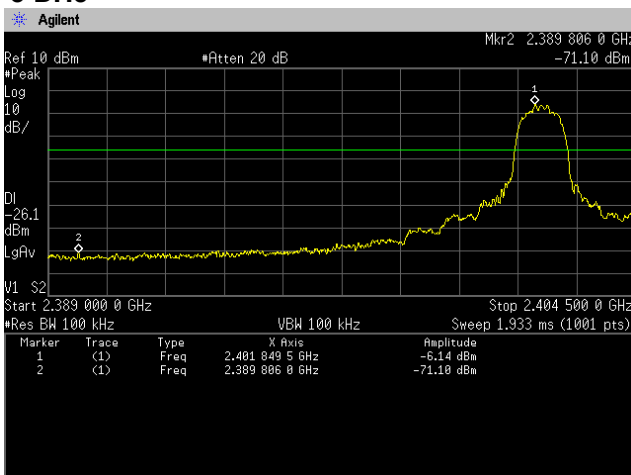

**Channel High
DH5**

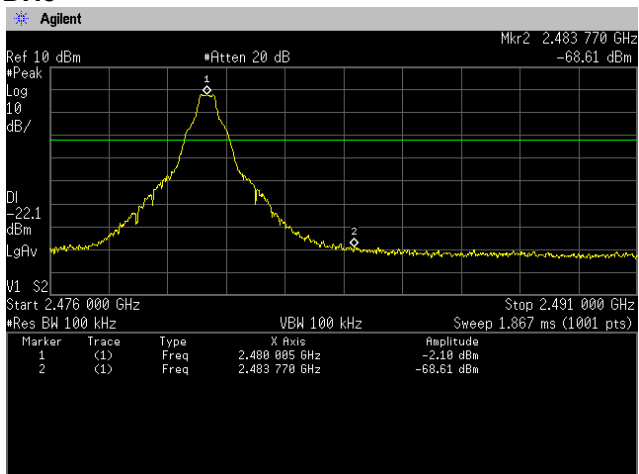

3-DH5

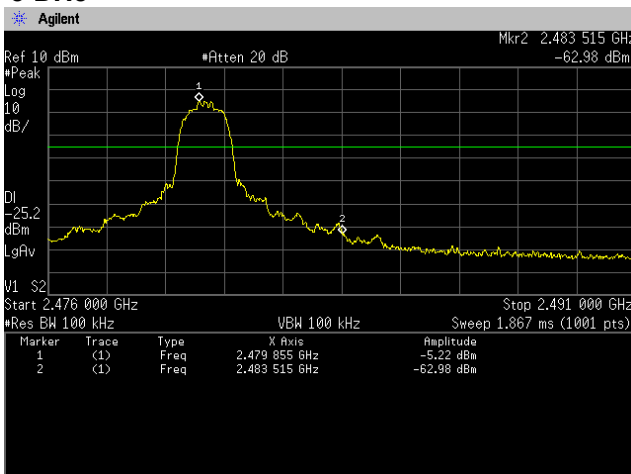

10. Spurious emissions - Conducted -

10.1 Measurement procedure [FCC 15.247(d)]

The spurious emissions (Conducted) are measured with a spectrum analyzer connected to the antenna terminal, while EUT is operating in transmission mode at the appropriate center frequency.

The spectrum analyzer is set to;

- RBW=100kHz, VBW=300kHz, Span=Arbitrary setting, Sweep=auto, Detector=Peak, Trace mode=Max hold

The EUT was set to operate with following conditions.

- No hopping [Channel Low: 2402MHz, Channel Middle: 2441MHz, Channel High: 2480MHz]

The test mode of EUT is as follows.

- Tx mode

- Test configuration

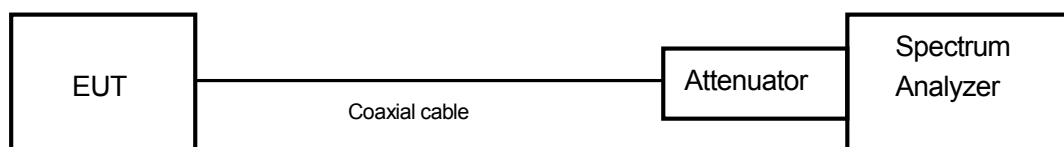

10.2 Limit

In any 100kHz bandwidth outside the frequency band the radio frequency power that is produced by the intentional radiator shall be at least 20dB below that in the 100kHz bandwidth within the band that contains the highest level of the desired power.

10.3 Measurement result

Date : Oct. 7, 2013
 Temperature : 26.0 [°C]
 Humidity : 58.0 [%]
 Test place : Shielded room

Test personnel :

Tested by :

Chiaki Kanno

Channel	Frequency [MHz]	Limit [dB]	Results Chart	Result
Low	2402	At least 20dB below from peak of RF	See the trace Data	PASS
Middle	2441	At least 20dB below from peak of RF	See the trace Data	PASS
High	2480	At least 20dB below from peak of RF	See the trace Data	PASS



Zacta

10.4 Trace data
[DH5]
Channel Low
30MHz-1GHz

1GHz-5GHz

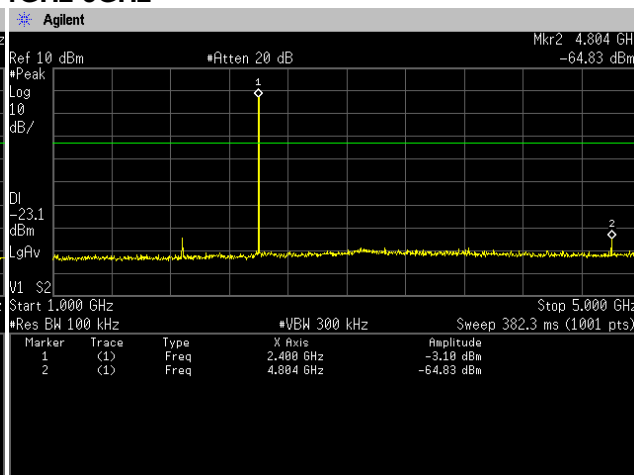
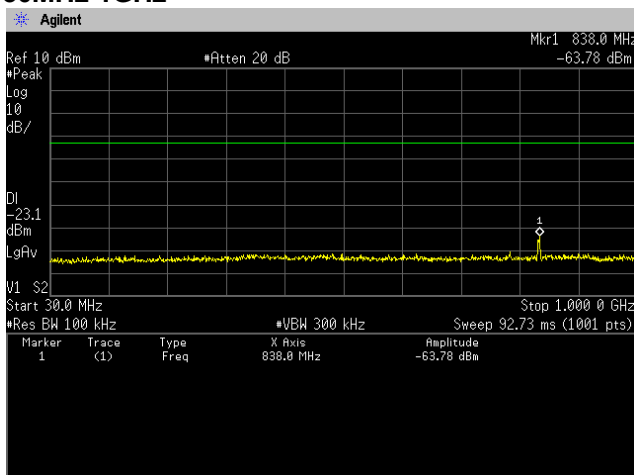

5GHz-10GHz

10GHz-15GHz

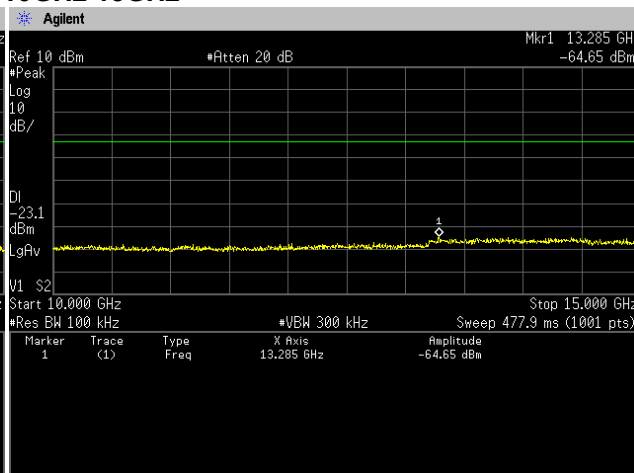
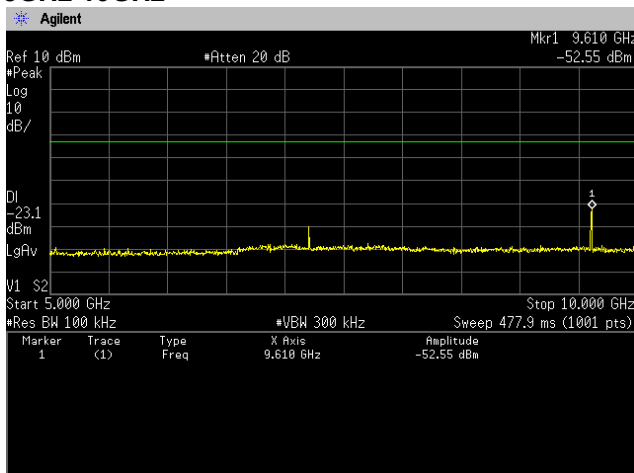

15GHz-20GHz

20GHz-25GHz

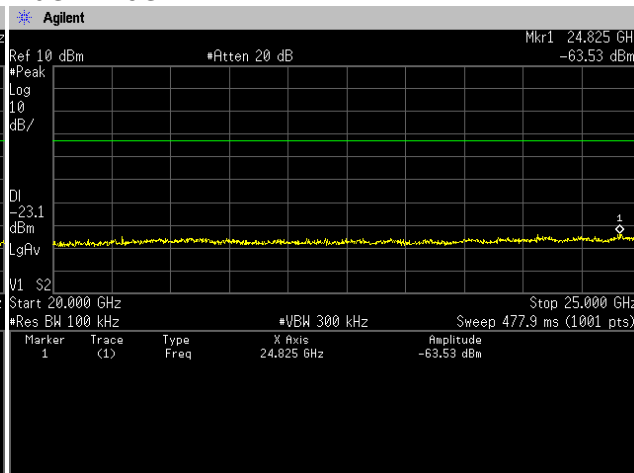
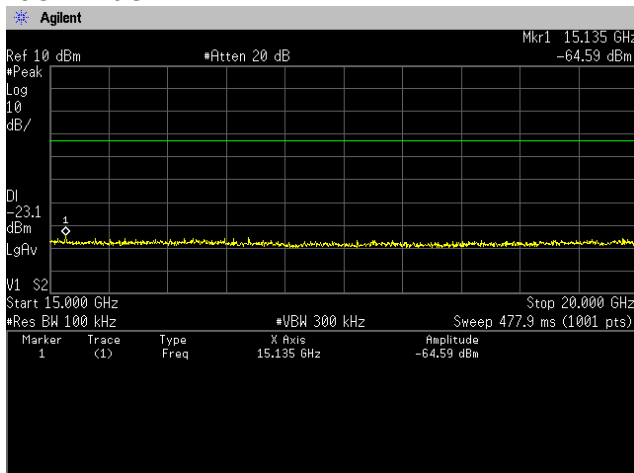



Zacta

Channel Middle 30MHz-1GHz

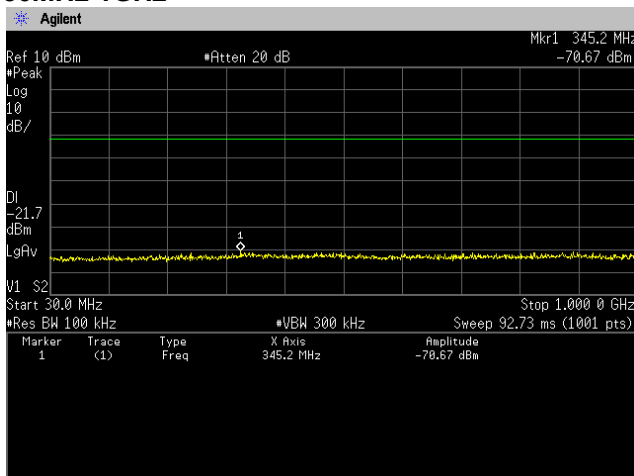

1GHz-5GHz

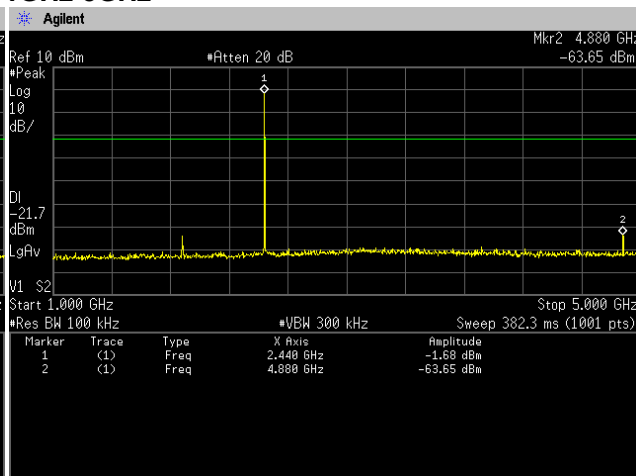

5GHz-10GHz

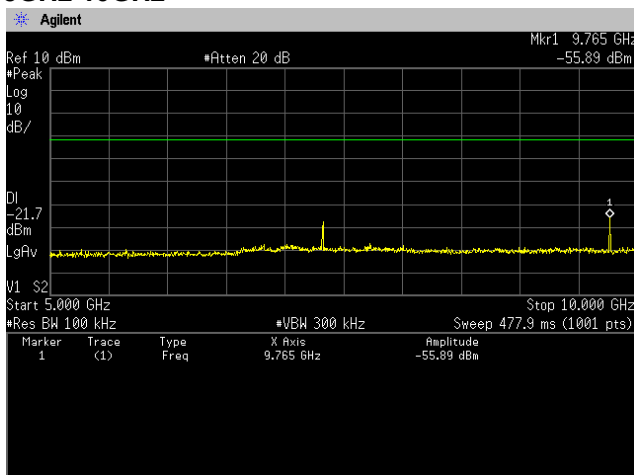

10GHz-15GHz

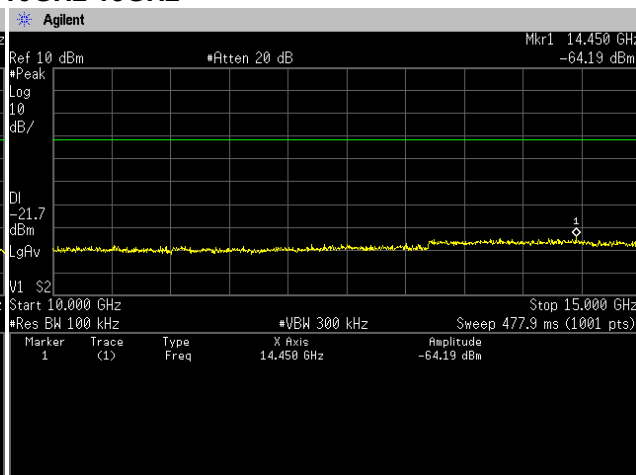

15GHz-20GHz

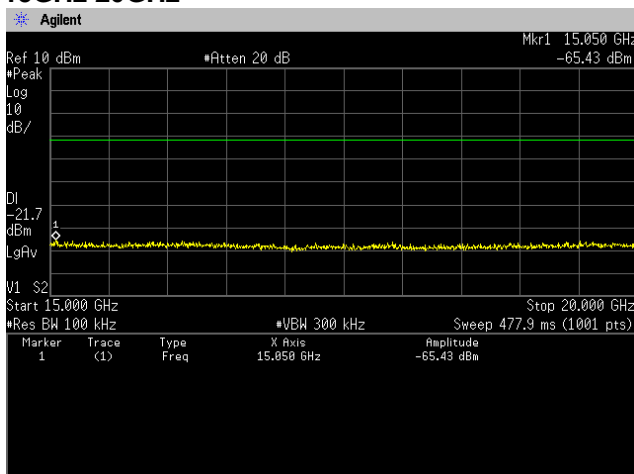

20GHz-25GHz

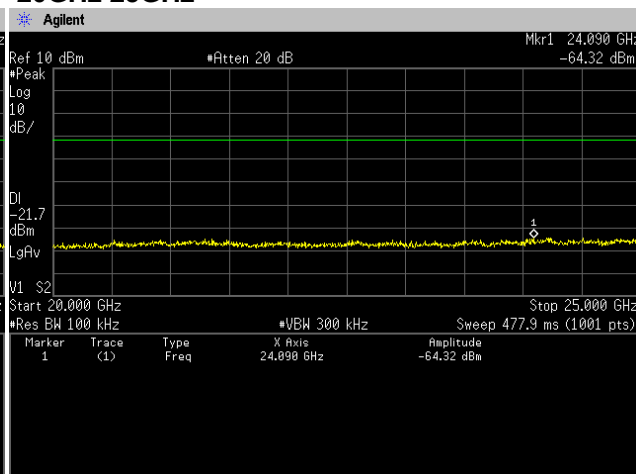



Zacta

Channel High 30MHz-1GHz

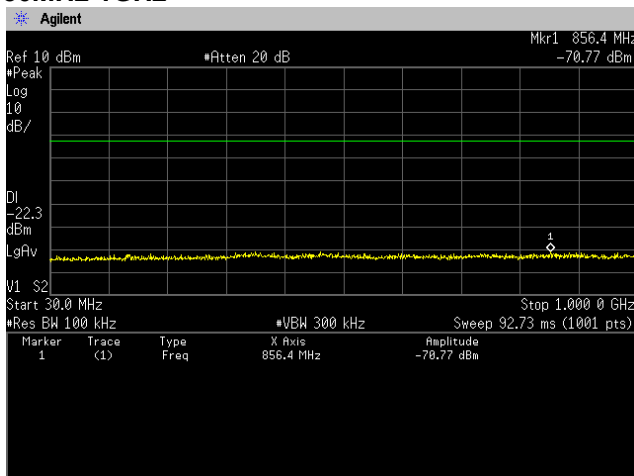

1GHz-5GHz

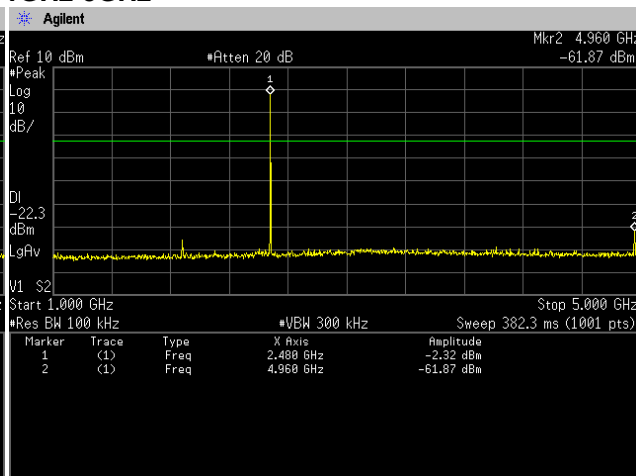

5GHz-10GHz

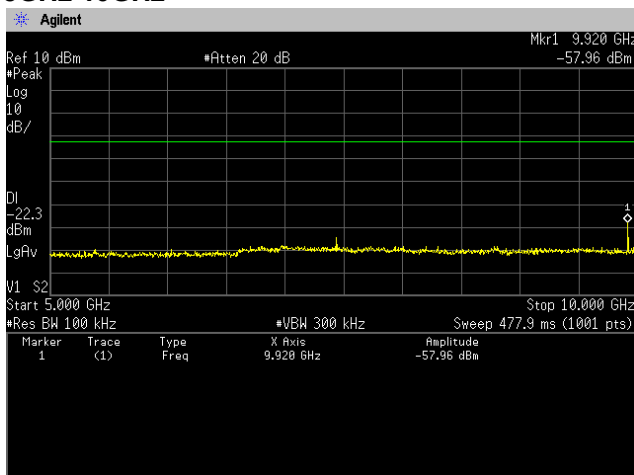

10GHz-15GHz

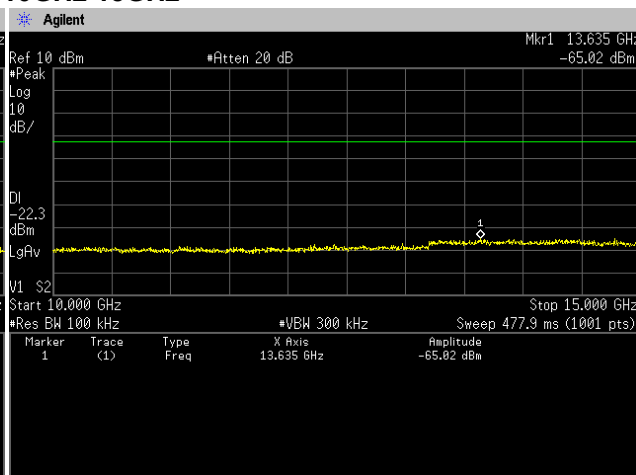

15GHz-20GHz

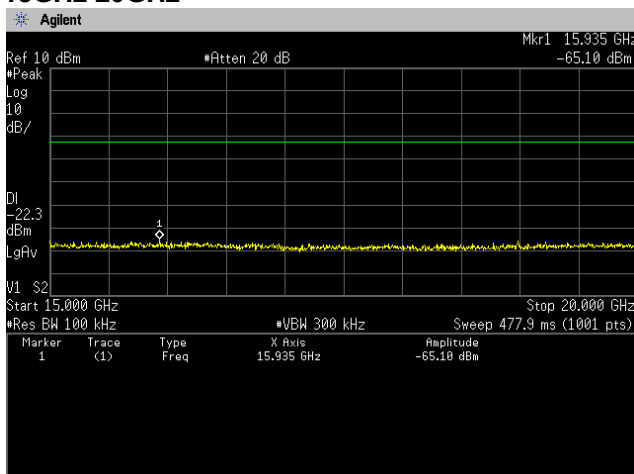

20GHz-25GHz

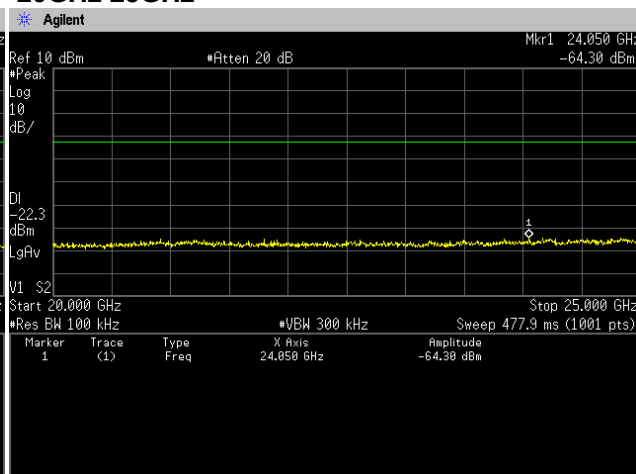



Zacta

**[3-DH5]
Channel Low
30MHz-1GHz**

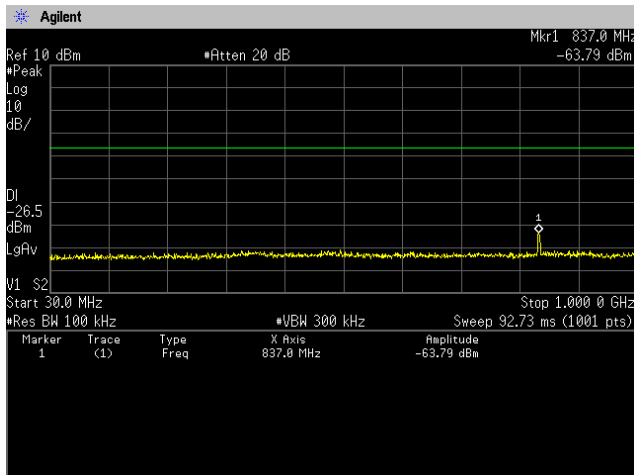

1GHz-5GHz

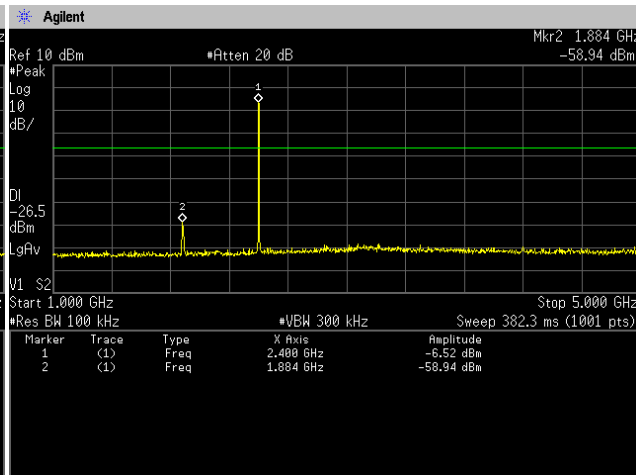

5GHz-10GHz

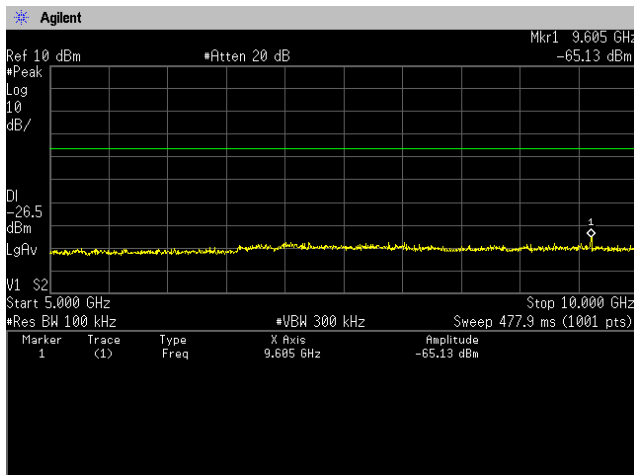

10GHz-15GHz

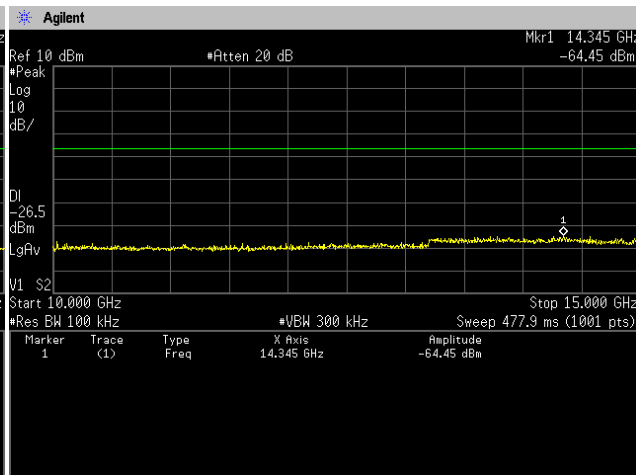

15GHz-20GHz

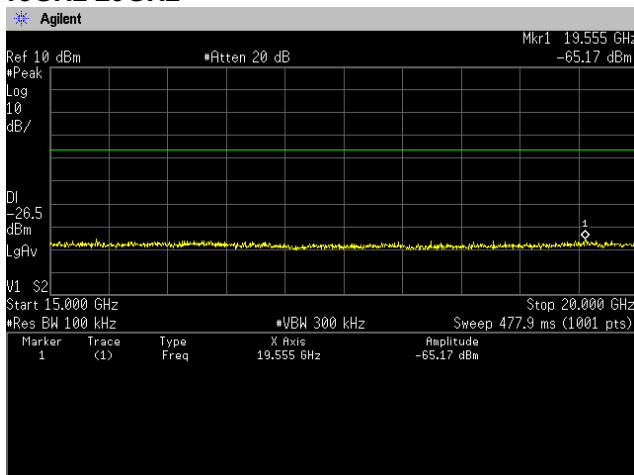

20GHz-25GHz

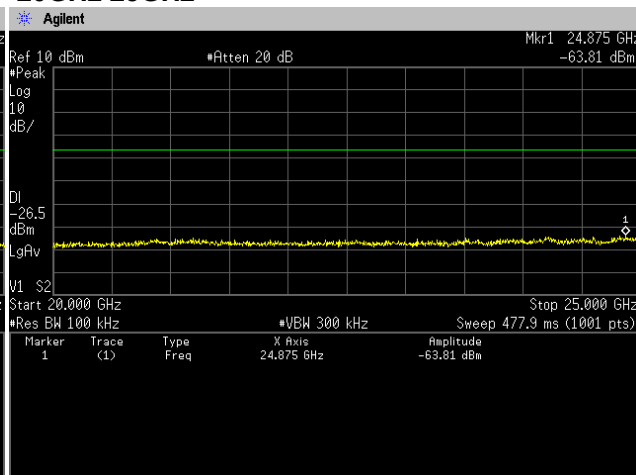



Zacta

Channel Middle 30MHz-1GHz

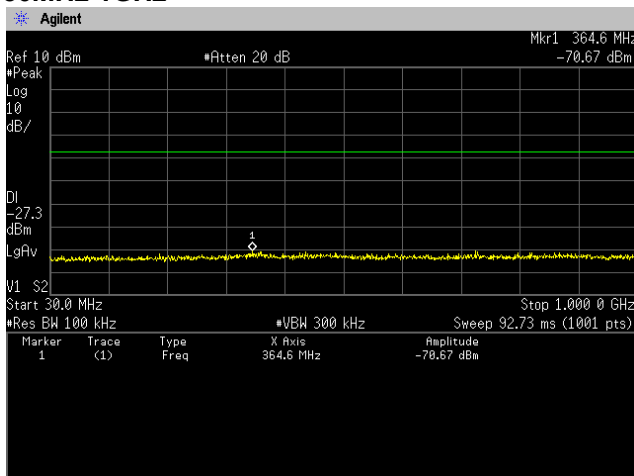

1GHz-5GHz

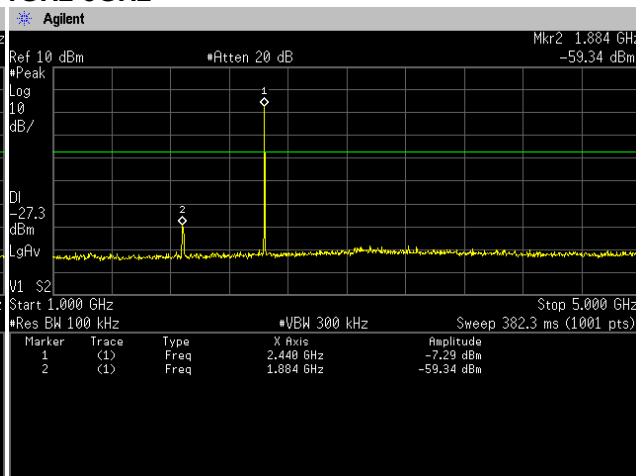

5GHz-10GHz

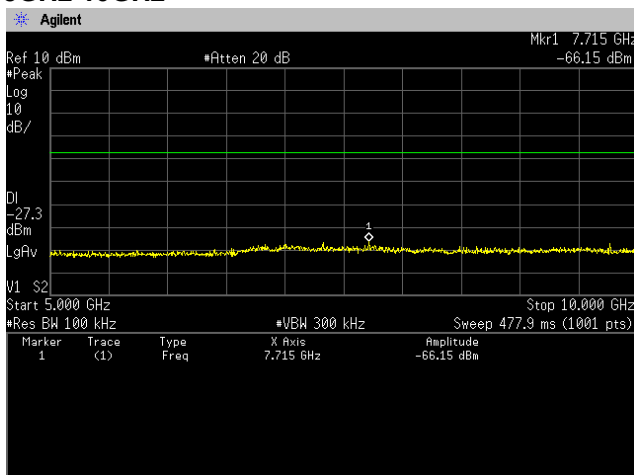

10GHz-15GHz

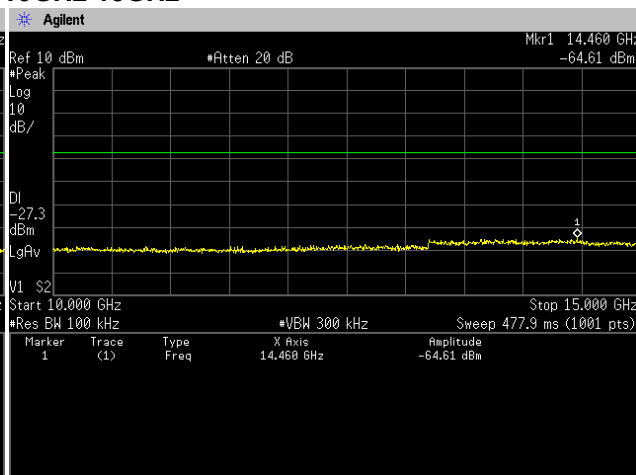

15GHz-20GHz

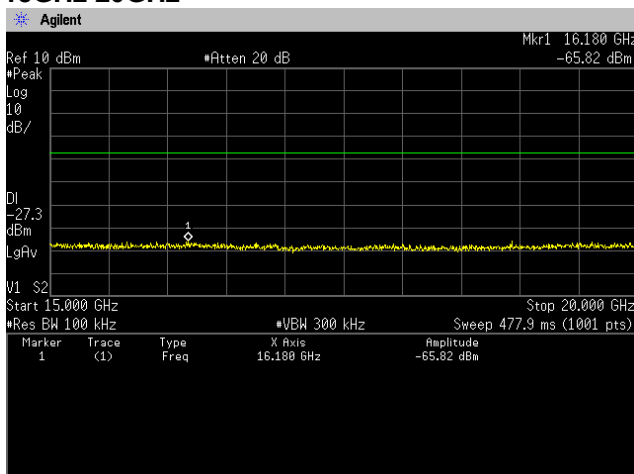

20GHz-25GHz

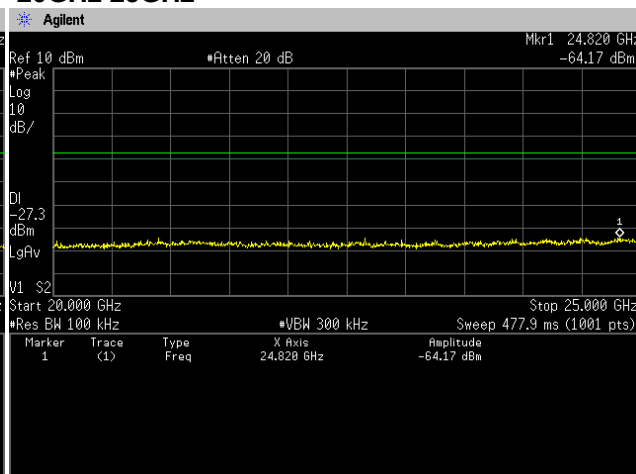



Zacta

Channel High 30MHz-1GHz

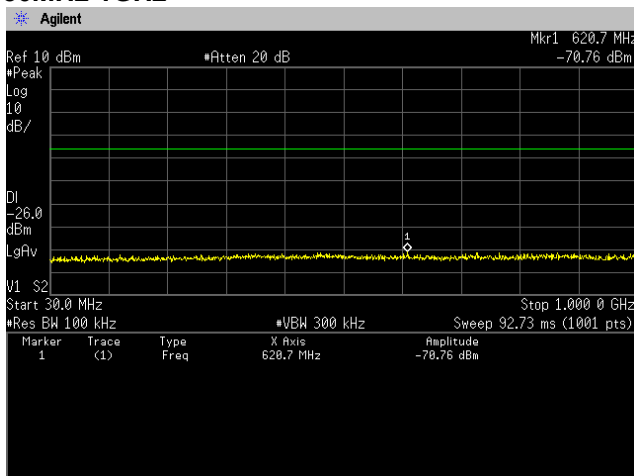

1GHz-5GHz

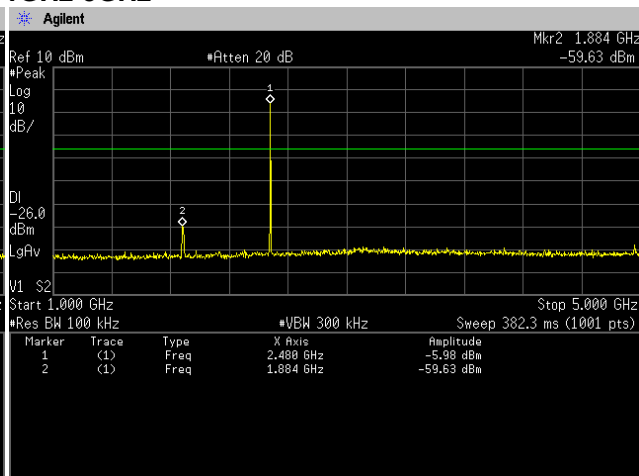

5GHz-10GHz

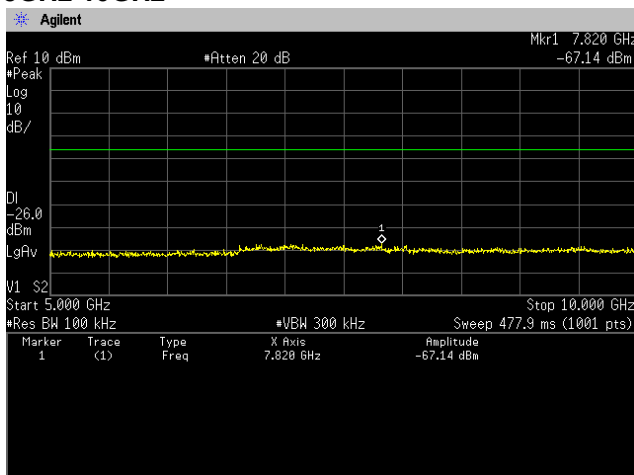

10GHz-15GHz

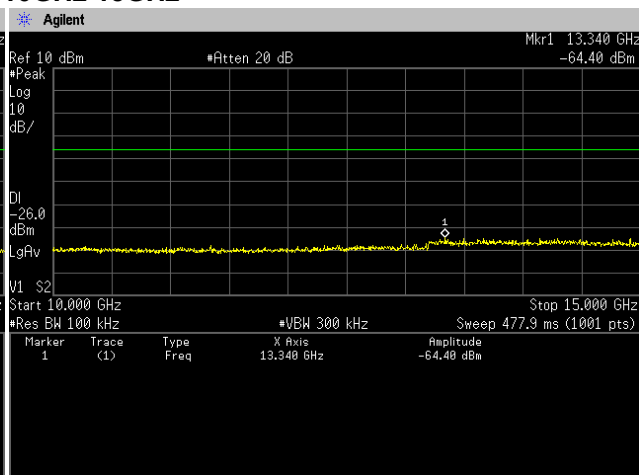

15GHz-20GHz

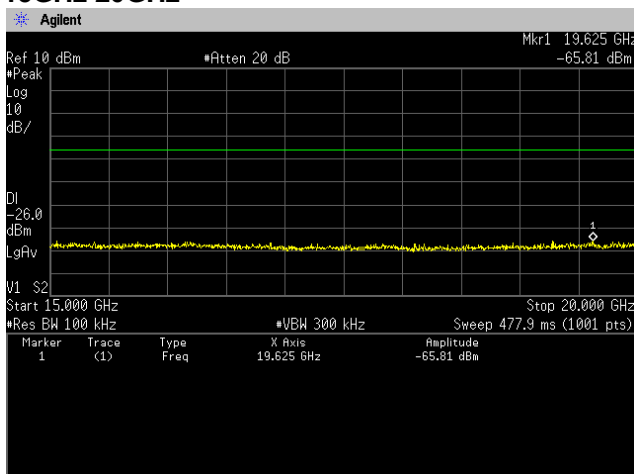

20GHz-25GHz

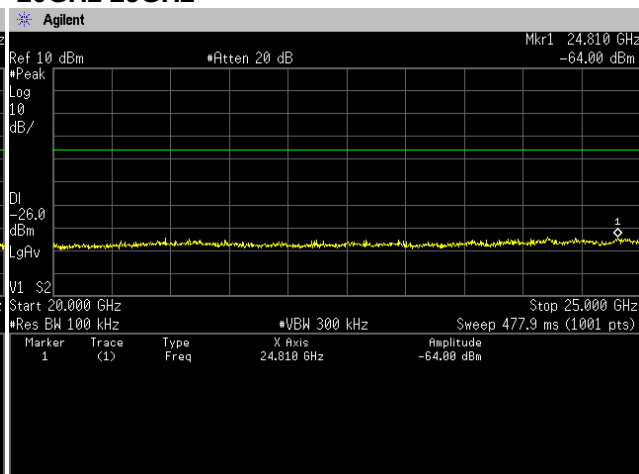

11. Spurious Emissions - Radiated -

11.1 Measurement procedure

[FCC 247(d), 15,205, 15.209]

Test was applied by following conditions.

Test method	:	ANSI C63.4
Frequency range	:	9kHz to 25GHz
Test place	:	3m Semi-anechoic chamber
EUT was placed on	:	FRP table / (W)2.0m × (D)1.0m × (H)0.8m
Antenna distance	:	3m
Test receiver setting	:	Below 1GHz
- Detector	:	Average (9kHz-90kHz, 110kHz-490kHz), Quasi-peak
- Bandwidth	:	200Hz, 120kHz
Spectrum analyzer setting	:	Above 1GHz
- Peak	:	RBW=1MHz, VBW=1MHz, Span=0Hz, Sweep=auto
- Average	:	RBW=1MHz, VBW=10Hz, Span=0Hz, Sweep=auto
	:	Display mode=Linear

Radiated emission measurements are performed at 3m distance with the broadband antenna (Loop antenna, Biconical antenna, Log periodic antenna and Double ridged guide antenna). The antenna is positioned both the horizontal and vertical planes of polarization and height is varied 1m to 4m and stopped at height producing the maximum emission. As for the Loop antenna, it is positioned with its plane vertical, and the center of the Loop antenna is 1m above the ground plane.

The EUT is Placed on a turntable, which is 0.8m above ground plane. The turntable shall be rotated for 360 degrees to determine the position of maximum emission level. The test results represent the worst case emission for each emission with manipulating the EUT, support equipment, interconnecting cables and varying the mode of operation. Sufficient time for the EUT, support equipment, and test equipment are allowed in order for them to warm up to their normal operating condition.

The EUT was set to operate with following conditions.

- No hopping [Channel Low: 2402MHz, Channel Middle: 2441MHz, Channel High: 2480MHz]

The test mode of EUT is as follows.

- Tx mode, Rx mode

- Test configuration

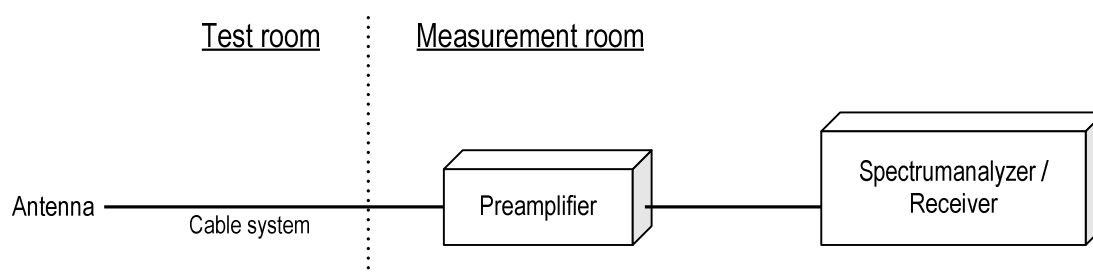

11.2 Calculation method

[9kHz to 150kHz]

Emission level = Reading + (Ant. factor + Cable system loss)

Margin = Limit – Emission level

[150kHz to 25GHz]

Emission level = Reading + (Ant. factor + Cable system loss – Amp. Gain)

Margin = Limit – Emission level

11.3 Limit

Frequency [MHz]	Field strength		Distance [m]
	[uV/m]	[dBuV/m]	
0.009-0.490	2400 / F [kHz]	20logE [uV/m]	300
0.490-1.705	24000 / F [kHz]	20logE [uV/m]	30
1.705-30	30	29.5	30
30-88	100	40.0	3
88-216	150	43.5	3
216-960	200	46.0	3
Above 960	300	54.0	3

Note:

1. The lower limit shall apply at the transition frequencies.
2. Emission level [dBuV/m] = 20log Emission [uV/m]
3. As shown in 15.35(b), for frequencies above 1000MHz, the field strength limits are based on average detector, however, the peak field strength of any emission shall not exceed the maximum permitted average limits, specified above by more than 20dB under any condition modulation.



Zacta

11.4 Test data

Date : Oct. 15, 2013 Test personnel :
 Temperature : 23.0 [°C]
 Humidity : 50.0 [%] Tested by :
 Test place : 3m Semi-anechoic chamber Chiaki kanno

Date : Oct. 16, 2013 Test personnel :
 Temperature : 25.0 [°C]
 Humidity : 47.0 [%] Tested by :
 Test place : 3m Semi-anechoic chamber Chiaki kanno

<Tx mode>

[DH5]

Channel Low

No.	Frequency [MHz]	(P)	Reading PK [dB(μV)]	Reading AV [dB(μV)]	c. f [dB(1/m)]	Result PK [dB(μV/m)]	Result AV [dB(μV/m)]	Limit PK [dB(μV/m)]	Limit AV [dB(μV/m)]	Margin PK [dB]	Margin AV [dB]	Height [cm]	Angle [°]
1	4804.007	H	45.0	34.7	8.6	53.6	43.3	74.0	54.0	20.4	10.7	200.0	164.0
2	4804.024	V	47.1	36.7	8.6	55.7	45.3	74.0	54.0	18.3	8.7	300.0	99.0

Channel Middle

No.	Frequency [MHz]	(P)	Reading PK [dB(μV)]	Reading AV [dB(μV)]	c. f [dB(1/m)]	Result PK [dB(μV/m)]	Result AV [dB(μV/m)]	Limit PK [dB(μV/m)]	Limit AV [dB(μV/m)]	Margin PK [dB]	Margin AV [dB]	Height [cm]	Angle [°]
1	4882.009	H	48.3	40.6	9.0	57.3	49.6	74.0	54.0	16.7	4.4	300.0	288.0
2	4882.014	V	50.5	43.9	9.0	59.5	52.9	74.0	54.0	14.5	1.1	200.0	320.0

Channel High

No.	Frequency [MHz]	(P)	Reading PK [dB(μV)]	Reading AV [dB(μV)]	c. f [dB(1/m)]	Result PK [dB(μV/m)]	Result AV [dB(μV/m)]	Limit PK [dB(μV/m)]	Limit AV [dB(μV/m)]	Margin PK [dB]	Margin AV [dB]	Height [cm]	Angle [°]
1	4960.016	H	46.6	37.0	9.3	55.9	46.3	74.0	54.0	18.1	7.7	117.0	141.0
2	4960.019	V	48.4	39.9	9.3	57.7	49.2	74.0	54.0	16.3	4.8	100.0	14.0
3	9919.405	H	45.6	33.2	17.5	63.1	50.7	74.0	54.0	10.9	3.3	129.0	18.0

Note:

1. Emission Level (Margin) = Limit - [Reading + Factor (Antenna + Cable – Amp)]
2. No emission were detected in frequency range 9kHz to 1000MHz at the 3 meters distance.



Zacta

[3-DH5]**Channel Low**

No.	Frequency [MHz]	(P)	Reading PK [dB(μV)]	Reading AV [dB(μV)]	c. f [dB(1/m)]	Result PK [dB(μV/m)]	Result AV [dB(μV/m)]	Limit PK [dB(μV/m)]	Limit AV [dB(μV/m)]	Margin PK [dB]	Margin AV [dB]	Height [cm]	Angle [°]
1	4804.000	H	44.8	32.0	8.6	53.4	40.6	74.0	54.0	20.6	13.4	100.0	43.0
2	4804.017	V	44.2	32.2	8.6	52.8	40.8	74.0	54.0	21.2	13.2	100.0	257.0

Channel Middle

No.	Frequency [MHz]	(P)	Reading PK [dB(μV)]	Reading AV [dB(μV)]	c. f [dB(1/m)]	Result PK [dB(μV/m)]	Result AV [dB(μV/m)]	Limit PK [dB(μV/m)]	Limit AV [dB(μV/m)]	Margin PK [dB]	Margin AV [dB]	Height [cm]	Angle [°]
1	4882.007	H	45.8	33.8	9.0	54.8	42.8	74.0	54.0	19.2	11.2	100.0	89.0
2	4882.000	V	45.9	34.1	9.0	54.9	43.1	74.0	54.0	19.1	10.9	100.0	0.0

Channel High

No.	Frequency [MHz]	(P)	Reading PK [dB(μV)]	Reading AV [dB(μV)]	c. f [dB(1/m)]	Result PK [dB(μV/m)]	Result AV [dB(μV/m)]	Limit PK [dB(μV/m)]	Limit AV [dB(μV/m)]	Margin PK [dB]	Margin AV [dB]	Height [cm]	Angle [°]
1	4960.011	H	44.8	32.1	9.3	54.1	41.4	74.0	54.0	19.9	12.6	100.0	340.0
2	4960.037	V	45.0	33.1	9.3	54.3	42.4	74.0	54.0	19.7	11.6	100.0	19.0

Note:

1. Emission Level (Margin) = Limit - [Reading + Factor (Antenna + Cable – Amp)]
2. No emission were detected in frequency range 9kHz to 1000MHz at the 3 meters distance.

<Rx mode>

Note: No emissions were observed during Radiated testing.

12. Restricted Band of Operation

12.1 Measurement procedure [FCC 247(d), 15.205, 15.209]

Test was applied by following conditions.

Test method : ANSI C63.4
 Test place : 3m Semi-anechoic chamber
 EUT was placed on : FRP table / (W)2.0m × (D)1.0m × (H)0.8m
 Antenna distance : 3m

Spectrum analyzer setting
 - Peak : RBW=1MHz, VBW=1MHz, Span=Arbitrary setting, Sweep=auto
 - Average : RBW=1MHz, VBW=10Hz, Span=Arbitrary setting, Sweep=auto
 Display mode=Linear

Radiated emission measurements are performed at 3m distance with the broadband antenna (Double ridged guide antenna). The antenna is positioned both the horizontal and vertical planes of polarization and height is varied 1m to 4m and stopped at height producing the maximum emission.

The EUT is Placed on a turntable, which is 0.8m above ground plane. The turntable shall be rotated for 360 degrees to determine the position of maximum emission level. The test results represent the worst case emission for each emission with manipulating the EUT, support equipment, interconnecting cables and varying the mode of operation. Sufficient time for the EUT, support equipment, and test equipment are allowed in order for them to warm up to their normal operating condition.

The EUT was set to operate with following conditions.

- No hopping [Channel Low: 2402MHz, Channel High: 2480MHz]

The test mode of EUT is as follows.

- Tx mode

- Test configuration

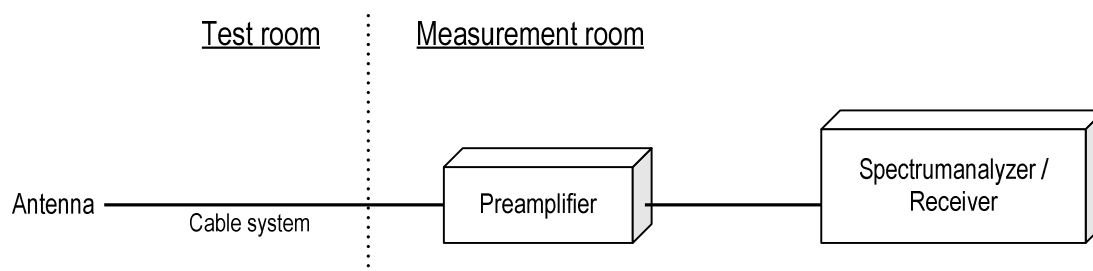

12.2 Limit

Emission at the boundary of the restricted band provided by 15.205 shall be lower than 15.209 limit.

12.3 Measurement Result

Channel	Frequency [MHz]	Results Chart	Result
Low	2402	See the Trace Data	Pass
High	2480	See the Trace Data	Pass



Zacta

12.4 Test data

Date : Oct. 16, 2013
 Temperature : 25.0 [°C]
 Humidity : 47.0 [%]
 Test place : 3m Semi-anechoic chamber

Test personnel :
 Tested by : Chiaki Kanno

[DH5] Channel Low Horizontal Peak

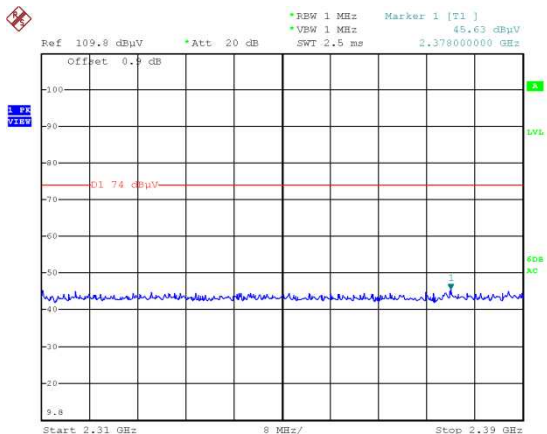

Date: 16.OCT.2013 18:18:15

Average

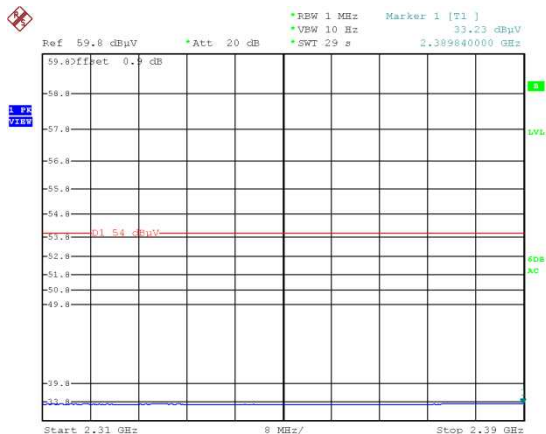

Date: 16.OCT.2013 18:19:33

Vertical Peak

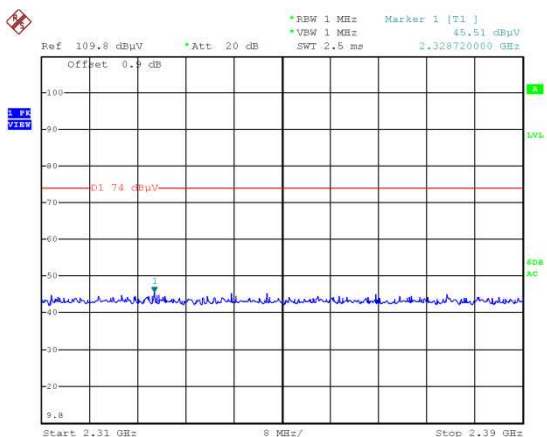

Date: 16.OCT.2013 18:22:58

Average

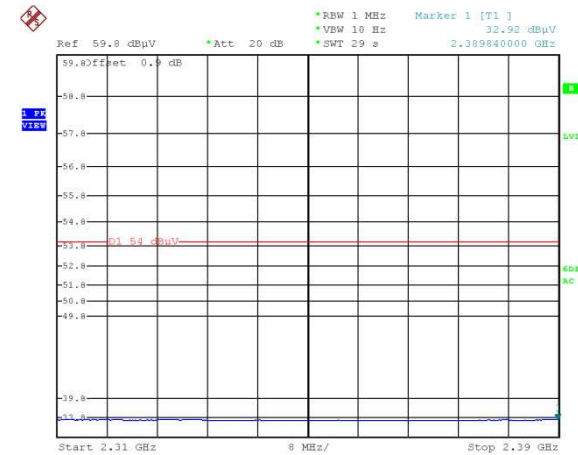

Date: 16.OCT.2013 18:24:13



Zacta

Channel High Horizontal Peak

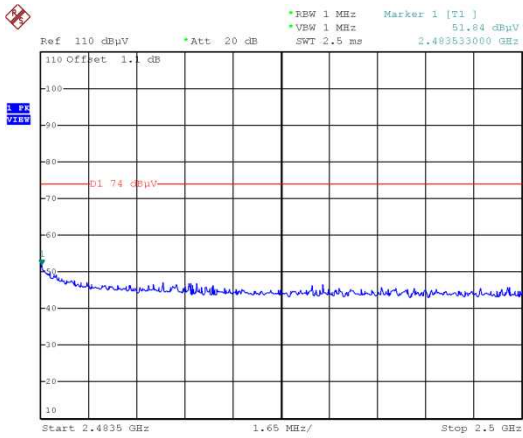

Date: 16.OCT.2013 17:18:13

Average

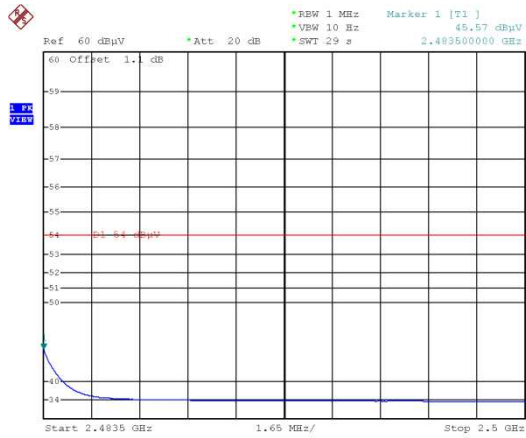

Date: 16.OCT.2013 17:19:31

Vertical Peak

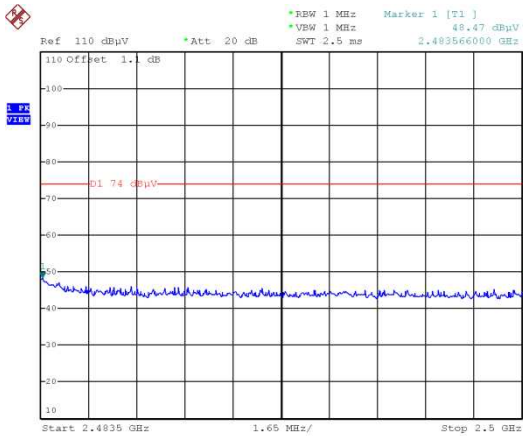

Date: 16.OCT.2013 16:36:26

Average

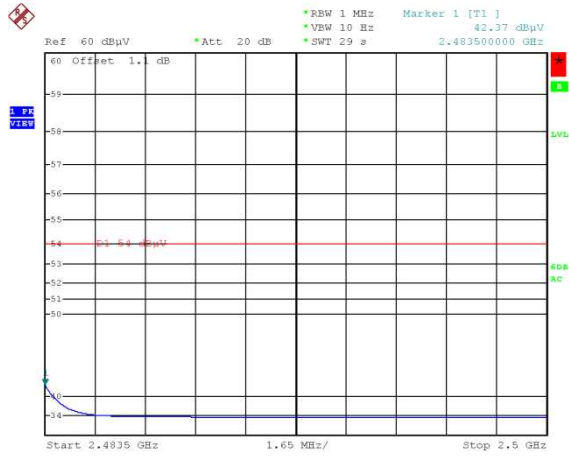

Date: 16.OCT.2013 16:36:59



Zacta

[3-DH5] Channel Low Horizontal Peak

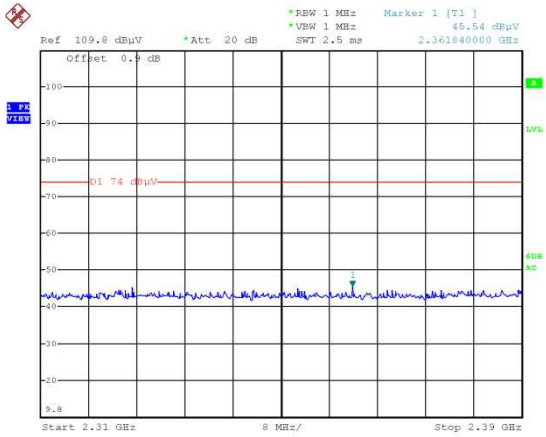

Date: 16.OCT.2013 18:29:36

Average

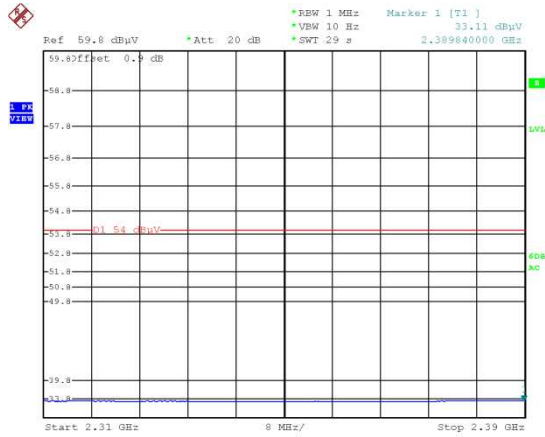

Date: 16.OCT.2013 18:31:02

Vertical Peak

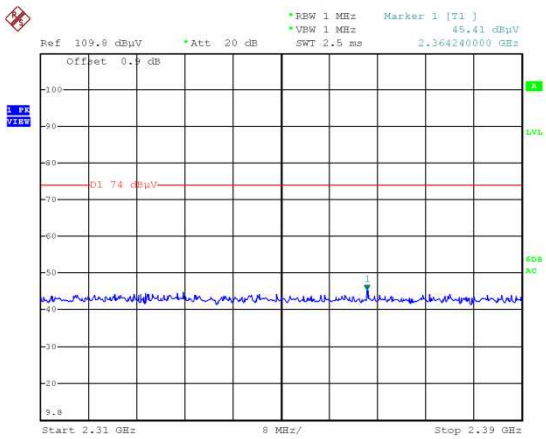

Date: 16.OCT.2013 18:42:58

Average

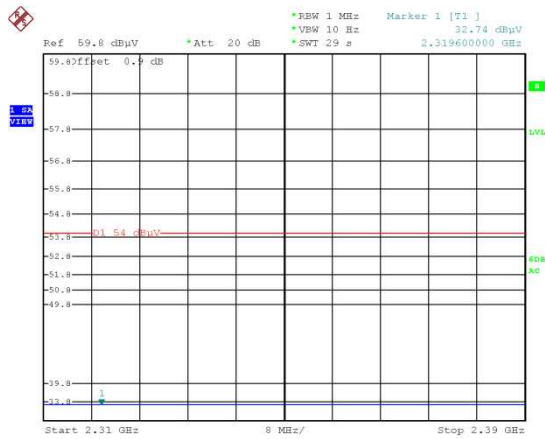

Date: 16.OCT.2013 18:43:58



Zacta

Channel High Horizontal Peak

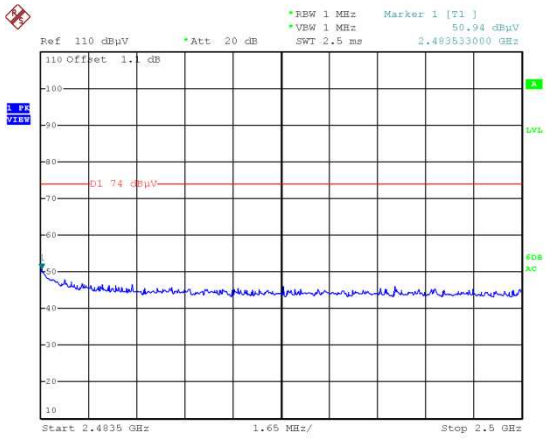

Date: 16.OCT.2013 17:39:34

Average

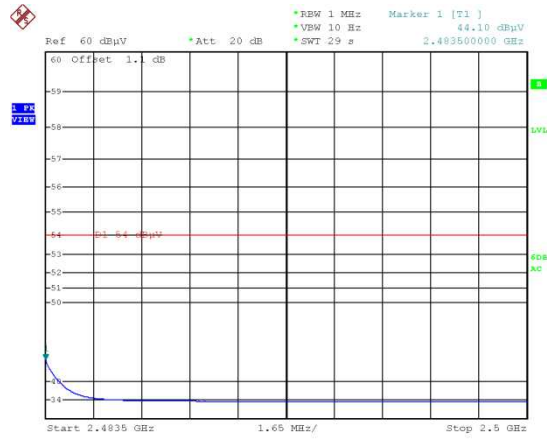

Date: 16.OCT.2013 17:40:42

Vertical Peak

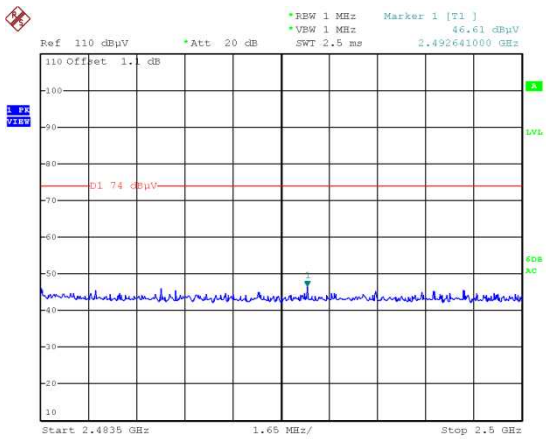

Date: 16.OCT.2013 17:43:46

Average

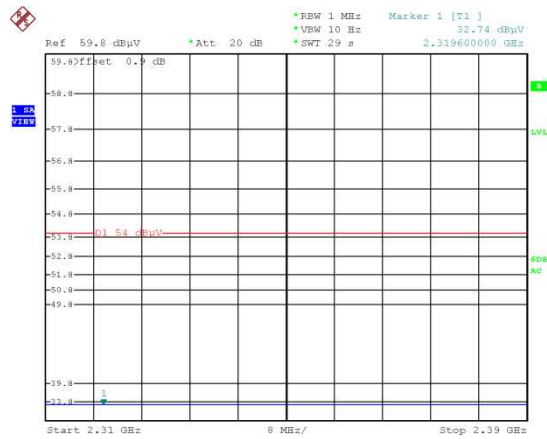

Date: 16.OCT.2013 18:43:58

13. AC Power Line Conducted Emissions

13.1 Measurement procedure [FCC 15.207]

Test was applied by following conditions.

Test method	: ANSI C63.4
Frequency range	: 0.15MHz to 30MHz
Test place	: 3m Semi-anechoic chamber
EUT was placed on	: FRP table / (W)2.0m × (D)1.0m × (H)0.8m
Vertical Metal Reference Plane	: (W)2.0m × (H)2.0m 0.4m away from EUT
Test receiver setting	
- Detector	: Quasi-peak, Average
- Bandwidth	: 9kHz

EUT and peripherals are connected to 50Ω/50μH Line Impedance Stabilization Network (LISN) which are connected to reference ground plane, and are placed 80cm away from EUT. Excess of AC power cable is bundled in center.

LISN for peripheral is terminated in 50Ω.

EUT operating mode is selected to emit the maximum noise. Overall frequency range is investigated with spectrum analyzer using peak detector. Maximum emission configuration is determined by manipulating the EUT, peripherals, interconnecting cables. Then, emission measurements are performed with test receiver in above setting to each current-carrying conductor of the mains port. Sufficient time for EUT, peripherals and test equipment is provided in order for them to warm up to their normal operating condition. If the average limit is met when using a quasi-peak detector receiver, the EUT shall be deemed to meet both limits.

- Test configuration

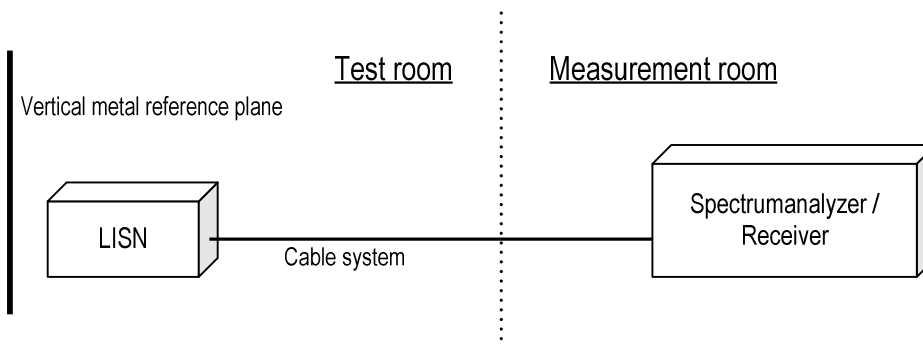

13.2 Calculation method

Emission level = Reading + (LISN. factor + Cable system loss)

Margin = Limit – Emission level

13.3 Limit

Frequency [MHz]	Limit	
	QP [dBuV]	AV [dBuV]
0.15-0.5	66-56*	56-46*
0.5-5	56	46
5-30	60	50

*: The limit decreases linearly with the logarithm of the frequency in the range 0.15MHz to 0.5MHz.



Zacta

13.4 Test data

***** CONDUCTED EMISSION at MAINS PORT *****
 < 3m Semi-anechoic chamber >

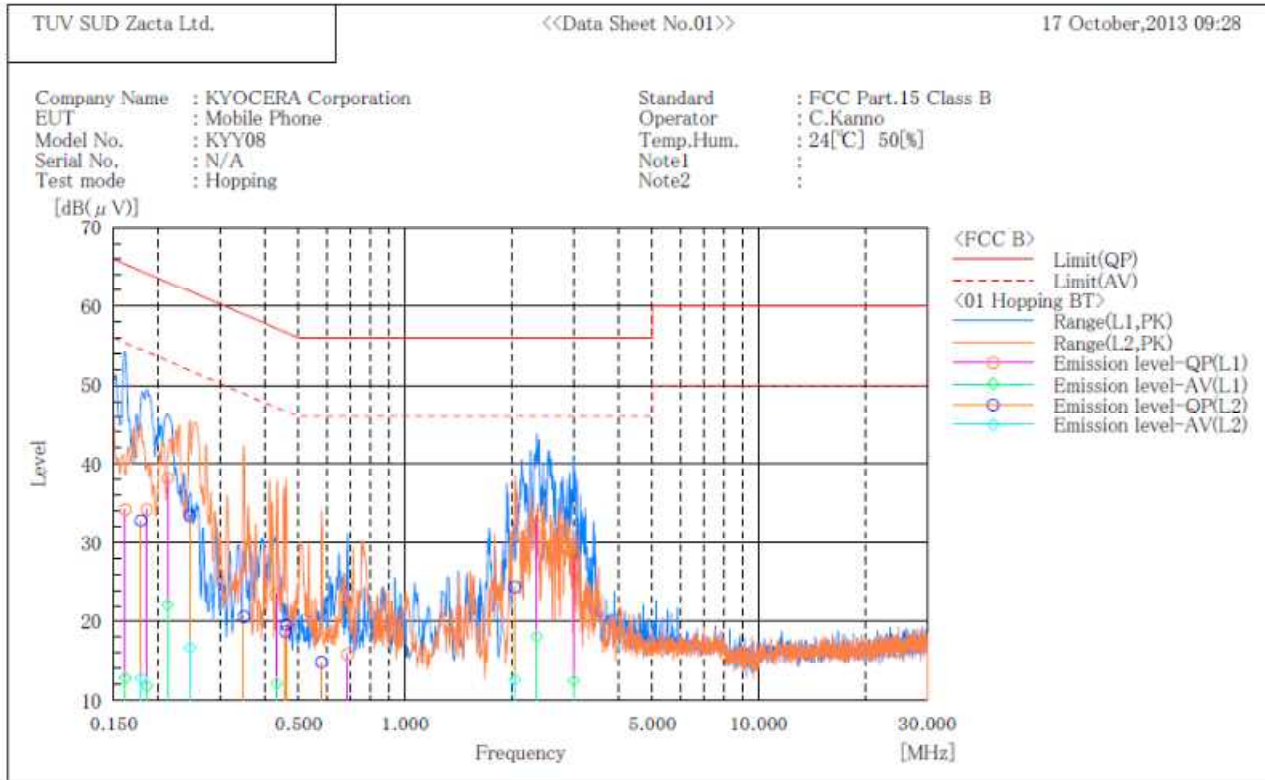

Final Result

--- L1 Phase ---

No.	Frequency [MHz]	Reading QP [dB(μV)]	Reading AV [dB(μV)]	c. f [dB]	Result QP [dB(μV)]	Result AV [dB(μV)]	Limit QP [dB(μV)]	Limit AV [dB(μV)]	Margin QP [dB]	Margin AV [dB]
1	0.16151	23.7	2.3	10.5	34.2	12.8	65.4	55.4	31.2	42.6
2	0.18606	23.8	1.4	10.4	34.2	11.8	64.2	54.2	30.0	42.4
3	0.21292	27.8	11.7	10.4	38.2	22.1	63.1	53.1	24.9	31.0
4	0.4328	13.2	1.8	10.3	23.5	12.1	57.2	47.2	33.7	35.1
5	0.68685	5.5	-2.9	10.3	15.8	7.4	56.0	46.0	40.2	38.6
6	2.35784	23.0	7.7	10.4	33.4	18.1	56.0	46.0	22.6	27.9
7	2.99576	18.0	2.1	10.4	28.4	12.5	56.0	46.0	27.6	33.5

--- L2 Phase ---

No.	Frequency [MHz]	Reading QP [dB(μV)]	Reading AV [dB(μV)]	c. f [dB]	Result QP [dB(μV)]	Result AV [dB(μV)]	Limit QP [dB(μV)]	Limit AV [dB(μV)]	Margin QP [dB]	Margin AV [dB]
1	0.17889	22.4	2.4	10.4	32.8	12.8	64.5	54.5	31.7	41.7
2	0.24625	23.0	6.3	10.4	33.4	16.7	61.9	51.9	28.5	35.2
3	0.34967	10.3	-1.9	10.3	20.6	8.4	59.0	49.0	38.4	40.6
4	0.45887	8.4	-2.0	10.3	18.7	8.3	56.7	46.7	38.0	38.4
5	0.46037	9.3	-2.3	10.3	19.6	8.0	56.7	46.7	37.1	38.7
6	0.5797	4.5	-2.3	10.3	14.8	8.0	56.0	46.0	41.2	38.0
7	2.04102	14.0	2.2	10.4	24.4	12.6	56.0	46.0	31.6	33.4



Zacta

14. Antenna requirement

According to FCC section 15.203, an intentional radiator shall be designed to ensure that no antenna other than that furnished by the responsible party shall be used with the device.

The antenna is a special antenna mounted inside of the EUT. Therefore, the EUT complies with the antenna requirement of FCC section 15.203.

15. Uncertainty of measurement

Expanded uncertainties stated are calculated with a coverage Factor $k=2$.

Please note that these results are not taken into account when determining compliance or non-compliance with test result.

Test item	Measurement uncertainty
Conducted emission at mains port	$\pm 3.0\text{dB}$
Radiated emission (9kHz – 30MHz)	$\pm 4.4\text{dB}$
Radiated emission (30MHz – 1000MHz)	$\pm 4.5\text{dB}$
Radiated emission (1000MHz – 26GHz)	$\pm 3.9\text{dB}$



Zacta

16. Laboratory description

1. Location:

TÜV SÜD Zacta Ltd. Yonezawa Testing Center
 4149-7 Hachimanpara 5-chome Yonezawa-shi Yamagata 992-1128 Japan
 Phone: +81-238-28-2880 Fax: +81-238-28-2888

2. Facility filing information:

1) NVLAP accreditation: NVLAP Lab. code: 200306-0

2) VLAC accreditation: Lab. code: VLAC-013

Site name	Radiated emission	Conducted emission for mains port	Conducted emission for telecom port	Radiated emission (CMAD)	Expiry Date
3m Semi-anechoic chamber	VLAC-013	-	-	-	Jul. 3, 2015
10m Semi-anechoic chamber				VLAC-013	
Shielded room No.1	-	VLAC-013	-	-	

3) FCC filing:

Site name	Registration Number	Expiry Date
Site 2	91065	Oct.31, 2014
Site 3		
3m Semi-anechoic chamber	540072	Jan. 9, 2016
10m Semi-anechoic chamber		
Shielded room No.1		

4) Industry Canada Oats site filing:

Site name	Sites on file: Oats 3m/10m	Expiry Date
Site 2	4224A-2	Jan. 23, 2015
Site 3	4224A-3	
3m Semi-anechoic chamber	4224A-4	
10m Semi-anechoic chamber	4224A-5	

5) VCCI site filing:

Site name	Radiated emission	Conducted emission for mains port	Conducted emission for telecom port	Expiry Date
Site 2	R-137	C-133	T-1221	Nov. 16, 2014 Nov. 28, 2014* (*:Telecom port)
Site 3	R-138	C-134	T-1222	
3m Semi-anechoic chamber	-	A-0166	-	Jul. 3, 2015
10m Semi-anechoic chamber				
Shielded room No.1				

6) TÜV SÜD PS authorization:

Authorized as an EMC test laboratory

7) TÜV Rheinland authorization:

Authorized as an EMC test laboratory

Appendix A. Test equipment

[Antenna port conducted test]

Equipment	Company	Model No.	Serial No.	Cal. due	Cal. date
Spectrum analyzer	Agilent Technologies	E4440A	US44302655	May 2014	May 14, 2013
Microwave cable	RS	YH_13S5	N/A (S403)	May 2014	May 10, 2013
Attenuator	Weinschel	56-10	J4180	Nov. 2013	Nov. 12, 2012

Radiated emission

Equipment	Company	Model No.	Serial No.	Cal. Due	Cal. Date
EMI Receiver	ROHDE&SCHWARZ	ECSI	100451	Oct. 2013	Oct. 26, 2012
Preamplifier	ANRITSU	MH648A	M96057	Jun. 2014	Jun. 12, 2013
Loop antenna	ROHDE&SCHWARZ	HFH2-Z2	892246/010	Sep. 2014	Sep. 14, 2012
Biconical antenna	Schwarzbeck	VHA9103/BBA9106	2155	May 2014	May 1, 2013
Log periodic antenna	Schwarzbeck	UHALP9108A	0560	May 2014	May 1, 2013
Attenuator	TME	CFA-01NPJ-6	N/A (S275)	Jun. 2014	Jun. 6, 2013
Attenuator	TME	CFA-01NPJ-3	N/A (S272)	Jun. 2014	Jun. 6, 2013
Spectrum analyzer	Agilent Technologies	E4447A	MY46180188	Mar. 2014	Mar. 8, 2013
Preamplifier	Agilent Technologies	8449B	3008A1008	Dec. 2013	Dec. 9, 2012
Double ridged guide antenna	EMCO	3115	4328	Jan. 2014	Jan. 21, 2013
Attenuator	AEROFLEX	40A-03	081217-20	Feb. 2014	Feb. 23, 2013
Broad-Band Horn Antenna	Schwarzbeck	BBHA9170	BBHA9170189	May 2015	May 2, 2013
Preamplifier	TSJ	MLA-1840-B03-35	1240332	May 2015	May 2, 2013
Microwave cable	SUHNER	SUCOFLEX104/9m	346316/4	Oct. 2014	Oct. 6, 2013
		SUCOFLEX104/1m	322084/4	Oct. 2014	Oct. 6, 2013
		SUCOFLEX104/1.5m	317226/4	Oct. 2014	Oct. 6, 2013
		SUCOFLEX104/7m	41625/6	Oct. 2014	Oct. 6, 2013
PC	DELL	DIMENSION E521	75465BX	N/A	N/A
Software	TOYO Corporation	EP5/RE-AJ	0611193/V5.3.61	N/A	N/A
3m Semi-anechoic chamber	TOKIN	N/A	N/A (9002-NSA)	May 2014	May 6, 2013
3m Semi-anechoic chamber	TOKIN	N/A	N/A (9002-SVSWR)	May 2014	May 6, 2013

Conducted emission at mains port

Equipment	Company	Model No.	Serial No.	Cal. due	Cal. date
EMI Receiver	ROHDE&SCHWARZ	ECSI	100451	Oct. 2013	Oct. 26, 2012
Attenuator	HUBER+SUHNER	6810.01.A	N/A (S411)	Feb. 2014	Feb. 28, 2013
Line impedance stabilization network for EUT	Kyoritsu Electrical Works, Ltd.	KNW-407F	8-2003-1	Mar. 2014	Mar. 12, 2013
Coaxial cable	FUJIKURA	5D-2W/4m	N/A (S350)	Feb. 2014	Feb. 4, 2013
Coaxial cable	FUJIKURA	5D-2W/1m	N/A (S193)	Feb. 2014	Feb. 4, 2013
Coaxial cable	SUHNER	RG214/U/10m	N/A (S194)	Feb. 2014	Feb. 4, 2013
PC	DELL	DIMENSION	75465BX	N/A	N/A
Software	TOYO Corporation	EP5/CE-AJ	0611193/V5.2.41	N/A	N/A