



Zacta

TEST REPORT

Report number : Z071C-13395

Issue date : October 25, 2013

The device, as described herewith, was tested pursuant to applicable test procedure and complies with the requirements of;

FCC Part24 Subpart E

The test results are traceable to the international or national standards.

Applicant	:	KYOCERA Corporation
Equipment under test (EUT)	:	Mobile Phone
Model number	:	KYY08
FCC ID	:	JOYKYY08

Date of test : October 7, 9, 17, 2013
Test place : TÜV SÜD Zacta Ltd. Yonezawa Testing Center
4149-7 Hachimanpara 5-chome
Yonezawa-shi Yamagata 992-1128 Japan
Phone: +81-238-28-2880 Fax: +81-238-28-2888
Test results : Complied

The results in this report are applicable only to the equipment tested.
This report shall not be re-produced except in full without the written approval of TÜV SÜD Zacta Ltd.
This test report must not be used by client to claim product certification, approval, or endorsement by NVLAP, NIST, or any agency of the federal government.

Tested by :

Chiaki Kanno

Authorized by :

Eiji Akiba

Deputy General Manager of EMC Technical Department



Table of contents

	Page
1. Summary of Test	4
1.1 Purpose of test	4
1.2 Standards	4
1.3 List of applied test to the EUT	4
1.4 Modification to the EUT by laboratory	4
2. Equipment Under Test	5
2.1 General Description of equipment	5
2.2 EUT information	5
2.3 Variation of the family model(s)	6
2.4 Description of Test mode	6
3. Configuration of equipment	7
3.1 Equipment(s) used	7
3.2 System configuration	7
4. Conducted Output Power	8
4.1 Measurement procedure	8
4.2 Measurement result	8
5. Equivalent Isotropic Radiated Power	9
5.1 Measurement procedure	9
5.2 Calculation method	9
5.3 Limit	9
5.4 Test data	10
6. Peak to Average Ratio	11
6.1 Measurement procedure	11
6.2 Limit	11
6.3 Measurement result	11
6.4 Trace data	12
7. Occupied Bandwidth	13
7.1 Measurement procedure	13
7.2 Limit	13
7.3 Measurement result	13
7.4 Trace data	14
8. Band Edge Spurious and Harmonic at Antenna Terminals	15
8.1 Measurement procedure	15
8.2 Limit	15
8.3 Measurement result	15
8.4 Trace data	16
9. Radiated Emissions and Harmonic Emissions	20
9.1 Measurement procedure	20
9.2 Calculation method	20
9.3 Limit	20
9.4 Test data	21
10. Frequency Stability	22
10.1 Measurement procedure	22



Zacta

10.2 Limit.....	22
10.3 Measurement result.....	23
11. Uncertainty of measurement	24
12. Laboratory description	25
Appendix A. Test equipment	26

1. Summary of Test

1.1 Purpose of test

It is the original test in order to verify conformance to FCC Part 24 Subpart E.

1.2 Standards

CFR47 FCC Part 24 Subpart E

1.2.1 Test Methods

ANSI/TIA/EIA-603-C-2004

1.2.2 Deviation from standards

None

1.3 List of applied test to the EUT

Test items Section	Test items	Condition	Result
2.1046	Conducted Output Power	Conducted	PASS
24.232(c)	Effective Radiated Power Equivalent Isotropic Radiated Power	Radiated	PASS
24.232(d)	Peak to Average Ratio	Conducted	PASS
24.238(a) 2.1049	Occupied Bandwidth	Conducted	PASS
24.238(a) 2.1051	Band Edge Spurious and Harmonic at Antenna Terminal	Conducted	PASS
24.238(a) 2.1053	Radiated emissions and Harmonic Emissions	Radiated	PASS
24.235 2.1055	Frequency Stability	Conducted	PASS

1.3.1 Test set up

Table-Top

1.4 Modification to the EUT by laboratory

None



Zacta

2. Equipment Under Test

2.1 General Description of equipment

EUT is the Mobile Phone.

2.2 EUT information

Applicant : KYOCERA Corporation
Yokohama Office 2-1-1 Kagahara, Tsuzuki-ku Yokohama-shi, Kanagawa,
Japan
Phone: +81-45-943-6253 Fax: +81-45-943-6314

Equipment under test : Mobile Phone

Trade name : Kyocera

Model number : KYY08

Serial number : N/A

EUT condition : Pre-Production

Max. frequency : 1GHz

Power ratings : Battery: DC 3.7V

Size : (W) 49 × (D) 16.5 × (H) 112 mm

Environment : Indoor and Outdoor use

Terminal limitation : -20°C to 60°C

RF Specification
<GSM>

Equipment type : Transceiver

Frequency of Operation : Up Link: 1850.2-1909.8MHz
Down Link: 1930.2-1989.8MHz

Modulation type : GMSK

Emission designator : 246KGXW

Output power : 1.047W EIRP (30.2dBm)

Antenna type : Internal antenna

Antenna gain : 0dBi

2.3 Variation of the family model(s)

Not applicable

2.4 Description of Test mode

The EUT had been tested under operating condition.
There are three channels have been tested as following:

Band	Channel	Frequency
GSM1900	512	1850.2MHz
	661	1880.0MHz
	810	1909.8MHz

The field strength of spurious emissions was measured at each position of all three axis X, Y and Z to compare the level, and the maximum noise.

The worst emission was found in Y axis and the worst case recorded.



Zacta

3. Configuration of equipment

3.1 Equipment(s) used

No.	Equipment	Company	Model No.	Serial No.	FCC ID / DoC	Comment
1	Mobile Phone	KYOCERA	KYY08	N/A	JOYKYY08	EUT

3.2 System configuration

1. Mobile Phone
(EUT)

Note1: Numbers assigned to equipment or cables on this diagram correspond to the list in "3.1 Equipment(s) used".

4. Conducted Output Power

4.1 Measurement procedure [FCC 2.1046]

The conducted output power was measured with a wireless communication tester connected to the antenna terminal. The wireless communication tester parameters were set to produce the maximum power from the EUT.

- Test configuration

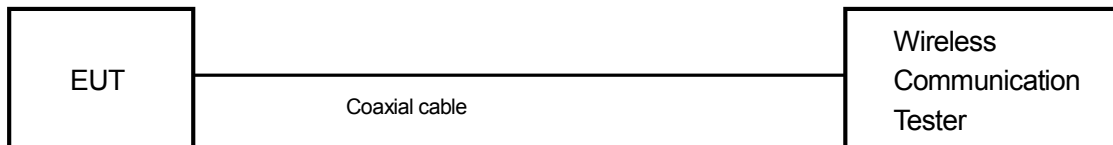

4.2 Measurement result

Date : Oct. 7, 2013
 Temperature : 26.0 [°C]
 Humidity : 58.0 [%]
 Test place : Shielded room

Test personnel :

Tested by :

Chiaki Kanno

Band	Channel	Frequency (MHz)	Test Result (dBm)		
			GSM	GPRS 1 TX Slot	GPRS 2 TX Slot
PCS	512	1850.2	29.36	29.16	27.78
	661	1880.0	29.44	29.31	27.81
	810	1909.8	29.54	29.11	27.83

5. Equivalent Isotropic Radiated Power

5.1 Measurement procedure [FCC 24.232(c)]

<Step 1>

The EUT and support equipment are placed on a 1 meter x 1.5 meter surface, 0.8 meter height FRP table. Radiated emission measurements are performed at 3 meter distance with the broadband antenna (double ridged guide antenna). The antenna is positioned both the horizontal and vertical planes of polarization and height is varied 1 to 4 meters and stopped at height producing the maximum emission. The bandwidth of the spectrum analyzer is set to 1MHz. The turntable is rotated by 360 degrees and stopped at azimuth of producing the maximum emission.

<Step 2>

The substitution antenna is replaced by the transmitter antenna (EUT). The frequency of the signal generator is adjusted to the measurement frequency. Level of the signal generator is adjusted to the level that is obtained from step 1, and record the emission level of signal generator.

- Test configuration

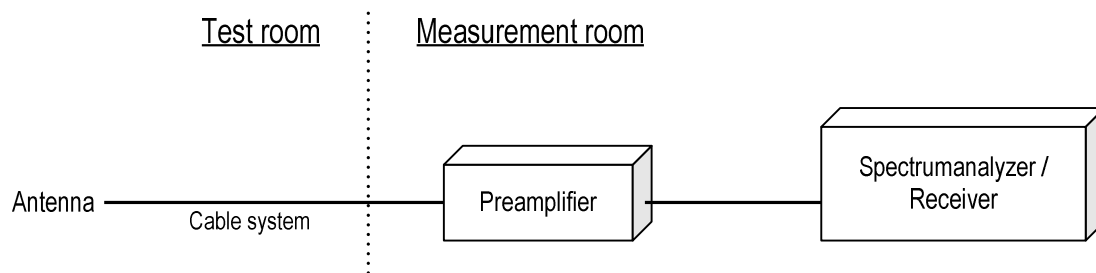

5.2 Calculation method

Result (EIRP) = S.G Reading – Cable loss + Antenna Gain

Margin = Limit – Result (EIRP)

5.3 Limit

2 W (33dBm)



Zacta

5.4 Test data

Date : Oct. 9, 2013
 Temperature : 22.0 [°C]
 Humidity : 57.0 [%]
 Test place : 3m Semi-anechoic chamber

Test personnel :
 Tested by : Chiaki kanno

H/V	Frequency [MHz]	S.A Reading [dBm]	S.G Reading [dBm]	Cable loss [dB]	Ant.Gain [dBi]	Result [dBm]	Limit [dBm]	Margin [dB]
H	1850.2	18.5	23.3	1.1	5.9	28.1	33.0	4.9
H	1880.0	18.9	25.3	1.1	6.0	30.2	33.0	2.8
H	1909.8	18.7	24.8	1.1	6.1	29.8	33.0	3.2

6. Peak to Average Ratio

6.1 Measurement procedure

[FCC 24.232(d)]

The peak to average ratio was measured with a spectrum analyzer connected to the antenna terminal.

The spectrum analyzer is set to;

- RBW=1MHz, VBW=3MHz, Span=5MHz, Sweep=auto, Detector=Peak/average, Trace mode=Max hold

- Test configuration

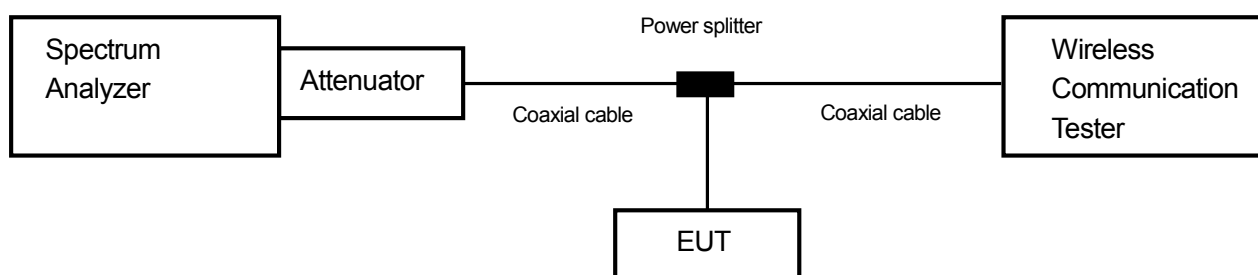

6.2 Limit

13dB or less

6.3 Measurement result

Date : Oct. 7, 2013
 Temperature : 26.0 [°C]
 Humidity : 58.0 [%]
 Test place : Shielded room

Test personnel :

Tested by :

Chiaki Kanno

Mode	Channel	Frequency [MHz]	Peak to Average Power Ratio [dB]	Limit [dB]
GSM1900	661	1880	0.01	13



Zacta

6.4 Trace data [GSM 1900]

Channel: 661

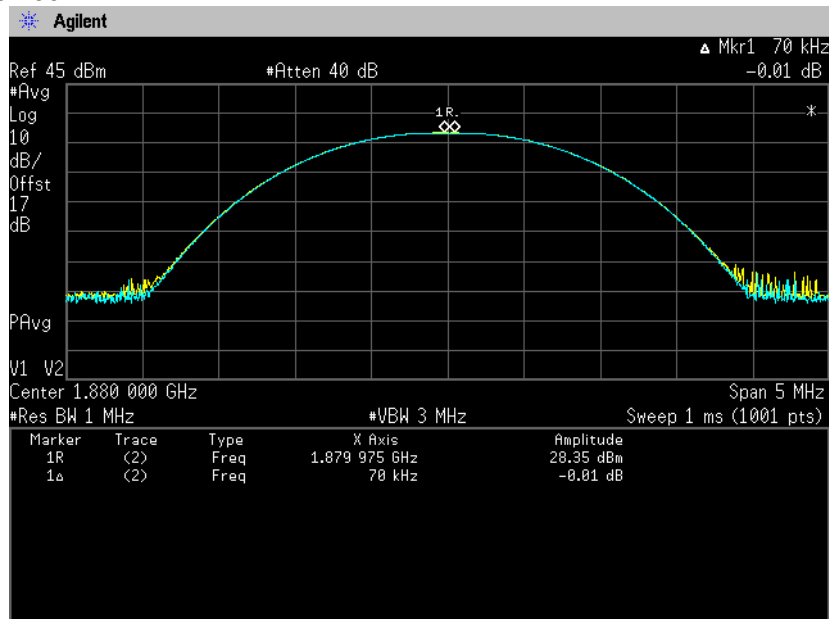

7. Occupied Bandwidth

7.1 Measurement procedure

[FCC 24.238(a), 2.1049]

The Occupied bandwidth was measured with a spectrum analyzer connected to the antenna terminal.

The spectrum analyzer is set to;

- RBW=3kHz, VBW=9.1kHz, Span=1MHz, Sweep=auto, Detector=Peak, Trace mode=Max hold

- Test configuration

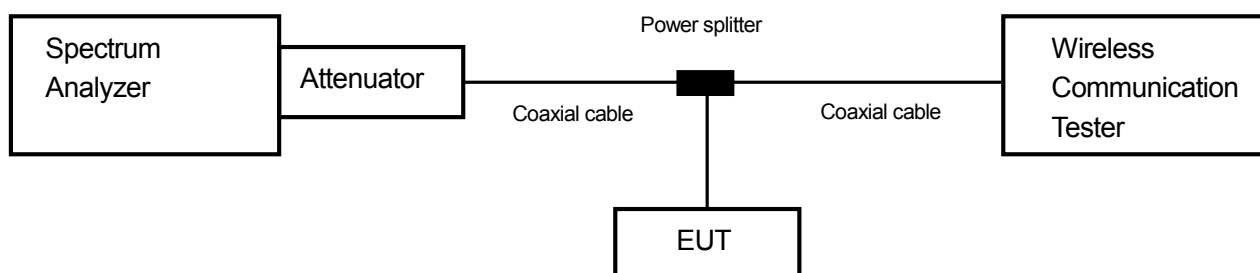

7.2 Limit

None

7.3 Measurement result

Date : Oct. 7, 2013
 Temperature : 26.0 [°C]
 Humidity : 58.0 [%]
 Test place : Shielded room

Test personnel :

Tested by :

Chiaki Kanno

Band	Channel	Frequency (MHz)	Test Result (kHz)
GSM1900	512	1850.2	243.9259
	661	1880.0	244.3575
	810	1909.8	245.7419



Zacta

7.4 Trace data
[GSM 1900]

Channel: 512

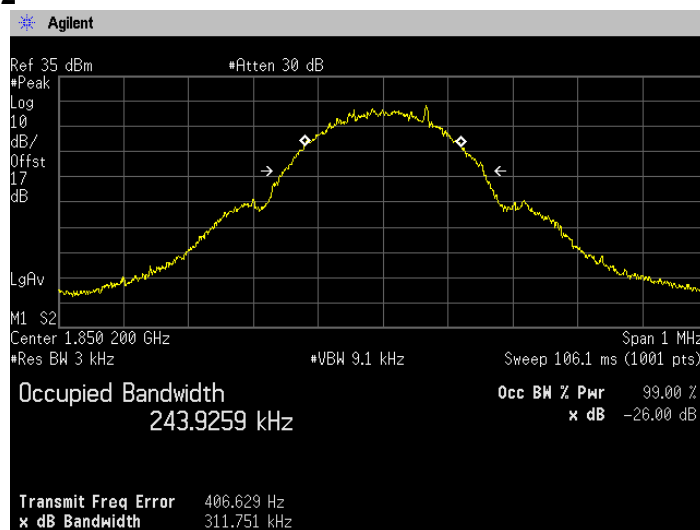

Channel: 661

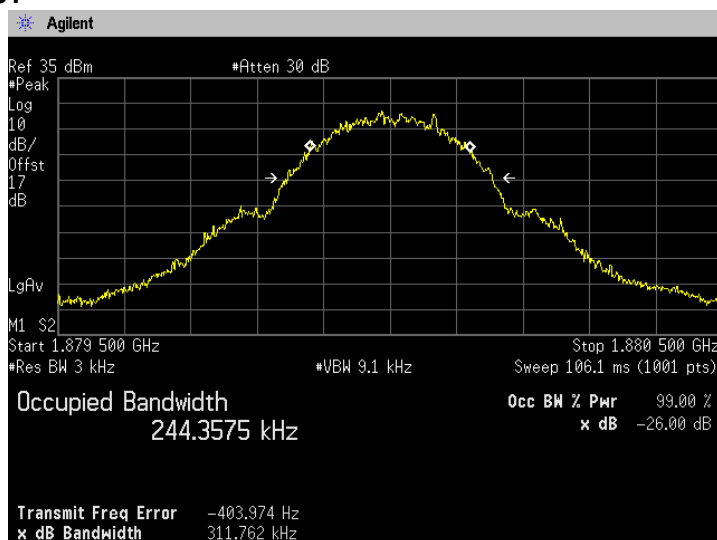

Channel: 810

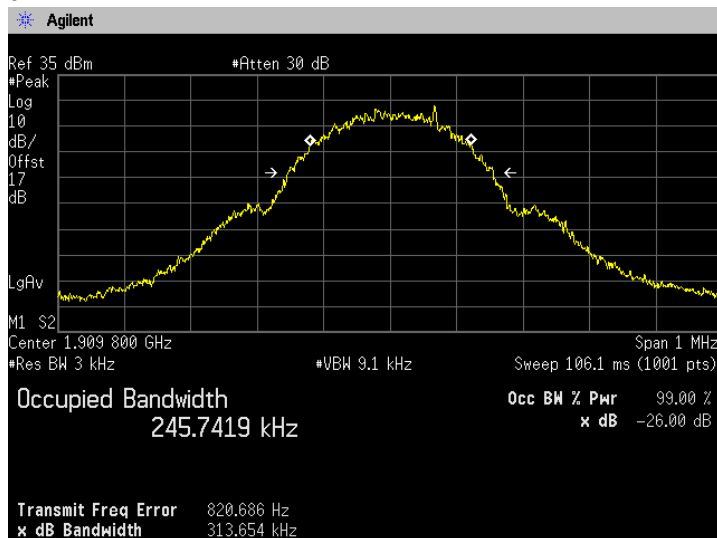

8. Band Edge Spurious and Harmonic at Antenna Terminals

8.1 Measurement procedure

[FCC 24.238(a), 2.1051]

The band edge spurious and harmonic was measured with a spectrum analyzer connected to the antenna terminal.

The spectrum analyzer is set to;

<Band Edge>

- RBW=3kHz, VBW=9.1kHz, Span=1MHz, Sweep=auto, Detector=Peak, Trace mode=Max hold

<Spurious Emissions>

- RBW=1MHz, VBW=3MHz, Span=Arbitrary setting, Sweep=auto, Detector=Peak, Trace mode=Max hold

- Test configuration

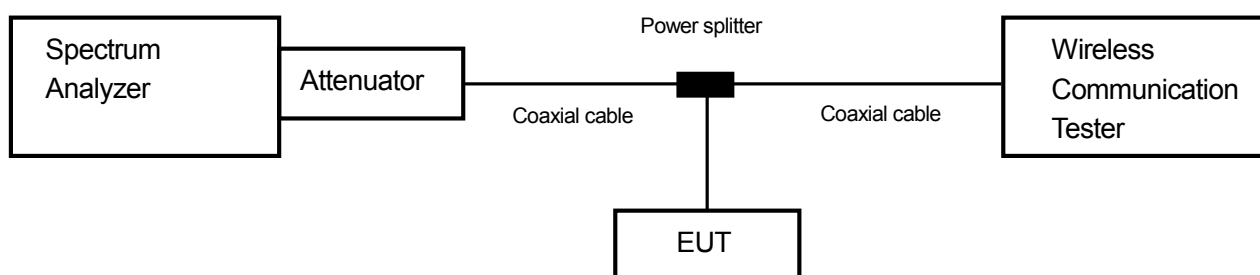

8.2 Limit

-13dBm or less

8.3 Measurement result

Date : Oct. 7, 2013
 Temperature : 26.0 [°C]
 Humidity : 58.0 [%]
 Test place : Shielded room

Test personnel :

Tested by :

Chiaki Kanno

Band	Channel	Frequency [MHz]	Limit [dB]	Results	Results
GSM 1900	512	1850.2	-13	See the trace data	PASS
	661	1880.0	-13	See the trace data	PASS
	810	1909.8	-13	See the trace data	PASS



Zacta

8.4 Trace data [GSM 1900] (Band Edge)

Channel: 512

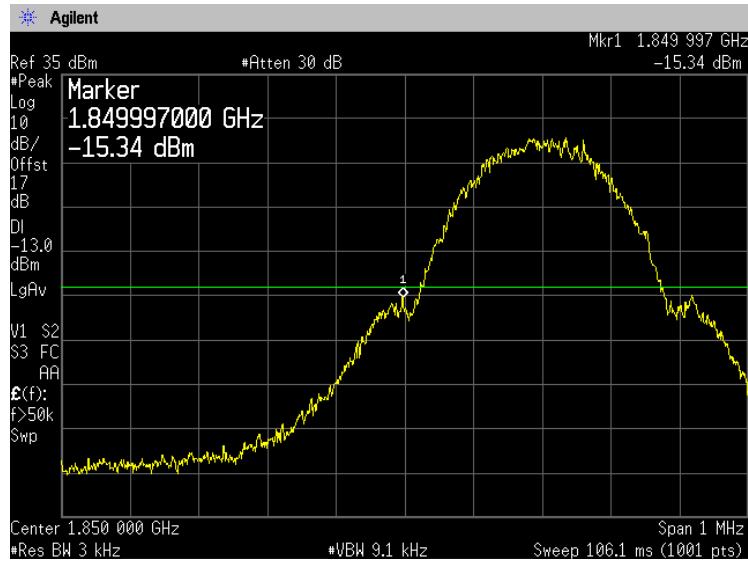

Channel: 810

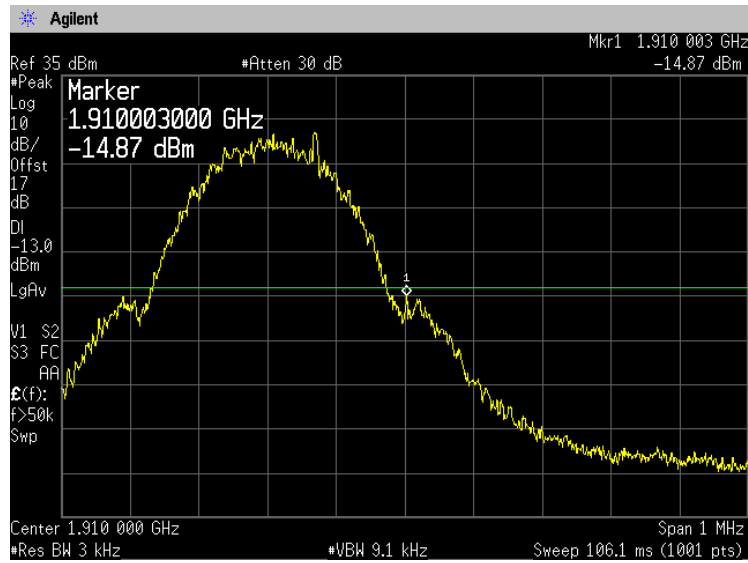



Zacta

(Spurious Emissions)

Channel: 512

30MHz-5GHz

5GHz-10GHz

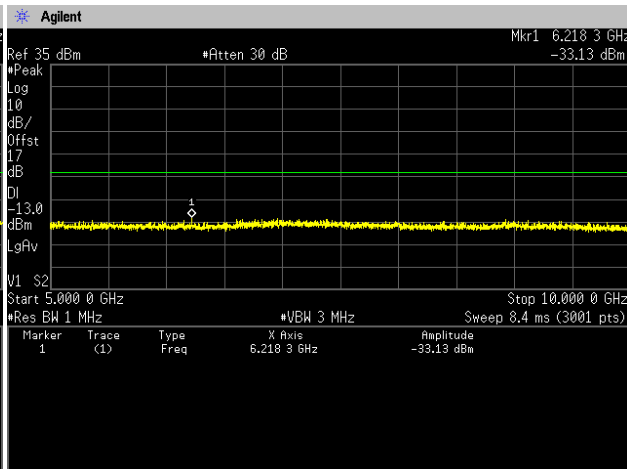
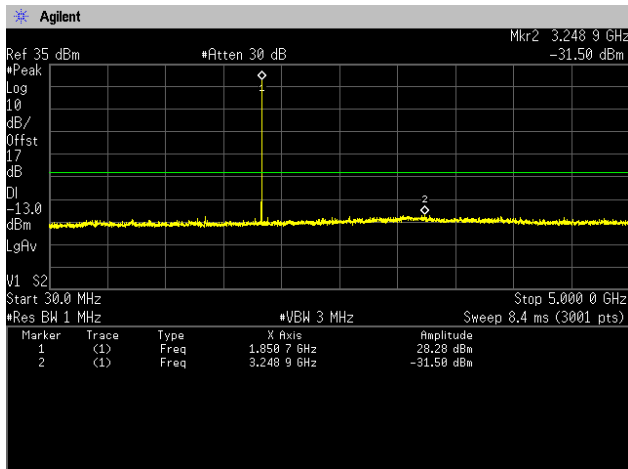

10GHz-15GHz

15GHz-20GHz

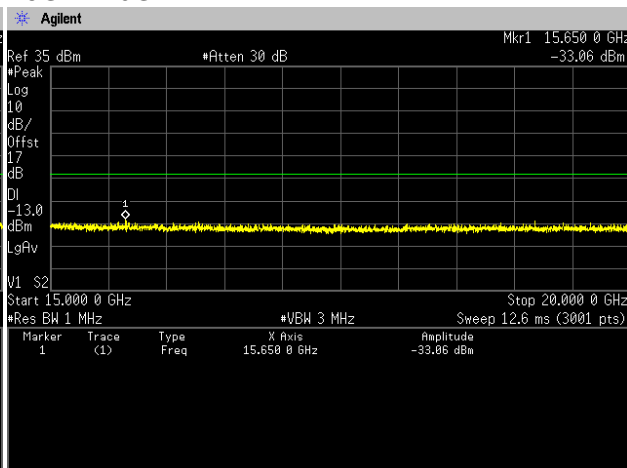
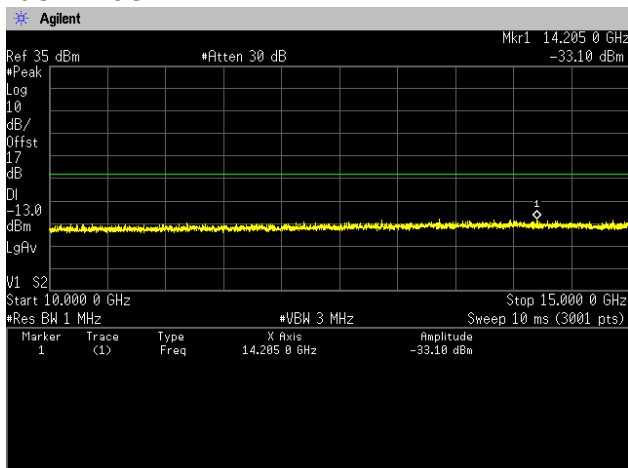



Zacta

**Channel: 661
30MHz-5GHz**

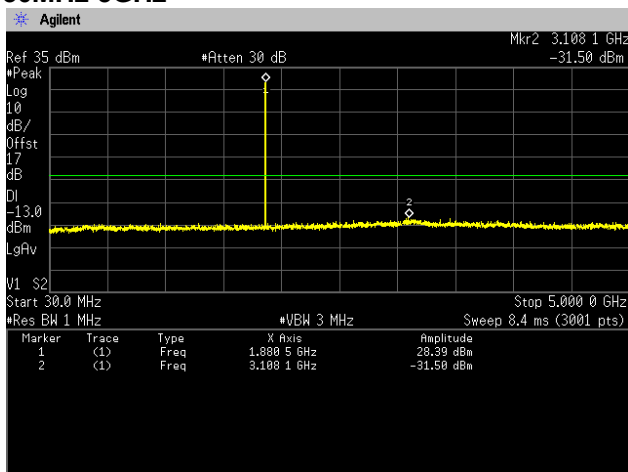

5GHz-10GHz

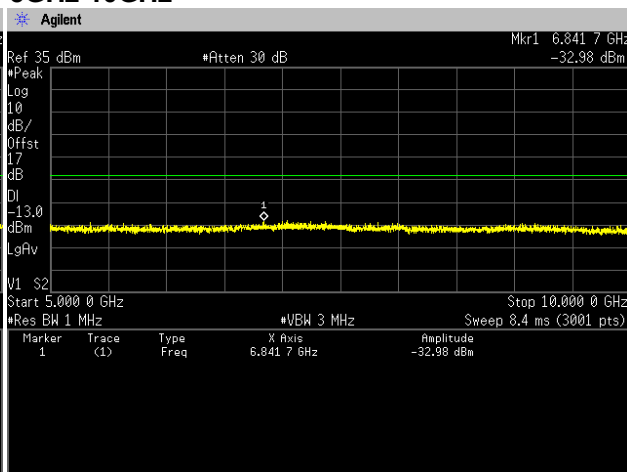

10GHz-15GHz

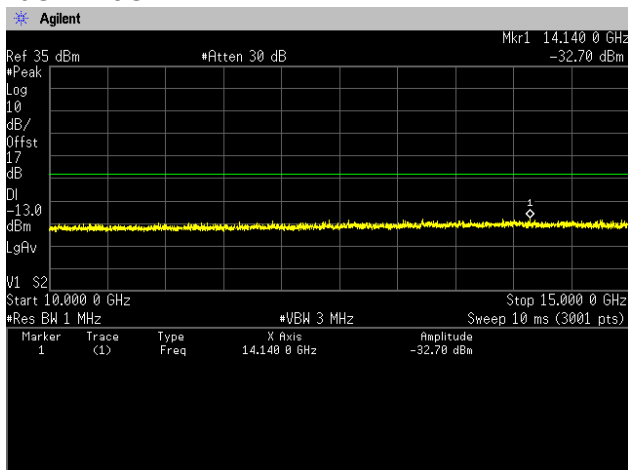

15GHz-20GHz

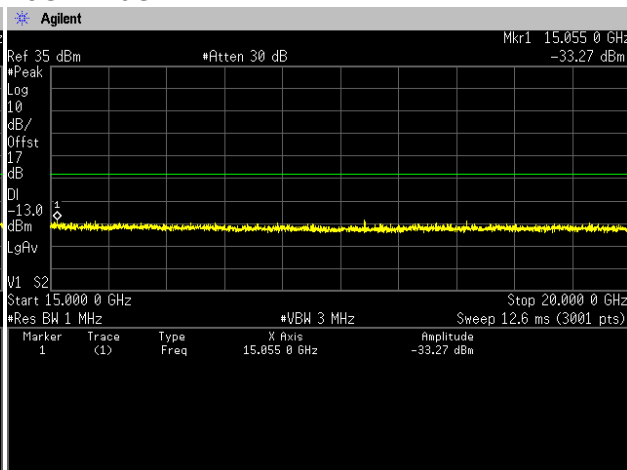



Zacta

Channel: 810
30MHz-5GHz

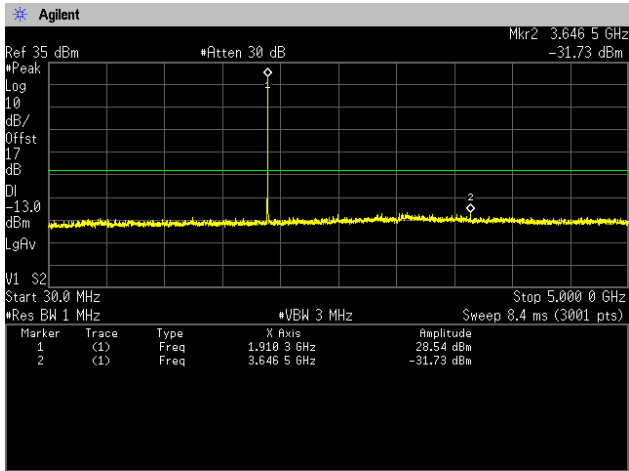

5GHz-10GHz

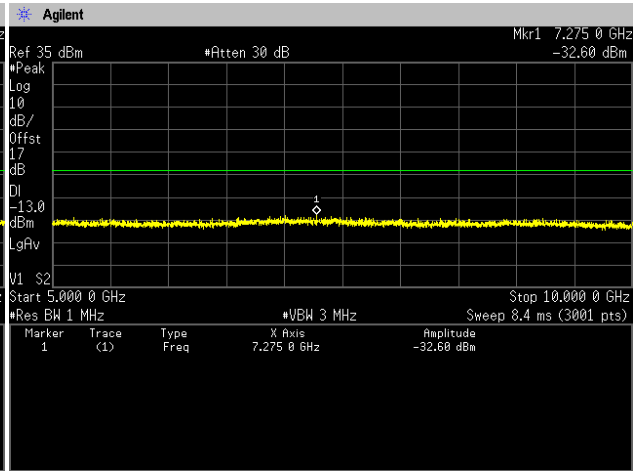

10GHz-15GHz

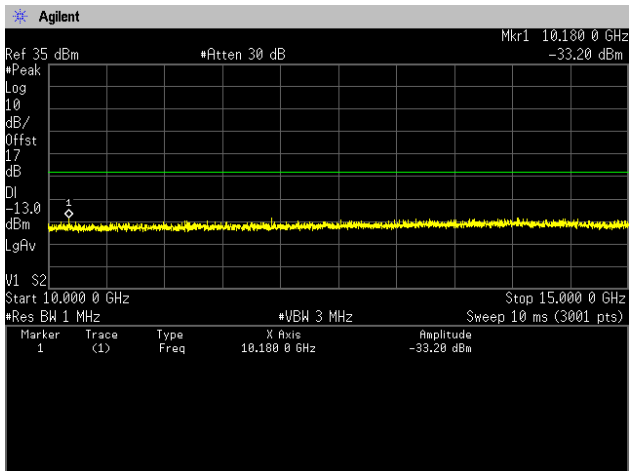

15GHz-20GHz

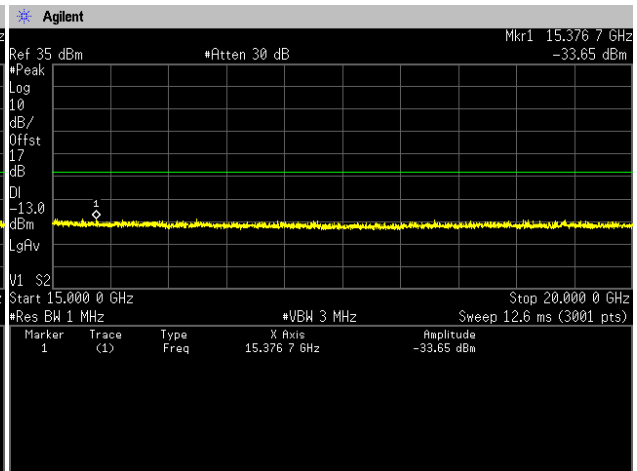

9. Radiated Emissions and Harmonic Emissions

9.1 Measurement procedure [FCC 24.238(a), 2.1053]

<Step 1>

The EUT and support equipment are placed on a 1 meter x 1.5 meter surface, 0.8 meter height FRP table. Radiated emission measurements are performed at 3 meter distance with the broadband antenna (Biconical antenna, Log periodic antenna and double ridged guide antenna). The antenna is positioned both the horizontal and vertical planes of polarization and height is varied 1 to 4 meters and stopped at height producing the maximum emission.

The bandwidth of the spectrum analyzer is set to 1MHz. The turntable is rotated by 360 degrees and stopped at azimuth of producing the maximum emission. The frequency is investigated up to 20GHz.

<Step 2>

The substitution antenna is replaced by the transmitter antenna (EUT).

The frequency of the signal generator is adjusted to the measurement frequency.

Level of the signal generator is adjusted to the level that is obtained from step 1, and record the emission level of signal generator.

- Test configuration

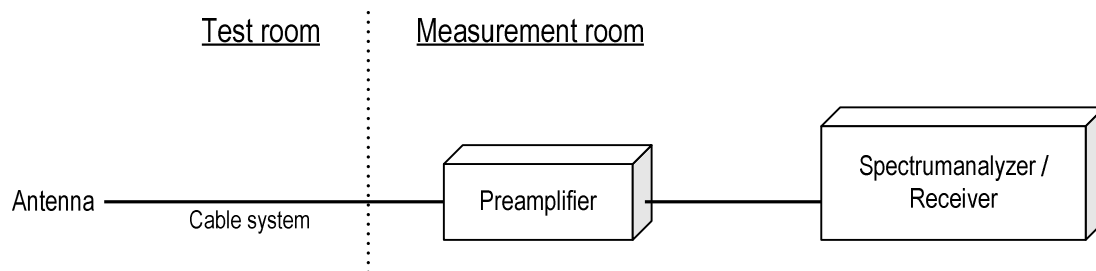

9.2 Calculation method

Result = S.G Reading – Cable loss + Antenna Gain

Margin = Limit – Result (EIRP)

9.3 Limit

-13dBm or less

9.4 Test data

Date : Oct. 9, 2013 Test personnel :
 Temperature : 22.0 [°C]
 Humidity : 57.0 [%] Tested by :
 Test place : 3m Semi-anechoic chamber Chiaki Kanno

[GSM 1900] (Channel: 512)

H/V	Frequency [MHz]	S.A Reading [dBm]	S.G Reading [dBm]	Cable loss [dB]	Ant.Gain [dBi]	Result [dBm]	Limit [dBm]	Margin [dB]
H	3700.4	-47.0	-39.3	1.6	7.2	-33.7	-13.0	20.7
V	3700.4	-46.8	-37.8	1.6	7.2	-32.2	-13.0	19.2
H	5550.0	-48.5	-35.0	1.9	8.8	-28.2	-13.0	15.2
V	5550.0	-47.8	-35.1	1.9	8.8	-28.3	-13.0	15.3

(Channel: 661)

H/V	Frequency [MHz]	S.A Reading [dBm]	S.G Reading [dBm]	Cable loss [dB]	Ant.Gain [dBi]	Result [dBm]	Limit [dBm]	Margin [dB]
H	3760.0	-47.6	-39.6	1.6	7.1	-34.1	-13.0	21.1
V	3760.0	-47.3	-37.8	1.6	7.1	-32.3	-13.0	19.3
H	5640.0	-47.7	-34.7	2.0	9.1	-27.6	-13.0	14.6
V	5640.0	-47.1	-35.3	2.0	9.1	-28.2	-13.0	15.2

(Channel: 810)

H/V	Frequency [MHz]	S.A Reading [dBm]	S.G Reading [dBm]	Cable loss [dB]	Ant.Gain [dBi]	Result [dBm]	Limit [dBm]	Margin [dB]
H	3820.0	-47.3	-36.0	1.6	7.0	-30.6	-13.0	17.6
V	3820.0	-47.0	-36.4	1.6	7.0	-31.0	-13.0	18.0
H	5729.0	-48.4	-35.9	2.0	9.4	-28.5	-13.0	15.5
V	5729.0	-47.8	-36.5	2.0	9.4	-29.1	-13.0	16.1

Note: No emission were detected in frequency range 30MHz to 1000MHz at the 3 meters distance.

10. Frequency Stability

10.1 Measurement procedure [FCC 24.235, 2.1055]

The EUT was placed inside of a constant temperature chamber as the temperature in the chamber was varied between -30°C and $+50^{\circ}\text{C}$. The temperature was incremented by 10°C intervals and the unit was allowed to stabilize at each measurement. The frequency drift was measured with the normal Temperature and voltage tolerance and it is presented as the ppm unit.

- Test configuration

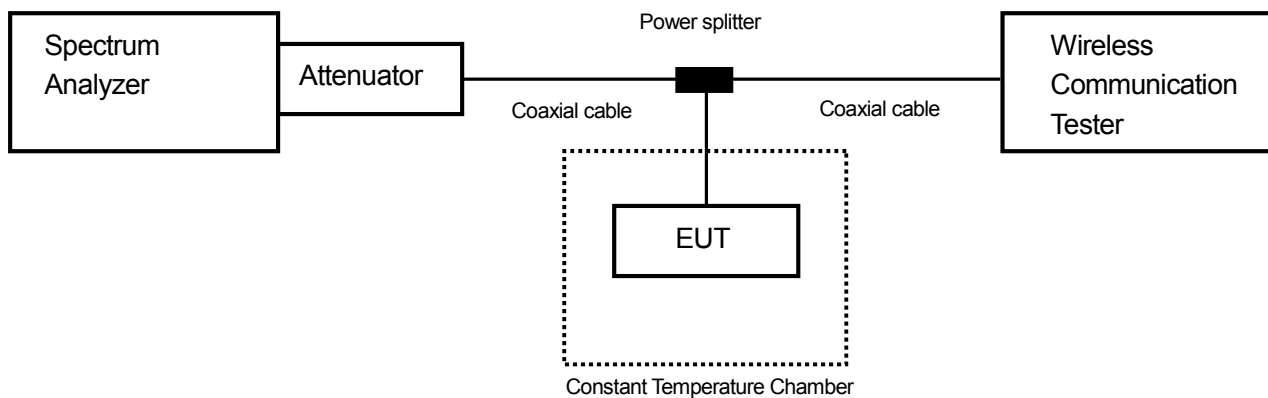

10.2 Limit

$\pm 2.5\text{ppm}$



Zacta

10.3 Measurement result

Date : Oct. 17, 2013
 Temperature : 23.0 [°C]
 Humidity : 62.0 [%]
 Test place : Shielded room

Test personnel

Tested by :

Chiaki Kanno

[GSM 1900]

(Channel: 661)

Limit: $\pm 0.00025\% = \pm 2.5\text{ppm}$					
Power Supply [V]	Temperature [°C]	Measurements Frequency [Hz]	Frequency Tolerance [ppm]	Limit [ppm]	Result
3.70	25(Ref.)	1,879,999,930	0.00000	± 2.5	PASS
	50	1,879,999,922	-0.00431	± 2.5	PASS
	40	1,879,999,932	0.00081	± 2.5	PASS
	30	1,879,999,919	-0.00613	± 2.5	PASS
	20	1,879,999,882	-0.02576	± 2.5	PASS
	10	1,879,999,923	-0.00368	± 2.5	PASS
	0	1,879,999,931	0.00022	± 2.5	PASS
	-10	1,879,999,921	-0.00489	± 2.5	PASS
	-20	1,879,999,920	-0.00555	± 2.5	PASS
	-30	1,879,999,928	-0.00143	± 2.5	PASS
3.145	25	1,879,999,927	-0.00153	± 2.5	PASS
4.255	25	1,879,999,919	-0.00603	± 2.5	PASS

Calculation;

$$\text{Frequency Tolerance (ppm)} = \frac{\text{Measurements Frequency (Hz)} - \text{Reference Frequency (Hz)}}{\text{Reference Frequency (Hz)}} \times 1000000$$

11. Uncertainty of measurement

Expanded uncertainties stated are calculated with a coverage Factor $k=2$.

Please note that these results are not taken into account when determining compliance or non-compliance with test result.

Test item	Measurement uncertainty
Conducted emission at mains port	$\pm 3.0\text{dB}$
Radiated emission (9kHz – 30MHz)	$\pm 4.4\text{dB}$
Radiated emission (30MHz – 1000MHz)	$\pm 4.5\text{dB}$
Radiated emission (1000MHz – 26GHz)	$\pm 3.9\text{dB}$



Zacta

12. Laboratory description

1. Location:

TÜV SÜD Zacta Ltd. Yonezawa Testing Center
 4149-7 Hachimanpara 5-chome Yonezawa-shi Yamagata 992-1128 Japan
 Phone: +81-238-28-2880 Fax: +81-238-28-2888

2. Facility filing information:

1) NVLAP accreditation: NVLAP Lab. code: 200306-0

2) VLAC accreditation: Lab. code: VLAC-013

Site name	Radiated emission	Conducted emission for mains port	Conducted emission for telecom port	Radiated emission (CMAD)	Expiry Date
3m Semi-anechoic chamber	VLAC-013	-	-	-	Jul. 3, 2015
10m Semi-anechoic chamber				VLAC-013	
Shielded room No.1	-	VLAC-013	-	-	

3) FCC filing:

Site name	Registration Number	Expiry Date
Site 2	91065	Oct.31, 2014
Site 3		
3m Semi-anechoic chamber	540072	Jan. 9, 2016
10m Semi-anechoic chamber		
Shielded room No.1		

4) Industry Canada Oats site filing:

Site name	Sites on file: Oats 3m/10m	Expiry Date
Site 2	4224A-2	Jan. 23, 2015
Site 3	4224A-3	
3m Semi-anechoic chamber	4224A-4	
10m Semi-anechoic chamber	4224A-5	

5) VCCI site filing:

Site name	Radiated emission	Conducted emission for mains port	Conducted emission for telecom port	Expiry Date
Site 2	R-137	C-133	T-1221	Nov. 16, 2014 Nov. 28, 2014* (*:Telecom port)
Site 3	R-138	C-134	T-1222	
3m Semi-anechoic chamber	-	A-0166	-	Jul. 3, 2015
10m Semi-anechoic chamber				
Shielded room No.1	-	A-0166	-	

6) TÜV SÜD PS authorization:

Authorized as an EMC test laboratory

7) TÜV Rheinland authorization:

Authorized as an EMC test laboratory

Appendix A. Test equipment

[Antenna port conducted test]

Equipment	Company	Model No.	Serial No.	Cal. due	Cal. date
Spectrum analyzer	Agilent Technologies	E4440A	US44302655	May 2014	May 14, 2013
Microwave cable	RS	YH_13S5	N/A (S403)	May 2014	May 10, 2013
Microwave cable	SUHNER	SUCOFLEX104/1.5m	322086/4	Jul. 2014	Jul. 30, 2013
Microwave cable	SUHNER	SUCOFLEX104/1.5m	322087/4	Jul. 2014	Jul. 30, 2013
Attenuator	Weinschel	56-10	J4180	Nov. 2013	Nov. 12, 2012
Power splitter	ANRITSU	K240B	020205	Nov. 2013	Nov. 12, 2012
Wideband radio frequency tester	ROHDE&SCHWARZ	CMW500	126079	Aug. 2014	Aug. 7, 2013
Operation type temperature controlled bath	Espec	PL3KP	14016727	Dec. 2013	Dec. 27, 2012

Radiated emission

Equipment	Company	Model No.	Serial No.	Cal. Due	Cal. Date
EMI Receiver	ROHDE&SCHWARZ	ECSI	100451	Oct. 2013	Oct. 26, 2012
Preamplifier	ANRITSU	MH648A	M96057	Jun. 2014	Jun. 12, 2013
Biconical antenna	Schwarzbeck	VHA9103/BBA9106	2155	May 2014	May 1, 2013
Log periodic antenna	Schwarzbeck	UHALP9108A	0560	May 2014	May 1, 2013
Attenuator	TME	CFA-01NPJ-6	N/A (S275)	Jun. 2014	Jun. 6, 2013
Attenuator	TME	CFA-01NPJ-3	N/A (S272)	Jun. 2014	Jun. 6, 2013
Spectrum analyzer	Agilent Technologies	E4447A	MY46180188	Mar. 2014	Mar. 8, 2013
Preamplifier	Agilent Technologies	8449B	3008A1008	Dec. 2013	Dec. 9, 2012
Double ridged guide antenna	EMCO	3115	4328	Jan. 2014	Jan. 21, 2013
Attenuator	AEROFLEX	40A-03	081217-20	Feb. 2014	Feb. 23, 2013
Broad-Band Horn Antenna	Schwarzbeck	BBHA9170	BBHA9170189	May 2015	May 2, 2013
Preamplifier	TSJ	MLA-1840-B03-35	1240332	May 2015	May 2, 2013
Dipole antenna	Schwarzbeck	VHAP	1021	Sep. 2014	Sep. 19, 2013
Dipole antenna	Schwarzbeck	UHAP	993	Sep. 2014	Sep. 19, 2013
Double ridged guide antenna	EMCO	3115	00058532	Sep. 2014	Sep. 6, 2013
Signal generator	Agilent Technologies	8648C	3847M00468	Jun. 2014	Jun. 18, 2013
Signal generator	ROHDE&SCHWARZ	SMR27	839256/034	Jan. 2014	Jan. 30, 2013
Microwave cable	SUHNER	SUCOFLEX104/1.5m	322086/4	Jul. 2014	Jul. 30, 2013
Wideband radio frequency tester	ROHDE&SCHWARZ	CMW500	126079	Aug. 2014	Aug. 7, 2013
High pass filter	Wainwright	WHKX2.8/18G-6SS	1	Jul. 2014	Jul. 17, 2013
Microwave cable	SUHNER	SUCOFLEX104/9m	346316/4	Oct. 2014	Oct. 6, 2013
		SUCOFLEX104/1m	322084/4	Oct. 2014	Oct. 6, 2013
		SUCOFLEX104/1.5m	317226/4	Oct. 2014	Oct. 6, 2013
		SUCOFLEX104/7m	41625/6	Oct. 2014	Oct. 6, 2013
PC	DELL	DIMENSION E521	75465BX	N/A	N/A
Software	TOYO Corporation	EP5/RE-AJ	0611193/V5.3.61	N/A	N/A
3m Semi-anechoic chamber	TOKIN	N/A	N/A (9002-NSA)	May 2014	May 6, 2013
3m Semi-anechoic chamber	TOKIN	N/A	N/A (9002-SVSWR)	May 2014	May 6, 2013