



Zacta

TEST REPORT

Report number : Z071C-13394

Issue date : October 25, 2013

The device, as described herewith, was tested pursuant to applicable test procedure and complies with the requirements of;

FCC Part22 Subpart H

The test results are traceable to the international or national standards.

Applicant : KYOCERA Corporation

Equipment under test (EUT) : Mobile Phone

Model number : KYY08

FCC ID : JOYKYY08

Date of test : October 7, 9, 17, 2013

Test place : TÜV SÜD Zacta Ltd. Yonezawa Testing Center
4149-7 Hachimanpara 5-chome
Yonezawa-shi Yamagata 992-1128 Japan
Phone: +81-238-28-2880 Fax: +81-238-28-2888

Test results : Complied

The results in this report are applicable only to the equipment tested.

This report shall not be re-produced except in full without the written approval of TÜV SÜD Zacta Ltd.

This test report must not be used by client to claim product certification, approval, or endorsement by NVLAP, NIST, or any agency of the federal government.

Tested by : Chiaki Kanno
Chiaki Kanno

Authorized by : Eiji Akiba
Eiji Akiba
Deputy General Manager of EMC Technical Department



Table of contents

	Page
1. Summary of Test	3
1.1 Purpose of test	3
1.2 Standards	3
1.3 List of applied test to the EUT	3
1.4 Modification to the EUT by laboratory	3
2. Equipment Under Test	4
2.1 General Description of equipment	4
2.2 EUT information	4
2.3 Variation of the family model(s)	5
2.4 Description of Test mode	5
3. Configuration of equipment	6
3.1 Equipment(s) used	6
3.2 System configuration	6
4. Conducted Output Power	7
4.1 Measurement procedure	7
4.2 Measurement result	7
5. Effective Radiated Power	8
5.1 Measurement procedure	8
5.2 Calculation method	8
5.3 Limit	8
5.4 Test data	9
6. Occupied Bandwidth	10
6.1 Measurement procedure	10
6.2 Limit	10
6.3 Measurement result	10
6.4 Trace data	11
7. Band Edge Spurious and Harmonic at Antenna Terminals	12
7.1 Measurement procedure	12
7.2 Limit	12
7.3 Measurement result	12
7.4 Trace data	13
8. Radiated Emissions and Harmonic Emissions	18
8.1 Measurement procedure	18
8.2 Calculation method	18
8.3 Limit	18
8.4 Test data	19
9. Frequency Stability	20
9.1 Measurement procedure	20
9.2 Limit	20
9.3 Measurement result	21
10. Uncertainty of measurement	22
11. Laboratory description	23
Appendix A. Test equipment	24

1. Summary of Test

1.1 Purpose of test

It is the original test in order to verify conformance to FCC Part 22 Subpart H.

1.2 Standards

CFR47 FCC Part 22 Subpart H

1.2.1 Test Methods

ANSI/TIA/EIA-603-C-2004

1.2.2 Deviation from standards

None

1.3 List of applied test to the EUT

Test items Section	Test items	Condition	Result
2.1046	Conducted Output Power	Conducted	PASS
22.913(a)	Effective Radiated Power	Radiated	PASS
22.917(a) 2.1049	Occupied Bandwidth	Conducted	PASS
22.917(a) 2.1051	Band Edge Spurious and Harmonic at Antenna Terminal	Conducted	PASS
22.917(a) 2.1053	Radiated emissions and Harmonic Emissions	Radiated	PASS
22.355 2.1055	Frequency Stability	Conducted	PASS

1.3.1 Test set up

Table-Top

1.4 Modification to the EUT by laboratory

None



Zacta

2. Equipment Under Test

2.1 General Description of equipment

EUT is the Mobile Phone.

2.2 EUT information

Applicant	:	KYOCERA Corporation Yokohama Office 2-1-1 Kagahara, Tsuzuki-ku Yokohama-shi, Kanagawa, Japan Phone: +81-45-943-6253 Fax: +81-45-943-6314
Equipment under test	:	Mobile Phone
Trade name	:	Kyocera
Model number	:	KYY08
Serial number	:	N/A
EUT condition	:	Pre-Production
Max. frequency	:	1GHz
Power ratings	:	Battery: DC 3.7V
Size	:	(W) 49 × (D) 16.5 × (H) 112 mm
Environment	:	Indoor and Outdoor use
Terminal limitation	:	-20°C to 60°C
RF Specification <CDMA2000>		
Equipment type	:	Transceiver
Frequency of Operation	:	Up Link: 824.70-848.31MHz Down Link: 869.70-893.31MHz
Modulation type	:	QPSK
Emission designator	:	1M28F9W
Output power	:	0.115W EIRP (20.6dBm)
Antenna type	:	Internal antenna
Antenna gain	:	0dBi

2.3 Variation of the family model(s)

Not applicable

2.4 Description of Test mode

The EUT had been tested under operating condition.
There are three channels have been tested as following:

Band	Channel	Frequency
Cellular CDMA	1013	824.70MHz
	384	836.52MHz
	777	848.31MHz

The field strength of spurious emissions was measured at each position of all three axis X, Y and Z to compare the level, and the maximum noise.

The worst emission was found in Z axis and the worst case recorded.



Zacta

3. Configuration of equipment

3.1 Equipment(s) used

No.	Equipment	Company	Model No.	Serial No.	FCC ID / DoC	Comment
1	Mobile Phone	KYOCERA	KYY08	N/A	JOYKYY08	EUT

3.2 System configuration

1. Mobile Phone
(EUT)

Note1: Numbers assigned to equipment on this diagram correspond to the list in "3.1 Equipment(s) used".

4. Conducted Output Power

4.1 Measurement procedure [FCC 2.1046]

The conducted output power was measured with a wireless communication tester connected to the antenna terminal. The wireless communication tester parameters were set to produce the maximum power from the EUT.

- Test configuration

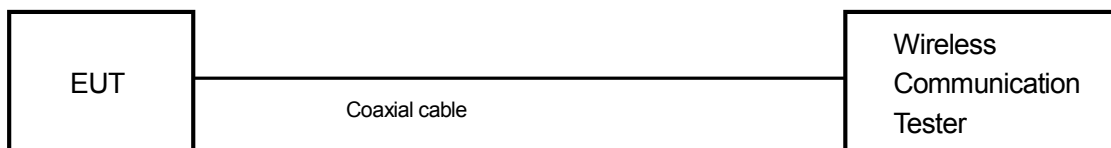

4.2 Measurement result

Date : Oct. 7, 2013
 Temperature : 26.0 [°C]
 Humidity : 58.0 [%]
 Test place : Shielded room

Test personnel :

Tested by :

Chiaki Kanno

Band	Channel	Frequency [MHz]	1X RTT [dBm]							
			RC1	RC3	RC4	RC1	RC3	RC4	RC2	RC5
			SO55	SO55	SO55	SO02	SO02	SO02	SO9	SO9
Cellular CDMA	1013	824.70	23.86	23.83	23.99	23.80	23.91	23.76	23.85	24.07
	384	836.52	23.58	23.72	23.70	23.44	23.57	23.64	23.56	23.59
	777	848.31	23.75	23.81	23.78	23.77	23.66	23.72	23.78	23.87

5. Effective Radiated Power

5.1 Measurement procedure [FCC 22.913(a)]

<Step 1>

The EUT and support equipment are placed on a 1 meter x 1.5 meter surface, 0.8 meter height FRP table. Radiated emission measurements are performed at 3 meter distance with the broadband antenna (double ridged guide antenna). The antenna is positioned both the horizontal and vertical planes of polarization and height is varied 1 to 4 meters and stopped at height producing the maximum emission. The bandwidth of the spectrum analyzer is set to 1MHz. The turntable is rotated by 360 degrees and stopped at azimuth of producing the maximum emission.

<Step 2>

The substitution antenna is replaced by the transmitter antenna (EUT). The frequency of the signal generator is adjusted to the measurement frequency. Level of the signal generator is adjusted to the level that is obtained from step 1, and record the emission level of signal generator.

- Test configuration

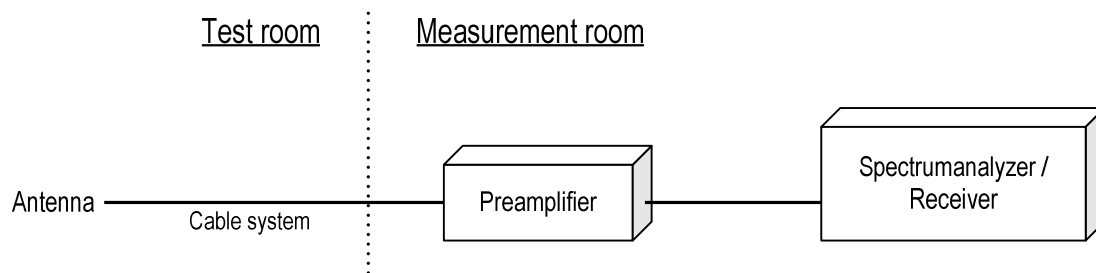

5.2 Calculation method

Result (ERP) = S.G Reading – Cable loss + Antenna Gain
Margin = Limit – Result (ERP)

5.3 Limit

7 W (38.45dBm)



Zacta

5.4 Test data

Date : Oct. 9, 2013
 Temperature : 22.0 [°C]
 Humidity : 57.0 [%]
 Test place : 3m Semi-anechoic chamber

Test personnel :
 Tested by : Chiaki kanno

H/V	Frequency [MHz]	S.A Reading [dBm]	S.G Reading [dBm]	Cable loss [dB]	Ant.Gain [dBi]	Result [dBm]	Limit [dBm]	Margin [dB]
H	824.5	12.4	31.6	0.7	-10.7	20.2	38.5	18.3
H	836.5	12.3	32.0	0.7	-10.7	20.6	38.5	17.9
H	848.3	12.3	31.9	0.7	-10.8	20.4	38.5	18.1

6. Occupied Bandwidth

6.1 Measurement procedure

[FCC 22.917(a), 2.1049]

The Occupied bandwidth was measured with a spectrum analyzer connected to the antenna terminal.

The spectrum analyzer is set to;

- RBW=15kHz, VBW=43kHz, Span=3MHz, Sweep=auto, Detector=Peak, Trace mode=Max hold

- Test configuration

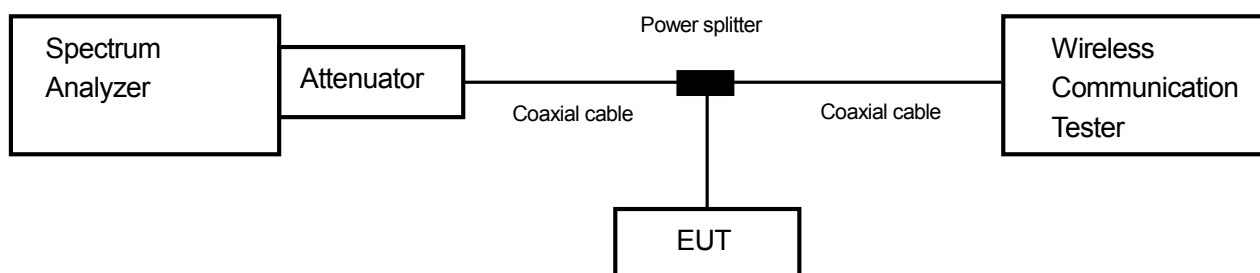

6.2 Limit

None

6.3 Measurement result

Date : Oct. 7, 2013
 Temperature : 26.0 [°C]
 Humidity : 58.0 [%]
 Test place : Shielded room

Test personnel :

Tested by :

Chiaki Kanno

Band	Channel	Frequency (MHz)	Test Result (MHz)
Cellular CDMA	1013	824.70	1.2787
	384	836.52	1.2808
	777	848.31	1.2788



Zacta

6.4 Trace data
[Cellular CDMA]

Channel: 1013

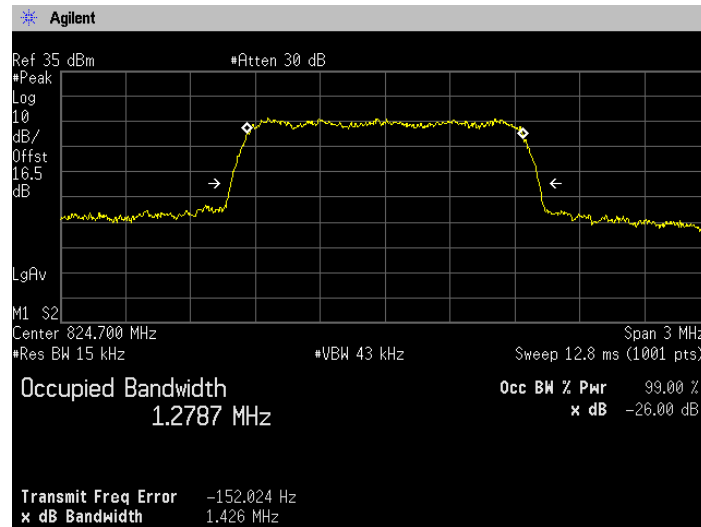

Channel: 384

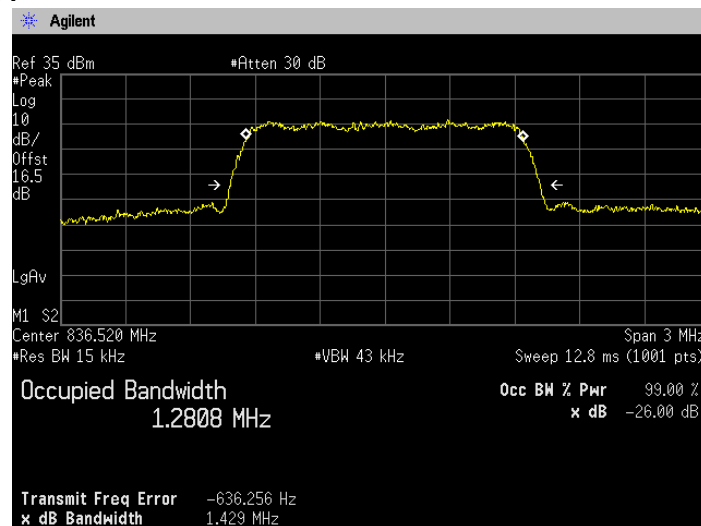

Channel: 777

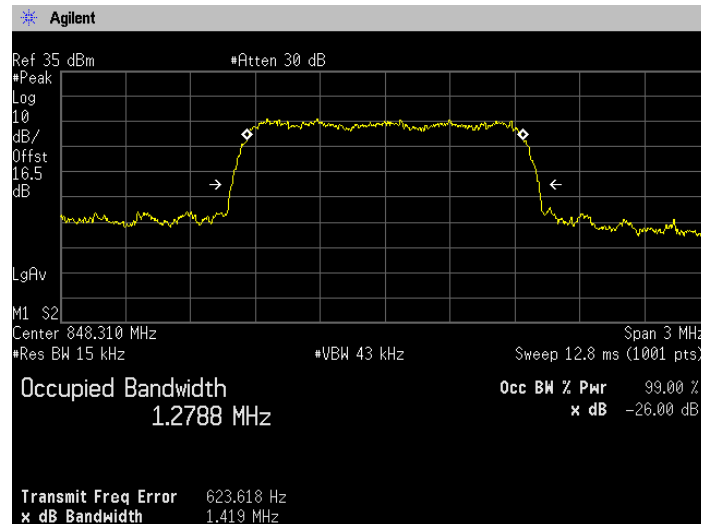

7. Band Edge Spurious and Harmonic at Antenna Terminals

7.1 Measurement procedure [FCC 22.917(a), 2.1051]

The band edge spurious and harmonic was measured with a spectrum analyzer connected to the antenna terminal.

The spectrum analyzer is set to;

<Band Edge>

- RBW=13kHz, 100kHz, VBW=39kHz, 300kHz, Span=400kHz, 4MHz, Sweep=auto, Detector=Average, Trace mode=Max hold

<Spurious Emissions>

- RBW=1MHz, VBW=3MHz, Span=Arbitrary setting, Sweep=auto, Detector=Peak, Trace mode=Max hold

- Test configuration

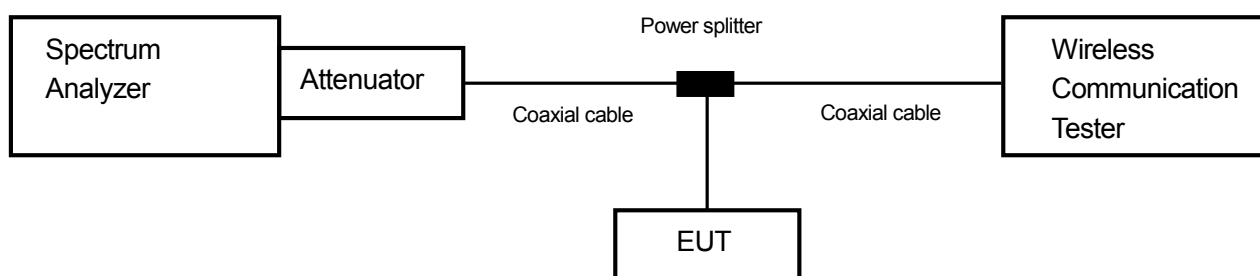

7.2 Limit

-13dBm or less

7.3 Measurement result

Date : Oct. 7 2013
 Temperature : 26.0 [°C]
 Humidity : 58.0 [%]
 Test place : Shielded room

Test personnel :

Tested by :

Chiaki Kanno

Band	Channel	Frequency [MHz]	Limit [dB]	Results	Results
Cellular CDMA	1013	824.70	-13	See the trace data	PASS
	384	836.52	-13	See the trace data	PASS
	777	848.31	-13	See the trace data	PASS



Zacta

7.4 Trace data
[Cellular CDMA]
(Band Edge)

Channel: 1013

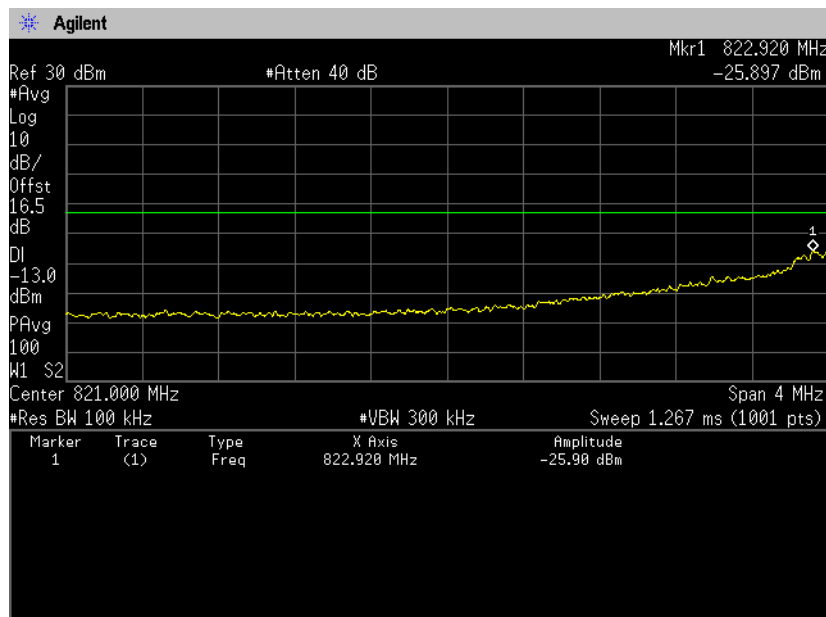
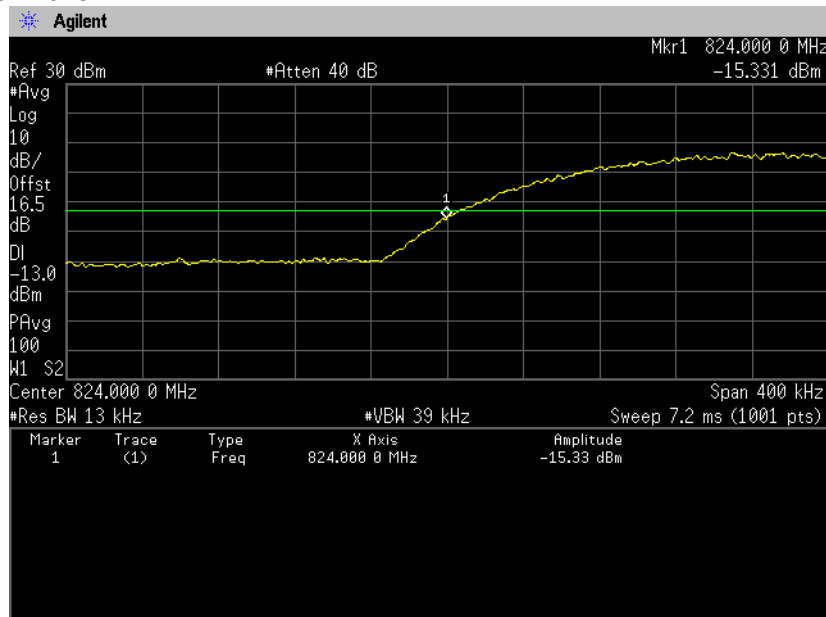

Channel: 777

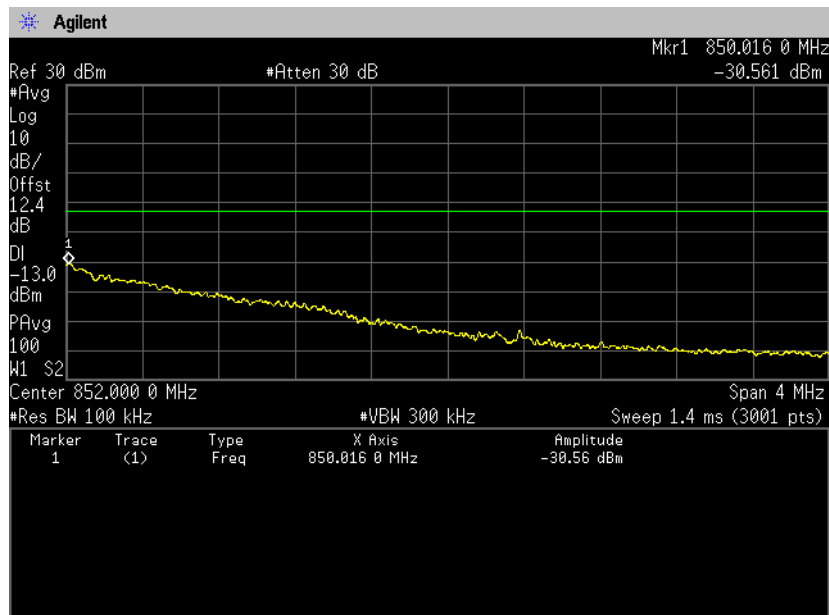
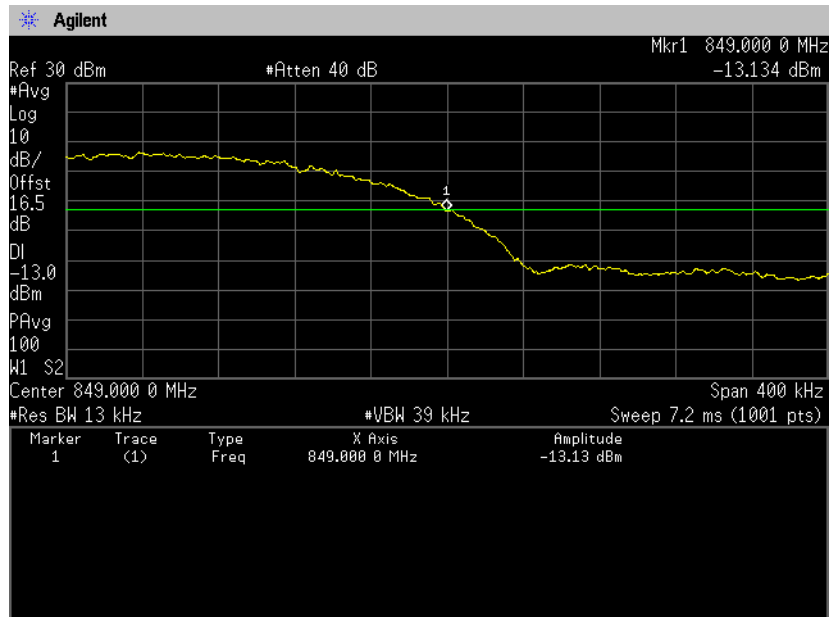



Zacta

(Spurious Emissions)
Channel: 1013
30MHz-5GHz

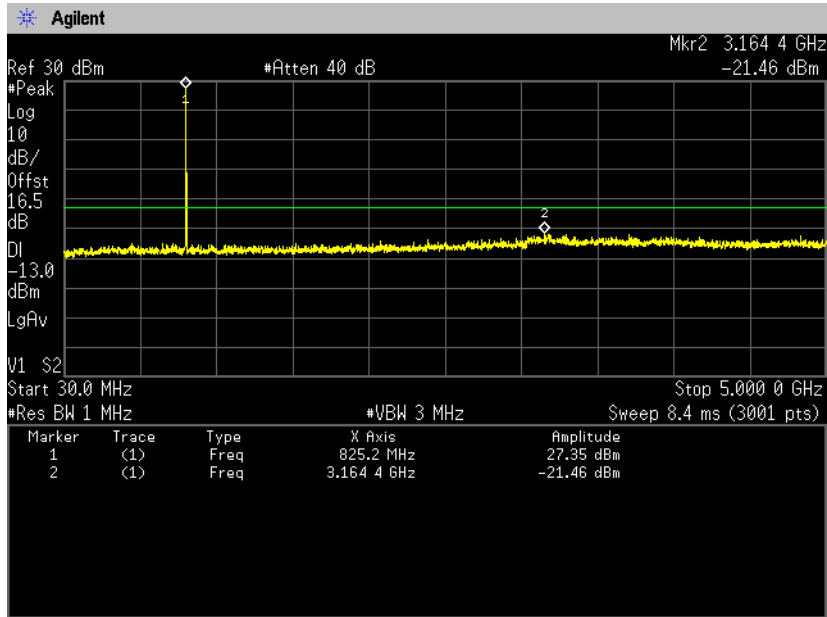

5GHz-10GHz

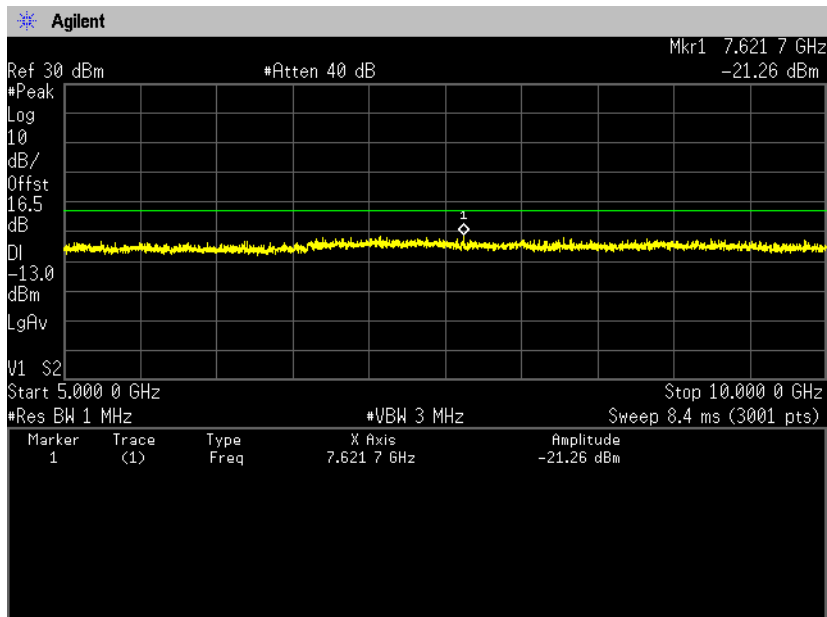



Zacta

**Channel: 384
30MHz-5GHz**

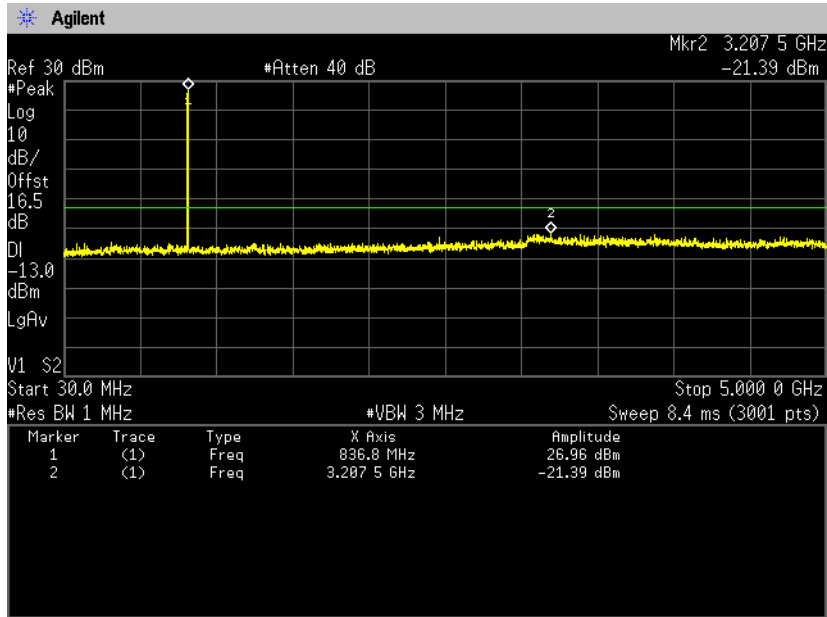

5GHz-10GHz

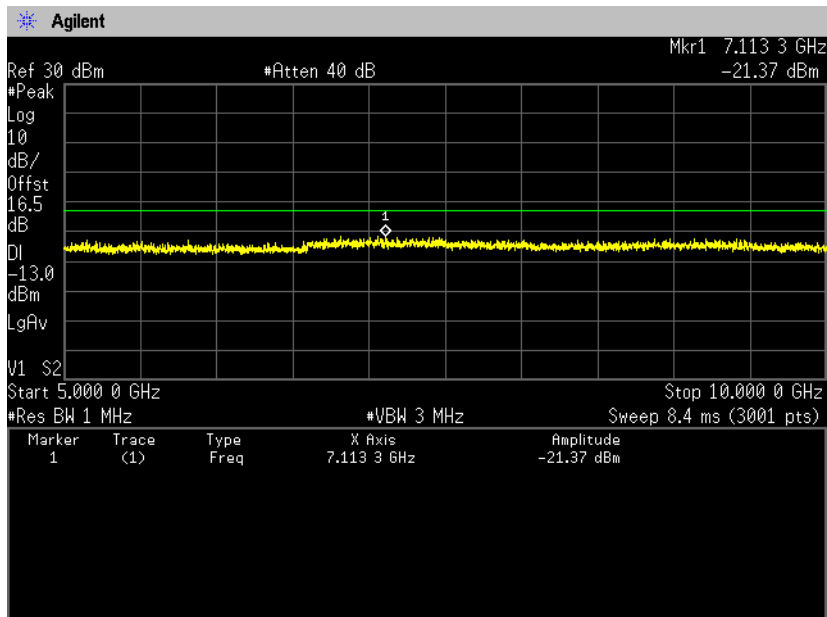



Zacta

**Channel: 777
30MHz-5GHz**

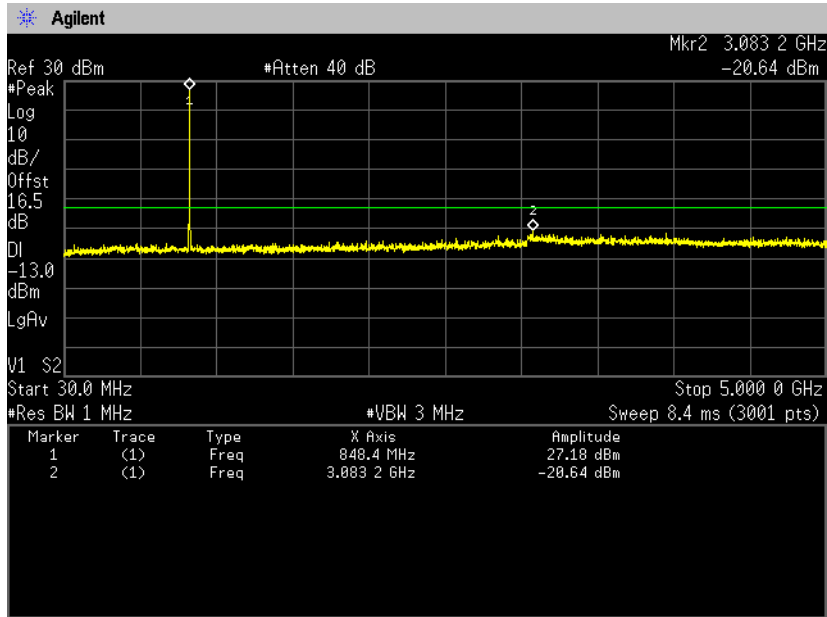

5GHz-10GHz

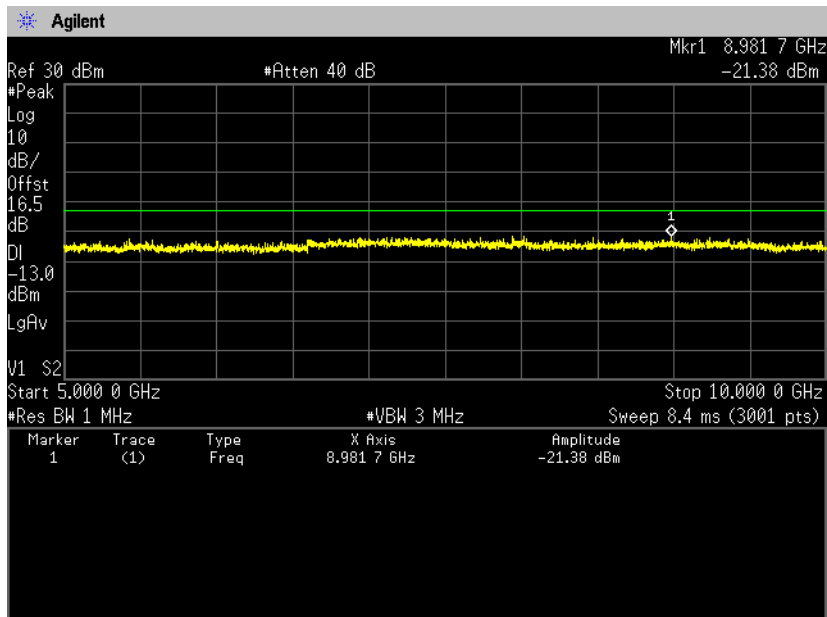

8. Radiated Emissions and Harmonic Emissions

8.1 Measurement procedure [FCC 22.917(a), 2.1053]

<Step 1>

The EUT and support equipment are placed on a 1 meter x 1.5 meter surface, 0.8 meter height FRP table. Radiated emission measurements are performed at 3 meter distance with the broadband antenna (Biconical antenna, Log periodic antenna and double ridged guide antenna). The antenna is positioned both the horizontal and vertical planes of polarization and height is varied 1 to 4 meters and stopped at height producing the maximum emission.

The bandwidth of the spectrum analyzer is set to 1MHz. The turntable is rotated by 360 degrees and stopped at azimuth of producing the maximum emission. The frequency is investigated up to 20GHz.

<Step 2>

The substitution antenna is replaced by the transmitter antenna (EUT).

The frequency of the signal generator is adjusted to the measurement frequency.

Level of the signal generator is adjusted to the level that is obtained from step 1, and record the emission level of signal generator.

- Test configuration

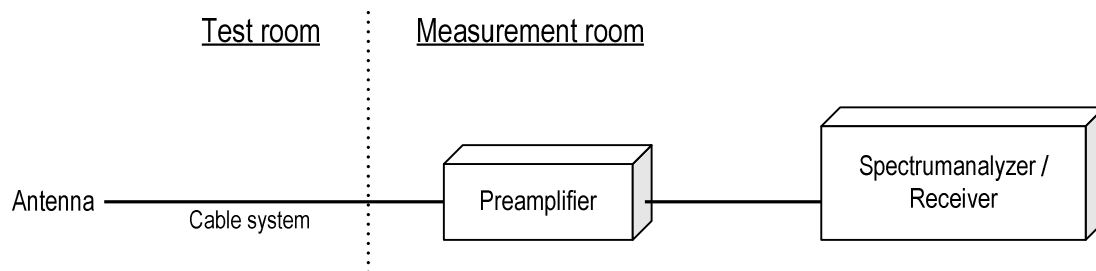

8.2 Calculation method

Result = S.G Reading – Cable loss + Antenna Gain

Margin = Limit – Result (EIRP)

8.3 Limit

-13dBm or less



Zacta

8.4 Test data

Date : Oct. 9, 2013 Test personnel :
 Temperature : 22.0 [°C]
 Humidity : 57.0 [%] Tested by :
 Test place : 3m Semi-anechoic chamber Chiaki Kanno

[Cellular CDMA] (Channel: 1013)

H/V	Frequency [MHz]	S.A Reading [dBm]	S.G Reading [dBm]	Cable loss [dB]	Ant.Gain [dBi]	Result [dBm]	Limit [dBm]	Margin [dB]
H	2475.0	-55.8	-58.0	1.3	7.5	-51.8	-13.0	38.8
V	2474.0	-58.1	-60.7	1.3	7.5	-54.5	-13.0	41.5
H	3298.4	-59.2	-59.0	1.5	7.3	-53.2	-13.0	40.2

(Channel: 384)

H/V	Frequency [MHz]	S.A Reading [dBm]	S.G Reading [dBm]	Cable loss [dB]	Ant.Gain [dBi]	Result [dBm]	Limit [dBm]	Margin [dB]
H	2510.0	-52.6	-53.7	1.3	7.5	-47.5	-13.0	34.5
V	2510.0	-55.0	-55.3	1.3	7.5	-49.1	-13.0	36.1
H	3345.0	-57.9	-56.9	1.5	7.3	-51.1	-13.0	38.1

(Channel: 777)

H/V	Frequency [MHz]	S.A Reading [dBm]	S.G Reading [dBm]	Cable loss [dB]	Ant.Gain [dBi]	Result [dBm]	Limit [dBm]	Margin [dB]
H	2545.0	-51.7	-51.6	1.3	7.4	-45.5	-13.0	32.5
V	2544.0	-53.5	-53.4	1.3	7.4	-47.3	-13.0	34.3
H	3394.0	-58.6	-58.4	1.5	7.5	-52.4	-13.0	39.4

Note: No emission were detected in frequency range 30MHz to 1000MHz at the 3 meters distance.

9. Frequency Stability

9.1 Measurement procedure [FCC 22.355, 2.1055]

The EUT was placed inside of a constant temperature chamber as the temperature in the chamber was varied between -30°C and $+50^{\circ}\text{C}$. The temperature was incremented by 10°C intervals and the unit was allowed to stabilize at each measurement. The frequency drift was measured with the normal Temperature and voltage tolerance and it is presented as the ppm unit.

- Test configuration

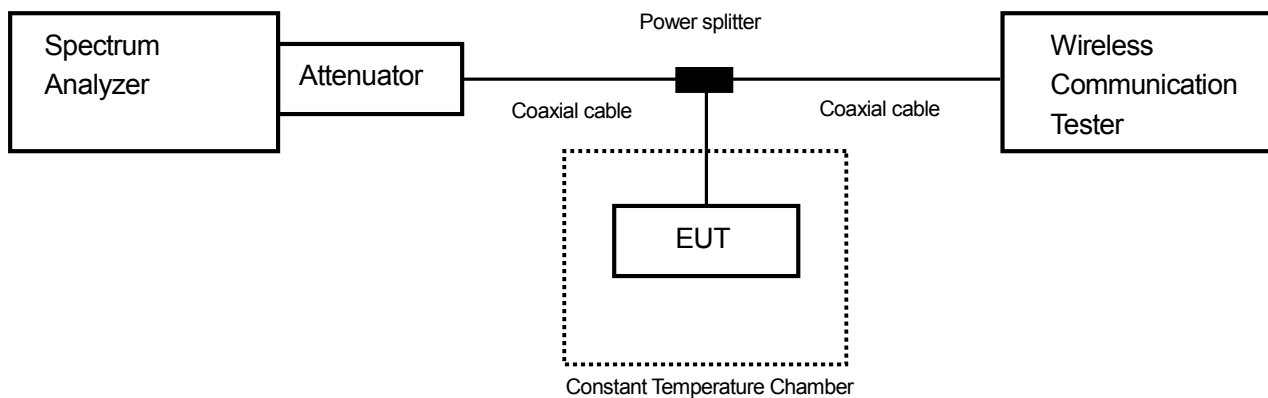

9.2 Limit

$\pm 2.5\text{ppm}$



Zacta

9.3 Measurement result

Date : Oct. 17, 2013
 Temperature : 23.0 [°C]
 Humidity : 62.0 [%]
 Test place : Shielded room

Test personnel

Tested by :

Chiaki Kanno

[Cellular CDMA]

(Channel: 384)

Limit: $\pm 0.00025\% = \pm 2.5\text{ppm}$					
Power Supply [V]	Temperature [°C]	Measurements Frequency [Hz]	Frequency Tolerance [ppm]	Limit [ppm]	Result
3.70	25(Ref.)	836,519,990	0.00000	± 2.5	PASS
	50	836,520,009	0.02268	± 2.5	PASS
	40	836,519,991	0.00122	± 2.5	PASS
	30	836,520,006	0.01944	± 2.5	PASS
	20	836,519,988	-0.00202	± 2.5	PASS
	10	836,519,991	0.00158	± 2.5	PASS
	0	836,519,992	0.00253	± 2.5	PASS
	-10	836,519,988	-0.00201	± 2.5	PASS
	-20	836,520,009	0.02259	± 2.5	PASS
	-30	836,519,990	-0.00026	± 2.5	PASS
3.145	25	836,519,991	0.00105	± 2.5	PASS
4.255	25	836,520,010	0.02347	± 2.5	PASS

Calculation;

$$\text{Frequency Tolerance (ppm)} = \frac{\text{Measurements Frequency (Hz)} - \text{Reference Frequency (Hz)}}{\text{Reference Frequency (Hz)}} \times 1000000$$



Zacta

10. Uncertainty of measurement

Expanded uncertainties stated are calculated with a coverage Factor $k=2$.

Please note that these results are not taken into account when determining compliance or non-compliance with test result.

Test item	Measurement uncertainty
Conducted emission at mains port	$\pm 3.0\text{dB}$
Radiated emission (9kHz – 30MHz)	$\pm 4.4\text{dB}$
Radiated emission (30MHz – 1000MHz)	$\pm 4.5\text{dB}$
Radiated emission (1000MHz – 26GHz)	$\pm 3.9\text{dB}$



Zacta

11. Laboratory description

1. Location:

TÜV SÜD Zacta Ltd. Yonezawa Testing Center
 4149-7 Hachimanpara 5-chome Yonezawa-shi Yamagata 992-1128 Japan
 Phone: +81-238-28-2880 Fax: +81-238-28-2888

2. Facility filing information:

1) NVLAP accreditation: NVLAP Lab. code: 200306-0

2) VLAC accreditation: Lab. code: VLAC-013

Site name	Radiated emission	Conducted emission for mains port	Conducted emission for telecom port	Radiated emission (CMAD)	Expiry Date
3m Semi-anechoic chamber	VLAC-013	-	-	-	Jul. 3, 2015
10m Semi-anechoic chamber				VLAC-013	
Shielded room No.1	-	VLAC-013	-	-	

3) FCC filing:

Site name	Registration Number	Expiry Date
Site 2	91065	Oct.31, 2014
Site 3		
3m Semi-anechoic chamber	540072	Jan. 9, 2016
10m Semi-anechoic chamber		
Shielded room No.1		

4) Industry Canada Oats site filing:

Site name	Sites on file: Oats 3m/10m	Expiry Date
Site 2	4224A-2	Jan. 23, 2015
Site 3	4224A-3	
3m Semi-anechoic chamber	4224A-4	
10m Semi-anechoic chamber	4224A-5	

5) VCCI site filing:

Site name	Radiated emission	Conducted emission for mains port	Conducted emission for telecom port	Expiry Date
Site 2	R-137	C-133	T-1221	Nov. 16, 2014 Nov. 28, 2014* (*:Telecom port)
Site 3	R-138	C-134	T-1222	
3m Semi-anechoic chamber	-	A-0166	-	Jul. 3, 2015
10m Semi-anechoic chamber				
Shielded room No.1				

6) TÜV SÜD PS authorization:

Authorized as an EMC test laboratory

7) TÜV Rheinland authorization:

Authorized as an EMC test laboratory

Appendix A. Test equipment

[Antenna port conducted test]

Equipment	Company	Model No.	Serial No.	Cal. due	Cal. date
Spectrum analyzer	Agilent Technologies	E4440A	US44302655	May 2014	May 14, 2013
Microwave cable	RS	YH_13S5	N/A (S403)	May 2014	May 10, 2013
Microwave cable	SUHNER	SUCOFLEX104/1.5m	322086/4	Jul. 2014	Jul. 30, 2013
Microwave cable	SUHNER	SUCOFLEX104/1.5m	322087/4	Jul. 2014	Jul. 30, 2013
Attenuator	Weinschel	56-10	J4180	Nov. 2013	Nov. 12, 2012
Power splitter	ANRITSU	K240B	020205	Nov. 2013	Nov. 12, 2012
Wideband radio frequency tester	ROHDE&SCHWARZ	CMW500	126079	Aug. 2014	Aug. 7, 2013
Operation type temperature controlled bath	Espec	PL3KP	14016727	Dec. 2013	Dec. 27, 2012

Radiated emission

Equipment	Company	Model No.	Serial No.	Cal. Due	Cal. Date
EMI Receiver	ROHDE&SCHWARZ	ECSI	100451	Oct. 2013	Oct. 26, 2012
Preamplifier	ANRITSU	MH648A	M96057	Jun. 2014	Jun. 12, 2013
Biconical antenna	Schwarzbeck	VHA9103/BBA9106	2155	May 2014	May 1, 2013
Log periodic antenna	Schwarzbeck	UHALP9108A	0560	May 2014	May 1, 2013
Attenuator	TME	CFA-01NPJ-6	N/A (S275)	Jun. 2014	Jun. 6, 2013
Attenuator	TME	CFA-01NPJ-3	N/A (S272)	Jun. 2014	Jun. 6, 2013
Spectrum analyzer	Agilent Technologies	E4447A	MY46180188	Mar. 2014	Mar. 8, 2013
Preamplifier	Agilent Technologies	8449B	3008A1008	Dec. 2013	Dec. 9, 2012
Double ridged guide antenna	EMCO	3115	4328	Jan. 2014	Jan. 21, 2013
Attenuator	AEROFLEX	40A-03	081217-20	Feb. 2014	Feb. 23, 2013
Broad-Band Horn Antenna	Schwarzbeck	BBHA9170	BBHA9170189	May 2015	May 2, 2013
Preamplifier	TSJ	MLA-1840-B03-35	1240332	May 2015	May 2, 2013
Dipole antenna	Schwarzbeck	VHAP	1021	Sep. 2014	Sep. 19, 2013
Dipole antenna	Schwarzbeck	UHAP	993	Sep. 2014	Sep. 19, 2013
Double ridged guide antenna	EMCO	3115	00058532	Sep. 2014	Sep. 6, 2013
Signal generator	Agilent Technologies	8648C	3847M00468	Jun. 2014	Jun. 18, 2013
Signal generator	ROHDE&SCHWARZ	SMR27	839256/034	Jan. 2014	Jan. 30, 2013
Microwave cable	SUHNER	SUCOFLEX104/1.5m	322086/4	Jul. 2014	Jul. 30, 2013
Wideband radio frequency tester	ROHDE&SCHWARZ	CMW500	126079	Aug. 2014	Aug. 7, 2013
Notch filter	Micro-Tronics	BRM50706	003	Jul. 2014	Jul. 12, 2013
Microwave cable	SUHNER	SUCOFLEX104/9m	346316/4	Oct. 2014	Oct. 6, 2013
		SUCOFLEX104/1m	322084/4	Oct. 2014	Oct. 6, 2013
		SUCOFLEX104/1.5m	317226/4	Oct. 2014	Oct. 6, 2013
		SUCOFLEX104/7m	41625/6	Oct. 2014	Oct. 6, 2013
PC	DELL	DIMENSION E521	75465BX	N/A	N/A
Software	TOYO Corporation	EP5/RE-AJ	0611193/V5.3.61	N/A	N/A
3m Semi-anechoic chamber	TOKIN	N/A	N/A (9002-NSA)	May 2014	May 6, 2013
3m Semi-anechoic chamber	TOKIN	N/A	N/A (9002-SVSWR)	May 2014	May 6, 2013