



Zacta

TEST REPORT

Report number : Z101C-15070

Issue date : July 10, 2015

The device, as described herewith, was tested pursuant to applicable test procedure and complies with the requirements of;

FCC Part 27 Subpart C IC RSS-130

The test results are traceable to the international or national standards.

Applicant	: KYOCERA Corporation
Equipment under test (EUT)	: Module
Model number	: J79
FCC ID	: JOYJ79
IC Certification Number	: 574B-J79

Date of test : June 16, 17, 19, 24, 25, July 1, 2015

Test place : TÜV SÜD Zacta Ltd. Yonezawa Testing Center
4149-7 Hachimanpara 5-chome
Yonezawa-shi Yamagata 992-1128 Japan
Phone: +81-238-28-2880 Fax: +81-238-28-2888

Test results : Complied

The results in this report are applicable only to the equipment tested.
This report shall not be re-produced except in full without the written approval of TÜV SÜD Zacta Ltd.
This test report must not be used by the client to claim product certification, approval, or endorsement by NVLAP, NIST, or any agency of the federal government.

Tested by : Taiki Watanabe
Taiki Watanabe

Tested by : Hikaru Shibata
Hikaru Shibata

Authorized by : Hiroaki Suzuki
Hiroaki Suzuki
Manager of EMC Technical Department



Table of contents

	Page
1. Summary of Test	4
1.1 Purpose of test	4
1.2 Standards	4
1.3 List of applied test to the EUT	4
1.4 Modification to the EUT by laboratory	4
2. Equipment Under Test	5
2.1 General Description of equipment	5
2.2 EUT information	5
2.3 Variation of the family model(s)	6
2.4 Description of Test mode	6
3. Configuration of equipment	7
3.1 Equipment(s) used	7
3.2 Cable(s) used	7
3.3 System configuration	7
4. Conducted Output Power	8
4.1 Measurement procedure	8
4.2 Measurement result	8
5. Effective Radiated Power	10
5.1 Measurement procedure	10
5.2 Calculation method	10
5.3 Limit	10
5.4 Test data	11
6. Peak to Average Ratio	12
6.1 Measurement procedure	12
6.2 Limit	12
6.3 Measurement result	12
6.4 Trace data	13
7. Occupied Bandwidth	15
7.1 Measurement procedure	15
7.2 Limit	15
7.3 Measurement result	16
7.4 Trace data	17
8. Band Edge Spurious and Harmonic at Antenna Terminals	21
8.1 Measurement procedure	21
8.2 Limit	21
8.3 Measurement result	21
8.4 Trace data	22
9. Radiated Emissions and Harmonic Emissions	36
9.1 Measurement procedure	36
9.2 Calculation method	36
9.3 Limit	36
9.4 Test data	37
10. Frequency Stability	40



Zacta

10.1 Measurement procedure	40
10.2 Limit	40
10.3 Measurement result	41
11. Uncertainty of measurement	42
12. Laboratory description	43
Appendix A. Test equipment	44



Zacta

1. Summary of Test

1.1 Purpose of test

It is the original test in order to verify conformance to FCC Part 27 Subpart C, IC RSS-130.

1.2 Standards

CFR47 FCC Part 27 Subpart C
IC RSS-130

1.2.1 Test Methods

ANSI/TIA/EIA-603-C-2004

1.2.2 Deviation from standards

None

1.3 List of applied test to the EUT

FCC Section	IC Section	Test items	Condition	Result
2.1046	N/A	Conducted Output Power	Conducted	PASS
27.50(b)(10)	RSS-130 4.4	Effective Radiated Power	Radiated	PASS
27.50(d)(5)	N/A	Peak to Average Ratio	Conducted	PASS
2.1049	RSS-130 4.3	Occupied Bandwidth	Conducted	PASS
27.53(g) 2.1051	RSS-130 4.6	Band Edge Spurious and Harmonic at Antenna Terminal	Conducted	PASS
27.53(g) 2.1053	RSS-130 4.6	Radiated emissions and Harmonic Emissions	Radiated	PASS
27.54 2.1055	RSS-130 4.3	Frequency Stability	Conducted	PASS

1.3.1 Test set up

Table-Top

1.4 Modification to the EUT by laboratory

None



Zacta

2. Equipment Under Test

2.1 General Description of equipment

EUT is the Module.

2.2 EUT information

Applicant	:	KYOCERA Corporation Yokohama Office 2-1-1 Kagahara, Tsuzuki-ku Yokohama-shi, Kanagawa, Japan Phone: +81-45-943-6253 Fax: +81-45-943-6314
Equipment under test	:	Module
Trade name	:	Kyocera
Model number	:	J79
Serial number	:	N/A
EUT condition	:	Pre-Production
Power ratings	:	DC 3.9V
Size	:	(W) 40.0 × (D) 40.0 × (H) 4.3 mm
Environment	:	Indoor and Outdoor use
Terminal limitation	:	-20°C to 60°C
RF Specification Frequency of Operation	:	Up Link LTE Band X III: 777-787MHz Down Link LTE Band X III: 746-756MHz
Modulation type	:	QPSK, 16QAM
Emission designator	:	BW 5M QPSK: 4M51G7W, 16QAM: 4M49 D7W BW 10M QPSK: 9M02G7W, 16QAM: 9M02 D7W
Output power	:	QPSK: 0.072W ERP (18.6dBm) 16QAM: 0.071W ERP (18.5dBm)
Antenna type	:	External antenna
Antenna gain	:	3.7dBi

2.3 Variation of the family model(s)

Not applicable

2.4 Description of Test mode

The EUT had been tested under operating condition.
There are three channels have been tested as following:

Band	Modulation	Bandwidth	Channel	Frequency [MHz]	
LTE Band X III	QPSK	5MHz	23205	779.5	
			23230	782.0	
	23255		784.5		
	16QAM	10MHz	5MHz	23230	782.0
				10MHz	5MHz
		5MHz	23230		
23255			784.5		
10MHz	5MHz	23230	782.0		

The field strength of spurious emissions was measured at each position of all three axis X, Y and Z to compare the level, and the maximum noise.

The worst emission was found in Y axis and the worst case recorded.

3. Configuration of equipment

3.1 Equipment(s) used

No.	Equipment	Company	Model No.	Serial No.	FCC ID / DoC	Comment
1	Module	KYOCERA	J79	N/A	JOYJ79	EUT
2	JOINT BOARD	KYOCERA	N/A	N/A	N/A	-
3	SHARK Antenna	YOKOWO	N/A	N/A	N/A	-
4	Whip Antenna	EAD	PTR7210	N/A	N/A	-
5	GPS Antenna	PASTERNAK	PE51066	N/A	N/A	-

3.2 Cable(s) used

No.	Cable	Length[m]	Shield	Connector	Comment
a	RF cable (MAIN)	0.3	YES	Metal	-
b	RF cable (SUB)	0.3	YES	Metal	-
c	GPS Antenna cable	5.0	YES	Metal	-
d	DC cable	1.3	NO	Plastic	-
e	RF cable	0.9	YES	Metal	-

3.3 System configuration

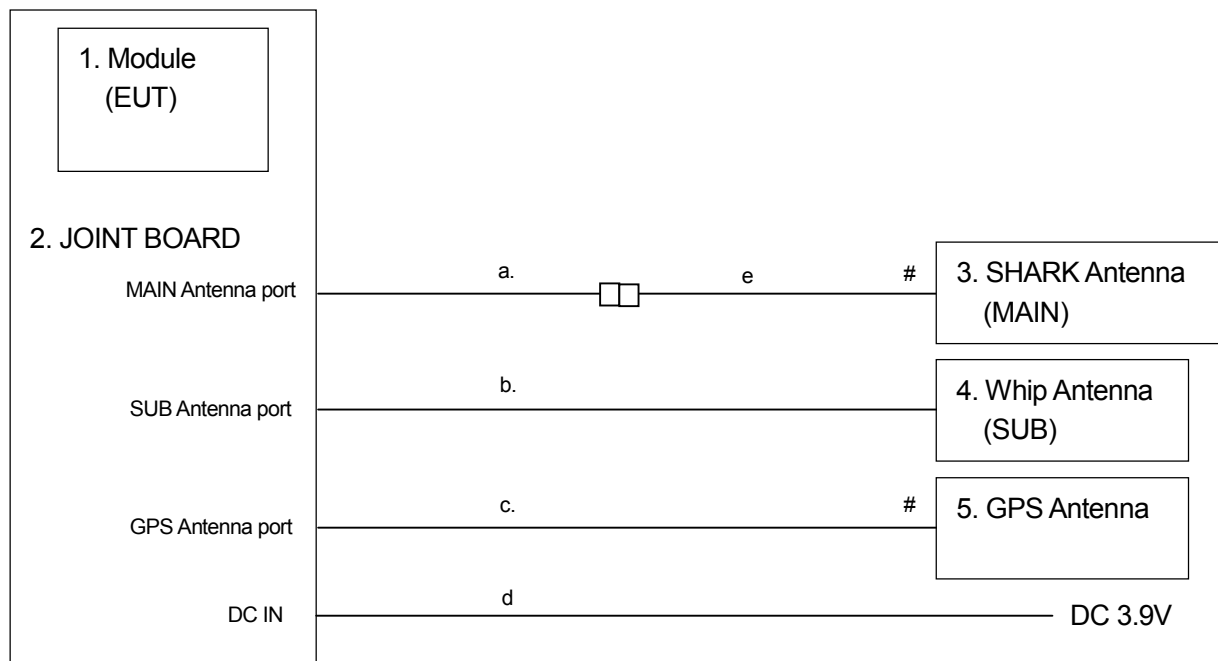

: Un-detachable cable

□ : Connector

Note1: Numbers assigned to equipment or cables on this diagram correspond to the list in "3.1 Equipment(s) used" and "3.2 Cable(s) used".

4. Conducted Output Power

4.1 Measurement procedure [FCC 2.1046]

The conducted output power was measured with a wireless communication tester connected to the antenna terminal. The wireless communication tester parameters were set to produce the maximum power from the EUT.

- Test configuration

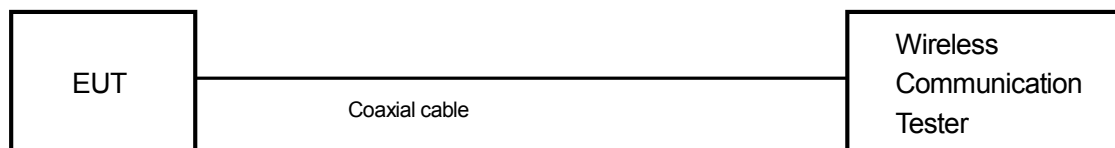

4.2 Measurement result

Date : June 16, 2015
 Temperature : 24.0 [°C]
 Humidity : 45.0 [%]
 Test place : Shielded room No.4

Test engineer :

Hikaru Shibata

Band	BW [MHz]	Mode	RB Allocation	RB offset	Target MPR	Avg Power[dBm]		
						23205	23230	23255
						779.5 MHz	782.0 MHz	784.5 MHz
LTE Band 13	5	QPSK	1	0	0	22.57	22.44	22.79
			1	12	0	22.38	22.61	22.77
			1	24	0	22.60	22.69	22.78
			12	0	1	21.62	21.61	21.71
			12	7	1	21.45	21.63	21.85
			12	13	1	21.53	21.63	21.74
			25	0	1	21.53	21.68	21.73
		16QAM	1	0	1	21.52	21.13	21.69
			1	12	1	21.42	21.36	21.72
			1	24	1	21.63	21.41	21.71
			12	0	2	20.61	20.62	20.77
			12	7	2	20.54	20.75	20.81
			12	13	2	20.61	20.75	20.76
			25	0	2	20.59	20.72	20.80



Zacta

Band	BW [MHz]	Mode	RB Allocation	RB offset	Target MPR	Avg Power[dBm]
						23230
						782.0 MHz
LTE Band 13	10	QPSK	1	0	0	22.51
			1	25	0	22.65
			1	49	0	22.71
			25	0	1	21.50
			25	12	1	21.60
			25	25	1	21.72
			50	0	1	21.53
		16QAM	1	0	1	21.37
			1	25	1	20.60
			1	49	1	21.62
			25	0	2	20.53
			25	12	2	20.68
			25	25	2	20.71
			50	0	2	20.55

5. Effective Radiated Power

5.1 Measurement procedure

[FCC 27.50(b)(10), IC RSS-130 4.4]

<Step 1>

The EUT and support equipment are placed on a 1 meter x 1.5 meter surface, 0.8 meter height FRP table. Radiated emission measurements are performed at 3 meter distance with the broadband antenna (double ridged guide antenna). The antenna is positioned both the horizontal and vertical planes of polarization and height is varied 1 to 4 meters and stopped at height producing the maximum emission. The bandwidth of the spectrum analyzer is set to 1MHz. The turntable is rotated by 360 degrees and stopped at azimuth of producing the maximum emission.

<Step 2>

The substitution antenna is replaced by the transmitter antenna (EUT). The frequency of the signal generator is adjusted to the measurement frequency. Level of the signal generator is adjusted to the level that is obtained from step 1, and record the emission level of signal generator.

Spectrum analyzer setting

- Detector: RMS Average (RBW: 430kHz, VBW: 1.5MHz)

- Test configuration

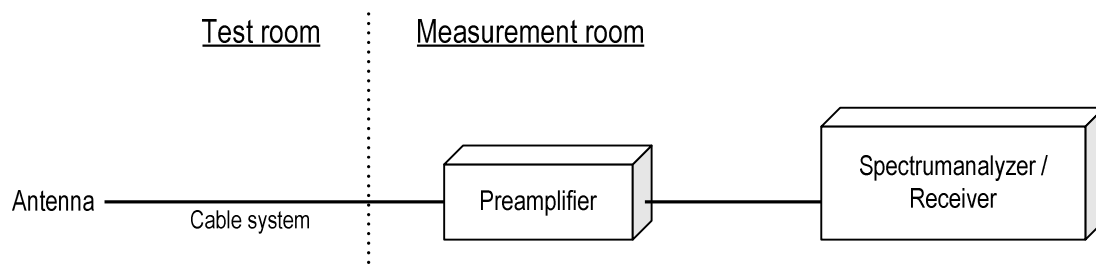

5.2 Calculation method

Result (ERP) = S.G Reading – Cable loss + Antenna Gain

Margin = Limit – Result (ERP)

Example:

Limit @ 782.0MHz : 34.7dBm

S.G Reading = 29.8dBm Cable loss = 0.7dB Ant. Gain = -10.5dB

Result = 29.8 - 0.7 + (-10.5) = 18.6dBm

Margin = 34.7 – 18.6 = 16.1dB

5.3 Limit

3 W (34.7dBm)



Zacta

5.4 Test data

Date : June 19, 2015
 Temperature : 24.7 [°C]
 Humidity : 48.4 [%]
 Test place : 3m Semi-anechoic chamber
 Test engineer : Taiki Watanabe

Date : July 1, 2015
 Temperature : 23.7 [°C]
 Humidity : 58.2 [%]
 Test place : 3m Semi-anechoic chamber
 Test engineer : Hikaru Shibata

[LTE Band X III] QPSK, BW 5MHz

H/V	Frequency [MHz]	S.A Reading [dBm]	S.G Reading [dBm]	Cable loss [dB]	Ant.Gain [dBd]	Result [dBm]	Limit [dBm]	Margin [dB]
H	779.5	-13.6	28.2	0.7	-10.5	17.0	34.7	17.7
H	782.0	-12.0	29.8	0.7	-10.5	18.6	34.7	16.1
H	784.5	-12.5	29.4	0.7	-10.5	18.2	34.7	16.5

16QAM, BW 5MHz

H/V	Frequency [MHz]	S.A Reading [dBm]	S.G Reading [dBm]	Cable loss [dB]	Ant.Gain [dBd]	Result [dBm]	Limit [dBm]	Margin [dB]
H	779.5	-12.3	29.5	0.7	-10.5	18.3	34.7	16.4
H	782.0	-14.8	27.0	0.7	-10.5	15.8	34.7	18.9
H	784.5	-12.2	29.7	0.7	-10.5	18.5	34.7	16.2

QPSK, BW 10MHz

H/V	Frequency [MHz]	S.A Reading [dBm]	S.G Reading [dBm]	Cable loss [dB]	Ant.Gain [dBd]	Result [dBm]	Limit [dBm]	Margin [dB]
H	782.0	-12.3	29.5	0.7	-10.5	18.3	34.7	16.4

16QAM, BW 10MHz

H/V	Frequency [MHz]	S.A Reading [dBm]	S.G Reading [dBm]	Cable loss [dB]	Ant.Gain [dBd]	Result [dBm]	Limit [dBm]	Margin [dB]
H	782.0	-13.4	28.4	0.7	-10.5	17.2	34.7	17.5

6. Peak to Average Ratio

6.1 Measurement procedure [FCC 27.50(d)(5)]

The peak to average ratio was measured with a spectrum analyzer connected to the antenna terminal.

The spectrum analyzer is set to;
- Power Stat CCDF mode

- Test configuration

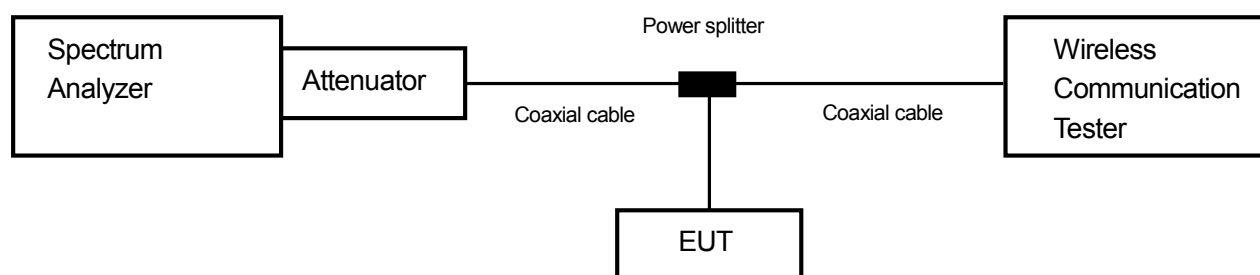

6.2 Limit

13.0dB or less

6.3 Measurement result

Date : June 17, 2015
 Temperature : 25.7 [°C]
 Humidity : 54.5 [%]
 Test place : Shielded room No.4

Test engineer : Hikaru Shibata

Band	Channel	Frequency [MHz]	Modulation	BW [MHz]	RB	Peak to Average Power Ratio [dB]	Limit [dB]
LTE Band X III	23239	782.0	QPSK	5	25-0	5.88	13.0
				10	50-0	4.62	13.0
			16QAM	5	25-0	6.79	13.0
				10	50-0	6.32	13.0



Zacta

6.4 Trace data
[LTE Band X III]
Channel: 23230
QPSK, BW 5MHz, RB25-0

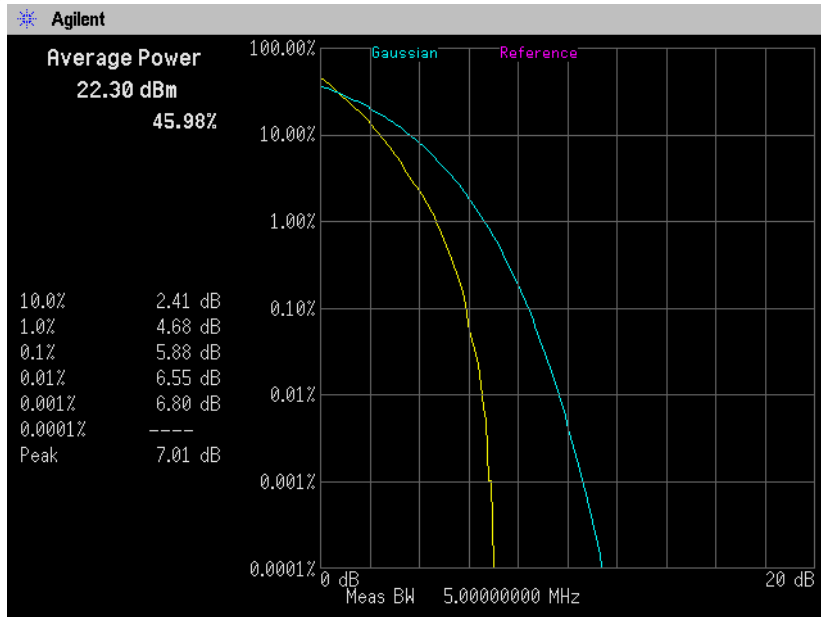

QPSK, BW 10MHz, RB50-0

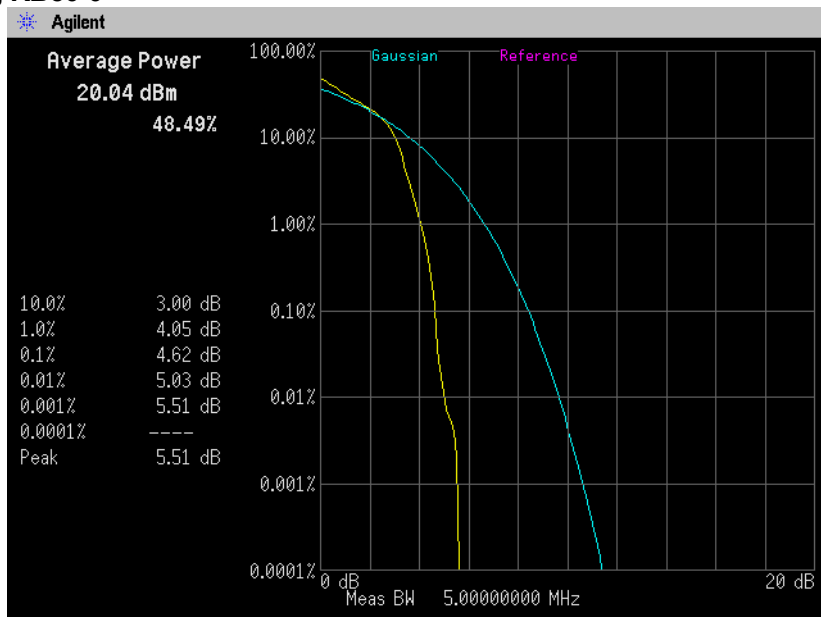



Zacta

16QAM, BW 5MHz, RB25-0

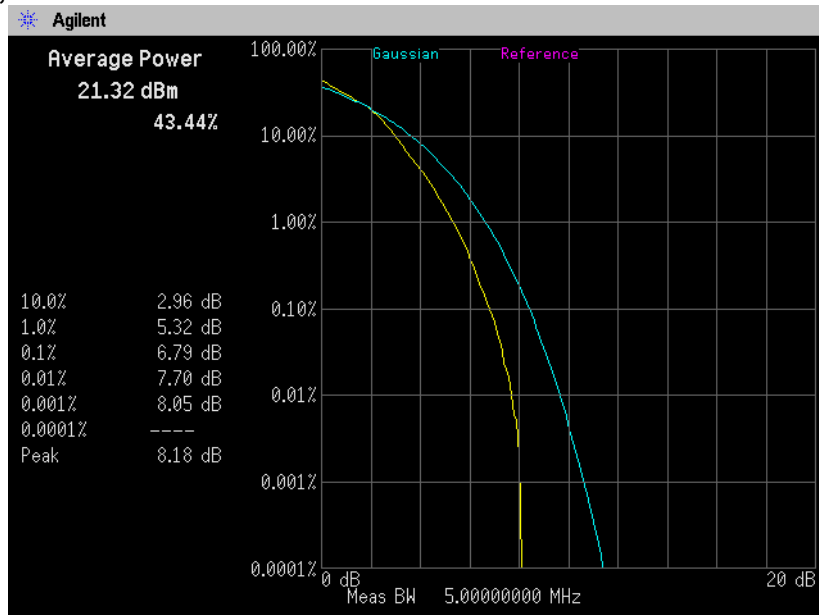

16QAM, BW 10MHz, RB50-0

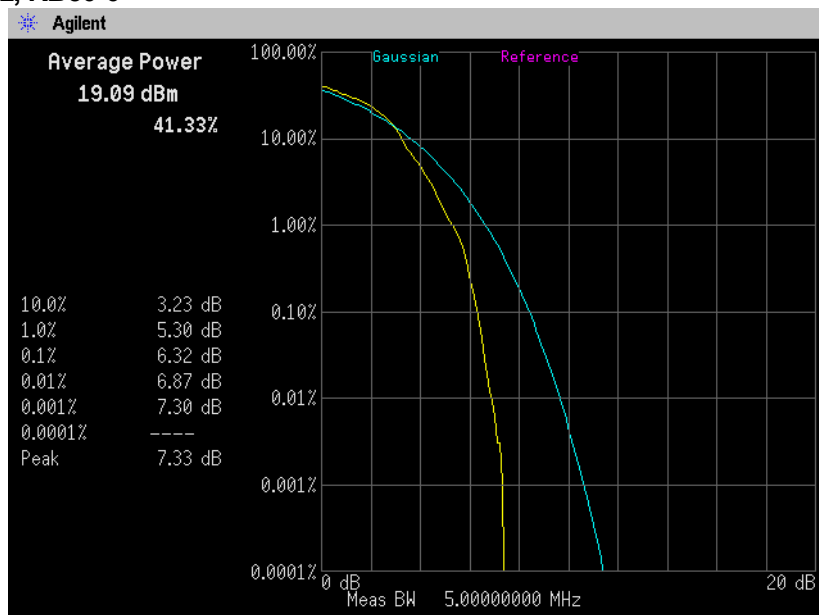

7. Occupied Bandwidth

7.1 Measurement procedure [FCC 2.1049, IC RSS-130 4.3]

The Occupied bandwidth was measured with a spectrum analyzer connected to the antenna terminal.

The spectrum analyzer is set to;

- RBW=100kHz, VBW=300kHz, Span=10MHz, Sweep=auto, Detector=Peak, Trace mode=Max hold
- RBW=200kHz, VBW=620kHz, Span=20MHz, Sweep=auto, Detector=Peak, Trace mode=Max hold

- Test configuration

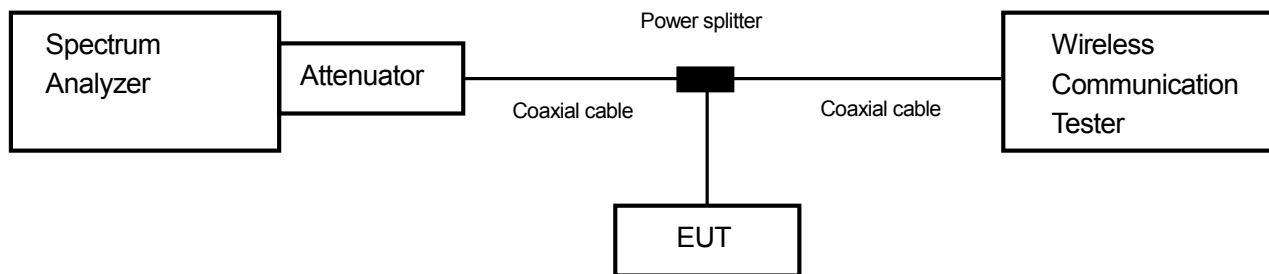

7.2 Limit

None

7.3 Measurement result

Date : June 17, 2015

Temperature : 25.7 [°C]

Humidity : 54.5 [%]

Test place : Shielded room No.4

Test engineer :

Hikaru Shibata

BW	Mode	UL RB Allocation	UL RB Start	Frequency [MHz]	26dB Bandwidth [MHz]	99% OBW [MHz]
5MHz	QPSK	1	0	782.0	0.710	0.5007
		1	24		0.722	0.5002
		12	7		3.426	2.3472
		25	0		5.077	4.5118
5MHz	16QAM	1	0	782.0	0.688	0.4748
		1	24		0.687	0.4845
		12	7		3.377	2.3167
		25	0		5.052	4.4891
10MHz	QPSK	1	0	782.0	1.013	0.7307
		1	49		0.986	0.7049
		25	12		6.713	4.7426
		50	0		10.067	9.0199
10MHz	16QAM	1	0	782.0	0.996	0.7245
		1	49		1.015	0.7278
		25	12		6.884	4.7914
		50	0		9.983	9.0182



Zacta

7.4 Trace data
[LTE Band X III]
Channel: 23095
QPSK, BW 5MHz, RB1-0

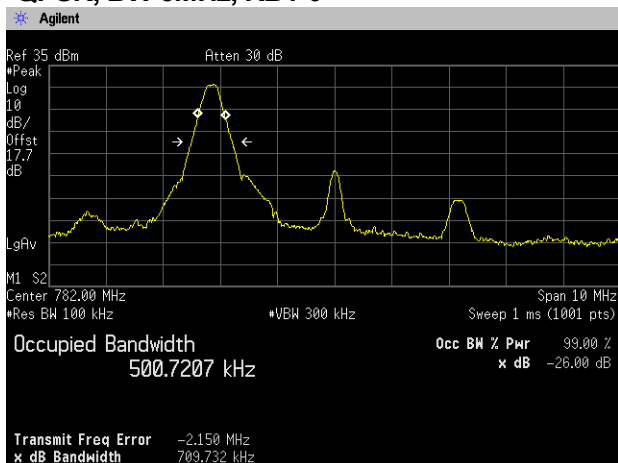

RB1-24

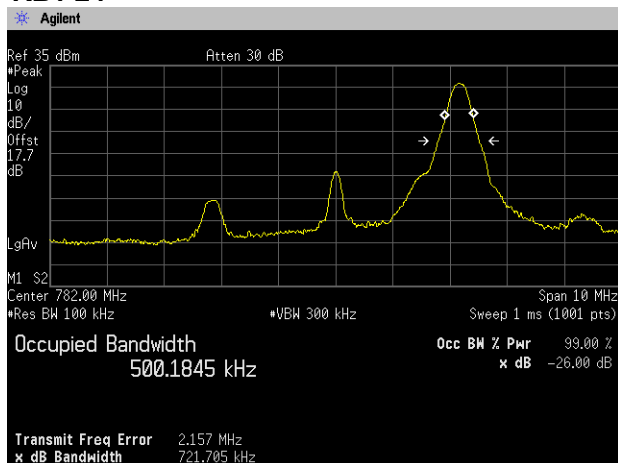

RB12-7

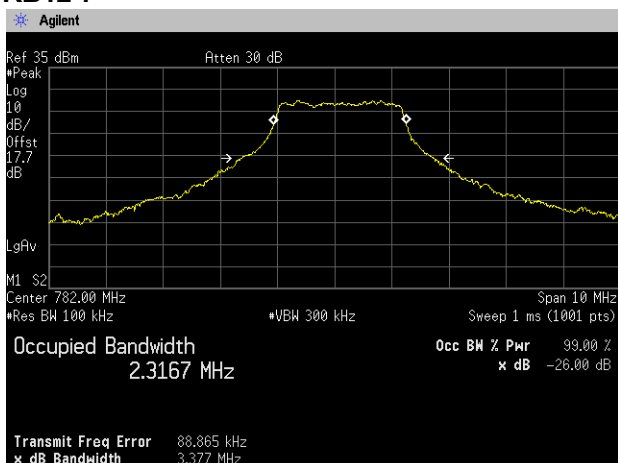

RB25-0

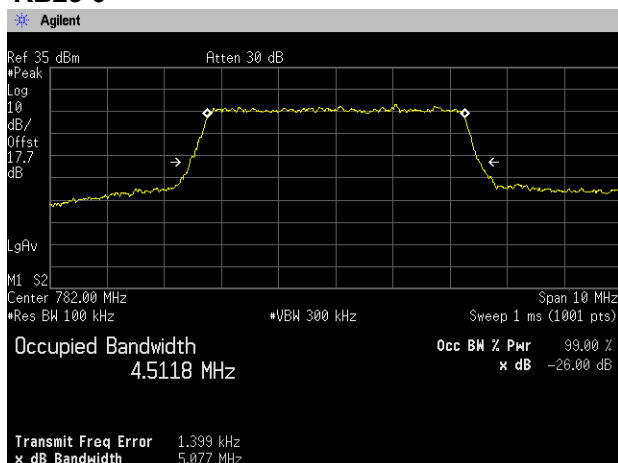



Zacta

16QAM, BW 5MHz, RB1-0

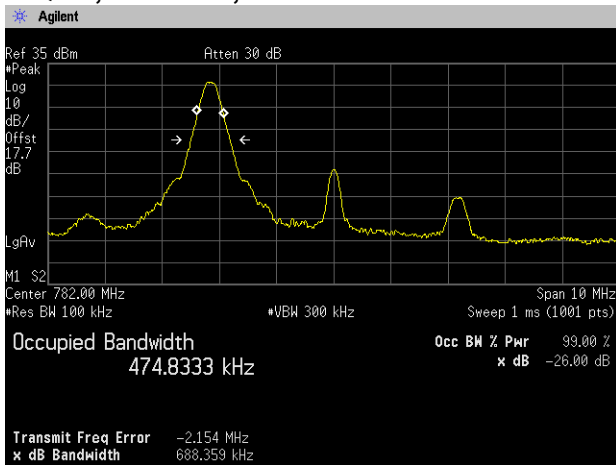

RB1-24

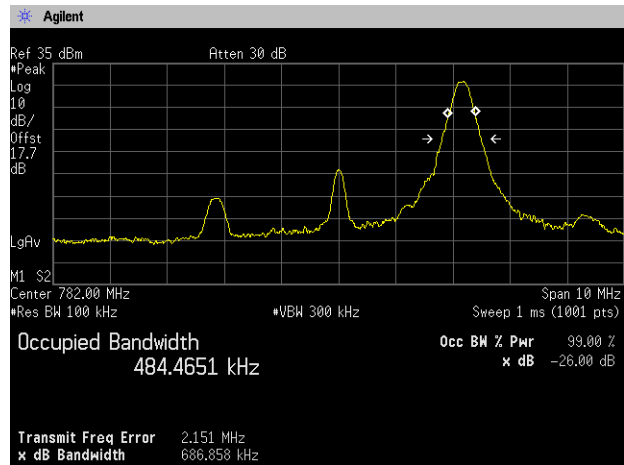

RB12-7

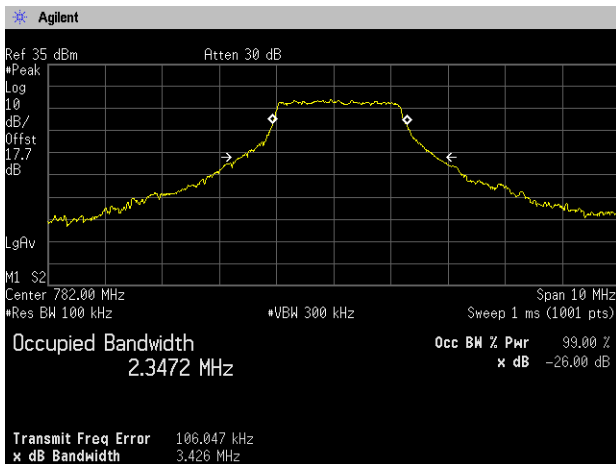

RB25-0

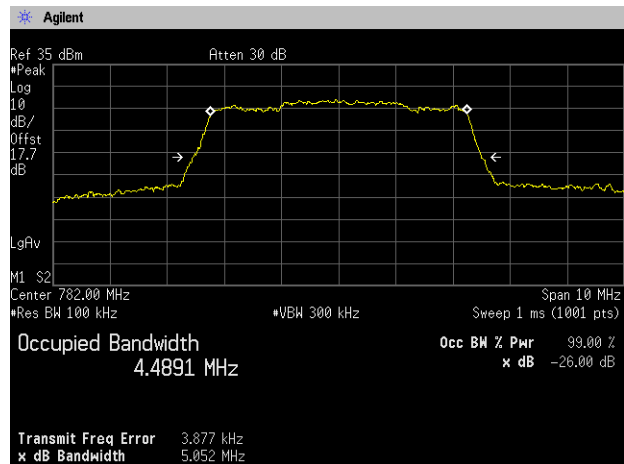



Zacta

QPSK, BW 10MHz, RB1-0

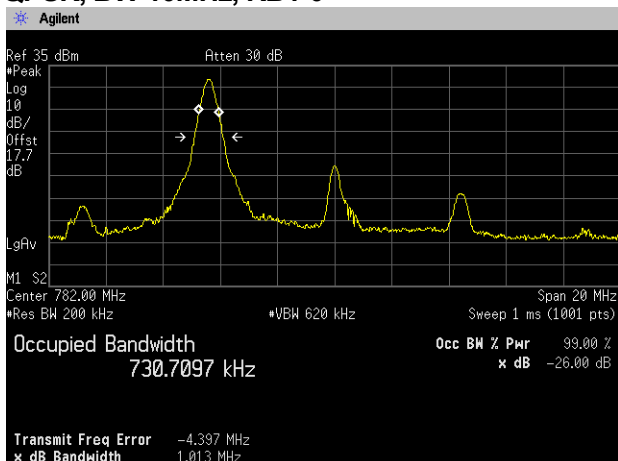

RB1-49

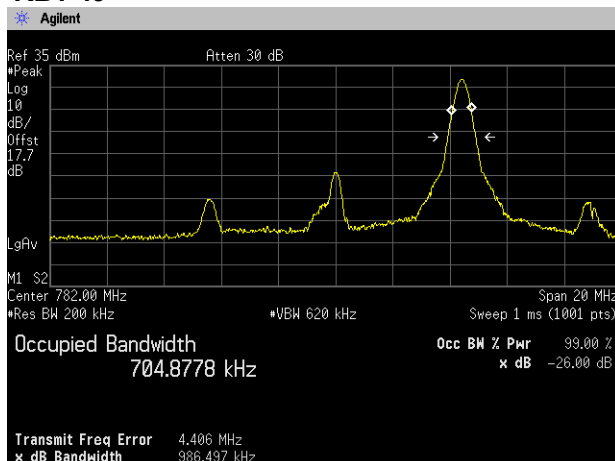

RB25-12

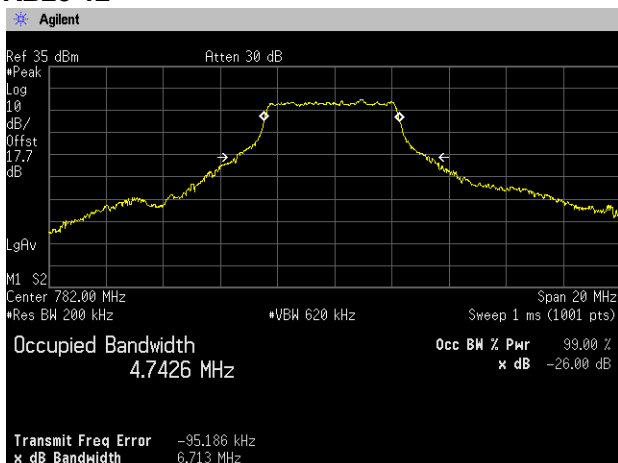

RB50-0

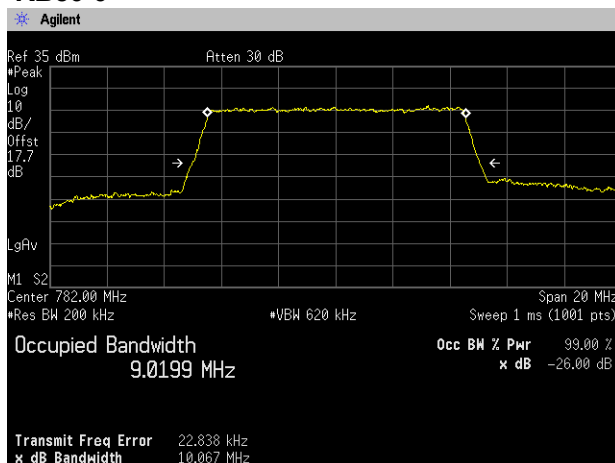



Zacta

16QAM, BW 10MHz, RB1-0

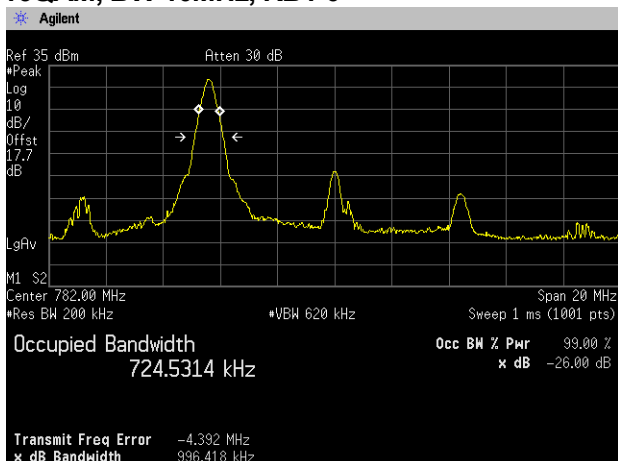

RB1-49

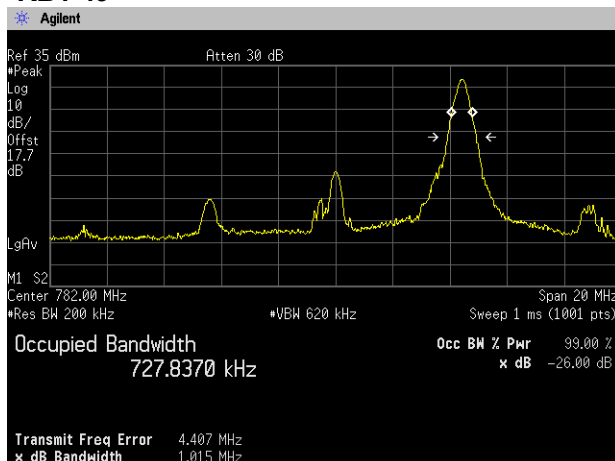

RB25-12

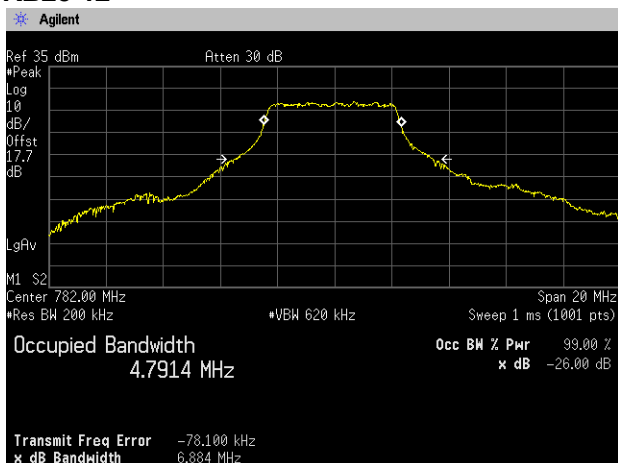

RB50-0

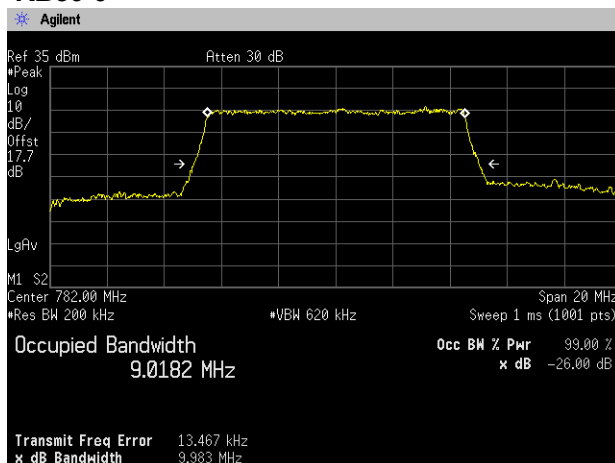

8. Band Edge Spurious and Harmonic at Antenna Terminals

8.1 Measurement procedure

[FCC 27.53(g), 2.1051, IC RSS-130 4.6]

The band edge spurious and harmonic was measured with a spectrum analyzer connected to the antenna terminal.

The spectrum analyzer is set to;

<Band Edge>

- RBW=75kHz, VBW=220kHz, Span=10MHz, Sweep=auto, Detector=RMS, Trace mode=Max hold
- RBW=150kHz, VBW=430kHz, Span=20MHz, Sweep=auto, Detector=RMS, Trace mode=Max hold

<Spurious Emissions>

- RBW=1MHz, VBW=3MHz, Span=Arbitrary setting, Sweep=auto, Detector=Peak, Trace mode=Max hold

- Test configuration

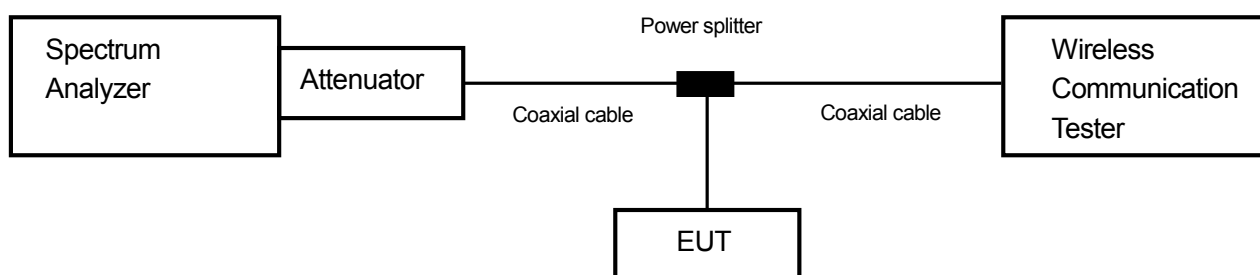

8.2 Limit

-13dBm or less

8.3 Measurement result

Date : June 17, 2015

Temperature : 25.7 [°C]

Humidity : 54.5 [%]

Test place : Shielded room No.4

Test engineer :

Hikaru Shibata

Band	Modulation	Bandwidth	Results	
LTE Band X III	QPSK	5MHz	See the trace data	PASS
		10MHz	See the trace data	PASS
	16QAM	5MHz	See the trace data	PASS
		10MHz	See the trace data	PASS



Zacta

8.4 Trace data
[LTE Band X III]
(Band Edge)
QPSK, BW 5MHz, RB1-0
Channel: Low

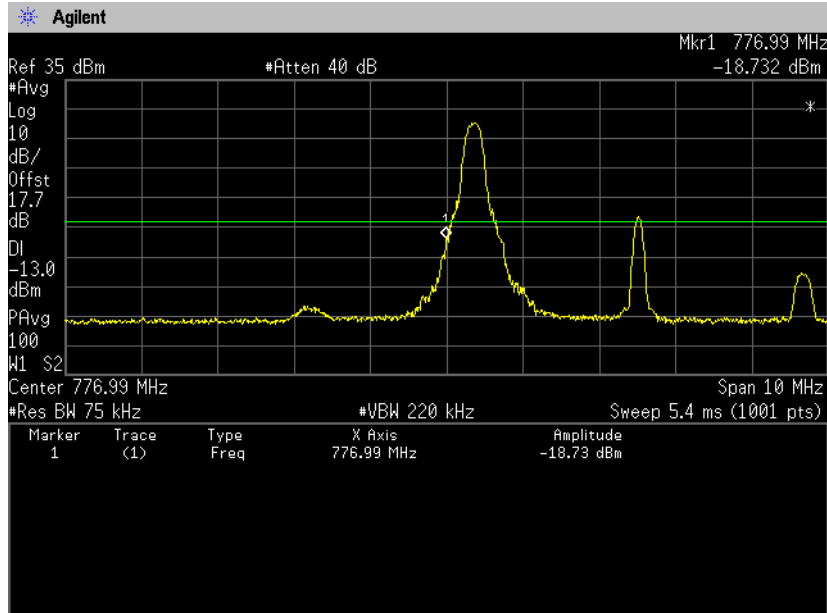

QPSK, BW 5MHz, RB1-24
Channel: High

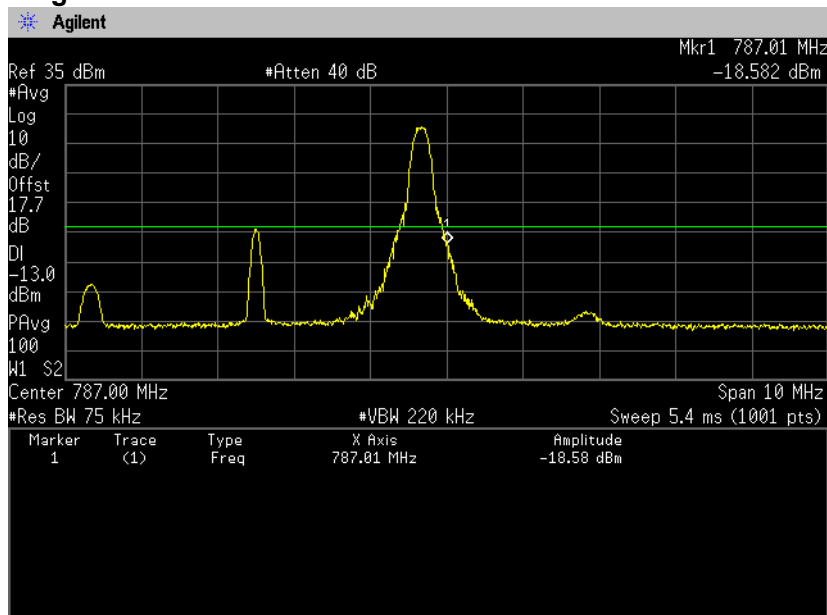



Zacta

QPSK, BW 5MHz, RB25-0
Channel: Low

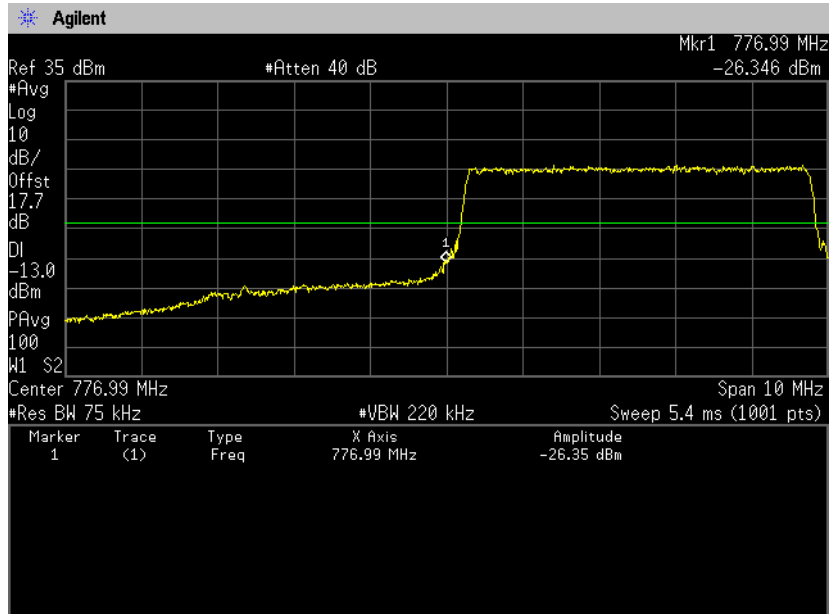

QPSK, BW 5MHz, RB25-0
Channel: High

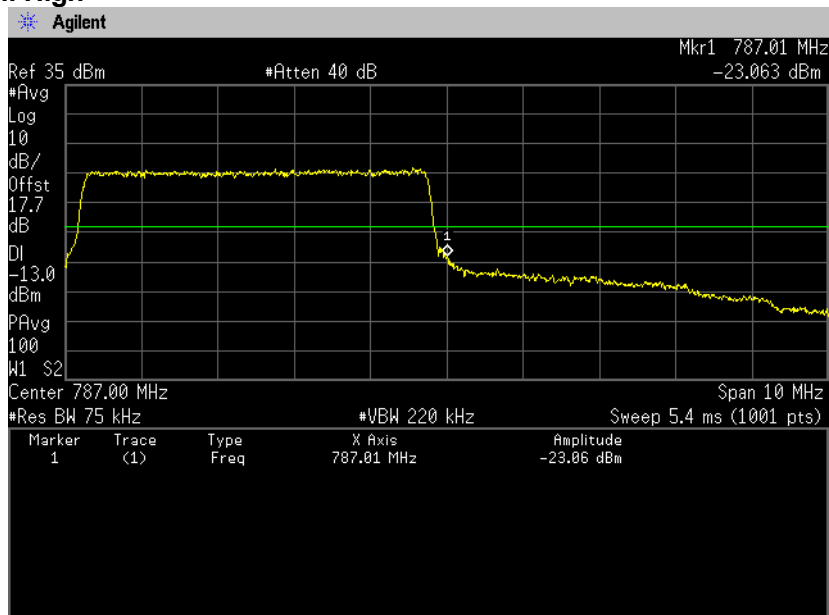



Zacta

16QAM, BW 5MHz, RB1-0
Channel: Low

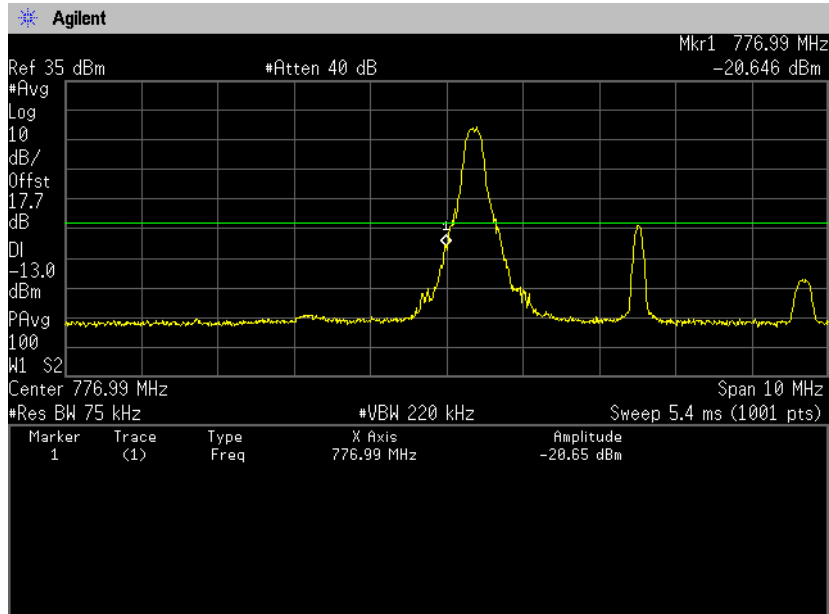

16QAM, BW 5MHz, RB1-24
Channel: High

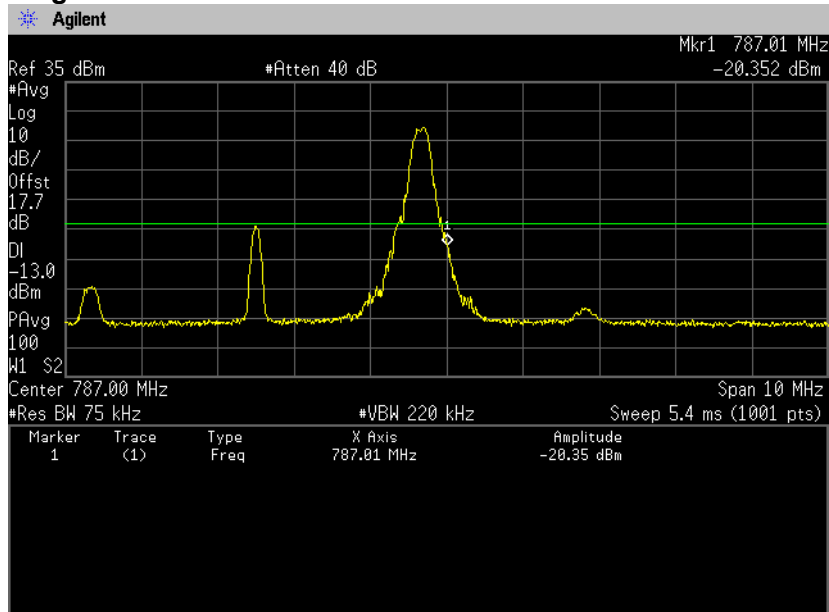



Zacta

16QAM, BW 5MHz, RB25-0 Channel: Low

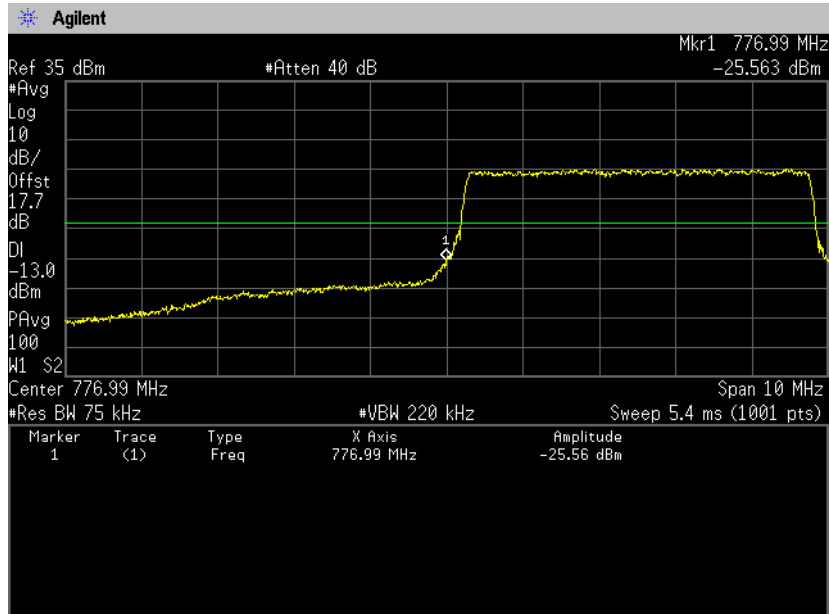

16QAM, BW 5MHz, RB25-0 Channel: High

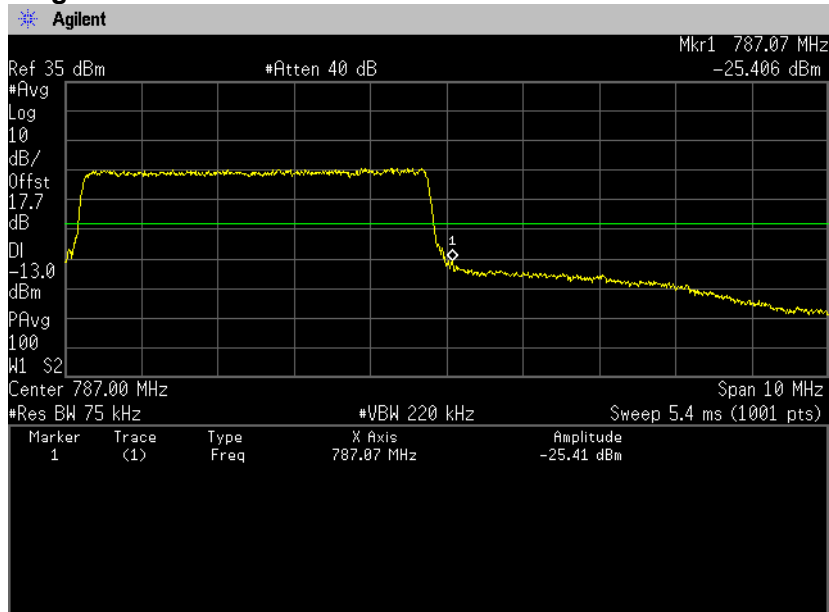



Zacta

QPSK, BW 10MHz, RB1-0 Channel: Low

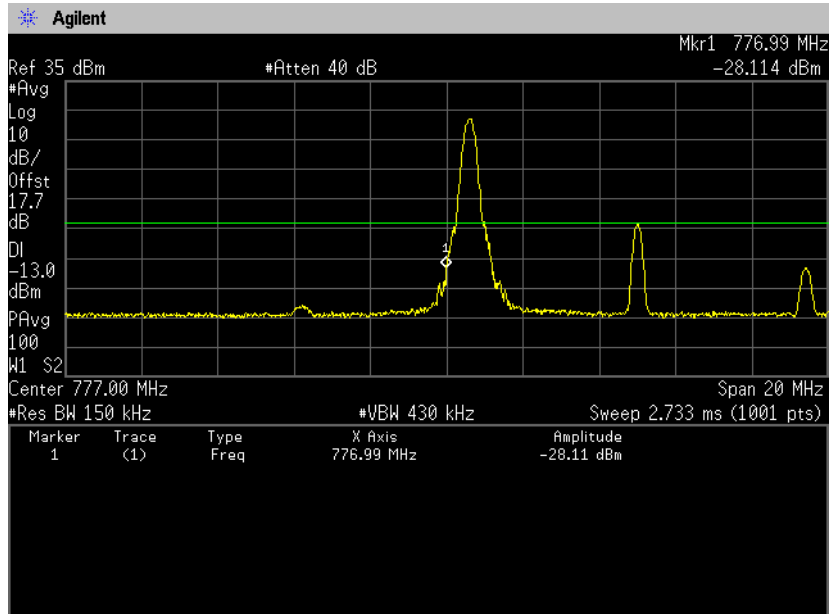

QPSK, BW 10MHz, RB1-49 Channel: High

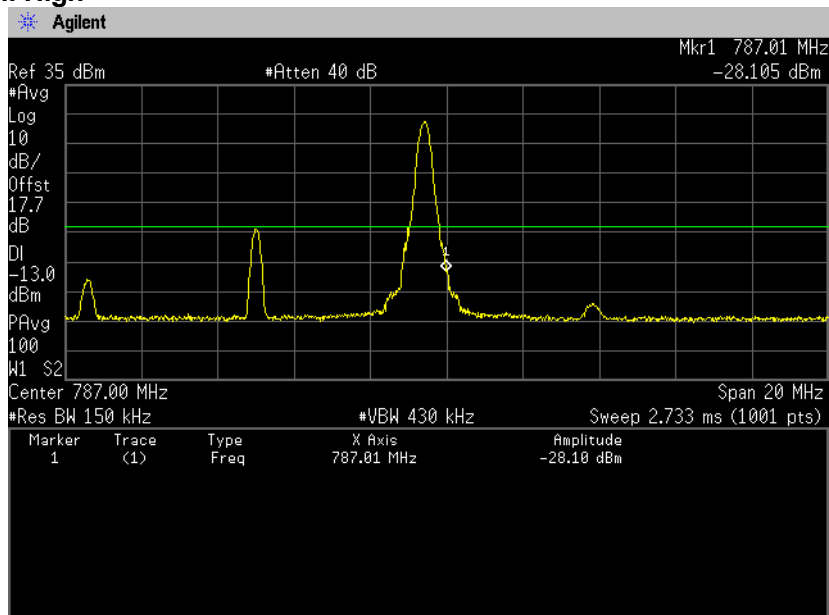



Zacta

QPSK, BW 10MHz, RB50-0 Channel: Low

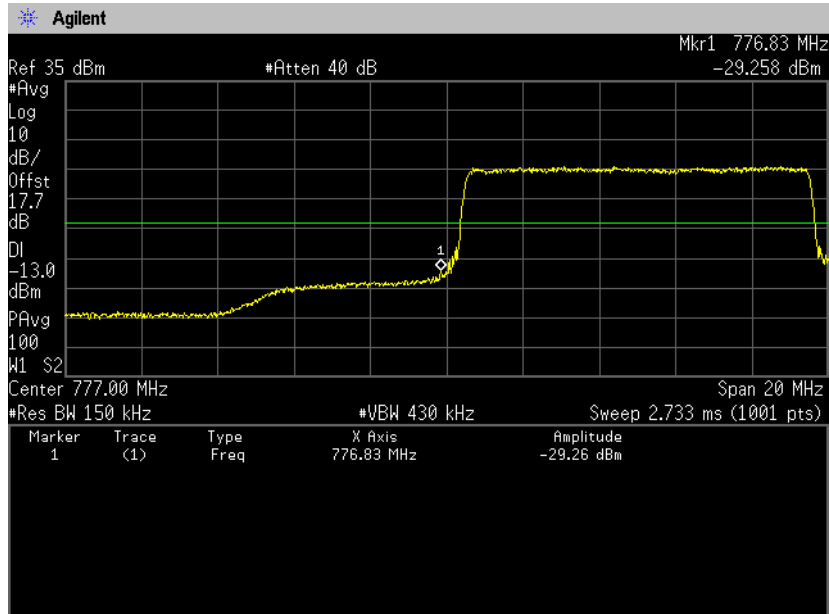

QPSK, BW 10MHz, RB50-0 Channel: High

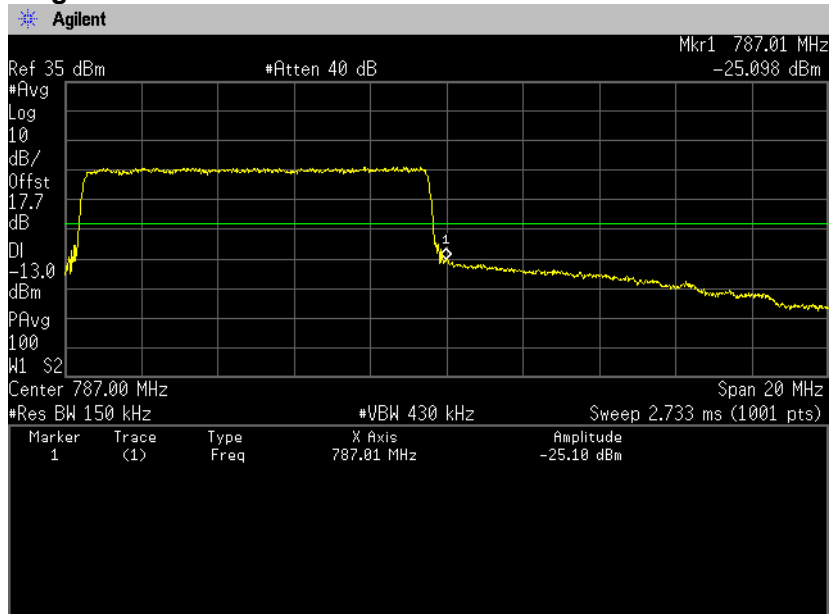



Zacta

16QAM, BW 10MHz, RB1-0
Channel: Low

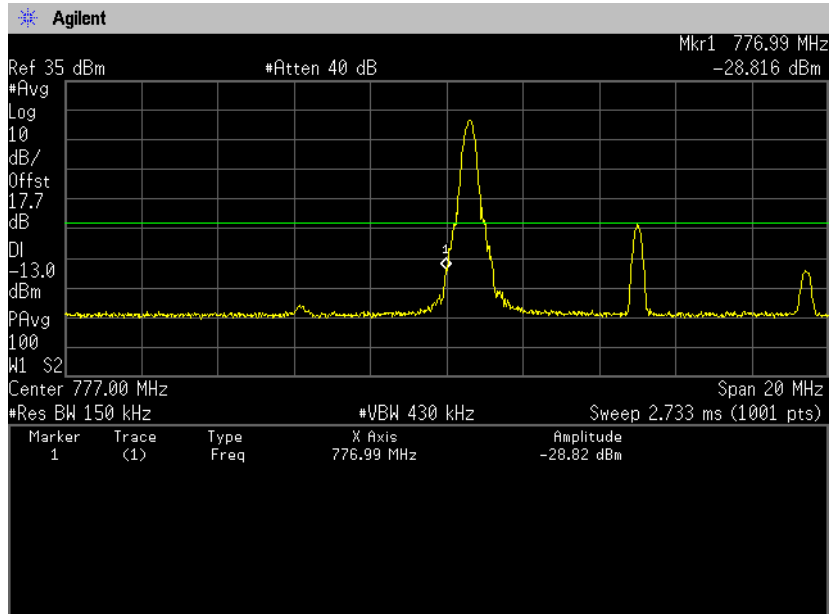

16QAM, BW 10MHz, RB1-49
Channel: High

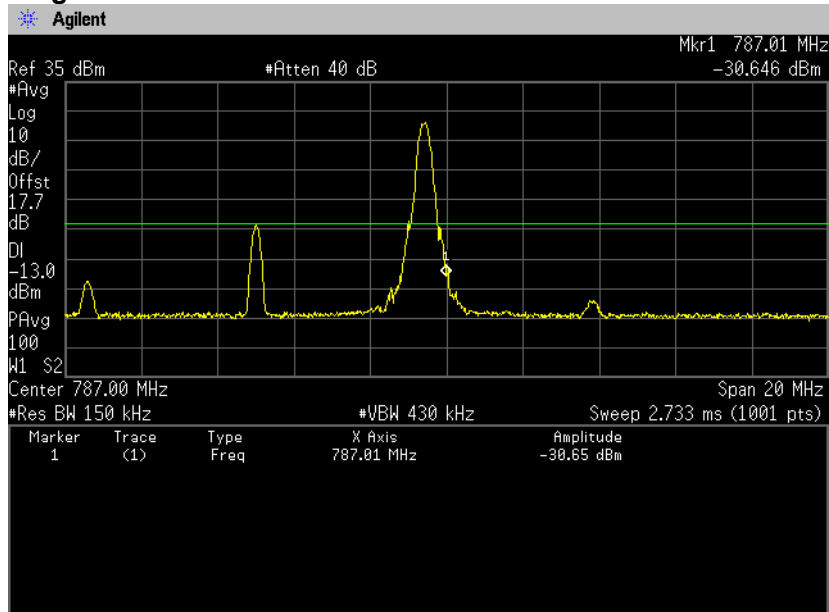



Zacta

16QAM, BW 10MHz, RB50-0 Channel: Low

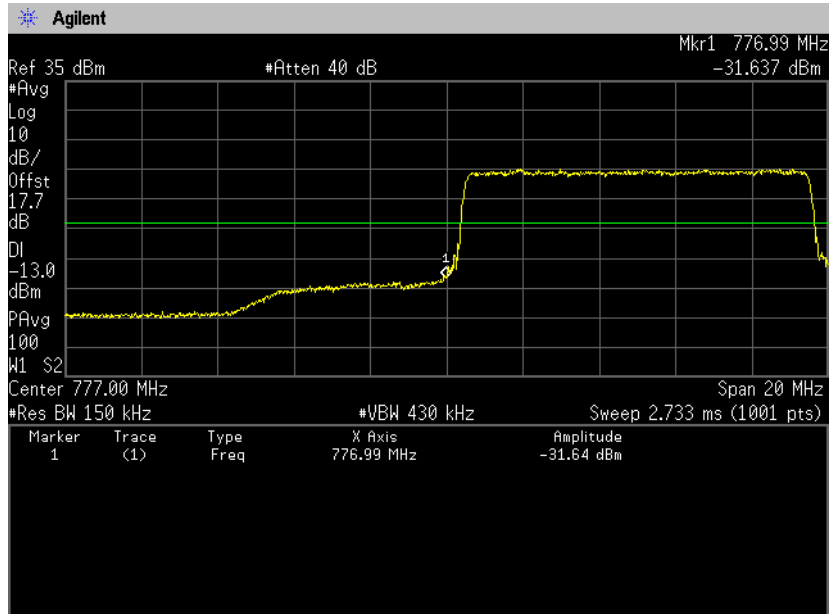

16QAM, BW 10MHz, RB50-0 Channel: High

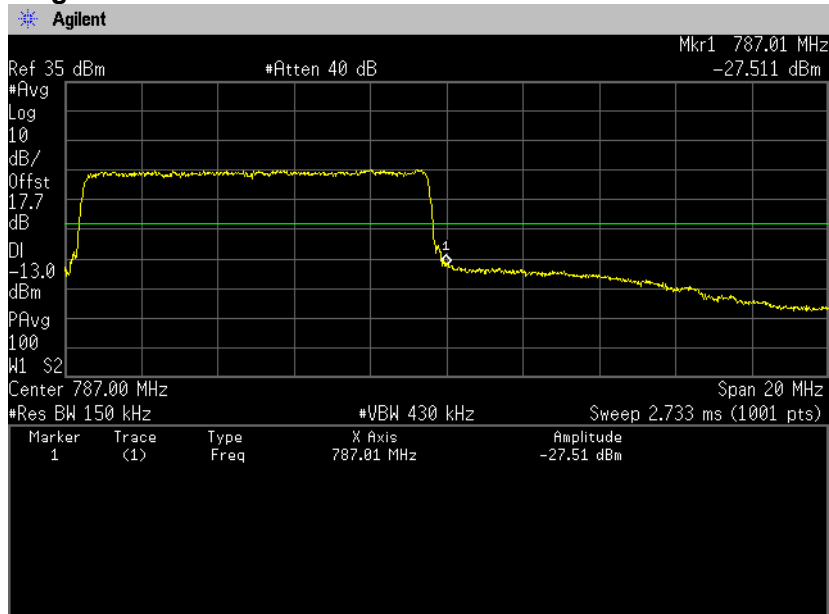



Zacta

(Spurious Emissions)
QPSK, BW 5MHz, RB1-0
Channel: 23205
30MHz-5GHz

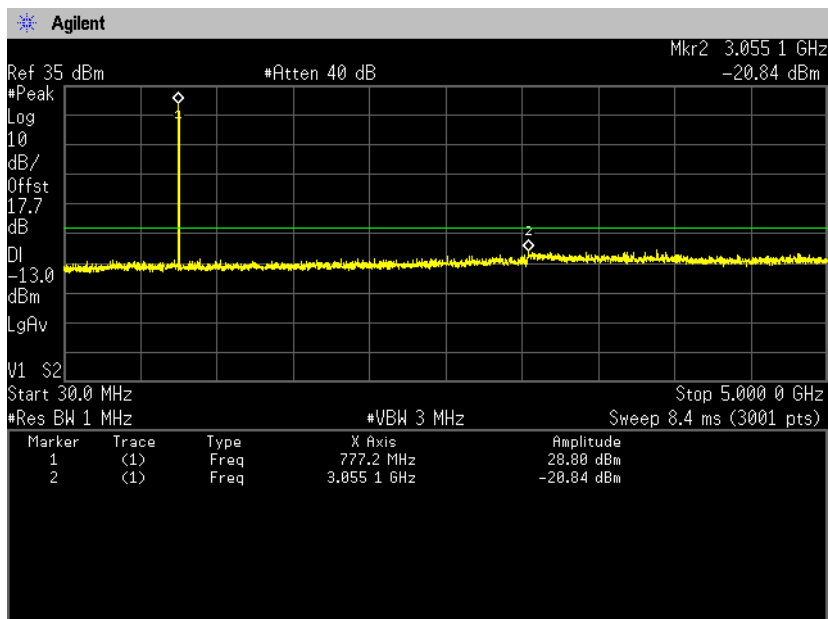

5GHz-10GHz

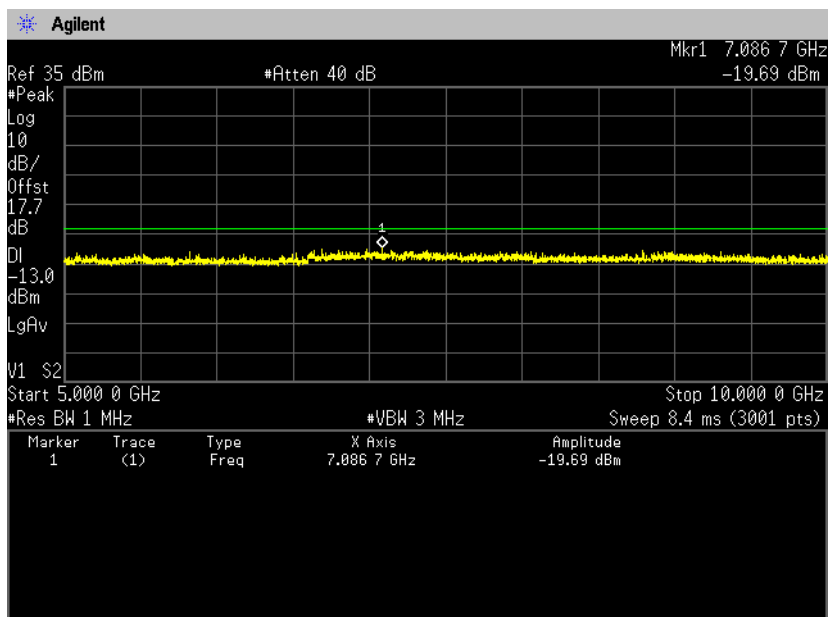



Zacta

**Channel: 23230
30MHz-5GHz**

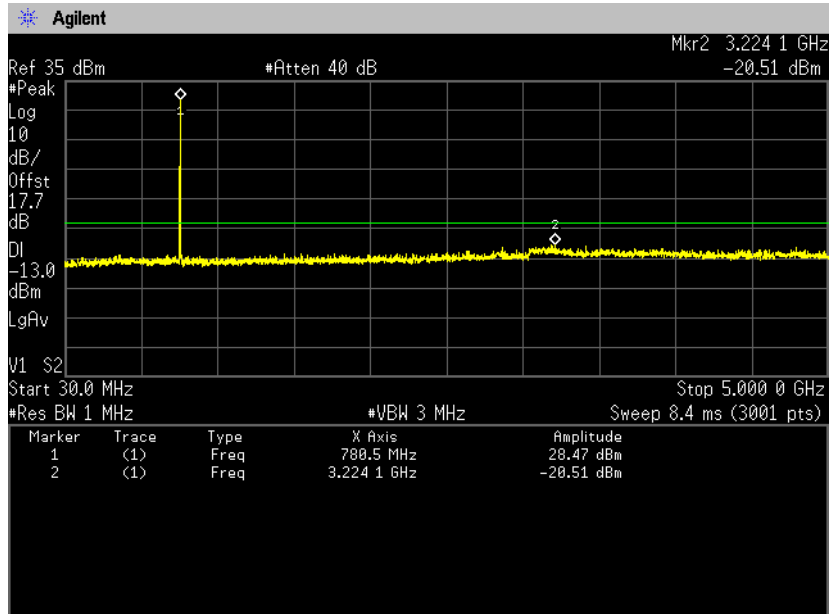

5GHz-10GHz

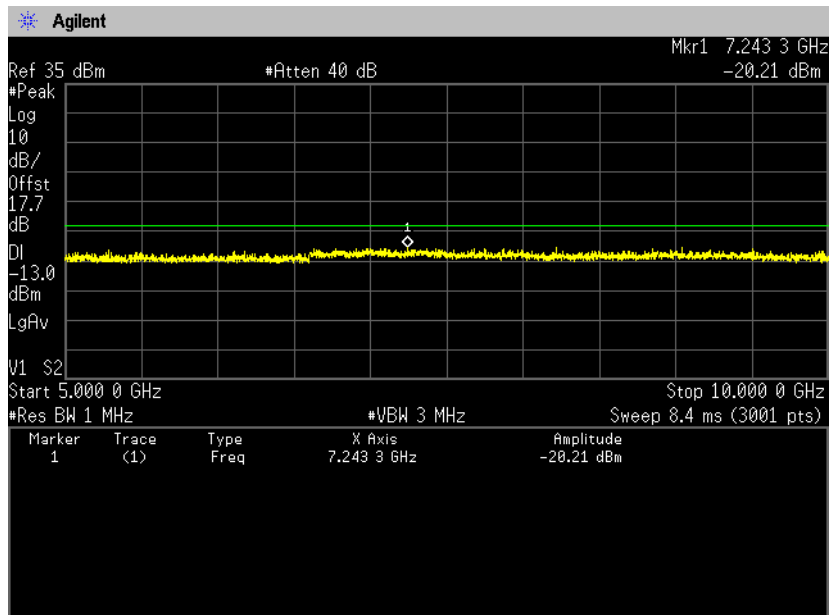



Zacta

**Channel: 23255
30MHz-5GHz**

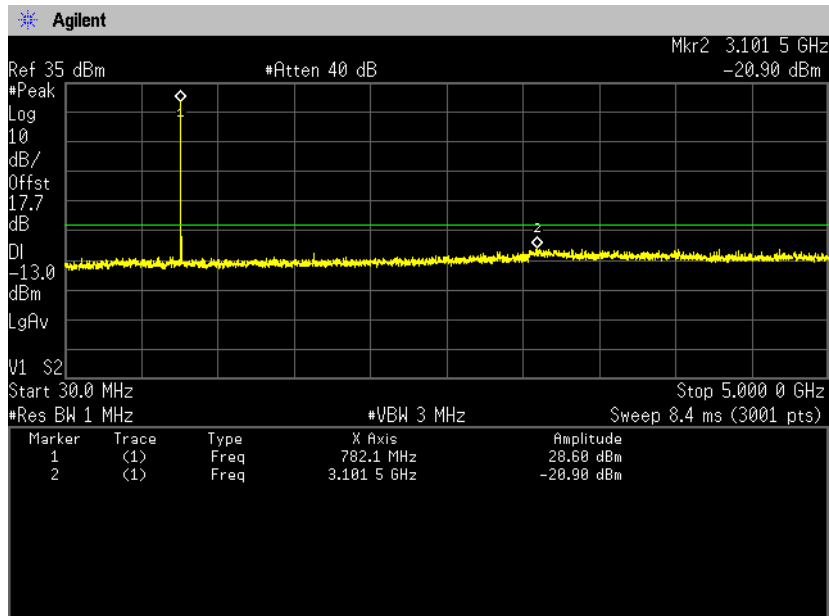

5GHz-10GHz

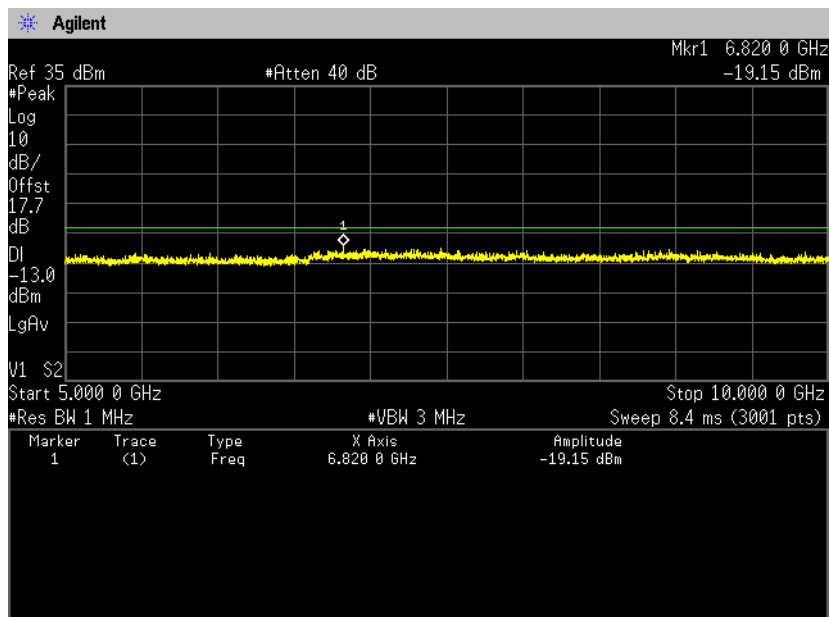



Zacta

16QAM, BW 10MHz, RB1-12
Channel: 23205
30MHz-5GHz

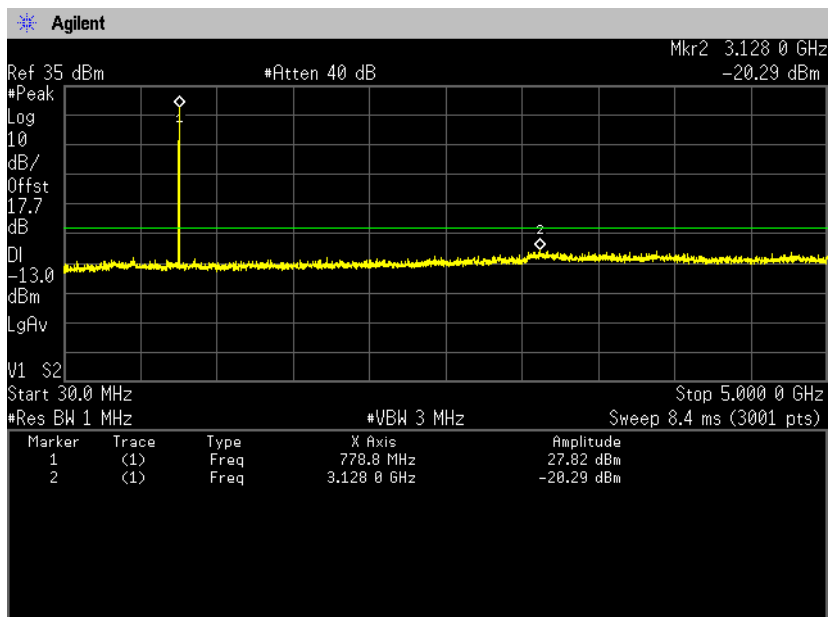

5GHz-10GHz

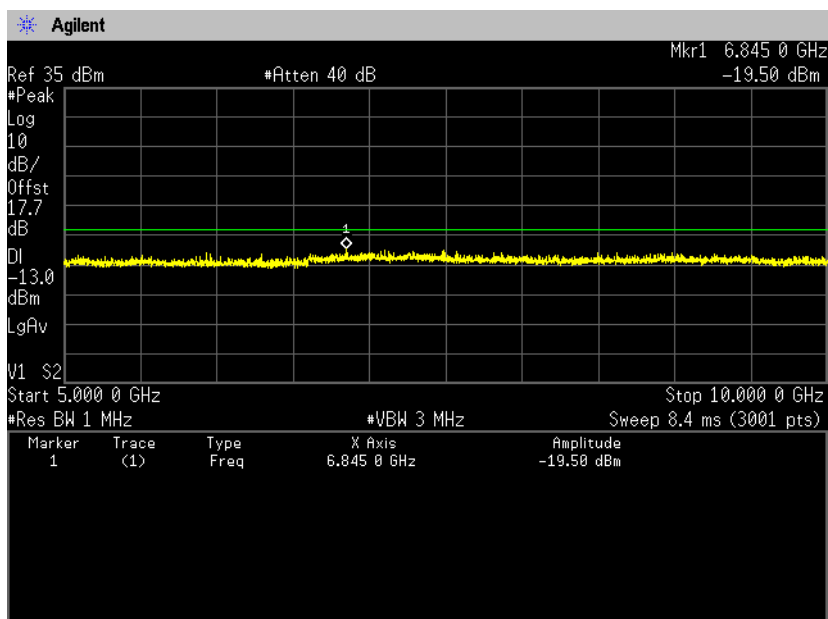



Zacta

**Channel: 23230
30MHz-5GHz**

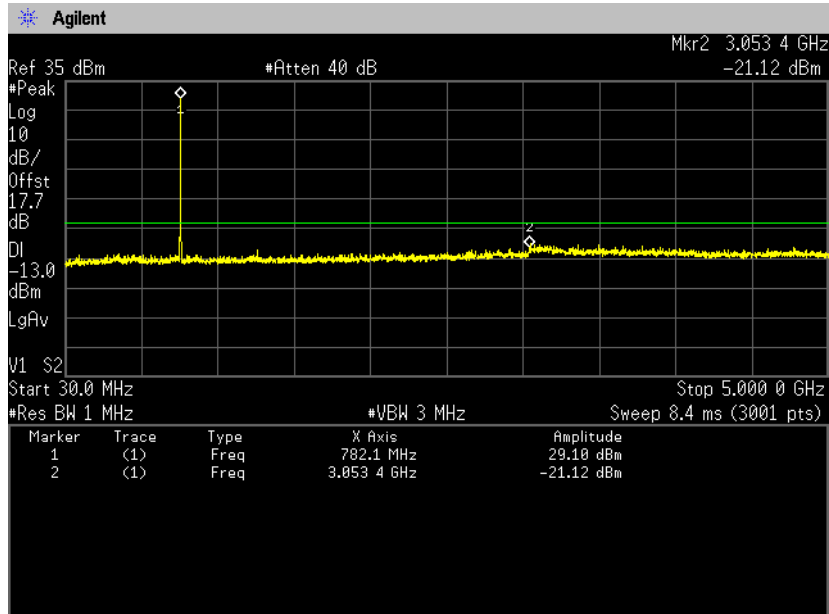

5GHz-10GHz

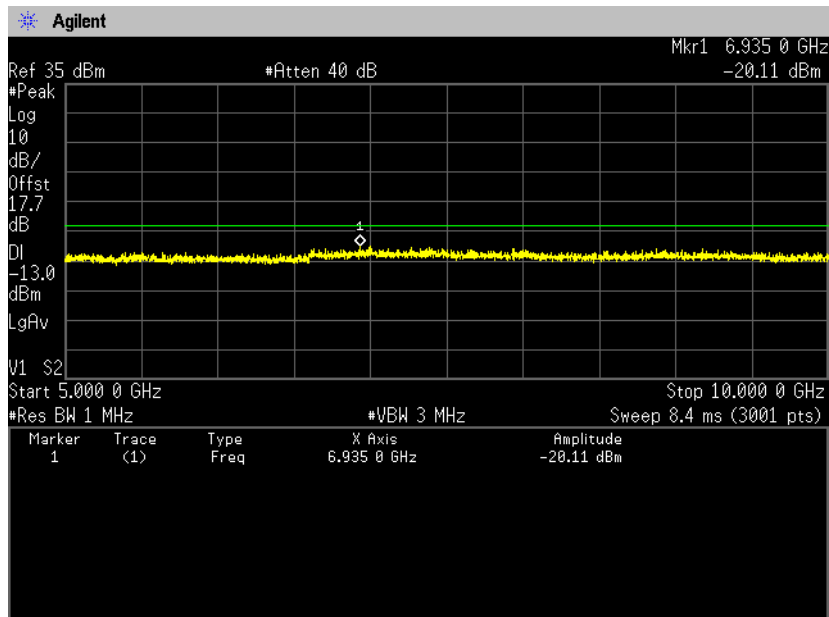



Zacta

**Channel: 23255
30MHz-5GHz**

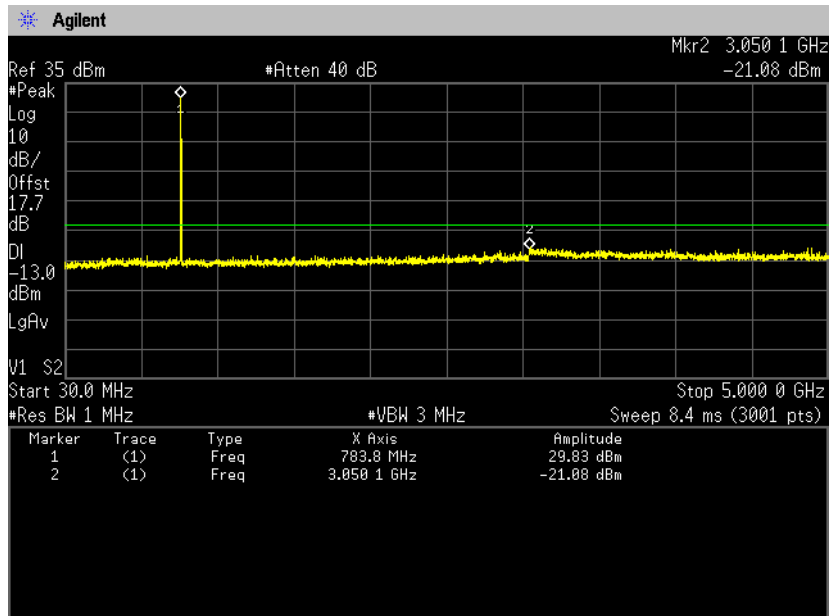

5GHz-10GHz

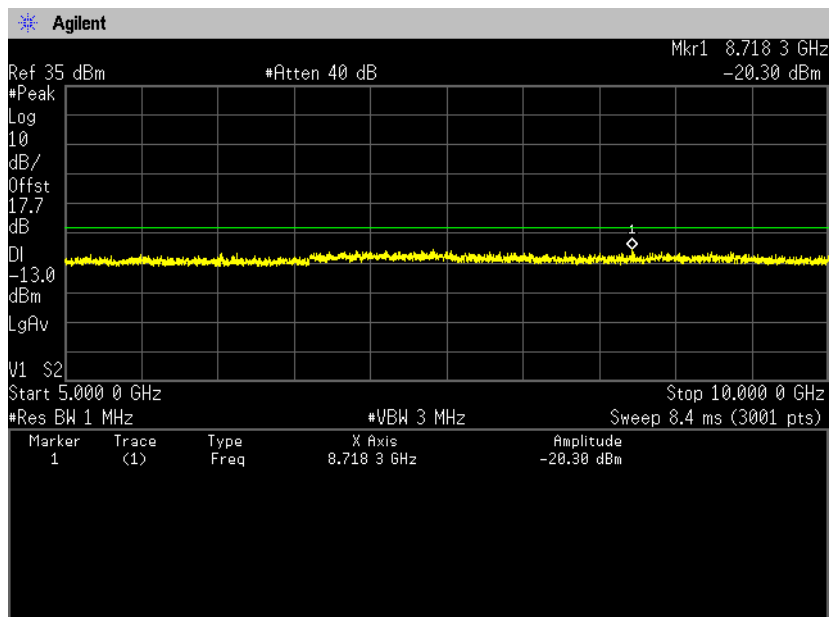

9. Radiated Emissions and Harmonic Emissions

9.1 Measurement procedure

[FCC 27.53(g), 2.1053, IC RSS-130 4.6]

<Step 1>

The EUT and support equipment are placed on a 1 meter x 1.5 meter surface, 0.8 meter height FRP table. Radiated emission measurements are performed at 3 meter distance with the broadband antenna (Biconical antenna, Log periodic antenna and double ridged guide antenna). The antenna is positioned both the horizontal and vertical planes of polarization and height is varied 1 to 4 meters and stopped at height producing the maximum emission.

The bandwidth of the spectrum analyzer is set to 1MHz. The turntable is rotated by 360 degrees and stopped at azimuth of producing the maximum emission. The frequency is investigated up to 20GHz.

<Step 2>

The substitution antenna is replaced by the transmitter antenna (EUT).

The frequency of the signal generator is adjusted to the measurement frequency.

Level of the signal generator is adjusted to the level that is obtained from step 1, and record the emission level of signal generator.

Spectrum analyzer setting

- Detector: Peak (RBW: 1MHz, VBW: 3MHz)

- Test configuration

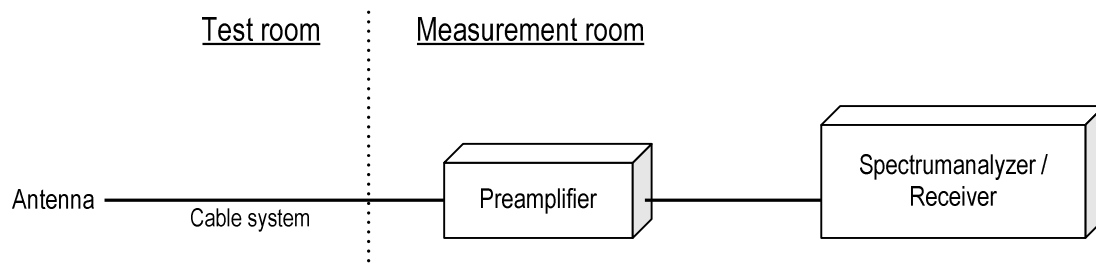

9.2 Calculation method

Result = S.G Reading – Cable loss + Antenna Gain

Margin = Limit – Result (ERP)

Example:

Limit @ 1554.7MHz : -13.0dBm

S.G Reading = -52.8dBm Cable loss = 1.0dB Ant. Gain = 6.4dBd

Result = -52.8 – 1.0 + 6.4 = -47.4dBm

Margin = -13.0 - (-47.4) = 34.4dB

9.3 Limit

-13dBm or less



Zacta

9.4 Test data

Date : June 24, 2015
 Temperature : 24.7 [°C]
 Humidity : 48.4 [%]
 Test place : 3m Semi-anechoic chamber
 Test engineer : Taiki Watanabe

Date : July 1, 2015
 Temperature : 23.7 [°C]
 Humidity : 58.2 [%]
 Test place : 3m Semi-anechoic chamber
 Test engineer : Hikaru Shibata

[LTE Band X III] QPSK, BW 5MHz Channel: 23205

H/V	Frequency [MHz]	S.A Reading [dBm]	S.G Reading [dBm]	Cable loss [dB]	Ant.Gain [dBd]	Result [dBm]	Limit [dBm]	Margin [dB]
H	1554.7	-50.3	-52.8	1.0	6.4	-47.4	-13.0	34.4
V	1554.7	-54.2	-59.5	1.0	6.4	-54.1	-13.0	41.1
H	2332.2	-60.5	-64.2	1.3	7.2	-58.3	-13.0	45.3
V	2332.0	-60.3	-60.6	1.3	7.2	-54.7	-13.0	41.7
H	3109.5	-57.8	-58.0	1.5	7.3	-52.2	-13.0	39.2
V	3109.5	-56.4	-54.1	1.5	7.3	-48.3	-13.0	35.3
H	3886.8	-60.2	-58.8	1.6	7.1	-53.3	-13.0	40.3
V	3886.8	-56.9	-54.1	1.6	7.1	-48.6	-13.0	35.6

Channel: 23230

H/V	Frequency [MHz]	S.A Reading [dBm]	S.G Reading [dBm]	Cable loss [dB]	Ant.Gain [dBd]	Result [dBm]	Limit [dBm]	Margin [dB]
H	1559.7	-46.0	-48.2	1.0	6.4	-42.8	-13.0	29.8
V	1559.7	-48.7	-52.7	1.0	6.4	-47.3	-13.0	34.3
H	2339.6	-61.5	-64.8	1.3	7.1	-58.9	-13.0	45.9
V	2339.6	-60.9	-60.9	1.3	7.1	-55.0	-13.0	42.0
H	3119.4	-61.0	-60.8	1.5	7.2	-55.0	-13.0	42.0
V	3119.4	-57.3	-54.6	1.5	7.2	-48.8	-13.0	35.8
H	3899.2	-60.8	-59.6	1.6	7.2	-54.1	-13.0	41.1
V	3899.2	-59.6	-57.5	1.6	7.2	-52.0	-13.0	39.0

Channel: 23255

H/V	Frequency [MHz]	S.A Reading [dBm]	S.G Reading [dBm]	Cable loss [dB]	Ant.Gain [dBd]	Result [dBm]	Limit [dBm]	Margin [dB]
H	1564.7	-51.1	-54.6	1.0	6.4	-49.2	-13.0	36.2
V	1564.7	-51.3	-55.7	1.0	6.4	-50.3	-13.0	37.3
H	2347.0	-59.4	-63.1	1.3	7.1	-57.2	-13.0	44.2
V	2347.0	-58.6	-58.8	1.3	7.1	-52.9	-13.0	39.9
H	3129.5	-60.1	-60.1	1.5	7.2	-54.3	-13.0	41.3
V	3129.5	-54.6	-51.6	1.5	7.2	-45.8	-13.0	32.8
H	3911.7	-62.0	-60.3	1.6	7.2	-54.7	-13.0	41.7
V	3911.7	-60.5	-59.0	1.6	7.2	-53.4	-13.0	40.4

16QAM, BW 5MHz**Channel: 23205**

H/V	Frequency [MHz]	S.A Reading [dBm]	S.G Reading [dBm]	Cable loss [dB]	Ant.Gain [dBd]	Result [dBm]	Limit [dBm]	Margin [dB]
H	1563.3	-50.9	-54.6	1.0	6.4	-49.2	-13.0	36.2
V	1563.3	-50.9	-57.0	1.0	6.4	-51.6	-13.0	38.6
H	2345.0	-60.5	-62.4	1.3	7.1	-56.5	-13.0	43.5
V	2345.0	-58.6	-59.6	1.3	7.1	-53.7	-13.0	40.7
H	3126.6	-59.8	-59.2	1.5	7.2	-53.4	-13.0	40.4
V	3126.6	-55.9	-53.8	1.5	7.2	-48.0	-13.0	35.0
H	3908.3	-59.9	-58.0	1.6	7.2	-52.4	-13.0	39.4
V	3908.3	-61.7	-61.0	1.6	7.2	-55.4	-13.0	42.4

Channel: 23230

H/V	Frequency [MHz]	S.A Reading [dBm]	S.G Reading [dBm]	Cable loss [dB]	Ant.Gain [dBd]	Result [dBm]	Limit [dBm]	Margin [dB]
H	1568.4	-49.8	-53.4	1.0	6.4	-48.0	-13.0	35.0
V	1568.4	-51.8	-58.2	1.0	6.4	-52.8	-13.0	39.8
H	2352.5	-58.7	-61.1	1.3	7.1	-55.2	-13.0	42.2
V	2352.5	-58.0	-58.6	1.3	7.1	-52.7	-13.0	39.7
H	3136.7	-58.9	-59.2	1.5	7.2	-53.5	-13.0	40.5
V	3136.7	-53.2	-51.5	1.5	7.2	-45.8	-13.0	32.8
H	3920.9	-57.4	-54.3	1.6	7.3	-48.7	-13.0	35.7
V	3920.9	-59.2	-58.5	1.6	7.3	-52.9	-13.0	39.9

Channel: 23255

H/V	Frequency [MHz]	S.A Reading [dBm]	S.G Reading [dBm]	Cable loss [dB]	Ant.Gain [dBd]	Result [dBm]	Limit [dBm]	Margin [dB]
H	1573.3	-51.0	-54.6	1.0	6.5	-49.2	-13.0	36.2
V	1573.3	-55.8	-61.9	1.0	6.5	-56.5	-13.0	43.5
H	2360.0	-59.6	-62.0	1.3	7.2	-56.1	-13.0	43.1
V	2360.0	-61.4	-62.3	1.3	7.2	-56.4	-13.0	43.4
H	3146.7	-58.2	-58.0	1.5	7.2	-52.3	-13.0	39.3
V	3146.7	-58.1	-56.3	1.5	7.2	-50.6	-13.0	37.6
H	3933.3	-60.4	-58.8	1.6	7.3	-53.2	-13.0	40.2
V	3933.3	-57.7	-56.7	1.6	7.3	-51.0	-13.0	38.0

QPSK, BW 10MHz**Channel: 23230**

H/V	Frequency [MHz]	S.A Reading [dBm]	S.G Reading [dBm]	Cable loss [dB]	Ant.Gain [dBd]	Result [dBm]	Limit [dBm]	Margin [dB]
H	1572.9	-52.9	-56.5	1.0	6.5	-51.1	-13.0	38.1
V	1572.9	-52.2	-58.3	1.0	6.5	-52.9	-13.0	39.9
H	2359.2	-60.7	-63.1	1.3	7.2	-57.2	-13.0	44.2
V	2359.2	-61.0	-61.9	1.3	7.2	-56.0	-13.0	43.0
H	3145.7	-58.7	-58.5	1.5	7.2	-52.8	-13.0	39.8
V	3145.7	-57.1	-55.3	1.5	7.2	-49.6	-13.0	36.6
H	3932.1	-56.1	-54.5	1.6	7.3	-48.8	-13.0	35.8
V	3932.1	-58.1	-57.1	1.6	7.3	-51.4	-13.0	38.4

16QAM, BW 10MHz**Channel: 23230**

H/V	Frequency [MHz]	S.A Reading [dBm]	S.G Reading [dBm]	Cable loss [dB]	Ant.Gain [dBd]	Result [dBm]	Limit [dBm]	Margin [dB]
H	1572.9	-51.5	-54.6	1.0	6.5	-49.2	-13.0	36.2
V	1572.9	-51.4	-61.9	1.0	6.5	-56.5	-13.0	43.5
H	2359.2	-60.4	-62.0	1.3	7.2	-56.1	-13.0	43.1
V	2359.2	-61.1	-62.3	1.3	7.2	-56.4	-13.0	43.4
H	3145.7	-59.2	-58.0	1.5	7.2	-52.3	-13.0	39.3
V	3145.7	-54.9	-56.3	1.5	7.2	-50.6	-13.0	37.6
H	3932.1	-57.0	-58.8	1.6	7.3	-53.1	-13.0	40.1
V	3932.1	-58.0	-56.7	1.6	7.3	-51.0	-13.0	38.0

10. Frequency Stability

10.1 Measurement procedure

[FCC 27.54, 2.1055, IC RSS-130 4.3]

The EUT was placed inside of a constant temperature chamber as the temperature in the chamber was varied between -30°C and $+50^{\circ}\text{C}$. The temperature was incremented by 10°C intervals and the unit was allowed to stabilize at each measurement. The frequency drift was measured with the normal Temperature and voltage tolerance and it is presented as the ppm unit.

- Test configuration

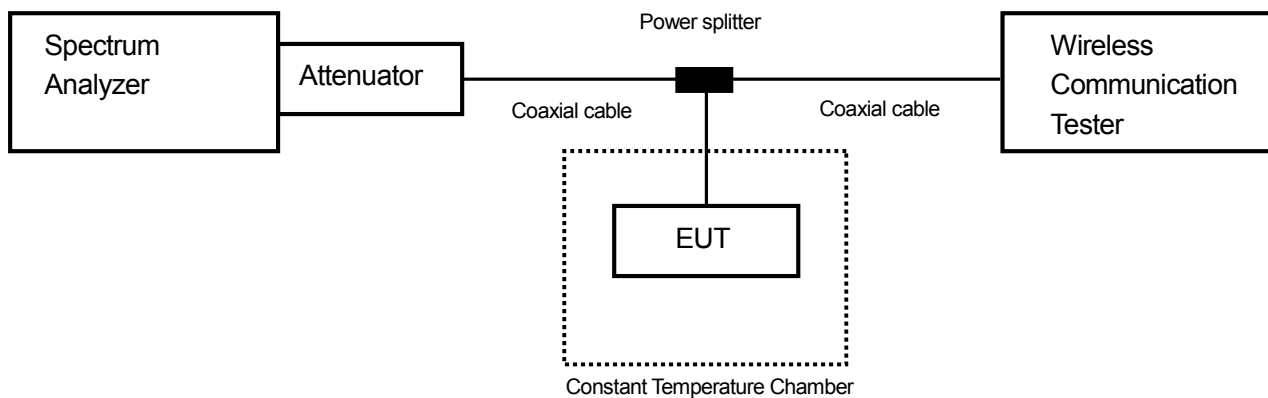

10.2 Limit

$\pm 2.5\text{ppm}$



Zacta

10.3 Measurement result

Date : June 25, 2015

Temperature : 24.7 [°C]

Humidity : 52.3 [%]

Test place : Shielded room No.4

Test engineer :

Hikaru Shibata

[LTE Band X III]

(Channel: 23230)

Limit: $\pm 0.00025\% = \pm 2.5\text{ppm}$					
Power Supply [V]	Temperature [°C]	Measurements Frequency [Hz]	Frequency Tolerance [ppm]	Limit [ppm]	Result
3.90	25(Ref.)	781,999,417	0.00000	± 2.5	Pass
	50	781,998,619	-1.02098	± 2.5	Pass
	40	782,000,378	1.22881	± 2.5	Pass
	30	781,999,283	-0.17154	± 2.5	Pass
	20	781,999,361	-0.07231	± 2.5	Pass
	10	781,998,675	-0.94936	± 2.5	Pass
	0	781,999,839	0.53885	± 2.5	Pass
	-10	781,998,406	-1.29335	± 2.5	Pass
	-20	781,999,299	-0.15118	± 2.5	Pass
	-30	782,000,192	0.99077	± 2.5	Pass
3.315	25	781,998,549	-1.11049	± 2.5	Pass
4.485	25	781,998,890	-0.67443	± 2.5	Pass

Calculation;

$$\text{Frequency Tolerance (ppm)} = \frac{\text{Measurements Frequency (Hz)} - \text{Reference Frequency (Hz)}}{\text{Reference Frequency (Hz)}} \times 1000000$$



Zacta

11. Uncertainty of measurement

Expanded uncertainties stated are calculated with a coverage Factor $k=2$.

Please note that these results are not taken into account when determining compliance or non-compliance with test result.

Test item	Measurement uncertainty
Conducted emission at mains port	$\pm 3.0\text{dB}$
Radiated emission (9kHz – 30MHz)	$\pm 4.4\text{dB}$
Radiated emission (30MHz – 1000MHz)	$\pm 4.5\text{dB}$
Radiated emission (1000MHz – 26GHz)	$\pm 3.9\text{dB}$



Zacta

12. Laboratory description

1. Location:

TÜV SÜD Zacta Ltd. Yonezawa Testing Center
 4149-7 Hachimanpara 5-chome Yonezawa-shi Yamagata 992-1128 Japan
 Phone: +81-238-28-2880 Fax: +81-238-28-2888

2. Facility filing information:

1) NVLAP accreditation: NVLAP Lab. code: 200306-0

2) VLAC accreditation: Lab. code: VLAC-013

Site name	Radiated emission	Conducted emission for mains port	Conducted emission for telecom port	Radiated emission (CMAD)	Expiry Date
3m Semi-anechoic chamber	VLAC-013	VLAC-013	VLAC-013	-	Jul. 3, 2017
10m Semi-anechoic chamber No.1				VLAC-013	
10m Semi-anechoic chamber No.2				VLAC-013	
Shielded room No.1	-	VLAC-013	-	-	

3) FCC filing:

Site name	Registration Number	Expiry Date
Site 3	91065	Oct. 1, 2017
3m Semi-anechoic chamber	540072	Feb. 20, 2017
10m Semi-anechoic chamber No.1		
10m Semi-anechoic chamber No.2		
Shielded room No.1		

4) Industry Canada Oats site filing:

Site name	Sites on file: Oats 3m/10m	Expiry Date
Site 3	4224A-3	Dec. 3, 2017
3m Semi-anechoic chamber	4224A-4	
10m Semi-anechoic chamber No.1	4224A-5	
10m Semi-anechoic chamber No.2	4224A-6	Jan. 15, 2017

5) VCCI site filing:

Site name	Radiated emission	Conducted emission for mains port	Conducted emission for telecom port	Expiry Date
Site 3	R-138	C-134	T-1222	Nov. 16, 2017
3m Semi-anechoic chamber	A-0166	A-0166	A-0166	Jul. 3, 2017
10m Semi-anechoic chamber No.1				
10m Semi-anechoic chamber No.2				
Shielded room No.1	-	A-0166	A-0166	

6) TÜV SÜD PS authorization:

Authorized as an EMC test laboratory

7) TÜV Rheinland authorization:

Authorized as an EMC test laboratory



Appendix A. Test equipment

Antenna port conducted test

Equipment	Company	Model No.	Serial No.	Cal. due	Cal. date
Spectrum analyzer	Agilent Technologies	E4440A	US44302655	Jun. 30, 2016	Jun. 11, 2015
Microwave cable	RS	YH20_S1	N/A (S389)	Aug. 31, 2015	Aug. 30, 2014
Attenuator	Weinschel	56-10	J4180	Nov. 30, 2015	Nov. 12, 2014
Microwave cable	SUHNER	SUCOFLEX104/1.5m	199121/4	Oct. 31, 2015	Oct. 7, 2014
Microwave cable	SUHNER	SUCOFLEX104/1.5m	322086/4	Jul. 31, 2015	Jul. 30, 2014
Power splitter	ANRITSU	K240B	020205	Jul. 31, 2015	Jul. 12, 2014
Wideband radio frequency tester	ROHDE&SCHWARZ	CMW500	116338	Apr. 30, 2016	Apr. 2, 2015
Operation type temperature controlled bath	Espec	PL1KP	14007261	Jan. 31, 2016	Jan. 9, 2015

Radiated emission

Equipment	Company	Model No.	Serial No.	Cal. Due	Cal. Date
EMI Receiver	ROHDE&SCHWARZ	ESCI	100451	Dec. 31, 2015	Dec. 25, 2014
Preamplifier	ANRITSU	MH648A	M96057	Jun. 30, 2016	Jun. 12, 2015
Biconical antenna	Schwarzbeck	VHA9103/BBA9106	2125	Jun. 30, 2016	Jun. 4, 2015
Log periodic antenna	Schwarzbeck	UHALP9108A	0560	Jun. 30, 2016	Jun. 4, 2015
Attenuator	TME	CFA-01NPJ-6	N/A (S275)	Jun. 30, 2016	Jun. 23, 2015
Attenuator	TME	CFA-01NPJ-3	N/A (S272)	Jun. 30, 2016	Jun. 23, 2015
Spectrum analyzer	Agilent Technologies	E4440A	US44302655	Jun. 30, 2016	Jun. 11, 2015
Preamplifier	TSJ	MLA-100M18-B02-40	1929118	May 31, 2016	May 1, 2015
Attenuator	AEROFLEX	26A-10	081217-08	Mar. 31, 2016	Mar. 12, 2015
Dipole antenna	Schwarzbeck	VHAP	1020	Sep. 30, 2015	Sep. 5, 2014
Dipole antenna	Schwarzbeck	UHAP	994	Sep. 30, 2015	Sep. 5, 2014
Double ridged guide antenna	EMCO	3115	5205	Feb. 29, 2016	Feb. 16, 2015
Attenuator	Agilent Technologies	8491B	MY39268633	Feb. 29, 2016	Feb. 1, 2015
Double ridged guide antenna	EMCO	3115	000058532	Oct. 31, 2015	Oct. 14, 2014
Signal generator	ROHDE&SCHWARZ	SMB100A	177525	Jun. 30, 2016	Jun. 19, 2015
Power amplifier	R&K	CGA020M602-2633R	B40240	Mar.31, 2016	Mar. 23, 2015
Microwave cable	SUHNER	SUCOFELX102/2m	31648/2	Mar. 28, 2016	Mar. 10, 2015
High pass filter	Micro-Tronics	HPM50115	004	Jul. 31, 2015	Jul. 12, 2014
High pass filter	Wainwright	WHKX2.8/18G-6SS	1	Jul. 31, 2015	Jul. 17, 2014
Wideband radio frequency tester	ROHDE&SCHWARZ	CMW500	126079	Aug. 31, 2015	Aug. 28, 2014
Microwave cable	SUHNER	SUCOFLEX104/9m	346316/4	Oct. 31, 2015	Oct. 31, 2014
		SUCOFLEX104/1m	322084/4	Oct. 31, 2015	Oct. 31, 2014
		SUCOFLEX104/1.5m	317226/4	Oct. 31, 2015	Oct. 31, 2014
		SUCOFLEX104/7m	41625/6	Oct. 31, 2015	Oct. 31, 2014
PC	DELL	DIMENSION E521	75465BX	N/A	N/A
Software	TOYO Corporation	EP5/RE-AJ	0611193/V5.3.61	N/A	N/A
3m Semi-anechoic chamber	TOKIN	N/A	N/A (9002-NSA)	Apr. 30, 2016	Apr. 27, 2015
3m Semi-anechoic chamber	TOKIN	N/A	N/A (9002-SVSWR)	Apr. 30, 2016	Apr. 27, 2015

*: The calibrations of the above equipment are traceable to NIST or equivalent standards of the reference organizations.