



# EMI TEST REPORT

Test Report No. : 26KE0199-HO-A

Applicant : KYOCERA Corporation  
Type of Equipment : iBurst User Terminal  
Model No. : UTU1900D-US-A  
Test standard : FCC Part 24 2005  
FCC ID : JOYIUU19AB  
Test Result : Complied

1. This test report shall not be reproduced in full or partial, without the written approval of UL Apex Co., Ltd.
2. The results in this report apply only to the sample tested.
3. This equipment is in compliance with the above regulation. We hereby certify that the data contain a true representation of the EMC profile.
4. The test results in this report are traceable to the national or international standards.

Date of test:

August 5 to 18, 2006

Tested by:

*K. Adachi*

Kenichi Adachi  
EMC Services

*M. Kosaka*

Makoto Kosaka  
EMC Services

Approved by :

*Naoki Sakamoto*

Naoki Sakamoto  
Group Leader of  
EMC Services



NVLAP LAB CODE: 200572-0

This laboratory is accredited by the NVLAP LAB CODE 200572-0, U.S.A. The tests reported herein have been performed in accordance with its terms of accreditation.  
\*As for the range of Accreditation in NVLAP, you may refer to the WEB address, <http://ulapex.jp/emc/nvlap.htm>

UL Apex Co., Ltd.

Head Office EMC Lab.

4383-326 Asama-cho, Ise-shi, Mie-ken 516-0021 JAPAN

Telephone : +81 596 24 8116

Facsimile : +81 596 24 8124

MF060b(14.06.06)

---

<b>CONTENTS</b>	<b>PAGE</b>
<b>SECTION 1: Client information.....</b>	<b>3</b>
<b>SECTION 2: Equipment under test (E.U.T.) .....</b>	<b>3</b>
<b>SECTION 3: Test specification, procedures &amp; results .....</b>	<b>4</b>
<b>SECTION 4: Operation of E.U.T. during testing.....</b>	<b>6</b>
<b>SECTION 5: Peak Output Power and Spurious Radiation and Band-Edge.....</b>	<b>7</b>
<b>SECTION 6: Bandwidth and Band-Edge (Conducted).....</b>	<b>8</b>
<b>SECTION 7: Spurious Emission (Conducted) .....</b>	<b>8</b>
<b>SECTION 8: Frequency Stability .....</b>	<b>8</b>
<b>APPENDIX 1: Photographs of test setup.....</b>	<b>9</b>
<b>Spurious Radiation .....</b>	<b>9</b>
<b>Worst Case Position (Horizontal:X-axis / Vertical:Y-axis) .....</b>	<b>10</b>
<b>Frequency Stability .....</b>	<b>11</b>
<b>APPENDIX 2: Data of EMI test .....</b>	<b>12</b>
<b>Peak Output Power (Conducted) .....</b>	<b>12</b>
<b>Peak Output Power (Radiated) .....</b>	<b>14</b>
<b>Emission Bandwidth and 99%Occupied Bandwidth .....</b>	<b>15</b>
<b>Band Edge(Conducted) .....</b>	<b>17</b>
<b>Band Edge (Radiated) .....</b>	<b>22</b>
<b>Spurious Emission (Conducted) .....</b>	<b>23</b>
<b>Spurious Radiation .....</b>	<b>27</b>
<b>Frequency Stability(Temperature/Voltage Variation).....</b>	<b>33</b>
<b>APPENDIX 3: Test instruments .....</b>	<b>34</b>

## **SECTION 1: Client information**

Company Name : KYOCERA Corporation  
Address : Yokohama Office  
2-1-1 Kagahara, Tsuzuki-ku, Yokohama-shi, Kanagawa 224-8502, Japan  
Telephone Number : +81-45-943-6189  
Facsimile Number : +81-45-943-6123  
Contact Person : Toshihiko Kawata

## **SECTION 2: Equipment under test (E.U.T.)**

### **2.1 Identification of E.U.T.**

Type of Equipment : iBurst User Terminal  
Model No. : UTU1900D-US-A  
Serial No. : 01  
Rating : AC 120V / 60Hz (Host PC's AC Adapter), DC 4.5-5.5V (EUT)  
Country of Manufacture : JAPAN  
Receipt Date of Sample : July 28, 2006  
Condition of EUT : Production model  
Modification of EUT : No modification by the test lab.

### **2.2 Product Description**

Model No.: UTU1900D-US-A (referred to as the EUT in this report) is iBurst User Terminal.

Equipment Type : Transceiver  
Frequency operation : 1900-1910MHz  
Type of modulation : BPSK,QPSK,8PSK,12QAM,16QAM  
Bandwidth : 500kHz  
Channel spacing : 625kHz  
Channel number : 16  
Antenna Type : Chip antenna  
Antenna connector Type : MMCX  
Antenna Gain : 0dBi  
Other Clock Frequency : 72MHz, 24MHz, 20MHz, 18MHz, 6MHz, 3MHz, 32.768kHz  
Temperature of operation : 0 deg. C. to + 40 deg. C.

---

**UL Apex Co., Ltd.**

**Head Office EMC Lab.**

4383-326 Asama-cho, Ise-shi, Mie-ken 516-0021 JAPAN

Telephone : +81 596 24 8116

Facsimile : +81 596 24 8124

MF060b(14.06.06)

### **SECTION 3: Test specification, procedures & results**

#### **3.1 Test Specification**

Test Specification : FCC Part 24 2005  
Title : FCC 47CFR Part 24  
Personal Communications Services

#### **3.2 Procedures and results**

<b>Item</b>	<b>Test Method</b>	<b>FCC Regulations</b>	<b>Remarks</b>	<b>Deviation</b>	<b>Worst margin</b>	<b>Results</b>
Peak Output Power	Section 2.1046	Section 24.232(b)	Conducted/ Radiated	N/A	9.1dB 1904.6875MHz, Horizontal	Complied
Emission Bandwidth, 99% Occupied Bandwidth	Section 2.1049	Section 24.238(b)	Conducted	N/A	-	Complied
Band-Edge	Section 2.1049	Section 24.238(b)	Conducted/ Radiated	N/A	[Conducted] 3.90dB 1900MHz QPSK+ [Radiated] 8.7dB 1900MHz Vertical	Complied
Spurious Emission	Section 2.1051	Section 24.238(a)	Conducted	N/A	-	Complied
Spurious Radiation	Section 2.1053	Section 24.238(a)	Radiated	N/A	14.5dB 5714.06MHz Horizontal	Complied
Frequency Stability (Temperature Variation)	Section 2.1055(a) (1) and (b)	Section 24.235	Conducted	N/A	-	Complied
Frequency Stability (Voltage Variation)	Section 2.1055(d)(1) and (2)	Section 24.235	Conducted	N/A	-	Complied

Note: UL Apex's EMI Work Procedures No. QPM05

\*These tests were also referred to TIA-603-B "Land Mobile FM or PM Communications Equipment Measurement and Performance Standards."

\*These tests were performed without any deviations from test procedure except for additions or exclusions.

**UL Apex Co., Ltd.**

**Head Office EMC Lab.**

4383-326 Asama-cho, Ise-shi, Mie-ken 516-0021 JAPAN

Telephone : +81 596 24 8116

Facsimile : +81 596 24 8124

MF060b(14.06.06)

### 3.3 Confirmation

UL Apex Co., Ltd. hereby confirms that E.U.T., in the configuration tested, complies with the specifications FCC Part 24: 2005.

### 3.4 Uncertainty

#### Antenna terminal measurements

The measurement uncertainty (with a 95% confidence level) for this test is  $\pm 3.0$ dB

The data listed in this report meets the limits unless the uncertainty is taken into consideration.

#### Radiated emissions

The measurement uncertainty (with a 95% confidence level) for this test is  $\pm 4.62$ dB(30-1000MHz) and  $\pm 5.06$ dB(Above 1GHz).

The data listed in this report meets the limits unless the uncertainty is taken into consideration.

### 3.5 Test Location

UL Apex Co., Ltd. Head Office EMC Lab. \*NVLAP Lab. code: 200572-0

4383-326 Asama-cho, Ise-shi, Mie-ken 516-0021 JAPAN

Telephone: +81 596 24 8116

Facsimile: +81 596 24 8124

	FCC Registration Number	IC Registration Number	Width x Depth x Height (m)	Size of reference ground plane (m) / horizontal conducting plane	Other rooms
No.1 semi-anechoic chamber	313583	IC4247A	19.2 x 11.2 x 7.7m	7.0 x 6.0m	Preparation room
No.2 semi-anechoic chamber	655103	IC4247A-2	7.5 x 5.8 x 5.2m	4.0 x 4.0m	-
No.3 semi-anechoic chamber	148738	IC4247A-3	12.0 x 8.5 x 5.9m	6.8 x 5.75m	
No.3 shielded room	-	-	4.0 x 6.0 x 2.7m	N/A	-
No.4 semi-anechoic chamber	134570	IC4247A-4	12.0 x 8.5 x 5.9m	6.8 x 5.75m	-
No.4 shielded room	-	-	4.0 x 6.0 x 2.7m	N/A	-
No.5 semi-anechoic chamber	-	-	6.0 x 6.0 x 3.9m	N/A	-
No.6 shielded room	-	-	4.0 x 4.5 x 2.7m	2.0 x 2.0 m	-
No.6 measurement room	-	-	4.75 x 5.4 x 3.0m	4.75 x 5.4 m	-
No.7 shielded room	-	-	4.7 x 7.5 x 2.7m	4.7 x 7.5m	-
No.8 measurement room	-	-	3.1 x 5.0 x 2.7m	N/A	-

\* Size of vertical conducting plane (for Conducted Emission test) : 2.0 x 2.0m for No.1, No.2, No.3 and No.4 semi-anechoic chambers and No.7 shielded room.

### 3.6 Test set up, Test instruments and Data of EMI

Refer to APPENDIX 1 to 3.

**UL Apex Co., Ltd.**

**Head Office EMC Lab.**

4383-326 Asama-cho, Ise-shi, Mie-ken 516-0021 JAPAN

Telephone : +81 596 24 8116

Facsimile : +81 596 24 8124

MF060b(14.06.06)

**SECTION 4: Operation of E.U.T. during testing**

**4.1 Operating Modes**

The EUT was operated in a manner similar to typical use during the tests.

The mode is used :       Transmitting mode  
Low Channel       :1900.3125MHz (Ch0)  
Mid Channel       :1904.6875MHz (Ch7)  
High channel       :1909.6875MHz (Ch15)

Justification: The system was configured in typical fashion (as a customer would normally use it) for testing.

**4.2 Configuration and peripherals**

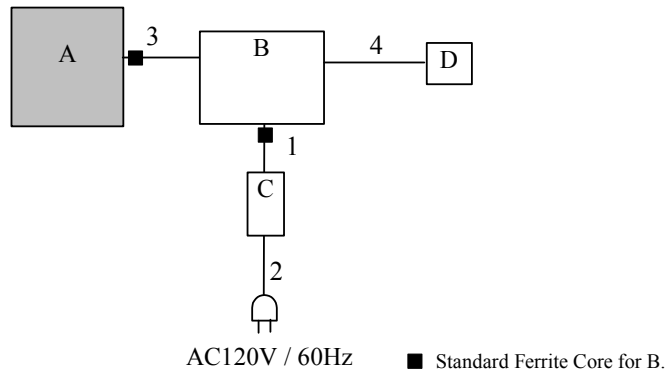

\* Cabling and setup were taken into consideration and test data was taken under worst case conditions.

**Description of EUT and Support equipment**

No.	Item	Model number	Serial number	Manufacturer	Remarks
A	iBurst User Terminal	UTU1900D-US-A	01	KYOCERA	EUT
B	PC	TYPE2662-LBJ	FX-FL781	IBM	-
C	AC Adapter for PC	AA21131	11S02K6657Z1Z 0ZA0651RX	IBM	-
D	Mouse	M-U48a	LNA12600205	Logitech	-

**List of cables used**

No.	Name	Length (m)	Shield		Remarks
			Cable	Connector	
1	DC Cable	1.8	Unshielded	Unshielded	-
2	AC Cable	1.0	Unshielded	Unshielded	-
3	USB Cable	1.0	Shielded	Shielded	-
4	Mouse Cable	1.9	Unshielded	Unshielded	-

## **SECTION 5: Peak Output Power and Spurious Radiation and Band-Edge**

[Conducted]

### **Test Procedure**

The peak output power (conducted) was measured with a spectrum analyzer and an attenuator at the antenna port.

**Test data** : **APPENDIX 3**  
**Test result** : **Pass**

[Radiated]

### **Test Procedure**

- 1) EUT was placed on a urethane platform of nominal size, 1.0m by 0.5m, raised 80cm above the conducting ground plane. Test was made with the antenna positioned in both the horizontal and vertical planes of polarization.  
The Radiated Electric Field Strength intensity has been measured in a semi anechoic chamber with a ground plane and at a distance of 3m.  
The measuring antenna height was varied between 1 to 4m and EUT was rotated a full revolution in order to obtain the maximum value of the electric field intensity.
- 2) Exchanged the EUT to the Substitution Antenna, the measurement was set for the same height 0.8m as the EUT. The frequency below 1GHz of the Substitution Antenna was used as the Half wave dipole Antenna, which is harmonized with the measured frequency in 1).  
The frequency above 1GHz of the Substitution Antenna was used with Horn Antenna.  
The Substitution Antenna was connected with the Signal Generator, and the polarized electromagnetic radiation of the Substitution Antenna was matched with the one of the measuring Antenna, which was set with the Signal Generator to the measured frequency in 1). Then, we set with the Output power (CW) of the Signal Generator where the measuring electromagnetic field is equal to the measured value in 1).  
The measuring antenna height varied between 1 and 4m to obtain the maximum receiving level.  
Its Output power of Signal Generator was recorded.
- 3) Equivalent isotropic radiated power was calculated by subtracting the cable loss and the attenuator loss connected between the Signal Generator and the Substitution Antenna from the Output power of the Signal Generator recorded in 2).

**Test data** : **APPENDIX 3**  
**Test result** : **Pass**

- The carrier level and noise levels were confirmed at each position of X, Y and Z axes of EUT to see the position of maximum noise, and the test was made at the position that has the maximum noise.

## **SECTION 6: Bandwidth and Band-Edge (Conducted)**

### **Test Procedure**

The Emission Bandwidth, 99% Occupied Bandwidth and Band-Edge was measured with a spectrum analyzer and attenuator connected to the antenna port.

Test data : APPENDIX 3  
Test result : Pass

## **SECTION 7: Spurious Emission (Conducted)**

### **Test Procedure**

The Spurious Emission was measured with a spectrum analyzer and attenuator connected to the antenna port.

Test data : APPENDIX 3  
Test result : Pass

## **SECTION 8: Frequency Stability**

### **Test Procedure**

The Frequency Stability was measured with a Vector Signal Analyzer (89441A (HP)) connected to the antenna port. The Frequency Drift was measured with the 10 deg. C. steps from -30 deg.C. to 50 deg.C., and it is presented as the ppm unit. The Frequency Drift was measured with the normal temperature(20 deg.C.) and Voltage tolerance (0 %, +15%, -15%), and it is presented as the ppm unit.

Test data : APPENDIX 3  
Test result : Pass

---

**UL Apex Co., Ltd.**

**Head Office EMC Lab.**

4383-326 Asama-cho, Ise-shi, Mie-ken 516-0021 JAPAN

Telephone : +81 596 24 8116

Facsimile : +81 596 24 8124

MF060b(14.06.06)